

# Altivar 61

User manual

Retain for future use

Water Solution Control Card

**VW3 A3 503**

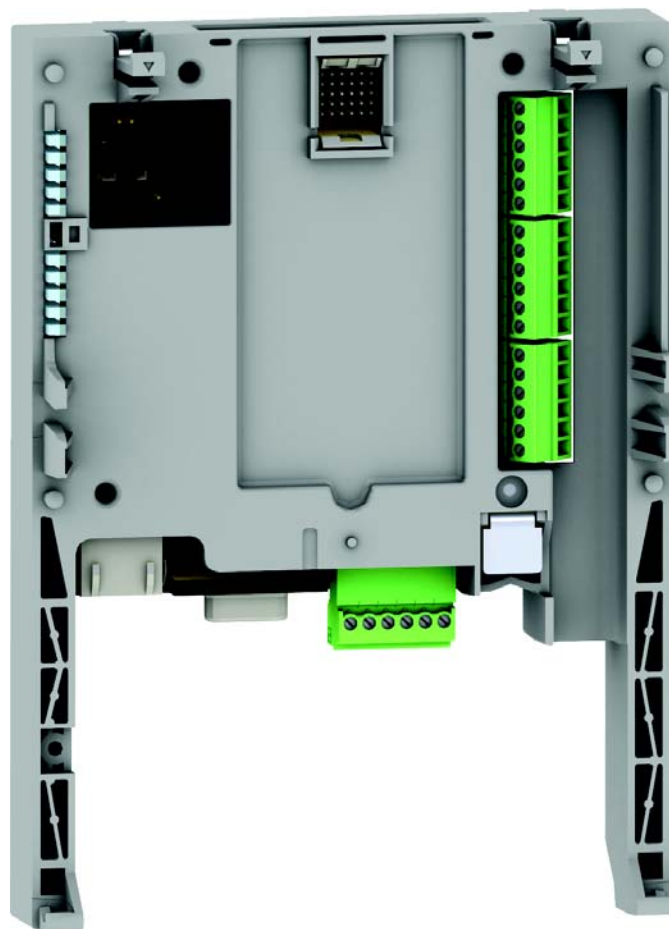



# Contents

---

Contents	3
Important Information	4
Before you Begin	5
Documentation Structure	6
Description	7
Hardware Setup	8
Introduction to Water Solution Program	11
Water Solution Program Features Overview	12
Water Solution Screen Navigation	19
Pre-configuration	21
Parameter Guide	22
Parameter Descriptions	23
Configuration Record	85

# Important Information

---

## NOTICE

Read these instructions carefully, and look at the equipment to become familiar with the device before trying to install, operate, or maintain it. The following special messages may appear throughout this documentation or on the equipment to warn of potential hazards or to call attention to information that clarifies or simplifies a procedure.



The addition of this symbol to a Danger or Warning safety label indicates that an electrical hazard exists, which will result in personal injury if the instructions are not followed.



This is the safety alert symbol. It is used to alert you to potential personal injury hazards. Obey all safety messages that follow this symbol to avoid possible injury or death.

## DANGER

DANGER indicates an imminently hazardous situation, which, if not avoided, **will result** in death, serious injury, or equipment damage.

## WARNING

Warning indicates a potentially hazardous situation, which, if not avoided, **can result** in death, serious injury, or equipment damage.

## CAUTION

CAUTION indicates a potentially hazardous situation, which, if not avoided, **can result** in injury or equipment damage.

## PLEASE NOTE

Electrical equipment should be serviced only by qualified personnel. No responsibility is assumed by Schneider Electric for any consequences arising out of the use of this material. This document is not intended as an instruction manual for untrained persons. © 2006 Schneider Electric. All Rights Reserved.

# Before you Begin

---

Read and understand these instructions before performing any procedure on this drive.

## DANGER

### HAZARDOUS VOLTAGE

- Read and understand the Installation manual before installing or operating the Altivar 61 drive. Installation, adjustment, repair, and maintenance must be performed by qualified personnel.
- The user is responsible for compliance with all international and national electrical standards in force concerning protective grounding of all equipment.
- Many parts of this variable speed drive, including the printed circuit boards, operate at the line voltage.  
DO NOT TOUCH.  
Use only electrically insulated tools.
- DO NOT touch unshielded components or terminal strip screw connections with voltage present.
- DO NOT short across terminals PA and PC or across the DC bus capacitors.
- Install and close all the covers before applying power or starting and stopping the drive.
- Before servicing the variable speed drive
  - Disconnect all power
  - Place a "DO NOT TURN ON" label on the variable speed drive disconnect
  - Lock the disconnect in the open position
- Disconnect all power including external control power that may be present before servicing the drive.  
WAIT 15 MINUTES to allow the DC bus capacitors to discharge. Then follow the DC bus voltage measurement procedure given in the installation manual to verify that the DC voltage is less than 45 VDC. The drive LEDs are not accurate indicators of the absence of DC bus voltage.

**Failure to follow these instructions will result in death or serious injury.**

## CAUTION

### DAMAGED EQUIPMENT

Do not install or operate any drive that appears damaged.

**Failure to follow this instruction can result in equipment damage.**

# Documentation Structure

---

## Installation manual

This manual describes:

- Assembly
- How to connect the drive

## Programming manual

This manual describes:

- The functions
- The parameters
- How to use the drive display terminal (integrated display terminal and graphic display terminal)

## Communication parameters manual

This manual describes:

- The drive parameters with specific information (addresses, formats, etc) for use via a bus or communication network
- The operating modes specific to communication (state chart)
- The interaction between communication and local control

## Modbus, CANopen, Ethernet, Profibus, INTERBUS, Uni-Telway, DeviceNet, Modbus Plus, FIPIO...

These manuals describe:

- Connection to the bus or network
- Configuration of the communication-specific parameters via the integrated display terminal or the graphic display terminal
- Diagnostics
- Software setup
- The communication services specific to the protocol

## Altivar 38 compatibility manual

This manual describes the differences between the Altivar 61 and the Altivar 38.

It explains how to replace an Altivar 38, including how to replace drives communicating on a bus or network.

# Description

---

## Parts Descriptions

Figure 1

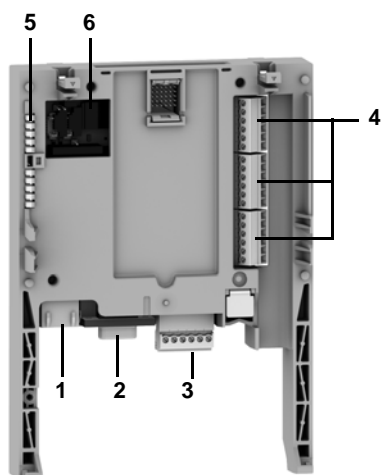

- 1** RJ45  
Connection to the PC is via a cable and an RS 232/RS 485 converter included in the PowerSuite for PC connection kit, VW3 A8 106.
- 2** Not used.
- 3** Connector with removable screw terminals, 6 contacts at intervals of 3.81 for the 24 V  $\equiv$  power supply and 4 logic inputs.
- 4** 3 connectors with removable screw terminals, 6 contacts at intervals of 3.81 for 6 logic inputs, 6 logic outputs, 2 analog inputs, 2 analog outputs and 2 commons.
- 5** 5 LEDs, comprising:
  - 1 to indicate the presence of the 24 V  $\equiv$  power supply
  - 1 to indicate a program execution fault
  - 2 not used
  - 1 controlled by the application program
- 6** Block of 4 configuration switches

# Hardware Setup

## Description of Terminals

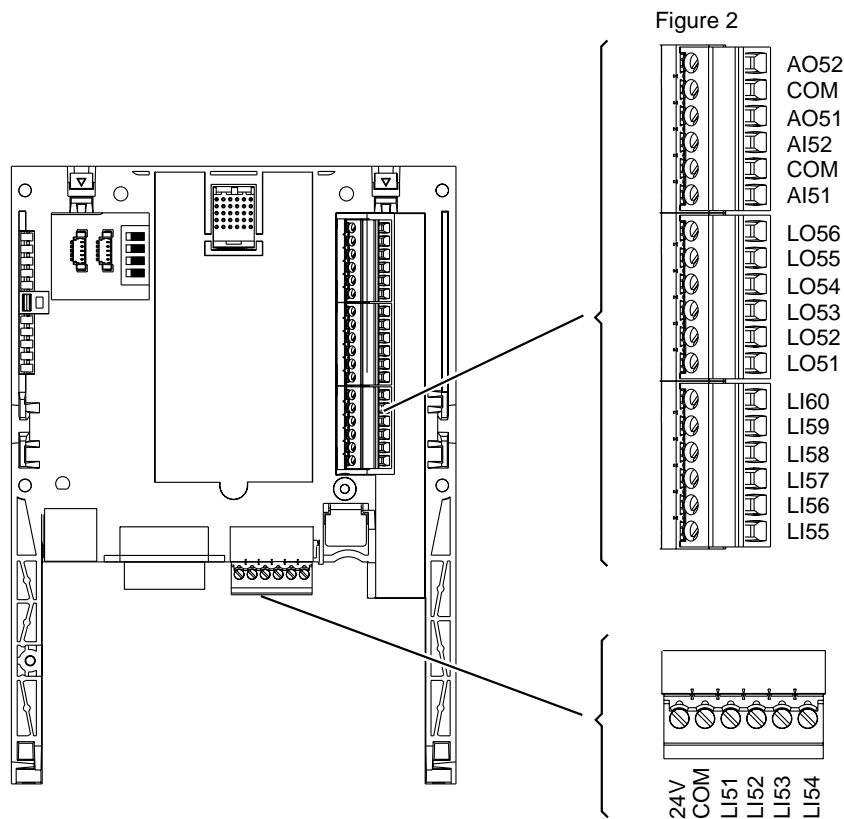

Terminal	Function
24 V	<p>Power supply for the "Water Solution" card, logic outputs and analog outputs.</p> <p>If allowed by the power consumption table (for example if outputs are not being used), the "Water Solution" card can be powered by the 24 V <math>\text{---}</math> power supply in the drive.</p> <p>If you are using an external power supply:</p> <ul style="list-style-type: none"> <li>The "Water Solution" card should preferably be turned on before the drive. However, the "Water Solution" card must without fail be turned on no more than 2 s after the drive is turned on. Failure to follow this instruction locks the drive in card fault mode (ILF). This fault cannot be reset, and the only way to acknowledge it is to turn off the drive.</li> <li>Catalog number for a Telemecanique power supply (24 V <math>\text{---}</math>, 2 A): ABL7 RE 24 02.</li> </ul>
COM	<p>Common ground and electrical 0V of the "Water Solution" card power supply, logic inputs, (LI●●), outputs (LO●●), analog inputs (AI●●) and analog outputs (AO●●).</p> <p>This ground and electrical 0 V are common with the drive ground and electrical 0 V. There is therefore no point in connecting this terminal to the 0 V terminal on the drive control terminals.</p>
LI51 to LI60	24 V $\text{---}$ logic inputs
LO51 to LO56	24 V $\text{---}$ logic outputs
AI51 and AI52	0 ... 20 mA analog inputs
AO51 and AO52	0 ... 20 mA analog outputs

# Hardware Setup

## Characteristics

### Electrical Characteristics

Power	Voltage	<b>V</b>	24 --- (min. 19, max. 30)
Current consumption	Maximum	<b>A</b>	2
	No-load	<b>mA</b>	80
	Using logic output	<b>mA</b>	200 maximum (1)
Analog inputs (1)	AI51, AI52		2 current analog inputs 0...20 mA, impedance 250 Ω Resolution: 10 bits Accuracy: ± 1 % for a temperature variation of 60 °C Linearity: ± 0.2 % of the maximum value Common point for all the card I/O (2)
Analog outputs	AO51, AO52		2 current analog outputs 0...20 mA, impedance 500 Ω Resolution: 10 bits Accuracy: ± 1 % for a temperature variation of 60 °C Linearity: ± 0.2 % of the maximum value Common point for all the card I/O (2)
Logic inputs (2)	LI51...LI60		10 logic inputs, 2 of which can be used for 2 counters or 4 of which can be used for 2 incremental encoders Impedance 4.4 kΩ Maximum voltage: 30 V --- Switching thresholds: State 0 if ≤ 5 V or logic input not wired State 1 if ≥ 11 V Common point for all the card I/O (2)
Logic outputs	LO51...LO56		Six 24 V --- logic outputs, positive logic open collector type (source), compatible with level 1 PLC, standard IEC 65A-68 Maximum switching voltage: 30 V Maximum current: 200 mA Common point for all the card I/O (2)
I/O connection	Type of contact		Screw, at intervals of 3.81 mm <sup>2</sup>
	Maximum wire	<b>mm<sup>2</sup></b>	1.5 (AWG 16)
	Tightening torque	<b>Nm</b>	0.25
Lithium battery	Life		8 years approx.

(1) If the power consumption table does not exceed 200 mA, this card can be powered by the drive. Otherwise, an external 24 V --- power supply must be used.

(2) This common point is also the drive 0 V (COM).

Note: When the VW3 A3 503 Water Solution Card is installed, the analogue inputs may be configured for 4-20 mA in screens [\[<EXPANSION>\] ~ \[CONFIG\] ~ \[CI\\_AI51 Type\]](#) and [\[<EXPANSION>\] ~ \[CONFIG\] ~ \[CI\\_AI52 Type\]](#). Please [See "\[1.14 - WATER SOLUT.\] ~ \[<EXPANSION>\] ~ \[CONFIG\] ~", page 83.](#)

## Data Backup Battery

The "Water Solution" card has a non-volatile RAM (NVRAM) which is needed to store variables. A lithium battery is mounted on this non-volatile RAM to avoid this data being lost when the card is turned off.

Figure 3

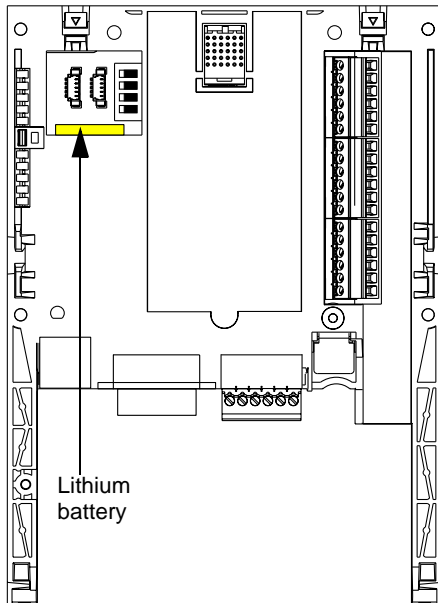

When installing the Water Solution card in the drive, make sure that this battery is present. It takes the form of a rectangular block clipped onto the non-volatile RAM (schematic opposite).

The battery life is approximately 8 years when turned off.

The battery has a realtime clock for timestamping faults.

The date and time on this clock are checked and set from a special sub-menu in the [\[1.14 - WATER SOLUT.\]](#) customizable menu in the graphic display terminal.

The date and time need to be set on receipt of the "Water Solution" card, or after replacing its lithium battery.

The lithium battery must only be replaced when the drive and the Water Solution card are turned off.

During this operation, the data saved in the NVRAM (4 Kwords) is lost.

 Save the configuration with PowerSuite v2.4 minimum before removing the battery.

# Introduction to Water Solution Program

This program provides a fully featured control algorithm for a constant pressure pumping system comprising of up to four pumps. The Variable speed pump is speed controlled from the Water Solution and the (up to) three additional external pumps can be DOL or preferably, under soft starter control. Provision also exists for a Jockey / Priming pump.

The Water Solution will determine how many External pumps need to be operating for the present demand and will operate the Variable speed pump at a variable speed to make up the demand requirement.

The control algorithm provides a PID function for the Variable speed pump reference. The pressure setpoint can either be entered into the Water Solution Display Unit, or can be sourced from one of the Analogue Inputs. The pressure feedback is connected to one of the Analogue Inputs.

Under normal operating conditions, the control algorithm will respond to an increase in demand by initially increasing the speed of the pump. If the pump is unable to fulfil the demand and has already reached full capacity, the control algorithm will switch in one of the External pumps. The Variable speed pump will then reduce in speed as it shares with the External pump to take up the demand.

The control algorithm will respond to a decrease in demand by initially decreasing the speed of the Variable speed pump. If the demand decreases further the control algorithm will switch out one of the External pumps. The Variable speed pump will then increase in speed to take up the demand.

The diagram below describes a typical variable pump system layout  
Figure 4

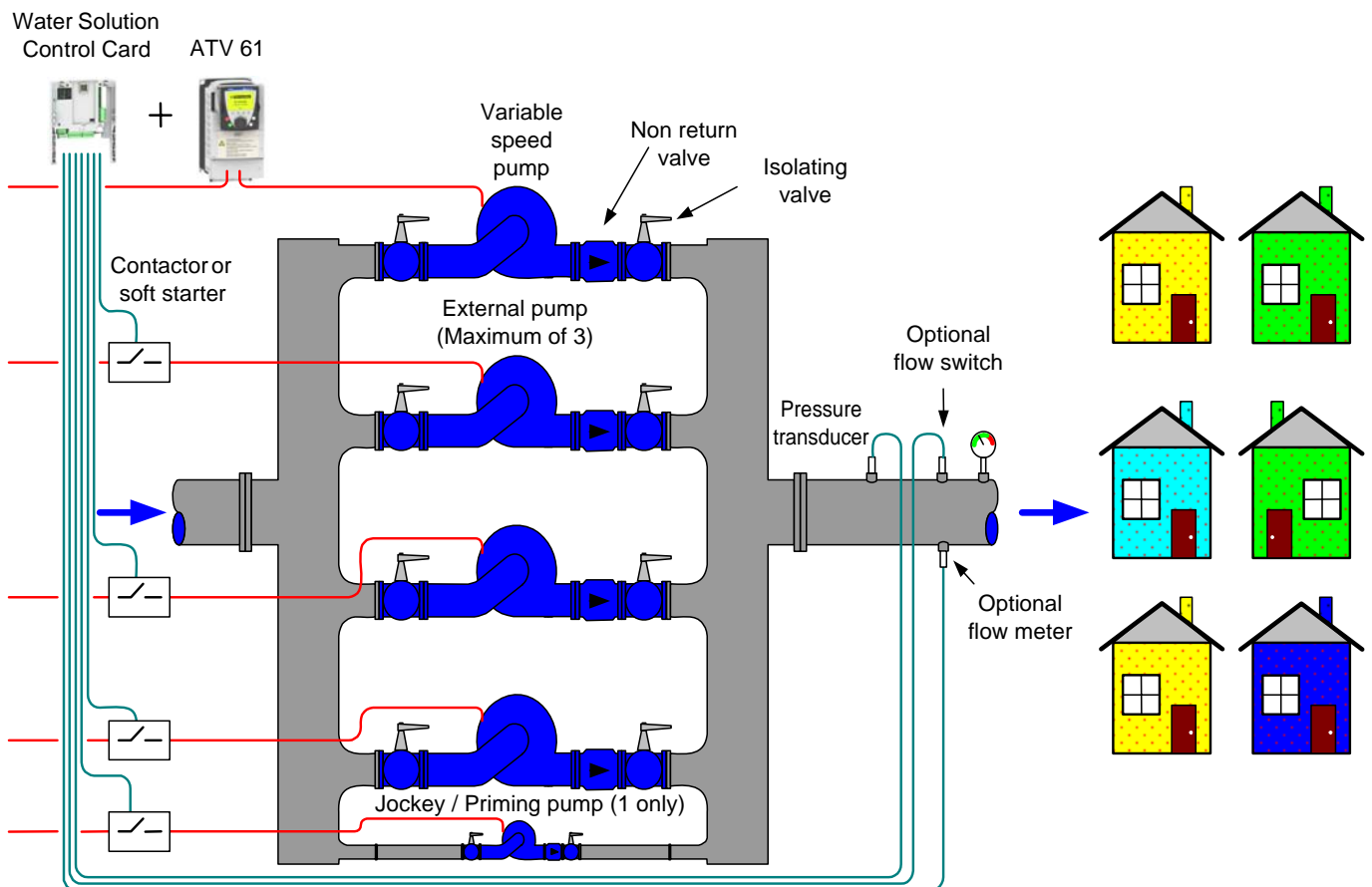

# Water Solution Program Features Overview

---

There are three modes of operation for the Water Solution Card:

- **Protected Manual Mode** is selected by closing digital input CI\_LI51. When in Protected Manual mode the Water Solution will run at the manual speed reference. All pump related protection algorithms are active and may stop the pump (eg High Pressure, Cycling, etc).
- **Override Manual Mode** is selected by closing digital input CI\_LI52. When in Override Manual mode the Water Solution will run at the manual speed reference, but no pump related control functions are active. It is the operator's responsibility to ensure the pump and installation are not operated outside of the normal operating conditions. Typically, the Override Manual function would be used to test motor rotation without the pump protection interfering. The status will display **[PRO MAN]** (Pmm) while in Protected Manual Mode and **[OVER MAN]** (Omm) while in Override Manual mode.
- **Pump Mode.**

The digital inputs for all three modes are mutually exclusive and only CI\_LI51 or CI\_LI52 or CI\_LI57 must be active at any time or the system will be disabled. When not in Manual mode, the Water Solution will be in Pump Mode when Digital Input CI\_LI57 is closed. When in Pump Mode, the Start and Stop commands and the speed reference are generated within the Water Solution control algorithm.

The following features are available in the Water Solution:

## Duty Sharing ([see page 51](#))

This pump control software is configured to provide control for up to three External pumps in a Variable speed pump control system for constant pressure pumping.

The control algorithm will respond to an increase in demand by initially increasing the speed of the Variable speed pump. If the Variable speed pump is unable to fulfil the demand and has already reached full capacity, the control algorithm will switch in one of the External pumps.

If Duty Sharing is disabled, under increasing demand conditions, the External pumps will be turned on in numerically increasing order. Under decreasing demand conditions, the External pumps will be turned off in numerically decreasing order. This means External pump 1 always turns on first and off last. However, an External pump that is faulted (via the digital input) will be skipped.

If Duty Sharing is enabled, then the External pumps will be selected based on their Run Time counters. Under increasing demand the External pumps will be selected in order of the lowest Run Time counters. Under decreasing demand, the External pumps are progressively switched off in order of the highest Run Time counters. This means the least used External pump always turns on first and turns off last. However, an External pump that is faulted (via the digital input) will be skipped.

## General Fault Segregation ([see page 37](#))

The Water Solution will respond to a fault condition in one of three ways, depending on the nature of the fault.

- 1 Drive or motor fault - This is a standard fault and the relevant drive manual should be consulted for further information. If a drive fault does occur however, the system will switch off all external pumps and ramp the Variable speed pump down before stopping.
- 2 Resettable System Fault - This is a pump system related fault that is expected to be cleared if the pump (system) shuts down temporarily. Depending on setup, a high pressure detected on the pressure feedback (analogue input) or a loss of feedback signal, a pump cavitation condition, or a Flow Switch activation while at high speed will all result in the pump tripping. A relevant fault message will be displayed and pushing key F1 (help) will result in further fault help messaging. If configured in this way the system will automatically reset a certain amount of times for each individual fault.
- 3 Non-Resettable System Fault - This is a pump system fault that is considered too serious to allow the pump to continue operating. Cycling of the pump (starting to often), activation of the Low Water digital input, or the minimum pressure detection will all result in the pump (system) tripping and remaining off until reset. A relevant fault message will be displayed and pushing key F1 (help) will result in further fault help messaging.

## External Pump Control - increasing demand ([staging](#))([see page 51](#))

The Variable speed pump will respond to an increase in demand by initially increasing speed. If the demand is too great for the Variable speed pump to fulfil, the Variable speed pump will start an External pump.

A high demand condition can be detected by either:

- High variable pump speed
- High variable pump speed + delay
- Increasing system error (system error = setpoint - feedback)
- Increasing system error + delay
- High variable pump speed and increasing system error
- High variable pump speed and increasing system error + delay

This allows the response mode to be setup to suit the system requirements.

# Water Solution Program Features Overview

---

## External Pump Control - decreasing demand (destaging) [\(see page 55\)](#)

The Variable speed pump will respond to a decrease in demand by initially decreasing speed. If the demand is too low for the number of pumps running, the Variable speed pump will stop an External pump.

A low demand condition can be detected by either:

- Low Variable pump speed
- Low Variable pump speed + delay
- Decreasing (or negative) system error (over pressure)
- Decreasing system error + delay
- Low Variable pump speed and decreasing system error
- Low Variable pump speed and decreasing system error + delay

This allows to set up the response mode to suit the system requirements.

In some cases, a decreasing demand condition may be required to turn the Variable speed pump off while one or more External Speed pumps are still running. Due to the flexibility of the Water Solution system, it is possible to configure the Variable speed pump to turn off due to the No Demand permissives while the External pumps continue to run.

## No Demand Shutdown

During a period of decreasing demand, the control algorithm will turn off the External pumps and the Variable speed pump will decrease. When a No Demand condition is detected, the Variable speed pump will automatically turn off and the pump system will remain in the state. A no demand condition can be detected by any combination of :

- Low Variable pump speed
- Low Variable speed pump current
- Low flow rate (flow meter)
- Low flow rate (flow switch)
- Advanced sleep detection

There is an adjustable delay after a No Demand condition has been detected, before the Variable speed pump automatically turns off and the pump system enters the state.

## PID Bypass Speeds [\(see page 52\)](#) and [page 56\)](#)

During pump switching, better performance may be achieved if the PID is bypassed, rather than relying on the PID response alone to adjust the Variable speed pump to accommodate for the increased or decreased flow capacity.

There are 2 bypass speeds available.

- 1 Stage Bypass - When the Water Solution requests an External pump to start, the Stage Bypass Speed is used to decrease the Variable speed pump to accommodate for the increased flow capacity of the additional pump.
- 2 Destage Bypass - When the Water Solution requests an External pump to stop, the Destage Bypass Speed is used to increase the Variable speed pump to accommodate for the decreased flow capacity.

The Water Solution's status will display **[BYP]** (BYP) while any of the Bypass speeds are active.

## Setpoint Ramp [\(see page 24\)](#)

On initial starting or after a period of no demand, the feedback pressure may be below the setpoint pressure. To avoid the effects of the resultant feedback error on the PID, the Setpoint Ramp algorithm overrides the pressure setpoint and applies a derived setpoint to the PID controller. The derived setpoint commences at the present feedback pressure (resulting in no error being applied to the PID controller) and ramps up to the desired setpoint. The rate at which the setpoint ramp occurs is adjustable.

The setpoint ramp is considered complete if the system error reduces to 0, (system error = setpoint - feedback) ie the system has successfully started and the feedback pressure has risen to the setpoint pressure.

The Water Solution's status screen will indicate **[SET RAMP]** (RAMP) during a Setpoint ramp.

## Pulse Flow Meter Input

The Water Solution will accept direct connection from a pulse emitter type flow meter. This pulse signal is directly converted into a flow rate within the Water Solution software.

The Water Solution will also accept a flow signal via the analogue inputs if required.

# Water Solution Program Features Overview

---

## Flow Limiting ([see page 45](#))

When the flow must be restricted to a particular level, the Flow Limit algorithm may be used. If the flow reaches the Flow Limit, the motor speed is ramped down. Once the flow is below the Flow Limit, the motor speed is held at its present value (or allowed to decrease if required). The Flow Limit algorithm will release the motor speed once the flow has dropped below the Flow Limit Reset. The rate at which the motor speed is ramped down is adjustable.

While the Flow Limit is active, the status will display **[Q LIMIT]** (QLT).

## Pipe Fill ([see page 23](#))

On initial start up, it is possible that there is minimal or no fluid in the downstream pipe. To avoid the effects of the resultant feedback error on the PID, the Pipe Fill algorithm may override the PID when the Variable speed pump starts. The Variable speed pump will run at a preset speed until the system pressure increases to indicate the presence of fluid in the pipe.

The "Water Solution's" status will display **[PIPE FILL]** (FILL) during while the Pipe Fill is active.

## Multiple Acceleration and Deceleration Rates

The system uses different rates depending status. One rate of acceleration and one of deceleration are able to be configured for times when the speed is below minimum (LSP). This is used to meet pump manufacturer specifications for pumps that require a minimum speed for pump cooling. There are also rates used when the system is under PID control which allows optimum performance. A third deceleration rate is used when the flow limit algorithm is active and a fourth when a fault condition is present.

## Automatic Turn-On Turn-Off (Set Time Pumping)

The pump system can be configured to run automatically based on time. The system can be allowed to start at a user specified time and also turn off at a user specified time. This allows for such things as night time irrigation.

## Pressure Display in Engineering Units

The pressure feedback signal can be displayed as a percentage value, or in the following engineering units:

- kPa
- bar
- psi

## Flow (friction loss) Compensation ([see page 67](#))

If a flow meter is installed, the flow compensation algorithm may be used to automatically adjust the setpoint pressure to compensate for losses due to the increasing flow. The friction loss that will occur may be determined empirically or the pressure drop measured at the outlet under a known flow condition.

The flow compensation algorithm uses this value to determine the compensation to be applied to the setpoint pressure at all flow rates.

This compensation algorithm is best suited for cold water piping systems, but will also generally provide acceptable compensation on most water systems.

Alternatively a fixed compensation may be utilised where a set amount of compensation is applied relative to the number of external pumps running and the dynamic speed of the Variable speed pump sets the proportion of Variable speed pump compensation.

## System Shutdown Options

The Variable speed pump stop type can be selected as either ramp stop or free wheel stop. If a fault condition is present and ramp stop is chosen the system will ramp down at the rate set as the fault ramp and then trip displaying the relevant fault message. If the fault is resettable the system may restart after a time delay if so configured.

When the Variable speed pump turns off under No Demand conditions, the destage mode selected will determine the response of the External pumps at this time. If the Variable speed pump is a condition of destaging, then the External pumps will sequentially shutdown at intervals of the destage delay. If the Variable speed pump is not a requirement for destaging, the External pumps will remain running until a decreasing demand causes an over-pressure condition.

# Water Solution Program Features Overview

---

## High Pressure Protection [\(see page 32\)](#)

There are two High Pressure protection mechanisms.

- 1 If enabled or auto reset is selected for high pressure then DRIVE\_LI3 is activated as a high pressure switch. This input accepts a normally closed input. If this input is then not active for 1 second the drive will trip. This fault will not auto reset.
- 2 If enabled or auto reset is selected for high pressure then the analogue pressure feedback signal can be used to protect for a high pressure condition. If a high pressure is detected and the digital protection level hasn't been exceeded (DRIVE\_LI3 is still present) the system will shut down (including all external pumps). If so configured the system will auto reset.

Note this will not protect against a high pressure condition if the feedback signal fails or goes open circuit.

## No Flow Protection [\(see page 32\)](#)

The system can be configured in many ways to protect against low flow. Digital protection can be used as well as or instead of a flow meter if one is installed. This protection can be set to operate during pipe fill or not. If low flow is detected the system will shut down and trip. If so configured the system will auto reset.

## Minimum Pressure (High Flow) Protection [\(see page 39\)](#)

If enabled the system will trip if a minimum pressure can't be met when the Variable speed pump is running at a speed greater than the one set. If minimum pressure (possible burst pipe) is sensed the system will stop and trip. This fault will not auto reset.

## Cavitation Protection [\(see page 32\)](#)

The Water Solution has a Cavitation protection algorithm. Cavitation is detected by high pump speed and low motor current. When cavitation is detected, the system will stop and trip displaying **[CAVITATION]**. If so configured the system will auto reset.

## Low Level Lockout (Low Water) Protection

If enabled the system will stop and trip if digital input CI\_LI60 is inactive for longer than a user adjustable time. This feature is typically used for low well level or low supply tank level.

During this period the status will display **[LOCK OUT]** (LOCK).

## Cycling Protection [\(see page 39\)](#)

The Cycle Protection is designed to protect against the condition where the system fails to maintain pressure in the **[READY]** state and the Variable speed pump immediately restarts (ie a faulty NRV). A start is considered to have occurred every time the pump accelerates from zero speed, and the Cycle counter is incremented on each start. If cycling is sensed, the system will stop and trip displaying **[CYCLING]**. This fault will not auto reset.

## Jockey Pump [\(see page 58\)](#)

During a period of no demand when the system has been in the **[SLEEP]** (SLP) state, a very low demand may cause the pump to cycle. The Jockey pump function is used to supply these very low demand requirements. Unless the pump is already running, the Jockey pump is turned on when the feedback pressure drops below the Jockey On Pressure. The Jockey pump will turn off if the feedback pressure increases above the Jockey Off Pressure or if the Variable speed pump starts.

The status will display **[JOCKEY ON]** (JKY) while the Jockey pump is on.

## Priming Pump

The Jockey relay can be configured for a priming pump. In this situation the relay will switch on whenever demand is present. The status will display **[JOCKEY ON]** (JKY) while the Jockey pump is on and the drive is off.

## Night and Day [\(see page 63\)](#)

This feature is used when no jockey pump is installed but instances of small demand are expected during the night. The feature uses the Variable speed pump at a fixed speed to meet small demands. This feature will automatically disable itself if a substantial demand is sensed via repeated starts in a short period of time or a lack of response in system pressure.

 Please note that the internal clock does not automatically switch to daylight saving time.

# Water Solution Program Features Overview

---

## **Inlet Protection** ([see page 71](#))

This feature requires a pressure transducer to be installed on the suction side of the Variable speed pump as well as one on the discharge. The applied setpoint is reduced when the suction pressure falls. This feature is typically used where the Variable speed pump is operating as a pressure booster.

## **Anti Jam** ([see page 74](#))

This feature is used to clear the pump impeller of any built-up product. This is done by cycling pump direction quickly. There are several means to trigger the **[Anti Jam]** function.

## **Frost Protection** ([see page 79](#))

This feature is used to protect crops susceptible to frost damage by either activating an alarm or by starting the system and using a custom PID setpoint, or both.

# System IO Configuration

---

The tables below describe the system IO configuration

## **Water Solution**

CI_LI51	Protected Manual Mode
CI_LI52	Override Manual Mode
CI_LI53	Low Flow Switch
CI_LI54	External Pump One No Fault
CI_LI55	External Speed Pump Two No Fault
CI_LI56	External Speed Pump Three No Fault
CI_LI57	Auto Enable
CI_LI58	Fault Reset
CI_LI59	Pulse Flow Switch
CI_LI60	Low Level Lockout

CI_LO51	External Speed Pump One Run
CI_LO52	External Speed Pump Two Run
CI_LO53	External Speed Pump Three Run
CI_LO54	System Run
CI_LO55	System Fault
CI_LO56	Jockey Pump / Priming Pump Run

CI_AI51	User assignable
CI_AI52	User assignable

CI_AO51	User assignable
CI_AO52	User assignable

## **ATV61**

DRIVE_LI1	Anti Jam Trigger
DRIVE_LI2	Alt Reference
DRIVE_LI3	High Pressure
DRIVE_LI4	Unused
DRIVE_LI5	Unused
DRIVE_LI6	Unused

DRIVE_LO1	Frost Alarm
DRIVE_LO2	Frost Activated

DRIVE_AI1	User assignable
DRIVE_AI2	User assignable

# Water Solution Electrical Schematic

Figure 5: Water Solution Electrical Schematic

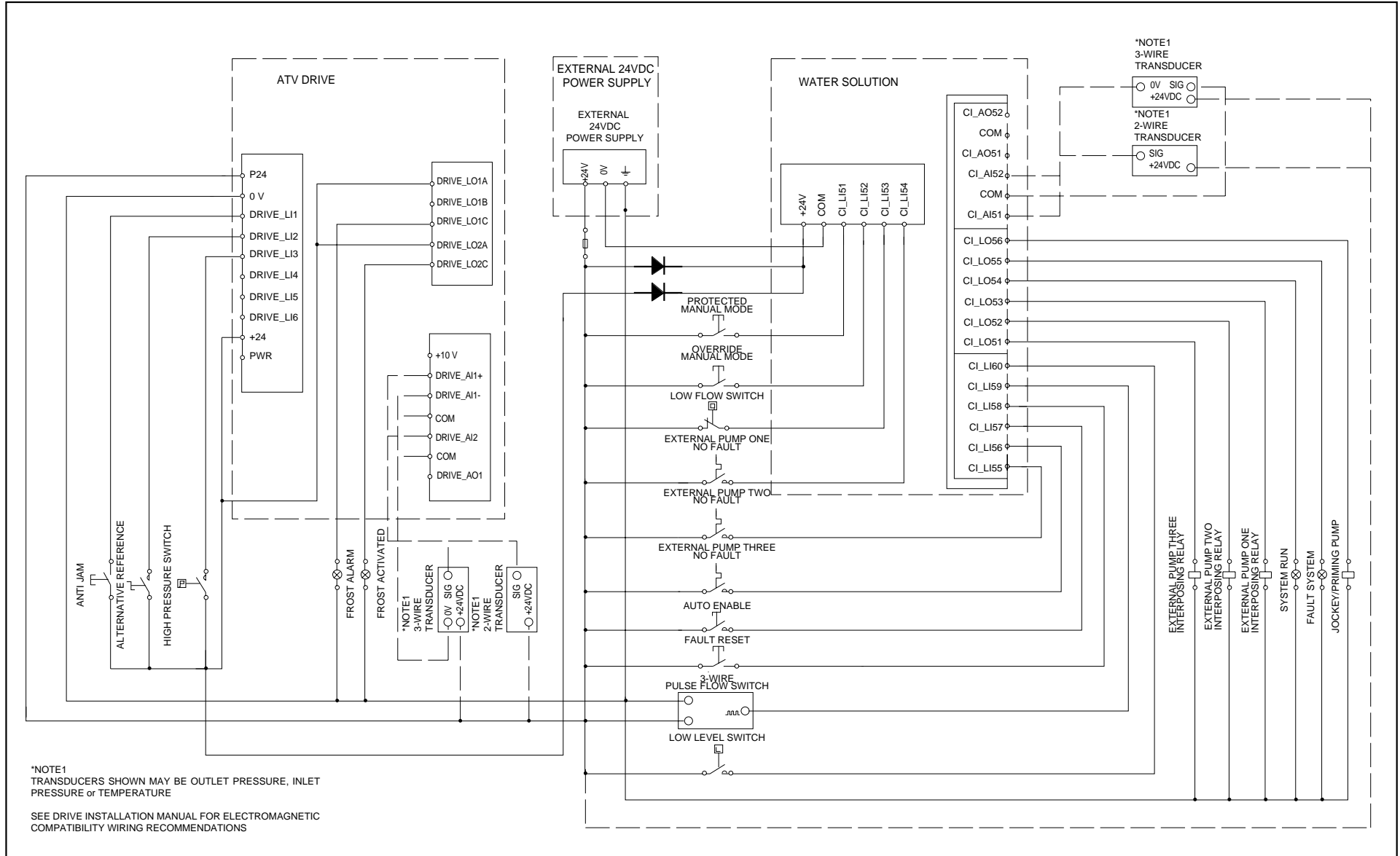

# Water Solution Screen Navigation

---

To begin configuring the Water Solution the user must navigate to the custom screens. This is done in the following way:

Select **[1.14 WATER SOLUT.]** and press enter

NST	APP	0.0Hz	OFF
1,14 WATER SOLUT.			
TIME: 14:00	:		OFF
Flow Display	:	0.00	l/s
Act PID Ref	:	0.0	Bar
Local PID Ref	:	0.0	Bar
Feedback Pres	:	0.0	Bar
Code	<<	>>	Quick

The user will now see the following screen





NST	APP	0.0Hz	OFF
1,14 WATER SOLUT.			
System Status	:		OFF
Alt Local Ref	:	0.0	Bar
◀EXPANSION▶	:		NO
Modbus add Prg C.	:		OFF
DATE/TIME SETTINGS			
Code	<<	>>	Quick

To begin configuring the Water Solution scroll down to **[<EXPANSION>]** and press enter  
Then select **[START SET]**





NST	APP	0.0Hz	OFF
◀EXPANSION▶			
NO			
START SET			✓
SLEEP SET			
RESET FLT			
NRESET FLT			
Code	<<	>>	Quick

# Water Solution Screen Navigation





The following screen is now displayed

NST	APP	0.0Hz	OFF
1,14 WATER SOLUT. 			
<b>←EXPANSION→</b> : <b>START SET</b>			
Start Press	:	0.5	Bar
Start Delay	:	30	sec
Pipe Fill P	:	0.4	Bar
Pipe Fill Spd	:	25	Hz
Code   Quick 			
Pipe Fill Lim	:	10	sec
SetpointRamp	:	0.05	Un/s
Man Speed	:	35	Hz

Once the start settings have been modified, scroll back to **←EXPANSION→** , press enter and then select **Sleep Set**

NST	APP	0.0Hz	OFF
<b>←EXPANSION→</b>			
NO			
START SET			
<b>SLEEP SET</b> 			
RESET FLT			
NRESET FLT			
Code   Quick 			

The following screen is now displayed

NST	APP	0.0Hz	OFF
1,14 WATER SOLUT. 			
<b>←EXPANSION→</b> : <b>SLEEP SET</b>			
Sleep Delay	:	20	sec
Sleep Speed	:	30	Hz
Sleep Flow	:	0	l/s
Sleep Current	:	0.0	A
Code   Quick 			
Flow Sw Sleep	:	Disable	
Adv Sleep	:	Disable	
Adv Check Sp	:	0	Hz
Adv Test Time	:	0	sec
Adv Speed	:	0	Hz
Slp Bst Speed	:	0	Hz
Slp Bst Time	:	0	sec

The same procedure should be followed to configure the variables for the desired functions.

# Pre-configuration

---

To ensure correct operation certain standard drive parameters have been pre-configured to suit the Water Solution. These parameters are preset every time the power is cycled. They are

- **[Ref.1 channel]** (Fr1) = **[Prog.Card]** (APP) = 170
- **[Ref. 2 switching]** (rFC) = **[ch1 active]** (Fr1): No switching, **[Ref.1 channel]** (Fr1) active = 96
- **[Profile]** (CHCF) = **[Not separ.]** (SIM): Reference and command, not separate = 1
- **[Stop Key priority]** (PSt) = **[No]** (nO) = 0
- **[PID feedback ass.]** (PIF) = **[No]** (nO): Function inactive = 0
- **[Freewheel stop ass.]** (nSt) = **[No]** (nO): Not assigned = 0

## **WARNING**

### **RISK OF IMPROPER DRIVE OPERATION**

These parameters should not be modified and will be reinitialised to the above values on cycling of drive power.

**Failure to follow this instruction can result in death, serious injury, or equipment damage.**

# Parameter Guide

The following diagram describes the Parameter Guide

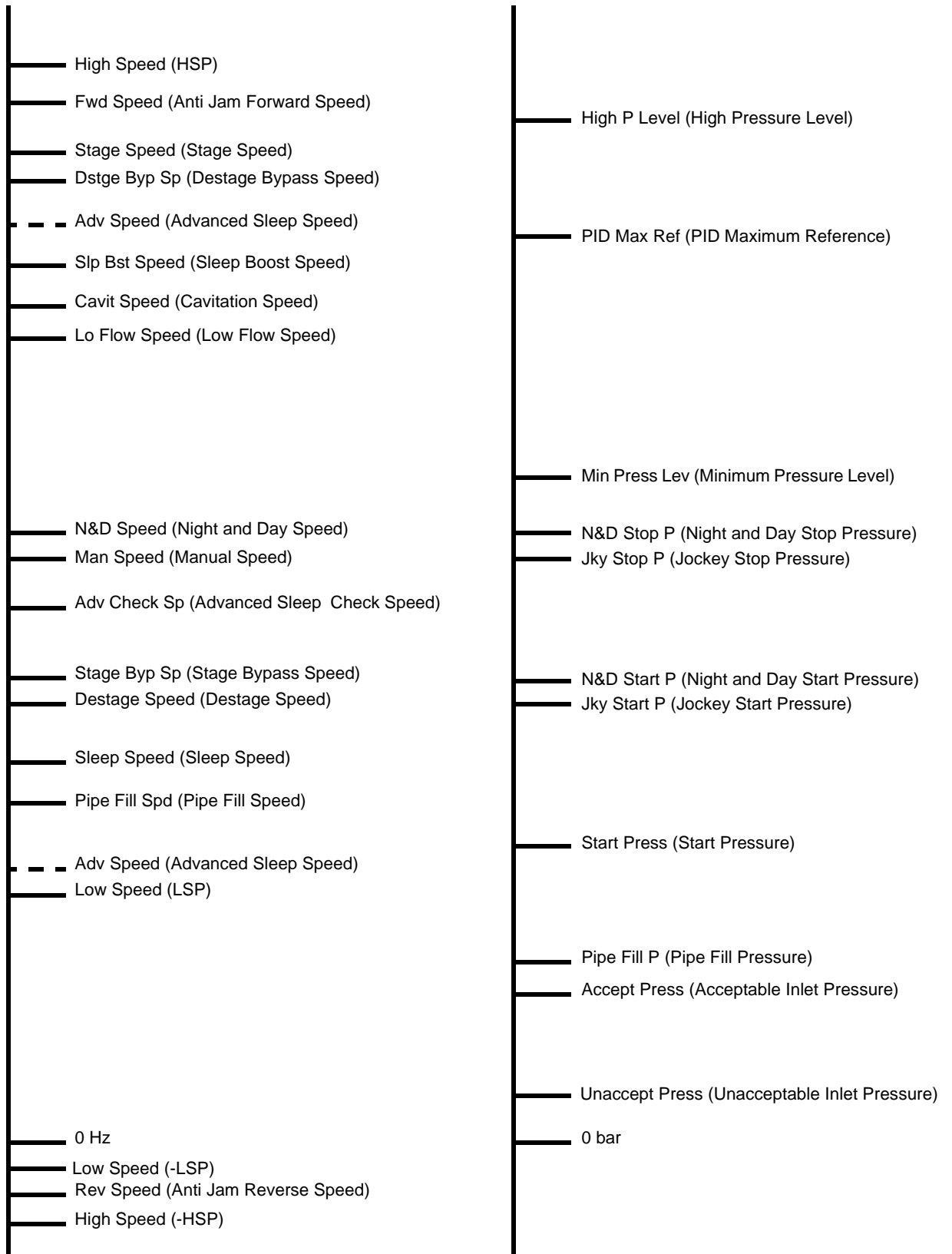

Note: The diagram above represents a scale of the recommended values for speed and pressure. For example, the recommended value for Fwd Speed (Anti Jam Forward Speed) is between High Speed (HSP) and Stage Speed (Stage Speed).

# Parameter Descriptions

---

## [1.14 - WATER SOLUT.] ~ [<EXPANSION>] ~ [START SET] ~

### [Start Press] : (Start Pressure)

Default	0.5
Minimum	[Pipe Fill P]
Maximum	[PID Max Ref]
Unit	%, kPa, bar, psi
Modbus Address	%mw300

On a rising edge from CI\_LI57 (auto run) the system will enter the ready state. If after the [Start Delay], [<EXPANSION>] ~ [START SET] ~ [Start Delay], the feedback pressure is below the start pressure, the drive will start and invoke the pipefill function.

Alternatively the drive will start with no delay if the system has been in auto and entered the sleep condition and the feedback pressure has fallen below the start pressure. Under these conditions the pipefill functions is not invoked.

[See figure 6, page 25](#)

### [Start Delay] : (Start Delay)

Default	30
Minimum	0
Maximum	999
Unit	sec
Modbus Address	%mw302

On a rising edge from CI\_LI57 (auto run) the system will enter the ready state. If after the [Start Delay] the feedback pressure is below the start pressure, the drive will start.

The [Start Delay] is only active on a new start.

[See figure 6, page 25](#)

### [Pipe Fill P] : (Pipe Fill Pressure)

Default	0.4
Minimum	0
Maximum	[Start Press]
Unit	%, kPa, bar, psi
Modbus Address	%mw304

The Pipe Fill function is used to ensure a minimum amount of back-pressure is present before allowing the system to enter PID control. This is to prevent any integral wind-up of the PID controller. If the pipe fill function is not desired then set this parameter to zero. If however the pipe fill function is required, the system will enter pipe fill when the drive performs a new start. The pipe fill function is only re-initialised after a rising edge on CI\_LI57 (auto run) or a system / drive fault.

When the drive first starts the system will enter Pipe fill and display [PIPE FILL] (FILL) as the system status. The system will remain in pipe fill until either the feedback pressure is greater than the value entered for this parameter or the system has been in pipe fill for longer than the time entered in screen [<EXPANSION>] ~ [START SET] ~ [Pipe Fill Lim]. If either of these conditions are met the system will enter setpoint ramp.

[See figure 6, page 25](#)

### [Pipe Fill Spd] : (Pipe Fill Speed)

Default	25
Minimum	LSP
Maximum	HSP
Unit	Hz
Modbus Address	%mw306

When in pipe fill mode, the drive will run at this speed.

[See figure 6, page 25](#)

# Parameter Descriptions

---

## [Pipe Fill Lim] : (Pipe Fill Limit)

Default	10
Minimum	0
Maximum	32767
Unit	sec
Modbus Address	%mw308

If the system has been in pipe fill mode for longer than the time entered in this screen it will enter setpoint ramp mode regardless of the feedback pressure.

This parameter is useful to protect the system from remaining in pipe fill when a large demand is present and the system will never get the feedback pressure to a value greater than the value entered in [**<EXPANSION>**] ~ [**START SET**] ~ [**Pipe Fill P**].

[See figure 6, page 25](#)

## [Setpoint Ramp] : (Setpoint Ramp)

Default	0.05
Minimum	0.01
Maximum	327.67
Unit	Un/s(units per second)
Modbus Address	%mw310

Setpoint ramp is used to prevent integral wind-up of the PID controller during a start sequence. If the selected setpoint is applied directly to the PID controller when the feedback pressure is low, the large error will cause the PID to make large motor speed adjustments to overcome this error. This can result in pressure spikes and water hammer. By ramping the setpoint up at a rate the system can effectively manage, this problem is overcome. The ramp rate is selected in (user selected) units per second.

Assuming the system has left Pipe fill mode and the feedback at this point is 2.0 bar then if the selected setpoint is 4.0 bar and the ramp rate set is 0.2 units/sec then the setpoint will take 10 seconds to ramp up to 4.0 bar.

During setpoint ramp the system status will display [**SET RAMP**] (RAMP). This will remain displayed until the applied setpoint has reached the selected setpoint and the pressure feedback is greater than or equal to the selected setpoint.

Please note that the system will stage external pumps if staging permissives are met.

[See figure 6, page 25](#)

## [Man Speed] : (Manual Speed)

Default	35
Minimum	LSP
Maximum	HSP
Unit	Hz
Modbus Address	%mw312

CI_LI51	Protected Manual Mode
CI_LI52	Override manual Mode
CI_LI57	Auto Run

The three pump modes are mutually exclusive so if any more than one of the above inputs is true the system is locked out and the status display will show [**LOCK OUT**] (LOCK).

If however CI\_LI51 only is true the status display will show [**PRO MAN**] (Pmm) and the speed reference will be that set in this screen. All system safeties are still valid in this mode, high pressure, etc.

CI\_LI52 only is true the status display will show [**OVER MAN**] (Omm) and the speed reference will be that set in this screen. No system safeties are valid in this mode, high pressure etc is ignored.

# Parameter Descriptions

## Start Settings

The diagram below describes the Start Settings

Figure 6

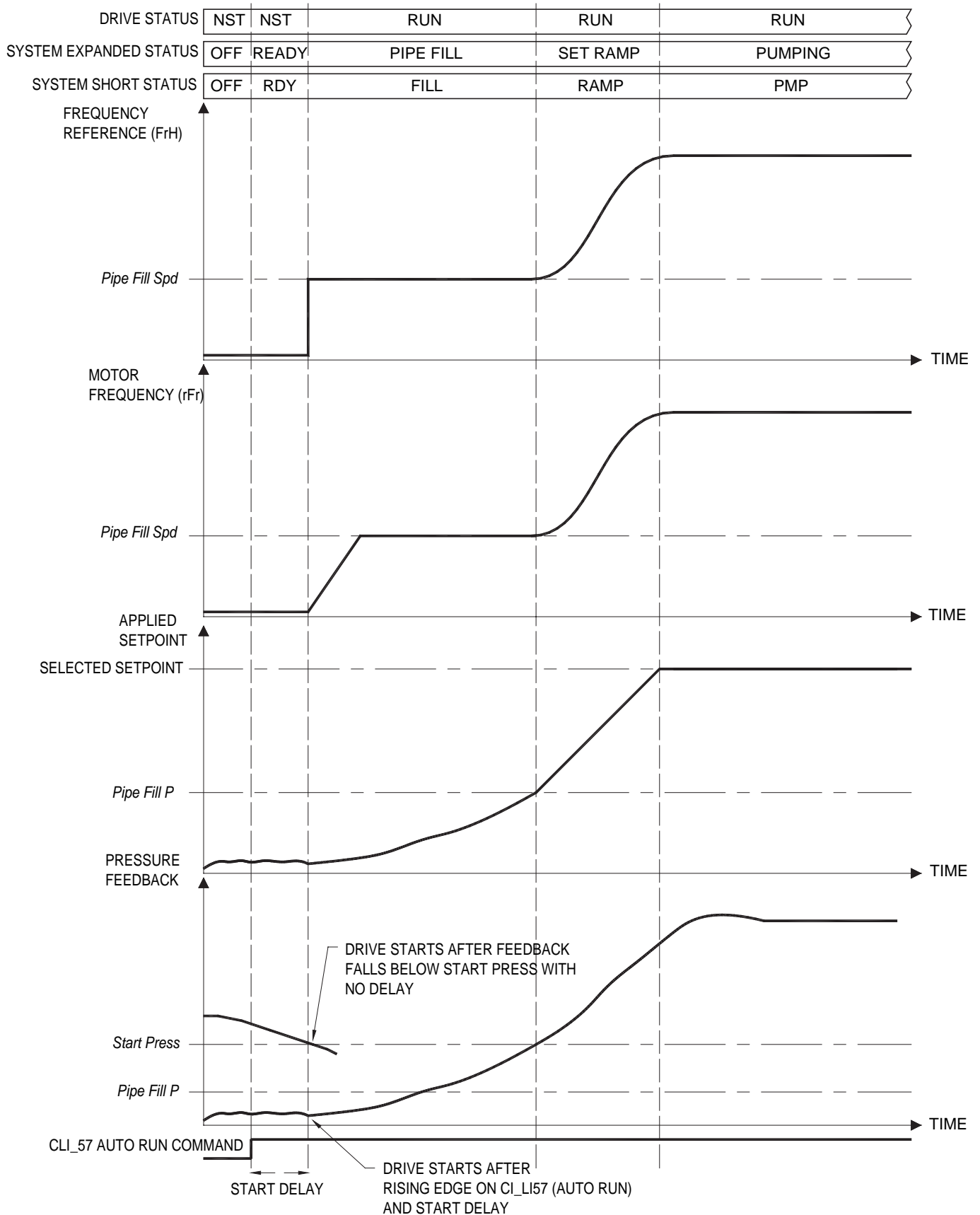

Note: Pipefill only occurs on rising edge after on CI\_LI57 (Autorun)

# Parameter Descriptions

---

## [1.14 - WATER SOLUT.] ~ [<EXPANSION>] ~ [SLEEP SET] ~

### [Sleep Delay] : (Sleep Delay)

Default	20
Minimum	0
Maximum	3600
Unit	sec
Modbus Address	%mw314

If the sleep function permissives are met, the drive will switch off and enter the sleep state after this delay.

[See figure 7, page 29](#)

### [Sleep Speed] : (Sleep Speed)

Default	30
Minimum	LSP
Maximum	HSP
Unit	Hz
Modbus Address	%mw316

If the drive speed falls below this value after the pipefill function, the sleep delay timer is started. During the sleep delay time the status will display **[SLEEP FUN]** (SLFU). If the speed remains below this value for longer than the sleep delay time, the drive will accelerate to the sleep boost speed for the sleep boost time and then stop and enter the sleep state. The status will now display **[SLEEP]** (SLP).

[See figure 7, page 29](#)

### [Sleep Flow] : (Sleep Flow)

Default	0.00
Minimum	0
Maximum	65535
Unit	%, l/s, l/m, l/hr
Modbus Address	%mw318

If the flow falls below this value, after the pipefill function, the sleep delay timer is started. During the sleep delay time the status will display **[SLEEP FUN]** (SLFU). If the flow remains below this value for longer than the sleep delay time the drive will accelerate to the sleep boost speed for the sleep boost time and then stop and enter the sleep state. The status will now display **[SLEEP]** (SLP).

[See figure 7, page 29](#)

### [Sleep Current] : (Sleep Current)

Default	0.0
Minimum	0
Maximum	2 * Drive rated current
Unit	A
Modbus Address	%mw320

If the motor current falls below this value, after the pipefill function, the sleep delay timer is started. During the sleep delay time the status will display **[SLEEP FUN]** (SLFU). If the current remains below this value for longer than the sleep delay time, the drive will accelerate to the sleep boost speed for the sleep boost time and then stop and enter the sleep state. The status will now display **[SLEEP]** (SLP).

[See figure 7, page 29](#)

# Parameter Descriptions

---

## [Flow Sw Sleep] : (Flow Switch Sleep)

Default	[Disable]
Range	[Disable] or [Enable]
Modbus Address	%mw322

This parameter allows the user to select whether the flow switch (if installed) is used to instigate the sleep function. If enabled and if the CI\_LI53 input is not active, after the pipefill function, the sleep delay timer is started. During the sleep delay time the status will display **[SLEEP FUN]** (SLFU). If input CI\_LI53 remains inactive for longer than the sleep delay time the drive will accelerate to the sleep boost speed for the sleep boost time and then stop and enter the sleep state. The status will now display **[SLEEP]** (SLP).

[See figure 7, page 29](#)

## [Adv Sleep] : (Advanced Sleep)

Default	[Disable]
Range	[Disable] or [Enable]
Modbus Address	%mw324

This parameter allows the user to select whether the advanced sleep function is used.

[See figure 8, page 30](#)

[See figure 9, page 31](#)

## [Adv Check Sp] : (Advanced Check Speed)

Default	0
Minimum	LSP
Maximum	HSP
Unit	Hz
Modbus Address	%mw326

If a fall in demand doesn't cause either a significant fall in speed, or current, the advanced sleep function is used to periodically monitor the demand. This is typically required when the pump curve is particularly flat and a flow switch and or meter is not installed.

If the drive speed is below the value entered here, for greater than the time entered in screen [**<EXPANSION>**] ~ **[SLEEP SET]** ~ **[Adv Test Time]**, the system will revert to the speed reference entered in screen [**<EXPANSION>**] ~ **[SLEEP SET]** ~ **[Adv Speed]**. While adjusting the speed to this new value the PID is disabled to prevent integral wind-up effects when leaving the advanced sleep function. As soon as the Adv Speed is achieved the system reverts to PID control. There are two usual methods of checking for no demand, they are overspeed testing and underspeed testing.

In the case of overspeed testing the **[Adv Speed]** is set above the **[Adv Check Sp]** which will cause a negative error on the PID (setpoint-feedback) if no demand is present. This in turn will cause the system to begin reducing the motor speed. As there is no demand the PID error will remain and the motor speed will continue to be reduced until the minimum speed (LSP) is reached. When commissioned correctly this will cause the system to enter the sleep mode.

In the case of underspeed testing the **[Adv Speed]** is set below parameter [**<EXPANSION>**] ~ **[SLEEP SET]** ~ **[Sleep Speed]** which will cause no error on the PID (setpoint-feedback) if no demand is present. As there is no demand there will be no PID error and therefore the system will maintain motor speed below **[Sleep Speed]**. When commissioned correctly this will cause the system to enter the sleep mode.

[See figure 8, page 30](#)

[See figure 9, page 31](#)

## [Adv Test Time] : (Advanced Test Time)

Default	0
Minimum	0
Maximum	9999
Unit	sec
Modbus Address	%mw328

Before the advanced sleep function is activated, make sure that the motor speed has been below **[Adv Speed]** for a duration longer than **[Adv Test Time]**.

[See figure 8, page 30](#)

[See figure 9, page 31](#)

# Parameter Descriptions

---

## **[Adv Speed] : (Advanced Speed)**

Default	0
Minimum	LSP
Maximum	HSP
Unit	Hz
Modbus Address	%mw330

If the advanced sleep function is active the system will revert to this speed reference.

[See figure 8, page 30](#)

[See figure 9, page 31](#)

## **[Slp Bst Speed] : (Sleep Boost Speed)**

Default	0
Minimum	LSP
Maximum	HSP
Unit	Hz
Modbus Address	%mw332

Immediately prior to entering the sleep state the drive output frequency is set at the value entered in this screen for the time entered in screen [**<EXPANSION>**] ~ [**SLEEP SET**] ~ [**Slp Bst Time**].

[See figure 7, page 29](#)

[See figure 8, page 30](#)

[See figure 9, page 31](#)

## **[Slp Bst Time] : (Sleep Boost Time)**

Default	0
Minimum	0
Maximum	32767
Unit	sec
Modbus Address	%mw334

Immediately prior to entering the sleep state the drive output frequency is set to [**Slp Bst Speed**] for the time entered in this screen.

[See figure 7, page 29](#)

[See figure 8, page 30](#)

[See figure 9, page 31](#)

# Parameter Descriptions

## Standard Sleep Functions

The diagram below describes the Standard Sleep Functions

Figure 7

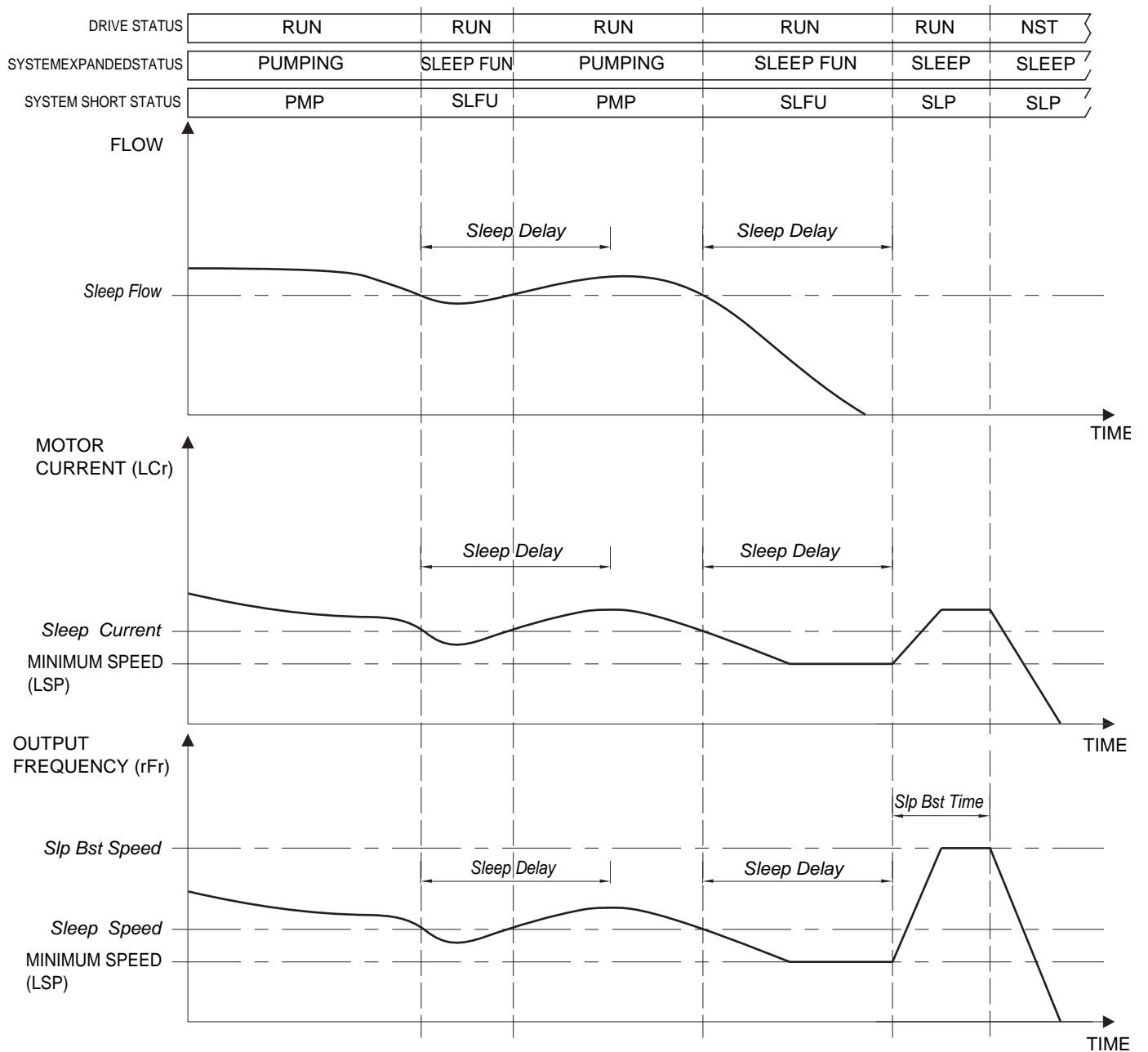

# Parameter Descriptions

## Overspeed Advanced Sleep Function

The table below describes the Overspeed Advanced Sleep Function  
Figure 8

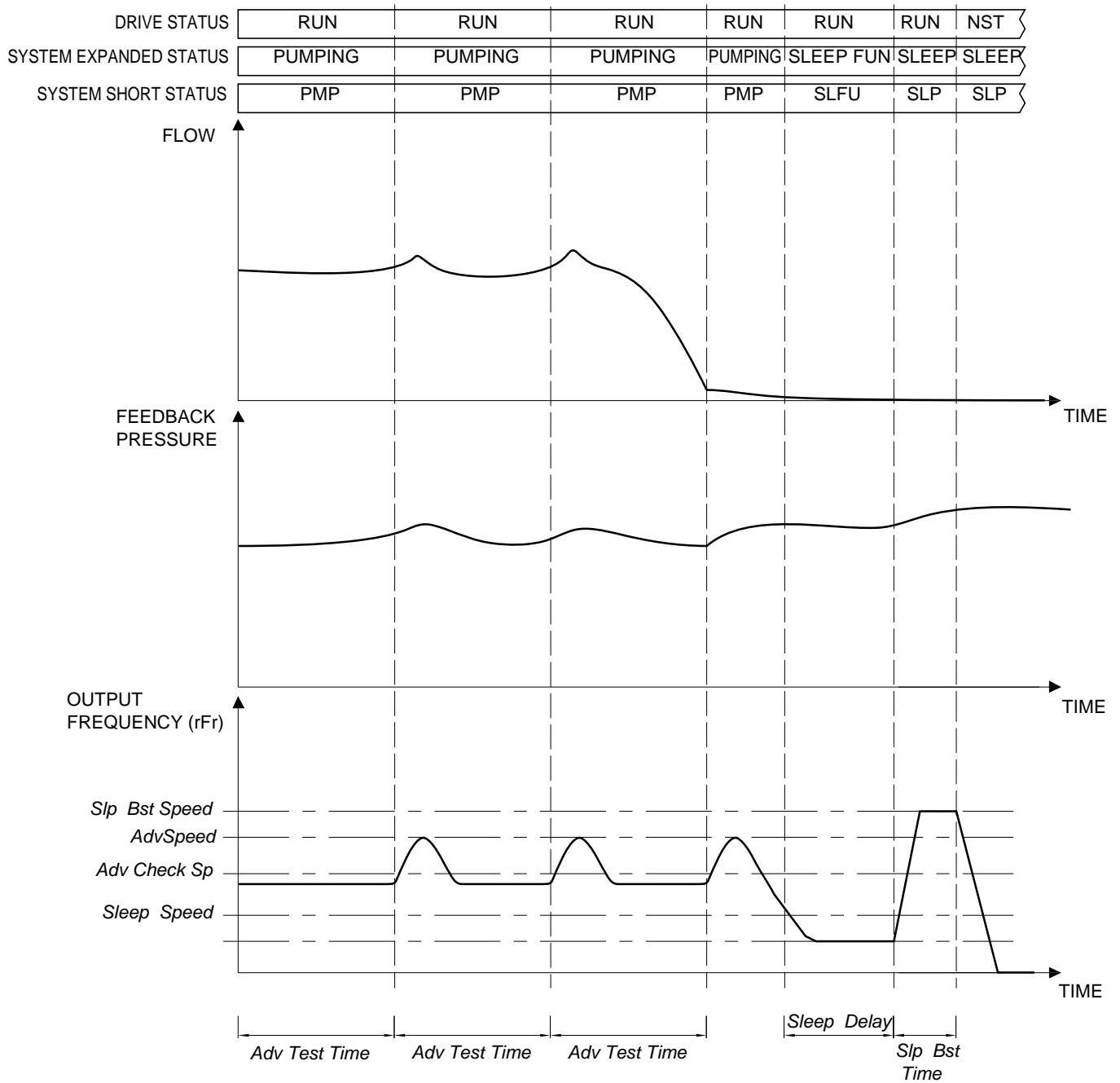

# Parameter Descriptions

## Underspeed Advanced Sleep Function

Figure 9

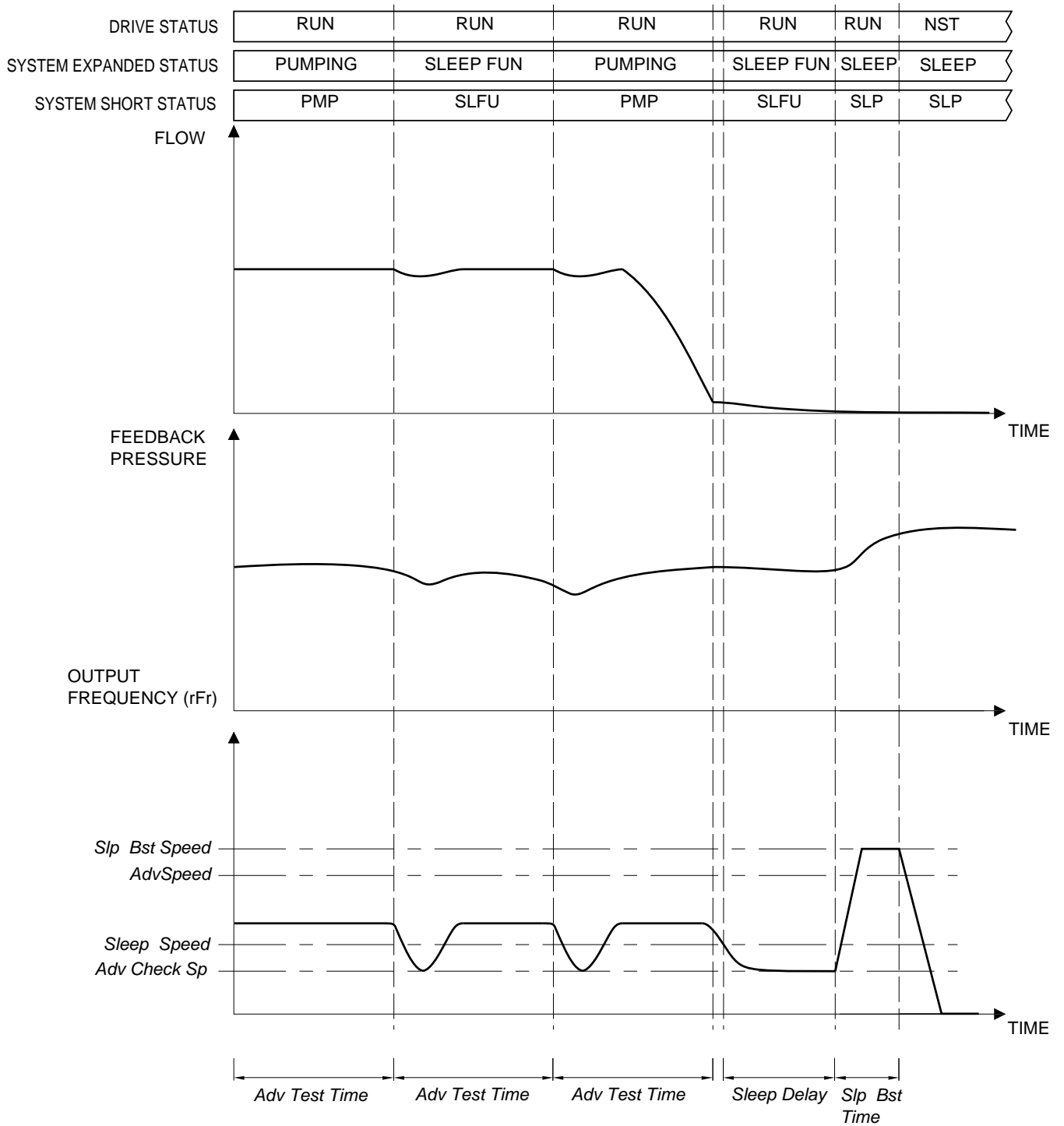

# Parameter Descriptions

---

## [1.14 - WATER SOLUT.] ~ [<EXPANSION>] ~ [RESET FTL] ~

### [No Reset Att] : (Number of Reset Attempts)

Default	5
Minimum	0
Maximum	10
Modbus Address	%mw336

If any of the resettable faults, high pressure, cavitation or low flow have their auto reset functionality enabled, the number entered in this screen is the number of resets that will be performed for that particular fault. These attempts will be made at intervals set by parameter [<EXPANSION>] ~ [RESET FLT] ~ [Reset Pause]

If the system trips more times than set in this screen within the time set in screen [<EXPANSION>] ~ [RESET FLT] ~ [Att Time], no reset will be performed and the system will need to be reset by activating the reset (digital input CI\_LI58), toggling the auto run command (digital input CI\_LI57) or pressing the stop reset button on the operator display. By resetting the system all fault counters are reset to zero. These fault counters are cumulative in that they are not reset to zero each time the [Decrement Dly] rolls over but have the individual counter decremented by one. This means that if there are three consecutive high pressure faults it will take three times [Decrement Dly] before the high pressure counter is reset to zero.

[See figure 11, page 38](#)

### [Decrement Dly] : (Decrement Delay)

Default	3600
Minimum	0
Maximum	9999
Unit	sec
Modbus Address	%mw338

The faults high pressure, cavitation and low flow can be configured to have no consequence, to trip the system or to trip the system with auto reset capability. If auto reset is selected in screens

[<EXPANSION>] ~ [RESET FLT] ~ [Hi P Fault] or  
[<EXPANSION>] ~ [RESET FLT] ~ [Cavit Fault] or  
[<EXPANSION>] ~ [RESET FLT] ~ [Flow Fault]

and if the respective individual fault counter is below [No Reset Att] and it that fault has caused the system to trip, then the system will reset after the delay set in screen [<EXPANSION>] ~ [RESET FLT] ~ [Reset Pause]. If however the respective fault counter is equal to [No Reset Att] then no reset will be performed and the system will need to be reset by activating the reset (digital input CI\_LI58), toggling the auto run command (digital input CI\_LI57) or by cycling the power to the drive / water solution combination.

[See figure 11, page 38](#)

### [Reset Pause] : (Reset Pause)

Default	3600
Minimum	0
Maximum	9999
Unit	sec
Modbus Address	%mw340

The three faults able to be reset, high pressure, cavitation and low flow, are able to be configured to have no consequence, to trip the system or to trip the system with auto reset capability. If auto reset is selected in screens

[<EXPANSION>] ~ [RESET FLT] ~ [Hi P Fault] or  
[<EXPANSION>] ~ [RESET FLT] ~ [Cavit Fault] or  
[<EXPANSION>] ~ [RESET FLT] ~ [Flow Fault]

and if the respective individual fault counter is below [No Reset Att] and if that fault has caused the system to trip, then the system will reset after the delay set in this screen. If however the respective fault counter is equal to [No Reset Att], then no reset will be performed and the system will need to be reset by activating the reset (digital input CI\_LI58), toggling the auto run command (digital input CI\_LI57) or by cycling the power to the drive / water solution combination.

[See figure 11, page 38](#)

# Parameter Descriptions

---

## [Hi P Fault] : (High Pressure Fault)

Default	Disable
Range	[Disable], [Enable] or [Aut Reset]
Modbus Address	%mw342

This screen is used to select the desired response to a high pressure fault sensed either by drive digital input Drive\_LI3 being inactive for more than one second or by the measured analogue pressure feedback being greater than [High P Level] for longer than [Hi P Delay].

If [Disable] is selected then no action is taken by the system if a high pressure is detected.

If [Enable] is selected and a high pressure is detected the system will trip and display [HI PRESS]. Pushing Function key F1 will show the fault screen relevant to whether the fault was caused by the digital or analogue high pressure protection.

If [Aut Reset] is selected and a high pressure is detected the system will trip and display [HI PRESS]. Pushing Function key F1 will show the fault screen relevant to whether the fault was caused by the digital or analogue high pressure protection. After the time delay [Reset Pause] the system will automatically reset as long as the respective individual fault counter is less than [No Reset Att].

## [Hi P Level] : (High Pressure Level)

Default	5.0
Minimum	0
Maximum	3276.7
Unit	%, kPa, bar, psi
Modbus Address	%mw344

A high pressure is detected when the feedback pressure is greater than the value entered in this screen for longer than [Hi P Delay].

## [Hi P Delay] : (High Pressure Delay)

Default	10
Minimum	0
Maximum	999
Unit	sec
Modbus Address	%mw346

A high pressure is detected when the feedback pressure is greater than [Hi P Level] for longer than the value entered in this screen.

## [Cavit Fault] : (Cavitation Fault)

Default	[Disable]
Range	[Disable], [Enable] or [Aut Reset]
Modbus Address	%mw348

This screen is used to select the desired response to a cavitation fault sensed by the motor current being less than [Cavit Current] while the motor speed is above [Cavit Speed] for longer than [Cavit Delay].

If [Disable] is selected then no action is taken by the system if cavitation is detected.

If [Enable] is selected and cavitation is detected the system will trip and display [CAVITATION]. Pushing Function key F1 will show the fault screen relevant to the fault.

If [Aut Reset] is selected and cavitation is detected the system will trip and display [CAVITATION]. Pushing Function key F1 will show the fault screen relevant to the fault. After the time delay [Reset Pause] the system will automatically reset as long as the respective individual fault counter is less than [No Reset Att].

[See figure 11, page 38](#)

# Parameter Descriptions

---

## [Cavit Current] : (Cavitation Current)

Default	0
Minimum	0
Maximum	2 * Drive rated current
Unit	A
Modbus Address	%mw350

Cavitation is detected when the motor current is below the value entered in this screen while the motor speed is above [Cavit Speed] for longer than [Cavit Delay].

[See figure 11, page 38](#)

## [Cavit Speed] : (Cavitation Speed)

Default	50
Minimum	LSP
Maximum	HSP
Unit	Hz
Modbus Address	%mw352

Cavitation is detected when the motor speed is above the value entered in this screen while the motor current is below [Cavit Current] for longer than [Cavit Time].

[See figure 11, page 38](#)

## [Cavit Time] : (Cavitation Time)

Default	10
Minimum	0
Maximum	999
Unit	sec
Modbus Address	%mw354

Cavitation is detected when the motor speed is above [Cavit Speed] while the motor current is below [Cavit Current] for longer than the value entered in this screen.

[See figure 11, page 38](#)

## [Flow Fault] : (Flow Fault)

Default	[Disable]
Range	[Disable], [Enable] or [Aut Reset]
Modbus Address	%mw356

This screen is used to select the desired response to a flow fault.

There are two ways the system detects a flow fault, either by sensing digital input CI\_LL153 is inactive or by the flow feedback being below [Lo Flow Level]. The user selects which sensing mechanism to use in screen [<EXPANSION>] ~ [RESET FLT] ~ [Lo Flow Sel].

Regardless of the sensing mechanism selected, low flow protection can be disabled during pipe fill. This is done in screen [<EXPANSION>] ~ [RESET FLT] ~ [Fill Flow Pro].

In the case [Fill Flow Pro] was set to [No] (no protection during pipefill) and [Flow Rate] or [Either] was selected in screen [<EXPANSION>] ~ [RESET FLT] ~ [Lo Flow Sel], on completion of the Pipe Fill function and the low flow protection start delay, [Lo Flo Delay], a low flow fault occurs if the flow feedback is below [Lo Flow Level] for longer than [Lo Flo Filter] and the motor speed is above [Lo Flo Speed].

Alternatively, in the case [Fill Flow Pro] was set to [No] (no protection during pipefill) and [Flow Sw] or [Either] was selected in screen [<EXPANSION>] ~ [RESET FLT] ~ [Lo Flow Sel], on completion of the Pipe Fill function and the low flow protection start delay, [Lo Flo Delay], a low flow fault occurs if digital input CI\_LL153 is inactive for longer than [Lo Flo Filter] and the motor speed is above [Lo Flo Speed].

# Parameter Descriptions

---

If **[Disable]** is selected in this screen then no action is taken by the system if low flow is detected.

Alternatively if **[Enable]** is selected and a flow fault is generated due to flow feedback the system will trip and display **[FLOW RATE]**. If a flow fault is generated due to digital input CI\_LI53 being inactive the system will trip and display **[NO FLOW]**. Pushing Function key F1 will show the fault screen relevant to the fault.

Alternatively if **[Aut Reset]** is selected and a flow fault is generated due to flow feedback the system will trip and display **[FLOW RATE]**. If a flow fault is generated due to digital input CI\_LI53 being inactive the system will trip and display **[NO FLOW]**. Pushing Function key F1 will show the fault screen relevant to the fault. After the time delay **[Reset Pause]** the system will automatically reset as long as the respective individual fault counter is less than **[No Reset Att]**.

[See figure 10, page 37](#)

## **[Lo Flow Sel] : (Low Flow Selection)**

Default	<b>[Flow Sw]</b>
Range	<b>[Flow Rate], [Flow Sw] or [Either]</b>
Modbus Address	%mw358

This screen selects whether the flow feedback, the flow switch or both are used to trip the system under low flow conditions.

[See figure 10, page 37](#)

## **[Lo Flo Level] : (Low Flow Level)**

Default	0
Minimum	0
Maximum	327.67
Unit	%, l/s, l/m, l/hr
Modbus Address	%mw360

If **[Flow Rate]** or **[Either]** is selected in screen **[Lo Flow Sel]**, then the flow rate must be below this level for a flow rate generated fault to occur.

[See figure 10, page 37](#)

## **[Lo Flo Speed] : (Low Flow Speed)**

Default	25
Minimum	LSP
Maximum	HSP
Unit	Hz
Modbus Address	%mw362

The motor speed must be above the value entered in this screen for a flow fault to be generated.

[See figure 10, page 37](#)

## **[Lo Flo Delay] : (Low Flow Delay)**

Default	30
Minimum	0
Maximum	999
Unit	sec
Modbus Address	%mw364

If low flow protection during Pipe Fill is enabled in screen **[Fill Flow Pro]** then as soon as the drive starts the Low Flow Delay is started. A flow fault can only occur after this delay has timed out.

Alternatively, if low flow protection during Pipe Fill is disabled in screen **[Fill Flow Pro]** then as soon as the the Pipe Fill has finished the **[Lo Flo Delay]** is started. A flow fault can only occur after this delay has timed out.

[See figure 10, page 37](#)

# Parameter Descriptions

---

## [Lo Flo Filter] : (Low Flow Filter)

Default	2
Minimum	0
Maximum	999
Unit	sec
Modbus Address	%mw366

After **[Lo Flo Delay]** the flow rate or flow switch permissives must be met for greater than this time before the system will trip. This value is a de-bounce time to prevent nuisance faults.

[See figure 10, page 37](#)

## [Fill Flow Pro] : (Fill Flow Protection)

Default	<b>[NO]</b>
Range	<b>[NO]</b> or <b>[YES]</b>
Modbus Address	%mw368

If this function is enabled (**[YES]** selected) the low flow protection is active during pipe fill. In this case, the **[Lo flo delay]** starts at the beginning of the pipe filling.

If disabled (**[NO]** selected) the low flow protection is only active after pipe fill has finished. In this case, the **[Lo flo delay]** starts after the pipe and the ramp.

[See figure 10, page 37](#)

# Parameter Descriptions

## Resettable Faults

The following diagrams describe the Resettable Faults

Figure 10

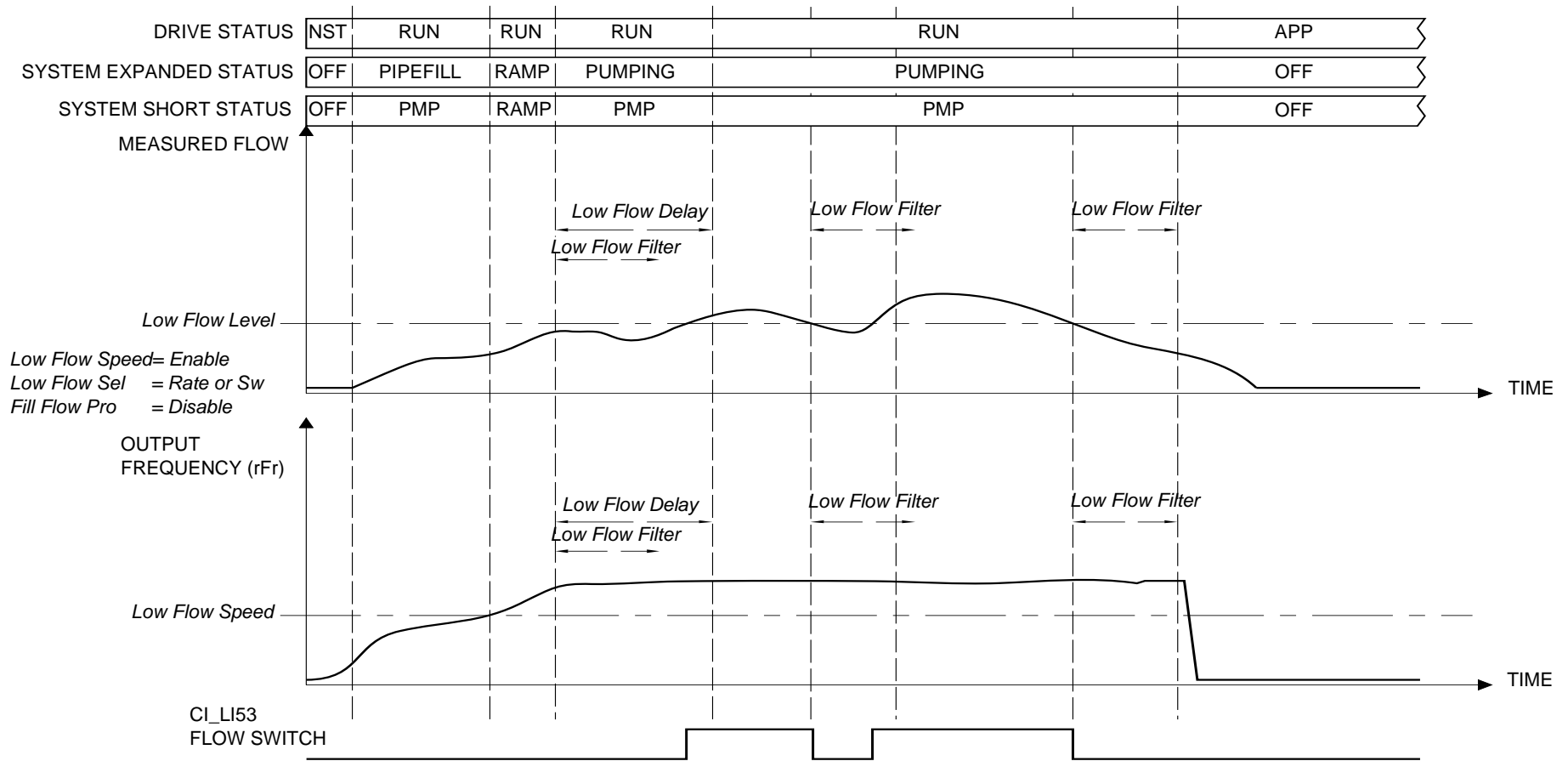

# Parameter Descriptions

Figure 11

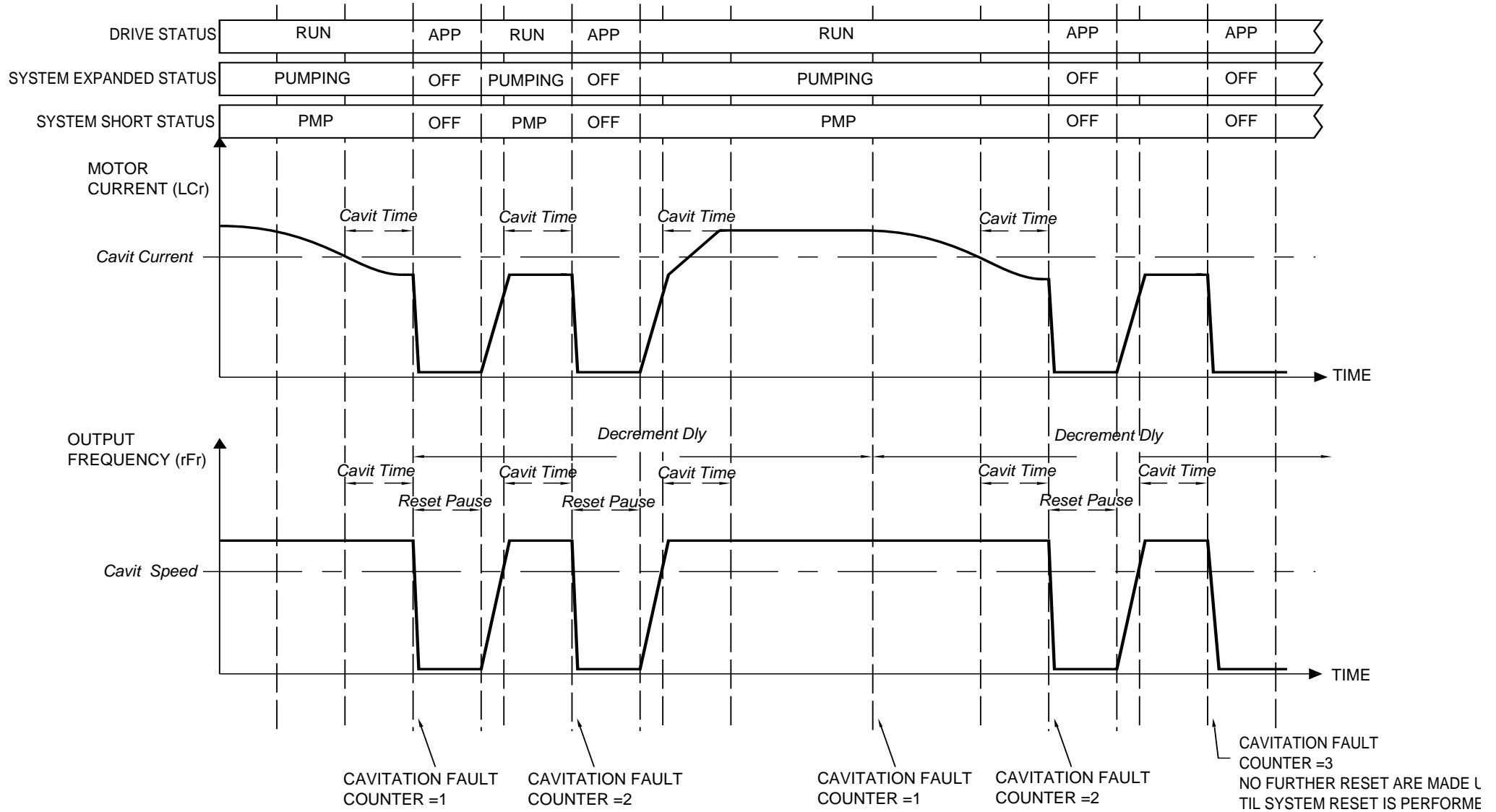

# Parameter Descriptions

---

## [1.14 - WATER SOLUT.] ~ [<EXPANSION>] ~ [RESET FTL] ~

### [Cycle Time] : (Cycle Time)

Default	60
Minimum	0
Maximum	3600
Unit	sec
Modbus Address	%mw370

If the drive restart more times than [<EXPANSION>] ~ [NRESET FLT] ~ [Cycle Count] in a time defined in [<EXPANSION>] ~ [NRESET FLT] ~ [Cycle Time], the system will trip and require a reset via activation of CI\_LI58, toggling the auto command (CI\_LI57) or pushing the drive stop/reset button.

### [Cycle Count] : (Cycle count)

Default	3
Minimum	0
Maximum	99
Modbus Address	%mw372

If the drive restart more times than [<EXPANSION>] ~ [NRESET FLT] ~ [Cycle Count] in a time defined in [<EXPANSION>] ~ [NRESET FLT] ~ [Cycle Time], the system will trip and require a reset via activation of CI\_LI58, toggling the auto command (CI\_LI57) or pushing the drive stop/reset button.

[See figure 12, page 40](#)

### [Min Press Flt] : (Minimum Pressure Fault)

Default	[Disable]
Range	[Disable] or [Enable]
Modbus Address	%mw374

If the drive is running and the system is not in Override Manual mode and the feedback pressure is less than [<EXPANSION>] ~ [NRESET FLT] ~ [Min Press Lev] for longer than [<EXPANSION>] ~ [NRESET FLT] ~ [Min Press Dly] the system will trip and display [MIN PRESS].

### [Min Press Lev] : (Minimum Pressure Level)

Default	0.0
Minimum	0.0
Maximum	3276.7
Unit	%, kPa, bar, psi
Modbus Address	%mw376

If the drive is running and the system is not in Override Manual mode and the feedback pressure is less than [<EXPANSION>] ~ [NRESET FLT] ~ [Min Press Lev] for longer than [<EXPANSION>] ~ [NRESET FLT] ~ [Min Press Dly] the system will trip and display [MIN PRESS].

### [Min Press Dly] : (Minimum Pressure Delay)

Default	10
Minimum	0
Maximum	3600
Unit	sec
Modbus Address	%mw378

If the drive is running and the system is not in Override Manual mode and the feedback pressure is less than [<EXPANSION>] ~ [NRESET FLT] ~ [Min Press Lev] for longer than [<EXPANSION>] ~ [NRESET FLT] ~ [Min Press Dly] the system will trip and display [MIN PRESS].

# Parameter Descriptions

## [Low Level] : (Low Level)

Default	[Disable]
Range	[Disable] or [Enable]
Modbus Address	%mw380

If the drive is running and the system is not in Override Manual mode and digital input CI\_LI60 is inactive for longer than [**EXPANSION**] ~ [NRESET FLT] ~ [Low Lev Dly] and this screen is set to [Enable] the system will trip and display [LOW LEVEL].

## [Low Level Dly] : (Low Level Delay)

Default	2
Minimum	0
Maximum	3600
Unit	sec
Modbus Address	%mw382

If the drive is running and the system is not in Override Manual mode and digital input CI\_LI60 is inactive for longer than the time entered in this screen and [Low Lev] is set to [Enable], the system will trip and display [LOW LEVEL].

## Reset

The following diagram describes the Cycle Count as a function of the Cycle Time  
Figure 12

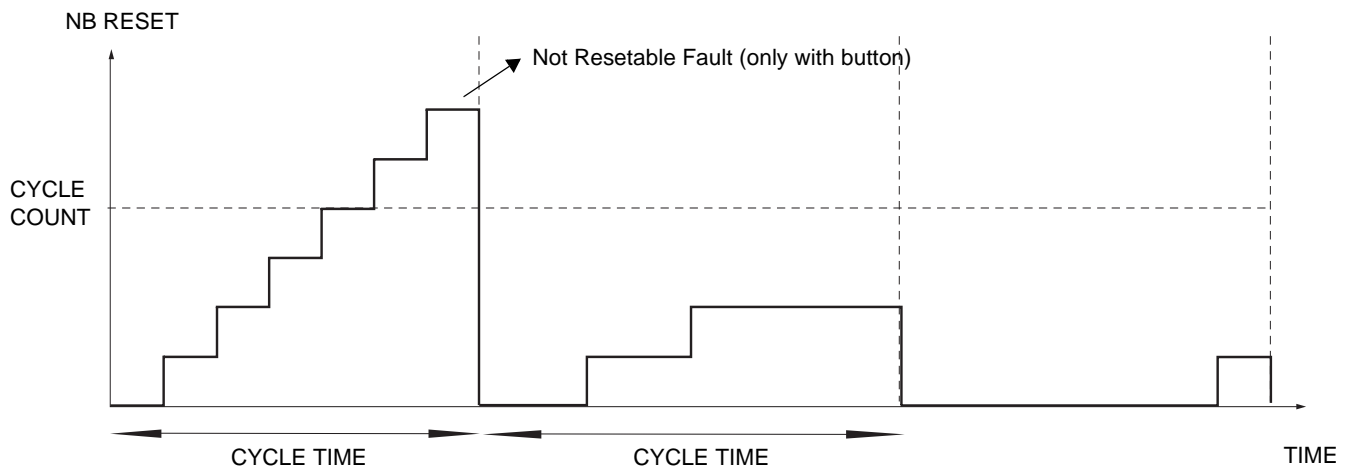

# Parameter Descriptions

---

## [1.14 - WATER SOLUT.] ~ [<EXPANSION>] ~ [SENSORS] ~

### [Outlet TX Max] : (Outlet Transducer Maximum)

Default	10.0
Minimum	0.1
Maximum	3276.7
Unit	%, kPa, bar, psi
Modbus Address	%mw384

This screen is used to inform the system of the range of the transducer being used to measure outlet / discharge pressure. It is always assumed that the minimum is zero (i.e., a 0-10 bar transducer would be selected rather than a 2-10 bar device). If the transducer used is a 4-20 mA and 0-10.0 bar device then 10.0 should be entered in this screen.

Please note that if one of the Water Solution analogue inputs is used for outlet / discharge pressure, it must be correctly configured in screens [<EXPANSION>] ~ [CONFIG] ~ [CI\_AI51 Type] or [<EXPANSION>] ~ [CONFIG] ~ [CI\_AI52 Type] respectively.

### [Inlet TX Max] : (Inlet Transducer Maximum)

Default	10.0
Minimum	0.1
Maximum	3276.7
Unit	%, kPa, bar, psi
Modbus Address	%mw386

This screen is used to inform the system of the range of the transducer being used to measure Inlet / suction pressure. It is always assumed that the minimum is zero i.e., a 0-10 bar transducer would be selected rather than a 2-10 bar device. If the transducer used is a 4-20 mA and 0-10.0 bar device then 10.0 should be entered in this screen.

Please note that if one of the Water Solution analogue inputs is used for Inlet / suction pressure, it must be correctly configured in screens [<EXPANSION>] ~ [CONFIG] ~ [CI\_AI51 Type] or [<EXPANSION>] ~ [CONFIG] ~ [CI\_AI52 Type] respectively.

### [Press Units] : (Pressure Units)

Default	bar
Range	%, kPa, bar and psi
Modbus Address	%mw388

This screen sets the unit displayed for all other screens that display or allow modification of a pressure value. The unit selected is for display purposes only and in no way affects any numerical values.

When changing the unit for display the other screens in this sub-group [WATER SOLUT.] ~ [<EXPANSION>] ~ [SENSORS] ~ are not updated until another sub-group is selected and this one is re-entered.

Please note that if other unit than pressure is selected, it will switch back to a pressure unit.

# Parameter Descriptions

## [Flow Source] : (Flow Source)

Default	[NONE]
Range	[NONE], CI_LI59, DRIVE_AI1, DRIVE_AI2, DRIVE_AI3, DRIVE_AI4, CI_AI51, CI_AI52
Modbus Address	%mw390

This screen configures what type of transducer is used to measure flow. If a pulse flow meter is used, CI\_LI59 must be selected. If an analogue meter is used, one of the listed analogue sources should be selected. If no flow transducer is used [NONE] should be selected.

Please note the following:

- 1 If one of the Water Solution analogue inputs is used, it must be correctly configured in screens [<EXPANSION>] ~ [CONFIG] ~ [CI\_AI51 Type] or [<EXPANSION>] ~ [CONFIG] ~ [CI\_AI52 Type] respectively.
- 2 If any of the analogue sources are selected the adjustable range is dependent on the flow unit that is selected in screen [<EXPANSION>] ~ [SENSORS] ~ [Flow Units].

If Liters / s is selected there will be two decimal places.

If Liters / m is selected there will be one decimal places.

If Liters / h is selected there will be no decimal places in the following screens:

### [Flow Display]

[<EXPANSION>] ~ [SLEEP SET] ~ [Sleep Flow]  
[<EXPANSION>] ~ [RESET FLT] ~ [Lo Flow Level]  
[<EXPANSION>] ~ [SENSORS] ~ [Flow AIN Tx]  
[<EXPANSION>] ~ [FLOW LMT] ~ [Flow Limit]  
[<EXPANSION>] ~ [FLOW LMT] ~ [Flo Lmt Reset]  
[<EXPANSION>] ~ [FLOW COMP] ~ [Known Flow]  
[<EXPANSION>] ~ [FLOW COMP] ~ [Known Flow]

This equates to a maximum measured flow rate of 655.35 liters per second, 6553.5 liters per minute or 65535 liters per hour when an analogue flow meter source is used.

- 3 If CI\_LI59 is selected the amount of decimal places for the above listed screens is based on the following:

If [<EXPANSION>] ~ [SENSORS] ~ [Volume] by [<EXPANSION>] ~ [SENSORS] ~ [Pulses/volume] is less than 0.1 then two decimal places are used.

If [<EXPANSION>] ~ [SENSORS] ~ [Volume] by [<EXPANSION>] ~ [SENSORS] ~ [Pulses/volume] is less than or equal to 1, one decimal place is used, otherwise no decimal places are used.

Therefore a pulse flow transducer with 20 pulses per liter will cause two decimal places, a pulse flow transducer with 5 pulses per liter will cause one decimal place and a pulse flow transducer with 1 pulse per 10 liters will cause no decimal places.

## [Flow AIN Tx] : (Flow Transducer Analogue Input Maximum)

Default	0.00
Minimum	0.00
Maximum	65535
Unit	%, l/s, l/m, l/h
Modbus Address	%mw392

This screen is used to inform the system of the range of the transducer being used to measure Flow if an analogue transducer is used. This screen is redundant if CI\_LI59 or [NONE] was selected in screen [<EXPANSION>] ~ [SENSORS] ~ [Flow Source].

It is always assumed that the minimum is zero i.e., a 0-10 bar transducer would be selected rather than a 2-10 bar device. If the transducer used is a 0-20 mA and 0-10000 Liters/s device then 10000 should be entered in this screen.

Please note that if one of the Water Solution analogue inputs is used for Inlet / suction pressure then it must be correctly configured in screens [<EXPANSION>] ~ [CONFIG] ~ [CI\_AI51 Type] or [<EXPANSION>] ~ [CONFIG] ~ [CI\_AI52 Type] respectively.

# Parameter Descriptions

## [Pulses/volume] : (Pulses per volume)

Default	1.00
Minimum	0.1
Maximum	655.35
Unit	p/v
Modbus Address	%mw394

If a pulse flow transducer is used this screen sets the amount of pulses expected per volume set in screen [[<EXPANSION>](#)] ~ [[SENSORS](#)] ~ [[Volume](#)]. See also [[<EXPANSION>](#)] ~ [[SENSORS](#)] ~ [[Flow Source](#)] for a description of scaling effects.

## [Volume] : (Volume)

Default	1
Minimum	1
Maximum	65535
Unit	l
Modbus Address	%mw396

If a pulse flow transducer is used this screen sets the volume expected per pulse quantity set in screen [[<EXPANSION>](#)] ~ [[SENSORS](#)] ~ [[Pulses/volume](#)]. See also [[<EXPANSION>](#)] ~ [[SENSORS](#)] ~ [[Flow Source](#)] for a description of scaling effects.

## [Flow Units] : (Flow Units)

Default	Liters/s
Range	%, Liters/s, Liters/m, Liters/h
Modbus Address	%mw398

This screen sets the unit displayed for all other screens that display or allow modification of a flow rate. See also [[<EXPANSION>](#)] ~ [[SENSORS](#)] ~ [[Flow Source](#)] for a description of scaling effects.

Please note that if other unit than volume is selected, it will switch back to a volume unit.

## [Flow Filter] : (Flow Filter)

Default	0
Minimum	0
Maximum	65535
Unit	sec
Modbus Address	%mw400

If a pulse flow transducer is used this screen sets the filter time base. If the signal is of a reasonably high frequency some instability may be present. This filter is used to dampen the rate of change of the derived flow rate.

## WARNING

### RISK OF UNINTENDED EQUIPMENT OPERATION

If the value entered is too high, long delays may be present between a change of flow and any desired evasive action taking place.

**Failure to follow this instruction can result in death, serious injury, or equipment damage.**

# Parameter Descriptions

---

## [Temp Tx Min] : (Temperature Transducer Minimum)

Default	0
Minimum	-32767
Maximum	0
Unit	degrees
Modbus Address	%mw402

This screen is used to inform the system of the range of the transducer being used to measure temperature. If the transducer used is a 4-20 mA and -10 to +100 °C device then -10 should be entered in this screen.

Please note that if one of the Water Solution analogue inputs is used for temperature, it must be correctly configured in screens [\[<EXPANSION>\]](#) ~ [\[CONFIG\]](#) ~ [\[CI\\_AI51 Type\]](#) or [\[<EXPANSION>\]](#) ~ [\[CONFIG\]](#) ~ [\[CI\\_AI52 Type\]](#) respectively.

## [Temp Tx Max] : (Temperature Transducer Maximum)

Default	100
Minimum	0
Maximum	32767
Unit	degrees
Modbus Address	%mw404

This screen is used to inform the system of the range of the transducer being used to measure temperature. If the transducer used is a 4-20 mA and -10 to +100 °C device then +100 should be entered in this screen.

Please note that if one of the Water Solution analogue inputs is used for temperature, it must be correctly configured in screens [\[<EXPANSION>\]](#) ~ [\[CONFIG\]](#) ~ [\[CI\\_AI51 Type\]](#) or [\[<EXPANSION>\]](#) ~ [\[CONFIG\]](#) ~ [\[CI\\_AI52 Type\]](#) respectively.

# Parameter Descriptions

---

## [1.14 - WATER SOLUT.] ~ [<EXPANSION>] ~ [FLOW LMT] ~

### [Activate Lim] : (Activate Limit)

Default	[Disable]
Range	[Disable] or [Enable]
Modbus Address	%mw406

This parameter enables or disables the flow limit function of the Water Solution card.

If flow limiting is enabled and the measured flow increases to a level greater than [<EXPANSION>] ~ [FLOW LIMIT] ~ [Flow Limit] the controller immediately ceases PID control and begins to decelerate the motor at the flow limit rate set in screen [<EXPANSION>] ~ [FLOW LIMIT] ~ [Flow Lmt Ramp]. The motor will continue to decelerate until such time as the measured flow is below [Flow Limit]. At this time the current motor speed is maintained. The system will remain in flow limit until such time as the measured flow is less than [<EXPANSION>] ~ [FLOW LIMIT] ~ [Flow Lmt Reset] when the system again reverts to PID control.

[See figure 13, page 46](#)

### [Flow Limit] : (Flow Limit)

Default	0.0
Minimum	[Flo Lmt Reset]
Maximum	32767
Unit	%, l/s, l/m, l/h
Modbus Address	%mw408

If the flow limit function is enabled flow limiting action is initiated when the measured flow increases to a level greater than that entered in this screen.

[See figure 13, page 46](#)

### [Flo Lmt Reset] : (Flow Limit Reset)

Default	0.0
Minimum	0.0
Maximum	[Flow Limit]
Unit	%, l/s, l/m, l/h
Modbus Address	%mw410

If the flow limit function is enabled flow limiting action is terminated when the measured flow decreases to a level less than that entered in this screen.

[See figure 13, page 46](#)

### [Flow Lmt Ramp] : (Flow Limit Ramp)

Default	10.0
Minimum	0.0
Maximum	999.9
Unit	sec
Modbus Address	%mw412

If the flow limit function is enabled this is the rate at which the motor will be decelerated when the measured flow is above [Flow Lmt]

[See figure 13, page 46](#)

# Parameter Descriptions

## Flow Limit

The following diagram describes the Flow Limit

Figure 13

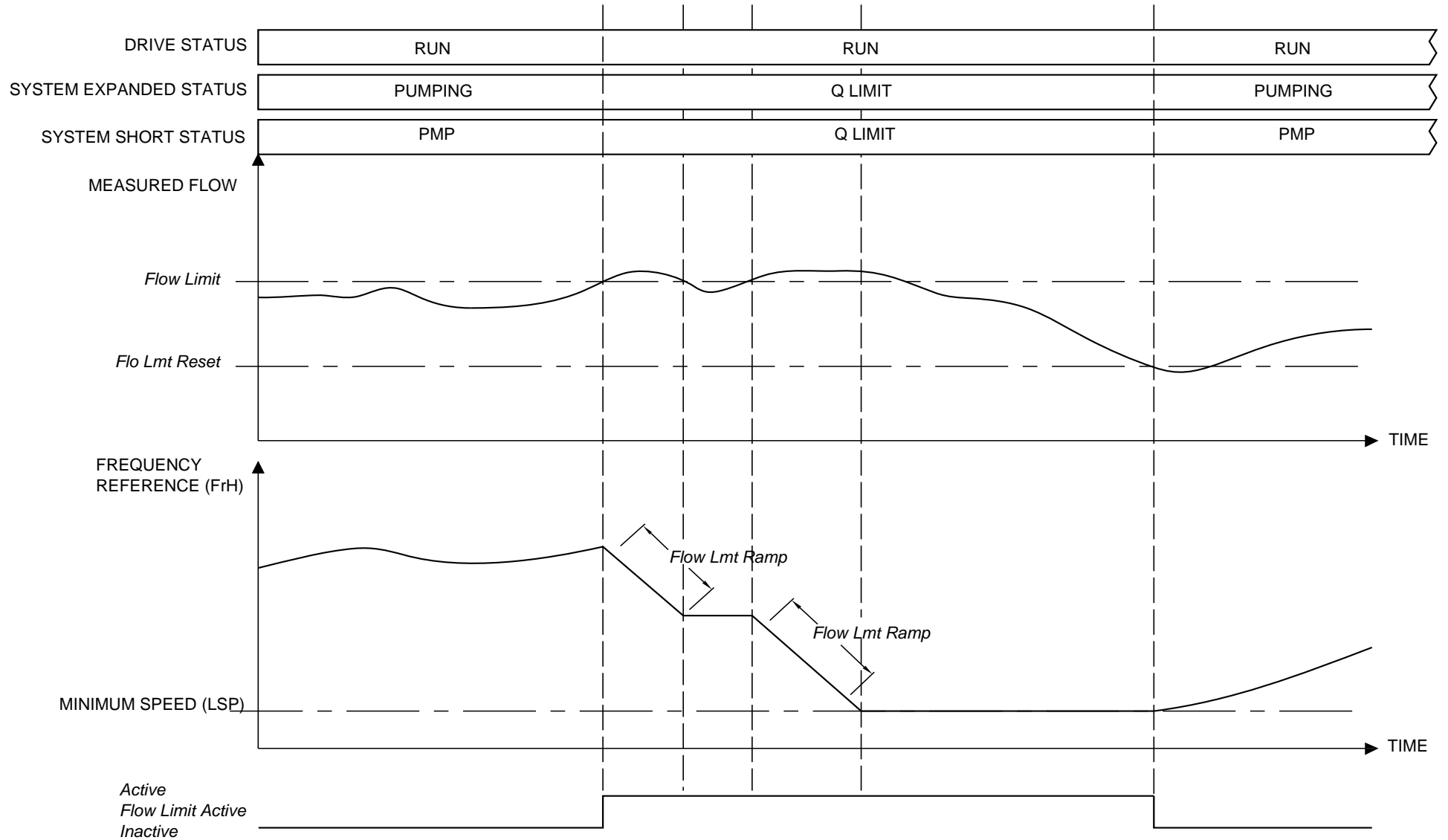

# Parameter Descriptions

---

## [1.14 - WATER SOLUT.] ~ [<EXPANSION>] ~ [PID] ~

### [PID Reference] : (PID Reference)

Default	Local
Range	DRIVE_AI1, DRIVE_AI2, DRIVE_AI3, DRIVE_AI4, CI_AI1, CI_AI2 or LOCAL
Modbus Address	%mw414

This parameter is used to select the reference for the Water Solution PID.

Please note that if one of the Water Solution analogue inputs is used for PID Reference, it must be correctly configured in screens [<EXPANSION>] ~ [CONFIG] ~ [CI\_AI51 Type] or [<EXPANSION>] ~ [CONFIG] ~ [CI\_AI52 Type] respectively.

[See figure 14, page 50](#)

### [PID Max Ref] : (PID Maximum Reference)

Default	3200.0
Minimum	0.0
Maximum	3276.7
Unit	%, kPa, bar, psi
Modbus Address	%mw416

This parameter sets the maximum setpoint that can ever be applied to the Water Solution PID. This can be used to prevent inadvertent operator error during adjustment of the PID setpoint. It can also be useful to limit the effects of flow compensation adjustments.

[See figure 14, page 50](#)

### [PID Feedback] : (PID Feedback)

Default	DRIVE_AI2
Range	DRIVE_AI1, DRIVE_AI2, DRIVE_AI3, DRIVE_AI4, CI_AI1, or CI_AI2
Modbus Address	%mw418

This parameter is used to select the Feedback for the Water Solution PID.

Please note that if one of the Water Solution analogue inputs is used for PID Feedback, it must be correctly configured in screens [<EXPANSION>] ~ [CONFIG] ~ [CI\_AI51 Type] or [<EXPANSION>] ~ [CONFIG] ~ [CI\_AI52 Type] respectively.

[See figure 14, page 50](#)

### [PID Gain] : (PID Gain)

Default	+1.40
Minimum	-100.00
Maximum	+100.00
Unit	x
Modbus Address	%mw420

This parameter sets proportional gain of the custom PID controller.

[See figure 14, page 50](#)

### [PID Integral] : (PID Integral)

Default	10.00
Minimum	0.00
Maximum	100.00
Unit	sec
Modbus Address	%mw422

This parameter sets integral gain of the custom PID controller. [See figure 14, page 50](#)

# Parameter Descriptions

---

## [PID Deriv] : (PID Derivative)

Default	0.00
Minimum	0.00
Maximum	100.00
Unit	sec
Modbus Address	%mw424

This parameter sets derivative gain of the custom PID controller.

[See figure 14, page 50](#)

## [PID Accel] : (PID Acceleration)

Default	5.0
Minimum	0.0
Maximum	999.9
Unit	sec
Modbus Address	%mw426

This parameter sets the minimum time required for the PID controller to accelerate the motor from zero speed to motor rated frequency (FrS) when in PID control. This rate is used whenever the actual motor speed (rFr) is above the motor low speed (LSP) and PID control is active, i.e., not flow limiting, no fault conditions and not stopping.

[See figure 14, page 50](#)

## [PID Decel] : (PID Deceleration)

Default	5.0
Minimum	0.0
Maximum	999.9
Unit	sec
Modbus Address	%mw428

This parameter sets the minimum time required for the PID controller to decelerate the motor from motor rated frequency (FrS) to zero speed when in PID control. This rate is used whenever the actual motor speed (rFr) is above the motor low speed (LSP) and PID control is active, i.e., not flow limiting and no fault conditions.

[See figure 14, page 50](#)

## [Strt Acc Rate] : (Starting Acceleration Rate)

Default	3.0
Minimum	0.0
Maximum	999.9
Unit	sec
Modbus Address	%mw430

This parameter sets the time required for the system to accelerate the motor from zero speed to motor rated frequency (FrS). This rate is used whenever the actual motor speed (rFr) is below the motor low speed (LSP) setting and no fault conditions are present.

[See figure 14, page 50](#)

# Parameter Descriptions

---

## **[Stp Dec Rate] : (Stopping Deceleration Rate)**

Default	3.0
Minimum	0.0
Maximum	999.9
Unit	sec
Modbus Address	%mw432

This parameter sets the time required for the system to decelerate from motor rated frequency (FrS) to zero speed. This rate is used whenever a stop command is present. [See figure 14, page 50](#)

## **[Alt Reference] : (Alternative Reference)**

Default	Local
Range	DRIVE_AI1, DRIVE_AI2, DRIVE_AI3, DRIVE_AI4, CI_AI1, CI_AI2 or LOCAL
Modbus Address	%mw434

This parameter is used to select the alternative reference for the Water Solution PID. This reference becomes active when drive digital input two (DRIVE\_LI2) is active.

Please note that if one of the Water Solution card analogue inputs is used for PID Reference, it must be correctly configured in screens [\[<EXPANSION>\] ~ \[CONFIG\] ~ \[CI\\_AI51 Type\]](#) or [\[<EXPANSION>\] ~ \[CONFIG\] ~ \[CI\\_AI52 Type\]](#) respectively.

[See figure 14, page 50](#)

# Parameter Descriptions

## PID Schematic

The following diagram describes the PID Schematic

Figure 14

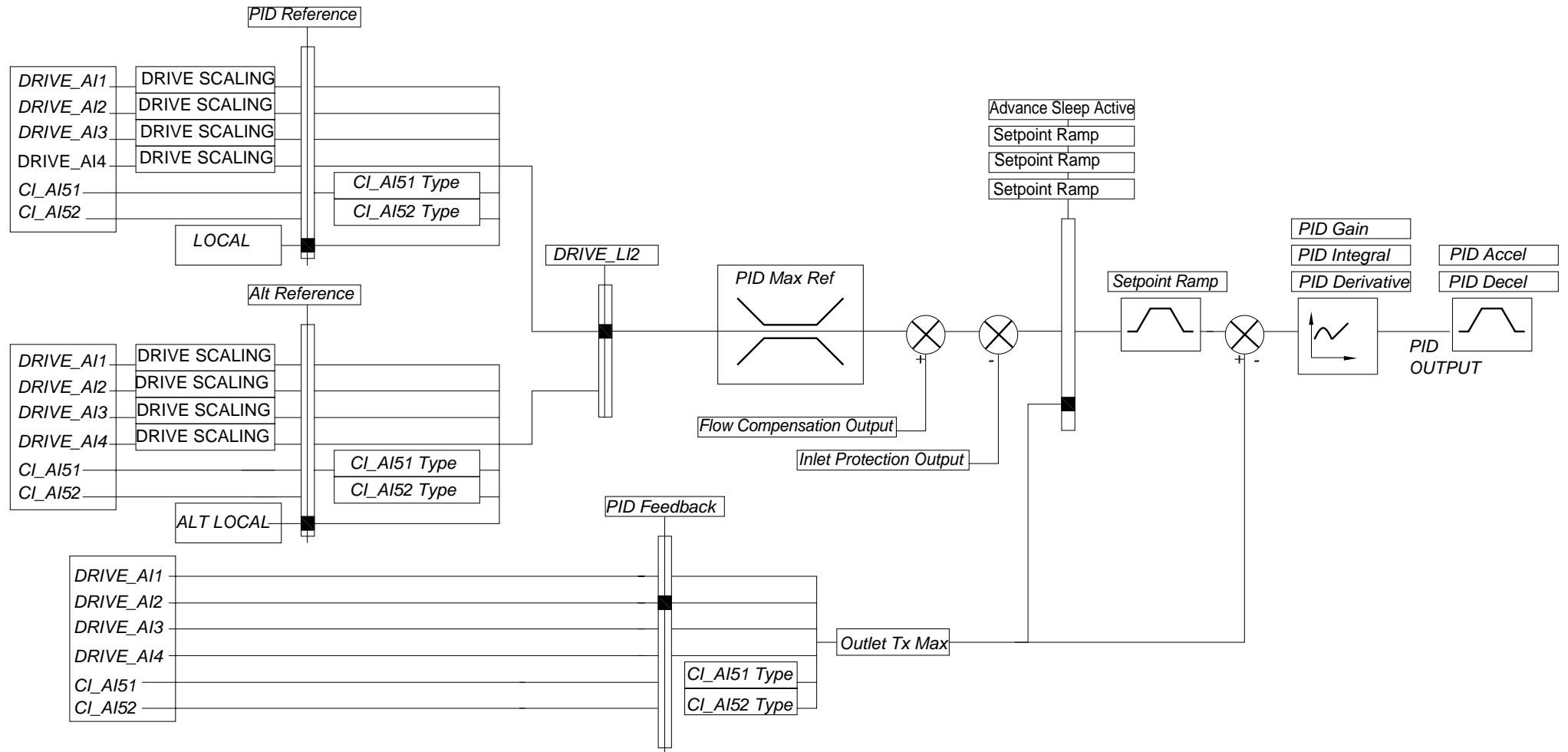

# Parameter Descriptions

## [1.14 - WATER SOLUT.] ~ [<EXPANSION>] ~ [STAGE] ~

### [Number of EXT] : (Number of External Pumps)

Default	0
Minimum	0
Maximum	3
Unit	pmp
Modbus Address	%mw436

This parameter sets the number of auxiliary pumps that are installed.

### [Duty Sharing] : (Duty Sharing)

Default	Enable
Range	[ON] or [OFF]
Modbus Address	%mw438

If duty sharing is enabled and an auxiliary pump is required, the pump with the least amount of run hours will always be started first. If an auxiliary pump is required to be destaged, the pump with the biggest amount of run hours will always be stopped first. If duty sharing is disabled the pumps will be started and stopped numerically, i.e., 1 on then 2 on then 3 on, 3 off then 2 off then 1 off

Parameter set [<EXPANSION>] ~ [SAVED TIM] ~ shows the saved run time hours for all pumps.

### [Stage Mode] : (Stage Mode)

Default	Sp+Pr+Dly
Range	Sp+Pr+Dly, Sp+Pr, Sp+Dly, Sp Only, Pr+Dly, Pr Only
Modbus Address	%mw440

This parameter sets the permissives that will be needed before an auxiliary pump is started.

Sp+Pr+Dly	If this is selected an auxiliary pump will not be staged until the Variable speed pump is greater than [<EXPANSION>] ~ [STAGE] ~ [Stage Speed], the system error (setpoint - feedback) is greater than [<EXPANSION>] ~ [STAGE] ~ [Stage Error] and these two permissive have been true for longer than [<EXPANSION>] ~ [STAGE] ~ [Stage Delay].
Sp+Pr	If this is selected an auxiliary pump will not be staged until the Variable speed pump is greater than [<EXPANSION>] ~ [STAGE] ~ [Stage Speed] and the system error (setpoint - feedback) is greater than [<EXPANSION>] ~ [STAGE] ~ [Stage Error].
Sp+Dly	If this is selected an auxiliary pump will not be staged until the Variable speed pump is greater than [<EXPANSION>] ~ [STAGE] ~ [Stage Speed] for longer than [<EXPANSION>] ~ [STAGE] ~ [Stage Delay].
Sp Only	If this is selected an auxiliary pump will not be staged until the Variable speed pump is greater than [<EXPANSION>] ~ [STAGE] ~ [Stage Speed].
Pr+Dly	If this is selected an auxiliary pump will not be staged until the system error (setpoint - feedback) is greater than [<EXPANSION>] ~ [STAGE] ~ [Stage Error] for longer than [<EXPANSION>] ~ [STAGE] ~ [Stage Delay].
Pr Only	If this is selected an auxiliary pump will not be staged until the system error (setpoint - feedback) is greater than [<EXPANSION>] ~ [STAGE] ~ [Stage Error].

[See figure 15, page 54](#)

### [Stage Speed] : (Stage Speed)

Default	50
Minimum	[Stage Byp Spd]
Maximum	HSP
Unit	Hz
Modbus Address	%mw442

This parameter sets the minimum speed of the Variable speed pump before an auxiliary pump is started if [Speed] is one of the stage permissives selected in screen [<EXPANSION>] ~ [STAGE] ~ [Stage Mode].

[See figure 15, page 54](#)

# Parameter Descriptions

---

## [Stage Error] : (Stage Error)

Default	0.0
Minimum	0.0
Maximum	3276.7
Unit	%, kPa, bar, psi
Modbus Address	%mw444

This parameter sets the required system error (setpoint - feedback) before an auxiliary pump is started if **[Error]** is one of the stage permissives selected in screen **[<EXPANSION>] ~ [STAGE] ~ [Stage Mode]**.

[See figure 15, page 54](#)

## [Stage Delay] : (Stage Delay)

Default	5
Minimum	0
Maximum	3600
Unit	sec
Modbus Address	%mw446

This parameter sets the required delay after a selected permissive has been met before an auxiliary pump is started if delay is one of the stage permissives selected in screen **[<EXPANSION>] ~ [STAGE] ~ [Stage Mode]**.

[See figure 15, page 54](#)

## [Stage Byp Spd] : (Stage Bypass Speed)

Default	50
Minimum	LSP
Maximum	Stage Speed
Unit	Hz
Modbus Address	%mw448

Immediately prior to staging an auxiliary pump, the Variable speed pump will decelerate to the speed entered in this screen and will remain at this speed for the time entered in screen **[<EXPANSION>] ~ [STAGE] ~ [Stg Byp Time]**. After this time the system reverts back to PID control.

[See figure 15, page 54](#)

## [Stg Byp Time] : (Stage Bypass Time)

Default	5
Minimum	0
Maximum	3600
Unit	sec
Modbus Address	%mw450

Immediately prior to staging an auxiliary pump, the Variable speed pump will decelerate to the speed entered in screen **[<EXPANSION>] ~ [STAGE] ~ [Stage Byp Spd]** and will remain at this speed for the time entered in this screen. After this time the system reverts back to PID control.

[See figure 15, page 54](#)

# Parameter Descriptions

---

## **[Stage Offset] : (Stage Offset)**

Default	0
Minimum	0
Maximum	<b>[Stage Speed] - [Stage Byp Spd]</b>
Unit	Hz
Modbus Address	%mw452

Immediately prior to staging an auxiliary pump the Variable speed pump will decelerate to the speed entered in screen **[<EXPANSION>] ~ [STAGE] ~ [Stage Byp Spd]**. On commencement of deceleration the auxiliary pump is not necessarily staged immediately. If desired the system can wait until the Variable speed pump has slowed to **[Stage Byp Spd]** + the value entered in this screen. This setting is typically used when the external pumps are soft starter controlled.

[See figure 15, page 54](#)

# Parameter Descriptions

## Stage

The following diagram describes the Stage

Figure 15

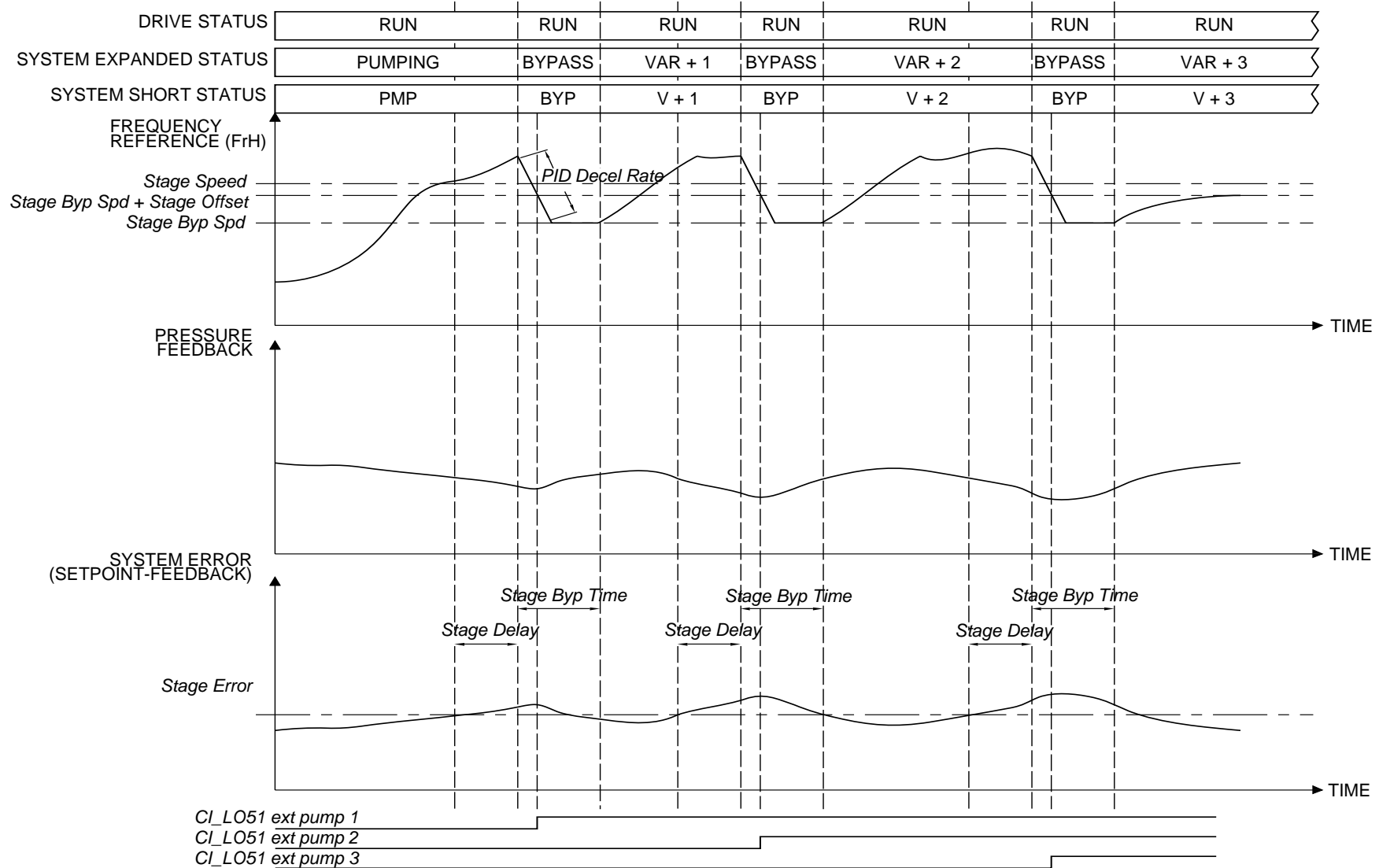

# Parameter Descriptions

## [1.14 - WATER SOLUT.] ~ [<EXPANSION>] ~ [DESTAGE] ~

### [Destage Mode] : (Destage Mode)

Default	Sp+Pr+Dly
Range	Sp+Pr+Dly, Sp+Pr, Sp+Dly, Sp Only, Pr+Dly, Pr Only
Modbus Address	%mw454

This parameter sets the permissives that will be needed before an auxiliary pump is stopped.

Sp+Pr+Dly	If this is selected an auxiliary pump will not be destaged until the Variable speed pump is less than [<EXPANSION>] ~ [DESTAGE] ~ [Destage Speed], the system error (setpoint - feedback) is less than [<EXPANSION>] ~ [DESTAGE] ~ [Destage Error] and these two permissive have been true for longer than [<EXPANSION>] ~ [DESTAGE] ~ [Destage Delay].
Sp+Pr	If this is selected an auxiliary pump will not be destaged until the Variable speed pump is less than [<EXPANSION>] ~ [DESTAGE] ~ [Destage Speed] and the system error (setpoint - feedback) is less than [<EXPANSION>] ~ [DESTAGE] ~ [Destage Error].
Sp+Dly	If this is selected an auxiliary pump will not be destaged until the Variable speed pump is less than [<EXPANSION>] ~ [DESTAGE] ~ [Destage Speed] for longer than [<EXPANSION>] ~ [DESTAGE] ~ [Destage Delay].
Sp Only	If this is selected an auxiliary pump will not be destaged until the Variable speed pump is less than [<EXPANSION>] ~ [DESTAGE] ~ [Destage Speed].
Pr+Dly	If this is selected an auxiliary pump will not be destaged until the system error (setpoint - feedback) is less than [<EXPANSION>] ~ [DESTAGE] ~ [Destage Error] for longer than [<EXPANSION>] ~ [DESTAGE] ~ [Destage Delay].
Pr Only	If this is selected an auxiliary pump will not be destaged until the system error (setpoint - feedback) is less than [<EXPANSION>] ~ [DESTAGE] ~ [Destage Error].

[See figure 16, page 57](#)

### [Destage Speed] : (Destage Speed)

Default	40
Minimum	LSP
Maximum	[Dstge Byp Sp]
Unit	Hz
Modbus Address	%mw456

This parameter sets the speed of the Variable speed pump before an auxiliary pump is stopped if [Speed] is one of the destage permissives selected in screen [<EXPANSION>] ~ [DESTAGE] ~ [Destage Mode].

[See figure 16, page 57](#)

### [Destage Error] : (Destage Error)

Default	0.0
Minimum	-3276.7
Maximum	0
Unit	%, kPa, bar, psi
Modbus Address	%mw458

This parameter sets the required system error (setpoint - feedback) before an auxiliary pump is stopped if [Error] is one of the destage permissives selected in screen [<EXPANSION>] ~ [DESTAGE] ~ [Destage Mode].

[See figure 16, page 57](#)

### [Destage Delay] : (Destage Delay)

Default	1
Minimum	0
Maximum	3600
Unit	sec
Modbus Address	%mw460

This parameter sets the required delay, after selected permissives have been met, before an auxiliary pump is stopped if delay is one of the destage permissives selected in screen [<EXPANSION>] ~ [DESTAGE] ~ [Destage Mode]. [See figure 16, page 57](#)

# Parameter Descriptions

---

## **[Dstge Byp Sp] : (Destage Bypass Speed)**

Default	40
Minimum	<a href="#">[Destage Speed]</a>
Maximum	HSP
Unit	Hz
Modbus Address	%mw462

Immediately prior to destaging an auxiliary pump, the Variable speed pump will accelerate to the speed entered in this screen and will remain at this speed for the time entered in screen [\[<EXPANSION>\]](#) ~ [\[DESTAGE\]](#) ~ [\[Dstg Byp Time\]](#). After this time the system reverts back to PID control.

[See figure 16, page 57](#)

## **[Dstg Byp Time] : (Destage Bypass Time)**

Default	5
Minimum	0
Maximum	3600
Unit	sec
Modbus Address	%mw464

Immediately prior to destaging an auxiliary pump, the Variable speed pump will accelerate to the speed entered in screen [\[<EXPANSION>\]](#) ~ [\[DESTAGE\]](#) ~ [\[Dstge Byp Sp\]](#) and will remain at this speed for the duration entered in this screen. After this time the system reverts back to PID control.

[See figure 16, page 57](#)

## **[Dstg Offset] : (Destage Offset)**

Default	0
Minimum	0
Maximum	250
Unit	Hz
Modbus Address	%mw466

Immediately prior to destaging an auxiliary pump, the Variable speed pump will accelerate to the speed entered in screen [\[<EXPANSION>\]](#) ~ [\[DESTAGE\]](#) ~ [\[Dstge Byp Sp\]](#). On commencement of acceleration the auxiliary pump is not necessarily destaged immediately. If desired the system can wait until the Variable speed pump has risen to [\[Dstge Byp Sp\]](#) (the value entered in this screen).

[See figure 16, page 57](#)

# Parameter Descriptions

## Destage

the following diagram describes the Destage

Figure 16

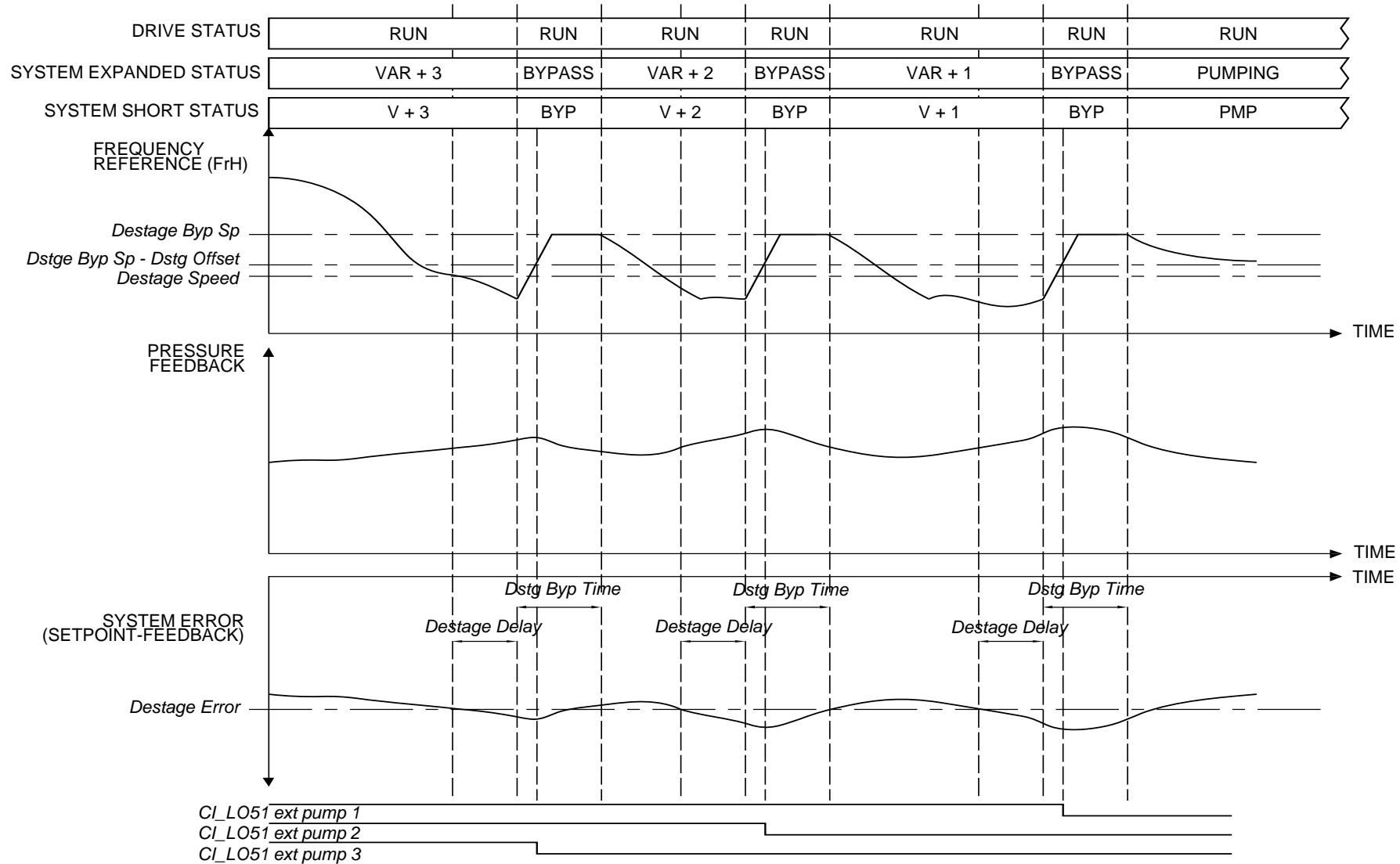

# Parameter Descriptions

---

## [1.14 - WATER SOLUT.] ~ [<EXPANSION>] ~ [JOCKEY] ~

### [Jockey] : (Jockey)

Default	[Disable]
Range	[Disable] or [Enable]
Modbus Address	%mw468

This parameter enables or disables the Jockey function of the Water Solution card.

The Jockey function requires a pump to be controlled via digital output CI\_LO56. The Jockey pump / function, maintains the setpoint pressure during times of low demand.

[See figure 17, page 59](#)

### [Jky Stop P] : (Jockey Stop Pressure)

Default	0
Minimum	[Jky On Press]
Maximum	3276.7
Unit	%, kPa, bar, psi
Modbus Address	%mw470

If the Jockey function is enabled, digital output relay CI\_LO56 will switch on when the measured pressure falls below the value set in screen [<EXPANSION>] ~ [JOCKEY] ~ [Jky Start P] for longer than the time entered in screen [<EXPANSION>] ~ [JOCKEY] ~ [Jky On Delay]. The Jockey pump will remain on until the pressure rises above the value entered in this screen or until the Variable speed pump starts due to a higher demand than that which the Jockey pump can meet.

[See figure 17, page 59](#)

### [Jky Start P] : (Jockey Start Pressure)

Default	0
Minimum	0
Maximum	[Jky Off Press]
Unit	%, kPa, bar, psi
Modbus Address	%mw472

If the Jockey function is enabled, digital output relay CI\_LO56 will switch on when the measured pressure falls below the value entered in this screen for longer than the time entered in screen [<EXPANSION>] ~ [JOCKEY] ~ [Jky On Delay]. The jockey pump will remain on until the pressure rises above the value entered in screen [<EXPANSION>] ~ [JOCKEY] ~ [Jky Stop P] or until the variable speed pump starts due to a higher demand than that which the Jockey pump can meet.

[See figure 17, page 59](#)

### [Jky On Delay] : (Jockey On Delay)

Default	0
Minimum	0
Maximum	3600
Unit	sec
Modbus Address	%mw474

If the Jockey function is enabled, digital output relay CI\_LO56 will switch on when the measured pressure falls below the value entered in screen [<EXPANSION>] ~ [JOCKEY] ~ [Jky Start P] for longer than the time entered in this screen. The jockey pump will remain on until the pressure rises above the value entered in screen [<EXPANSION>] ~ [JOCKEY] ~ [Jky Stop P] or until the Variable speed pump starts due to a higher demand than that which the Jockey pump can meet.

[See figure 17, page 59](#)

# Parameter Descriptions

## Jockey

The following diagram describes the Jockey

Figure 17

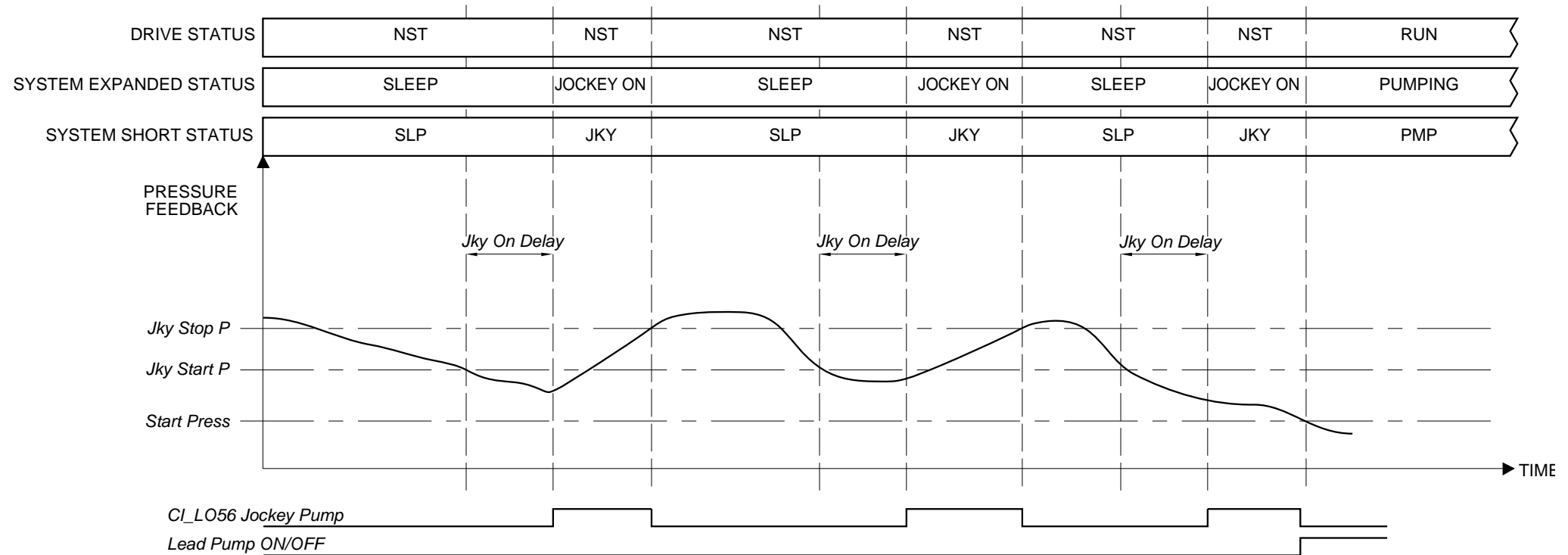

# Parameter Descriptions

---

## [1.14 - WATER SOLUT.] ~ [<EXPANSION>] ~ [RUN TIMES] ~

### [Timed Pumping] : (Timed Pumping)

Default	[Disable]
Range	[Disable] or [Enable]
Modbus Address	%mw476

This parameter enables or disables the [Run Times] function of the Water solution card.

If enabled the system will only run during the times set in the following screens. If disabled the system will run whenever start permissives are met. If the following values are entered in the following screens:

[<EXPANSION>] ~ [RUN TIMES] ~ [Start Hours]	=	19
[<EXPANSION>] ~ [RUN TIMES] ~ [Start Mins]	=	0
[<EXPANSION>] ~ [RUN TIMES] ~ [Stop Hours]	=	8
[<EXPANSION>] ~ [RUN TIMES] ~ [Stop Mins]	=	0

The system will only run between 19:00 hours (7pm) and 08:00 hours (8am). At all other times the system will be off.

[See figure 18, page 62](#)

### [Start Hours] : (Start Hours)

Default	0
Minimum	0
Maximum	23
Unit	Hrs
Modbus Address	%mw478

This screen sets the start hours.

[See figure 18, page 62](#)

### [Start Mins] : (Start Minutes)

Default	0
Minimum	0
Maximum	59
Unit	Min
Modbus Address	%mw480

This screen sets the start minutes.

[See figure 18, page 62](#)

### [Stop Hours] : (Stop Hours)

Default	0
Minimum	0
Maximum	23
Unit	Hrs
Modbus Address	%mw482

This screen sets the stop hours.

[See figure 18, page 62](#)

# Parameter Descriptions

---

## [Stop Mins] : (Stop Minutes)

Default	0
Minimum	0
Maximum	59
Unit	Min
Modbus Address	%mw484

This screen sets the stop minutes.

[See figure 18, page 62](#)

# Parameter Descriptions

## Run Times

The following diagram describes the Run Times

Figure 18

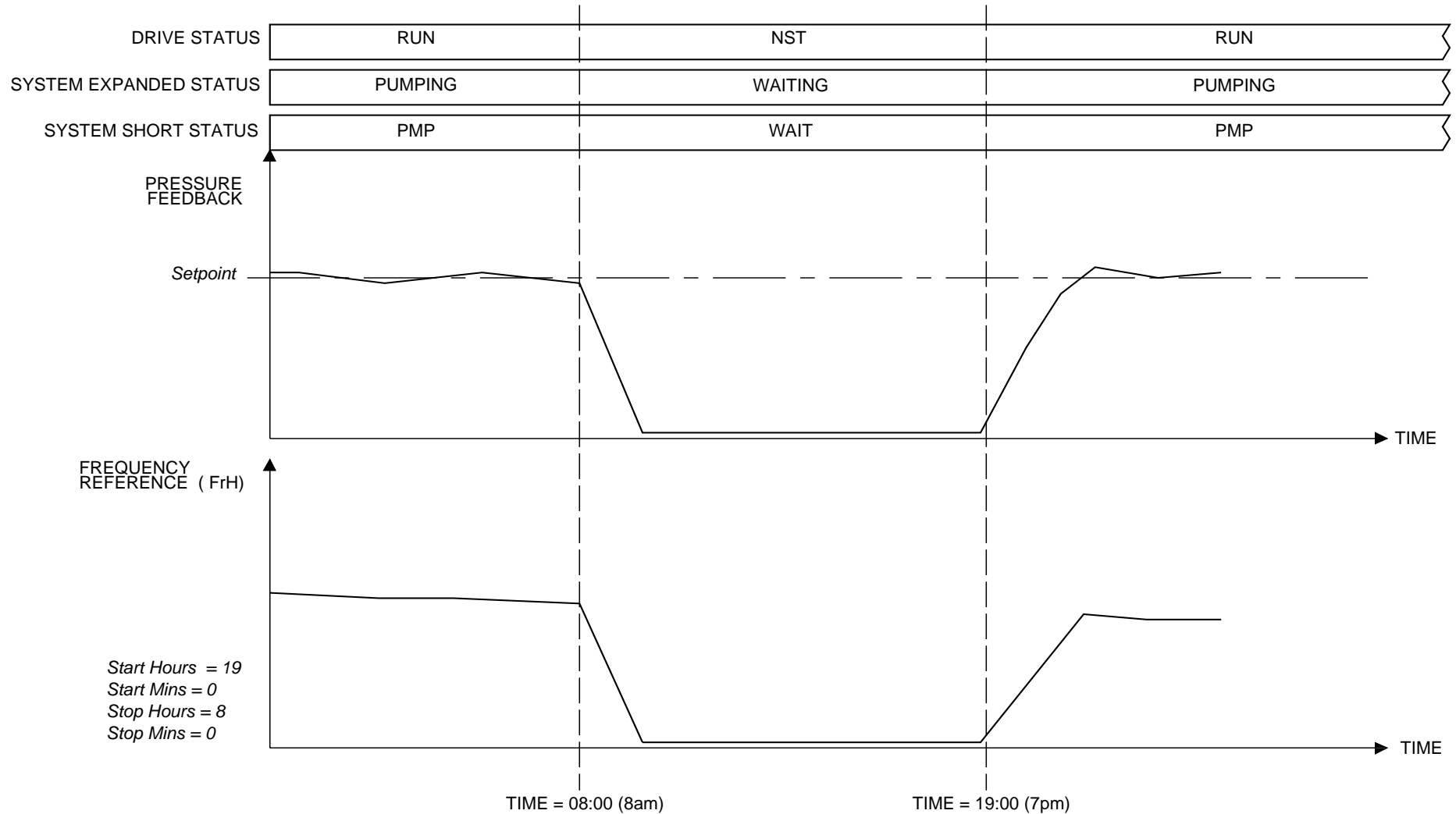

# Parameter Descriptions

## [1.14 - WATER SOLUT.] ~ [<EXPANSION>] ~ [NIGHT&DAY] ~

### [Night & Day] : (Night And Day)

Default	[Enable]
Range	[Enable] or [Disable]
Modbus Address	%mw486

This parameter enables or disables the Night and Day function of the Water Solution card.

If enabled, the system will enter Night and Day during the times set in the following screens. If the following values are entered in the following screens:

[<EXPANSION>] ~ [NIGHT&DAY] ~ [Start Hours]	=	19
[<EXPANSION>] ~ [NIGHT&DAY] ~ [Start Mins]	=	0
[<EXPANSION>] ~ [NIGHT&DAY] ~ [Stop Hours]	=	8
[<EXPANSION>] ~ [NIGHT&DAY] ~ [Stop Mins]	=	0

the system will enter Night and Day between 19:00 hours (7pm) and 08:00 hours (8am). At all other times the system will operate normally. When in Night and Day the system behaves similarly to the Jockey function but uses the Variable speed pump to maintain pressure at times of low demand. The system does this by turning the Variable speed pump on and running it at a fixed speed until the pressure feedback increases.

When in Night and Day the Variable speed pump will start whenever the feedback pressure falls below the value entered in screen [<EXPANSION>] ~ [NIGHT&DAY] ~ [N&D Start P]. The Variable speed pump will run at the speed entered in screen [<EXPANSION>] ~ [NIGHT&DAY] ~ [N&D Speed] until such time as the feedback pressure is greater than entered in screen [<EXPANSION>] ~ [NIGHT&DAY] ~ [N&D Stop P].

There are two scenarios which will cause the system to exit the night and day function:

- 1 After the pump has run for the time entered in screen [<EXPANSION>] ~ [NIGHT&DAY] ~ [Measure Time], the feedback pressure is noted and compared to the start pressure. If the pressure has risen the pump continues to run and a comparison is made periodically (measure time). If at any time the pressure has decreased from the previous value the system will assume a high demand and exit the night and day function. The system will now behave as a standard Variable speed pump.
- 2 If cycling is sensed, the system will assume a high demand and exit the night and day function. The system will now behave as a standard Variable speed pump. Cycling is sensed when (time stopped / (time running + time stopped) \*100) is less than the value entered in screen [<EXPANSION>] ~ [NIGHT&DAY] ~ [Cyclic Ratio]. If a value of 50 is entered as the cyclic ratio the system will sense cycling if the pump is on for longer than it is off (high demand).

Once the system has exited the night and day function the system behaves as a normal system. However the sensed high demand may reduce and the system enters the sleep state. If this happens and the system has been in the sleep state for longer than the time entered in screen [<EXPANSION>] ~ [NIGHT&DAY] ~ [Restart Time] low demand is sensed and the system will re-enter the night and day function as long as it is still within the night and day time permissive.

[See figure 19, page 66](#)

### [Start Hours] : (Start Hours)

Default	0
Minimum	0
Maximum	23
Unit	Hrs
Modbus Address	%mw488

This screen sets the start hours.

[See figure 19, page 66](#)

### [Start Mins] : (Start Minutes)

Default	0
Minimum	0
Maximum	59
Unit	Min
Modbus Address	%mw490

This screen sets the start minutes.

[See figure 19, page 66](#)

# Parameter Descriptions

---

## [Stop Hours] : (Stop Hours)

Default	0
Minimum	0
Maximum	23
Unit	Hrs
Modbus Address	%mw492

This screen sets the stop hours.

[See figure 19, page 66](#)

## [Stop Mins] : (Stop Minutes)

Default	0
Minimum	0
Maximum	59
Unit	Min
Modbus Address	%mw494

This screen sets the stop minutes.

[See figure 19, page 66](#)

## [N&D Start P] : (Start Pressure)

Default	0
Minimum	0
Maximum	<a href="#">[N&amp;D Stop P]</a>
Unit	%, kPa, bar, psi
Modbus Address	%mw496

If the Night and Day function is enabled and active the Variable speed pump will start when the feedback pressure falls below the value entered in this screen. [See figure 19, page 66](#)

## [N&D Stop P] : (Stop Pressure)

Default	0
Minimum	N&D Start P
Maximum	3276.7
Unit	%, kPa, bar, psi
Modbus Address	%mw498

If the night and day function is enabled and active the Variable speed pump will stop when the feedback pressure rises above the value entered in this screen.

[See figure 19, page 66](#)

## [Measure Time] : (Measure Time)

Default	0
Minimum	0
Maximum	32767
Unit	sec
Modbus Address	%mw500

Each time the drive starts when the night and day function is active the feedback pressure is noted. Periodically at the interval set in this screen the feedback is again noted. If the pressure has risen, the system remains in night and day but if the pressure falls, it is assumed the demand is greater than that which the night and day function can supply and the system leaves the night and day function and reverts to normal operation.

[See figure 19, page 66](#)

# Parameter Descriptions

---

## [N&D Speed] : (Night and Day Speed)

Default	0
Minimum	LSP
Maximum	HSP
Unit	Hz
Modbus Address	%mw502

If the night and day function is enabled and active the Variable speed pump will run at the value entered in this screen when the pressure falls below that entered in screen [**<EXPANSION>**] ~ [**NIGHT&DAY**] ~ [**N&D Start P**].

[See figure 19, page 66](#)

## [Cyclic Ratio] : (Cyclic Ratio)

Default	50
Minimum	0
Maximum	32767
Unit	%
Modbus Address	%mw504

If cycling is sensed the system will assume a high demand and exit the Night and Day function. The system will then behave as a standard pumping system. Cycling is sensed when  $(\text{time stopped} / (\text{time running} + \text{time stopped}) * 100)$  is less than the value entered in this screen. If a value of 50 is entered in this screen the system will sense cycling if the pump is on for longer than it is off (high demand).

[See figure 19, page 66](#)

## [Restart Time] : (Restart Time)

Default	90
Minimum	0
Maximum	32767
Unit	sec
Modbus Address	%mw506

Once the system has exited the Night and Day function the system behaves as a normal pump system. However the sensed high demand may reduce and the system enters the sleep state. If this happens and the system has been in the sleep state for longer than the time entered in this screen, low demand is sensed and the system will re-enter the night and day function as long as it is still within the Night and Day time permissive.

[See figure 19, page 66](#)



Please note that the internal clock does not automatically switch to daylight saving time.

# Parameter Descriptions

## Night & Day

The following diagram describes Night & Day

Figure 19

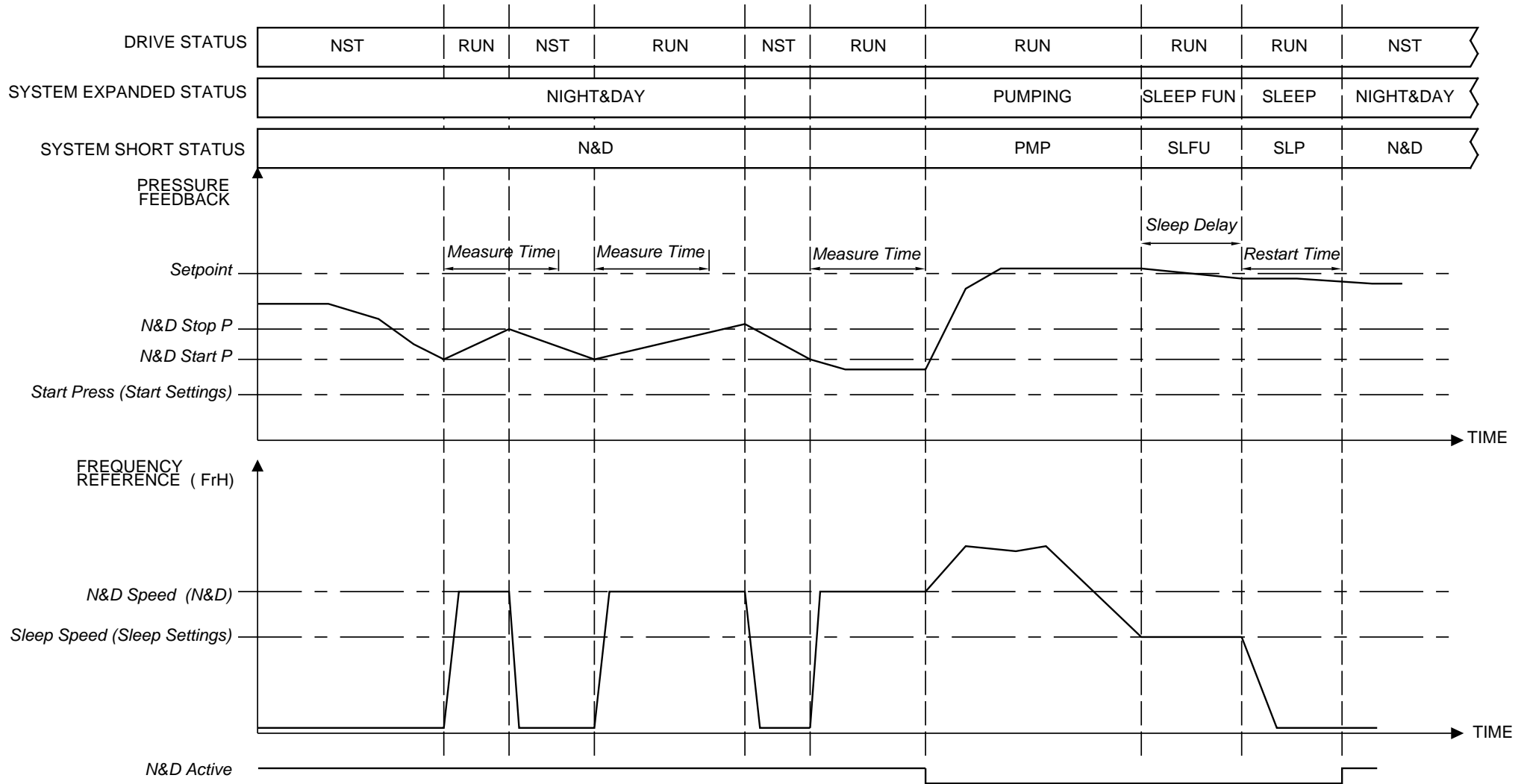

# Parameter Descriptions

---

## [1.14 - WATER SOLUT.] ~ [<EXPANSION>] ~ [FLOW COMP] ~

### [Comp Select] : (Compensation Select)

Default	[None]
Range	[None], [FlowComp] or [FixedComp]
Modbus Address	%mw508

This parameter sets the type of flow compensation the system should use. If none is selected no compensation occurs regardless of the flow or number of external pumps running.

If [FlowComp] is selected, screens [<EXPANSION>] ~ [FLOW COMP] ~ [Known Flow] and [<EXPANSION>] ~ [FLOW COMP] ~ [Press Drop] become relevant. All other screens in this sub-menu become irrelevant. For [FlowComp] to work, a flow meter must be installed and calibrated correctly. The [FlowComp] algorithm uses the Hazen-Williams calculation but requires two measured values to be entered. These are a known flow, preferably near maximum system demand, and the measured pressure drop at the point you wish compensation to correct for at this flow rate. These are entered in screens [<EXPANSION>] ~ [FLOW COMP] ~ [Known Flow] and [<EXPANSION>] ~ [FLOW COMP] ~ [Press Drop] respectively.

[See figure 20, page 69](#)

### [Known Flow] : (Known Flow)

Default	0.00
Minimum	0.00
Maximum	32767
Unit	%, l/s, l/m, l/h
Modbus Address	%mw510

If [FlowComp] is selected as the method of compensation in screen [<EXPANSION>] ~ [FLOW COMP] ~ [Comp Select] then the algorithm requires a measured flow rate and the measured pressure drop at the point compensation is correcting for.

[See figure 20, page 69](#)

### [Press Drop] : (Pressure Drop)

Default	0.0
Minimum	0.0
Maximum	3276.7
Unit	%, kPa, bar, psi
Modbus Address	%mw512

If [FlowComp] is selected as the method of compensation in screen [<EXPANSION>] ~ [FLOW COMP] ~ [Comp Select] then the algorithm requires a measured flow rate and the measured pressure drop at the point compensation is correcting for.

[See figure 20, page 69](#)

### [Var Comp] : (Variable Speed Pump Compensation)

Default	0.00
Minimum	0.00
Maximum	327.67
Unit	%, kPa, bar, psi
Modbus Address	%mw514

If [FixedComp] is selected as the method of compensation in screen [<EXPANSION>] ~ [FLOW COMP] ~ [Comp Select] the system will compensate for flow based firstly on Variable speed pump and then on the number of external pumps that are running. The value entered in this screen is added to the applied setpoint linearly from minimum speed (LSP) to maximum speed (HSP). I.e, if the following values are entered:

LSP = 30 Hz

HSP = 50 Hz

Var Comp = 1 bar

At 30 Hz no compensation is made, at 40 Hz, 0.5 bar is added to the applied setpoint and at 50 Hz 1.0 bar is added to the applied setpoint.

[See figure 21, page 70](#)

# Parameter Descriptions

---

## [Ext 1 Comp] : (Fixed one Compensation)

Default	0.00
Minimum	0.00
Maximum	327.67
Unit	%, kPa, bar, psi
Modbus Address	%mw516

If **[FixedComp]** is selected as the method of compensation in screen **[<EXPANSION>** ~ **[FLOW COMP]** ~ **[Comp Select]** the system will compensate for flow based firstly on Variable speed pump and then on the number of external pumps that are running. The value entered in this screen is added to the applied setpoint when one external pump is required to run. The total compensation would be:

$$(\text{Var Comp} * ((\text{Actual Speed-LSP}) / (\text{HSP-LSP}))) + \text{Fixed1 Comp}$$

[See figure 21, page 70](#)

## [Ext 2 Comp] : (Fixed two Compensation)

Default	0.00
Minimum	0.00
Maximum	327.67
Unit	%, kPa, bar, psi
Modbus Address	%mw518

If **[FixedComp]** is selected as the method of compensation in screen **[<EXPANSION>** ~ **[FLOW COMP]** ~ **[Comp Select]** the system will compensate for flow based firstly on Variable speed pump and then on the number of external pumps that are running. The value entered in this screen is added to the applied setpoint when two external pumps are required to run. The total compensation would be:

$$(\text{Var Comp} * ((\text{Actual Speed-LSP}) / (\text{HSP-LSP}))) + \text{Fixed1 Comp} + \text{Fixed2 Comp}$$

[See figure 21, page 70](#)

## [Ext 3 Comp] : (Fixed three Compensation)

Default	0.00
Minimum	0.00
Maximum	327.67
Unit	%, kPa, bar, psi
Modbus Address	%mw520

If **[FixedComp]** is selected as the method of compensation in screen **[<EXPANSION>** ~ **[FLOW COMP]** ~ **[Comp Select]** the system will compensate for flow based firstly on Variable speed pump and then on the number of external pumps that are running. The value entered in this screen is added to the applied setpoint when three external pumps are required to run. The total compensation would be:

$$(\text{Var Comp} * ((\text{Actual Speed-LSP}) / (\text{HSP-LSP}))) + \text{Fixed1 Comp} + \text{Fixed2 Comp} + \text{Fixed3 Comp}$$

[See figure 21, page 70](#)

# Parameter Descriptions

## Flow Compensation

The following diagram describes the Flow Compensation

Figure 20

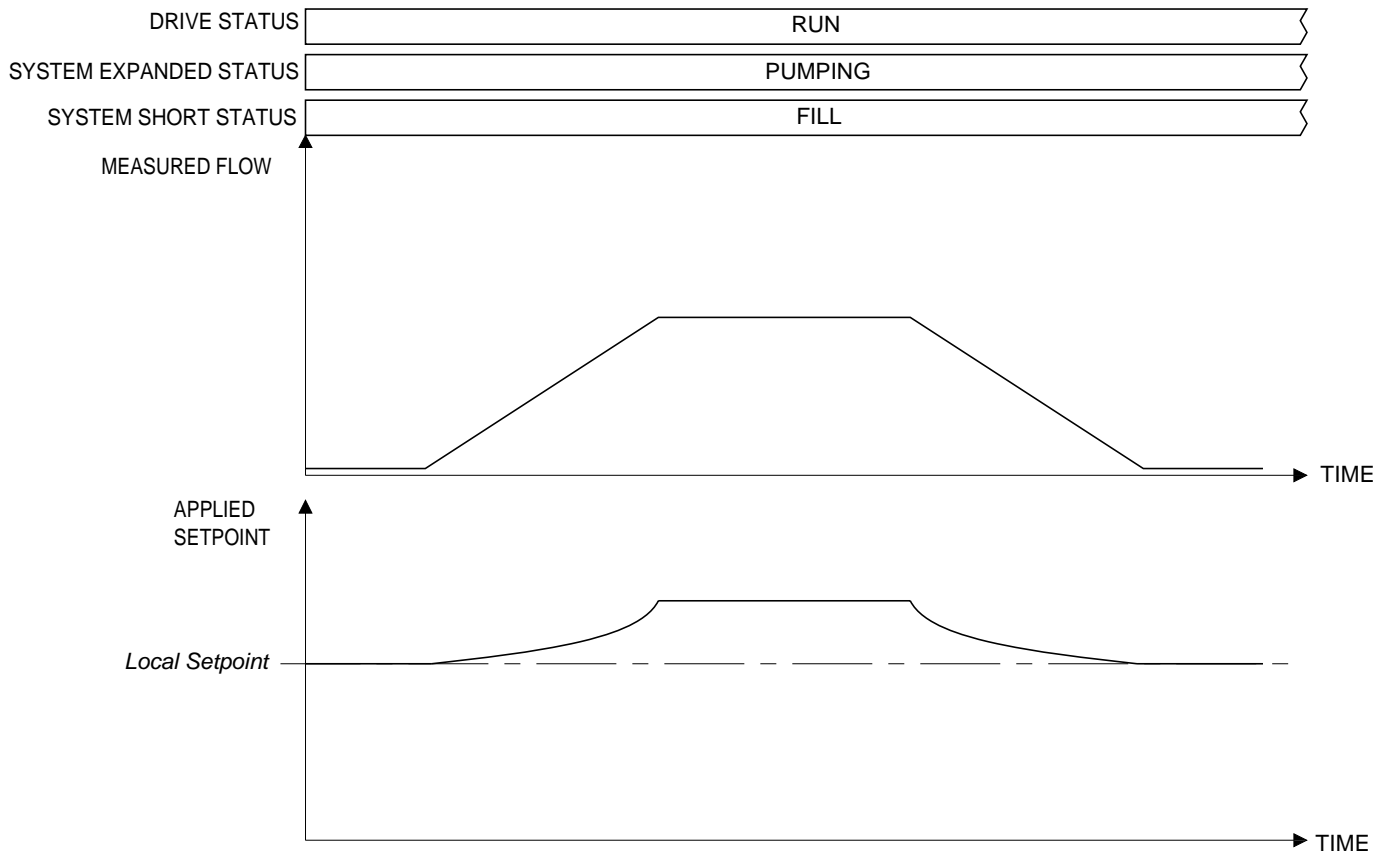

# Parameter Descriptions

The following diagram describes the Fixed Compensation

Figure 21

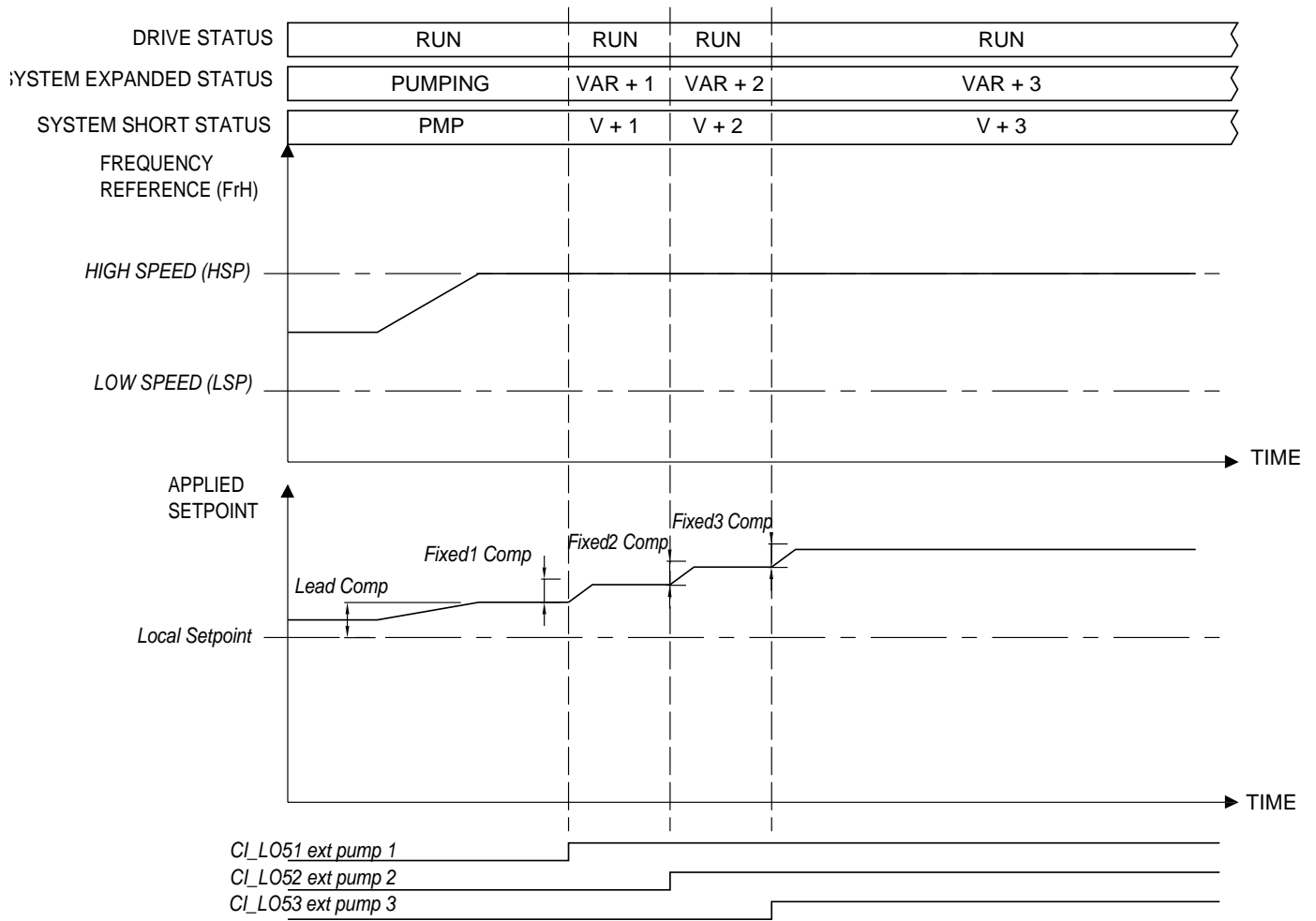

# Parameter Descriptions

## [1.14 - WATER SOLUT.] ~ [<EXPANSION>] ~ [INLET PRO] ~

### [Inlet Protect] : (Inlet Protection)

Default	[Disable]
Range	[Disable] or [Enable]
Modbus Address	%mw522

This parameter enables or disables the Inlet Protection function of the Water Solution card.

The inlet protection algorithm protects the controlled pump from low inlet pressure. The algorithm does this by reducing the applied setpoint which in turn reduces the output speed of the pump. For this function to be enabled, a pressure transducer must be installed on the suction side of the pump and connected to one of the available analogue inputs.

The applied setpoint is reduced by the value entered in screen :

[<EXPANSION>] ~ [INLET PROT] ~ [Max Comp] linearly between the value entered in screen

[<EXPANSION>] ~ [INLET PROT] ~ [Accept Press] and

[<EXPANSION>] ~ [INLET PROT] ~ [Unaccept Pres]

ie, if the following settings are entered

[Max Comp] = 2bar

[Accept Press] = 1bar

[Unaccept Pres] = 0bar

When the inlet feedback pressure is above 1 bar, no compensation is made. However when the inlet feedback pressure is 0.5 bar the applied setpoint is reduced by 1 bar and when the inlet feedback is 0 bar the applied setpoint is reduced by 2 bar. If in these circumstances the applied setpoint was in fact 2 bar the applied setpoint would be reduced to 0 bar and the system will reduce speed and enter the sleep state if configured for this.

[See figure 22, page 73](#)

### [Inlet Source] : (Inlet Source)

Default	DRIVE_AI1
Range	DRIVE_AI1, DRIVE_AI2, DRIVE_AI3, DRIVE_AI4, CI_AI51, or CI_AI52
Modbus Address	%mw524

This parameter is used to select the Feedback for the Suction Pressure.

Please note that if one of the Water Solution analogue inputs is used for Suction Pressure Feedback, it must be correctly configured in screens [<EXPANSION>] ~ [CONFIG] ~ [CI\_AI51 Type] or [<EXPANSION>] ~ [CONFIG] ~ [CI\_AI52 Type] respectively.

[See figure 22, page 73](#)

### [Accept Press] : (Acceptable Pressure)

Default	0.0
Minimum	[Unaccept Pres]
Maximum	3276.7
Unit	%, kPa, bar, psi
Modbus Address	%mw526

If the inlet pressure falls below this value the inlet compensation algorithm becomes active. The applied setpoint is reduced by the value entered in screen [<EXPANSION>] ~ [INLET PROT] ~ [Max Comp] linearly between the value entered in this screen and the screen [<EXPANSION>] ~ [INLET PROT] ~ [Unaccept Pres]

[See figure 22, page 73](#)

# Parameter Descriptions

---

## [Unaccept Pres] : (Unacceptable Pressure)

Default	0.0
Minimum	0.0
Maximum	<a href="#">[Accept Press]</a>
Unit	%, kPa, bar, psi
Modbus Address	%mw528

If the inlet pressure falls below the value entered in screen [\[<EXPANSION>\]](#) ~ [\[INLET PROT\]](#) ~ [\[Accept Press\]](#) the inlet compensation algorithm becomes active. The applied setpoint is reduced by the value entered in screen [\[<EXPANSION>\]](#) ~ [\[INLET PROT\]](#) ~ [\[Max Comp\]](#) linearly between the value entered in screen [\[<EXPANSION>\]](#) ~ [\[INLET PROT\]](#) ~ [\[Accept Press\]](#) and the value entered in this screen.

[See figure 22, page 73](#)

## [Max Comp] : (Maximum Compensation)

Default	0.0
Minimum	0.0
Maximum	3276.7
Unit	%, kPa, bar, psi
Modbus Address	%mw530

If the inlet pressure falls below the value entered in screen [\[<EXPANSION>\]](#) ~ [\[INLET PROT\]](#) ~ [\[Accept Press\]](#) the inlet compensation algorithm becomes active. The applied setpoint is reduced by the value entered in this screen linearly between the value entered in screen [\[<EXPANSION>\]](#) ~ [\[INLET PROT\]](#) ~ [\[Accept Press\]](#) and the value entered in screen [\[<EXPANSION>\]](#) ~ [\[INLET PROT\]](#) ~ [\[Unaccept Pres\]](#).

[See figure 22, page 73](#)

# Parameter Descriptions

## Inlet Protection

The following diagram describes the Inlet Protection

Figure 22

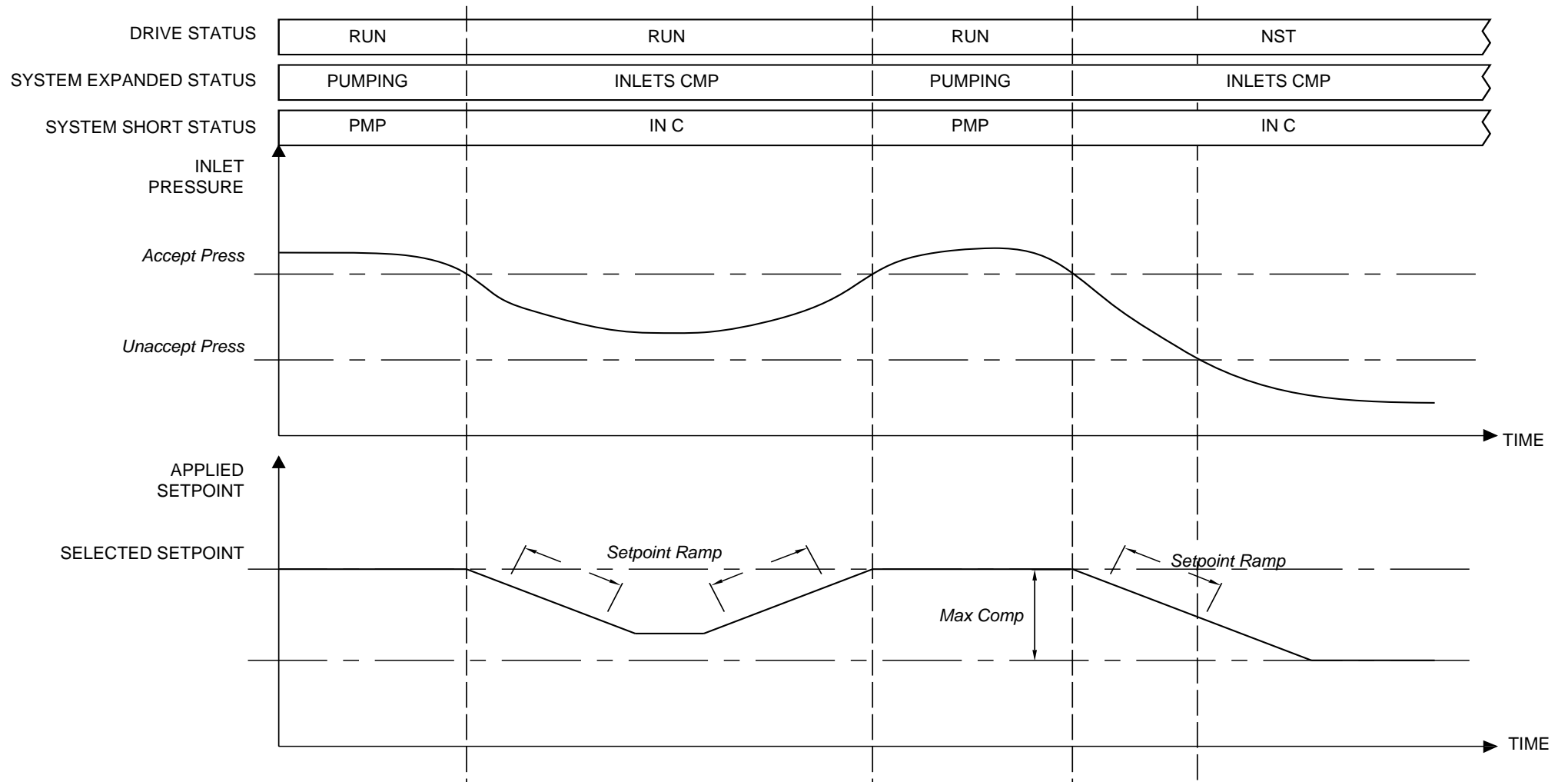

# Parameter Descriptions

---

## [1.14 - WATER SOLUT.] ~ [<EXPANSION>] ~ [ANTI JAM] ~

### [Anti Jam] : (Anti Jam)

Default	[Disable]
Range	[Disable] or [Enable]
Modbus Address	%mw534

This parameter enables or disables the Anti Jam function of the Water Solution card.

The Anti Jam function is used to dislodge any product or detritus that may be attached to the pump impeller. It may also be used to clear a blocked pipe or valve. The Anti Jam function works by rapidly accelerating and decelerating the pump. If triggered the Anti Jam function will accelerate the motor to the speed set in screen [<EXPANSION>] ~ [ANTI JAM] ~ [Fwd Speed] at the rate entered in screen [<EXPANSION>] ~ [ANTI JAM] ~ [AJAM Accel]. It will remain at this speed for the time entered in screen [<EXPANSION>] ~ [ANTI JAM] ~ [Fwd Time]. Once this time expires the motor will be decelerated to the speed entered in screen [<EXPANSION>] ~ [ANTI JAM] ~ [Rev Speed] at the rate entered in screen [<EXPANSION>] ~ [ANTI JAM] ~ [AJAM Decel]. It will remain at this speed for the time entered in screen [<EXPANSION>] ~ [ANTI JAM] ~ [Rev Time]. This complete forward reverse cycle will continue for the amount of times entered in screen [<EXPANSION>] ~ [ANTI JAM] ~ [No Cycles].

The Anti Jam function can be triggered in one of three ways which are selected in screen [<EXPANSION>] ~ [ANTI JAM] ~ [Trigger].

[See figure 23, page 77](#)

### [Trigger] : (Trigger)

Default	[DRIVE_LI1]
Range	[Current], DRIVE_LI1 or [Stopped]
Modbus Address	%mw536

This parameter is used to select the trigger condition to instigate an Anti Jam cycle. If current is selected and the Anti Jam function is enabled, a cycle will commence when the motor current is above the value entered in screen [<EXPANSION>] ~ [ANTI JAM] ~ [Current] for the time entered in screen [<EXPANSION>] ~ [ANTI JAM] ~ [Cur Time].

If DRIVE\_LI1 is selected and the Anti Jam function is enabled a cycle will commence on the rising edge of digital input DRIVE\_LI1. If [Stopped] is selected and the Anti Jam function is enabled a cycle will commence after the system has stopped automatically (CI\_LI57 / auto run command is still true) for the time entered in screen [<EXPANSION>] ~ [ANTI JAM] ~ [Stop Time].

[See figure 23, page 77](#)

### [No Cycles] : (Number of Cycles)

Default	10
Minimum	0
Maximum	999
Modbus Address	%mw538

If the Anti Jam function is enabled and a cycle has been triggered the forward / reverse cycle will be repeated for the amount of times entered in this screen.

[See figure 23, page 77](#)

### [Current] : (Current)

Default	3276.7
Minimum	0
Maximum	2 * Drive rated current
Unit	A
Modbus Address	%mw540

If [Current] is selected and the Anti Jam function is enabled a cycle will commence when the motor current is above the value entered in this screen for the time entered in screen [<EXPANSION>] ~ [ANTI JAM] ~ [Cur Time].

[See figure 23, page 77](#)

# Parameter Descriptions

---

## [Cur Time] : (CurrentTime)

Default	30
Minimum	1
Maximum	32767
Unit	sec
Modbus Address	%mw542

If **[Current]** is selected and the Anti Jam function is enabled a cycle will commence when the motor current is above the value entered in screen [**<EXPANSION>**] ~ **[ANTI JAM]** ~ **[Current]** for the time entered in this screen.

[See figure 23, page 77](#)

## [Stop Time] : (Stop Time)

Default	10
Minimum	1
Maximum	32767
Unit	sec
Modbus Address	%mw544

If **[Stopped]** is selected and the Anti Jam function is enabled a cycle will commence after the system has stopped automatically (CI\_LI57/ auto run command is still true) for the time entered in this screen.

[See figure 23, page 77](#)

## [Fwd Speed] : (Forward Speed)

Default	0
Minimum	LSP
Maximum	HSP
Unit	Hz
Modbus Address	%mw546

If triggered the Anti Jam function will accelerate the motor to the speed set in this screen at the rate entered in screen [**<EXPANSION>**] ~ **[ANTI JAM]** ~ **[AJAM Accel]**. It will remain at this speed for the time entered in screen [**<EXPANSION>**] ~ **[ANTI JAM]** ~ **[Fwd Time]**.

[See figure 23, page 77](#)

## [Fwd Time] : (Forward Time)

Default	1
Minimum	0
Maximum	32767
Unit	sec
Modbus Address	%mw550

If triggered the Anti Jam function will accelerate the motor to the speed set in screen [**<EXPANSION>**] ~ **[ANTI JAM]** ~ **[Fwd Speed]** at the rate entered in screen [**<EXPANSION>**] ~ **[ANTI JAM]** ~ **[AJAM Accel]**. It will remain at this speed for the time entered in this screen.

[See figure 23, page 77](#)

# Parameter Descriptions

---

## [Rev Speed] : (Reverse Speed)

Default	0
Minimum	-HSP
Maximum	-LSP
Unit	Hz
Modbus Address	%mw548

If triggered the Anti Jam function will decelerate the motor to the speed set in this screen at the rate entered in screen [**<EXPANSION>**] ~ [**ANTI JAM**] ~ [**AJAM Decel**]. It will remain at this speed for the time entered in screen [**<EXPANSION>**] ~ [**ANTI JAM**] ~ [**Rev Time**].

[See figure 23, page 77](#)

## [Rev Time] : (Reverse Time)

Default	1
Minimum	0
Maximum	32767
Unit	sec
Modbus Address	%mw552

If triggered the Anti Jam function will decelerate the motor to the speed set in screen [**<EXPANSION>**] ~ [**ANTI JAM**] ~ [**Rev Speed**] at the rate entered in screen [**<EXPANSION>**] ~ [**ANTI JAM**] ~ [**AJAM Decel**]. It will remain at this speed for the time entered in this screen.

[See figure 23, page 77](#)

## [AJAM Accel] : (Anti Jam Acceleration)

Default	3.0
Minimum	0
Maximum	999.9
Unit	sec
Modbus Address	%mw554

If triggered the Anti Jam function will accelerate the motor to the speed set in screen [**<EXPANSION>**] ~ [**ANTI JAM**] ~ [**Fwd Speed**] at the rate entered in this screen. It will remain at this speed for the time entered in screen [**<EXPANSION>**] ~ [**ANTI JAM**] ~ [**Fwd Time**].

[See figure 23, page 77](#)

## [AJAM Decel] : (Anti Jam Deceleration)

Default	3.0
Minimum	0
Maximum	999.9
Unit	sec
Modbus Address	%mw556

If triggered the Anti Jam function will decelerate the motor to the speed set in screen [**<EXPANSION>**] ~ [**ANTI JAM**] ~ [**Rev Speed**] at the rate entered in this screen. It will remain at this speed for the time entered in screen [**<EXPANSION>**] ~ [**ANTI JAM**] ~ [**Rev Time**].

[See figure 23, page 77](#)

# Parameter Descriptions

## Anti Jam

The following diagram describes the Anti Jam

Figure 23

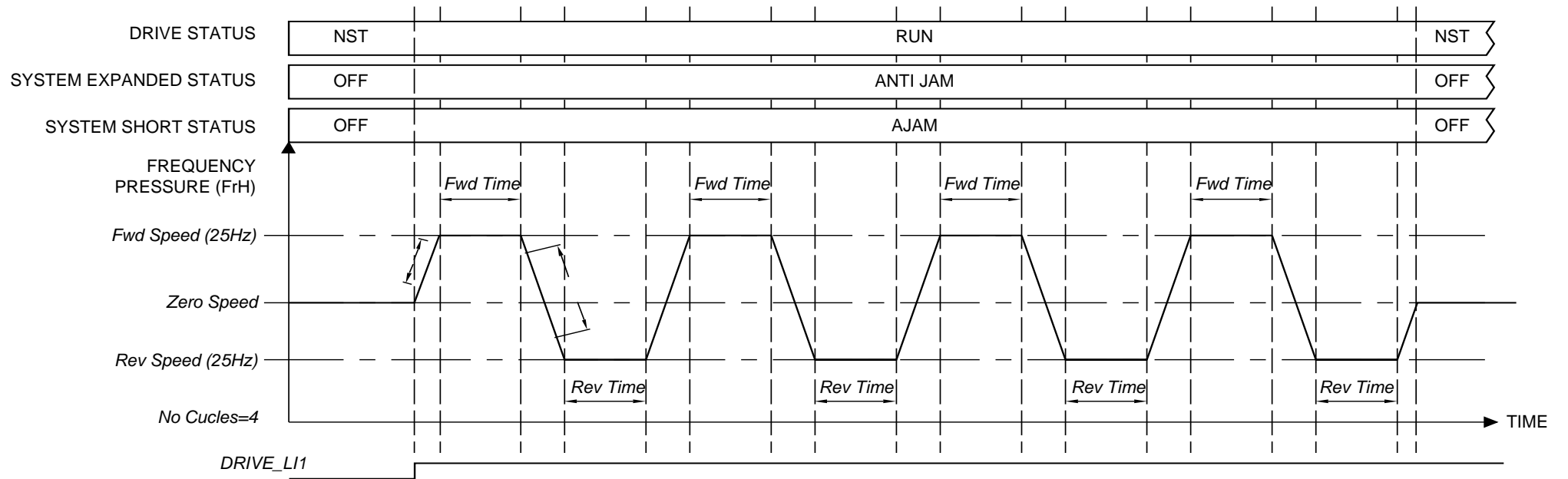

# Parameter Descriptions

---

## [1.14 - WATER SOLUT.] ~ [<EXPANSION>] > ~ [FROST PRO] ~

### [Frost Protect] : (Frost Protect)

Default	[Disable]
Range	[Disable] or [Enable]
Modbus Address	%mw558

This parameter enables or disables the frost protection function of the Water Solution card. For the frost protection algorithm to work a temperature transducer must be installed and connected to one of the available analogue inputs.

If frost protection is enabled and the measured temperature falls below the value set in screen [<EXPANSION>] ~ [FROST PRO] ~ [Alarm Temp] then digital output DRIVE\_RELAY1 will be energised. The relay will only remain energised for as long as the temperature remains below the [Alarm Temp].

If frost protection is enabled and the measured temperature falls below the value set in screen [<EXPANSION>] ~ [FROST PRO] ~ [Protect Temp] Digital output DRIVE\_RELAY2 will be energised and the Variable speed pump will be started. The system will now operate as a normal system using the PID reference selected in screen [<EXPANSION>] ~ [FROST PRO] ~ [Frost PID Ref].

The relay and system will remain on until the measured temp is above [Protect Temp] and either the reset button on the display is pressed or digital input CI\_L158 is energised to reset the system.

[See figure 24, page 80](#)

### [Frost FB] : (Frost Feedback)

Default	DRIVE_AI1
Range	DRIVE_AI1, DRIVE_AI2, DRIVE_AI3, DRIVE_AI4, CI_AI51, or CI_AI52
Modbus Address	%mw560

This parameter is used to select the Feedback for the Water Solution card Frost Protection temperature transducer.

Please note that if one of the Water Solution analogue inputs is used for Temperature Feedback, it must be correctly configured in screens [<EXPANSION>] ~ [CONFIG] ~ [CI\_AI51 Type] or [<EXPANSION>] ~ [CONFIG] ~ [CI\_AI52 Type] respectively.

[See figure 24, page 80](#)

### [Alarm Temp] : (Alarm Temperature)

Default	0.0
Minimum	-3276.7
Maximum	3276.7
Unit	deg
Modbus Address	%mw562

If frost protection is enabled and the measured temperature falls below the value set in this screen, Digital output DRIVE\_RELAY1 will be energised. The relay will only remain energised for as long as the temperature remains below that entered in this screen.

[See figure 24, page 80](#)

# Parameter Descriptions

## [Protect temp] : (Protection Temperature)

Default	0.0
Minimum	-3276.7
Maximum	3276.7
Unit	deg
Modbus Address	%mw564

If frost protection is enabled and the measured temperature falls below the value set in this screen, Digital output DRIVE\_RELAY2 will be energised and the Variable speed pump will be started. The system will now operate as a normal system using the PID reference selected in screen [[<EXPANSION>](#)] ~ [[FROST PRO](#)] ~ [[Frost PID Ref](#)]. The relay and system will remain on until the measured temp is above [[Protect Temp](#)] and either the reset button on the display is pressed or digital input CI\_LI58 is energised to reset the system.

### WARNING

#### INJURY FROM UNEXPECTED MOVEMENTS

Once activated frost protection pumping can only be prematurely stopped by disabling the function in screen [[<EXPANSION>](#)] ~ [[FROST PRO](#)] ~ [[Frost Protect](#)].

**Failure to follow this instruction can result in death, serious injury, or equipment damage.**

Please note that the auto run command (CI\_LI57) is not necessary for the frost protection to operate.

[See figure 24, page 80](#)

## [Actual temp] : (Actual Temperature)

Minimum	-3276.7
Maximum	3276.7
Unit	deg
Modbus Address	%mw566

This screen is used to display the measured temperature.

## [Frost PID Ref] : (Frost Protection PID Reference)

Default	0.0
Minimum	0
Maximum	6553.5
Unit	%, kPa, bar, psi
Modbus Address	%mw568

If frost protection is enabled and the measured temperature falls below the value set in screen [[<EXPANSION>](#)] ~ [[FROST PRO](#)] ~ [[Protect Temp](#)], Digital output DRIVE\_RELAY2 will be energised and the Variable speed pump will be started. The system will now operate as a normal system using the PID reference selected in this screen. The relay and system will remain on until the measured temp is above [[Protect Temp](#)] and either the reset button on the display is pressed or digital input CI\_LI58 is energised to reset the system.

Please note that the auto run command (CI\_LI57) is not necessary for the frost protection to operate.

[See figure 24, page 80](#)

# Parameter Descriptions

## Frost Protection

The following diagram describes the Frost Protection

Figure 24

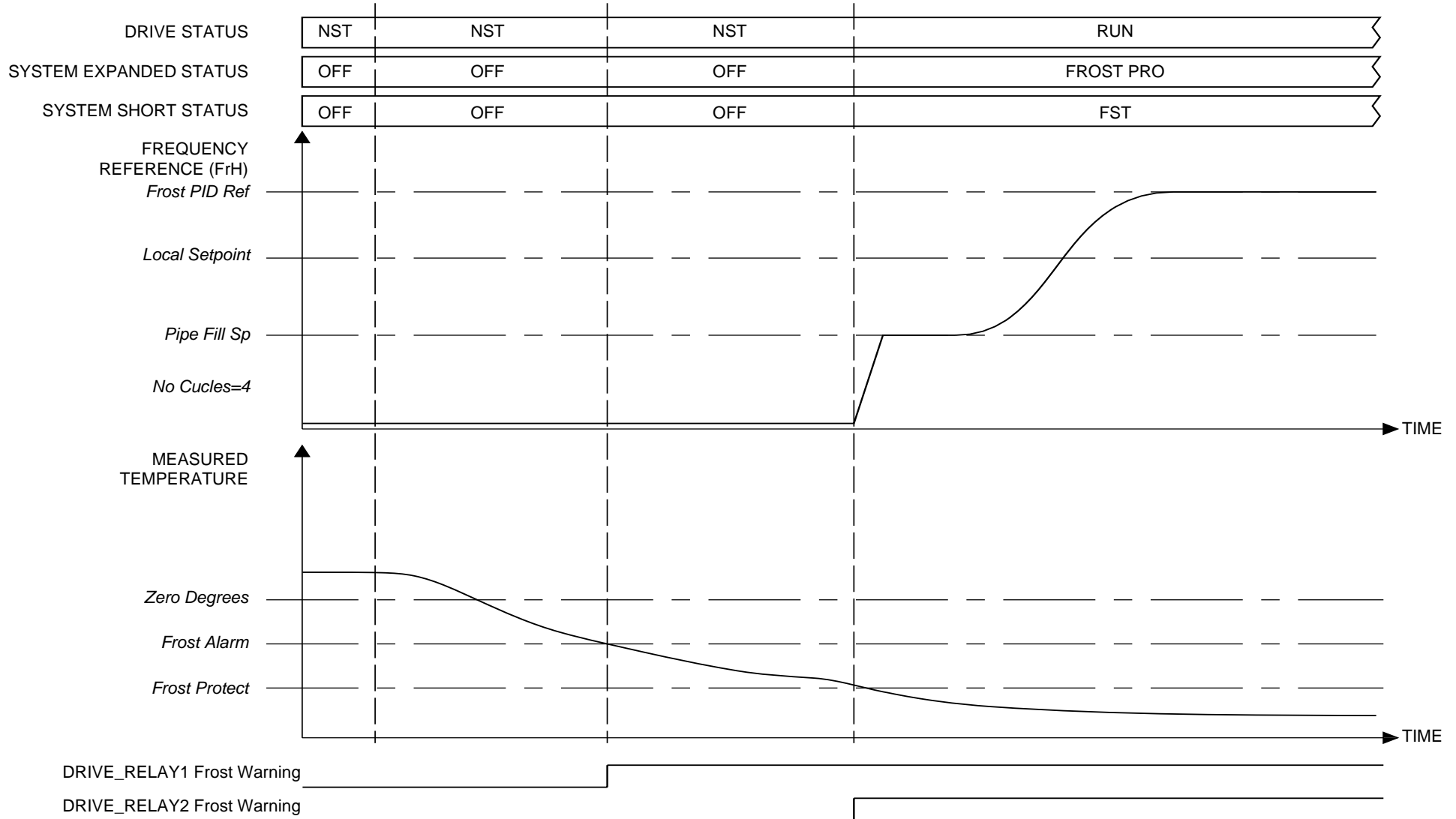

# Parameter Descriptions

---

## [1.14 - WATER SOLUT.] ~ [<EXPANSION>] ~ [SAVED TIME] ~

### [Var Time] : (Var Time)

Default	0
Minimum	0
Maximum	65535
Unit	Hrs or Min
Modbus Address	%mw578

This screen displays the hours the Variable speed pump has been running since it was last reset. When displayed this parameter may be overwritten to reset back to zero or any number desired. If **[Minutes]** is selected in screen **[<EXPANSION>] ~ [SAVED TIME] ~ [Time Base]** the value is incremented every minute that the Variable speed pump is running.

Please note that when displayed this parameter is not updated.

### [Ext1 Time] : (External Pump One Time)

Default	0
Minimum	0
Maximum	65535
Unit	Hrs or Min
Modbus Address	%mw580

This screen displays the hours external pump one has been running since it was last reset. When displayed this parameter may be overwritten to reset back to zero or any number desired. If **[Minutes]** is selected in screen **[<EXPANSION>] ~ [SAVED TIME] ~ [Time Base]** the value is incremented every minute that external pump one is running.

Please note that when displayed this parameter is not updated.

### [Ext2 Time] : (External Pump Two Time)

Default	0
Minimum	0
Maximum	65535
Unit	Hrs or Min
Modbus Address	%mw582

This screen displays the hours external pump two has been running since it was last reset. When displayed this parameter may be overwritten to reset back to zero or any number desired. If **[Minutes]** is selected in screen **[<EXPANSION>] ~ [SAVED TIME] ~ [Time Base]** the value is incremented every minute that external pump two is running.

Please note that when displayed this parameter is not updated.

### [Ext3 Time] : (External Pump Three Time)

Default	0
Minimum	0
Maximum	65535
Unit	Hrs or Min
Modbus Address	%mw584

This screen displays the hours external pump three has been running since it was last reset. When displayed this parameter may be overwritten to reset back to zero or any number desired. If **[Minutes]** is selected in screen **[<EXPANSION>] ~ [SAVED TIME] ~ [Time Base]** the value is incremented every minute that external pump three is running.

Please note that when displayed this parameter is not updated.

# Parameter Descriptions

---

## [Jky Time] : (Jockey Pump Time)

Default	0
Minimum	0
Maximum	65535
Unit	Hrs or Min
Modbus Address	%mw586

This screen displays the hours the jockey pump has been running since it was last reset. When displayed this parameter may be overwritten to reset back to zero or any number desired. If **[Minutes]** is selected in screen **[<EXPANSION> ~ [SAVED TIME] ~ [Time Base]** the value is incremented every minute that the jockey pump has been running.

Please note that when displayed this parameter is not updated.

## [Time Base] : (Time Base)

Default	<b>[Hours]</b>
Range	Hours or Minutes
Modbus Address	%mw588

For commissioning purposes the user can select to have the pump run time hours increment on a per minute basis. This parameter should always be reset to **[Hours]** at the completion of commissioning.

Please note that in case of a switch Hours / Minutes to Minutes / Hours, only the unit changes, actual time value is not modified.

# Parameter Descriptions

---

## [1.14 - WATER SOLUT.] ~ [<EXPANSION>] ~ [CONFIG] ~

### [CI\_AI51 Type] : (Water Solution Analogue Input 51)

Default	4-20 mA
Range	4-20 mA or 0-20 mA
Modbus Address	%mw570

This parameter allows the user to select the type of transducer being installed.

### [CI\_AI52 Type] : (Water Solution Analogue Input 52)

Default	4-20mA
Range	4-20 mA or 0-20 mA
Modbus Address	%mw572

This parameter allows the user to select the type of transducer being installed.

### [Stop Type] : (Stop Type)

Default	Ramp
Range	Ramp or Wheel
Modbus Address	%mw574

This parameter allows the user to select the stop type. At times ramp stop is not suitable for the pump being controlled so the user can select Wheel which causes the motor to stop using the freewheel stop type.

Please note that the setting in this screen has priority over [1.7 APPLICATION FUNCT] [STOP CONFIGURATION] [TYPE OF STOP](Stt)

### [Fault Ramp] : (Fault Ramp)

Default	3.0
Minimum	0.0
Maximum	999.9
Unit	sec
Modbus Address	%mw576

This parameter sets the ramp rate to be used when a fault occurs.

### [Fault Hist] : (Fault History)

Default	0
Minimum	0
Maximum	8888
Modbus Address	%mw592

This parameter shows a history of application faults in a numerical format. A maximum of four digits will be displayed with the left most digit giving the code for the oldest application fault and the right hand digit giving the code for the most recent application fault. The fault codes are as follows:

- 1 Flow switch fault.
- 2 Flow rate fault
- 3 Analogue high pressure fault
- 4 Cavitation fault
- 5 Cycle fault
- 6 Minimum pressure fault
- 7 Low level fault
- 8 Digital high pressure fault

If this screen displays 3622 then the last two faults were flow rate, the fault immediately prior to these was a minimum pressure fault and the oldest recorded fault was an analogue high pressure fault. The value in this screen is not write protected so may be reset to zero.

# Parameter Descriptions

---

## [Version] : (Version)

Minimum	1101
Maximum	9999
Modbus Address	%mw590

This parameter gives the current version of the software application.

Example:

Version : 1101

It means that the software application is v1.1 ie 01

# Configuration Record

The values given in the Example column of this document are for a system comprising of a Variable speed pump and one external direct on line pump. The system pipe work is rated for a maximum of 6 bars and the desired constant pressure is 4 bars. The system IO is as follow

## [START SET]

Parameter	Minimum	Maximum	Modbus	Example		Record 1	Record 2
[Start Press]	[Pipe Fill P]	[PID Max Ref]	%MW300	2.0	bar	bar	bar
[Start Delay]	0	999	%MW302	30	sec	sec	sec
[Pipe Fill P]	0	[Start Press]	%MW304	1.0	bar	bar	bar
[Pipe Fill Spd]	LSP	HSP	%MW306	35	Hz	Hz	Hz
[Pipe Fill Lim]	0	32767	%MW308	300	sec	sec	sec
[Setpoint Ramp]	0.01	327.67	%MW310	0.02	Un/s	Un/s	Un/s
[Man Speed]	LSP	HSP	%MW312	40	Hz	Hz	Hz

NST	APP	0.0Hz	OFF
1,14 WATER SOLUT.			
←EXPANSION→		:	START SET
Start Press	:	0.5	Bar
Start Delay	:	30	sec
Pipe Fill P	:	0.4	Bar
Pipe Fill Spd	:	25	Hz
Code	<<	>>	Quick
Pipe Fill Lim	:	10	sec
SetpointRamp	:	0.05	Un/s
Man Speed	:	35	Hz

# Configuration Record

## [SLEEP SET]

Parameter	Minimum	Maximum	Modbus	Example		Record 1	Record 2
[Sleep Delay]	0	3600	%MW314	60	sec	sec	sec
[Sleep Speed]	LSP	HSP	%MW316	32	Hz	Hz	Hz
[Sleep Flow]	0.00	65535	%MW318	0.00	l/s	l/s	l/s
[Sleep Current]	0.0	3276,7	%MW320	0	A	A	A
[Flow Sw Sleep]	NA	NA	%MW322	[Enable]			
[Adv Sleep]	NA	NA	%MW324	[Enable]			
[Adv Check Sp]	LSP	HSP	%MW326	40	Hz	Hz	Hz
[Adv Test Time]	0	9999	%MW328	300	sec	sec	sec
[Adv Speed]	LSP	HSP	%MW330	30	Hz	Hz	Hz
[Slp Bst Speed]	LSP	HSP	%MW332	0	Hz	Hz	Hz
[Slp Bst Time]	0	250	%MW334	0	sec	sec	sec

NST	APP	0.0 <sub>Hz</sub>	OFF
1,14 WATER SOLUT. <input type="checkbox"/>			
←EXPANSION→		:	SLEEP SET
Sleep Delay	:	20	sec
Sleep Speed	:	30	Hz
Sleep Flow	:	0	l/s
Sleep Current	:	0.0	A
Code	<<	>>	Quick <input type="checkbox"/>
Flow Sw Sleep	:	Disable	
Adv Sleep	:	Disable	
Adv Check Sp	:	0	Hz
Adv Test Time	:	0	sec
Adv Speed	:	0	Hz
Slp Bst Speed	:	0	Hz
Slp Bst Time	:	0	sec

# Configuration Record



[RESET FLT]	Parameter	Minimum	Maximum	Modbus	Example	Record 1	Record 2
	[No Reset Att]	0	10	%MW336	2		
	[Decrement Dly]	0	9999	%MW338	1800	sec	sec
	[Reset Pause]	0	9999	%MW340	120	sec	sec
	[Hi P Fault]	0	2	%MW342	[Aut Reset]		
	[Hi P Level]	0	3276.7	%MW344	5.0	bar	bar
	[Hi P Delay]	0	999	%MW346	30	sec	sec
	[Cavit Fault]	0	2	%MW348	[Disable]		
	[Cavit Current]	0	2*Inv (drive rated current)	%MW350	0.0	A	A
	[Cavit Speed]	LSP	HSP	%MW352	50	Hz	Hz
	[Cavit Time]	0	999	%MW354	30	sec	sec
	[Flow Fault]	0	2	%MW356	[Aut Reset]		
	[Lo Flow Sel]	0	2	%MW358	[Flow sw]		
	[Lo Flow Level]	0	327.67	%MW360	0	l/s	l/s
	[Lo Flow Speed]	0	250	%MW362	37	Hz	Hz
	[Lo Flow Delay]	0	999	%MW364	60	sec	sec
	[Lo Flow Filter]	0	999	%MW366	5	sec	sec
	[Fill Flow Pro]	No	Yes	%MW368	No		

NST		APP		0.0Hz		OFF	
1,14 WATER SOLUT.							
← EXPANSION →				:	RESET FLT		
No Reset Att				:	5		
Decrement Dly				:	3600 sec		
Reset Pause				:	60 sec		
Hi P Fault				:	Disable		
Code	<<	>>	Quick				
High P Level				:	5.0 Bar		
Hi P Delay				:	10 sec		
Cavit Fault				:	Disable		
Cavit Current				:	0.0 A		
Cavit Speed				:	50 Hz		
Cavit Time				:	10 sec		
Flow Fault				:	Disable		
Lo Flow Sel				:	Flow Sw		
Lo Flow Level				:	0 l/s		
Lo Flo Speed				:	25 Hz		
Lo Flo Delay				:	30 sec		
Lo Flo Filter				:	2 sec		
Fill Flow Pro				:	Yes		

# Configuration Record

## [NRESET FL]



Parameter	Minimum	Maximum	Modbus	Example		Record 1	Record 2
[Cycle Time]	0	3600	%MW370	60	sec	sec	sec
[Cycle Count]	0	99	%MW372	3			
[Min Press Flt]	0	1	%MW374	[Disable]			
[Min Press Lev]	0	32767	%MW376	0.0	bar	bar	bar
[Min Press Dly]	0	3600	%MW378	10	sec	sec	sec
[Low Level]	0	1	%MW380	[Enable]			
[Low Level Dly]	0	3600	%MW382	2	sec	sec	sec

NST	APP	0.0Hz	OFF
1,14 WATER SOLUT. 			
← EXPANSION →		:	NRESET FL
Cycle Time	:	60	sec
Cycle Count	:	3	
Min Press Flt	:	Disable	
Min Press Lev	:	0.0	Bar
Code	<<	>>	Quick 
Min Press Dly	:	10	sec
Low Level	:	Disable	
Low Level Dly	:	2	sec

# Configuration Record

## [SENSORS]



Parameter	Minimum	Maximum	Modbus	Example		Record 1	Record 2
[Outlet TX Max]	1	3276.7	%MW384	10.0	bar	bar	bar
[Inlet TX Max]	1	3276.7	%MW386	10.0	bar	bar	bar
[Press Units]	0	6	%MW388	bar			
[Flow Source]	-	-	%MW390	None			
[Flow AIN TX]	0.00	65535	%MW392	0	l/s	l/s	l/s
[Pulses/ Volume]	1	655.35	%MW394	1.00	pu/V	pu/V	pu/V
[Volume]	1	65535	%MW396	1	l	l	l
[Flow Units]	0	6	%MW398	litres/s			
[Flow Filter]	0	65535	%MW400	0	sec	sec	sec
[Temp Tx Min]	-32767	0	%MW402	0	deg	deg	deg
[Temp Tx Max]	0	32767	%MW404	100	deg	deg	deg

NST	APP	0.0Hz	OFF
1,14 WATER SOLUT. 			
← EXPANSION →		:	SENSORS
Outlet Tx Max	:	10.0	Bar
Inlet Tx Max	:	10.0	Bar
Press Units	:	bar	
Flow Source	:	NONE	
Code	←	→	Quick 
Flow AIN Tx	:	0	l/s
Pulses/volume	:	1.00	pu/V
Volume	:	1	l
Flow Units	:	litres/s	
Flow Filter	:	0	sec
Temp Tx Min	:	0	deg
Temp Tx Max	:	100	deg

# Configuration Record

## [FLOW LMT]

Parameter	Minimum	Maximum	Modbus	Example		Record 1	Record 2
[Activate Lim]	0	1	%MW406	[Disable]			
[Flow Limit]	[Flo Lmt Resest]	32767	%MW408	0.00	l/s	l/s	l/s
[Flo Lmt Resest]	0.00	[Flow Limit]	%MW410	0.00	l/s	l/s	l/s
[Flow Lmt Ramp]	0.0	999.9	%MW412	10.0	sec	sec	sec

NST	APP	0.0 <sub>Hz</sub>	OFF
1,14 WATER SOLUT. 			
←EXPANSION→		:	FLOW LMT
Activate Lim	:		Disable
Flow Limit	:		0 l/s
Flo Lmt Reset	:		0 l/s
Flow Lmt Ramp	:		10.0 sec
Code	←	→	Quick 

# Configuration Record

[PID]	Parameter	Minimum	Maximum	Modbus	Example	Record 1	Record 2
[PID Reference]		0	6	%MW414	Local		
[PID Max Ref]		0.0	3276.7	%MW416	3200 bar	bar	bar
[PID Feedback]		0	5	%MW418	DRIVE_AI2		
[PID Gain]		-100.00	+100.00	%MW420	1,4 X	X	X
[PID Integral]		0.00	100.00	%MW422	10.00 sec	sec	sec
[PID Deriv]		0.00	100.00	%MW424	0.00 sec	sec	sec
[PID Accel]		0.0	999.9	%MW426	5.0 sec	sec	sec
[PID Decel]		0.0	999.9	%MW428	5.0 sec	sec	sec
[Strt Accel Rate]		0.0	999.9	%MW430	3.0 sec	sec	sec
[Stp Dec Rate]		0.0	999.9	%MW432	3.0 sec	sec	sec
[Alt Reference]		0	6	%MW434	Local		

NST	APP	0.0Hz	OFF
1,14 WATER SOLUT.			
← EXPANSION →		:	PID
PID Reference		:	LOCAL
PID Max Ref		:	3200.0 Bar
PID Feedback		:	DRIVE_AI2
PID Gain		:	+1.40 x
Code	<<	>>	Quick
PID Integral		:	10.00 sec
PID Deriv		:	0.00 sec
PID Accel		:	5.0 sec
PID Decel		:	5.0 sec
Strt Acc Rate		:	3.0 sec
Stp Dec Rate		:	3.0 sec
Alt Reference		:	LOCAL

# Configuration Record



[STAGE]	Parameter	Minimum	Maximum	Modbus	Example	Record 1	Record 2
	[Number of EXT]	0	3	%MW436	1 pmp		
	[Duty Sharing]	0	1	%MW438	Off		
	[Stage Mode]	0	5	%MW440	Sp+Pr+Dly		
	[Stage Speed] [Stage Byp Spd]		HSP	%MW442	48 Hz	Hz	Hz
	[Stage error]	0	3276.7	%MW444	0.2 bar	bar	bar
	[Stage Delay]	0	3600	%MW446	5 sec	sec	sec
	[Stage Byp Spd]	LSP	[Stage Speed]	%MW448	44 Hz	Hz	Hz
	[Stg Byp Time]	0	3600	%MW450	5 sec	sec	sec
	[Stage Offset]	0	[Stage Speed] - [Stage Byp Spd]	%MW452	0 Hz	Hz	Hz

NST	APP	0.0Hz	OFF
1,14 WATER SOLUT.			
◀ EXPANSION ▶		:	STAGE
Number of EXT	:	0	pmp
Duty Sharing	:	Enable	
Stage Mode	:	Sp+Pr+Dly	
Stage Speed	:	50	Hz
Code	<<	>>	Quick
Stage Error	:	0.0	Bar
Stage Delay	:	5	sec
Stage Byp Spd	:	50	Hz
Stg Byp Time	:	5	sec
Stage Offset	:	0	Hz

# Configuration Record

## [DESTAGE]

Parameter	Minimum	Maximum	Modbus	Example		Record 1	Record 2
[Destage Mode]	0	5	%MW454	Pr Only			
[Destage Speed]	[Dstge Byp Sp]	HSP	%MW456	43	Hz	Hz	Hz
[Destage Error]	-3276.7	0	%MW458	0	bar	bar	bar
[Destage Delay]	1	3600	%MW460	2	sec	sec	sec
[Dstge Byp Sp]	LSP	[Destage Speed]	%MW462	43	Hz	Hz	Hz
[Dstg Byp Time]	0	3600	%MW464	5	sec	sec	sec
[Dstg Offset]	0	[Dstge Byp Sp] - [Destage Speed]	%MW466	0	Hz	Hz	Hz

NST	APP	0.0Hz	OFF
1,14 WATER SOLUT. 			
← EXPANSION →		:	DESTAGE
Destage Mode		:	Sp+Pr+Dly
Destage Speed		:	40 Hz
Destage Error		:	0.0 Bar
Destage Delay		:	1 sec
Code	←	→	Quick 
Dstge Byp Sp		:	40 Hz
Dstg Byp Time		:	5 sec
Dstg Offset		:	0 Hz

# Configuration Record

## [JOCKEY]

Parameter	Minimum	Maximum	Modbus	Example		Record 1	Record 2
[Jockey]	NA	NA	%MW468	[Disable]			
[Jky Stop P]	[Jky Start P]	3276,7	%MW470	0	bar	bar	bar
[Jky Start P]	0	[Jky Stop P]	%MW472	0	bar	bar	bar
[Jky On Delay]	0	3600	%MW474	1	sec	sec	sec

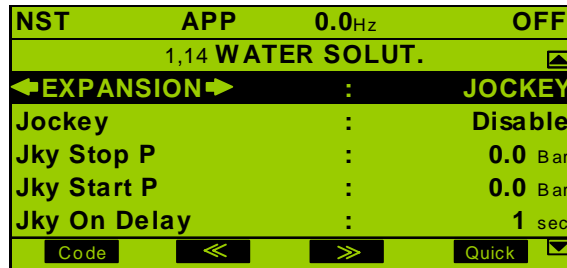



# Configuration Record

---

## [RUN TIMES]



Parameter	Minimum	Maximum	Modbus	Example		Record 1	Record 2
[Timed Pumping]	0	1	%MW476	[Disable]			
[Start Hours]	0	23	%MW478	0	Hrs	Hrs	Hrs
[Start Mins]	0	59	%MW480	0	Min	Min	Min
[Stop Hours]	0	23	%MW482	0	Hrs	Hrs	Hrs
[Stop Mins]	0	59	%MW484	0	Min	Min	Min

NST	APP	0.0Hz	OFF
1,14 WATER SOLUT. 			
←EXPANSION→		:	RUN TIMES
Timed Pumping	:		Disable
Start Hours	:		0 Hrs
Start Mins	:		0 min
Stop Hours	:		0 Hrs
Code		<<	>> Quick 
Stop Mins	:		0 min

# Configuration Record

## [NIGHT&DAY]



Parameter	Minimum	Maximum	Modbus	Example		Record 1	Record 2
[Night & Day]	0	1	%MW486	[Disable]			
[Start Hours]	0	23	%MW488	0	Hrs	Hrs	Hrs
[Start Mins]	0	59	%MW490	0	Min	Min	Min
[Stop Hours]	0	23	%MW492	0	Hrs	Hrs	Hrs
[Stop Mins]	0	59	%MW494	0	Min	Min	Min
[N&D Start P]	0	[N&D Stop P]	%MW496	0	bar	bar	bar
[N&D Stop P]	[N&D Start P]	3276,7	%MW498	0	bar	bar	bar
[Measure Time]	0	32767	%MW500	10	sec	sec	sec
[N&D Speed]	LSP	HSP	%MW502	30	Hz	Hz	Hz
[Cyclic Ratio]	0	32767	%MW504	50	%	%	%
[Restart Time]	0	32767	%MW506	90	sec	sec	sec

NST	APP	0.0Hz	OFF
1,14 WATER SOLUT. 			
◀EXPANSION▶		:	NIGHT&DAY
Night & Day	:	Disable	
Start Hours	:	0 Hrs	
Start Mins	:	0 min	
Stop Hours	:	0 Hrs	
Code	<<	>>	Quick 
Stop Mins	:	0 min	
N&D Start P	:	0.0 Bar	
N&D Stop P	:	0.0 Bar	
Measure Time	:	10 sec	
N&D Speed	:	30 Hz	
Cyclic Ratio	:	50 %	
Restart Time	:	90 sec	

# Configuration Record

## [FLOW COMP]

Parameter	Minimum	Maximum	Modbus	Example	Record 1	Record 2
[Comp Select]	0	2	%MW508	[None]		
[Known Flow]	0.00	32767	%MW510	0.00	l/s	l/s
[Press Drop]	0.0	3276,7	%MW512	0.0	bar	bar
[Var Comp]	0.00	327,67	%MW514	0.00	bar	bar
[Ext 1 Comp]	0.00	327,67	%MW516	0.00	bar	bar
[Ext 2 Comp]	0.00	327,67	%MW518	0.00	bar	bar
[Ext 3 Comp]	0.00	327,67	%MW520	0.00	bar	bar

NST	APP	0.0Hz	OFF
1,14 WATER SOLUT. 			
←EXPANSION→		:	FLOW COMP
Comp Select	:		None
Known Flow	:		0 l/s
Press Drop	:		0.0 Bar
Var Comp	:		0.00 Bar
Code	<<	>>	Quick 
Ext 1 Comp	:		0.00 Bar
Ext 2 Comp	:		0.00 Bar
Ext 3 Comp	:		0.00 Bar

# Configuration Record

## [INLET PRO]



Parameter	Minimum	Maximum	Modbus	Example	Record 1	Record 2
[Inlet Protect]	0	1	%MW522	[Disable]		
[Inlet Source]	0	5	%MW524	DRIVE_AI1		
[Accept Press]	[Unaccept Pres]	3276.7	%MW526	0.0	bar	bar
[Unaccept Pres]	0.0	[Accept Press]	%MW528	0.0	bar	bar
[Max Comp]	0.0	3276.7	%MW530	0.0	bar	bar

NST	APP	0.0 <sub>Hz</sub>	OFF
1,14 WATER SOLUT.			
←EXPANSION→		:	INLET PRO
Inlet Protect	:	Disable	
Inlet Source	:	DRIVE_AI1	
Accept Press	:	0.0 Bar	
Unaccept Pres	:	0.0 Bar	
Code	<<	>>	Quick
Max Comp	:	0.0 Bar	

# Configuration Record

## [ANTI JAM]

Parameter	Minimum	Maximum	Modbus	Example		Record 1	Record 2
[Anti Jam]	0	1	%MW534	[Disable]			
[Trigger]	0	2	%MW536	DRIVE_LI1			
[No Cycles]	1	999	%MW538	10	-	-	-
[Current]	0.0	3276.7	%MW540	60	A	A	A
[Cur Time]	1	32767	%MW542	30	sec	sec	sec
[Stop Time]	1	32767	%MW544	10	sec	sec	sec
[Fwd Speed]	LSP	HSP	%MW546	0	Hz	Hz	Hz
[Fwd Time]	0	32767	%MW550	1	sec	sec	sec
[Rev Speed]	-HSP	-LSP	%MW548	0	Hz	Hz	Hz
[Rev Time]	0	32767	%MW552	1	sec	sec	sec
[AJAM Accel]	0.0	999.9	%MW554	3.0	sec	sec	sec
[AJAM Decel]	0.0	999.9	%MW556	3.0	sec	sec	sec

NST	APP	0.0Hz	OFF
1,14 WATER SOLUT. 			
←EXPANSION→		:	ANTI JAM
Anti Jam	:	:	Disable
Trigger	:	:	DRIVE_LI1
No Cycles	:	:	10
Current	:	:	60 A
Code	<<	>>	Quick 
Cur Time	:	:	30 sec
Stop Time	:	:	10 sec
Fwd Speed	:	:	0 Hz
Fwd Time	:	:	0 sec
Rev Speed	:	:	0 Hz
Rev Time	:	:	1 sec
AJAM Accel	:	:	3.0 sec
AJAM Decel	:	:	3.0 sec

# Configuration Record

## [FROST PRO]

Parameter	Minimum	Maximum	Modbus	Example	Record 1	Record 2
[Frost Protect]	0	1	%MW558	[Disable]		
[Frost FB]	0	5	%MW560	DRIVE_AI4		
[Alarm Temp]	-3276.7	3276.7	%MW562	0.0	deg	deg
[Protect Temp]	-3276.7	3276.7	%MW564	0.0	deg	deg
[Actual Temp]	-3276.7	3276.7	%MW566	0.0	deg	deg
[Frost PID Ref]	0.0	6553.5	%MW568	0.0	bar	bar

NST	APP	0.0Hz	OFF
1,14 WATER SOLUT.			
◀EXPANSION▶		:	FROST PRO
Frost Protect	:	:	Disable
Frost FB	:	:	DRIVE_AI4
Alarm Temp	:	:	0.0 deg
Protect Temp	:	:	0.0 deg
Code	<<	>>	Quick
Actual Temp	:	:	0.0 deg
Frost PID Ref	:	:	0.0 Bar

## [SAVED TIM]

Parameter	Minimum	Maximum	Modbus	Example	Record 1	Record 2
[Var Time]	0	65535	%MW578	0	Hrs	Hrs
[Ext 1 Time]	0	65535	%MW580	0	Hrs	Hrs
[Ext 2 Time]	0	65535	%MW582	0	Hrs	Hrs
[Ext 3 Time]	0	65535	%MW584	0	Hrs	Hrs
[Jockey]	0	65535	%MW586	0	Hrs	Hrs
[Time Base]	NA	NA	%MW588	[Hours]		

2

NST	APP	0.0Hz	OFF
1,14 WATER SOLUT.			
◀EXPANSION▶		:	SAVED TIM
Var Time	:	:	0 Hrs
Ext 1 Time	:	:	0 Hrs
Ext 2 Time	:	:	0 Hrs
Ext 3 Time	:	:	0 Hrs
Code	<<	>>	Quick
Jockey	:	:	0 Hrs
Time Base	:	:	Hours

# Configuration Record

[CONFIG]

Parameter	Minimum	Maximum	Modbus	Example		Record 1	Record 2
[CI_AI51 Type]	NA	NA	%MW570	4-20 mA			
[CI_AI52 Type]	NA	NA	%MW572	4-20 mA			
[Stop Type]	NA	NA	%MW574	[Ramp]			
[Fault Ramp]	0.0	999,9	%MW576	3.0	sec	sec	sec
[Fault Hist]	0	8888	%MW592	2873			
[Version]	1101	9999	%MW590	1101			

NST	APP	0.0Hz	OFF
1,14 WATER SOLUT.			
←EXPANSION→		:	CONFIG
CI_AI51 Type	:	4-20mA	
CI_AI52 Type	:	4-20mA	
Stop Type	:	Ramp	
Fault Ramp	:	3.0 sec	
Code	<<	>>	Quick
Fault Hist	:	0	
Version	:	1101	

