



**INDUSTRIAL/COMMERCIAL**

## Understanding Busway Grounding

Standard integral ground bus on all I-LINE® busway rated 800A-5000A. Optional for 225-600A

Minimum 50% cross sectional area on integral ground path

Ground system designed into housing

Meets all UL857 safety standards

Provides an effective ground path for high level ground faults

### The Difference:

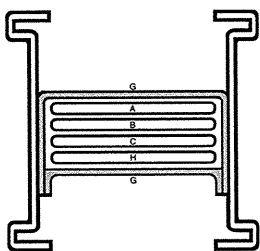

**Integral Ground**

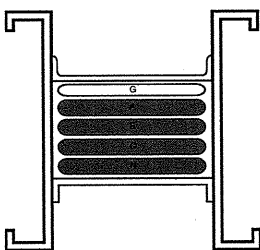

**Internal Ground**

“Integral” ground busway systems use all or part of their housing and are designed-in/built-in, not merely added-on.

An “Internal” ground busway system is constructed with separate ground bars inside the busway, sandwiched with the phase and neutral bus bars. These ground bars are generally smaller than the phase and neutral bus bars.

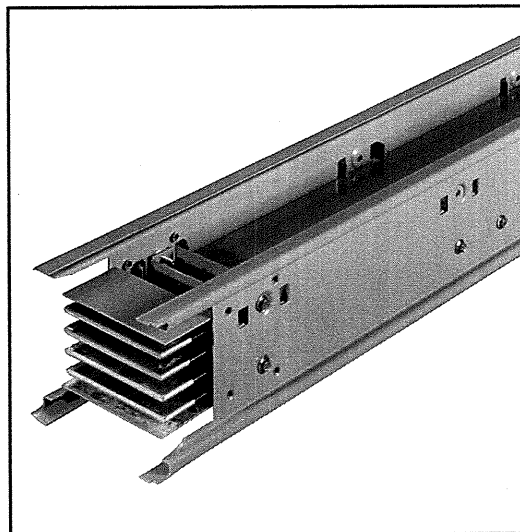

would occur even in electrical systems with a full-rated ground (such as a separate ground wire in a metallic conduit system).

Square D always strives to meet and exceed industry standards, including Underwriters Laboratories’ listing on all our busway products. We put our I-LINE® II Busway, featuring an integral ground system, through a series of rigorous short circuit withstand and phase-to-ground tests. Our products meet all specifications in the UL standard UL857.

Square D’s intergral grounding system goes beyond conventional tests and investigates the behavior of fault currents in busway as they make their way to ground. Normally, under fault conditions, the fault current splits from the ground wire and “leaks” onto the metal exterior housing. Such leakage

### Putting It To The Test

In one Square D evaluation, we connected five 10-foot lengths of internal busway (1200 amperes, copper, “feeder”-type construction). Five tests were conducted and each test lasted three electrical cycles at various voltages and current levels.

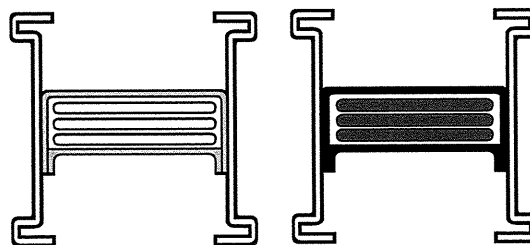

**Normal Construction**

**Steel Top & Bottom**



**SQUARE D**  
GROUPE SCHNEIDER

Tests showed (see table 1) as the fault current level increases, the amount of ground current conducted by the all-steel housing also increases. The graph below illustrates the housing carries more than 20% of the fault current, with the ground current at the 70,000A range. This test was done with an internal 100% capacity ground bar. Had it been a 50% capacity bar, the leakage to the outer housing may have been even greater.

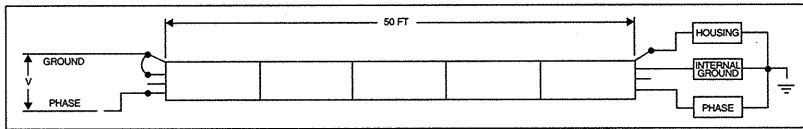

**Table 1**

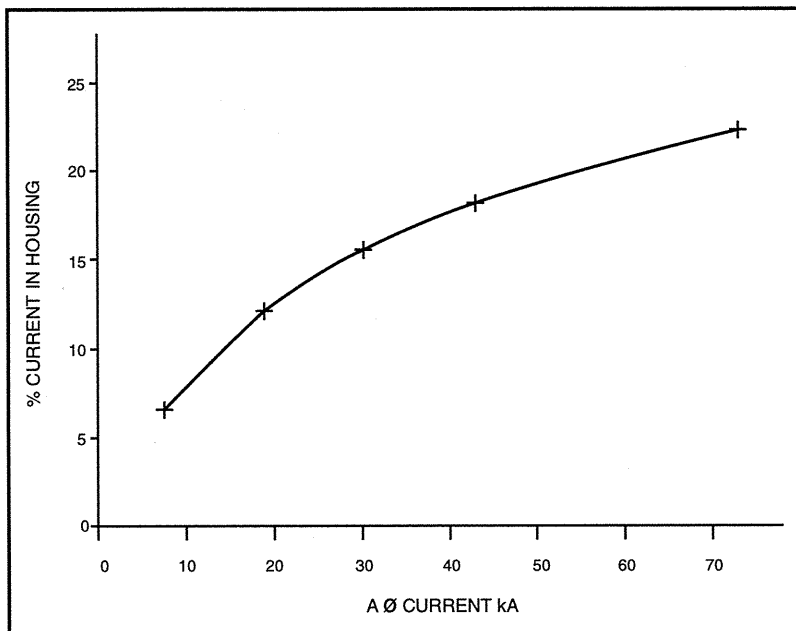

## Carrying Current Efficiently

Grounding systems are required in busway systems to provide a return path to earth for fault currents, which in turn trip the overcurrent protective device. Because the steel housing conducts ground current, it is important that the housing carries this current as efficiently as possible. Since the housing carries current anyway, Square D designed the housing as the ground path.

Table 2 below compares the cross-sectional area of Square D's integral ground bus with that of a conventional 50% ground capacity, 1/8" thick internal ground bar. UL requirements also are listed.

This table also shows that our aluminum 50% capacity integral ground bus has two to three times more cross-sectional area than required by UL, and from 7% to 42% more cross-sectional area than a conventional 1/8" thick "internal" ground bar.

Square D I-LINE Busway Systems meet the demands of a wide range of commercial and industrial power distribution applications. Plug-in style is available (with copper or aluminum conductors) in the 225A to 600A range of I-LINE Busway. For higher amperage ratings, Square D offers I-LINE II Busway in both plug-in and feeder styles. Aluminum busway is available in ratings from 800A to 4000A; copper busway in ratings from 800A to 5000A.

All Square D I-LINE Busway Systems offer many features that improve electrical efficiency and make installation easier.

**Table 2**

AMPS	ALUMINUM BUSBARS					COPPER BUSBARS				
	SQUARE D BAR WIDTH (Inches)	NO. OF BARS PER PHASE	CROSS-SECTIONAL AREA (Sq. In.)			SQUARE D BAR WIDTH (Inches)	NO. OF BARS PER PHASE	CROSS-SECTIONAL AREA (Sq. In.)		
			UL GROUND REQUIREMENT	CONVENTIONAL 1/8" INTERNAL GROUND BUS	SQUARE D INTEGRAL GROUND BUS			UL GROUND REQUIREMENT	CONVENTIONAL 1/8" INTERNAL GROUND BUS	SQUARE D INTEGRAL GROUND BUS
800	3.00	1	0.166	0.372	0.433	2.50	1	0.166	0.309	0.380
1000	4.00	1	0.196	0.497	0.568	3.00	1	0.196	0.372	0.443
1200	5.00	1	0.227	0.622	0.693	4.00	1	0.227	0.497	0.568
1600	7.50	1	0.294	0.934	1.005	5.40	1	0.294	0.672	0.743
2000	4.50	2	0.353	1.118	1.521	6.50	1	0.353	0.809	0.880
2500	6.00	2	0.515	1.498	1.959	4.50	2	0.515	1.118	1.521
3000	7.50	2	0.589	1.868	2.271	5.00	2	0.589	1.243	1.834
4000	6.50	3	0.810	2.427	3.131	4.50	3	0.810	1.677	2.881
5000	—	—	—	—	⊕	6.00	3	1.276	2.240	3.069

SQUARE D I-LINE, and I-Line II are registered trademarks of Square D Company.

Order Number 2700HO9602R6/97 (Replaces 5600PN9101)  
Printed in U.S.A.



**SQUARE D**  
GROUPE SCHNEIDER

© 1997 Square D Company All rights reserved