

Energy Efficient Transformers

Low Voltage General Purpose

Dry Type

Class 7400

Catalog
7400CT0601R3/07

07



CONTENTS

Description	Page
Product Description	2
General Information	3
Three-Phase Transformers	4
240/120 Four-Wire Delta Connection Transformers	8
Single-Phase Transformers	10
Non-Linear Energy Efficient Transformers	11
Watchdog® Low Temperature Rise Transformers	12
Made-To-Order Transformers	14
Enclosure Diagrams and Accessories	16
Wiring Diagrams	28
NEC Reference: Installing and Connecting Transformers	33
Wire Range Part Numbers and Lug Kits	34
Specifications	36
Frequently Asked Questions and Answers	38



Energy Efficient Transformers

Product Description

Product Description

Key Features of the Square D® Energy Efficient Dry-Type Transformers

- Smaller total area used, with 3 in. (76 mm) clearance from ventilated openings instead of 6 in. (152 mm), reducing the distance from the wall to the front of the device by 3 in. (76 mm)
- Terminals are sized to handle lug kits that are coordinated with other Square D® products, increasing the ease of installation when used with other Square D equipment
- Increased wiring compartments provide a bending radius for 250% primary cables and multiple feeds on the secondary
- All units have 200% neutral to allow customers to feed standard and non-linear panels
- 220 °C UL Listed insulation system
- Decreased weight for easier handling of units

Energy Policy Act

The Energy Policy Act of 2005 declared the following information regarding low voltage dry-type distribution transformers:

The efficiency of a low voltage dry-type distribution transformer manufactured on or after January 1, 2007 shall be the Class I Efficiency Levels for distribution transformers specified in Table 4-2 of the *Guide for Determining Energy Efficiency for Distribution Transformers*, published by the National Electrical Manufacturers Association® (NEMA® TP-1—2002).

Schneider Electric introduced the first TP1-compliant low voltage dry-type distribution transformers in December 1998. With the 2005 Energy Act, Schneider Electric is expanding its offering of TP-1-compliant products by launching a new line of TP-1 qualified transformers.

NATURAL RESOURCES CANADA

Natural Resources Canada declared the following information regarding dry-type transformers and the energy performance test procedure:

Dry-Type Transformers

The Office of Energy Efficiency (OEE) of Natural Resources Canada (NRCan) has amended Canada's Energy Efficiency Regulations to require Canadian dealers to comply with minimum energy performance standards for dry-type transformers imported or shipped inter-provincially for sale or lease in Canada.

These regulations and subsequent amendments were published in the *Canadian Gazette Part 1* in May 2006.

Energy Performance Test Procedure

The Canadian Standards Association standard CAN/CSA-C802.2-00, *Minimum Efficiency Values for Dry-Type Transformers*, is the test procedure for transformers under regulation.

The test procedure is the same as that in the National Electrical Manufacturers Association (NEMA TP-1—1996), *Guide for Determining Energy Efficiency for Distribution Transformers* and associated document TP-2—1998, *Standard Test Method for Measuring the Energy Consumption of Distribution Transformers*, in the United States.

General Information

Saving Money by Saving Energy

Minimum efficiencies have been established for each size of transformer, and extensive design, testing, and manufacturing time has been spent to ensure each transformer meets or exceeds these efficiencies.

Surveys show that typical loading of low voltage dry-type transformers on a 24-hour average basis is only 35% of full-load rating. At such loading levels, Square D® Lean Power™ Energy Efficient Transformers manufactured by Schneider Electric provide the best combination of optimal performance and superior quality.

The Square D Energy Efficient transformer offering includes all of the popular options including low temperature rise, 115 °C and 80 °C, and aluminum or copper windings. These transformers are part of a complete line of Lean Power products from Schneider Electric. Our power conservation, management and monitoring products, systems, and services help to reduce energy consumption in business and industry environments.

Table 1: Transformer Efficiency Levels

Single-Phase		Three-Phase	
kVA	% Efficiency	kVA	% Efficiency
15.0	97.7	15.0	97.0
25.0	98.0	30.0	97.5
37.5	98.2	45.0	97.7
50.0	98.3	75.0	98.0
75.0	98.5	112.5	98.2
100.0	98.6	150.0	98.3
167.0	98.7	225.0	98.5
250.0	98.8	300.0	98.6
333.0	98.9	500.0	98.7
—	—	750.0	98.8
—	—	1000.0	98.9

Temperature: 75 °C, 35% of full-load capacity

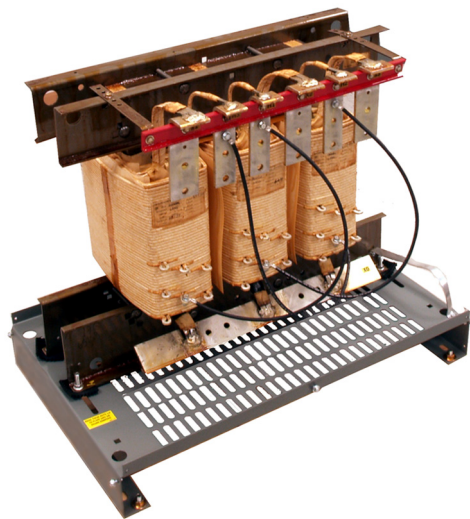

**Three-phase energy efficient transformer
(top cover, and all panels removed)**



Energy Efficient Transformers
Three-Phase Transformers

Three-Phase Transformers

Refer to Tables 2–9 for three-phase transformer information.

Table 2: 480 V Delta Primary to 208Y/120 V Secondary

kVA	Part Number	Enclosure ¹ (Refer to pages 16–27)	Wiring Diagram	Weight (lbs)		°C Rise	Primary Current			Secondary Current	
				Al	Cu (Add CU suffix) ²		Nameplate	NEC Max Rating 125%	NEC Max Rating 250%	Nameplate	NEC Max Rating 125%
15	EE15T3H	17D	Figure 1 on page 28	220	310	150	18.0	25	45	41.7	60
30	EE30T3H	17D		260	340	150	36.1	45	90	83.4	110
45	EE45T3H	18D		320	372	150	54.2	70	125	125.1	175
75	EE75T3H	20D		410	527	150	90.3	125	225	208.4	275
112.5	EE112T3H	21D		620	725	150	135.5	175	300	312.6	400
150	EE150T3H	22D		800	920	150	180.6	225	450	416.9	500
225	EE225T3H	24D		1110	1090	150	271.0	300	600	625.3	800
300	EE300T3H	25D	1359	1535	150	361.3	450	900	833.7	1000	
500	EE500T68H	30D	Figure 2 on page 29	1870	2300	150	602.1	800	1500	1389.5	1600
750	EE750T68H	31D		3060	3710	150	903.2	1000	2000	2084.3	2500
1000 ³	—	—	—	—	—	150	1202.8	1500	3000	2775.7	3000

¹ NEMA Type 2 drip-proof enclosure. Weathershields available to upgrade the enclosures to NEMA Type 3R (suitable for outdoor use). Standard transformers up through 75 kVA three-phase and 75 kVA single-phase can be mounted directly on wall via mounting brackets.

² Example of copper part number: EE75T3HCU

³ Contact your local Schneider Electric representative to obtain information about the 1000 kVA offering (part number, enclosure, wiring diagram, and weights).

Table 3: 600 V Delta Primary to 208Y/120 V Secondary

kVA	Part Number	Enclosure ¹ (Refer to pages 16–27)	Wiring Diagram	Weight (lbs)		°C Rise	Primary Current			Secondary Current	
				Al	Cu (Add CU suffix) ²		Nameplate	NEC Max Rating 125%	NEC Max Rating 250%	Nameplate	NEC Max Rating 125%
15	EE15T65H	17D	Figure 1 on page 28	220	310	150	14.5	25	35	41.7	60
30	EE30T65H	17D		260	340	150	28.9	40	70	83.4	110
45	EE45T65H	18D		320	372	150	43.4	60	100	125.1	175
75	EE75T65H	20D		410	527	150	72.3	100	175	208.4	275
112.5	EE112T65H	21D		620	725	150	108.4	150	250	312.6	400
150	EE150T65H	22D		800	920	150	144.5	200	350	416.9	500
225	EE225T65H	24D		1110	1090	150	216.8	275	500	625.3	800
300	EE300T65H	25D	1359	1535	150	289.0	400	700	833.7	1000	
500	EE500T79H	30D	Figure 2 on page 29	1870	2300	150	481.7	600	1200	1389.5	1600
750	EE750T79H	31D		3060	3710	150	722.5	900	1600	2084.3	2500
1000 ³	—	—	—	—	—	150	962.3	1200	2000	2775.7	3000

¹ NEMA Type 2 drip-proof enclosure. Weathershields available to upgrade the enclosures to NEMA Type 3R (suitable for outdoor use). Standard transformers up through 75 kVA three-phase and 75 kVA single-phase can be mounted directly on wall via mounting brackets.

² Example of copper part number: EE75T65HCU

³ Contact your local Schneider Electric representative to obtain information about the 1000 kVA offering (part number, enclosure, wiring diagram, and weights).

Energy Efficient Transformers Three-Phase Transformers

Table 4: 240 V Delta Primary to 208Y/120 V Secondary

kVA	Part Number	Enclosure ¹ (Refer to pages 16–27)	Wiring Diagram	Weight (lbs) Al	°C Rise	Primary Current			Secondary Current	
						Nameplate	NEC Max Rating 125%	NEC Max Rating 250%	Nameplate	NEC Max Rating 125%
15	EE15T67H	17D	Figure 1 on page 28	240	150	36.1	50	90	41.6	60
30	EE30T67H	17D		260	150	72.2	100	175	83.3	110
45	EE45T67H	18D		380	150	108.3	150	250	124.9	175
75	EE75T67H	20D		590	150	180.4	250	450	208.2	275
112.5	EE112T67H	21D		620	150	270.6	350	600	312.3	400
150	EE150T67H	22D		805	150	360.8	500	800	416.4	600
225	EE225T67H	24D		975	150	541.3	700	1200	624.5	800
300	EE300T67H	25D		1570	150	721.7	1000	1600	832.7	1200
500	EE500T239H	30D	Figure 7 on page 31	1870	150	1202.8	1600	3000	1387.9	2000
750	EE750T239H	31D		3010	150	1804.2	2500	4000	2081.8	3000

¹ NEMA Type 2 drip-proof enclosure. Weathershields available to upgrade the enclosures to NEMA Type 3R (suitable for outdoor use). Standard transformers up through 75 kVA three-phase and 75 kVA single-phase can be mounted directly on wall via mounting brackets.

Table 5: 208 V Delta Primary to 208Y/120 V Secondary

kVA	Part Number	Enclosure ¹ Refer to pages 16–27)	Wiring Diagram	Weight (lbs) Al	°C Rise	Primary Current			Secondary Current	
						Nameplate	NEC Max Rating 125%	NEC Max Rating 250%	Nameplate	NEC Max Rating 125%
15	EE15T211H	17D	Figure 7 on page 31	210	150	41.6	60	100	41.6	60
30	EE30T211H	17D		260	150	83.3	110	200	83.3	110
45	EE45T211H	18D		375	150	124.9	175	300	124.9	175
75	EE75T211H	20D		450	150	208.2	275	500	208.2	275
112.5	EE112T211H	21D		605	150	312.3	400	700	312.3	400
150	EE150T211H	22D		800	150	416.4	600	1000	416.4	600
225	EE225T211H	24D		1000	150	624.5	800	1200	624.5	800
300	EE300T211H	25D		1425	150	832.7	1200	2000	832.7	1200
500	EE500T211H	30D		1870	150	1387.9	2000	3000	1387.9	2000
750	EE750T211H	31D		3000	150	2081.8	3000	5000	2081.8	3000

¹ NEMA Type 2 drip-proof enclosure. Weathershields available to upgrade the enclosures to NEMA Type 3R (suitable for outdoor use). Standard transformers up through 75 kVA three-phase and 75 kVA single-phase can be mounted directly on wall via mounting brackets.

Energy Efficient Transformers

Three-Phase Transformers

Table 6: 480 V Delta Primary to 480Y/277 V Secondary

kVA	Part Number	Enclosure ¹ (Refer to pages 16–27)	Wiring Diagram	Weight (lbs) Al	°C Rise	Primary Current			Secondary Current	
						Nameplate	NEC Max Rating 125%	NEC Max Rating 250%	Nameplate	NEC Max Rating 125%
15	EE15T1814H	17D	Figure 1 on page 28	220	150	18.0	25	45	18.0	25
30	EE30T1814H	17D		260	150	36.1	45	90	36.1	45
45	EE45T1814H	18D		320	150	54.2	70	125	54.2	70
75	EE75T1814H	20D		410	150	90.3	125	225	90.3	125
112.5	EE112T1814H	21D		620	150	135.5	175	300	135.5	175
150	EE150T1814H	22D		800	150	180.6	225	450	180.6	225
225	EE225T1814H	24D		1110	150	271.0	300	600	271.0	300
300	EE300T1814H	25D		1359	150	361.3	450	900	361.3	450
500	EE500T76H	30D	Figure 2 on page 29	1870	150	602.1	800	1500	602.1	800
750	EE750T76H	31D		3060	150	903.2	1000	2000	903.2	1000

¹ NEMA Type 2 drip-proof enclosure. Weathershields available to upgrade the enclosures to NEMA Type 3R (suitable for outdoor use). Standard transformers up through 75 kVA three-phase and 75 kVA single-phase can be mounted directly on wall via mounting brackets.

Table 7: 208 V Delta Primary to 480Y/277 V Secondary

kVA	Part Number	Enclosure ¹ (Refer to pages 16–27)	Wiring Diagram	Weight (lbs) Al	°C Rise	Primary Current			Secondary Current	
						Nameplate	NEC Max Rating 125%	NEC Max Rating 250%	Nameplate	NEC Max Rating 125%
15	EE15T212H	17D	Figure 6 on page 31	220	150	41.7	60	100	18.0	25
30	EE30T212H	17D		260	150	83.4	110	200	36.1	45
45	EE45T212H	18D		320	150	125.1	175	300	54.2	70
75	EE75T212H	20D		410	150	208.4	275	500	90.3	125
112.5	EE112T212H	21D		620	150	312.6	400	700	135.5	175
150	EE150T212H	22D		800	150	416.9	600	1000	180.6	225
225	EE225T212H	24D		1110	150	625.3	800	1200	271.0	300
300	EE300T212H	25D		1359	150	833.7	1200	2000	361.3	450
500	EE500T212H	30D		1870	150		2000	3000	602.1	800
750	EE750T212H	31D		3060	150		3000	5000	903.2	1000

¹ NEMA Type 2 drip-proof enclosure. Weathershields available to upgrade the enclosures to NEMA Type 3R (suitable for outdoor use). Standard transformers up through 75 kVA three-phase and 75 kVA single-phase can be mounted directly on wall via mounting brackets.

Energy Efficient Transformers Three-Phase Transformers

Table 8: 480 V Delta Primary to 240 V Delta Secondary

kVA	Part Number	Enclosure ¹ (Refer to pages 16–27)	Wiring Diagram	Weight (lbs) Al	°C Rise	Primary Current			Secondary Current	
						Nameplate	NEC Max Rating 125%	NEC Max Rating 250%	Nameplate	NEC Max Rating 125%
15	EE15T6H	17D	Figure 3 on page 30	240	150	18.0	25	45	36.1	50
30	EE30T6H	17D		260	150	36.1	45	90	72.2	100
45	EE45T6H	18D		380	150	54.2	70	125	108.3	150
75	EE75T6H	20D		590	150	90.3	125	225	180.4	250
112.5	EE112T6H	21D		620	150	135.5	175	300	270.6	350
150	EE150T6H	22D		805	150	180.6	225	450	360.8	500
225	EE225T6H	24D		975	150	271.0	300	600	541.3	700
300	EE300T6H	25D	1570	150	361.3	450	900	721.7	1000	
500	EE500T63H	30D	Figure 4 on page 30	1870	150	602.1	800	1500	1202.8	1600
750	EE750T63H	31D		3010	150	903.2	1000	2000	1804.2	2500

¹ NEMA Type 2 drip-proof enclosure. Weathershields available to upgrade the enclosures to NEMA Type 3R (suitable for outdoor use). Standard transformers up through 75 kVA three-phase and 75 kVA single-phase can be mounted directly on wall via mounting brackets.

Table 9: 480 V Delta Primary to 380Y/220 V Delta Secondary

kVA	Part Number	Enclosure ¹ (Refer to pages 16–27)	Wiring Diagram	Weight (lbs) Al	°C Rise	Primary Current			Secondary Current	
						Nameplate	NEC Max Rating 125%	NEC Max Rating 250%	Nameplate	NEC Max Rating 125%
15	EE15T1755H	17D	Figure 1 on page 28	210	150	46.1	60	100	22.8	25
30	EE30T1755H	17D		260	150	83.3	110	200	45.6	50
45	EE45T1755H	18D		375	150	124.9	175	300	68.5	70
75	EE75T1755H	20D		450	150	208.2	275	500	114.1	125
112.5	EE112T1755H	21D		605	150	312.3	400	700	171.1	175
150	EE150T1755H	22D		800	150	416.4	600	1000	228.2	250
225	EE225T1755H	24D		1000	150	624.5	800	1200	342.3	350
300	EE300T1755H	25D	1425	150	832.7	1200	2000	456.3	500	
500	EE500T96H	30D	Figure 2 on page 29	1870	150	1387.9	2000	3000	760.3	800
750	EE750T96H	31D		3000	150	2081.8	3000	5000	1140.9	1200

¹ NEMA Type 2 drip-proof enclosure. Weathershields available to upgrade the enclosures to NEMA Type 3R (suitable for outdoor use). Standard transformers up through 75 kVA three-phase and 75 kVA single-phase can be mounted directly on wall via mounting brackets.

240/120 Four-Wire Delta Connection Transformers

Applications

240 Delta transformers with 120 center taps (CTs) have historically been limited to 5–10% capacity. This limit normally meets new installation requirements since the center tap is used for deriving a ground and/or maintenance for 120 loads (small load of lights and outlets around the 240 distribution panel).

However, for retrofit applications where the utility company or customers upgrade their systems from a 240/120 high leg system to a 480Y/277 system—existing 240/120 panels still need to be fed. In this case, the 5–10% 120 capacity does not meet upgrade requirements.

Possible solutions in the past have been to:

- Separate the 120 into a single-phase panel and the 240 into a three-phase panel.
- Use two single-phase transformers in open Delta.
- Have a special three-phase Wye to Delta transformer manufactured.

New Standard Offering

A three-phase Wye to Delta transformer is now a Square D® standard product offering from Schneider Electric.

Product Description:

- 480 Y Primary, 240 Delta with 120 center tap Secondary, 30 °C phase shift between Primary and Secondary
- Sizing of transformer is based on 120 V requirements and 240 V requirements (not limited to 5%)

Use the following formula to size the units.

— $(2.5 \times 120 \text{ single-phase loads}) + \text{balance } 240 \text{ three-phase loads} = \text{kVA required}$

— **Example:** 80 A of 120 V and 120 A of 240 balanced loads

$80 \times 120 = 9600 \text{ VA}$

$120 \times 240 \times 1.73 = 49,824 \text{ VA}$

$(2.5 \times 9600) + 49,824 = 73,824 \text{ VA} = 73.8 \text{ kVA}$

Use next standard size: 75 kVA

Table 10: 480 V to 240 Delta with 120 Center Tap (CT)

kVA	Part Number	Enclosure ¹ (Refer to pages 16–27)	Wiring Diagram	Weight (lbs) AI	°C Rise	Primary Current			Secondary Current	
						Nameplate	NEC Max Rating 125%	NEC Max Rating 250%	Nameplate	NEC Max Rating 125%
15	EE15T151HCT	17D	Figure 5 on page 31	220	150	18.0	25	45	36.1	50
30	EE30T151HCT	17D		260	150	36.1	45	90	72.2	100
45	EE45T151HCT	18D		320	150	54.2	70	125	108.3	150
75	EE75T151HCT	20D		410	150	90.3	125	225	180.4	250
112.5	EE112T151HCT	21D		620	150	135.5	175	300	270.6	350
150	EE150T151HCT	22D		800	150	180.6	225	450	360.8	500
225	EE225T151HCT	24D		1110	150	271.0	300	600	541.3	700
300	EE300T151HCT	25D		1359	150	361.3	450	900	721.7	1000
500	EE500T151HCT	30D		1870	150	602.1	800	1500	1202.8	1600
750	EE750T151HCT	31D		3060	150	903.2	1000	2000	1804.2	2500

Energy Efficient Transformers

240/120 Four-Wire Delta Connection Transformers

¹ NEMA Type 2 drip-proof enclosure. Weathershields available to upgrade the enclosures to NEMA Type 3R (suitable for outdoor use). Standard transformers up through 75 kVA three-phase and 75 kVA single-phase can be mounted directly on wall via mounting brackets.

Table 11: Standard Matrix: Loading—Sizing: 5, 10, and 15 Percent

5% 120 Loading—Sizing			10% 120 Loading—Sizing			15% 120 Loading—Sizing		
kVA	120 Loads	Balance 240 Loads	kVA	120 Loads	Balance 240 Loads	kVA	120 Loads	Balance 240 Loads
15	0.75	13.13	15	1.50	11.25	15	2.25	9.38
30	1.50	26.25	30	3.00	22.50	30	4.50	18.75
45	2.25	39.38	45	4.50	33.75	45	6.75	28.13
75	3.75	65.63	75	7.50	56.25	75	11.25	46.88
112.5	5.63	98.44	112.5	11.25	84.38	112.5	16.88	70.31
150	7.50	131.25	150	15.00	112.50	150	22.50	93.75
225	11.25	196.88	225	22.50	168.75	225	33.75	140.63
300	15.00	262.50	300	30.00	225.00	300	45.00	187.50
500	25.00	437.50	500	50.00	375.00	500	75.00	312.50
750	37.50	656.25	750	75.00	562.50	750	112.50	468.75

Table 12: Standard Matrix: Loading—Sizing: 20, 25, and 30 Percent

20% 120 Loading - Sizing			25% 120 Loading - Sizing			30% 120 Loading - Sizing		
kVA	120 Loads	Balance 240 Loads	kVA	120 Loads	Balance 240 Loads	kVA	120 Loads	Balance 240 Loads
15	3.00	7.50	15	3.75	5.63	15	4.50	3.75
30	6.00	15.00	30	7.50	11.25	30	9.00	7.50
45	9.00	22.50	45	11.25	16.88	45	13.50	11.25
75	15.00	37.50	75	18.75	28.13	75	22.50	18.75
112.5	22.50	56.25	112.5	28.13	42.19	112.5	33.75	28.13
150	30.00	75.00	150	37.50	56.25	150	45.00	37.50
225	45.00	112.50	225	56.25	84.38	225	67.50	56.25
300	60.00	150.00	300	75.00	112.50	300	90.00	75.00
500	100.00	250.00	500	125.00	187.50	500	150.00	125.00
750	150.00	375.00	750	187.50	281.25	750	225.00	187.50

Using the Matrix Tables

(1) Determine 240 V balance three-phase load.
$(240 \times \text{amps} \times 1.73) / 1000 = \text{kVA}$
Go to the next standard size (used in step (3))
(2) Determine 120 V single-phase load.
$(120 \times \text{amps}) / 1000 = \text{kVA}$
(3) Divide the answer from (2) by the standard kVA from (1) to obtain % 120 loading.
(4) Check the table above and below % of 120 loading. Verify the three-phase kVA will be met with standard kVA.
Using Table
(1) Size three-phase load: 49.9 kVA: Next higher size 75 kVA
(2) Size single-phase load: 9.6 kVA
(3) $9.6 / 75 = 12.8\%$
Check the 10% and 15% for three-phase capacity on 75 kVA:
10% >> 56.25 kVA for 240 balance three phase
15% >> 46.88 kVA for 240 balance three phase
75 kVA will work for the application using the tables.

Energy Efficient Transformers

Single-Phase Transformers

Single-Phase Transformers

Refer to Tables 13 and 14 for single-phase transformer information.

Table 13: 240 x 480 V Primary to 120/240 V Secondary

kVA	Part Number	Enclosure ¹ (Refer to pages 16–23)	Wiring Diagram	Weight (lbs)		°C Rise	Primary Current			Primary Current			Secondary Current			
							480 Vac			240 Vac			240 Vac or 120/240 Vac		120 Vac	
				Al	Cu (Add CU suffix) ²		Nameplate	NEC Max Rating 125%	NEC Max Rating 250%	Nameplate	NEC Max Rating 125%	NEC Max Rating 250%	Nameplate	NEC Max Rating 125%	Nameplate	NEC Max Rating 125%
15	EE15S3H	17D	Figure 8 on page 32	215	300	150	31.3	40	70	62.5	80	150	62.5	80	125.0	175
25	EE25S3H	17H		285	380	150	52.1	70	125	104.2	150	250	104.2	150	208.3	275
37.5	EE37S3H	18H		340	380	150	78.1	100	175	156.3	200	350	156.3	200	312.5	400
50	EE50S3H	18H		395	460	150	104.2	150	250	208.3	275	500	208.3	275	416.7	500
75	EE75S3H	21D		619	650	150	156.3	200	350	312.5	400	700	312.5	400	625.0	800
100	EE100S3H	22D		682	825	150	208.3	275	500	416.7	500	1000	416.7	500	833.3	1000
167	EE167S3H	24D		982	1190	150	347.9	450	800	695.8	800	1600	695.8	800	1391.7	1600
250 ³	EE250S3H	—		—	—	150	520.8	700	1200	1041.7	1200	2500	1041.7	1200	2083.3	2500
333 ⁴	—	—	—	—	150	693.8	800	1600	1387.5	1600	3000	1387.5	1600	2775.0	3000	

¹ NEMA Type 2 drip-proof enclosure. Weathershields available to upgrade the enclosures to NEMA Type 3R (suitable for outdoor use). Standard transformers up through 75 kVA three-phase and 75 kVA single-phase can be mounted directly on wall via mounting brackets.

² Example of copper part number: EE50S3HCU

³ Contact your local Schneider Electric representative to obtain information about the 250 kVA single-phase offering (enclosure and weights).

⁴ Contact your local Schneider Electric representative to obtain information about the 333 kVA single-phase offering (part number, enclosure, wiring diagram, and weights).

Table 14: 600 V Primary to 120/240 V Secondary

kVA	Part Number	Enclosure ¹ (Refer to pages 16–23)	Wiring Diagram	Weight (lbs)		°C Rise	Primary Current			Secondary Current			
							240 Vac or 120/240 Vac			120 Vac			
				Al	Cu (Add CU suffix) ²		Nameplate	NEC Max Rating 125%	NEC Max Rating 250%	Nameplate	NEC Max Rating 125%	Nameplate	NEC Max Rating 125%
15	EE15S3534H	17D	Figure 9 on page 32	215	300	150	25.0	35	60	62.5	80	125.0	175
25	EE25S3534H	17H		285	380	150	41.7	60	100	104.2	150	208.3	275
37.5	EE37S3534H	18H		340	380	150	62.5	80	150	156.3	200	312.5	400
50	EE50S3534H	18H		395	460	150	83.3	110	200	208.3	275	416.7	500
75	EE75S3534H	21D		619	650	150	125.0	175	300	312.5	400	625.0	800
100	EE100S3534H	22D		682	825	150	166.7	225	400	416.7	500	833.3	1000
167	EE167S3534H	24D		982	1190	150	278.3	350	600	695.8	800	1391.7	1600
250 ³	EE250S3534H	—		—	—	150	416.7	500	1000	1041.7	1200	2083.3	2500
333 ⁴	—	—	—	—	150	555.0	700	1200	1387.5	1600	2775.0	3000	

¹ NEMA Type 2 drip-proof enclosure. Weathershields available to upgrade the enclosures to NEMA Type 3R (suitable for outdoor use). Standard transformers up through 75 kVA three-phase and 75 kVA single-phase can be mounted directly on wall via mounting brackets.

² Example of copper part number: EE50S3534HCU

³ Contact your local Schneider Electric representative to obtain information about the 250 kVA single-phase offering (enclosure and weights).

⁴ Contact your local Schneider Electric representative to obtain information about the 333 kVA single-phase offering (part number, enclosure, wiring diagram, and weights).

Non-Linear Energy Efficient Transformers

Type NL and NLP are dry-type transformers intended to supply power to applications such as computers, copiers, printers, FAX machines, video display terminals, and other equipment having switched-mode power supplies. The standard type NL model and the premium type NLP model are built to handle high current distortion harmonics associated with such loads. The NLP transformer is designed particularly for more severe non-linear load applications.

General Features

- Three-phase dry-type transformers, 480 Delta—208Y/120
- Aluminum or copper windings
- Electrostatic shield
- Class 220 insulation
- Double size neutral terminal for additional customer neutral cables
- Additional coil capacity to compensate for higher non-linear load loss
- cULus Listed

Table 15: 480 V Delta Primary to 208Y/120 Secondary—K-4 Rated—Aluminum Windings; 115° C Rise

kVA	Part Number (Al)	Enclosure (Refer to pages 16–27)	Wiring Diagram	Weight (lbs)		°C Rise	Primary Current			Secondary Current	
				Al	Cu (Add CU before NL) ¹		Nameplate	NEC Max Rating 125%	NEC Max Rating 250%	Nameplate	NEC Max Rating 125%
15	EE15T3HFISNL	17D	Figure 1 on page 28	256	260	115	18.0	25	45	41.7	60
30	EE30T3HFISNL	18D		320	430	115	36.1	45	90	83.4	110
45	EE45T3HFISNL	20D		600	730	115	54.2	70	125	125.1	175
75	EE75T3HFISNL	21D		535	490	115	90.3	125	225	208.4	275
112.5	EE112T3HFISNL	22D		800	900	115	135.5	175	300	312.6	400
150	EE150T3HFISNL	24D		1110	1120	115	180.6	225	450	416.9	500
225	EE225T3HFISNL	25D		1349	1477	115	271.0	300	600	625.3	800
300	EE300T68HFISNL	30D	Figure 2 on page 29	1880	1880	115	361.3	450	900	833.7	1000
500	EE500T68HFISNL	31D		2295	2625	115	602.1	800	1500	1389.5	1600

¹ Example of copper part number: EE75T3HFISCUNL

Table 16: 480 V Delta Primary to 208Y/120 Secondary—K-13 Rated—Aluminum Windings; 115° C Rise

kVA	Part Number (Al)	Enclosure (Refer to pages 16–27)	Wiring Diagram	Weight (lbs)		°C Rise	Primary Current			Secondary Current	
				Al	Cu (Add CU before NL) ¹		Nameplate	NEC Max Rating 125%	NEC Max Rating 250%	Nameplate	NEC Max Rating 125%
15	EE15T3HFISNLP	17D	Figure 1 on page 28	256	260	115	18.0	25	45	41.7	60
30	EE30T3HFISNLP	18D		375	430	115	36.1	45	90	83.4	110
45	EE45T3HFISNLP	20D		500	730	115	54.2	70	125	125.1	175
75	EE75T3HFISNLP	21D		560	640	115	90.3	125	225	208.4	275
112.5	EE112T3HFISNLP	22D		800	985	115	135.5	175	300	312.6	400
150	EE150T3HFISNLP	24D		1110	1135	115	180.6	225	450	416.9	500
225	EE225T3HFISNLP	25D		1335	1477	115	271.0	300	600	625.3	800
300	EE300T68HFISNLP	30D	Figure 2 on page 29	1898	1895	115	361.3	450	900	833.7	1000
500	EE500T68HFISNLP	31D		3200	2625	115	602.1	800	1500	1389.5	1600

¹ Example of copper part number: EE75T3HFISCUNLP

Energy Efficient Transformers

Watchdog® Low Temperature Rise Transformers

Watchdog® Low Temperature Rise Transformers

Watchdog® transformers are designed to maximize energy efficiency and supplies the highest efficient levels for 24-hour loading greater than 50 percent. Their extra long life expectancy using a 220 °C insulation system is designed for full load operation at a maximum temperature rise of 115 °C or 80 °C instead of 150 °C. Continuous emergency overload capability is used for 15 percent on 115 °C rise and 30 percent on 80 °C rise. These transformers meet the efficiency standards in *The Guide for Determining Energy Efficiency for Distribution Transformers*, published by the NEMA (NEMA TP1–2002).

Three-Phase

Table 17: 115 °C Rise 480 V Delta Primary to 208Y/120 Secondary

kVA	Part Number (AI)	Enclosure ¹ (Refer to pages 16–27)	Wiring Diagram	Weight (lbs)		°C Rise	Primary Current			Secondary Current	
				Al	Cu (Add CU Suffix) ²		Nameplate	NEC Max Rating 125%	NEC Max Rating 250%	Nameplate	NEC Max Rating 125%
15	EE15T3HF	17D	Figure 1 on page 28	260	340	115	18.0	25	45	41.7	60
30	EE30T3HF	18D		320	372	115	36.1	45	90	83.4	110
45	EE45T3HF	20D		410	527	115	54.2	70	125	125.1	175
75	EE75T3HF	21D		620	725	115	90.3	125	225	208.4	275
112.5	EE112T3HF	22D		800	920	115	135.5	175	300	312.6	400
150	EE150T3HF	24D		1110	1090	115	180.6	225	450	416.9	500
225	EE225T3HF	25D		1359	1535	115	271.0	300	600	625.3	800
300	EE300T68HF	30D	Figure 2 on page 29	1870	2300	115	361.3	450	900	833.7	1000
500	EE500T68HF	31D		3060	3710	115	602.1	800	1500	1389.5	1600

¹ NEMA Type 2 drip-proof enclosure. Weathershields available to upgrade the enclosures to NEMA Type 3R (suitable for outdoor use). Standard transformers up through 45 kVA three-phase and 45 kVA single-phase can be mounted directly on wall via mounting brackets.

² Example of copper part number: EE75T3HFCU

Table 18: 80° C Rise 480 V Delta Primary to 208Y/120 Secondary

kVA	Part Number (AI)	Enclosure ¹ (Refer to pages 16–27)	Wiring Diagram	Weight (lbs)		°C Rise	Primary Current			Secondary Current	
				Al	Cu (Add CU Suffix) ²		Nameplate	NEC Max Rating 125%	NEC Max Rating 250%	Nameplate	NEC Max Rating 125%
15	EE15T3HB	17D	Figure 1 on page 28	260	340	80	18.0	25	45	41.7	60
30	EE30T3HB	18D		320	372	80	36.1	45	90	83.4	110
45	EE45T3HB	20D		410	527	80	54.2	70	125	125.1	175
75	EE75T3HB	21D		620	725	80	90.3	125	225	208.4	275
112.5	EE112T3HB	22D		800	920	80	135.5	175	300	312.6	400
150	EE150T3HB	24D		1110	1090	80	180.6	225	450	416.9	500
225	EE225T3HB	25D		1359	1535	80	271.0	300	600	625.3	800
300	EE300T68HB	30D	Figure 2 on page 29	1870	2300	80	361.3	450	900	833.7	1000
500	EE500T68HB	31D		3060	3710	80	602.1	800	1500	1389.5	1600

¹ NEMA Type 2 drip-proof enclosure. Weathershields available to upgrade the enclosures to NEMA Type 3R (suitable for outdoor use). Standard transformers up through 45 kVA three-phase and 45 kVA single-phase can be mounted directly on wall via mounting brackets.

² Example of copper part number: EE75T3HBCU

Single-Phase Transformers

Table 19: 115 °C Rise 240 x 480 V Primary to 120/240 V Secondary

kVA	Part Number (Al)	Enclosure ¹ (Refer to pages 17–23)	Wiring Diagram	Weight (lbs) Al	Cu (Add CU Suffix) ²	°C Rise	Primary Current			Primary Current			Secondary Current			
							240 V			480 V			120 V		240 V	
							Nameplate	NEC Max Rating 125%	NEC Max Rating 250%	Nameplate	NEC Max Rating 125%	NEC Max Rating 250%	Nameplate	NEC Max Rating 125%	Nameplate	NEC Max Rating 125%
15	EE15S3HF	17H	Figure 8 on page 32	275	375	115	31.3	40	70	62.5	80	150	62.5	80	125.0	175
25	EE25S3HF	18H		340	395	115	52.1	70	125	104.2	150	250	104.2	150	208.3	275
37.5	EE37S3HF	18H		420	465	115	78.1	100	175	156.3	200	350	156.3	200	312.5	400
50	EE50S3HF	21D		620	660	115	104.2	150	250	208.3	275	500	208.3	275	416.7	500
75	EE75S3HF	22D		795	890	115	156.3	200	350	312.5	400	700	312.5	400	625.0	800
100	EE100S3HF	24D		945	1075	115	208.3	275	500	416.7	500	1000	416.7	500	833.3	1000
167	EE167S3HF	25D		1120	—	115	347.9	450	800	695.8	800	1600	695.8	800	1391.7	1600

¹ NEMA Type 2 drip-proof enclosure. Weathershields available to upgrade the enclosures to NEMA Type 3R (suitable for outdoor use). Standard transformers up through 45 kVA three-phase and 45 kVA single-phase can be mounted directly on wall via mounting brackets.

² Example of copper part number: EE50S3HFCU

Table 20: 80 °C Rise 240 x 480 V Primary to 120/240 V Secondary

kVA	Part Number (Al)	Enclosure ¹ (Refer to pages 17–23)	Wiring Diagram	Weight (lbs) Al	Cu (Add CU Suffix) ²	°C Rise	Primary Current			Primary Current			Secondary Current			
							240 V			480 V			120 V		240 V	
							Nameplate	NEC Max Rating 125%	NEC Max Rating 250%	Nameplate	NEC Max Rating 125%	NEC Max Rating 250%	Nameplate	NEC Max Rating 125%	Nameplate	NEC Max Rating 125%
15	EE15S3HB	17H	Figure 8 on page 32	275	375	80	31.3	40	70	62.5	80	150	62.5	80	125.0	175
25	EE25S3HB	18H		340	395	80	52.1	70	125	104.2	150	250	104.2	150	208.3	275
37.5	EE37S3HB	18H		420	465	80	78.1	100	175	156.3	200	350	156.3	200	312.5	400
50	EE50S3HB	21D		620	660	80	104.2	150	250	208.3	275	500	208.3	275	416.7	500
75	EE75S3HB	22D		795	890	80	156.3	200	350	312.5	400	700	312.5	400	625.0	800
100	EE100S3HB	24D		985	1075	80	208.3	275	500	416.7	500	1000	416.7	500	833.3	1000
167	EE167S3HB	25D		1120	—	80	347.9	450	800	695.8	800	1600	695.8	800	1391.7	1600

¹ NEMA Type 2 drip-proof enclosure. Weathershields available to upgrade the enclosures to NEMA Type 3R (suitable for outdoor use). Standard transformers up through 45 kVA three-phase and 45 kVA single-phase can be mounted directly on wall via mounting brackets.

² Example of copper part number: EE50S3HBCU

Made-To-Order Transformers

Schneider Electric manufactures made-to-order energy efficient transformers to meet the specific needs of particular applications and are designed for 60 hertz systems. The Square D® Transformer Product Selector allows the customer to derive part numbers for these applications.

Options that are supported via the Product Selector include:

- Winding material:
 - Standard aluminum
 - Optional copper
- Enclosure:
 - NEMA Type 2
 - NEMA Type 3R with field installed accessories
 - Open no enclosure: IP00
- Material:
 - Standard painted cold rolled steel
 - Optional painted 316 stainless steel
- Sound level (NEMA ST-20)

kVA	Standard dB	3 dB Below	6 dB Below
10–50	45	42	39
51–150	50	47	44
151–300	55	52	49
301–500	60	57	54
501–700	62	59	56
701–1000	64	61	58

- Temperature rise: 220 °C insulation
 - Standard 150 °C rise
 - Optional 115 °C rise or 80 °C rise
- Electrostatic shielding available on all units—installed between primary and secondary windings

Special Three-Phase Voltage Combinations

Refer to Table 21 for available special three-phase voltage combinations. The primary voltages are Delta configurations because they can be used on both three-wire and four-wire (Wye) systems.

Table 21: Three-Phase Voltage Combinations: Made-to-Order Transformers

Secondary Voltage	Primary Voltage				
	600 Delta	480 Delta	440 Delta	240 Delta	208 Delta
208Y/120 240 Delta 480Y/277 480 Delta	Primary: United States and Canada Secondary: North American Distribution	Primary: North America Secondary: North American Distribution	Primary: Mexico Secondary: North American Distribution	Primary: United States Secondary: North American Distribution	Primary: United States Secondary: North American Distribution
600 Delta 600Y/346	Primary: United States and Canada Secondary: Canadian Distribution	Primary: North America Secondary: Canadian Distribution	Primary: Mexico Secondary: Canadian Distribution	Primary: United States Secondary: Canadian Distribution	Primary: United States Secondary: Canadian Distribution
220Y/127	Primary: United States and Canada Secondary: Mexican Distribution	Primary: North America Secondary: Mexican Distribution	Primary: Mexico Secondary: Mexican Distribution	Primary: United States Secondary: Mexican Distribution	Primary: United States Secondary: Mexican Distribution
415Y/240 416Y/240 400Y/230 380Y/220	Primary: United States and Canada Secondary: Overseas Equipment	Primary: North America Secondary: Overseas Equipment	Primary: Mexico Secondary: Overseas Equipment	Primary: United States Secondary: Overseas Equipment	Primary: United States Secondary: Overseas Equipment

Special Single-Phase Voltage Combinations

Refer to Table 22 for available special single-phase voltage combinations.

Table 22: Single-Phase Voltage Combinations: Made-to-Order Transformers

Secondary Voltage	Primary Voltage							
	600	480	240	120	208	277	240 X 480	120 X 240
120/240	Primary: United States and Canada Secondary: 3-Wire Output, 120 Line-to-Neutral, 240 Line-to-Line, or 240 Line-to-Neutral	Primary: United States Secondary: 3-Wire Output, 120 Line-to-Neutral, 240 Line-to-Line, or 240 Line-to-Neutral						
208	Primary: United States & Canada Secondary: Line to Line 208 (No 120)	Primary: United States Secondary: Line-to-Line 208 (No 120)						
277	Primary: United States and Canada Secondary: Line-to-Neutral	Primary: United States Secondary: Line-to-Neutral						
480	Primary: United States and Canada Secondary: Line-to-Line 480	Primary: United States Secondary: Line-to-Line 480						
600	Primary: United States and Canada Secondary: Line-to-Line 600	Primary: United States Secondary: Line-to-Line 600						
200/400	Primary: United States and Canada Secondary: 200 Line-to-Line or 400 Line-to-Line (Overseas Equipment)	Primary: United States and Canada Secondary: 200 Line-to-Line or 400 Line-to-Line (Overseas Equipment)						
220	Primary: United States and Canada Secondary: Overseas Equipment Line-to-Line Voltages	Primary: United States & Canada Secondary: Overseas Equipment Line-to-Line Voltages						
230								
415								
416								
380								

Other voltages are available:

- 575 V: It is suggested to use 600 V as the system voltage.
- 460 V: It is suggested to use 480 V as the system voltage.

Export primary voltages include:

- 416 V, 415 V, 400 V, 380 V, and 200 V.

Enclosure Diagrams and Accessories

Enclosure Parts and Accessories

Refer to pages 16–27 for enclosure type and accessory information.

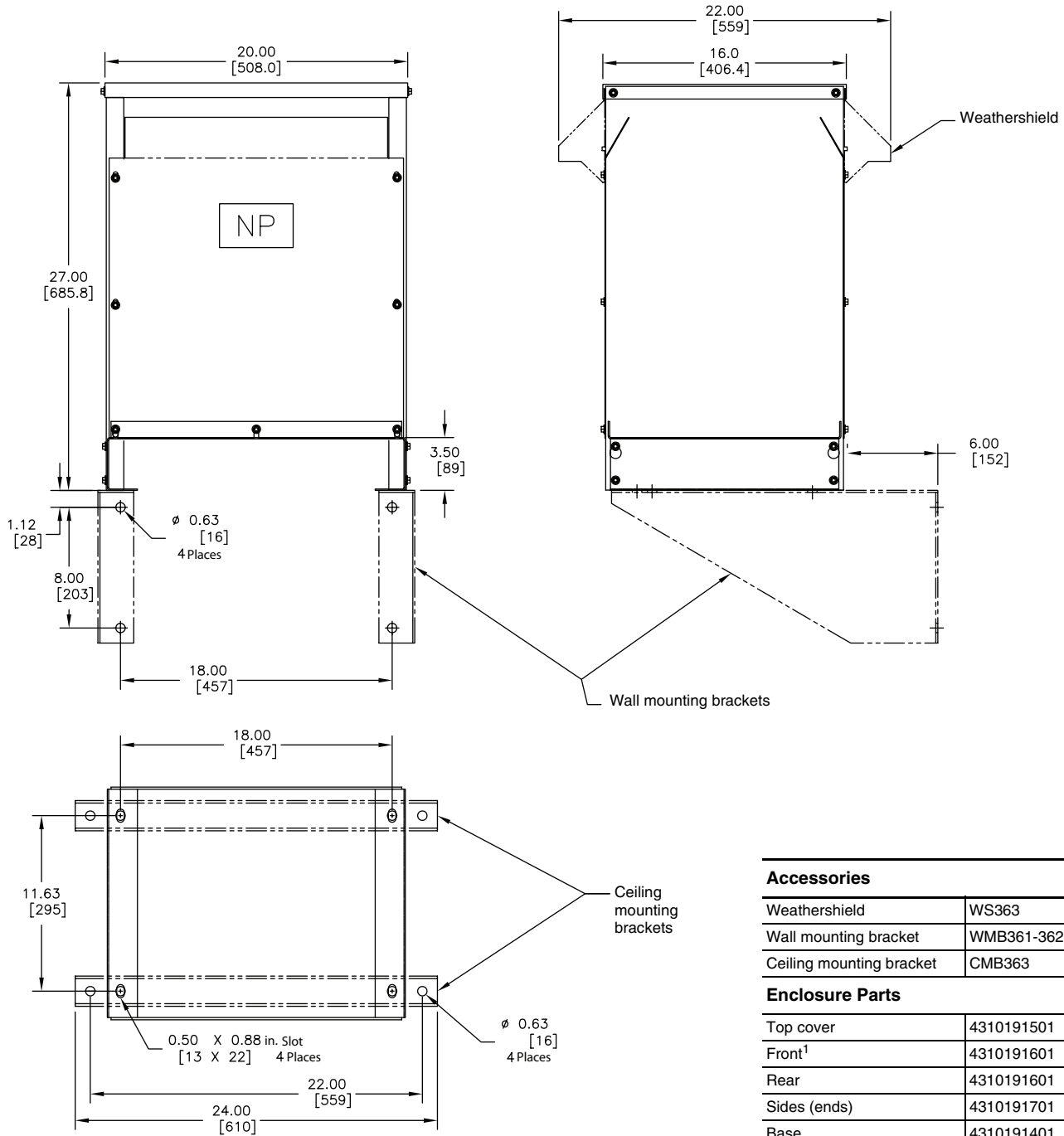

Accessories

Weathershield	WS363
Wall mounting bracket	WMB361-362
Ceiling mounting bracket	CMB363

Enclosure Parts

Top cover	4310191501
Front ¹	4310191601
Rear	4310191601
Sides (ends)	4310191701
Base	4310191401

¹ When replacing a front panel, specify the transformer part number and "with nameplate and labels" on the order.

Enclosure 17D—Dry-Type Transformer

Energy Efficient Transformers Enclosure Diagrams and Accessories

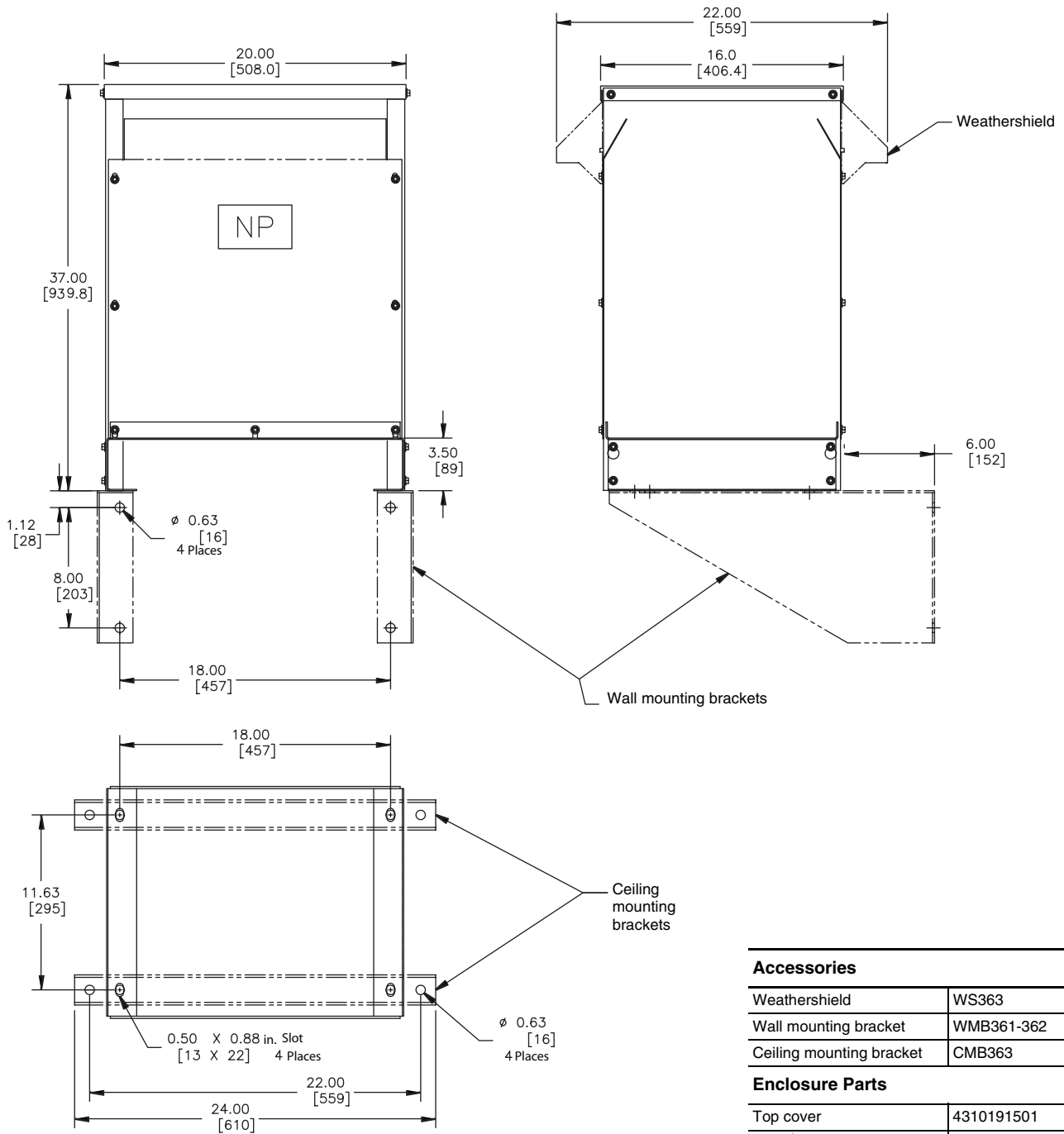

Accessories

Weathershield	WS363
Wall mounting bracket	WMB361-362
Ceiling mounting bracket	CMB363

Enclosure Parts

Top cover	4310191501
Front ¹	4305502003
Rear	4305502003
Sides (ends)	4310191702
Base	4310191401

¹ When replacing a front panel, specify the transformer part number and "with nameplate and labels" on the order.

Enclosure 17H—Dry-Type Transformer

Energy Efficient Transformers

Enclosure Diagrams and Accessories

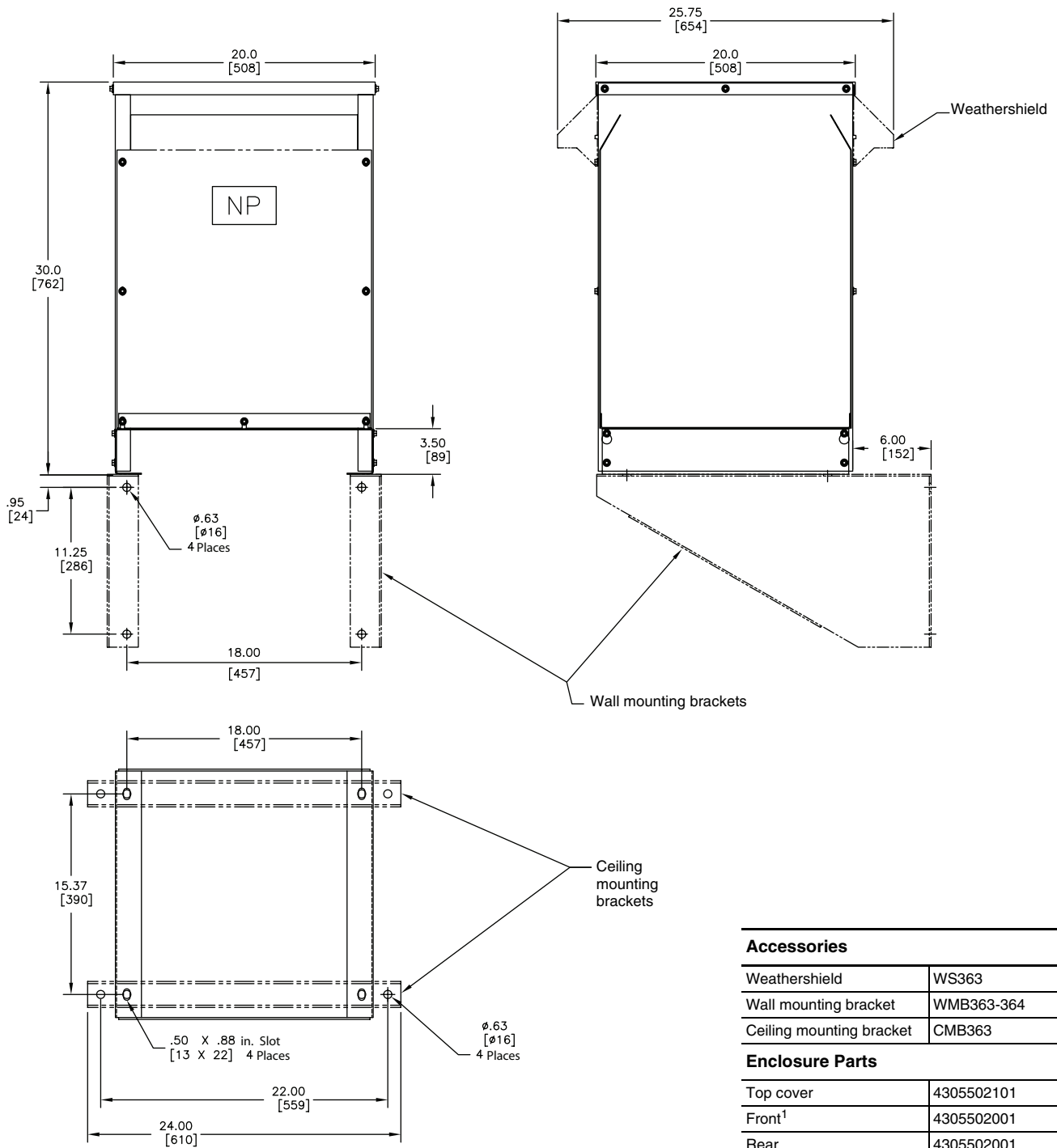

Accessories

Weathershield	WS363
Wall mounting bracket	WMB363-364
Ceiling mounting bracket	CMB363

Enclosure Parts

Top cover	4305502101
Front ¹	4305502001
Rear	4305502001
Sides (ends)	4305501001
Base	4305501801

¹ When replacing a front panel, specify the transformer part number and "with nameplate and labels" on the order.

Enclosure 18D—Dry-Type Transformer

Energy Efficient Transformers Enclosure Diagrams and Accessories

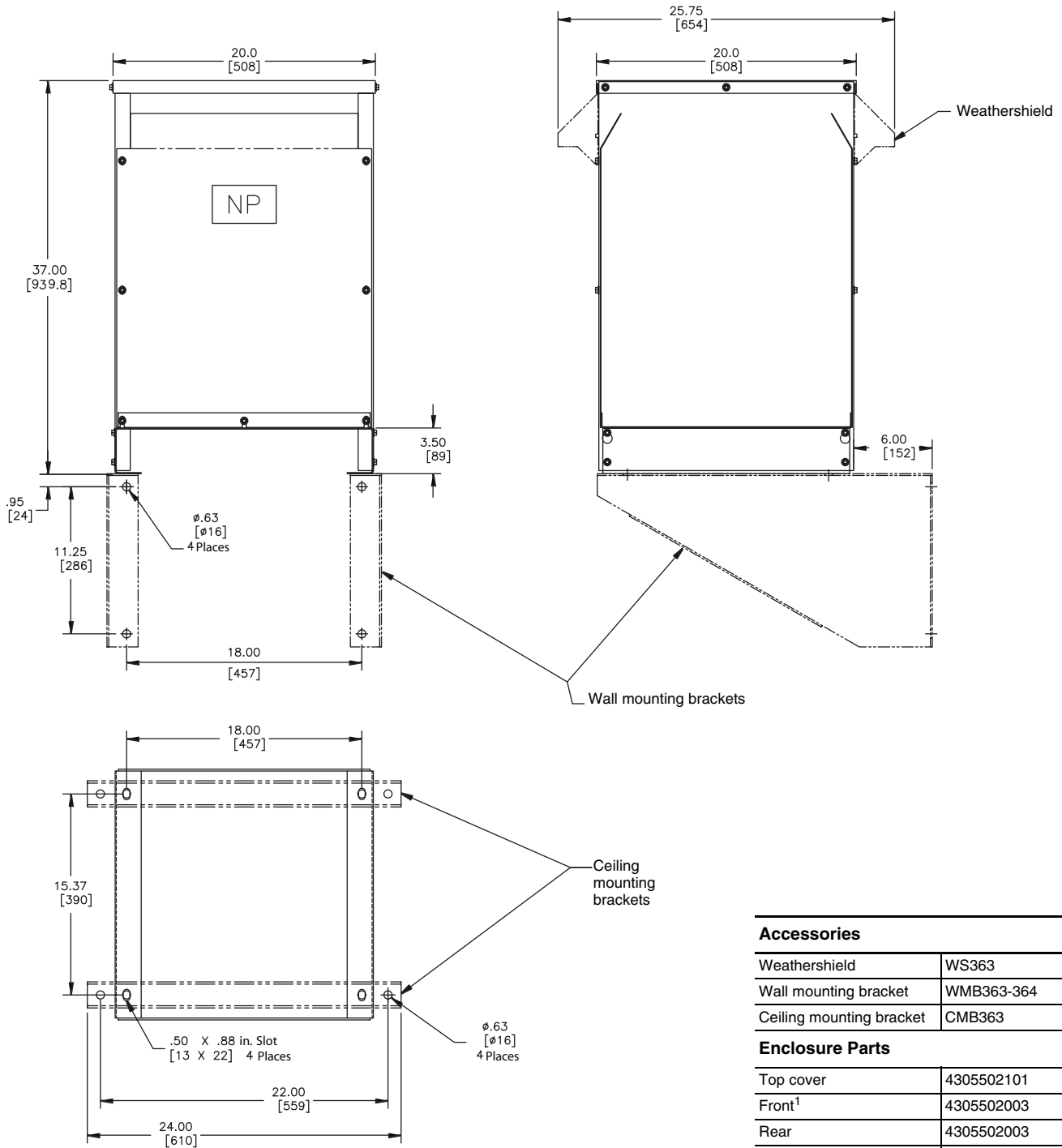

Accessories

Weathershield	WS363
Wall mounting bracket	WMB363-364
Ceiling mounting bracket	CMB363

Enclosure Parts

Top cover	4305502101
Front ¹	4305502003
Rear	4305502003
Sides (ends)	4310179701
Base	4305501801

¹ When replacing a front panel, specify the transformer part number and "with nameplate and labels" on the order.

Enclosure 18H—Dry-Type Transformer

Energy Efficient Transformers

Enclosure Diagrams and Accessories

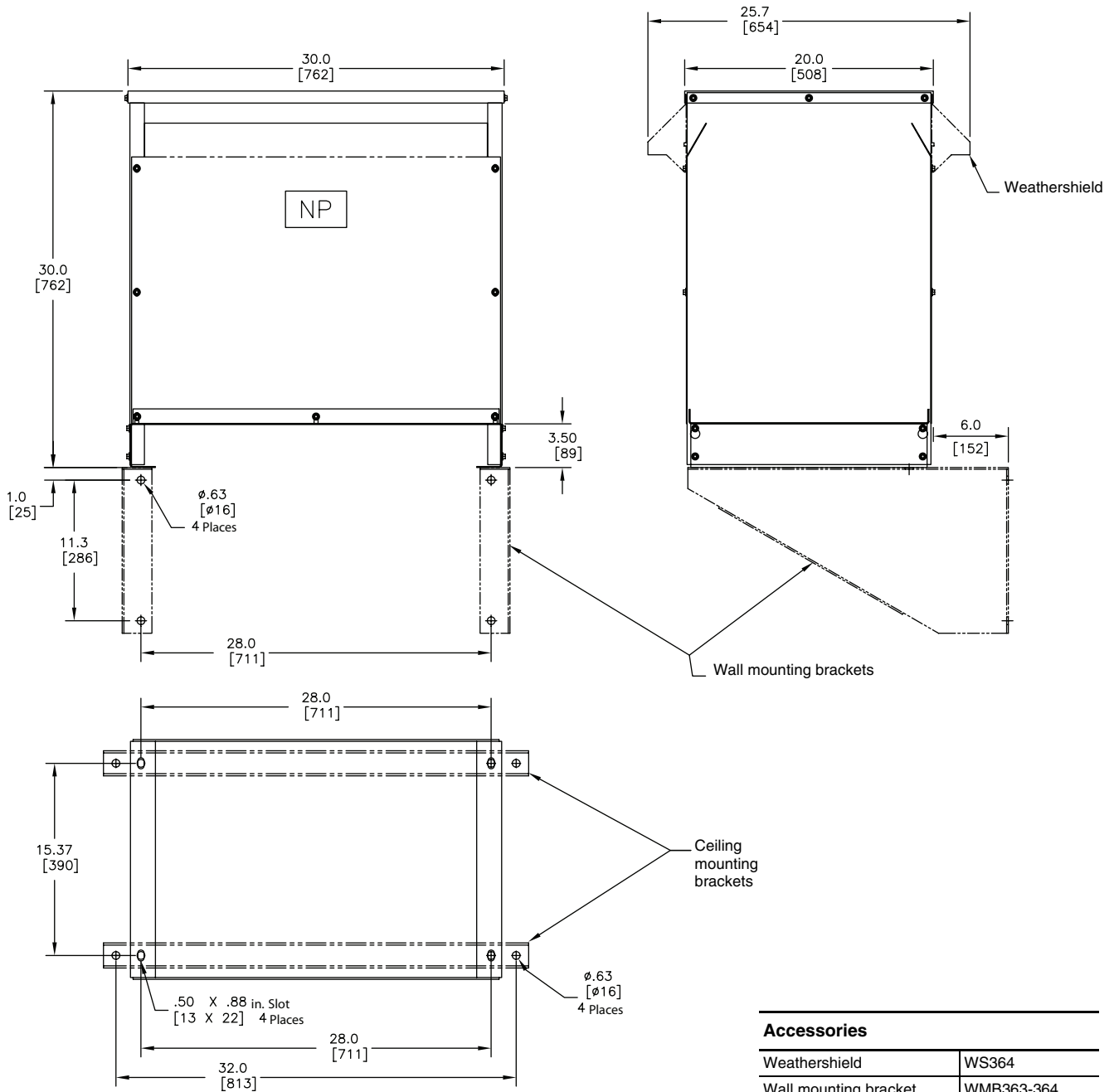

Accessories

Weathershield	WS364
Wall mounting bracket	WMB363-364
Ceiling mounting bracket	CMB364

Enclosure Parts

Top cover	4305501201
Front ¹	4305501101
Rear	4305501101
Sides (ends)	4305501001
Base	4305500901

¹ When replacing a front panel, specify the transformer part number and "with nameplate and labels" on the order.

Enclosure 19D—Dry-Type Transformer

Energy Efficient Transformers Enclosure Diagrams and Accessories

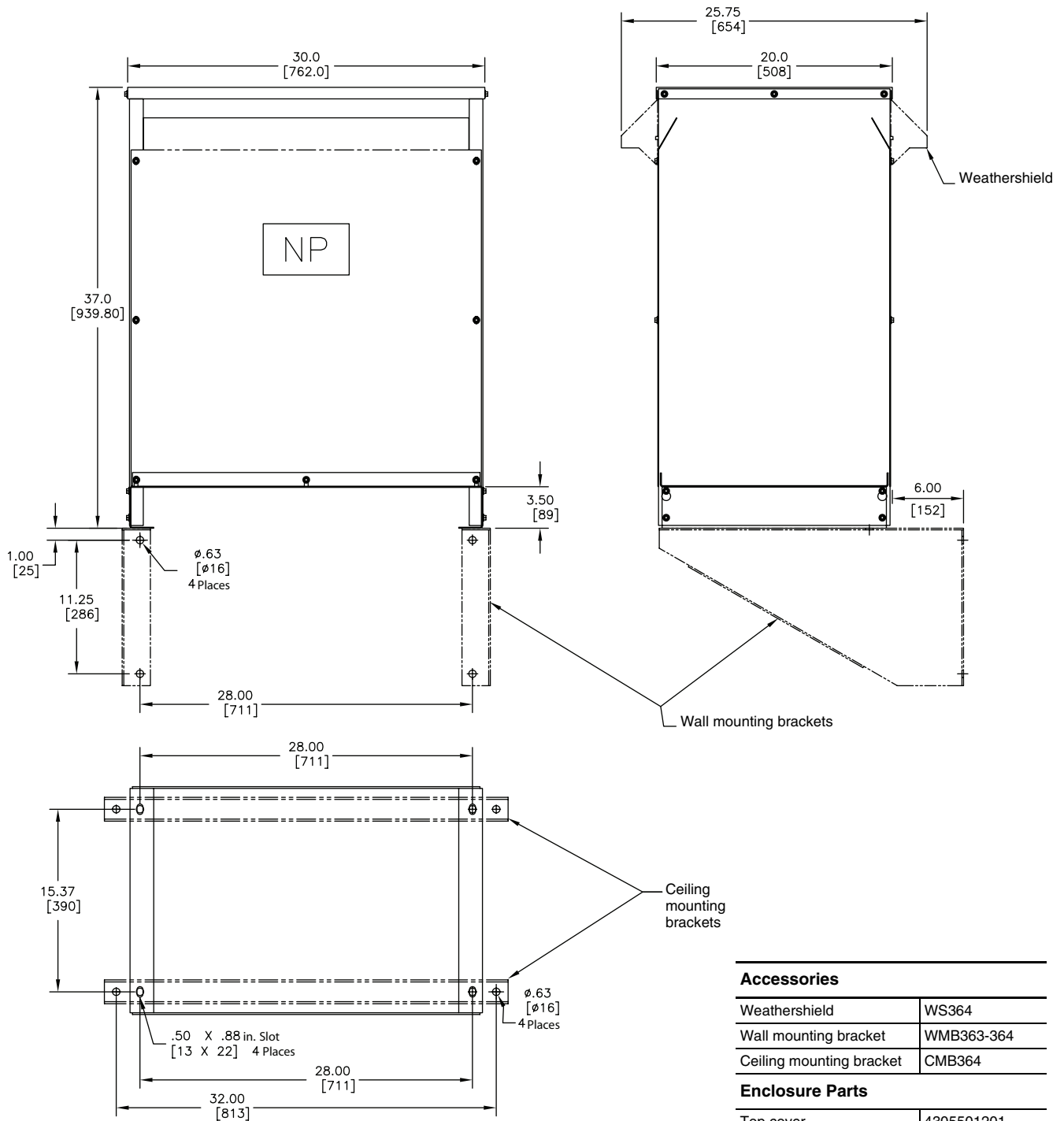

Accessories

Weathershield	WS364
Wall mounting bracket	WMB363-364
Ceiling mounting bracket	CMB364

Enclosure Parts

Top cover	4305501201
Front ¹	4310192201
Rear	4310192201
Sides (ends)	4310179701
Base	4305500901

¹ When replacing a front panel, specify the transformer part number and "with nameplate and labels" on the order.

Enclosure 20D—Dry-Type Transformer

Energy Efficient Transformers

Enclosure Diagrams and Accessories

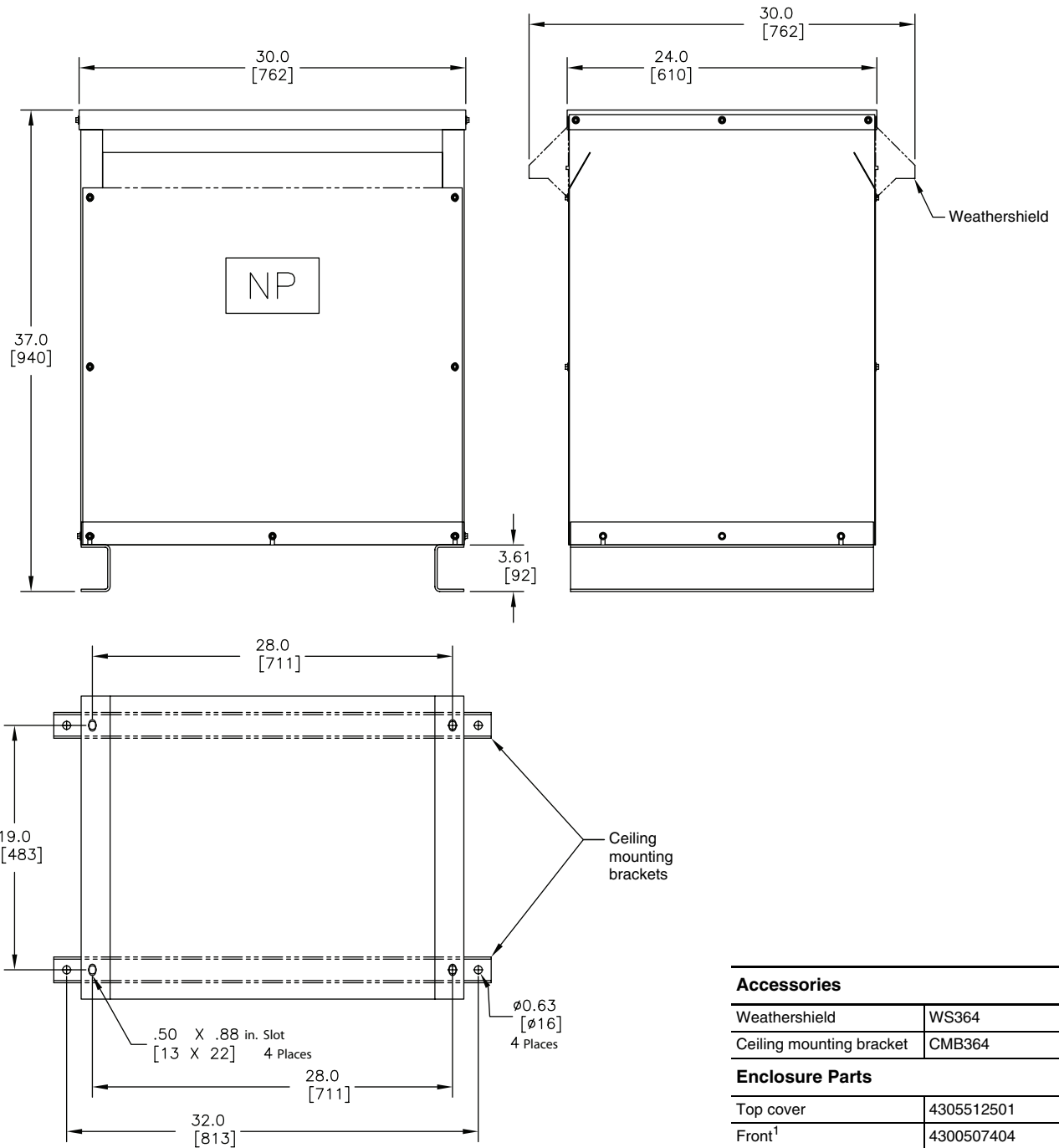

Accessories

Weathershield	WS364
Ceiling mounting bracket	CMB364

Enclosure Parts

Top cover	4305512501
Front ¹	4300507404
Rear	4300507404
Sides (ends)	4305512601
Base	4305512450

¹ When replacing a front panel, specify the transformer part number and "with nameplate and labels" on the order.

Enclosure 21D—Dry-Type Transformer

Energy Efficient Transformers Enclosure Diagrams and Accessories

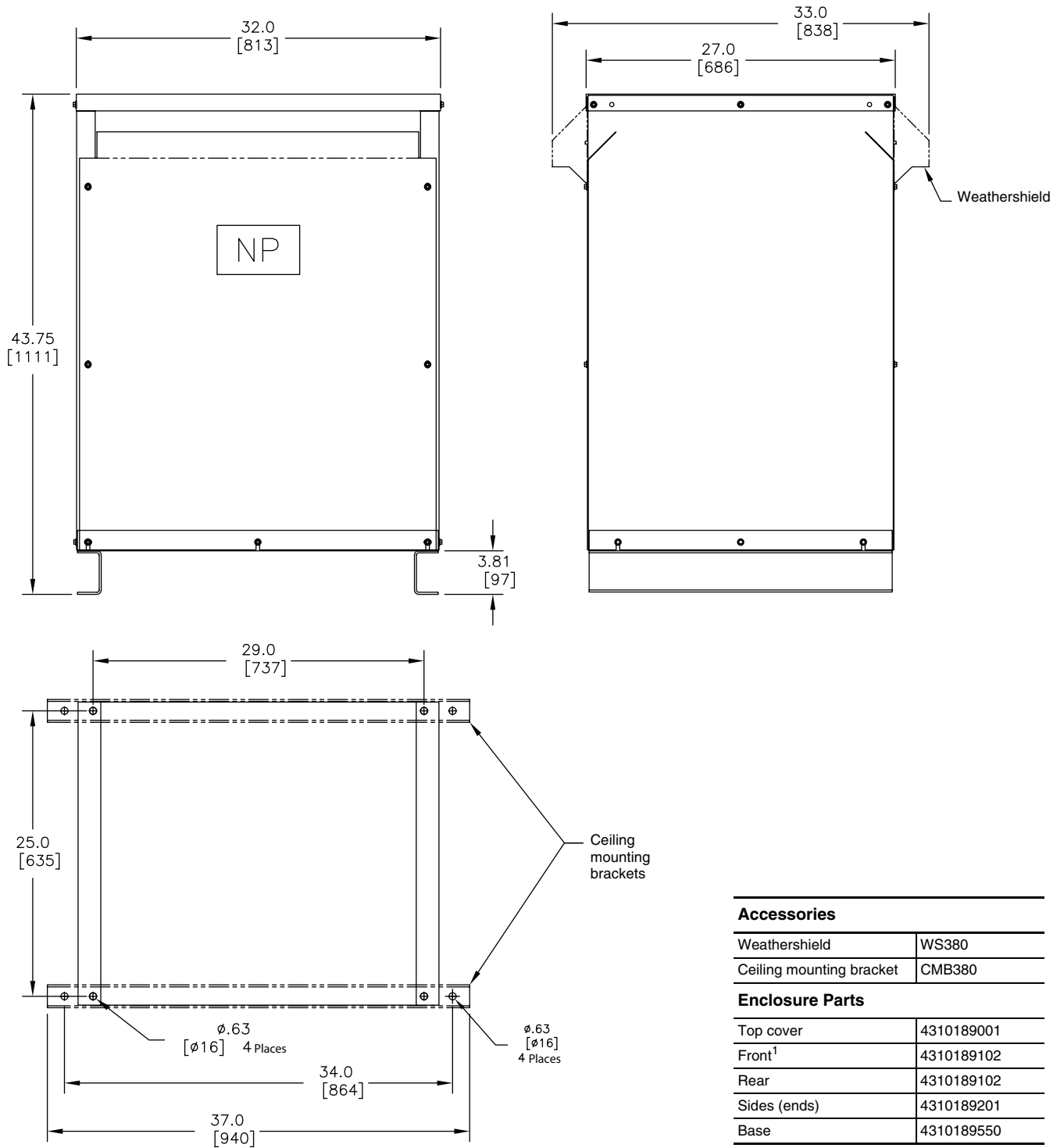

¹ When replacing a front panel, specify the transformer part number and "with nameplate and labels" on the order.

Enclosure 22D—Dry-Type Transformer

Energy Efficient Transformers

Enclosure Diagrams and Accessories

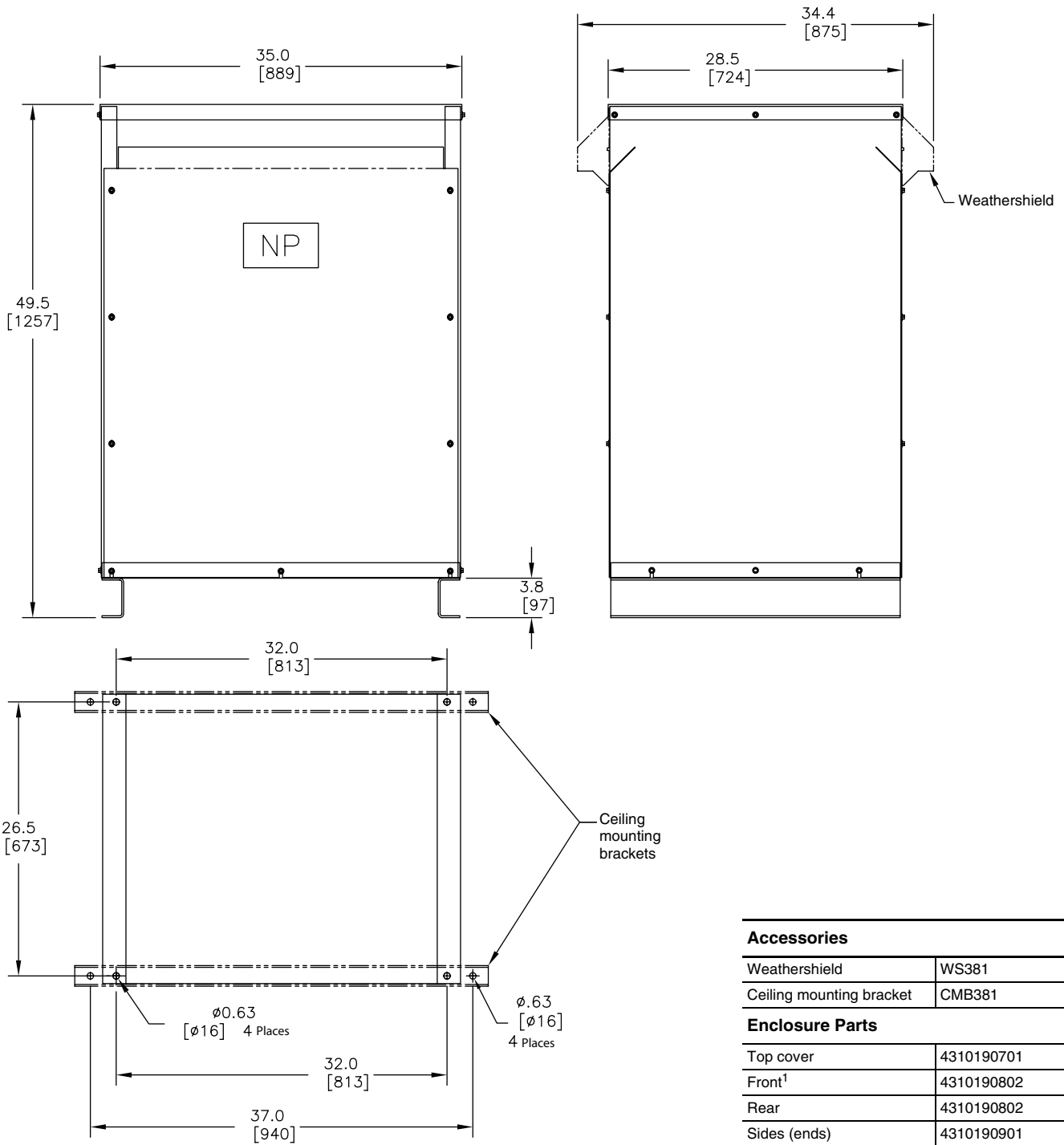

Accessories	
Weathershield	WS381
Ceiling mounting bracket	CMB381
Enclosure Parts	
Top cover	4310190701
Front ¹	4310190802
Rear	4310190802
Sides (ends)	4310190901
Base	4310191250

¹ When replacing a front panel, specify the transformer part number and "with nameplate and labels" on the order.

Enclosure 24D—Dry-Type Transformer

Energy Efficient Transformers Enclosure Diagrams and Accessories

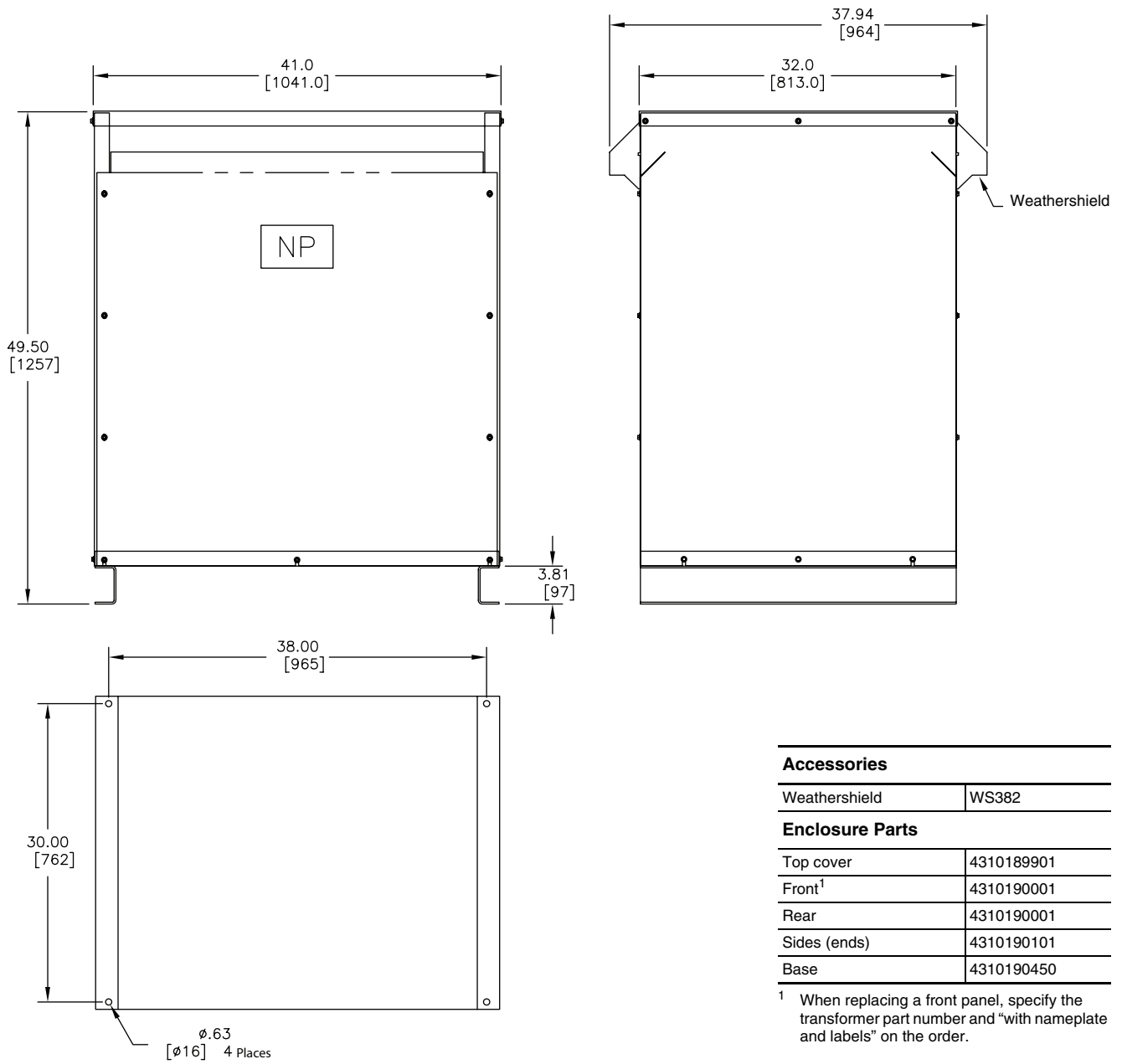

Enclosure 25D—Dry-Type Transformer

Energy Efficient Transformers

Enclosure Diagrams and Accessories

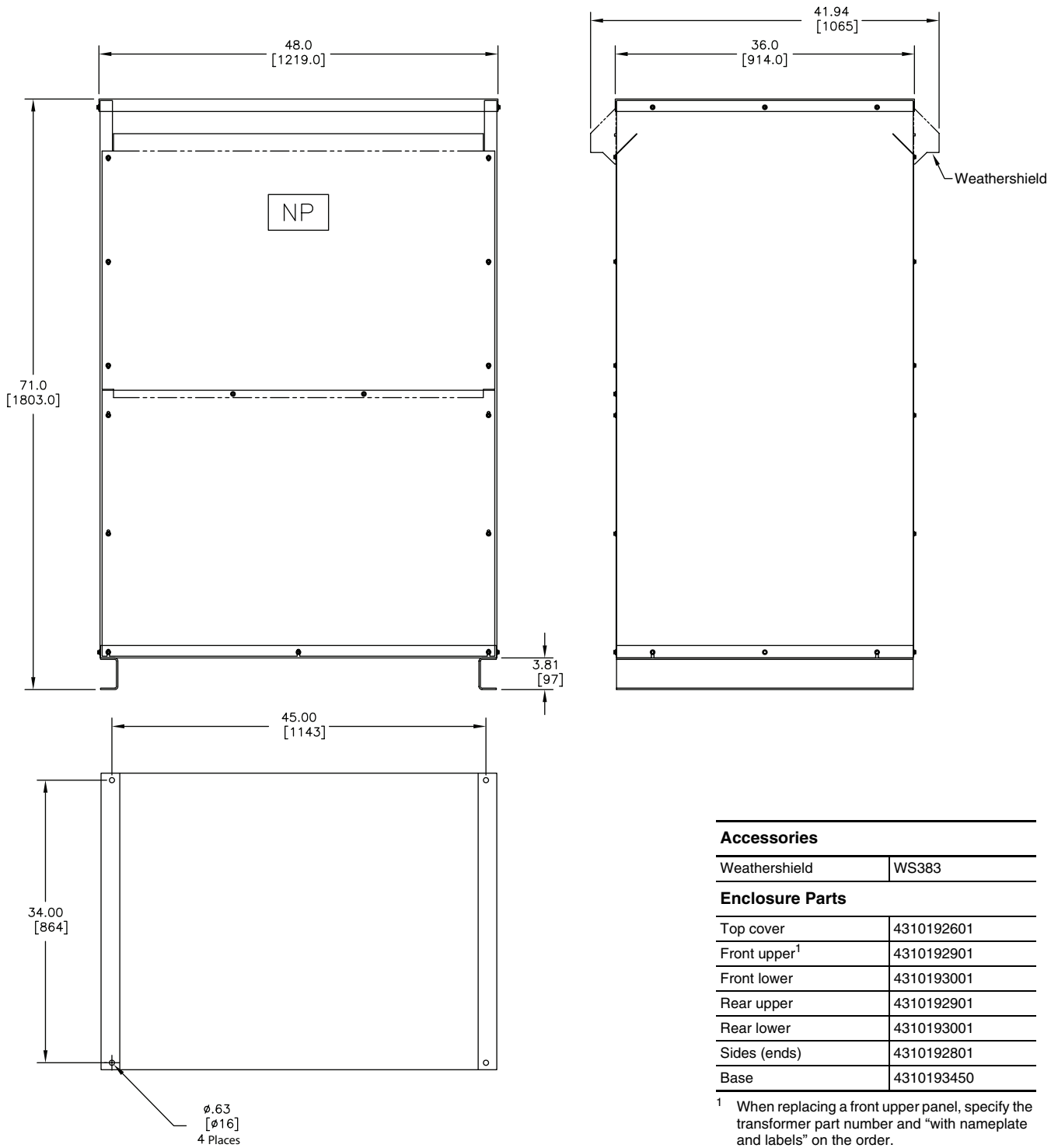

Accessories

Weathershield	WS383
---------------	-------

Enclosure Parts

Top cover	4310192601
Front upper ¹	4310192901
Front lower	4310193001
Rear upper	4310192901
Rear lower	4310193001
Sides (ends)	4310192801
Base	4310193450

¹ When replacing a front upper panel, specify the transformer part number and "with nameplate and labels" on the order.

Enclosure 30D—Dry-Type Transformer

Energy Efficient Transformers Enclosure Diagrams and Accessories

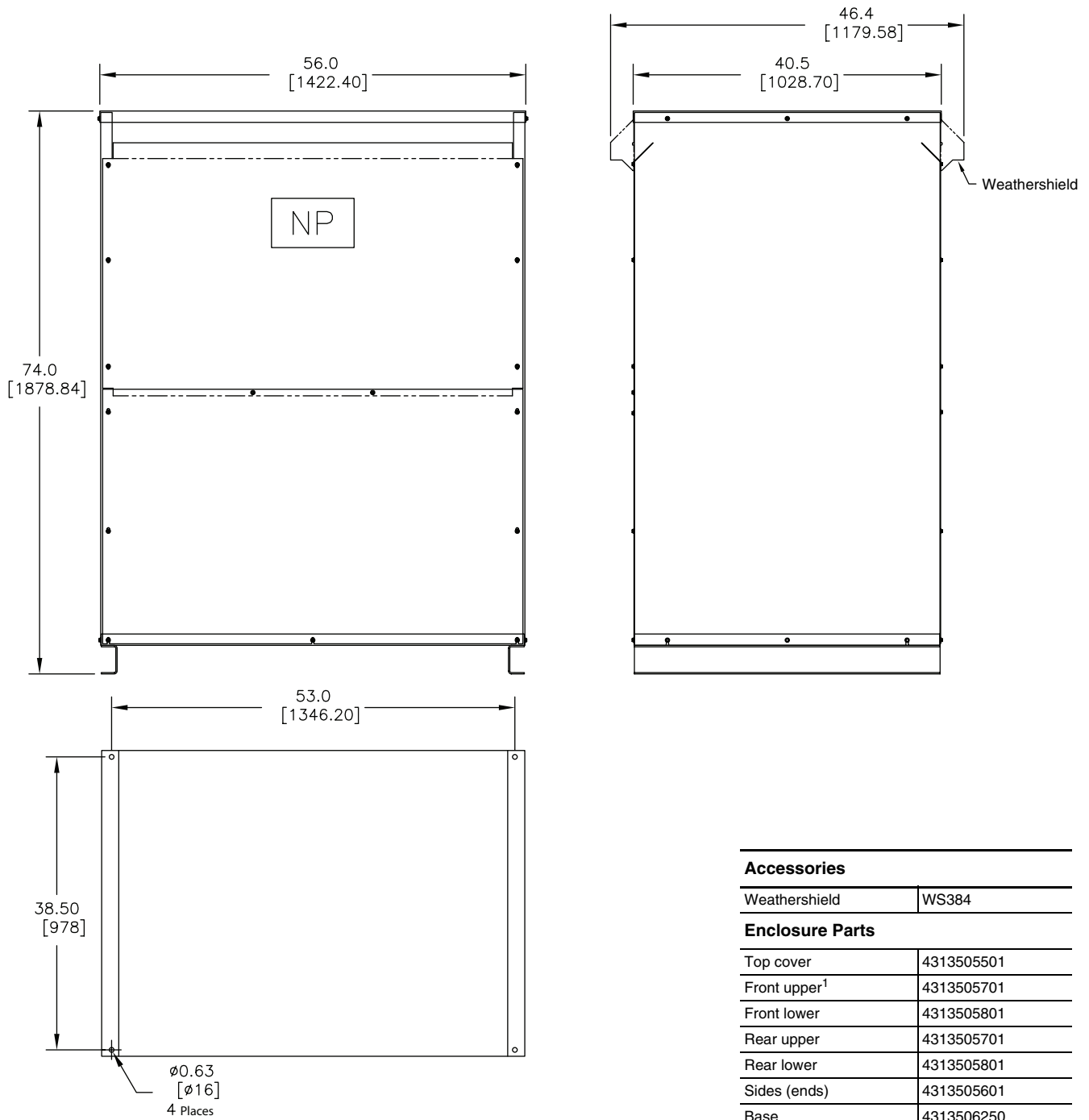

Accessories

Weathershield	WS384
---------------	-------

Enclosure Parts

Top cover	4313505501
Front upper ¹	4313505701
Front lower	4313505801
Rear upper	4313505701
Rear lower	4313505801
Sides (ends)	4313505601
Base	4313506250

¹ When replacing a front upper panel, specify the transformer part number and "with nameplate and labels" on the order.

Enclosure 31D—Dry-Type Transformer

Energy Efficient Transformers

Wiring Diagrams

Wiring Diagrams

Refer to Figures 1–9 for wiring diagram information.

Figure 1: Voltage Codes “3”, “65”, “67”, “1814”, and “1755”

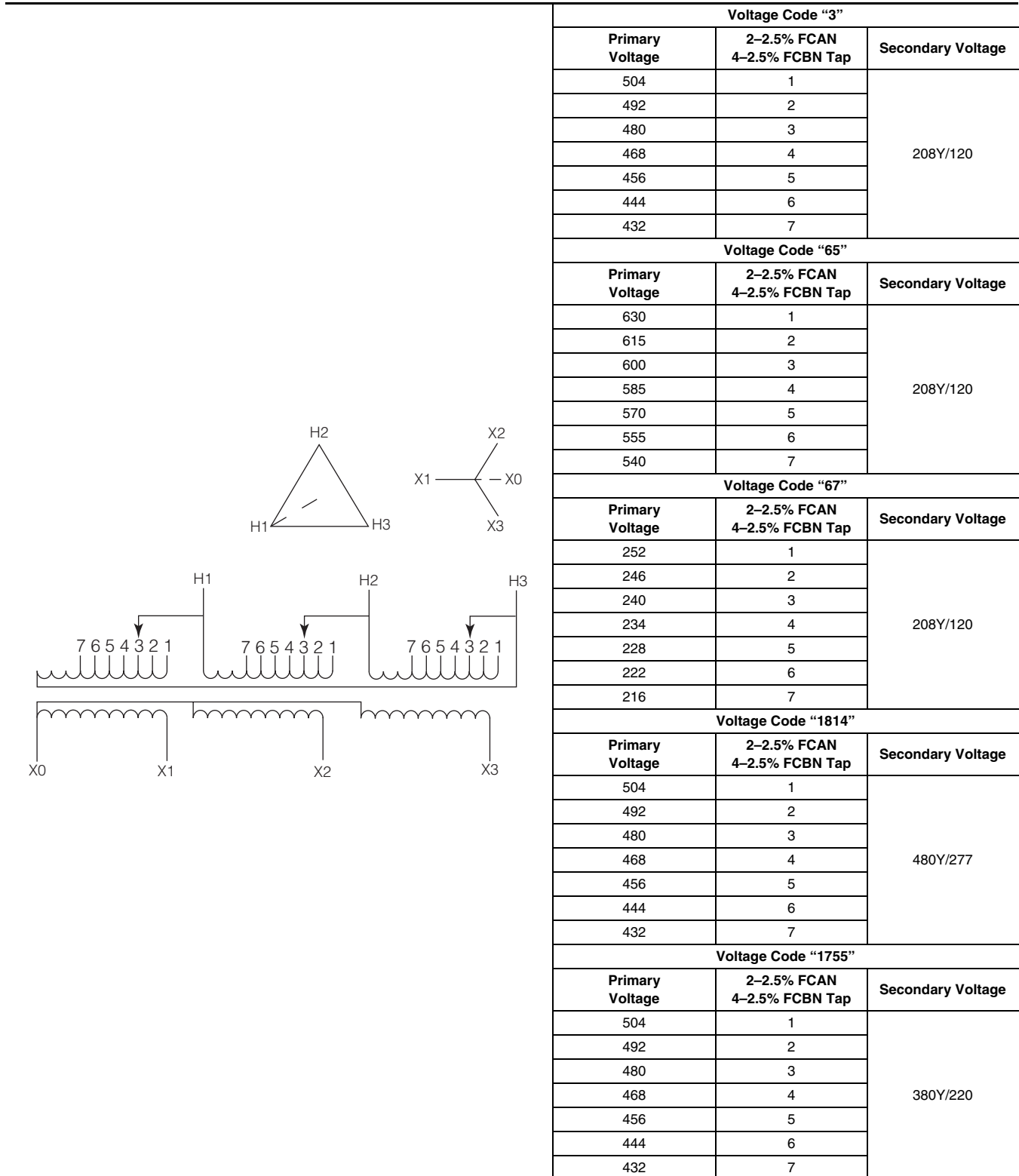
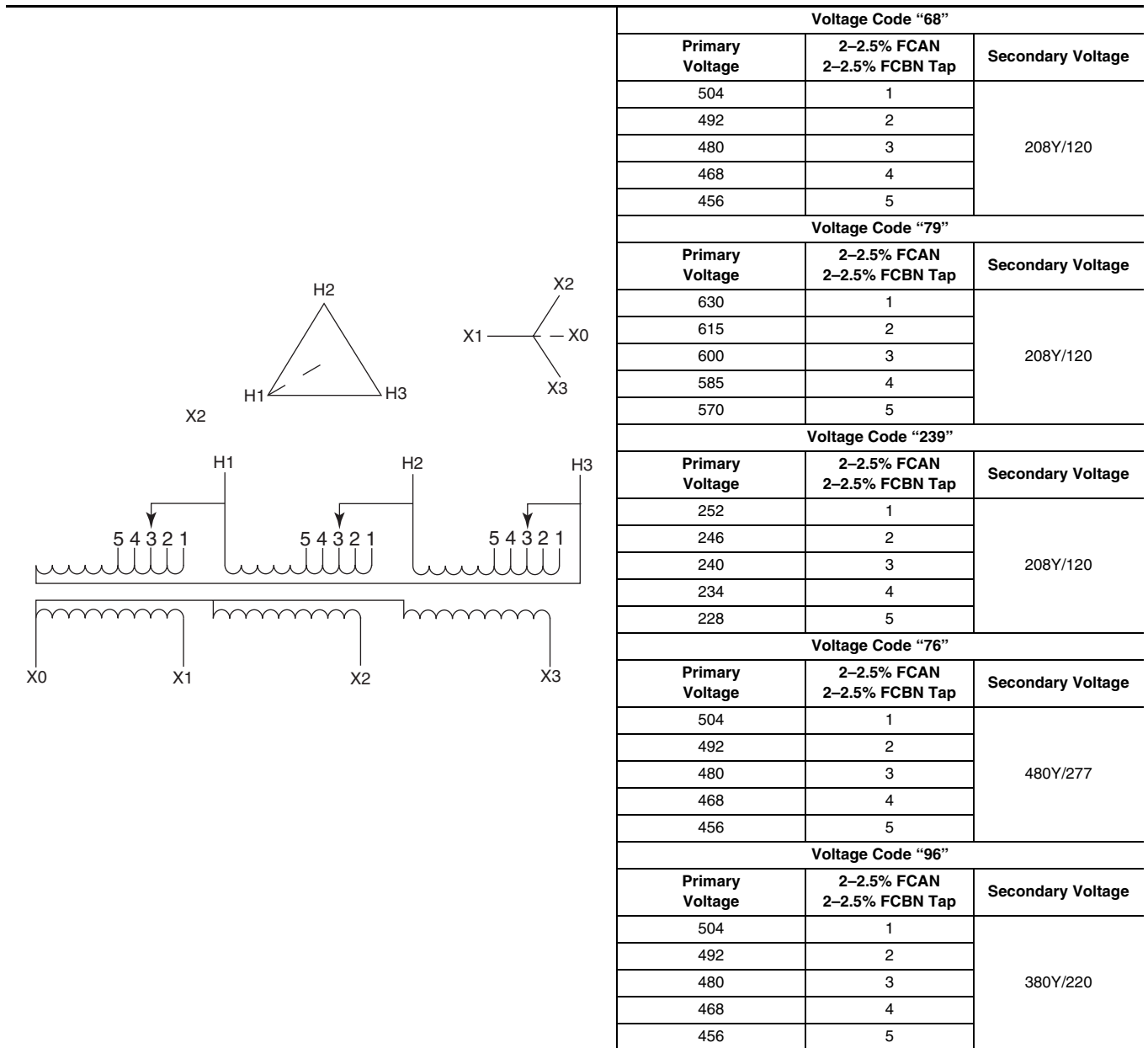

Figure 2: Voltage Codes “68”, “79”, “239”, “76”, and “96”



Energy Efficient Transformers Wiring Diagrams

Figure 3: Voltage Code “6”

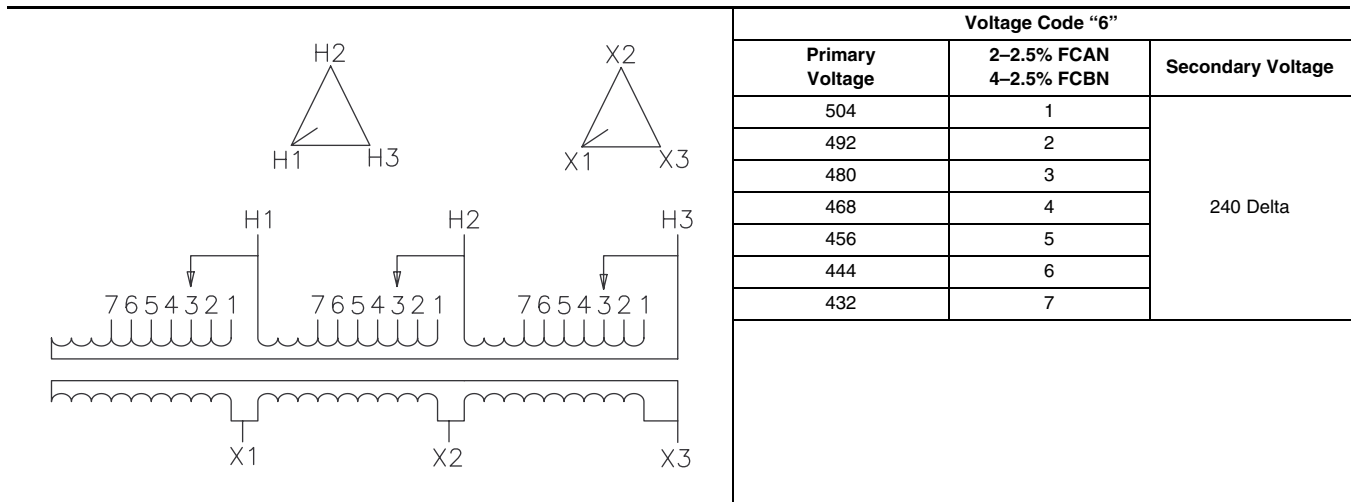

Figure 4: Voltage Code “63”

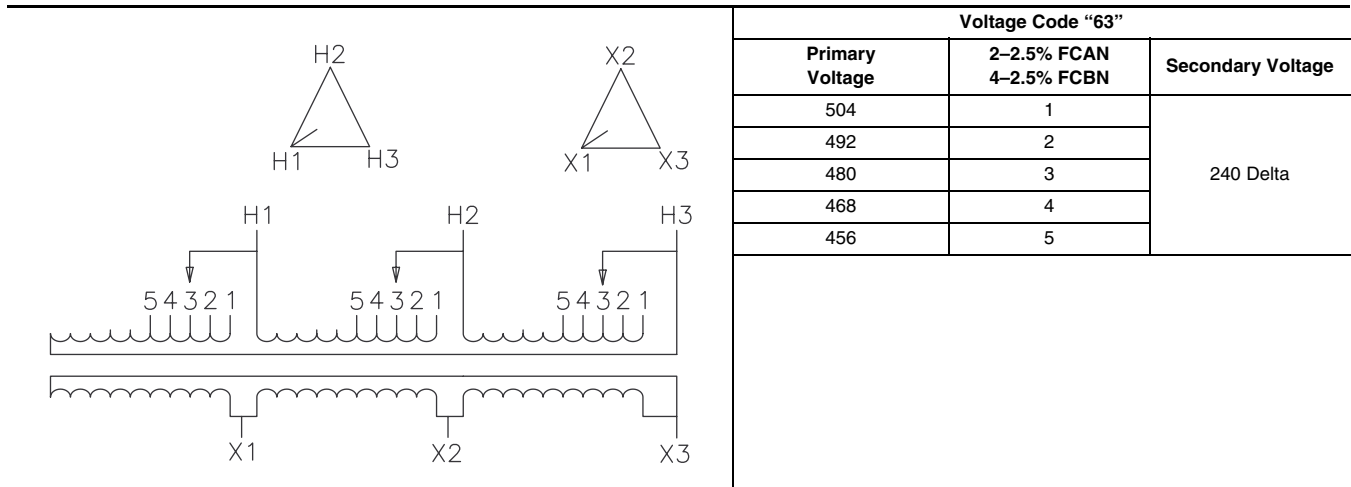

Figure 5: Voltage Code "151"

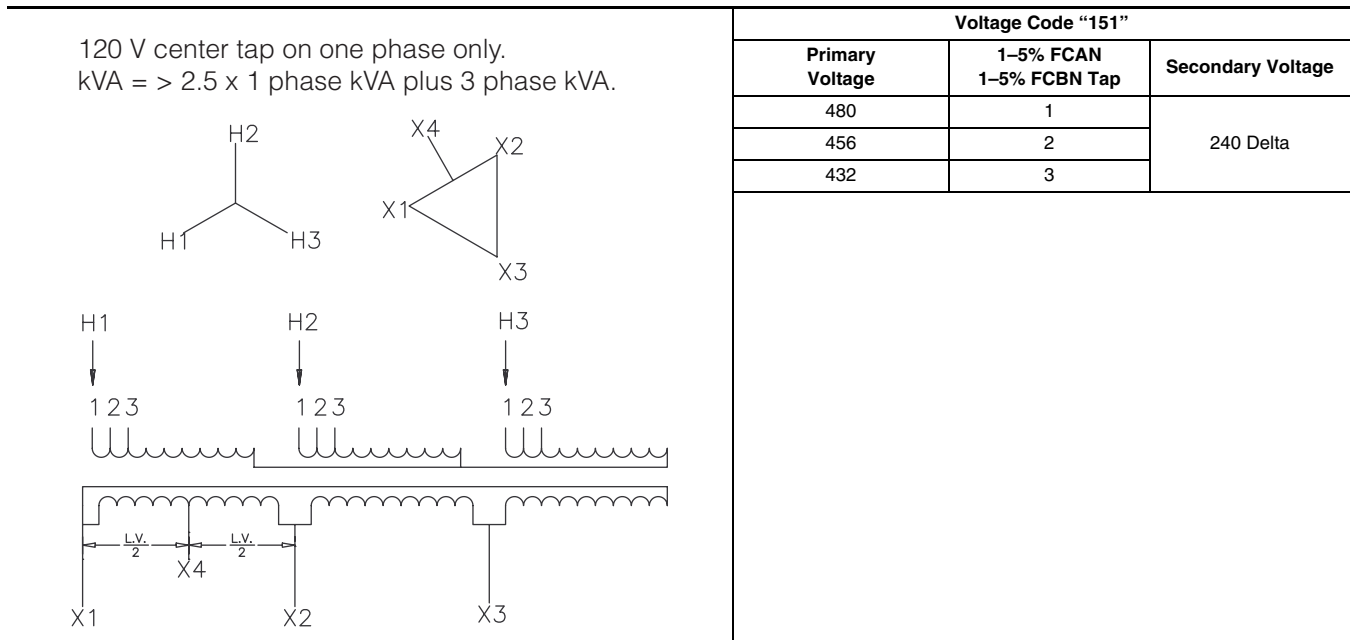

Figure 6: Voltage Code "212"

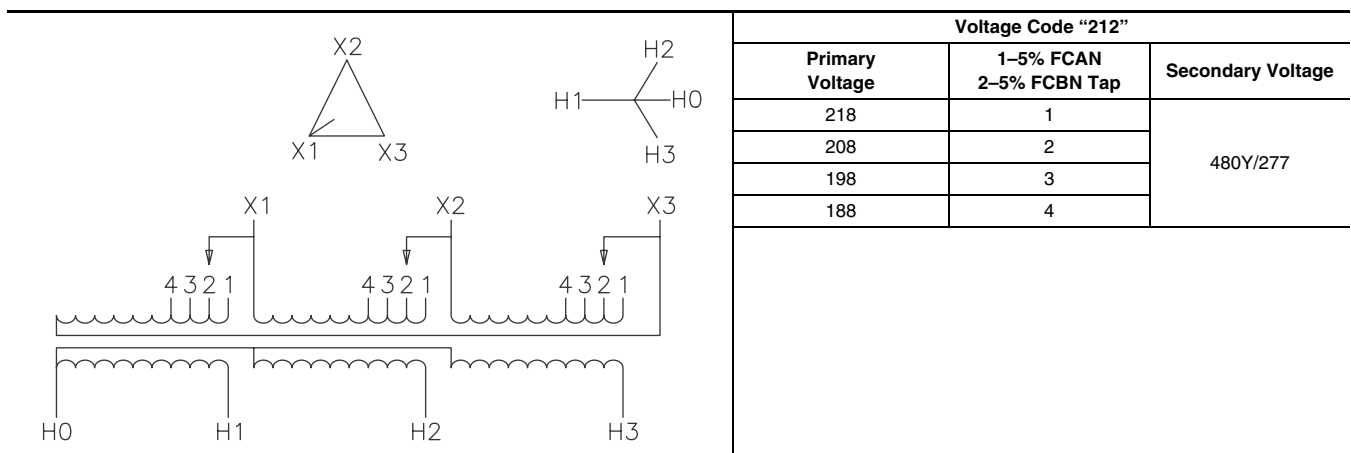
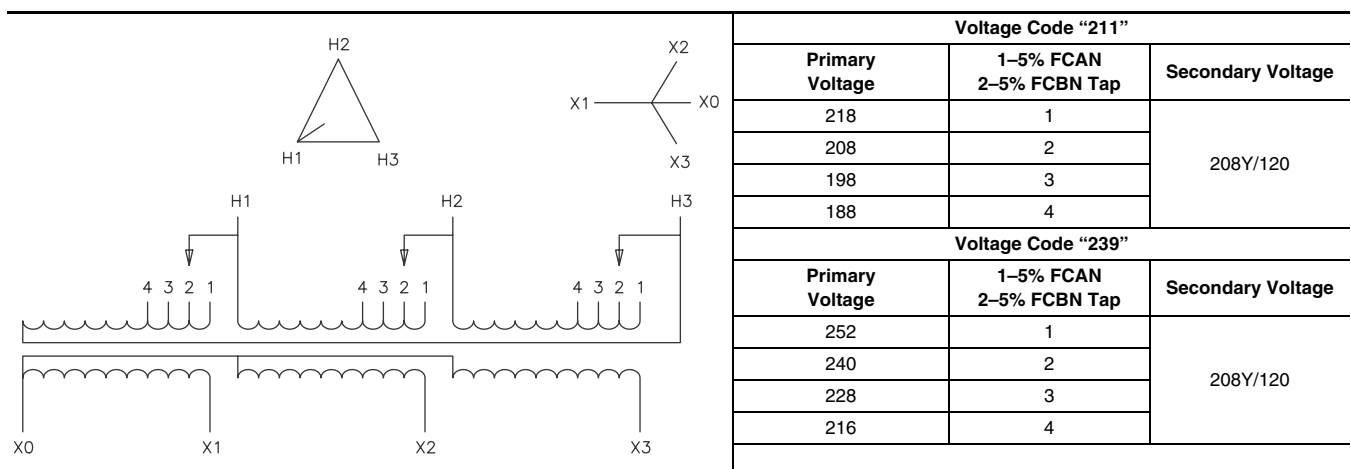

Figure 7: Voltage Codes "211" and "239"



Energy Efficient Transformers Wiring Diagrams

Figure 8: Voltage Code “3”

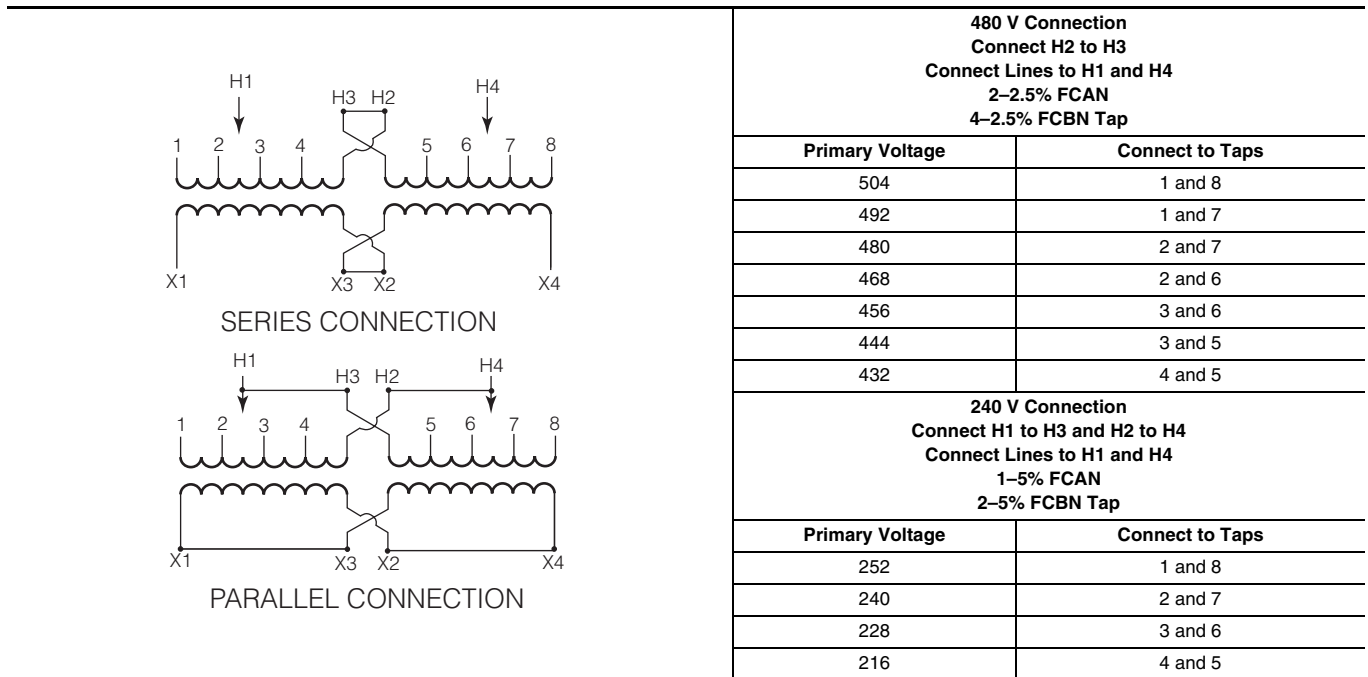
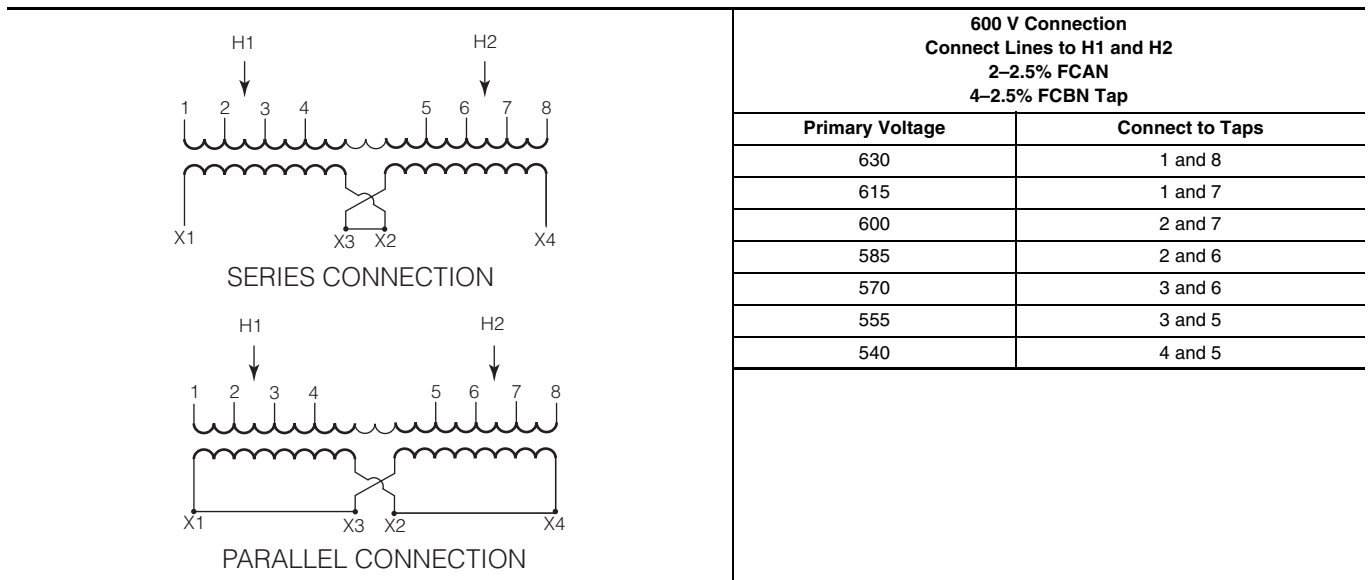

Figure 9: Voltage Code “3534”



NEC Reference: Installing and Connecting Transformers

450.9 Ventilation

Ventilation should be adequate to dispose of the transformer full load losses without creating a temperature rise that is in excess of the transformer rating.

Transformers with ventilated openings shall be installed so that the ventilated openings are not blocked by walls or other obstructions.

The required clearance shall be marked clearly on the transformer.

Square D® Energy Efficient transformers minimum clearance: three inches (76 mm).

450.13 Accessibility

All transformers and transformers vaults shall be readily accessible to qualified personnel for inspection and maintenance, or meet the requirements of (A) or (B).

(A) Open Installations

Dry-type transformers 600 volts, nominal, or less, located in the open on walls, columns, or structures, shall not be required to be readily accessible.

NEC 110.26(A)(3) other equipment that is associated with the electrical installation and is located above or below the electrical equipment shall be permitted to extend not more than 6 inches (152 mm).

NEC 110.26(E) Headroom —6.50 feet (1.8 m)

(B) Accessibility

Dry-type transformers 600 volts, nominal, or less and not exceeding 50 kVA shall be permitted in hollow spaces of buildings not permanently closed in by structure in accordance with the following:

- Meet the ventilation requirements of Section 450.9.
- Separated from combustible materials as outline in 450.21(A).

Transformers so installed shall not be required to be readily accessible

Section 300-22 Wiring in Ducts, Plenums, and Other Air-Handling Space

(C) Other Space Used for Environmental Air

(2) Electric equipment with a metal enclosure, or with a nonmetallic enclosure listed for the use and having adequate fire-resistant and low smoke-producing characteristics, and associated wiring material suitable for the ambient temperature shall be permitted to be installed in such other space unless prohibited elsewhere in this code. (450.13 above limits the kVA capacity for other space.)

FPN: The space over a hung ceiling used for environmental air-handling is an example of the type of other space to which this section applies.

450.21(B) Dry-Type Transformers Installed Indoors

Individual dry-type transformers of more than 112.5 kVA rating shall be installed in a transformer room of fire-resistant construction. Unless specified otherwise in this article, the term fire resistant means a construction having a minimum fire rating of 1 hour.

Exception 1 to this rule is relative to transformers with insulation Class 155 or higher and separations from combustible materials by space or a fire-resistant, heat-insulation barrier.

Exception 2 is relative to transformers with insulation Class 155 or higher and of the completely enclosed type, except for ventilating openings.

All Square D Energy Efficient transformers are completely enclosed (except for ventilated openings) and use Class 220 insulation.

450.12 Terminal Wiring Space

Minimum wire bending space at fixed, 600 V and below terminals of transformer line and load connections shall be as required by 312.6.

Terminal:

- A) A conducting element of an equipment or a circuit intended for connection to an external conductor
- B) A device attached to a conductor to facilitate connection with another conductor

Square D Distance from Terminals to Bottom of the Compartment (Does not Include X0)

kVA (Three-Phase: 150 °C Rise)	Inches (mm)	kVA (Single-Phase: 150 °C Rise)	Inches (mm)
15	8-3/4 (222 mm)	15	8-3/4 (222 mm)
30	8-3/4 (222 mm)	25	8-3/4 (222 mm)
45	11 (279 mm)	37.5	16-5/16 (414 mm)
75	15-1/2 (394 mm)	50	16-5/16 (414 mm)
112.5	15-11/16 (398 mm)	75	15-13/16 (402 mm)
150	18-6/16 (467 mm)	100	18-5/16 (465 mm)
225	18-1/2 (470 mm)	167	18-1/16 (459 mm)
300	18-6/16 (467 mm)		
500	19-3/16 (487 mm)		
750	19 (483 mm)		

Energy Efficient Transformers Wire Range Part Numbers and Lug Kits

Wire Range Part Numbers and Lug Kits

New primary and secondary mechanical lug kits from Schneider Electric can be coordinated with standard wire ranges for primary Square D® circuit breakers, safety switches, and panelboards. Refer to the Tables 23–27 for a listing of mechanical lug kits and wire ranges. Also, refer to catalog no. 7400CT0501 for information regarding lug kit selection and conductor and mounting hardware torque requirements.

Table 23: Primary Mechanical Lug Kits

Part Number	Lugs per Kit	Wire Range (Aluminum or Copper)	Cap Screws		Handles Same Standard Wire Range ¹	
			Quantity	Size	Square D Circuit Breaker Frame	Square D Safety Switch Amperage Rating
DASKP100	3	1/0–14 STR. ²	3	1/4 x 1 in	F-Frame, G-Frame Powerpact® Q ³ , Powerpact H	100 A
DASKP250	3	350 kcmil–6 STR.	3	1/4 x 1 in	Powerpact Q ⁴ , Powerpact J	200 A
DASKP400	3	600 kcmil–4 STR. (2) 250 kcmil–1/0 STR. ⁵	3	1/4 x 1 3/4 in	Q4-Frame, L-Frame (400 A)	400 A
DASKP600	6	600 kcmil–4 STR. (2) 250 kcmil–1/0 STR. ⁵	6	1/4 x 1 3/4 in	L-Frame (600 A)	600 A
DASKP1000	9	600 kcmil–2 STR.	9	3/8 x 2 in	Powerpact M	800 A
DASKP1200	12	600 kcmil–2 STR.	12	3/8 x 2 in	Powerpact P	1200 A

¹ Does not handle the full range of safety switches, but is acceptable since extra capacity is for voltage drop. Normally, this is not an issue because of the National Electrical Code (NEC) for primary protection distance on transformers.

² STR. = Strand

³ Handles through 1/0, not 300 kcmil

⁴ Does not handle 8–14 STR

⁵ 7400DASKP400 and 7400DASKP600 require two (2) wires per lug

Table 24: Secondary Mechanical Lug Kits

Part Number	Lugs per Kit	Wire Range (Aluminum or Copper)	Cap Screws		Handles Same Standard Wire Range ¹			Bonding Lugs	
			Qty.	Size	Square D Circuit Breaker Frame (Molded Case Switches)	Panelboards: -Main Lugs Main - Circuit Breaker	Safety Switch Amp. Rating	Lugs per Kit	Wire Range (Aluminum or Copper)
DASKS100	5	1/0–14 STR. ²	6	1/4 x 1 in	F-Frame G-Frame Powerpact Q ³	100 A NQOD 100 A I-Line®	100 A	1	2–14 STR.
DASKS250	5	350 kcmil–6 STR.	6	1/4 x 1 in	Q-Frame ⁴ Powerpact J	225 A NQOD 250 A NF 225 A I-Line	200 A	1	2–14 STR.
DASKS400	5	600 kcmil–4 STR. (2) 250 kcmil–1/0 STR. ⁵	6	1/4 x 1 3/4 in	Q4-Frame L-Frame (400 A)	400 A NQOD ⁶ 400 A NF ⁶ 400 A I-Line	400 A	1	1/0–14 STR.
DASKS600	10	600 kcmil–2 STR.	11	1/4 x 1 3/4 in	L-Frame (600 A)	600 A NQOD (Main Lug Only) 600 A NF ⁶ 600 A I-Line	600 A	1	250 kcmil–6 STR.
DASKS1000	15	600 kcmil–2 STR.	16	3/8 x 2 in	Powerpact M	600 A NQOD (Main Breaker Only) 800 A NF 800 A I-Line	800 A	1	250 kcmil–6 STR.
DASKS1200	20	600 kcmil–2 STR.	21	3/8 x 2 in	Powerpact P	1200 A I-Line	1200 A	1	250 kcmil–6 STR.
DASKS2000	25	600 kcmil–2 STR.	26	3/8 x 2 in	—	—	—	1	350 kcmil–6 STR.

¹ Does not handle the full range of safety switches, but is acceptable since extra capacity is for voltage drop. Normally, this is not an issue because of the NEC for primary protection distance on transformers.

² STR. = Strand

³ Handles through 1/0 not 300 kcmil

⁴ Does not handle 8–14 STR

⁵ 7400DASKS400 allows for two conductors (2) wire range supplied

Energy Efficient Transformers Wire Range Part Numbers and Lug Kits

⁶ (2) 250 kcmil not 300 kcmil (Main Lug) - (1) 600 kcmil not 750 kcmil (Main Lug)

Table 25: Three-Phase, 480 V Primary

kVA	Primary Voltage	Primary Current	NEC 450-3 (125%) Max. Amp. Ratings per NEC 240.6	Primary Lug Kit	NEC 450-3 (250%) Max. Amp. Ratings per NEC 240.6	Primary Lug Kit
15	480	18.06	25	DASKP100	45	DASKP100
30		36.13	50	DASKP100	90	DASKP100
45		54.19	70	DASKP100 DASKP250	125	DASKP250
75		90.32	125	DASKP250 DASKP400	225	DASKP250 DASKP400
112.5		135.48	175	DASKP250 DASKP400	300	DASKP250 DASKP400
150		180.64	225	DASKP250 DASKP400	450	DASKP600 ¹
225		270.95	350	DASKP400 DASKP600	600	DASKP600 DASKP1000 ¹
300		361.27	450	DASKP600	800	DASKP1000 ¹
500		602.12	800	DASKP1000	1200	DASKP1200 ¹

¹ Terminals are designed for back to back mounting.

Table 26: Three-Phase, 600 V Primary

kVA	Primary Voltage	Primary Current	NEC 450-3 (125%) Max. Amp. Ratings per NEC 240.6	Primary Lug Kit	NEC 450-3 (250%) Max. Amp. Ratings per NEC 240.6	Primary Lug Kit
15	600	14.45	20	DASKP100	45	DASKP100
30		28.90	40	DASKP100	90	DASKP100 DASKP250
45		43.35	60	DASKP100	125	DASKP250
75		72.25	100	DASKP100 DASKP250	225	DASKP250 DASKP400
112.5		108.38	150	DASKP250 DASKP400	300	DASKP250 DASKP400
150		144.51	200	DASKP250 DASKP400	450	DASKP400 DASKP600 ¹
225		216.76	300	DASKP400 DASKP600	600	DASKP600 DASKP1000 ¹
300		289.02	400	DASKP600	800	DASKP1000 ¹
500		481.70	700	DASKP1000	1200	DASKP1200 ¹

¹ Terminals are designed for back to back mounting.

Table 27: Three-Phase, 208Y/120 V Secondary

kVA	Secondary Voltage	Secondary Current	NEC 450-3 (125%) Max. Amp. Ratings per NEC 240.6	Secondary Lug Kit
15	208Y/120	41.69	60	DASKS100
30		83.37	110	DASKS250
45		125.06	175	DASKS250
75		208.43	300	DASKS250 DASKS400
112.5		312.64	400	DASKS400
150		416.85	600	DASKS600
225		625.28	800	DASKS1000 ¹
300		833.70	1200	DASKS1200
500		1389.51	2000	DASKS2000

¹ Terminals are designed for back to back mounting.



Lug from DASKS400 kit mounted on a EE75T3H X terminal

Energy Efficient Transformers Specifications

Specifications

Part 1 General

1.01 Section Includes

Dry-type energy efficient transformers per NEMA TP-1 and CSA 802.2-00, with primary and secondary voltages of 600 V and less and capacity ratings 15 kVA through 750 kVA.

NOTE: Paragraphs and words marked in brackets [] are alternates. Select only one.

1.02 References

- A. NFPA 70—National Electrical Code
- B. NEMA ST20
- C. UL 1561
- D. CSA C22.2
- E. NEMA TP-2
- F. NEMA TP-1
- G. CSA 802.2-00

1.03 Submittals

Suppliers asking considerations as an approved equal shall submit complete, warranted performance data and physical dimensions for similar transformers. Data shall be submitted for each size specified, and shall be received by the consultant engineer no less that 10 days prior to the bid due date for consideration.

1.04 Standards

- A. Transformers 750 kVA and smaller shall be listed by third party testing agency.
- B. Transformers conform to the requirements of ANSI/NFPA 70.
- C. Transformers are to be manufactured and tested in accordance with NEMA ST20 and CSA22.2 No. 47.

Part 2 Products

2.01 Manufacturers

- A. Transformers shall be as manufactured by Schneider Electric or approved equal.
- B. Approved manufacturers shall be registered firms in accordance with ISO 9001: 1994 SIC 3612 (US), which is the design and manufacture of low voltage dry-type power, distribution, and specialty transformers.

2.02 Ratings information

- A. All insulating materials are to exceed NEMA ST20 standards and be rated for 220 °C UL component recognized insulation system.
- B. Transformers 15 kVA and larger shall be 150 °C temperature rise above 40 °C ambient. Transformers 25 kVA and larger shall have a minimum of 4–2.5% full capacity primary taps. Exact voltages and taps to be as designated on the plans or the transformer schedule.
- C. The maximum temperature of the top of the enclosure shall not exceed 50 °C rise above a 40 °C ambient.
- D. Transformers shall be low loss type with minimum efficiencies per the table below when operated at 35% of full load capacity. Efficiency shall be tested in accordance with NEMA TP-2 and CSA 802.2-00.

Single-Phase		Three-Phase	
kVA	% Efficiency	kVA	% Efficiency
15.0	97.7	15.0	97.0
25.0	98.0	30.0	97.5
37.5	98.2	45.0	97.7
50.0	98.3	75.0	98.0
75.0	98.5	112.5	98.2
100.0	98.6	150.0	98.3
167.0	98.7	225.0	98.5
250.0	98.8	300.0	98.6
333.0	98.9	500.0	98.7
—	—	750.0	98.8

Table per NEMA TP-1 CSA 802.2-00 and Energy Act of 2005 (US Public Law 109-58)

- E. The transformer(s) shall be rated as indicated in the following schedule:
 - Identification number(s)
 - kVA rating
 - Voltages
 - Phase
 - Frequency

2.03 Construction

- A. Transformer coils shall be of the continuous wound construction and shall be impregnated with non hygroscopic, thermosetting varnish.
- B. All cores to be constructed with low hysteresis and eddy current losses. Magnetic flux densities are to be kept well below the saturation point to prevent core overheating. Cores for transformers greater than 500 kVA shall be clamped utilizing insulated bolts through the core laminations to ensure proper pressure throughout the length of the core. The completed core and coil shall be bolted to the base of the enclosure, but isolated by means of rubber vibration-absorbing mounts. There shall be no metal-to-metal contact between the core and coil and the enclosure except for a flexible safety ground strap. Sound isolation systems requiring the complete removal of all fastening devices will not be acceptable.

Energy Efficient Transformers Specifications

- C. The core of the transformer shall be visibly grounded to the enclosure by means of a flexible grounding conductor sized in accordance with applicable [UL and NEC] [CSA and CEC] standards.
- D. The transformer enclosures shall be ventilated and be fabricated of heavy gauge, sheet steel construction. The entire enclosure shall be finished utilizing a continuous process consisting of degreasing, cleaning, and phosphatizing, followed by electrostatic deposition of polymer polyester powder coating and baking cycle to provided uniform coating of all edges and surfaces. The coating shall be UL recognized for outdoor use. The coating color shall be ANSI 49.

2.04 Sound Levels

Sound levels shall be warranted by the manufacturer not to exceed the following:

kVA Rating	Sound Level
15 to 50 kVA	45 dB
51 to 150 kVA	50 dB
151 to 300 kVA	55 dB
301 to 500 kVA	60 dB
501 to 700 kVA	62 dB
701 to 1000 kVA	64 dB
1001 to 1500 kVA	65 dB
1501 to 2000 kVA	66 dB

NOTE: Lower sound levels may be desirable for critical areas such as hospitals, schools, or office areas. Contact your local Schneider Electric representative for specific recommendations.

2.05 Optional Accessories

- A. [Provide weathershields for units ID#_____ 750 kVA max.]
- B. [Provide wall mounted brackets for units ID#_____ 75 kVA max. for three-phase, 50 kVA max. for single-phase]
- C. [Provide ceiling mounting brackets for units ID#_____ 150 kVA max.]

Part 3 Execution

3.01 Installation

Not used.

Frequently Asked Questions and Answers

What is an Energy Efficient Transformer?

Square D® Type EE Energy Efficient Transformers are designed to meet NEMA Standard TP-1 efficiency standards. Lower core loss and emphasis on maximizing efficiency at typical average loading levels of 35 percent are keys to reduced energy costs in low voltage dry-type Energy Efficient Transformers.

How do the dimensions of Energy Efficient Transformers compare with standard General Purpose Transformers?

Type EE transformers have the same dimensions as standard, 150 °C rise General Purpose Transformers.

What is the typical difference in price between Type EE Transformers and standard 150 °C rise General Purpose Transformers?

The price of Type EE Transformers can be as high as 35 percent more than standard transformers. However, that increased initial cost can typically be paid back in energy cost savings in five to six years based on \$.075 per kWh utility rate. Therefore, the long-term cost of ownership for Type EE Transformers is actually less than General Purpose Transformers.

Approximately how many watts can these transformers save?

At typical average load of 35 percent, the average loss in watts for Type EE Transformers is 30 percent lower than standard, 150 °C rise General Purpose Transformers. The improvement in efficiency at that loading level is primarily a result of significantly reduced core loss. However, even at full load, the savings in watts is typically 15 percent.

When should I specify a Type EE transformer over a standard one?

A Type EE transformer can be beneficial in any situation where energy savings is a concern. We all have a stake in preserving world energy reserves. The opportunity to contribute towards reduced energy consumption and to provide pay back in the long run for your customers are compelling reasons to specify an Energy Efficient transformer.

What is the difference between Square D Energy Savings Watchdog® Transformers and Energy Efficiency Transformers.

Watchdog transformers have far lower full-load losses than either Type EE or General Purpose Transformers. That advantage rapidly disappears as loading is reduced, typically reaching a trade off at 50 –75 percent load. Surveys show that average loading is 35 percent for low voltage transformers over a typical 24-hour period. Use of Watchdog transformers at that loading level would actually represent a loss penalty over standard transformers because of the inherently greater core loss. Type EE transformers are designed to replace Watchdog transformers in the role of energy savings at more typical levels of loading.

How does the presence of harmonics, such as in high-density office computer and network load currents, affect energy efficiency?

Harmonics do lessen the efficiency of all transformers. Harmonics cause somewhat higher losses in transformer windings (as much as 30 percent for most Square D Transformers). Type EE transformers are no more susceptible than any other transformer to the effect of harmonics. Type EE transformers provide the same percentage of loss reduction compared with General Purpose Transformers, or even K-Factor rated transformers under the same load conditions. Because the average loading of low voltage transformers is normally only 35 percent, a K-factor rating is not necessary for Type EE transformers.

Schneider Electric USA

1010 Airpark Center Drive
Nashville, TN 37217 USA
1-888-Square D
1-888-778-2733
www.us.SquareD.com

7400CT0601R03/07 © 1999–2007 Schneider Electric All Rights Reserved
Replaces 7400CT0601, 07/2006; 7435CT9901, 11/1999; 7400PD9802, 09/1998