



TAC
1354 Clifford Avenue
P. O. Box 2940
Loves Park, IL 61132-2940
www.tac.com

MS40-717X Series

TAC DuraDrive™ Series Spring Return Proportional Actuators General Instructions

Application

TAC DuraDrive Direct Coupled Actuators are designed to be used in both damper and valve control applications. The following general instructions are for damper applications, refer to the Applicable Literature table for valve literature.

The MS40-717X series actuators are over the shaft spring return actuators compatible with 2 to 10 Vdc or 4 to 20 mA¹ control signals.

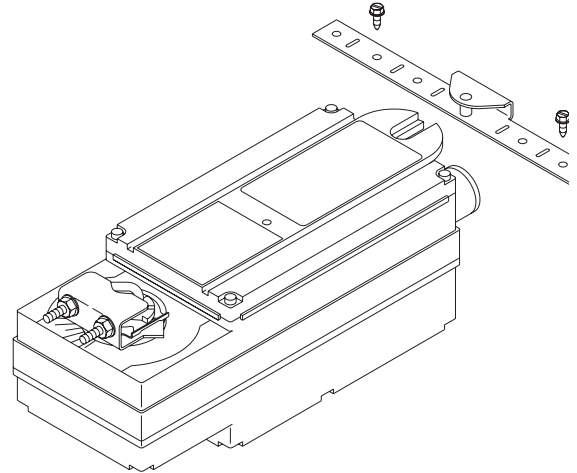

Features

- 150 lb-in (17 N-m) rated torque
- NEMA Type 4 housing (IEC IP56)
- Custom automatic current sensing motor control provides extended reliability and repeatable timing
- Direct coupled to the damper shaft with dual industrial hardened universal mounting clamps
- Integral wiring for proportional control by 2 to 10 Vdc or 4 to 20 mA¹
- Clockwise or counterclockwise spring return is determined by actuator mounting position
- Accurate 92° travel digitally controlled
- Integral position indication scale
- Rugged die-cast housing
- Oil immersed gear train provides continuous lubrication
- Integral transformer for high voltage systems
- Rated for operating temperature up to 140 °F
- Five year warranty
- MS40-717x series actuators can be double-mounted (gang mounting) to accommodate high torque application requirements (2 to 4 actuators).
- Position feedback signal

¹. With the addition of a 500 Ohm resistor - not included

Applicable Literature

F-Number	Description	Audience	Purpose
F-26750	MX40-6XXX-2XX, MX40-7XXX-2XX Series Actuator/Linkage Assemblies General Instructions	<ul style="list-style-type: none"> - Sales Personnel - Application Engineers - Installers - Service Personnel - Start-up Technicians 	Describes the globe valve actuator/linkage assembly's features, specifications, and possible applications. Provides step-by-step mounting instructions.
F-26646	MX40-7XXX, MX40-6XXX Series TAC DuraDrive Actuator Selection Guide	<ul style="list-style-type: none"> - Sales Personnel - Application Engineers - Installers - Service Personnel - Start-up Technicians 	Provides actuator specifications and part number cross referencing of phased out actuators with the new TAC direct-coupled actuators.
F-26752	VX-2000, VX-7000 Series MX40-7XXX, MX40-6XXX Series Ball/Linked Globe Valve Assemblies Actuator/Linkage Assemblies Selection Guide	<ul style="list-style-type: none"> - Sales Personnel - Application Engineers - Installers - Service Personnel - Start-up Technicians 	Provides part number cross referencing of phased out actuators with the new TAC direct-coupled actuators.
F-26080	EN-205 Water System Guidelines	<ul style="list-style-type: none"> - Application Engineers - Installers - Service Personnel - Start-up Technicians 	Describes TAC approved water treatment practices.
F-13755	CA-28 Control Valve Sizing	<ul style="list-style-type: none"> - Application Engineers - Installers - Service Personnel - Start-up Technicians 	Provides charts, equations, and diagrams to assist in the configuration of valve system applications. TOOL-150, valve sizing slide rule may be purchased separately.
F-11080	Valve Selection Chart Water		
F-11366	Valve Selection Chart Steam (two-way valves only)		

SPECIFICATIONS

Inputs

Control Signal: 4 to 20 mA_{dc} (with the addition of a 500 Ohm resistor - not included) or 2 to 10 V_{dc}. See Figure-1 through Figure-8.

Power Input: See Table-1. All 24 Vac and 22-30 V_{dc} circuits are Class 2. All circuits 30 Vac and above are Class 1.

Impedance: 2 to 10 V_{dc}, 121k Ω . 4 to 20 mA_{dc}, 500 Ω . (user supplied).

Connections:

Class 1 Power, 24 inch (61 cm) long, 18 AWG color coded pigtail leads.

Class 2 Power & Control, 36 inch (91 cm) long, 22 AWG color coded appliance cable leads.

Ground, 36 inch (91 cm) long, 18 AWG green/yellow pigtail lead.

Outputs

Electrical:

Position Feedback Voltage, "AO" 2 to 10 V_{dc} (max. 0.5 ma) output signal for position feedback or to operate up to four additional slave actuators.

Stroke, Electronically limited to 92° \pm 1°.

Action, Direct acting, 0° position with 4 mA_{dc} or 2 V_{dc} input.

Torque See Table-1.

Duty Cycle 100%.

Timing See Table-1.

Mechanical:

Anti-Rotation Bracket,

Standard 9" long x 13/16" wide (229 x 21 mm), included with the actuator.

Optional Order AM-752 (4" long x 1-11/16" wide) for mounting the actuator in narrow spaces.

Universal Mounting Clamps, Two clamps are required for all mounting configurations.

Standard 3/8" to 1/2" (10 to 13 mm) round and square shaft mounting clamps are included with the actuator.

Optional Order AM-753 for 5/8" (16 mm) square and 3/4" to 1" (19 to 25 mm) round damper shafts, two per package.

Minimum Damper Shaft Length,

Standard Damper shaft must be at least 4-5/8" (117 mm) long for standard mounting.

Optional Shorter than standard length shafts require the AM-676 shaft extension (order separately).

Position Indicator, Scale numbered from 0 to 95°, provided for position indication.

Nominal Damper Area, Actuator sizing should be done in accordance with damper manufacturer's specifications.

Direction of Rotation, Clockwise or counterclockwise rotation is determined by actuator mounting. The zero (0) position on the position indicator is the normal or spring return position.

Environment

Ambient Temperature Limits:

Shipping & Storage, -40 to 160°F (-40 to 71°C).

Operating, -25 to 140°F (-32 to 60°C).

Humidity: 5 to 95% RH, non-condensing.

Location: NEMA 1. NEMA Type 4 (IEC IP56) with customer supplied water tight conduit connectors.

Agency Listings

UL 873: Underwriters Laboratories Inc. listed (File # E9429 Category Temperature-Indicating and Regulating Equipment).

CUL: UL Listed for use in Canada by Underwriters Laboratories. Canadian Standards C22.2 No. 24-93.

European Community: EMC Directive (2004/188/EC). Low Voltage Directive (72/23/EEC). See Table-1 for specific models.

Australia: This product meets requirements to bear the C-Tick Mark according to the terms specified by the Communications Authority under the Radiocommunications Act 1992.

Table-1 Model Chart.

Part Number	Actuator Power Input					Approximate 93° Rotation Timing in Seconds @ 70° F (21°C) for Rated Torque		Output Torque Rating lb.-in. (N-m)		
	Voltage	Hz		Running Watts	VA		Powered	Spring Return	Minimum	Maximum Stall
					Running	Holding				
MS40-7173	24 Vac ±20%	50	60	5.5	7.8	4.7	147	65	150 (17) ^a	545 (61.8)
	22-30 Vdc			5.0	5.6	2.5				
MS40-7170	120 Vac ±10%	50	60	6.4	8.5	5.2				
MS40-7171	240 Vac ±10%			7.2	10.8	9.0				

^a Approximate 2% torque derating per 1°F above 122°F in the drive direction.

ACCESSORIES

- AM-620 Remote mount single/dual damper actuator kit
- AM-621 Round damper shaft extension kit (1/2" ID x 1" OD) for dual actuator mounting
- AM-703 Span adjustment
- AM-704 Modulation Interface, converts a PWM to 2 to 10 Vdc
- AM-705 Positioner, remote/minimum positioning
- AM-706 Positioner, flush mount digital position indicator
- AM-707 Digital Indication
- AM-708 Resistor for 500Ω modulating signal conversion
- AM-751 Standard anti-rotation bracket 9" long x 13/16" wide (229 x 21 mm), included with actuator
- AM-752 Optional anti-rotation bracket 4" long x 1-11/6" wide (102 x 43 mm), for narrow spaces
- AM-753 Optional universal mounting clamps for 5/8"(16 mm) square shaft, 3/4" and 1" (19 to 25 mm) round shafts (two per package)
- AM-754 Standard universal mounting clamps for 3/8" to 1/2" (10 to 13 mm) round and square shafts, two included with actuator
- AM-756 Metric conduit adaptor M20 x 1.5 to 1/2" NPT (two per package)
- AV-607 Dual mount rack and pinion valve linkage kit for 2-1/2" through 5" VB-8xxx series valve bodies and 2-1/2" to 4" VB-9xxx series valve bodies except VB-9323
- AV-609 Dual mount rack and pinion valve linkage kit for 6" VB-8xxx series valve bodies and 5" and 6" VB-9xxx series valve bodies except VB-9323
- TF-711-02 1/2" Sealtight water tight conduit connector (straight)
- TF-713-02 1/2" Sealtight water tight conduit connector (90°)
- X-5521 1/2" Pipe plug, included with actuator

TYPICAL APPLICATIONS (wiring diagrams)

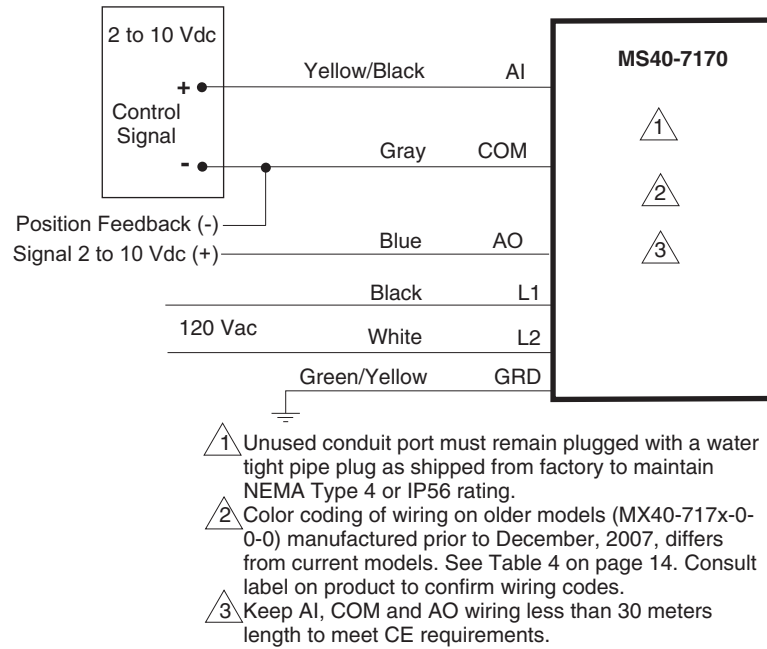

Figure-1 Typical MS40-7170 2 to 10 Vdc Wiring Diagram.

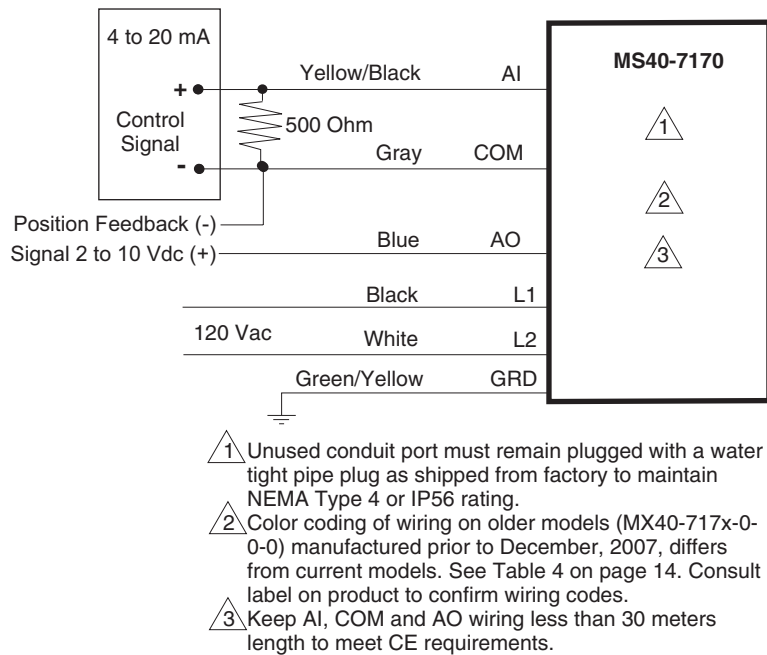
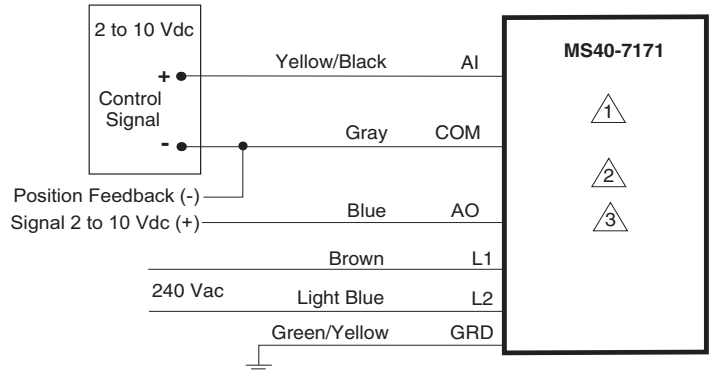
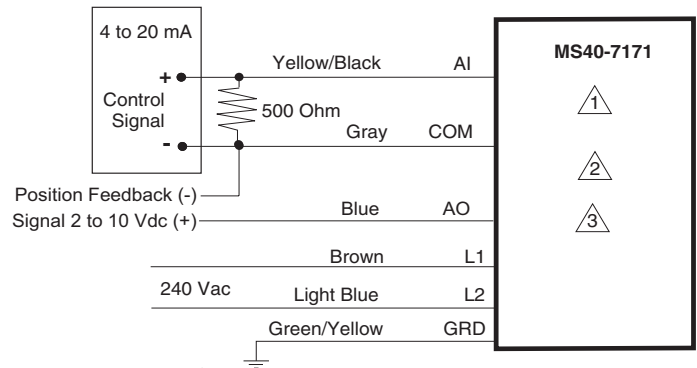

Figure-2 Typical MS40-7170 4 to 20 mA Wiring Diagram.



- 1 Unused conduit port must remain plugged with a water tight pipe plug as shipped from factory to maintain NEMA Type 4 or IP56 rating.
- 2 Color coding of wiring on older models (MX40-717x-0-0-0) manufactured prior to December, 2007, differs from current models. See Table 4 on page 14. Consult label on product to confirm wiring codes.
- 3 Keep AI, COM and AO wiring less than 30 meters length to meet CE requirements.

Figure-3 Typical MS40-7171 2 to 10 Vdc Wiring Diagram.



- 1 Unused conduit port must remain plugged with a water tight pipe plug as shipped from factory to maintain NEMA Type 4 or IP56 rating.
- 2 Color coding of wiring on older models (MX40-717x-0-0-0) manufactured prior to December, 2007, differs from current models. See Table 4 on page 14. Consult label on product to confirm wiring codes.
- 3 Keep AI, COM and AO wiring less than 30 meters length to meet CE requirements.

Figure-4 Typical MS40-7171 4 to 20 mA Wiring Diagram.

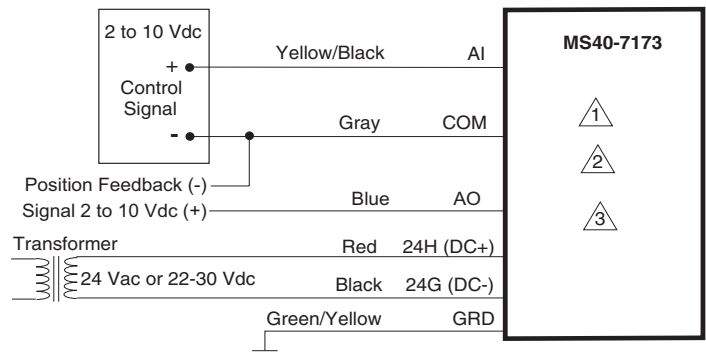

- 1 Unused conduit port must remain plugged with a water tight pipe plug as shipped from factory to maintain NEMA Type 4 or IP56 rating.
- 2 Color coding of wiring on older models (MX40-717x-0-0-0) manufactured prior to December, 2007, differs from current models. See Table 4 on page 14. Consult label on product to confirm wiring codes.
- 3 Keep AI, COM and AO wiring less than 30 meters length to meet CE requirements.

Figure-5 Typical MS40-7173 2 to 10 Vdc Wiring Diagram.

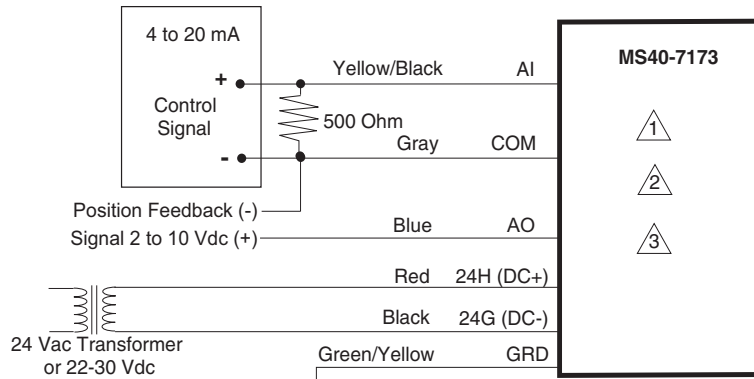

- 1 Unused conduit port must remain plugged with a water tight pipe plug as shipped from factory to maintain NEMA Type 4 or IP56 rating.
- 2 Color coding of wiring on older models (MX40-717x-0-0-0) manufactured prior to December, 2007, differs from current models. See Table 4 on page 14. Consult label on product to confirm wiring codes.
- 3 Keep AI, COM and AO wiring less than 30 meters length to meet CE requirements.

Figure-6 Typical MS40-7173 4 to 20 mA Wiring Diagram.

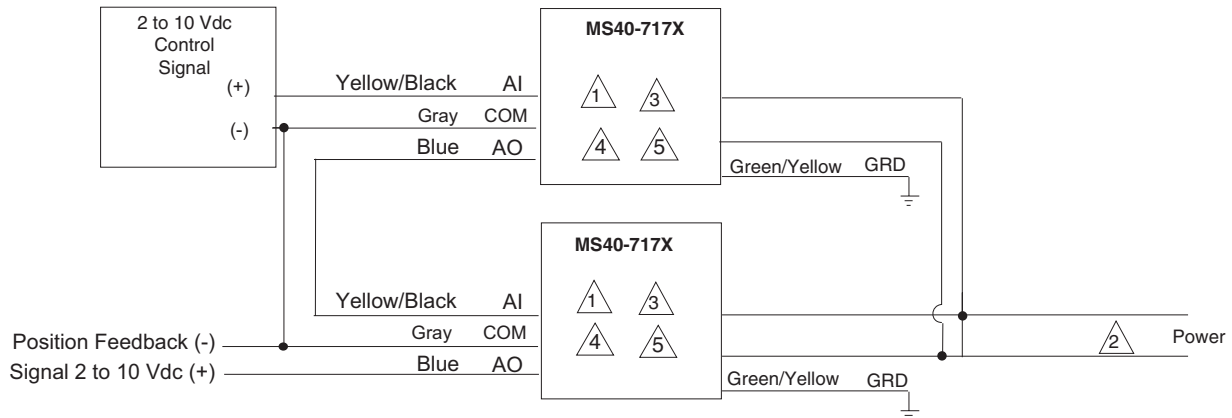

- 1 Unused conduit port must remain plugged with a water tight pipe plug as shipped from factory to maintain NEMA Type 4 or IP56 rating.
- 2 See table for power wire designations.
- 3 Both actuators must be set to operate in the same direction.
- 4 Color coding of wiring on older models (MX40-717x-0-0-0) manufactured prior to December, 2007, differs from current models. See Table 4 on page 14. Consult label on product to confirm wiring codes.
- 5 Keep AI, COM and AO wiring less than 30 meters length to meet CE requirements.

Power Wiring Identification.

Voltage	Designation	Wire Color
24 Vac or 22-30 Vdc	24H (DC+)	Red
	24G (DC-)	Black
120 Vac	L1	Black
	L2	White
240 Vac	L1	Brown
	L2	Light Blue

Figure-7 Two Actuators on the Same Damper Shaft.

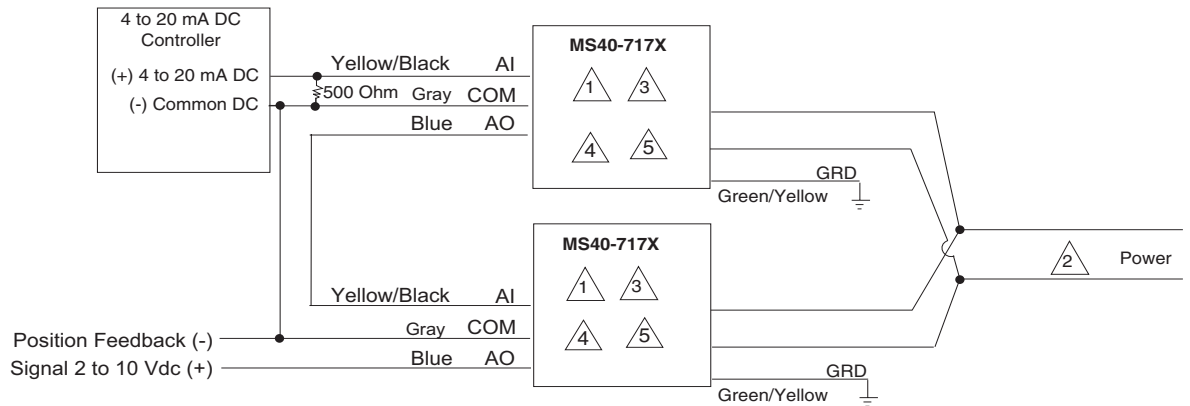

- 1 Unused conduit port must remain plugged with a water tight pipe plug as shipped from factory to maintain NEMA Type 4 or IP56 rating.
- 2 See table for power wire designations.
- 3 Both actuators must be set to operate in the same direction.
- 4 Color coding of wiring on older models (MX40-717x-0-0-0) manufactured prior to December, 2007, differs from current models. See Table 4 on page 14. Consult label on product to confirm wiring codes.
- 5 Keep AI, COM and AO wiring less than 30 meters length to meet CE requirements.

Power Wiring Identification.

Voltage	Designation	Wire Color
24 Vac or 22-30 Vdc	24H (DC+)	Red
	24G (DC-)	Black
120 Vac	L1	Black
	L2	White
240 Vac	L1	Brown
	L2	Light Blue

Figure-8 Typical 4 to 20 mAdc Control Wiring For Two Actuators On The Same Damper Shaft.

INSTALLATION

Inspection

Inspect the package for damage. If damaged, notify the appropriate carrier immediately. If undamaged, open the package and inspect the device for obvious damage. Return damaged products.

Requirements

- Job wiring diagrams
- Tools (not provided)
 - Socket wrench 1/2 inch, used for universal mounting clamp nuts
 - Open-end wrench 10 mm, used for installing AM-676 universal shaft extension
 - Slotted screwdriver, used for installing anti-rotation brackets
 - Allen wrench 3/16", used for manual override
- Appropriate accessories
 - Water tight 1/2 inch conduit seals TAC part number TF-711-02 or T&B #5332 (straight, TAC part number TF-713-02 or T&B #5352 (90°), or equivalent.
 - Water tight 1/2 inch flexible conduit (e.g. Anaconda: Sealtight) or 20 mm flexible water tight conduit when using AM-756 metric conduit adapter with appropriate metric water tight seals.
 - Water tight 1/2" flexible conduit (Anaconda: Sealtight) or 20 mm flexible water tight conduit when using AM-756 metric conduit adaptor
 - Two #8 1/2" (13 mm) sheet metal screws for mounting (optional)
- Training: Installer must be a qualified, experienced technician

Precautions



General

Warning:

- Electrical shock hazard! Disconnect the power supply (line power) before and during installation to prevent electric shock and equipment damage.
 - Make all connections in accordance with the wiring diagram and in accordance with national and local electrical codes. *Use copper conductors only.*
-

Caution:

- Avoid electrical noise interference. Do not install near large contactors, electrical machinery, or welding equipment.
 - Avoid locations where excessive moisture, corrosive fumes, vibration, or explosive vapors are present.
-

Federal Communications Commission (FCC)

Note: This equipment has been tested and found to comply with the limits for a Class B digital device, pursuant to Part 15 of the FCC Rules. These limits are designed to provide reasonable protection against harmful interference in residential installations. This equipment generates, uses, and can radiate radio frequency energy and may cause harmful interference if not installed and used in accordance with the instructions. Even when instructions are followed, there is no guarantee that interference will not occur in a particular installation. If this equipment causes harmful interference to radio or television reception—which can be determined by turning the equipment off and on—the user is encouraged to try to correct the interference by one or more of the following measures:

- Reorient or relocate the receiving antenna.
 - Increase the separation between the equipment and receiver.
 - Connect the equipment to an outlet on a circuit different from that to which the receiver is connected.
 - Consult the dealer or an experienced radio/television technician for help.
-

Canadian Department of Communications (DOC)

Note: This class B digital apparatus meets all requirements of the Canadian Interference-Causing Equipment Regulations.

Cet appareil numérique de la classe B respecte toutes les exigences du Règlement sur le matériel brouilleur du Canada.

European Standard EN 55022

Warning: This is a class B (European Classification) product. In a domestic environment this product may cause radio interference in which case the user may be required to take adequate measures.

Caution:

- To maintain NEMA Type 4 rating, use water tight 1/2" flexible conduit only, with 1/2" conduit connector of the water tight type, TAC part number TF-711-02 or T&B #5332 (straight), TAC part number TF-713-02 or T&B #5352 (90°), or equivalent.
 - For metric conduit applications using AM-756 conduit adapters, use the appropriate metric water tight seals to maintain compliance with IP56 or NEMA Type 4 rating.
 - Use a water tight 1/2" pipe plug in any unused actuator conduit ports and seal with water tight tape to stay in compliance with NEMA Type 4 or IP56 rating. Use TAC part number X-5521, Grinnell #8700159257 (black), Grinnell #8700159851 (galvanized), or equivalent. Actuators with unused conduit ports are shipped with the unused port plugged.
-

Location

Mounting

Mount the TAC DuraDrive Actuator directly on the damper shaft in locations that clear the maximum dimensions of the actuator case and allow the actuator to be mounted flush to the surface of the terminal box and perpendicular to the damper shaft.

Note: Some terminal boxes have sheet metal screw heads or other protrusions near the damper shaft. In these cases, a spacer or shim may be added under the mounting tab of the actuator to make the actuator perpendicular to the shaft.

Caution: To remain in NEMA 2 compliance the MS40-715X and MS40-707X series actuators should be mounted with conduit end down.

Damper Actuator Sizing

Correct sizing of the actuator is necessary for proper control of dampers. The area of damper that can be controlled by a given actuator is dependent upon the quality of the damper, the pressure drop across the damper in the closed position, and the velocity of the air flow through the damper. To obtain actual damper torque requirements, contact the damper manufacturer.

Damper Shaft Sizing

Use the "Long Damper Shaft" mounting instructions if the damper shaft is at least 4-5/8" (117 mm) long.

Use the "Short Damper Shaft" mounting instructions if the damper shaft is shorter than 4-5/8" or the area around the damper shaft is too narrow to allow standard mounting, as described in the "Long Damper Shaft" mounting section. See Figure-9 for minimum shaft length.

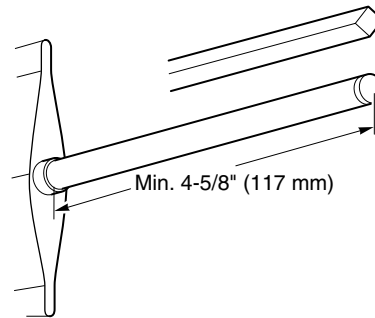

Figure-9 Long Damper Shaft Dimensions.

Caution: The MS40-717X actuator is not designed to be used on aluminum damper shafts, solid steel shafts smaller than 1/2" diameter round or 1/2" square, or hollow steel shafts smaller than 3/4" round. The actuator can produce up to 545 in-lbs (61.8 N-m) maximum stall torque, which could result in the actuator snapping off an aluminum damper shaft or an improperly sized steel damper shaft. Refer to Table-2 for nominal damper shaft sizes.

Table-2 Steel Damper Shaft Specifications.

Damper Shaft Shape	Damper Shaft Type	O.D. (Nominal) ^a	I.D. (Maximum)
Round	Solid bar	1/2" to 1"	0
	Hollow tubing	3/4"	0.375
		13/16"	0.683
		27/32"	0.626
		7/8"	0.805
		15/16"	0.808
	1"	0.930	
Square	Solid bar	1/2" to 5/8"	0

^a Damper shaft sizes over 1/2" (13 mm) O.D. require AM-753 universal mounting clamps.

Mounting the Actuator for Clockwise or Counterclockwise Dampers

The zero (0) position on the position indicator is the normal or spring return position. When the actuator is mounted with the “R” side facing the installer and the control signal increases the actuator will rotate in the counterclockwise direction. When the actuator is mounted with the “L” side facing the installer and the control signal increases the actuator will rotate in the clockwise direction.

Long Damper Shafts

1. Move the damper to its normal position. Verify the controller action is set to match the damper application (normally closed or normally open). See TYPICAL APPLICATIONS (wiring diagrams).
 - For normally closed damper, when damper is closed the actuator position indicator should be at 0°. When damper is open the actuator position indicator should be at 90°.
 - For normally opened damper, when damper is open the actuator position indicator should be at 0°. When damper is closed the actuator position indicator should be at 90°.

Note: The actuator comes equipped with two AM-754 universal mounting clamps. For damper shafts larger than 1/2" (13 mm) in diameter, the AM-753 universal mounting clamps are required (order separately). The AM-753 clamps accommodate round shaft sizes ranging from 3/4" to 1" (19 to 25 mm) or 5/8" (16 mm) square shafts.

2. Slide the actuator over the shaft and into its desired final mounting position.
 - If the damper shaft rotates clockwise to the closed position, mount the actuator with the side marked “R” facing the installer. See Figure-10.
 - If the damper shaft rotates counterclockwise to the closed position, mount the actuator with the side marked “L” facing the installer. See Figure-11.
3. Hand tighten the nuts on both of the actuator’s universal mounting clamps.
4. Align the actuator at 90° (perpendicular) to the damper shaft. See Figure-12.
5. Slide the anti-rotation bracket pin into the mounting slot on the actuator and drill mounting holes. See Figure-12. For narrow spaces the AM-752 anti-rotation bracket is recommended (order separately).
6. Attach one side of the anti-rotation bracket to the mounting surface with one of the screws provided. Leave the screw loose so that the bracket can be rotated. See Figure-10 for clockwise or Figure-11 for counterclockwise spring return.
7. Pivot the anti-rotation bracket away from the actuator. See Figure-10 or Figure-11.
8. Loosen the universal mounting clamps, making sure not to move the damper shaft. Rotate the actuator approximately 5° in the direction which would open the damper. See Figure-10 or Figure-11.
9. Tighten all of the universal mounting clamp nuts with a 1/2" socket wrench. Apply 4 to 6 ft -lbs (5 to 8 N-m) of torque.
10. Manually rotate the actuator toward the full-closed position to apply pressure to the damper seals. See Figure-10 or Figure-11.
11. Pivot the anti-rotation bracket into place and secure the other side of the bracket onto the mounting surface using the other screw provided with the actuator. See Figure-10 or Figure-11.
12. Verify that the damper is in its full-closed position and actuator at 90° (perpendicular) to the damper shaft. See Figure-10 or Figure-11.

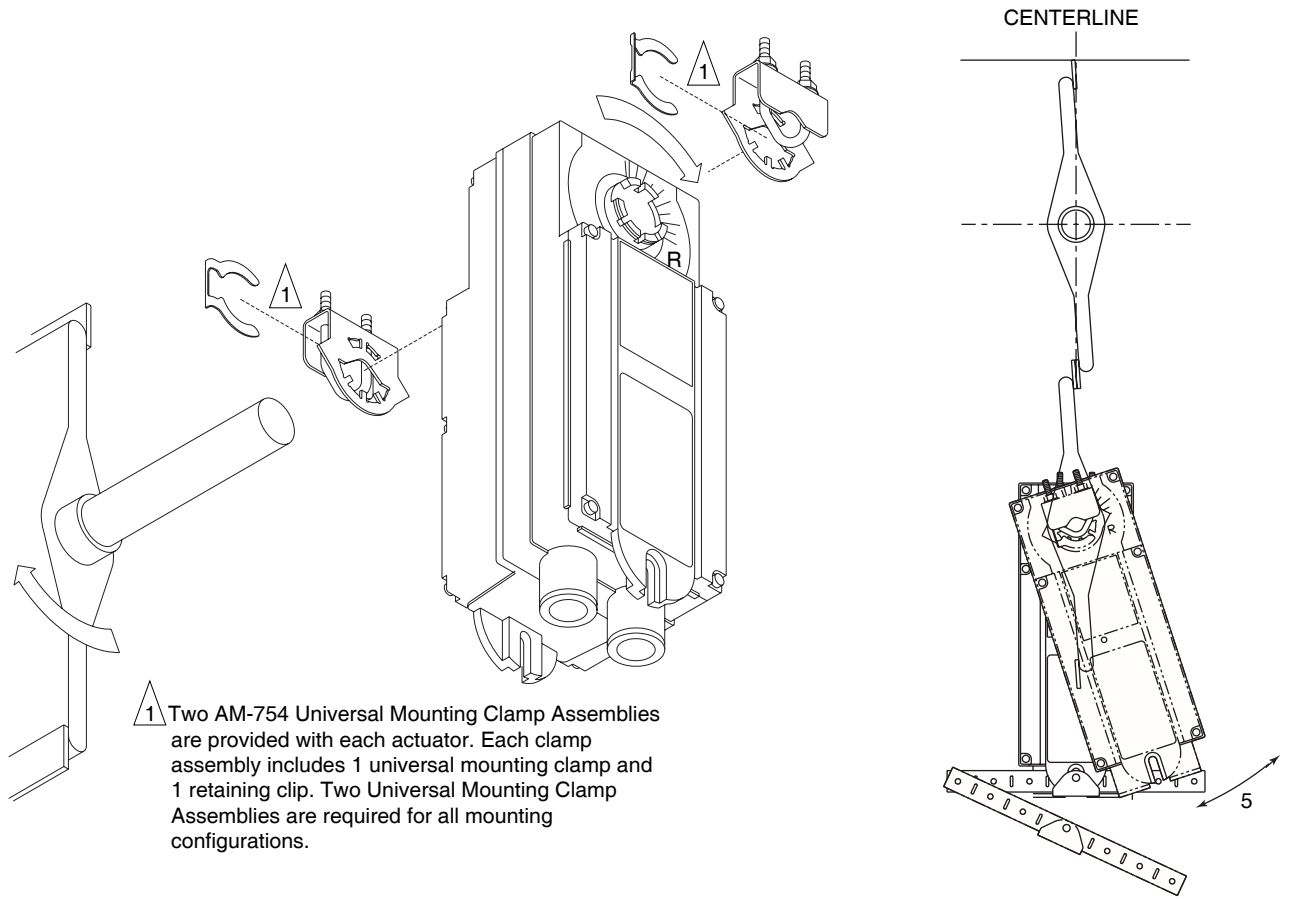

1 Two AM-754 Universal Mounting Clamp Assemblies are provided with each actuator. Each clamp assembly includes 1 universal mounting clamp and 1 retaining clip. Two Universal Mounting Clamp Assemblies are required for all mounting configurations.

Figure-10 Long Damper Shaft Mounting with Clockwise Spring Return for Normally Closed Damper.

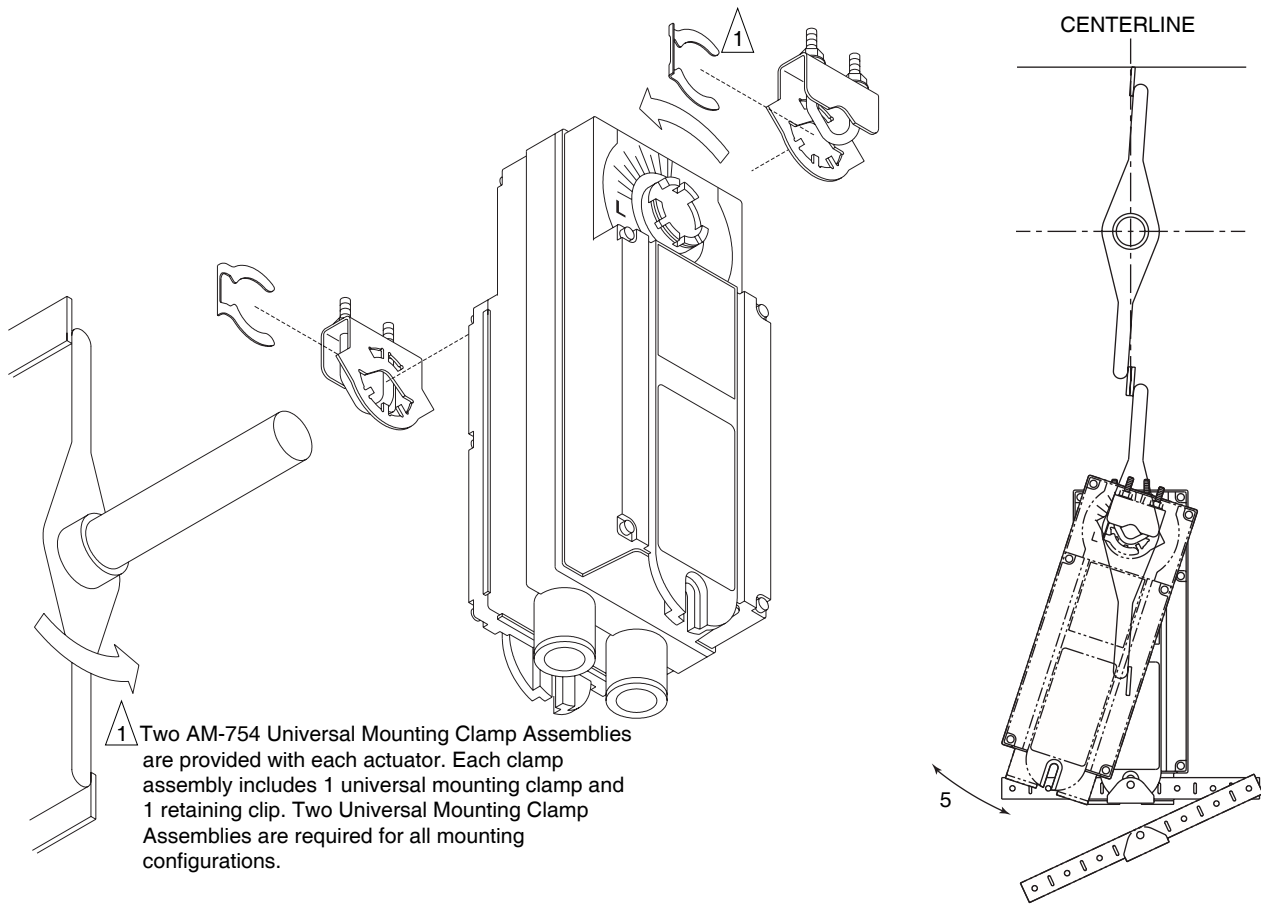

Figure-11 Long Damper Shaft Mounting with Counterclockwise Spring Return for Normally Closed Damper.

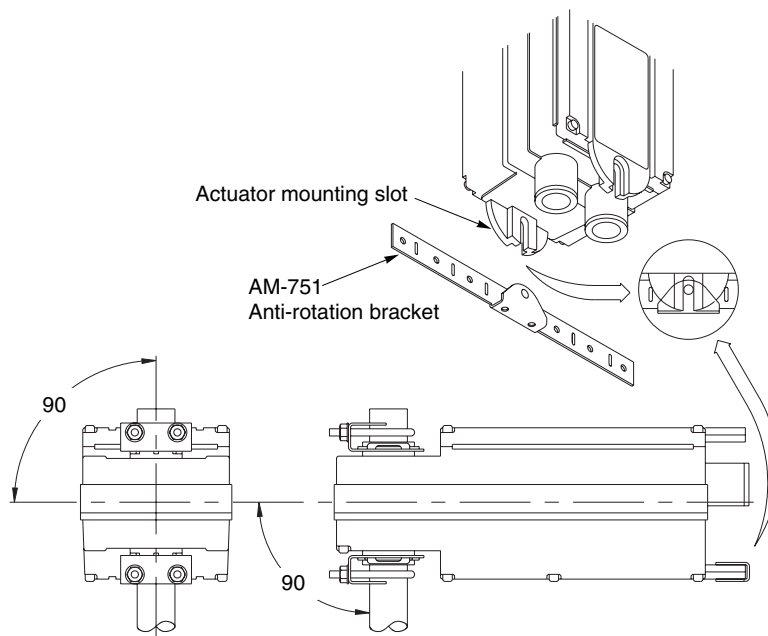

Figure-12 Mounting Anti-rotation Bracket to Actuator.

Short Damper Shafts

See Figure-13 for installation of actuator using the AM-676 Universal Shaft Extension. Installation requires AM-676 Universal Shaft Extension and AM-753 Universal Mounting Clamps for 3/4" to 1" (19 to 25 mm) shafts, these items must be ordered separately.

1. Loosen the V-clamp nuts on the AM-676 universal shaft extension.
2. Fit the universal shaft extension fully onto the damper shaft. Tighten the universal shaft extension V-clamp nuts with a 10 mm open-end wrench. Apply 4 to 6 ft. lbs (5 to 8 N-m) of torque.
3. Move the damper to its normal position. Verify the controller action is set to match the damper application. See TYPICAL APPLICATIONS (wiring diagrams).
 - For normally closed damper: when damper is closed, actuator position indicator should be at 0°. When damper is open, actuator position indicator should be at 90°.
 - For normally opened damper: when damper is open, actuator position indicator should be at 0°. When damper is closed, actuator position indicator should be at 90°.
4. Remove the mounting clamps from the actuator and replace them with the AM-753 universal mounting clamps.
5. Loosen the nuts on both of the AM-753 universal mounting clamps on the damper actuator.
 - If the damper shaft rotates clockwise to the closed position, mount the actuator with the side marked "R" facing the installer. See Figure-10.
 - If the damper shaft rotates counterclockwise to the closed position, mount the actuator with the side marked "L" facing the installer. See Figure-11.
6. Assemble the damper actuator onto the universal shaft extension, allowing the extension to slide through the actuator's universal mounting clamps. Make sure the actuator is 90° (perpendicular) to the damper shaft. Then, hand tighten the nuts on both of the actuator's universal mounting clamps. See Figure-12

Note: If the universal shaft extension protrudes excessively above the damper actuator's top universal mounting clamp:

- remove the damper actuator from the universal shaft extension,
 - remove the extension from the damper shaft,
 - shorten the universal shaft extension by cutting it to the desired length,
 - then proceed to follow mounting instructions.
-

7. Slide the anti-rotation bracket pin into the mounting slot on the actuator. See Figure-12. For narrow spaces, the AM-752 anti-rotation bracket is recommended (order separately).
8. Position the actuator and bracket in the desired final mounting position on the mounting surface and drill mounting holes. See Figure-13.
9. Attach one side of the anti-rotation bracket to the mounting surface with one of the screws provided. Leave the screw loose so that the bracket can be rotated. See Figure-10 for clockwise or Figure-11 for counterclockwise spring return.
10. Pivot the anti-rotation bracket away from the actuator. See Figure-10 or Figure-11.
11. Loosen the universal mounting clamps, making sure not to move the damper shaft. Rotate the actuator approximately 5° in the direction which would open the damper. See Figure-10 or Figure-11.
12. Tighten all of the universal mounting clamp nuts with a 1/2" socket wrench. Apply 4 to 6 ft-lbs (5 to 8 N-m) of torque.
13. Manually rotate the actuator toward the full-closed position to apply pressure to the damper seals. See Figure-10 or Figure-11.
14. Pivot the anti-rotation bracket into place and secure the other side of the bracket onto the mounting surface using the other screw provided with the actuator. See Figure-10 or Figure-11.
15. Verify that the damper is in its full-closed position and actuator at 90° (perpendicular) to the damper shaft. See Figure-10 or Figure-11.

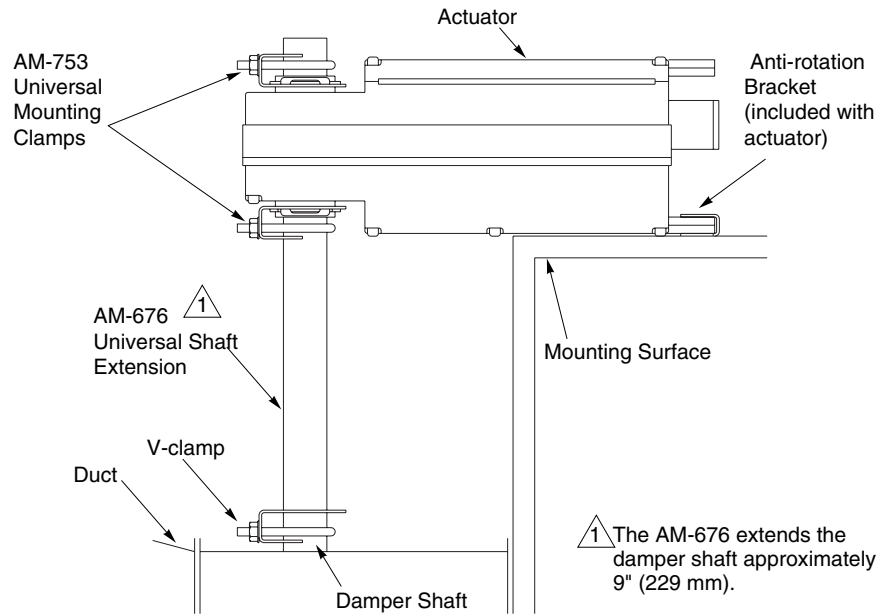

Figure-13 Installation of Universal Shaft Extension.

Wiring Requirements

Control and Power Leads

Remove blue plastic thread protectors before installing conduit fittings. See Figure-1 through Figure 8 for typical wiring applications and Table-3 for maximum wire lengths.

Caution: The 24 Vac model contains a half-wave rectifier power supply and must not be powered by transformers used to power other devices utilizing non-isolated full-wave rectifier power supplies. Refer to *EN-206 Guidelines for Powering Multiple Full-Wave and Half-Wave Rectifier Devices from a Common Transformer*, F-26363, for further information.

Note: Class 2 control and power lead wiring must be routed separately from line voltage wiring and any other non-class 2 circuits.

Table-3 Control and Power Wiring Data.

Actuator Voltage	Part Number	Maximum Wire Run in ft. (m) (5% Voltage Drop)		
		14 AWG	16 AWG	18 AWG
24 Vac and 22-30 Vdc	MS40-7173	981 (299)	617 (188)	388 (118)
120 Vac	MS40-7170			
240 Vac	MS40-7171			

Table-4 Wire Color Codes for Models Manufactured before December, 2007.

Part Number	Power Voltage	L1	L2	Ground	24 H	24 G	Analog Input	500 Ohms	Common
MS40-7173-0-0-0 Old Design	24 Vac	N/A	N/A	Green/Yellow	Black	Black/Blue	White	Red	Black
MS40-7170-0-0-0 Old Design	120 Vac	Black	White	Green/Yellow	N/A	N/A	White	Red	Black
MS40-7171-0-0-0 Old Design	240 Vac	Brown	Light Blue	Green/Yellow	N/A	N/A	White	Red	Black

N/A: Not Applicable

CHECKOUT

This procedure is for checking out a normally closed actuator that is typically mounted unpowered. It is possible to mount the actuator with power applied for special applications.

Note: To check out a normally opened actuator the procedure is the same as below, except the initial position is open and closed when powered.

After the entire system has been installed and the actuator has been powered up, the following check can be made for proper system operation. Check for correct operation of the damper while actuator is being stroked.

1. Apply power to the actuator and control system.
2. Set the controller to cause the actuator to drive open (set override controller output to maximum).
3. Check to see that the actuator travels to the full-open position.
4. Set the controller to cause the actuator to drive closed (set override controller output to minimum).
5. Check to see that the actuator travels to the fully closed position.

Note: If anticipated damper operation does not occur, verify the Long Damper Shaft or Short Damper Shaft mounting procedures. Also, verify that the controller has the proper action (direct or reverse) to match the damper required operation.

THEORY OF OPERATION

The actuator is, by means of dual mounting clamps, directly mounted onto the damper shaft. The anti-rotation bracket supplied with the actuator prevents lateral movement of the actuator. The damper actuator is not provided with and does not require any limiting switches, but is electronically protected against overloading.

The angle of rotation is electronically limited to $92^{\circ} \pm 1^{\circ}$. When reaching the damper or actuator end position, the motor stops automatically. The position of the actuator is indicated by means of scale reading 0 to 95° .

MAINTENANCE

Regular maintenance of the total system is recommended to assure sustained optimum performance. The MS40-717X actuator is maintenance free.

FIELD REPAIR

None. Replace with functional actuator.

DIMENSIONAL DATA

Figure-14 dimensions are in inches (mm).

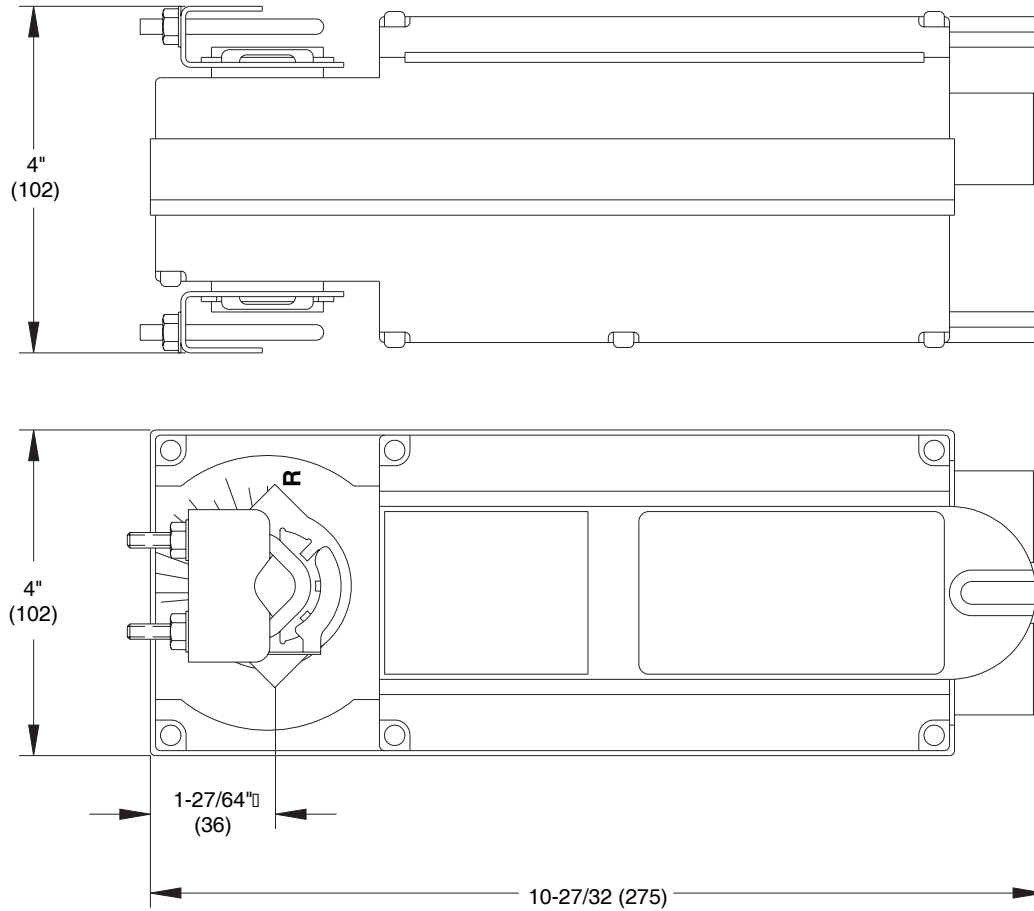

Figure-14 MS40-717X Damper Actuator.

Copyright 2007, TAC
All brand names, trademarks and registered
trademarks are the property of their respective
owners. Information contained within this
document is subject to change without notice.

TAC
1354 Clifford Avenue
P.O. Box 2940
Loves Park, IL 61132-2940

F-26748-4