

VarPlus Logic has all what you need for the simple and efficient operation of your automatic power factor correction equipment to maintain your power factor. It is a simple and intelligent relay which measure, monitor and controls the reactive energy. Easy commissioning, step size detection and monitoring makes it different from others in the market.

DB417842 Presentation eps



VarPlus Logic VL6, VL12

Capacitor bank step monitoring

- Monitoring of all the connected capacitor steps.
- Real time power in “kvar” for the connected steps .
- Remaining step capacity per step as a % of the original power since installation.
- Remaining step power in kvar since installation.
- Number of switching operations of every connected step.

System Measurement and monitoring

- THD(u) and THD(u) Spectrum 3rd to 19th – Measurement, Display and Alarm.
- Measurement of DQ – “kvar” required to achieve target cos phi.
- Present cabinet temperature and maximum recorded temperature.
- System parameters – Voltage, Current, Active, reactive and apparent power.
- Large LCD display to monitor real step status and other parameters.

Easy Commissioning

- Automatic Initialization and automatic step detection to do a auto commissioning.
- Automatic wiring correction - voltage and current input wiring correction.
- 1A or 5A CT secondary compatible.

Flexibility to the panel builder and retrofitting

- No step sequence restriction like in the traditional relays.
- Any step sequences with auto detect. No programming needed.
- Easy to retrofit the faulty capacitor with different power.
- Quick and simple mounting and wiring.
- Connect to the digitized Schneider solutions through RS485 communication in Modbus protocol.
- Seamless connection to the Schneider software and gateways.

Do more with VarPlus Logic

- Programmable alarms with last 5 alarms log.
- Suitable for medium voltage applications.
- Suitable for 4 quadrant operations.
- Dual cos phi control through digital inputs or export power detection.
- Dedicated alarm and fan control relays.
- Advance expert programming Menu to configure the controller the way you need.
- New control algorithm designed to reduce the number of switching operations and quickly attain the targeted power fact

Alarms

- Faulty Step
- Configurable alarm for step derating
- THDu Limit alarm.
- Temperature alarm
- Self correction by switching off the steps at the event of THDu alarm, temperature alarm and overload limit alarm.
- Under compensation alarm
- Under/Over Voltage Alarm
- Low/High Current Alarm
- Overload limit alarm
- Hunting alarm
- Maximum operational limits - Time and number of switching

Range

Type	Number of step output contacts	Part number
VL6	06	VPL06N
VL12	12	VPL12N

Phase-to-Neutral with VTs (3PH4W)

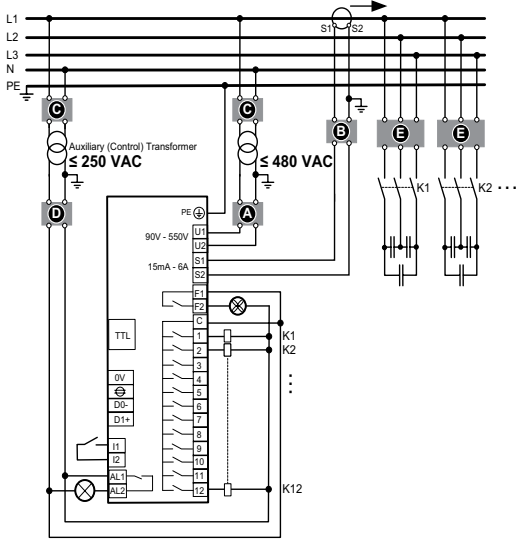

Phase-to-Phase with VTs (3PH3W)

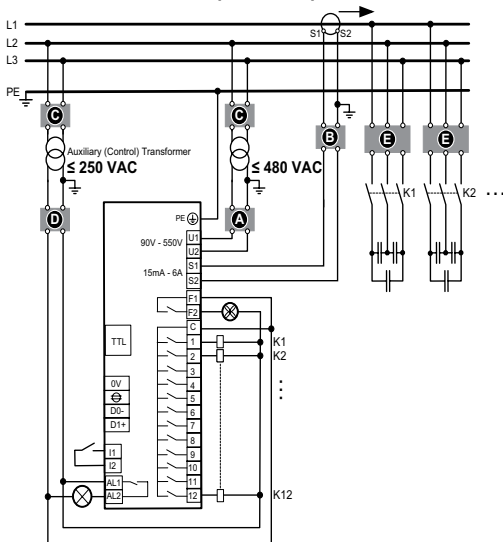

- A** Upstream protection
Voltage input: 2A certified circuit breakers or fuses
- B** Shorting block for CT
- C** VT primary fuses and disconnect switch
- D** Output relays: 10 A (max.) certified circuit breakers or fuses (Applicable for applications with voltage transformers only).
- E** Capacitor primary fuses or CB's

General characteristics

Voltage and current Input

Direct supply voltage	90 – 550 V, 1ph, 50/60 Hz
	VA Burden: 6 VA
	300 V LN / 519 V LL CAT III or 550 V CAT II
Type of input connection	Phase to phase or phase to neutral
Protection against voltage dips	Automatic disconnection of steps for dips > 15 ms (protection of capacitor)
CT secondary	1A or 5A compatible
CT primary range	Up to 9600 A
Current	15 mA – 6 A, 1PH, VA Burden : < 1 VA
Connection terminals	Screw type, pluggable. Section: 0.2 – 2.5 mm ² (0.2 – 1 mm ² for Modbus and digital inputs)

Power factor settings & algorithm selection

Regulation setting - Programmable	From Cos Phi 0.7c to 0.7i
Reconnection time - Programmable	From 1 to 6500 s
Response time - Programmable	From 1 to 6500 s
Possibility of dual cos Phi target	Yes, through digital input or if export power detected
Program algorithm	AUTOMATIC (best fit) - Default
	LIFO
	PROGRESSIVE
Import export application compatibility	4- Quadrant operation for generator application

Program intelligence

Automatic Initialization and Automatic bank detection	Yes
Detection and display of power, number of switching & derating of all connected steps	Yes
Capacitor bank step sequence	Any sequence. No restriction/limitation on sequence

Alarm and control

Control outputs (step output)	VL6: 6 relays VL12: 12 relays (NO contact) 250 V LN or LL (CAT III) DC Rating : 48 V DC / 1 A AC Rating : 250 V AC / 5 A Common root: 10 A max.
Dedicated fan control relay	Yes. Normal open contact (NO) 48 V DC / 1 A, 250 V AC / 5 A
Alarm contact	The relay contact is open when the controller is energized with no alarm and will close in the event of an alarm. The relay is a NC (Normally Close) when the controller is not energized. Rating : 48 V DC / 1 A, 250 V AC / 5 A
Digital input for Cos phi2 target	Dry contact (internal supply 5 V, 10 mA)
Modbus RS-485 serial port (RTU)	Line polarization / termination, not included
Communication protocol	Modbus
Interface TTL	Service port. Only for internal use
Internal temperature probe	Yes. Temperature offset is programmable.

General characteristics

Display and measurement

Display	LCD graphic 56 x 25
Alarms log	5 last alarms
Voltage Harmonic Distortion measurement	THDu ; Individual odd harmonics distortion from H3 to H19
Measurement displayed and accuracy	Voltage, Current & Frequency: $\pm 1\%$ Energy measurements, Cos Phi, THD(u): $\pm 2\%$ Individual Voltage harmonics (H3 to H19): $\pm 3\%$ Temperature measurement : $\pm 3\text{ }^{\circ}\text{C}$

Testing standards and conformities

Standards	IEC 61010-1 IEC 61000 6-2 IEC 61000 6-4 IEC 61326-1 UL 61010
Conformity and listing	Conformity and listing CE, NRTL, c NRTL, EAC

Mechanical specifications

Case	Front: Instrument case plastic RAL 7016 Rear: Metal
Degree of Protection	Front: IP41, (IP54 by using a gasket) Rear: IP20
Weight	0.6 kg
Size	144 x 144 x 58 mm (H x W x D)
Panel Cutout	138 x 138 (+0.5) mm, thickness 1 – 3 mm
Panel Mounting	Flush mounting

Storage condition

Temperature for operation	-20 °C +60 °C
Storage	-40 °C +85 °C
Humidity	0 % - 95 %, without condensation for operation and storage
Maximum pollution degree	2
Maximum altitude	$\leq 2000\text{m}$

Dimensions

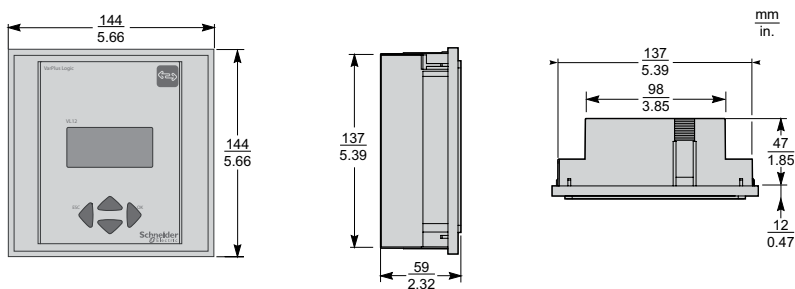

Mounting

