

# Altistart™ 48

## Enclosed Soft Start Controllers

1–600 hp, 600 V; 1–500 hp, 480 V;  
1–250 hp, 240 V or 1–200 hp, 208 V  
Class 8638 and 8639

Instruction Bulletin

30072-450-62

Rev. 02, 02/2014

Retain for future use.



## Hazard Categories and Special Symbols

Read these instructions carefully and look at the equipment to become familiar with the device before trying to install, operate, service, or maintain it. The following special messages may appear throughout this bulletin or on the equipment to warn of hazards or to call attention to information that clarifies or simplifies a procedure.



The addition of either symbol to a “Danger” or “Warning” safety label indicates that an electrical hazard exists which will result in personal injury if the instructions are not followed.



This is the safety alert symbol. It is used to alert you to personal injury hazards. Obey all safety messages that follow this symbol to avoid possible injury or death.

### **DANGER**

**DANGER** indicates a hazardous situation which, if not avoided, **will result in death or serious injury**.

### **WARNING**

**WARNING** indicates a hazardous situation which, if not avoided, **can result in death or serious injury**.

### **CAUTION**

**CAUTION** indicates a hazardous situation which, if not avoided, **can result in minor or moderate injury**.

### **NOTICE**

**NOTICE** is used to address practices not related to physical injury. The safety alert symbol is not used with this signal word.

**NOTE:** Provides additional information to clarify or simplify a procedure.

## Please Note

Electrical equipment should be installed, operated, serviced, and maintained only by qualified personnel. No responsibility is assumed by Schneider Electric for any consequences arising out of the use of this material.

---

<b>SECTION 1: INTRODUCTION AND TECHNICAL CHARACTERISTICS</b>	5
Introduction	5
Related Documentation	5
Exceptions to Bulletin S1A37491	5
Terminology	6
Standard Features	6
Before You Begin	6
Technical Specifications	9
Controller Nameplate	11
Catalog Number Identification	11
Form Designations	12
<b>SECTION 2: RECEIVING, HANDLING, AND STORAGE</b>	13
Receiving and Preliminary Inspection	13
Before Installation	13
Handling the Controller	14
<b>SECTION 3: INSTALLATION</b>	15
Precautions	15
Seismic Qualification Mounting Criteria	15
Mounting Dimensions and Weights	17
Wiring	31
Grounding	31
Control Wiring	33
Load Wiring	33
Adaptation to Line Input	33
<b>SECTION 4: OPERATION</b>	35
Circuit Diagrams	35
Integrated Full Voltage Bypass Starter (MOD A10)	35
Factory Settings	36
Minimum Start-up Procedure	37
Nominal Motor Current (In)	37
Motor Overload Relay (MOD A10 only)	38
<b>SECTION 5: MAINTENANCE</b>	39
Before You Begin	39
Power Fuse Recommendation	41
Technical Support	44
<b>SECTION 6: REPLACEMENT PARTS</b>	47



## Section 1—Introduction And Technical Characteristics

### Introduction

This instruction bulletin is a supplement to the *Altistart™ 48 Y-Range Soft Start Controller Installation Guide*, S1A37491.<sup>1</sup> This bulletin provides installation and maintenance information for the Altistart 48 (ATS48) Enclosed Soft Start Controllers. ATS48 Enclosed Soft Start Controllers are combination devices available with a fusible disconnect (Class 8638) or with a circuit breaker (Class 8639).

### Related Documentation

In addition to this bulletin, refer to the following documentation which ships with the ATS48 Enclosed Soft Start Controllers:

- Elementary diagrams that illustrate power, control, and optional circuits of the controller.
- Outline dimensional drawings that identify the physical characteristics of the controller and contain installation information.
- Instruction bulletin S1A37491, *Altistart 48 Y-Range Soft Start Controller Installation Guide*, describes the installation, operation, and characteristics of the ATS48 soft start when used as a component of the Class 8638 or Class 8639 ATS48 Enclosed controllers.
- Instruction bulletin 30072-200-50\_\_, *Safe Handling, Installation, Operation, and Maintenance of Electrical Equipment*.

**NOTE:** To replace missing documents, contact your local Schneider Electric field office.

### Exceptions to Bulletin S1A37491

Certain information in the related documentation replaces information provided in bulletin S1A37491. When referencing this instruction bulletin, note the following exceptions:

- “Minimum Start-Up Procedure” on page 37 of this bulletin replaces the “Quick Start Procedure” section of bulletin S1A37491.
- “Receiving, Handling, and Storage” on page 13 of this bulletin replaces the “Receiving and Handling” section of bulletin S1A37491.
- “Mounting” in bulletin S1A37491 is not applicable to the ATS48 Enclosed controller. For information about installing the controller, refer to the “Installation” section on page 15 of this bulletin.
- “Recommended Component Lists” in bulletin S1A37491 applies to open ATS48 soft starts only. For a list of actual components used with the ATS48 Enclosed controller, refer to the “Power Fuse Recommendation” (page 41) and “Replacement Parts” (page 47) sections of this bulletin.
- The recommended OCPD ratings in the “Technical Data” section of bulletin S1A37491 applies to open ATS48 soft starts only. For actual components used with ATS48 Enclosed controllers, refer to “Power Fuse Recommendation” on page 41 and “Replacement Parts” on page 47 of this bulletin.
- “Dimensions and Weights” in bulletin S1A37491 applies to open ATS48 soft starts only. For overall enclosure weights, refer to the front elevation drawings supplied with the ATS48 Enclosed controller order.
- “Recommended Wiring Diagrams” in bulletin S1A37491, applies to open ATS48 soft starts, and does not necessarily apply to ATS48 Enclosed controllers. For the exact wiring, refer to the wiring diagram shipped with the enclosed unit.

<sup>1</sup> S1A37491 replaces instruction bulletin 30072-450-61B.

## Terminology

The following terms and abbreviations are used in this bulletin:

- Class 8638 and Class 8639 Altistart 48 Enclosed Soft Start Controllers are called Enclosed 48 controllers.
- MOD for factory modifications
- Altistart 48 Soft Start Controllers are called ATS48 soft starts.

## Standard Features

The Enclosed 48 controller provides a pre-engineered enclosure package with a disconnect means and a starter for soft starting and stopping of standard, three-phase, asynchronous induction motors.

Each Enclosed 48 controller contains:

- Current limiting provisions to achieve short circuit ratings for the unit
- Customer terminal blocks for 120 V control connections
- A disconnect (circuit breaker or fused switch) with an external handle
- A door mounted keypad display for diagnostics and set up
- A shorting contactor which bypasses the soft start when full voltage level is reached upon starting
- Various control and power contactor options may be included in the Enclosed 48 controller. Factory order specific drawings will list all included options.
- Load terminals (T1/T2/T3) for motor connections to the ATS48 soft start.
- Solid state overload protection built in to the ATS48 soft starts.

For information about how to apply and adjust the ATS48 soft start for a particular installation, refer to bulletin S1A37491.

## Before You Begin

### **⚠ DANGER**

#### **HAZARD OF ELECTRIC SHOCK, EXPLOSION, OR ARC FLASH**

- Read and understand this instruction bulletin before installing or operating the Enclosed 48 controller. Installation, adjustment, repair, and maintenance must be performed by qualified personnel.
- The user is responsible for compliance with all international and national electrical code requirements with respect to grounding of all equipment.
- Many parts of this controller, including the printed circuit boards, operate at the line voltage. **DO NOT TOUCH.** Use only electrically insulated tools.
- Some terminals have voltage on them when the disconnect is open.
- Install and close all covers and doors before applying power or starting and stopping the controller.

**Failure to follow these instructions will result in death or serious injury.**

Class 8638<sup>1</sup>

**⚠ DANGER**

**HAZARD OF ELECTRIC SHOCK, EXPLOSION, OR ARC FLASH**

- Apply appropriate personal protective equipment (PPE) and follow safe electrical work practices. See NFPA 70E.
- This equipment must only be installed and serviced by qualified electrical personnel.
- Never operate energized switch with door open.
- Turn off switch before removing or installing fuses or making load side connections.
- Always use a properly rated voltage sensing device at all line and load fuse clips to confirm switch is off.
- Turn off power supplying switch before doing any other work on or inside switch.
- Do not use renewable link fuses in fused switches.

**Failure to follow these instructions will result in death or serious injury.**

<sup>1</sup> This safety message refers to the Enclosed 48 controllers with a fusible disconnect (Class 8638). Unless otherwise specified, all other safety messages in this document refer to all Enclosed 48 controllers.

Class 8639<sup>1</sup>

**⚠ DANGER**

**HAZARD OF ELECTRIC SHOCK, EXPLOSION, OR ARC FLASH**

- Apply appropriate personal protective equipment (PPE) and follow safe electrical work practices. See NFPA 70E.
- This equipment must only be installed and serviced by qualified electrical personnel.
- Turn off all power supplying this equipment before working on or inside the equipment.
- Always use a properly rated voltage sensing device to confirm that power is off.
- Replace all devices, doors, and covers before turning on power to this equipment.

**Failure to follow these instructions will result in death or serious injury.**

**⚠ DANGER**

**UNINTENDED EQUIPMENT OPERATION**

Before turning on the Enclosed 48 controller or upon exiting the configuration menus, ensure that the inputs assigned to the Run command are in a state that will not cause the controller to run. Otherwise, the motor can start immediately.

**Failure to follow these instructions will result in death or serious injury.**

<sup>1</sup> This safety message refers to the Enclosed 48 controllers with a circuit breaker (Class 8639). Unless otherwise specified, all other safety messages in this document refer to all Enclosed 48 controllers.

## **⚠ WARNING**

### **LOSS OF CONTROL**

- The designer of any control scheme must consider the potential failure modes of control paths and, for certain critical control functions, provide a means to achieve a safe state during and after a path failure. Examples of critical control functions are emergency stop and overtravel stop.
- Separate or redundant control paths must be provided for critical control functions.
- System control paths may include communication links. Consideration must be given to the implications of anticipated transmission delays or failures of the link<sup>1</sup>.
- Each implementation of an Enclosed 48 controller must be individually and thoroughly tested for proper operation before being placed into service.

**Failure to follow these instructions can result in death, serious injury, or equipment damage.**

<sup>1</sup> For additional information, refer to NEMA ICS 1.1 (latest edition), "Safety Guidelines for the Application, Installation, and Maintenance of Solid State Control" and to NEMA ICS 7.1 (latest edition), "Safety Standards for Construction and Guide for Selection, Installation and Operation of Adjustable-Speed Drive Systems."

## **⚠ CAUTION**

### **INCOMPATIBLE LINE VOLTAGE**

Before turning on and configuring the Enclosed 48 controller, ensure that the line voltage is compatible with the line voltage range specified on the drive controller nameplate. The drive controller can be damaged if the line voltage is not compatible.

**Failure to follow these instructions can result in injury or equipment damage.**

## **Technical Specifications**

Table 1 on page 10 describes the technical specifications for the Enclosed 48 controllers. For additional specifications of the open style ATS48 soft start, refer to bulletin S1A37491.

Table 1: Technical Specifications

Environment	Degree of protection	<ul style="list-style-type: none"> <li>NEMA Type 1: Indoor use primarily to provide a degree of protection against limited amounts of falling dirt.</li> <li>Type 12: Indoor use primarily to provide a degree of protection against circulating dust, falling dirt, and dripping noncorrosive liquids.</li> <li>Type 3R: Outdoor use primarily to provide a degree of protection against rain, sleet, and damage from ice formation.</li> <li>Enclosures are painted ANSI #49.</li> </ul>
	Conformity to standards	UL listed per UL508; CSA Certified per CSA 22.2 No. 14. Immunity to radioelectrical interference: conforms to IEC 61000-4-3 Level 3.
	Operational test vibration	Conforms to IEC 60068-2-6, 1.5 mm peak from 2 to 13 Hz, 1 gn from 13 to 200 Hz (ATS48 soft starts).
	Seismic qualification	Available as an optional feature (MOD Y10). Provides a qualification label and hardware qualified to seismic rating per ICC ES AC156 for compliance to the seismic provisions of the International Building Code and ASCE 7.
	Transit test to shock	Conforms to the National Safe Transit Association and International Safe Transit Association test for packages weighing 100 lbs and over.
	Ambient air temperature	<ul style="list-style-type: none"> <li>Operation: Ambient conditions in installed area from 0 to 40 °C, 32 to 104 °F (Type 1 and 12); 0 to 50 °C, 32 to 122 °F (Type 3R)</li> <li>Storage: -25 to +70 °C, -13 to 158 °F.</li> </ul>
	Maximum ambient pollution	Conforms to IEC 60664-1, Pollution Degree 3
	Maximum relative humidity	95% without condensation or dripping water conforming to IEC 60068-2-78
	Maximum operating altitude	1000 m (3280 ft.), derate by 2.2% for each additional 100 m (328 ft) up to 3000 m (9842 ft) maximum.
Characteristics	3-phase supply voltage	208 Vac ± 10%; 230 Vac ± 15%; 460 Vac ± 15%; 575 Vac ± 10%
	Control voltage	115 Vac [Control Power Transformer (CPT) included as standard]
	Frequency	50/60 Hz
	Rated current	See Table 7 on page 38.
	Motor power	3 to 600 hp
	Motor voltage	208, 220, 230, 240, 460, 480, 575, 600 V
	Duty cycle	<ul style="list-style-type: none"> <li>Starting at 400% of <math>I_n</math> for 23 s, or 300% of <math>I_n</math> for 46 s, from a cold state</li> <li>Starting at 400% of <math>I_n</math> for 12 s, or 300% of <math>I_n</math> for 23 s, with a load factor of 50% and 10 starts per hour or an equivalent thermal cycling</li> </ul> For additional information, refer to "Application and Protection" in bulletin S1A37491.
Operation	<b>Methods of Starting:</b>	
	Torque ramp	Adjustable from 1 to 60 s by keypad
	Current limitation	Adjustable from 150% to 500% of controller-rated current by keypad
	Booster start-up pulse	Full voltage starting for 5 cycles of 50 to 100% mains voltage, selectable by keypad.
	<b>Methods of Stopping:</b>	
	Freewheel	Coast to stop on stop command
	Torque deceleration ramp	Adjustable from 1 to 60 s by keypad
InTele Braking	Selectable by keypad. Contact Schneider Electric Technical Support for application assistance.	
<b>Status and Diagnostics:</b>	Digital display of motor and controller status, including: <ul style="list-style-type: none"> <li>Ready/Run/Detected Fault</li> <li>Motor Current</li> <li>Motor Torque</li> <li>Motor Thermal State</li> <li>Power Factor</li> </ul>	
Protection	<b>Motor:</b>	
	Thermal overload	With Full Voltage Bypass: A bimetallic or solid state Class 20 (MOD A10) overload relay is integral to the ATS48 soft starts. Without Full Voltage Bypass: A solid state thermal overload is integral to the ATS48 soft start. Overload class is selectable as 10, 20, or 30 via keypad. Range is 50% to 100% of ATS48 soft start rated current.
	Shunt-trip disconnect	Removes all power from the controller cabinet when the ATS48 soft start detects a fault condition.
	Isolation contactor	Removes supply power from the Silicon Control Rectifier (SCR) power circuit and motor when the motor is not running or when the ATS48 soft starts detects a fault condition.
	<b>Controller:</b>	
	Short circuit current ratings	See Table 3 on page 12.
	Overcurrent protection device	An overcurrent protection device (OCPD) provides Type 1 coordination to the short-circuit current withstand ratings. Select fuses for motor protection from Table 9 on page 41.
	Shorting contactor	A standard shorting contactor reduces temperature rise within the enclosure by eliminating the watts loss of the SCRs. Control of the contactor allows all forms of stopping.
Thermal switch	Controllers rated for 17–62 A have one thermal switch to help protect against overheating. Controllers rated 72 A and greater have 2 thermal switches; one controls the fan, the other helps protect against overheating.	

## Controller Nameplate

The nameplate for the Enclosed 48 controller is located on the inside door. It shown identifies the controller Class, Type, and MODs (options). See Figure 1. When identifying or describing the Enclosed 48 controllers, use the data from this nameplate.

Figure 1: Enclosed 48 Controller Nameplate

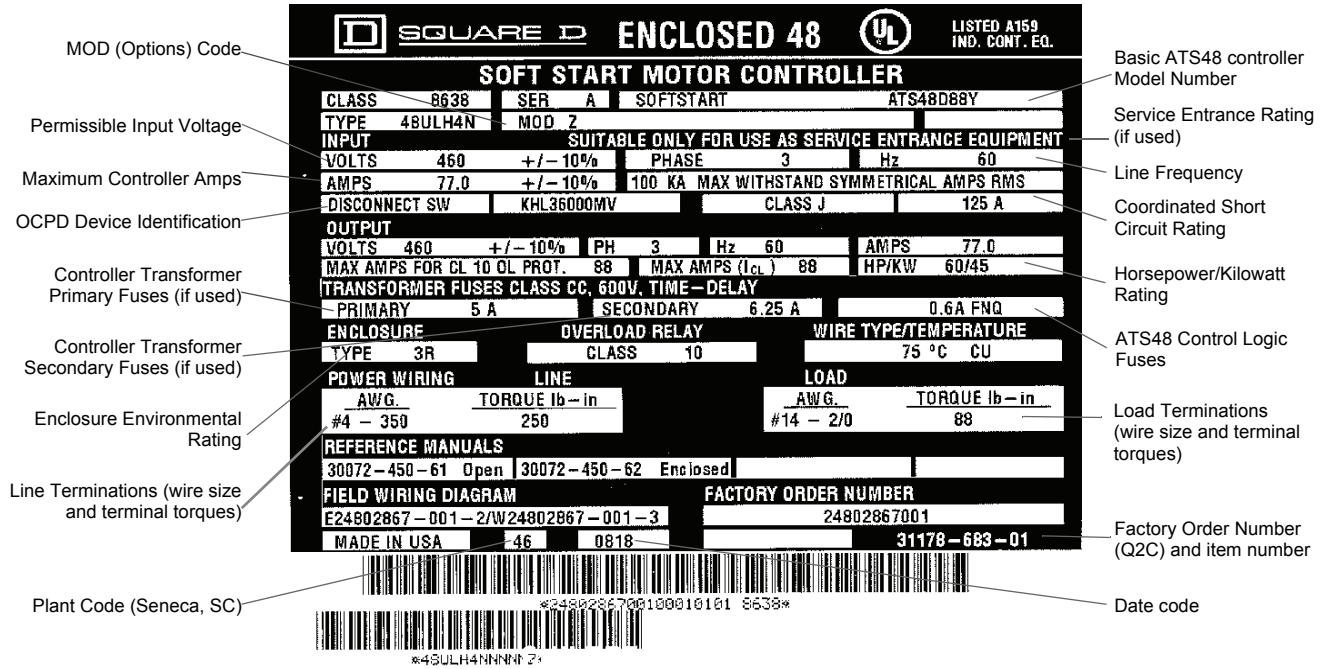

## Catalog Number Identification

Figure 2 identifies each part of the catalog number for Enclosed 48 controllers.

Figure 2: Catalog Number Identification

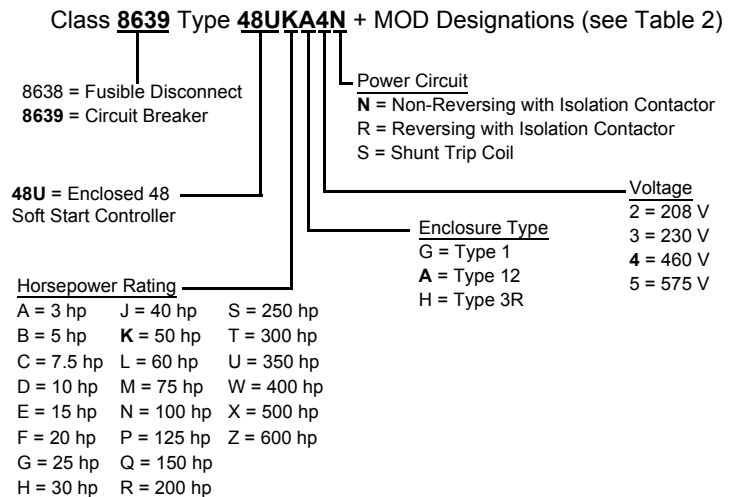

## Form Designations

Table 2 describes the MOD designations for Enclosed 48 controllers.

**Table 2: Factory Modifications (MOD)**

Options	Description	Options	Description
<b>Control</b>		<b>Miscellaneous Options</b>	
A06	Start/Stop pushbuttons	E10	CSA / cUL label(s)
B06	Forward, Stop, and Reverse pushbuttons	F10	Auxiliary contacts for run
C06	Hand-Off-Auto selector switch	G10	Auxiliary contacts for full voltage bypass run
D06	Stop-Run selector switch	H10	Auxiliary contacts for auto mode
E06	Hand-Auto, Start/Stop pushbuttons	J10	Auxiliary contacts for detected fault mode
<b>Pilot Light Clusters</b>		K10	Motor space heater provisions
A07	Run (Red) and Off (green)	L10	ID engraved nameplates
B07	Push-To-Test Run (red) and Off (green)	M10	Spare terminal blocks
C07	Run (Red), Off (green), and Detected Fault (yellow)	P10	Permanent wire markers
D07	Push-To-Test Run (red), Off (green), and Push-To-Reset Fault (yellow)	Q10	ANSI #61 enclosure paint
<b>Meters</b>		R10	MOV/Surge arrestor
A08	Ammeter	S10	Dual motor overloads and branch circuits
B08	Elapsed time meter	T10	Reserved for future
<b>Communications Cards</b>		U10	Omit door mounted keypad
A09	Modbus™	V10	OSHPD Seismic Qualification
C09	Ethernet TCP/IP	W10	NEMA style contactors
D09	Devicenet™	X10	50 °C, 122 °F operation
<b>E09</b>	Ethernet IP	Y10	Seismic qualification (AC156)
<b>Miscellaneous Options</b>		Z10	Service entrance rating
A10	Full voltage bypass (AC3)	710	UL qualified modifications
B10	150 VA additional control capacity	610 <sup>1</sup>	100K circuit breaker rating
C10	Power-Up ON delay (start relay)	810	SPL special features
D10	Emergency Stop pushbutton		

<sup>1</sup> Only available for 208 V, 125–200 hp; 230 V, 150–250 hp; and 460 V, 300–500 hp.

Table 3 describes the coordinated short circuit current ratings for the Enclosed 48 controller.

**Table 3: Short Circuit Current Ratings**

Enclosure Size	Horsepower Rating				8638 Fusible Disconnect AIC	8639 Circuit Breaker AIC
	@ 208 V	@230 V	@ 460 V	@ 575 V		
A–C	3-50	5-60	10-125	15-150	100K	65K
D	60-100	75-125	150-250	200-30	100K	30K
E	125-200	150-250	300-500	350-600	65K	65 or 100K <sup>1</sup>

<sup>1</sup> 100K is only available when option 610 is selected. See Table 2.

## Section 2—Receiving, Handling, and Storage

### **▲ WARNING**

#### **DAMAGED CONTROLLER EQUIPMENT**

Do not operate any Enclosed 48 controller that appears damaged.

**Failure to follow these instructions can result in injury or equipment damage.**

### Receiving and Preliminary Inspection

Thoroughly inspect the Enclosed 48 controller before it is stored or installed. Upon receipt:

1. Remove the controller from its packaging and visually inspect the exterior for shipping damage.
2. Ensure that the Class, Type, and MOD specified on the controller nameplate (see page 11) agree with the packaging slip and corresponding purchase order.
3. If you find any shipping damage, notify the carrier and your sales representative.
4. Enclosed 48 controllers are shipped on a pallet on their back or in an upright position. To avoid damage, do not stack units on top of each other. If you plan to store the controller after receipt, replace it in its original packaging material and store it in an environment whose ambient air temperature is within the range specified in Table 1 on page 10. Store the controller in its original packaging until it is at the final installation site.

### Before Installation

Before installing the Enclosed 48 controller:

1. Move the operating handle assembly to the Off position and open the Enclosed 48 controller door.
2. Visually verify that all internal mounting and terminal connection hardware is properly seated, securely fastened, and undamaged.
3. Visually verify that the internal plugs and wiring connections are tight. Inspect all connections for damage.
4. Verify that all relays and fuses are installed and fully seated.
5. Close and secure the Enclosed 48 controller door by fully tightening the thumbscrews.

### **NOTICE**

#### **STACKING DURING STORAGE OR SHIPPING**

- Do not stack Enclosed 48 controllers on top of each other.
- Do not place any material on the top of the Enclosed 48 controller.

**Failure to follow these instructions can result in equipment damage.**

## Handling the Controller

Figure 3: Hoisting Enclosed 48 Controllers

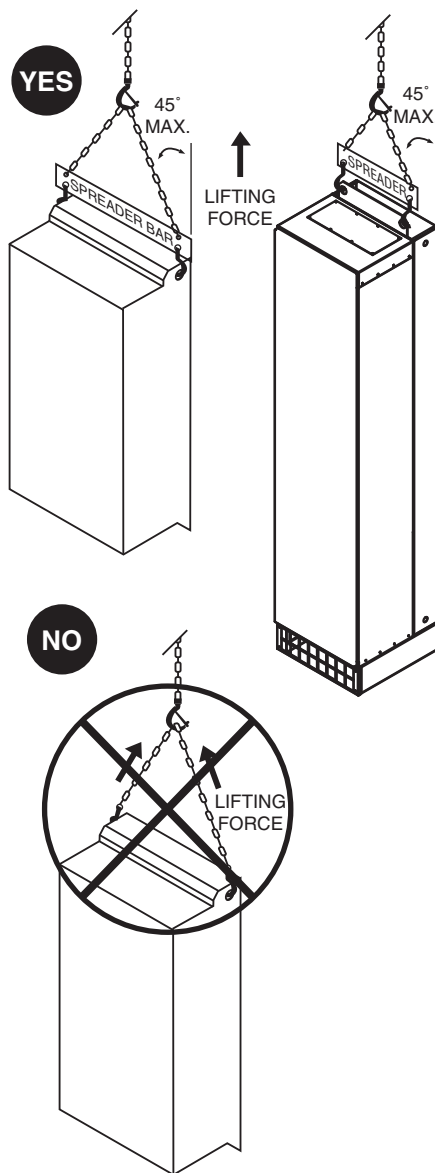

### ⚠ WARNING

#### LIFTING HEAVY EQUIPMENT

Keep the area below any equipment being lifted clear of all personnel and property. Use the lifting method shown in Figure 3.

**Failure to follow these instructions can result in death, serious injury, or equipment damage.**

Handle the Enclosed 48 controller carefully to avoid damage to the internal components, frame, or exterior. When handling the controller, balance it carefully to keep it from tipping. After removing the packaging materials, the controller requires some type of mechanical lifting.

When handling the Enclosed 48 controllers:

- Always work with another person. The weight, size, and shape of the controller are such that two people are required to handle it.
- Use gloves.
- Attach a spreader bar to the two top lifting holes on the controller back panel or lifting bracket (see Figures 4–14 for location of lifting holes) and hoist the controller with chains or straps. See Figure 3 for the proper hoisting method.
- Raise the controller from a horizontal position (that is, with the back of the controller resting on a pallet).
- Before removing banding or lag bolts (if used), attach the spreader bar with chains or straps (hoisting mechanism) to maintain control or tipping.
- Place the controller in an upright position.

**NOTE:** Wall mounted enclosures will not sit upright without support. The bottom of the wall mounting Enclosed 48 controller is on an angle.

### ⚠ WARNING

#### IMPROPER MOUNTING

Before removing the lifting mechanism:

- Ensure that all hardware is of sufficient size and type for the controller weight.
- Secure and tighten all hardware.

**Failure to follow these instructions can result in death, serious injury, or equipment damage.**

## Section 3—Installation

### **⚠ DANGER**

#### **HAZARD OF ELECTRIC SHOCK, EXPLOSION, OR ARC FLASH**

Read and understand the precautions in “Before You Begin” starting on page 6 before performing the procedures in this section.

**Failure to follow these instructions will result in death or serious injury.**

## Precautions

Read, understand, and follow all precautions described in this instruction bulletin and in the reference documents listed on page 5 before attempting to install, service, or maintain the Enclosed 48 controller.

Follow these precautions when installing Enclosed 48 controllers:

- The Enclosed 48 controller can be installed in a Pollution Degree 3 environment, as defined in NEMA ICS1-111A and IEC 60664-1. Ensure that the expected environment is compatible with this rating.
- When attaching wall mounted and free standing controllers, use fasteners rated for the weight of the apparatus, the expected shock and vibration of the installation, and the expected environment.
- During installation and operation, maintain the ventilation clearances specified on the factory supplied outline dimensional drawings or in Figures 8–18. Provide sufficient cooling for the heat load.
- Do not mount the controller in direct sunlight or on hot surfaces (Type 1 and 12 only). Mount it on a solid, flat surface only. *When drilling for conduit entry, take care to prevent metal chips from falling on parts and electronic printed wiring boards.*

## Seismic Qualification Mounting Criteria

Seismic qualification (MOD Y10) harmonizes the following standards in compliance with ICC ES AC156 acceptance criteria test protocol with an importance factor of 1.5:

- IBC (International Building Code)
- NFPA 5000 (Building Code – National Fire Protection Agency)
- NBCC (National Building Code of Canada)
- 1997 UBC (Uniform Building Code)
- 1999 NBC (BOCA National Building Code)
- 1999 SBC (Standard Building Code)
- ASCE 7 (American Society of Civil Engineers)

For seismic rating installation compliance, follow the instructions in the labels attached to the controller (see Figures 4–7 on 16) for anchorage, lateral, and mounting guidelines using **SAE Grade 5 hardware bolts and washers**. These guidelines apply for both floor and wall mounted Type 1, 12K, and 3R enclosures.

Figure 4: Certification Label

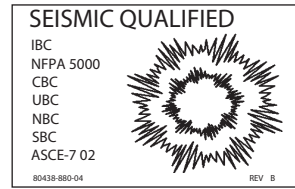

Figure 5: Floor Mounting

**SEISMIC ANCHORAGE REQUIREMENTS**

To maintain Seismic Qualification each individual section must be anchored to floor at all mounting locations shown in Instruction Manual.

For seismic hazard areas with an  $S_s$  acceleration value in excess of 2.67 g (New Madrid Seismic Hazard Area) or displacement at the top of the enclosure cannot be tolerated, the enclosure must be laterally braced at the top of the section and connected to the building load bearing structural system. Refer to the current IBC or NFPA 5000 for location specific values of  $S_s$ .

Use 1/2" grade 5 bolts and the appropriate washers. In order to develop full strength of the anchor, torque bolts to the value specified by the anchor manufacturer.

Refer to Instruction Manual 30072-450-62 for installation instructions.

80438-908-02 Rev. -

Figure 6: Floor Mounting (Type 1 and 12 only)

● Seismic Anchorage Location

**Seismic Anchorage Requirements**

For seismic hazard areas with an  $S_s$  acceleration value in excess of 2.67 g (New Madrid Seismic Hazard Area) or displacement at the top of the enclosure cannot be tolerated, the enclosure must be laterally braced at the top of the section and connected to the building load bearing structural system. Refer to the current IBC or NFPA 5000 for location specific values of  $S_s$ .

Remove lifting bracket after equipment has been installed, and attach lateral brace (supplied by others), re-using bolt and lock washer or user supplied hardware.

Equipment must also be anchored at the base (as shown on the instruction label located on the inside of the door).

Refer to Bulletin number 30072-450-62 for installation instructions.

80438-880-14 REV -

Figure 7: Wall Mounting

**SEISMIC ANCHORAGE REQUIREMENTS**

■ Seismic Anchorage Location

To maintain Seismic Qualification each individual enclosure must be anchored to wall at all five mounting locations shown to the left. Use 3/8" grade 5 bolts and the appropriate flat washers. In order to develop full strength of the anchor, torque bolts to the value specified by the anchor manufacturer. Refer to Instruction Manual 30072-450-62 for installation instructions.

80438-908-01 box REV B

# Mounting Dimensions and Weights

Figures 8–18 show the dimensions of the various wall mounted and floor mounted enclosure types. Table 4 on page 30 lists the weights and estimated watts loss.

**Figure 8: Size A Enclosure, Wall Mounted, Type 1, 12, and 3R: 3–5 hp @ 208 V, 5–15 hp @ 230 V, 10–30 hp @ 480 V, and 15–40 hp @ 575 V**

Dimensions: in. [mm]

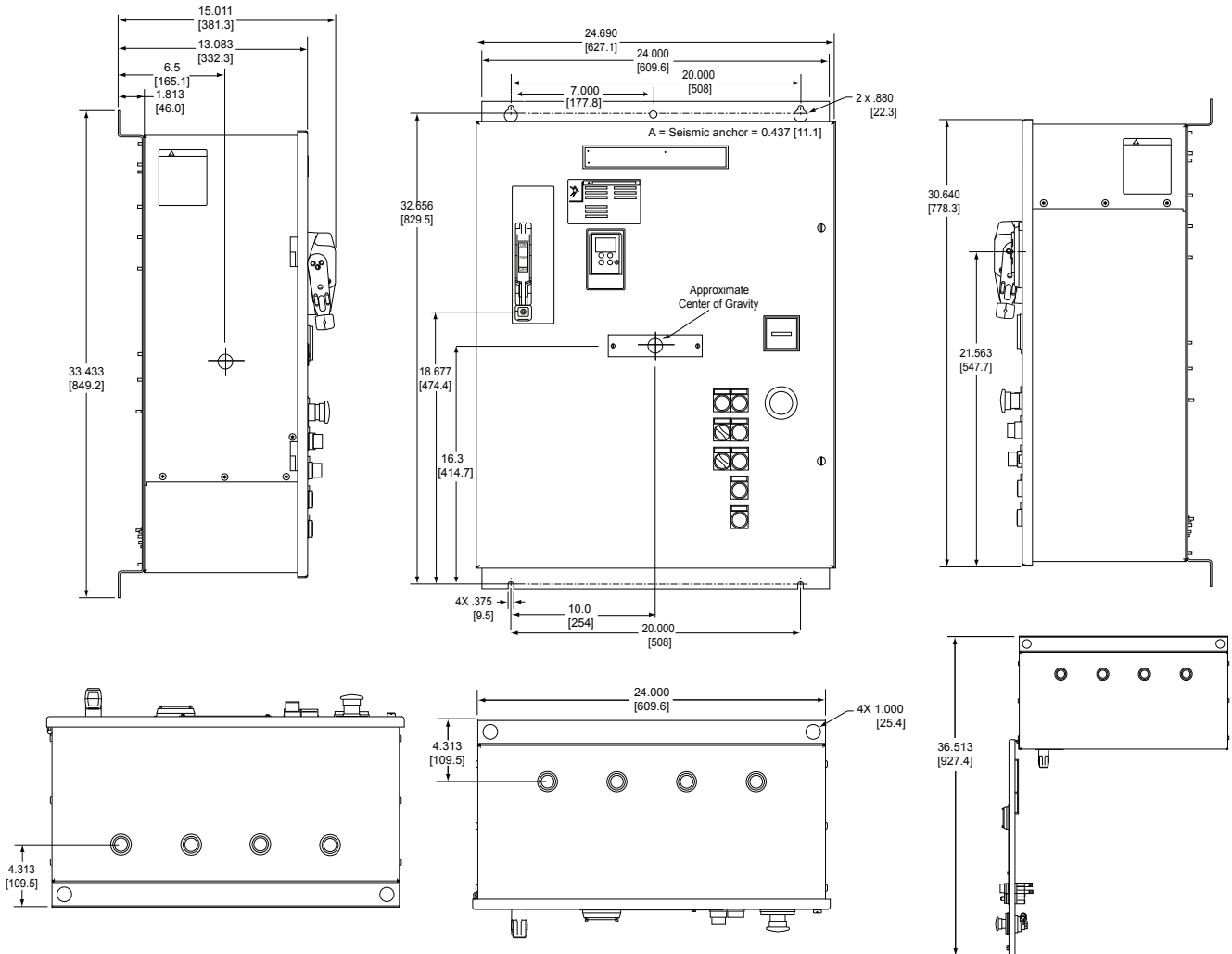

**Figure 9: Size B Enclosure, Wall Mounted, Type 1, 12, and 3R: 15–30 hp @ 208 V, 20–40 hp @ 230 V, 40–75 hp @ 480 V, and 50–100 hp @ 575 V<sup>1</sup>**

Dimensions: in. [mm]

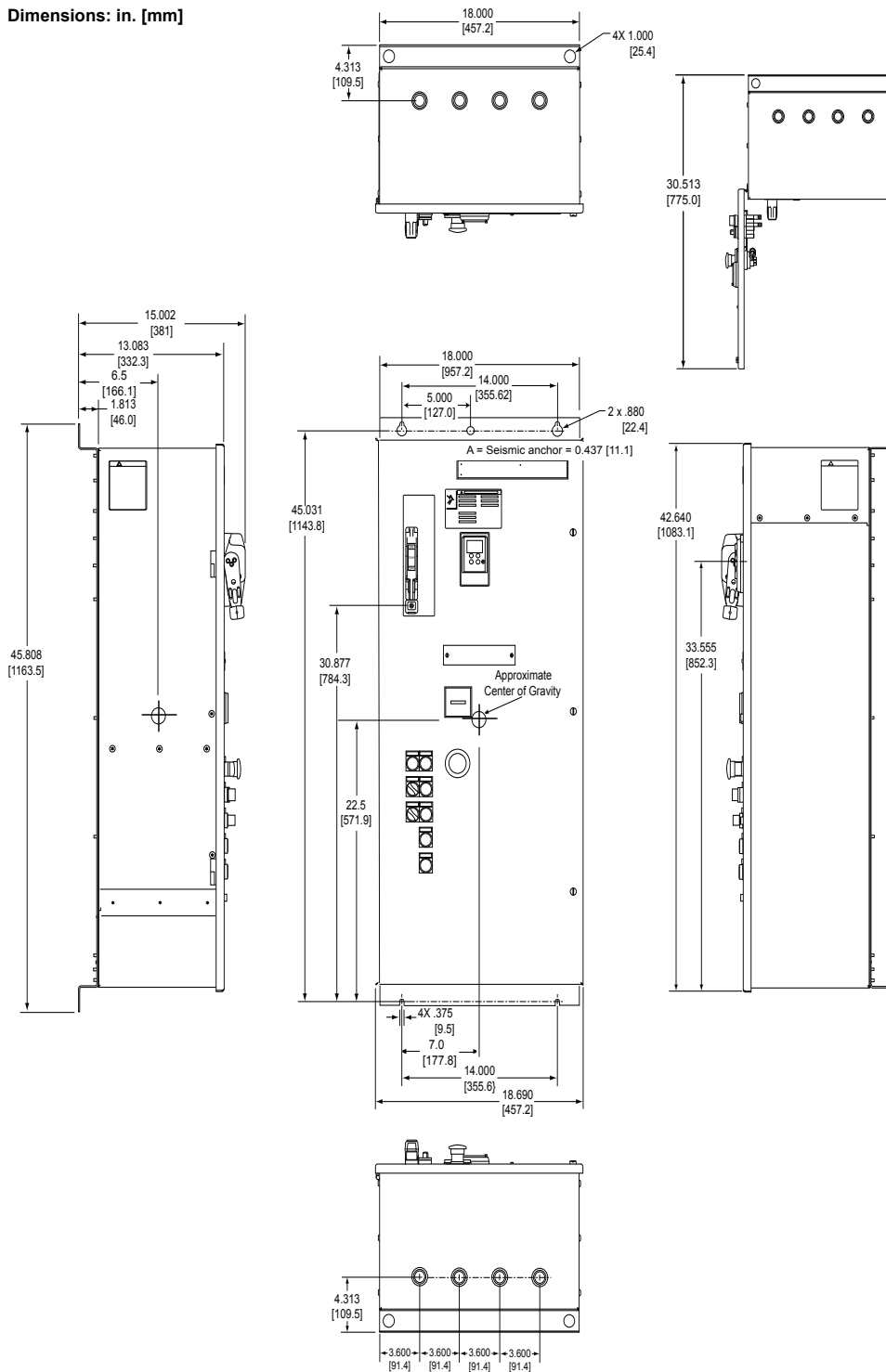

<sup>1</sup> These horsepower and voltage combinations with a shunt-trip circuit are available in the Size A enclosure. See Figure 8.

Figure 10: Size C Enclosure, Wall Mounted, Type 1, 12, and 3R: 40–50 hp @ 208 V, 50–60 hp @ 230 V, 100–125 hp @ 480 V, and 125–150 hp @ 575 V

Dimensions: in. [mm]

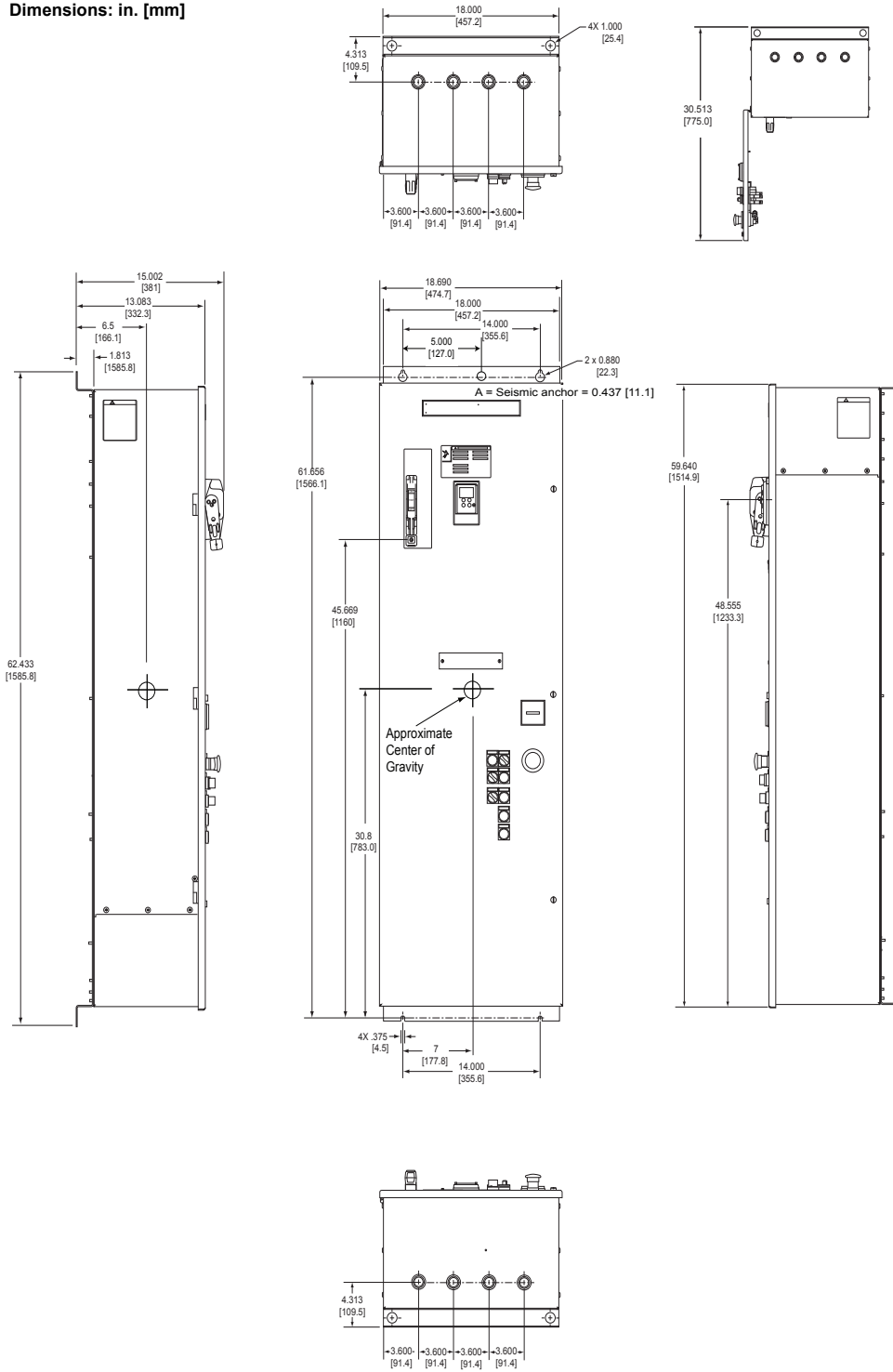

**Figure 11: Size D Enclosure, Floor Mounted, Type 1 and 12, 20 inches wide, 8639 Power Circuit S (Shunt Trip) only:  
 60–100 hp @ 208 V, 75–125 hp @ 230 V, 150–250 hp @ 480 V, and 200–300 hp @ 575 V**

Dimensions: in. [mm]

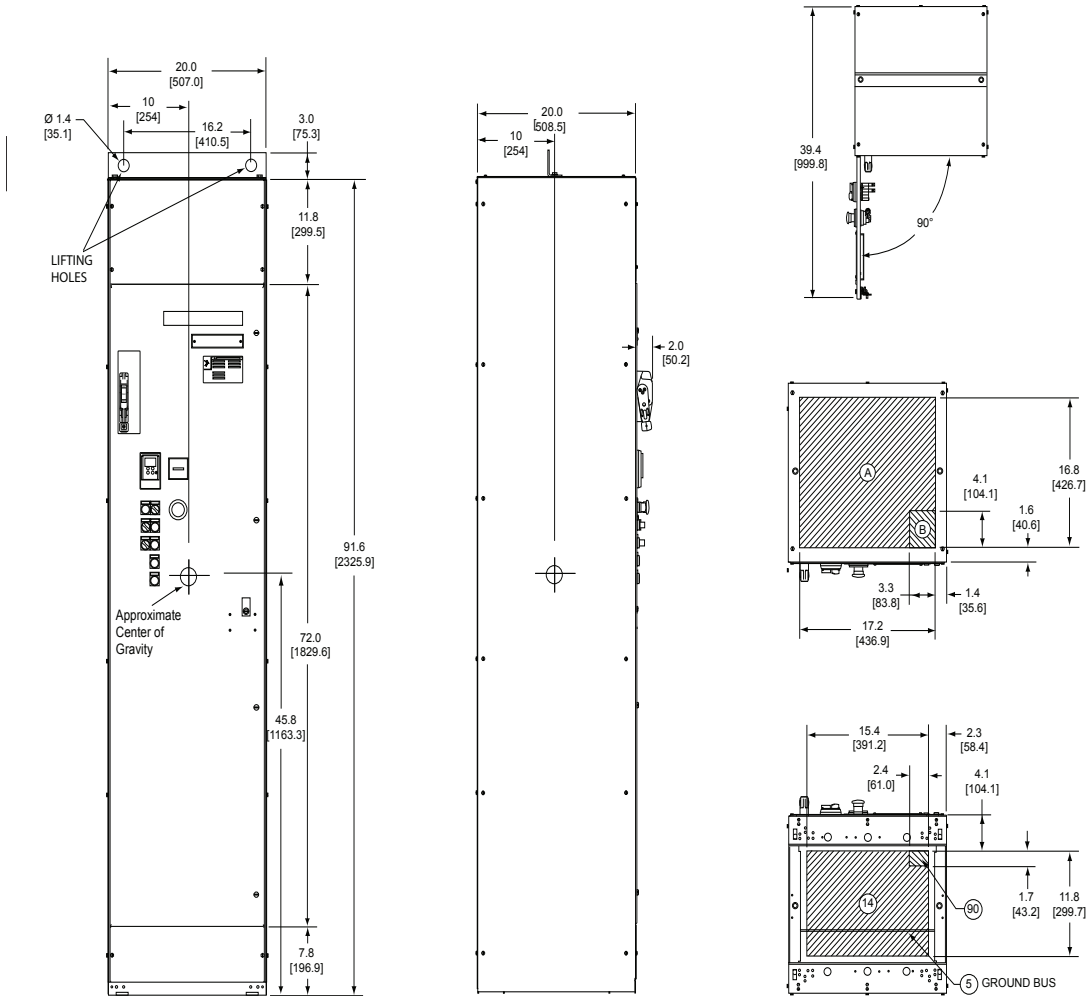

NOTES:

1. Circled numbers indicate depth in inches.
2. A = Standard Anchors, B = Seismic Anchors 0.88 [22.4]

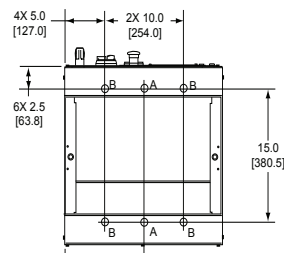

**Figure 12: Size D Enclosure, Floor Mounted, Type 3R, 20 inches wide, 8639 Power Circuit S (Shunt Trip) only:  
 60–100 hp @ 208 V, 75–125 hp @ 230 V, 150–250 hp @ 480 V, and 200–300 hp @ 575 V**

Dimensions: in. [mm]

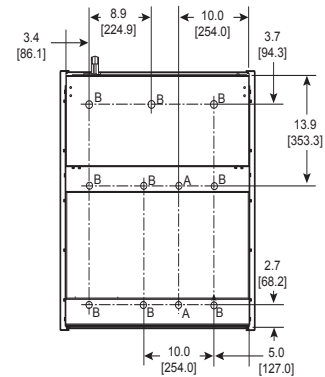
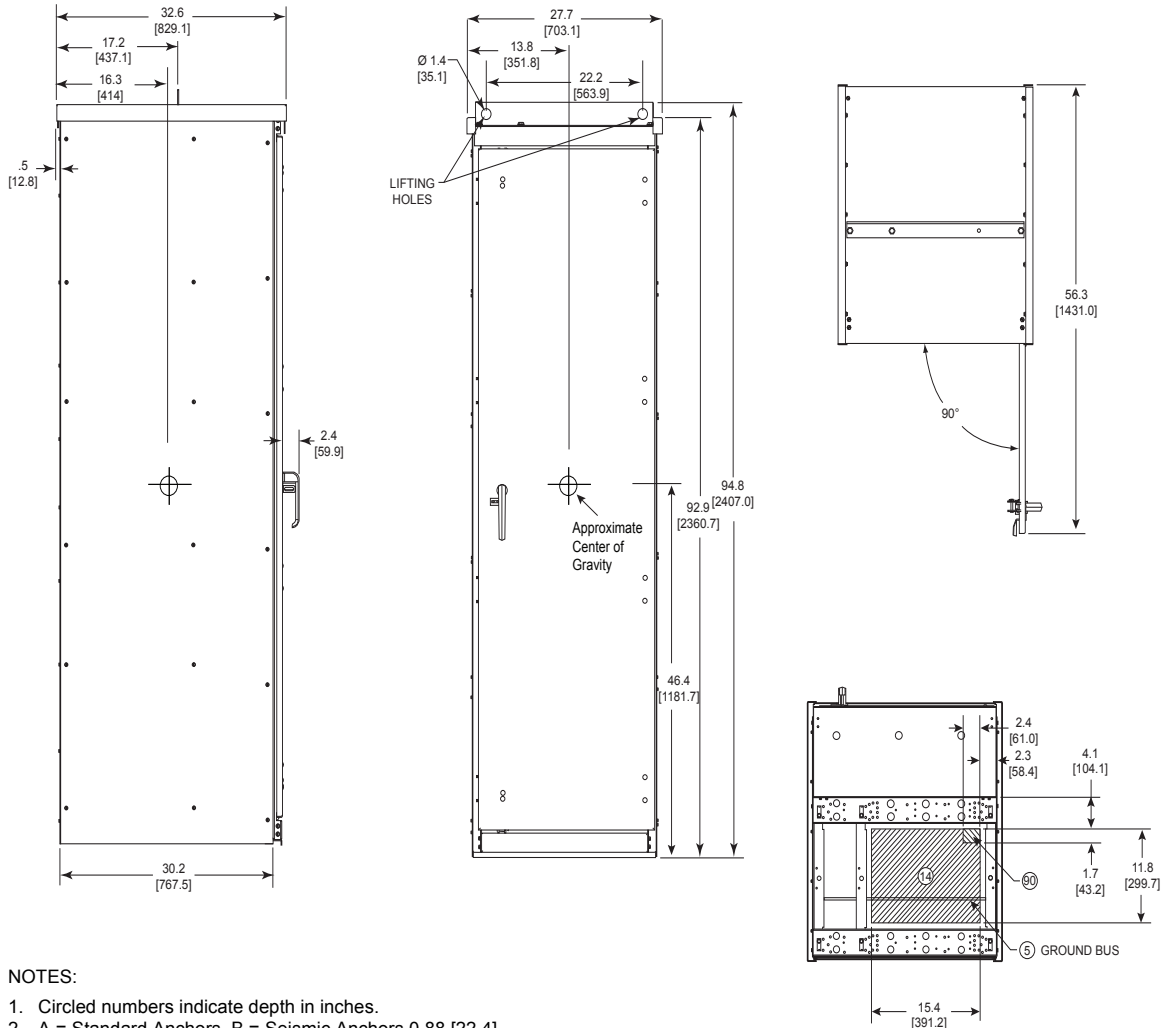

**Figure 13: Size D Enclosure, Floor Mounted, Type 1 and 12, 30 inches wide, 8639 Power Circuit N (Isolation Contactor) or R (Reversing): 60–100 hp @208 V, 75–125 hp @ 230 V, 150–250 hp @ 480 V, and 200–300 hp @ 575 V**

Dimensions: in. [mm]

NOTES:

1. Circled numbers indicate depth in inches.
2. A = Standard Anchors, B = Seismic Anchors 0.88 [22.4]

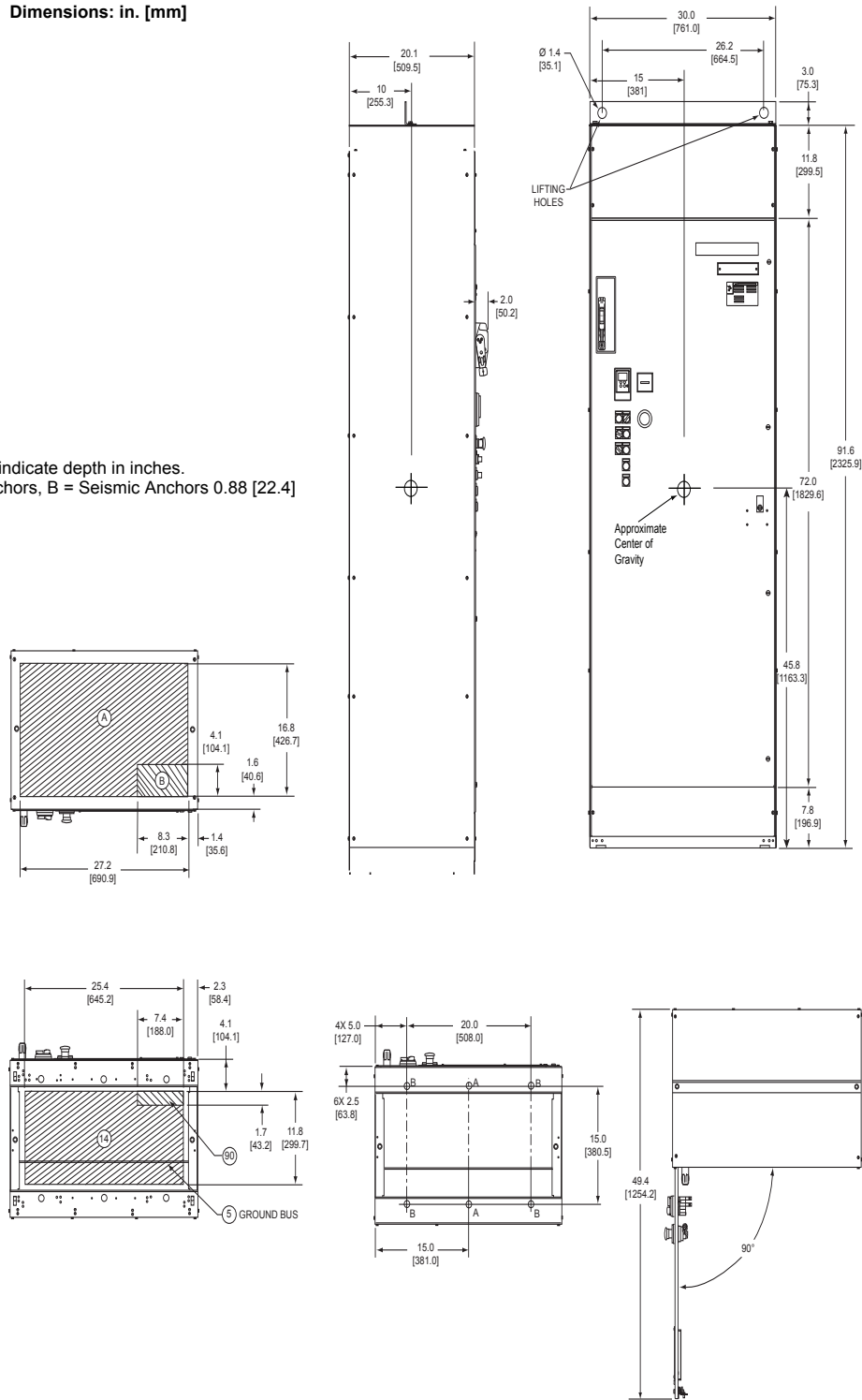
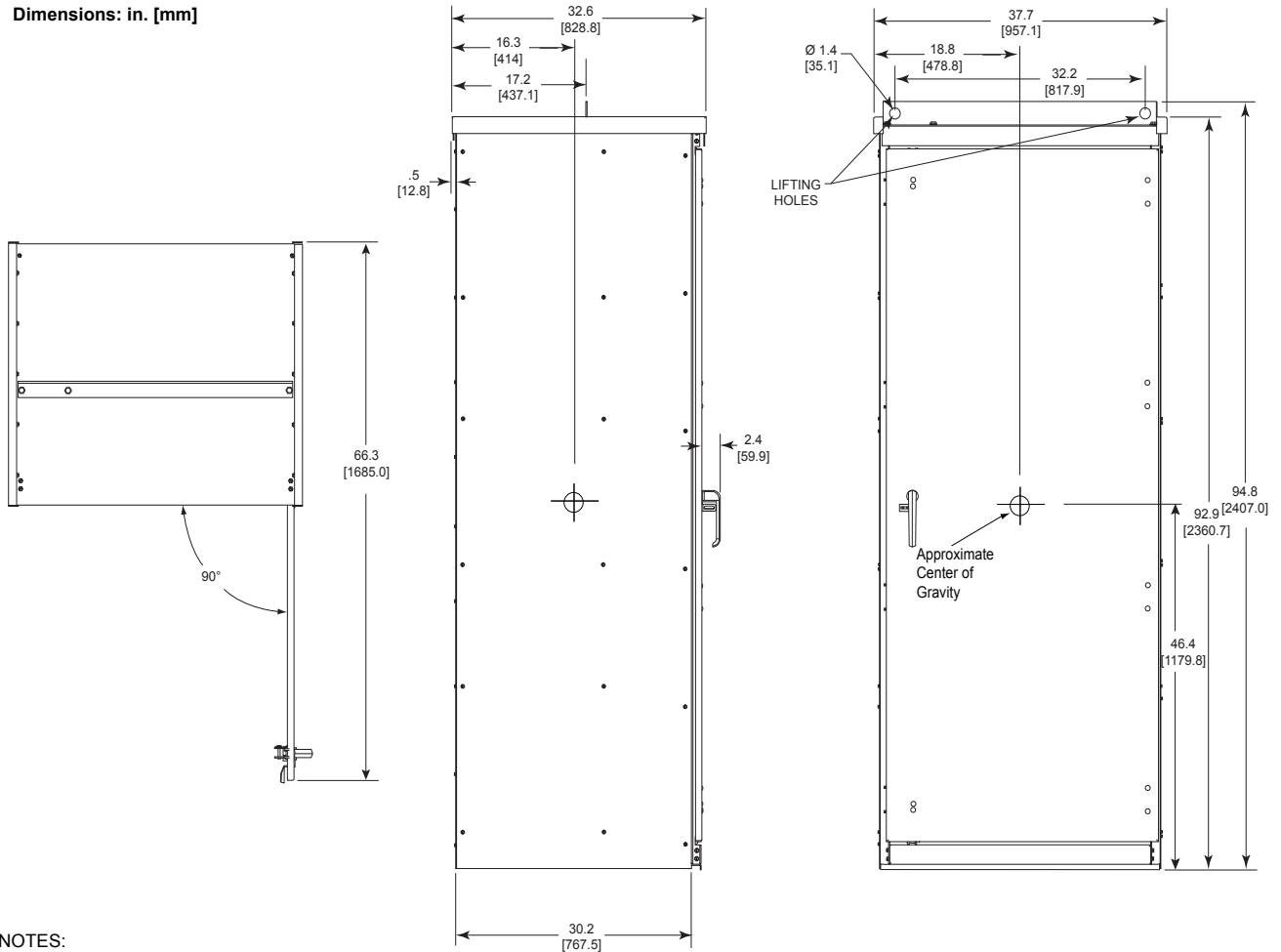

Figure 14: Size D Enclosure, Floor Mounted, Type 3R, 30 inches wide, 8639 Power Circuit N (Isolation Contactor) or R (Reversing): 60–100 hp @ 208 V, 75–125 hp @ 230 V, 150–250 hp @ 480 V, and 200–300 hp @ 575 V

Dimensions: in. [mm]



NOTES:

1. Circled numbers indicate depth in inches.
2. A = Standard Anchors, B = Seismic Anchors 0.88 [22.4]

**Figure 15: Size E Enclosure, Floor Mounted, Type 1 and 12, 35 inches wide, 8638 and 8639 Power Circuit N (Isolation Contactor) or S (Shunt Trip): 125–200 hp @ 208 V, 150–250 hp @ 230 V, 300–500 hp @ 480 V, and 350–600 hp @ 575 V**

Dimensions: in. [mm]

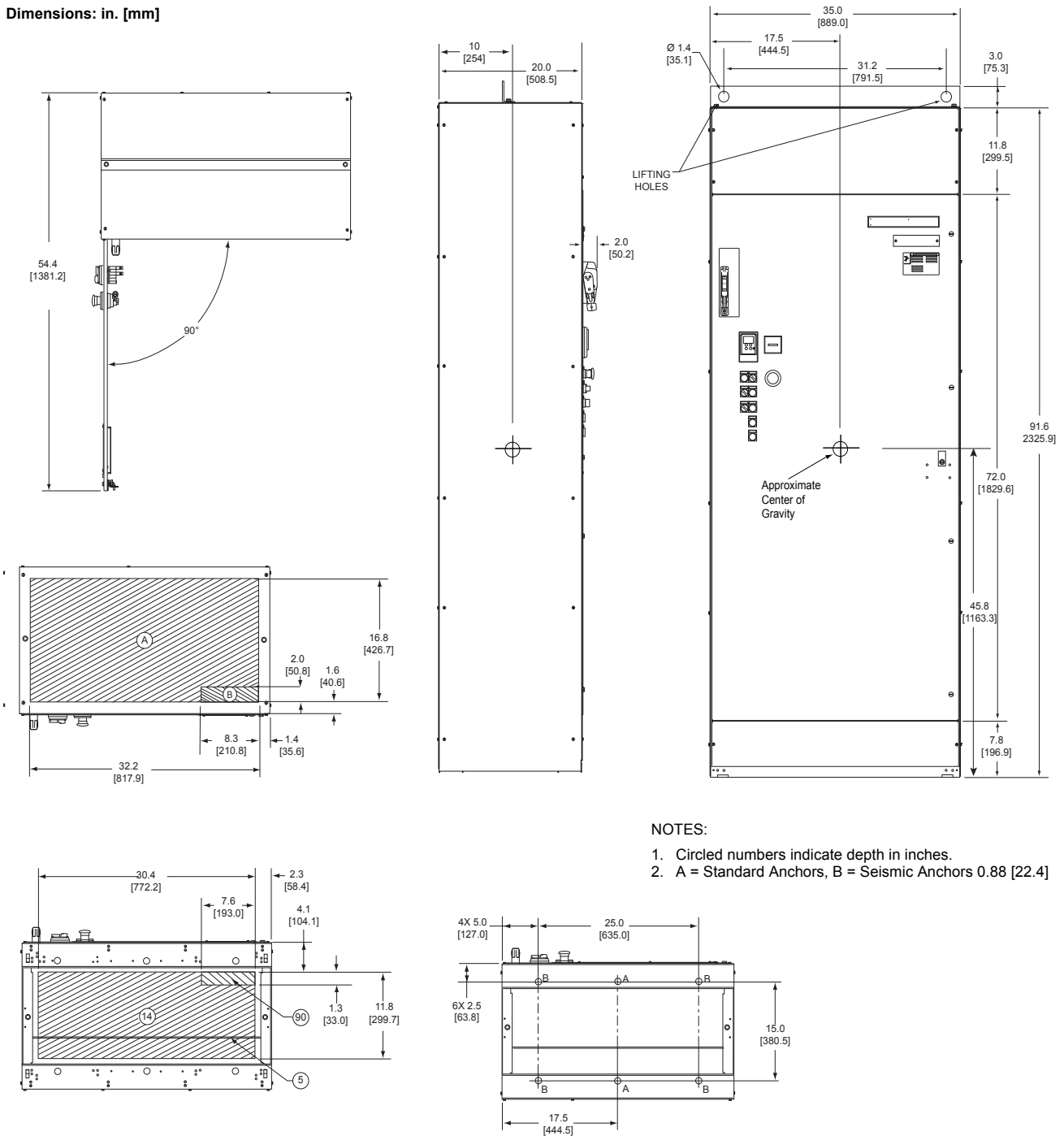

NOTES:

1. Circled numbers indicate depth in inches.
2. A = Standard Anchors, B = Seismic Anchors 0.88 [22.4]

**Figure 16: Size E Enclosure Outline, Floor Mounted, Type 3R, 55 in. wide, 8638 and 8339 Power Circuit R (Reversing):  
 125–200 hp @ 208 V, 150–250 hp @ 230 V, 300–500 hp @ 480 V, and 350–600 hp @ 575 V**

Dimensions: in. [mm]

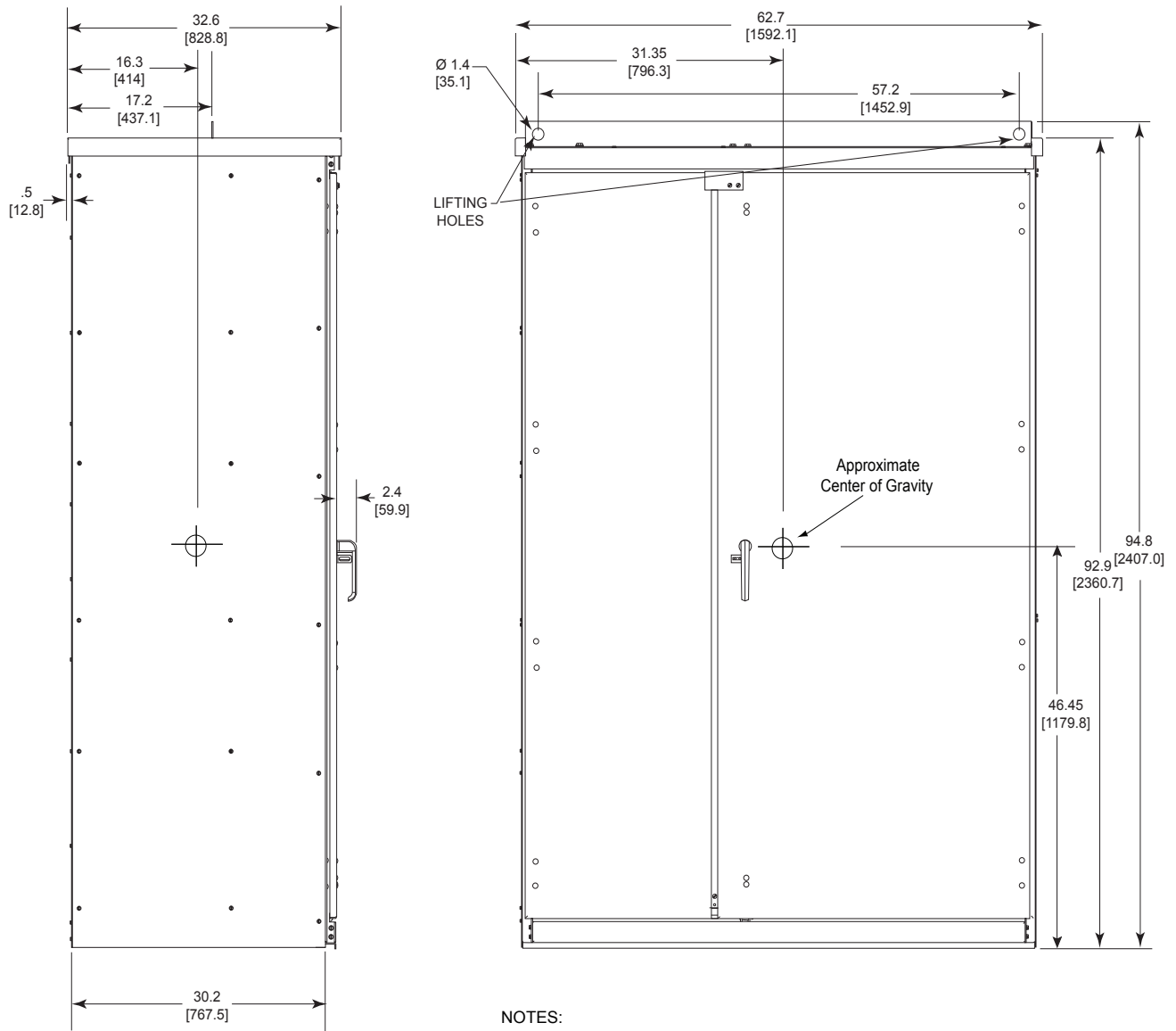

NOTES:

1. Circled numbers indicate depth in inches.
2. A = Standard Anchors, B = Seismic Anchors 0.88 [22.4]

Continued from page 25

Dimensions: in. [mm]

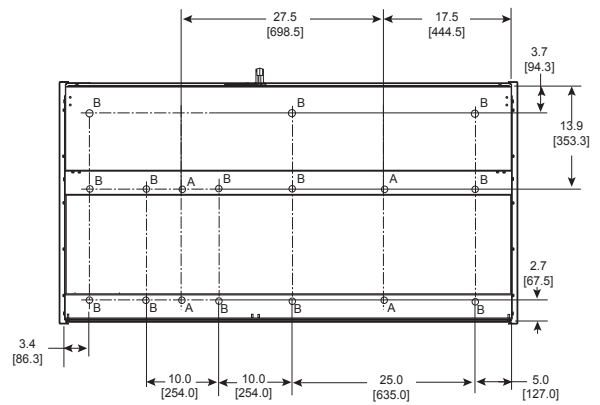
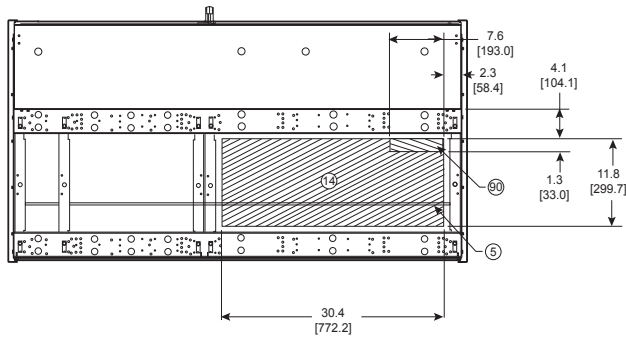
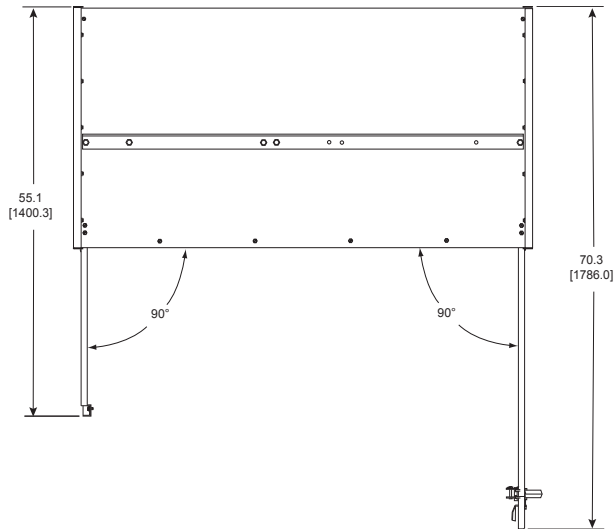

**Figure 17: Size E Enclosure, Floor Mounted, Type 1 and 12, 55 inches wide, 8638 and 8339 Power Circuit R (Reversing): 125–200 hp @ 208 V, 150–250 hp @ 230 V, 300–500 hp @ 480 V, and 350–600 hp @ 575 V**

Dimensions: in. [mm]

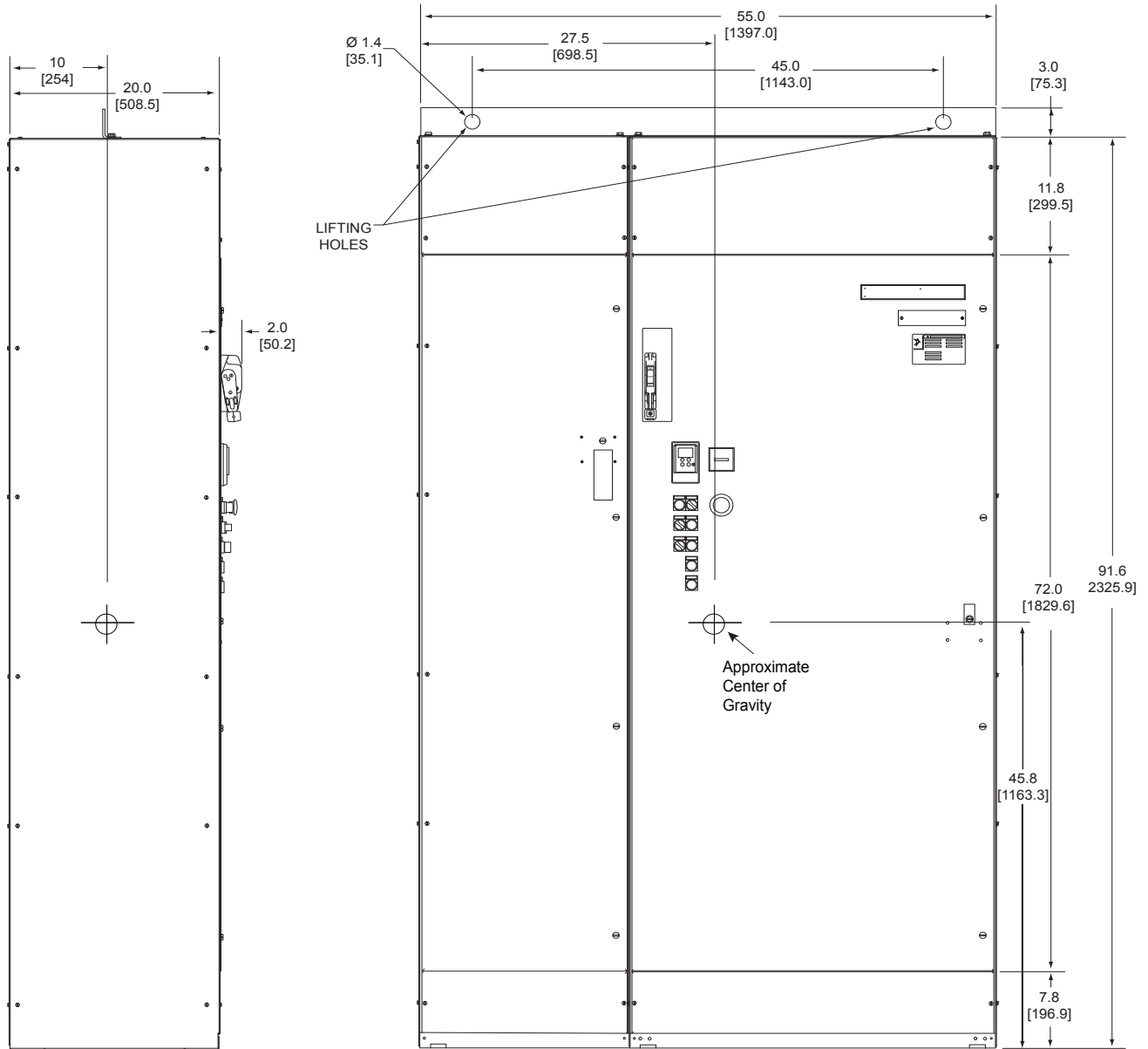

Continued on next page

Continued from page 27

Dimensions: in. [mm]

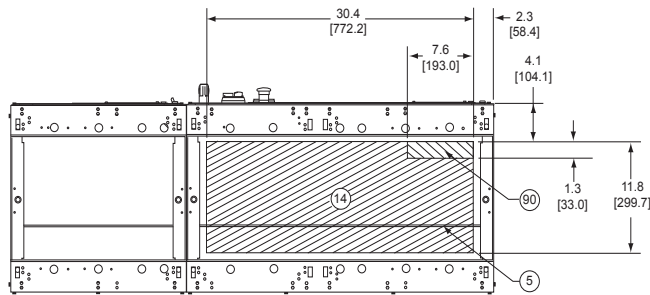
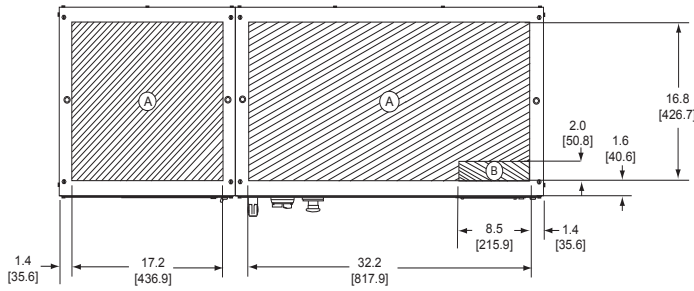

NOTES:

1. Circled numbers indicate depth in inches.
2. A = Standard Anchors, B = Seismic Anchors 0.88 [22.4]

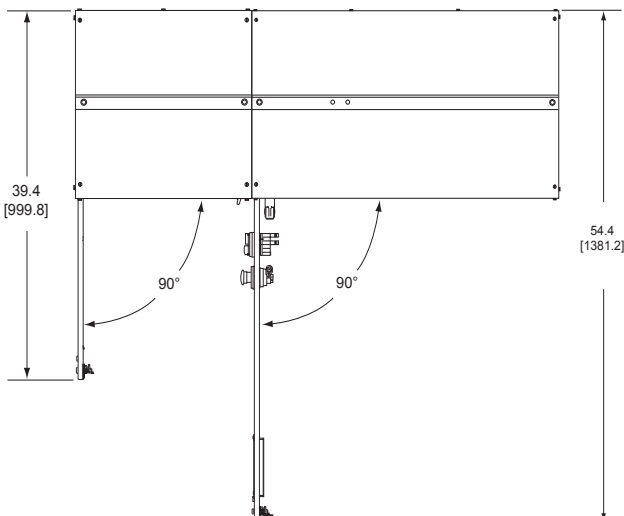
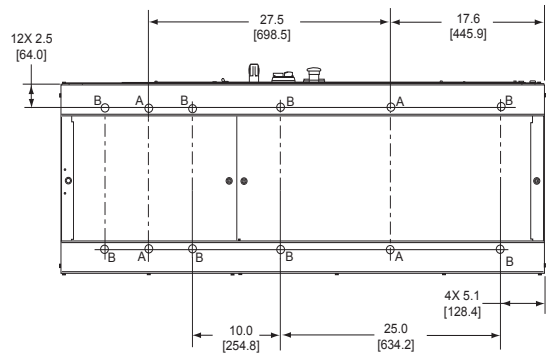

**Figure 18: Size E Enclosure, Floor Mounted, Type 3R, 35 inches wide, 8638 and 8639 Power Circuit N (Isolation Contactor) or S (Shunt Trip): 125–200 hp @ 208 V, 150–250 hp @ 230 V, 300–500 hp @ 480 V, and 350–600 hp @ 575 V**

Dimensions: in. [mm]

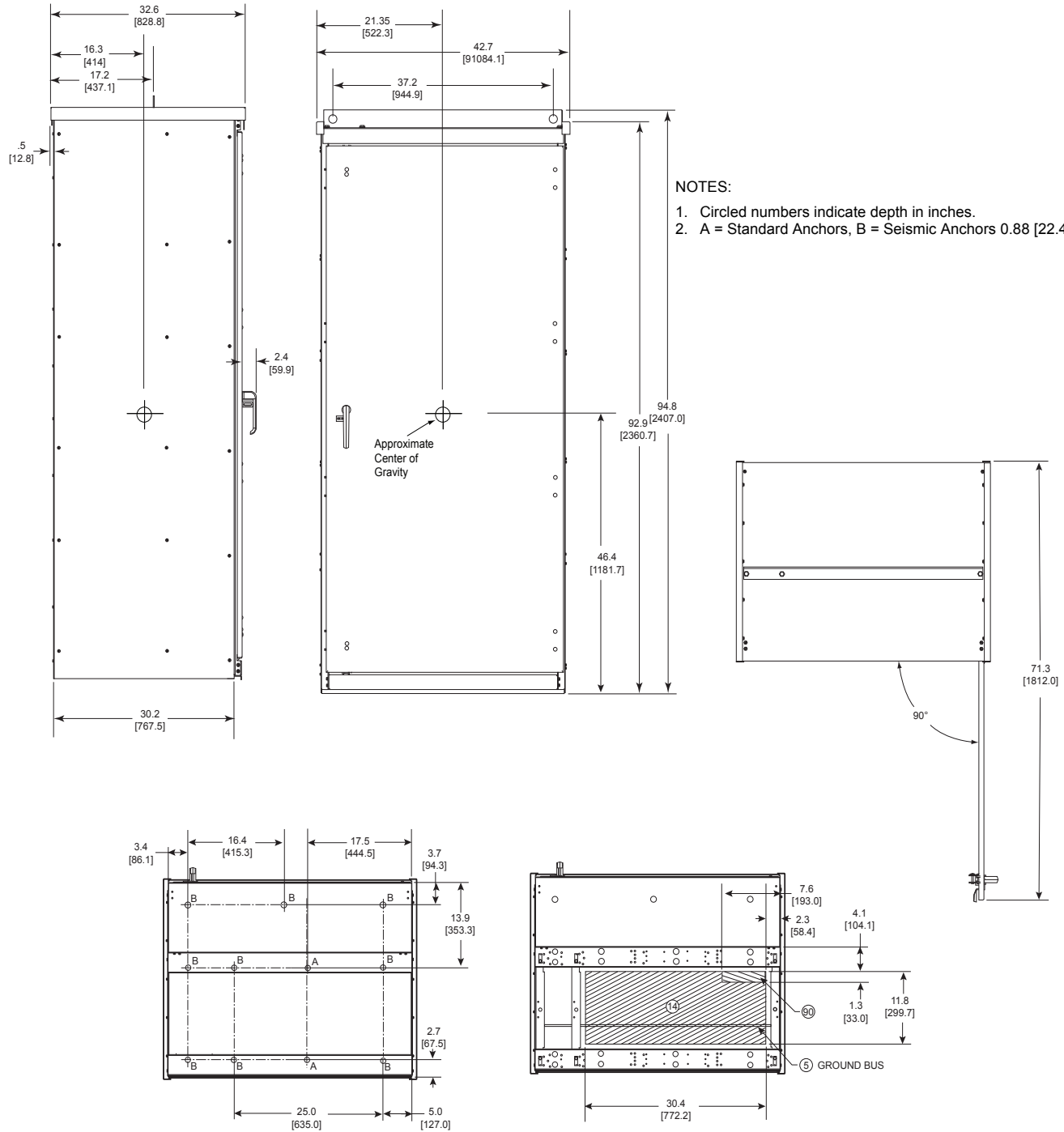

Table 4 lists the weights for the devices illustrated in Figures 8 through 18. It also provides the estimated watts loss for the Enclosed 48 controllers.

**Table 4: Weights and Estimated Watts Loss**

Class 8638 and 8639 Enclosed 48 Controllers Horsepower Ratings						Estimated Watts Loss <sup>1</sup>	Weights (lb) <sup>2</sup>								
Size	ATS48_YU <sup>3</sup> Device	208 V	230 V	460 V	575 V		Power Circuits								
							Type 1			Type 12			Type 3R		
						N	R	S	N	R	S	N	R	S	
A	D17	3	5	10	15	285 W Start 158 W Run	110			110			110		
A	D22	5	7.5	15	20										
A	D32	7.5	10	20	25										
A	D38	10	–	25	30										
A	D47	–	15	30	40										
B	D62	15	20	40	50	529 W Start 258 W Run	125			125			125		
B	D75	20	25	50	60										
B	D88	25	30	60	75										
B	C11	30	40	75	100										
C	C14	40	50	100	125	529 W Start 258 W Run	200			200			200		
C	C17	50	60	125	150										
D	C21	60	75	150	200	1264 W Start 538 W Run	500	500	400	500	500	400	525	525	425
D	C25	75	100	200	250										
D	C32	100	125	250	300										
E	C41	125	150	300	350	2482 W Start 1004 W Run	750	1000	750	750	1000	750	800	1050	800
E	C48	150	–	350	400										
E	C59	–	200	400	500										
E	C66	200	250	500	600										

<sup>1</sup> Watts loss conditions identified in Start (ATS48 soft start mode) during installation /deceleration ramp. Run (shorting contactor mode) during operating conditions.  
<sup>2</sup> Power Circuit **N** is non-reversing with an isolation contactor. Power Circuit **R** is reversing with an isolation contactor. Power Circuit **S** is a Shunt Trip Coil with a molded case.  
<sup>3</sup> The underscore ( \_ ) represents the variable part of the catalog number.

## Wiring

### **⚠ DANGER**

#### **HAZARD OF ELECTRIC SHOCK, EXPLOSION, OR ARC FLASH**

Turn off all power (main and remote) before installing the equipment. Refer to “Before You Begin” starting on page 6 before performing the procedures in this section.

**Failure to follow these instructions will result in death or serious injury.**

### **⚠ CAUTION**

#### **IMPROPER WIRING HAZARDS**

Follow the wiring practices described in this document in addition to those already required by the National Electrical Code® and local codes.

**Failure to follow these instructions can result in injury or equipment damage.**

## Grounding

Ground the Enclosed 48 controller according to the National Electrical Code and all local codes. To ground the drive controller:

- Connect a copper wire from the ground bar terminal to the power system ground.
- Verify that the resistance to ground is 1  $\Omega$  or less. Improper grounding causes intermittent and unreliable operation.

### **⚠ DANGER**

#### **HAZARD OF ELECTRIC SHOCK**

- Ground equipment using the provided ground connection point. The Enclosed 48 controller panel must be properly grounded before power is applied.
- Do not use metallic conduit as a ground conductor.

**Failure to follow these instructions will result in death or serious injury.**

Ground multiple Enclosed 48 controllers as shown in Figure 19. Use one grounding conductor per device. Do not loop ground conductors or install them in series.

Figure 19: Grounding Multiple Enclosed 48 Controllers

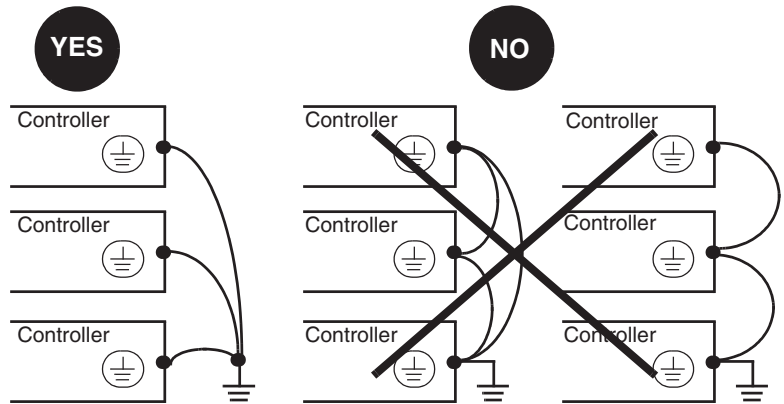

## Control Wiring

The customer terminal block pulls apart to facilitate control wiring. To access the control terminals, remove the top portion of the terminal block from the base by grasping it and pulling up. See Figure 20. Connect the control wiring to the top portion of the terminal block.

Each terminal is rated for one 16–12 AWG (1.3–3.3 mm<sup>2</sup>) wire or two 16 AWG (1.3 mm<sup>2</sup>) wires. Torque the terminal screws to 5 lb-in (0.6 N•m). The customer terminal block is designated TB1 on the wiring diagrams shipped with the Enclosed 48 controller.

**NOTE:** Depending on the power and control options ordered, several analog or digital inputs and outputs will be available at the control terminal blocks on the Altistart 48 soft start. For I/O availability, refer to the elementary diagram supplied with the Enclosed 48 controller. For I/O specifications and adjustments, refer to bulletin S1A37491.

**Figure 20: Pull-Apart Customer Terminal Block**

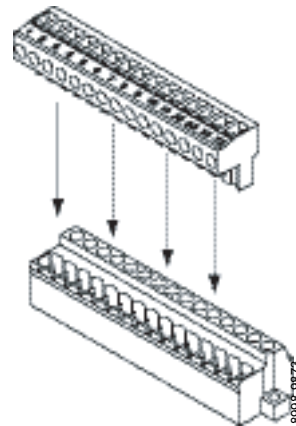

## Load Wiring

The motor load connections to the Enclosed 48 controller terminate on the ATS48 soft start controller. The load terminals are designated T1, T2, and T3. Refer to the Enclosed 48 controller wiring diagrams, nameplate, and bulletin S1A37491 for load terminal wire and torque requirements.

## Adaptation to Line Input

This paragraph replaces the information described in the “Adaptation to Line Input” section of bulletin S1A37491.

Each ATS48 soft start controller is factory configured for a particular line voltage as specified in the equipment order. The available ratings are: 208 Vac, 240 Vac, 480 Vac, and 600 Vac @ 60 Hz. The factory configured voltage rating is listed on the controller nameplate. Consult your Schneider Electric representative if the equipment requires modification from these voltage ratings.

The ATS48 soft start control transformer and overcurrent protective device (OCPD) may require change or reconfiguration.



## Section 4—Operation

### **⚠ DANGER**

#### **HAZARD OF ELECTRIC SHOCK, EXPLOSION, OR ARC FLASH**

Read and understand the precautions in “Before You Begin” starting on page 6 before performing the procedures in this section.

**Failure to follow these instructions will result in death or serious injury.**

### **⚠ WARNING**

#### **UNINTENDED EQUIPMENT OPERATION**

- Read and understand the *Altistart 48 Y-Range Soft Start Controllers Installation Guide* (S1A37491) before using the keypad display. Parameter changes affect drive controller operation. Most parameter changes require pressing ENT.
- Lock the keypad after making parameter adjustments.
- Do not reset soft start parameters to configurations other than those specified on the wiring diagrams supplied with the Enclosed 48 controller. Some factory-set drive parameters are critical for the Enclosed 48 controller power and control configurations.
- Do not alter the programming of factory-installed control devices or power contactors.

**Failure to follow these instructions can result in death or serious injury.**

For complete information about the operation of the ATS48 soft start, refer to bulletin S1A37491 and to the drawings supplied with the unit.

## Circuit Diagrams

The Enclosed 48 controller is an integrated package that can have different components and control schemes than those listed in bulletin S1A37491. Replace the “Recommended Wiring Diagrams” and “Recommended Components Lists” sections of bulletin S1A37491 with the documentation shipped with the Enclosed 48 units. Wiring diagrams specific to Enclosed 48 controllers are shipped with each unit. For component information, refer to the replacement parts list beginning on page 47 of this document, or consult your Schneider Electric representative.

## Integrated Full Voltage Bypass Starter (MOD A10)

Enclosed 48 controllers can include an optional full-voltage bypass starter which provides the ability to bypass the ATS48 soft start and run the motor using across-the-line, full-voltage starting. This mode of operation can be used when the ATS48 soft start is out of service due to a protective trip condition but the process needs to continue until a convenient shutdown is possible. Ensure that the electrical and mechanical systems are compatible with full-voltage starting before using the bypass starter.

The bypass circuit includes a “Bypass-Norm” (Bypass/Normal) selector switch mounted on the controller, control logic, and a separate

ambient-temperature compensated bimetallic or solid state overload relay (SSOLR). When the selector switch is in the Normal position, the ATS48 soft start controls the motor and the bypass contactor functions as a shorting contactor. The bypass contactor closes when the starting cycle is complete and opens when a stop command is given.

When the selector switch is in the Bypass position, the ATS48 soft start does not control the motor. The input contactor and the bypass contactor are directly opened and closed using a customer-supplied control.

## Factory Settings

The Enclosed 48 controller software is factory configured to match the power and control options purchased with the enclosed controller.

**NOTE:** Use caution when making changes to factory configured parameters. The factory settings are critical for the power and control options to function properly.

For more information about the Enclosed 48 controller factory settings, refer to Table 5. A wiring diagram is a part of the “Installation/Maintenance” packet included with your shipment.

**Before powering up the controller for the first time, compare the motor nameplate current rating with the output current (based on the horsepower and voltage rating) in Table 7 on page 37.** If the motor nameplate current rating is not within 40 to 100% of the value in the table, a different ATS48 soft start must be used.

**Table 5: Factory Configuration**

<b>Nominal motor current (<math>I_N</math>)</b>	Preset to correspond to 460 V rated motor current based on NFPA 70 / NEC Table 430.150 ratings
<b>Current Limit (ILt)</b>	400% of the motor current $I_N$
<b>Acceleration ramp (ACC)</b>	15 seconds
<b>Initial torque on starting (tq0)</b>	20% of the nominal torque
<b>Stop (StY)</b>	Freewheel stop (-F-)
<b>Motor thermal protection (tHP)</b>	Class 10 thermal overload protection curve (ATS48 soft start) Class 20 set to minimum threshold (MOD A10)
<b>Display</b>	rdY (ATS48 soft start ready) when power and control voltage are present and the motor is operating.
<b>Logic inputs</b>	<ul style="list-style-type: none"> <li>• LI1</li> <li>• LI2</li> <li>• LI3</li> <li>• LI4</li> </ul> <ul style="list-style-type: none"> <li>• STOP</li> <li>• RUN</li> <li>• Forced freewheel stop (LIA)</li> <li>• Forced local mode (LIL)</li> </ul>
<b>Logic outputs</b>	<ul style="list-style-type: none"> <li>• LO1</li> <li>• LO2</li> </ul> <ul style="list-style-type: none"> <li>• Motor thermal alarm (tA1)</li> <li>• Motor powered (rn)</li> </ul>
<b>Relay outputs</b>	<ul style="list-style-type: none"> <li>• R1</li> <li>• R2</li> <li>• R3</li> </ul> <ul style="list-style-type: none"> <li>• Detected fault relay (r1F)</li> <li>• Bypass relay at the end of starting</li> <li>• Motor powered (rn)</li> </ul>

**Table 5: Factory Configuration (continued)**

<b>Analog output (AO)</b>	Motor current (OCr, 0–20 mA)
<b>Communication parameters</b>	<ul style="list-style-type: none"> <li>When connected via the serial link, the soft starter has a logic address (Add) of 0</li> <li>Transmission speed (tbr): 19200 bits per second</li> <li>Communication format (FOR): 8 bits, no parity, 1 stop bit (8n1)</li> </ul>

## Minimum Start-up Procedure

Before operating the motor, check and adjust the following:

- The nominal motor current parameter
- The bimetallic motor overload relay or SSOLR (if a full voltage bypass starter, MOD A10, is provided)

Refer to the following sections for more information.

The nominal motor current parameter and all programmable Altistart 48 parameters can be adjusted via the keypad. An access switch on the back of the keypad provides three levels of access to the parameters: locked, partial unlocked, and unlocked. The switch is factory set to the locked position to help prevent accidental modification of the parameters. To access the parameters, open the Enclosed 48 controller door, locate the access switch, and set the switch to the unlocked position.

For more information, refer to the “Remote Keypad Display” section of bulletin S1A37491.

## Nominal Motor Current (I<sub>N</sub>)

The factory settings for the nominal motor current, I<sub>N</sub>, are listed in Table 7. If the factory setting is not within 95–105% of the motor nameplate current, or if using a 1.0 service factor motor, adjust the I<sub>N</sub> parameter to obtain optimal performance and thermal protection as specified in Table 6.

**Table 6: Service Factor Settings**

Service Factor	Setting
1.0	I <sub>N</sub> = 0.96 x Nameplate Current
1.15 or 1.25	I <sub>N</sub> = 1.00 x Nameplate Current

For 1.15 or 1.25 service factor motors, the nominal current may be set as high as 104% of the nameplate current if required to help prevent nuisance tripping.

**Table 7: Horsepower Ratings and Nominal Motor Current Factory Settings**

Altistart Soft Start Model	Horsepower Rating				Nominal Motor Current (I <sub>N</sub> ) Factory Setting
	208 V	230 V	460 V	575 V	
ATS48D17Y	3	5	10	15	14
ATS48D22Y	5	7.5	15	20	21
ATS48D32Y	7.5	10	20	25	27
ATS48D38Y	10	–	25	30	34
ATS48D47Y	–	15	30	40	40
ATS48D62Y	15	20	40	50	52
ATS48D75Y	20	25	50	60	65
ATS48D88Y	25	30	60	75	77
ATS48C11Y	30	40	75	100	96
ATS48C14Y	40	50	100	125	124
ATS48C17Y	50	60	125	150	156

**Table 7: Horsepower Ratings and Nominal Motor Current Factory Settings (continued)**

Altistart Soft Start Model	Horsepower Rating				Nominal Motor Current (I <sub>N</sub> ) Factory Setting
	208 V	230 V	460 V	575 V	
ATS48C21Y	60	75	150	200	180
ATS48C25Y	75	100	200	250	240
ATS48C32Y	100	125	250	300	302
ATS48C41Y	125	150	300	350	361
ATS48C48Y	150	–	350	400	414
ATS48C59Y	–	200	400	500	477
ATS48C66Y	200	250	500	600	660

**Motor Overload Relay (MOD A10 only)**

All Enclosed 48 controllers use the solid state thermal overload protection provided with the Altistart soft start. The bypass starter option provides an additional ambient-temperature compensated bimetallic overload relay or SSOLR for supplementary motor overload protection. Check the overload relay to verify that the current setting matches the actual motor full load amperes. All adjustable overload relays are factory set for the minimum trip setting.

Table 8 lists the catalog numbers of the motor overload relays provided with the MOD A10 option.

**Table 8: Enclosed 48 Controller Overload Relays**

Overload Relay Full Load Current in Amperes	Overload Relay Catalog Number <sup>1</sup>
9–13	LRD1516
12–18	LRD1521
17–25	LRD1522
23–28	LRD1532
30–40	LRD340
37–50	LRD350
48–65	LRD365
55–70	LR2D3561
63–80	LR2D3563
60–100	LR9F5567
90–150	LR9F5569
132–220	LR9F5571
200–330	LR9F7575
300–500	LR9F7579
380–630	LR9F7581

<sup>1</sup> Catalog numbers beginning with LR9 are SSOLR Type overload relays.

## Section 5—Maintenance

Before replacing any parts in the Enclosed 48 controller, read and understand the following safety messages and all other safety messages provided in this bulletin.

### Before You Begin

<b>⚠ DANGER</b>
<b>HAZARD OF ELECTRIC SHOCK, EXPLOSION, OR ARC FLASH</b>
<ul style="list-style-type: none"><li>• Read and understand this instruction bulletin before installing or operating the Enclosed 48 controller. Installation, adjustment, repair, and maintenance must be performed by qualified personnel.</li><li>• The user is responsible for compliance with all international and national electrical code requirements with respect to grounding of all equipment.</li><li>• Many parts of this drive controller, including the printed circuit boards, operate at the line voltage. DO NOT TOUCH. Use only electrically insulated tools.</li><li>• Some terminals have voltage on them when the disconnect is open.</li><li>• Install and close all covers and doors before applying power or starting and stopping the drive controller.</li></ul>
<b>Failure to follow these instructions will result in death or serious injury.</b>

Class 8638<sup>1</sup>

<b>⚠ DANGER</b>
<b>HAZARD OF ELECTRIC SHOCK, EXPLOSION, OR ARC FLASH</b>
<ul style="list-style-type: none"><li>• Apply appropriate personal protective equipment (PPE) and follow safe electrical work practices. See NFPA 70E.</li><li>• This equipment must only be installed and serviced by qualified electrical personnel.</li><li>• Never operate energized switch with door open.</li><li>• Turn off switch before removing or installing fuses or making load side connections.</li><li>• Always use a properly rated voltage sensing device at all line and load fuse clips to confirm switch is off.</li><li>• Turn off power supplying switch before doing any other work on or inside switch.</li><li>• Do not use renewable link fuses in fused switches.</li></ul>
<b>Failure to follow these instructions will result in death or serious injury.</b>

<sup>1</sup> This safety message refers to the Enclosed 48 controllers with a fusible disconnect (Class 8638). Unless otherwise specified, all other safety messages in this document refer to all Enclosed 48 controllers.

Class 8639

## **⚠ DANGER**

### **HAZARD OF ELECTRIC SHOCK, EXPLOSION, OR ARC FLASH**

- Apply appropriate personal protective equipment (PPE) and follow safe electrical work practices. See NFPA 70E.
- This equipment must only be installed and serviced by qualified electrical personnel.
- Turn off all power supplying this equipment before working on or inside equipment.
- Always use a properly rated voltage sensing device to confirm power is off.
- Replace all devices, doors and covers before turning on power to this equipment.

**Failure to follow these instructions will result in death or serious injury.**

## **⚠ DANGER**

### **UNINTENDED EQUIPMENT OPERATION**

Before turning on the Enclosed 48 controller or upon exiting the configuration menus, ensure that the inputs assigned to the Run command are in a state that will not cause the drive controller to run. Otherwise, the motor can start immediately.

**Failure to follow these instructions will result in death or serious injury.**

## **⚠ WARNING**

### **LOSS OF CONTROL**

- The designer of any control scheme must consider the potential failure modes of control paths and, for certain critical control functions, provide a means to achieve a safe state during and after a path failure. Examples of critical control functions are emergency stop and overtravel stop.
- Separate or redundant control paths must be provided for critical control functions.
- System control paths may include communication links. Consideration must be given to the implications of anticipated transmission delays or failures of the link<sup>1</sup>.
- Each implementation of an Enclosed 48 controller must be individually and thoroughly tested for proper operation before being placed into service.

**Failure to follow these instructions can result in death, serious injury, or equipment damage.**

<sup>1</sup> For additional information, refer to NEMA ICS 1.1 (latest edition), "Safety Guidelines for the Application, Installation, and Maintenance of Solid State Control" and to NEMA ICS 7.1 (latest edition), "Safety Standards for Construction and Guide for Selection, Installation and Operation of Adjustable-Speed Drive Systems."

## ⚠ CAUTION

### INCOMPATIBLE LINE VOLTAGE

Before turning on and configuring the Enclosed 48 controller, ensure that the line voltage is compatible with the line voltage range specified on the drive controller nameplate. The drive controller can be damaged if the line voltage is not compatible.

**Failure to follow these instructions can result in injury or equipment damage.**

## Power Fuse Recommendation

The Enclosed 48 controllers are provided with a circuit breaker or with a fusible switch disconnect.

Units supplied with fusible switch disconnects require the user to supply and install the power fuses. Select the fuses from Table 9. All of the Enclosed 48 controllers accept UL Class J or L fuses, depending on the full load current rating.

**NOTE:** Table 9 replaces the fuse recommendations and references to fuse type and size listed in bulletin S1A37491. Consult the fuse manufacturer derating curves before selecting fuses for ambient temperatures above 40 °C (104 °F). Consider that internal ambient temperatures are higher than external ambient temperatures. For typical wattage values, refer to Table 4 on page 30.

**Table 9: Power Fuse Selection for Enclosed 48 Controller with Fusible Switch Disconnect**

Motor Horsepower at				Recommended Square D Fuses		Altistart 48 Controller	
200 V	230 V	460 V	575 V	Power Fuse Class/Rating	Power Fuse Part Number	Fuse Manufacturer and Part Number	Soft Start Catalog Number
3	–	–	–	J/20A	25423-30200	Bussmann LPJ-20	ATS48D17Y
				J/20A	25423-20200	Littelfuse JTD-20	
				J/20A		Shawmut AJT-20	
–	5	10	–	J/25A	25423-30250	Bussmann LPJ-25	
				J/25A	25423-20250	Littelfuse JTD-25	
				J/25A		Shawmut AJT-25	
–	–	–	15	J/30A	25423-30300	Bussmann LPJ-30	
				J/30A	25423-20300	Littelfuse JTD-30	
				J/30A		Shawmut AJT-30	
5	–	–	–	J/30A	25423-30300	Bussmann LPJ-30	
				J/30A	25423-20300	Littelfuse JTD-30	
				J/30A		Shawmut AJT-30	
–	–	15	–	J/35A	25423-30350	Bussmann LPJ-35	ATS48D22Y
				J/35A		Littelfuse JTD-35	
				J/35A		Shawmut AJT-35	
–	7.5	–	20	J/40A	25423-30400	Bussmann LPJ-40	
				J/40A	25423-20400	Littelfuse JTD-40	
				J/40A		Shawmut AJT-40	

**Table 9: Power Fuse Selection for Enclosed 48 Controller with Fusible Switch Disconnect (continued)**

Motor Horsepower at				Recommended Square D Fuses		Altistart 48 Controller		
200 V	230 V	460 V	575 V	Power Fuse Class/Rating	Power Fuse Part Number	Fuse Manufacturer and Part Number	Soft Start Catalog Number	
7.5	-	20	25	J/45A	25423-30450	Bussmann LPJ-45	ATS48D32Y	
				J/45A		Littelfuse JTD-45		
				J/45A		Shawmut AJT-45		
-	10	-	-	J/50A	25423-30500	Bussmann LPJ-50		
				J/50A	25423-20500	Littelfuse JTD-50		
				J/50A		Shawmut AJT-50		
10	-	-	-	J/50A	25423-30500	Bussmann LPJ-50		ATS48D38Y
				J/50A	25423-20500	Littelfuse JTD-50		
				J/50A		Shawmut AJT-50		
-	-	25	30	J/60A	25423-30600	Bussmann LPJ-60		
				J/60A	25423-20600	Littelfuse JTD-60		
				J/60A		Shawmut AJT-60		
-	15	30	40	J/70A	25423-30700	Bussmann LPJ-70	ATS48D47Y	
				J/70A	25423-20700	Littelfuse JTD-70		
				J/70A		Shawmut AJT-70		
15	-	-	-	J/80A	25423-30800	Bussmann LPJ-80		ATS48D62Y
				J/80A	25423-20800	Littelfuse JTD-80		
				J/80A		Shawmut AJT-80		
-	20	40	50	J/90A	25423-30900	Bussmann LPJ-90		
				J/90A	25423-20900	Littelfuse JTD-90		
				J/90A		Shawmut AJT-90		
20	-	-	-	J/100A	25423-31000	Bussmann LPJ-100	ATS48D75Y	
				J/100A	25423-21000	Littelfuse JTD-100		
				J/100A		Shawmut AJT-100		
-	-	50	60	J/110A	25423-31100	Bussmann LPJ-110		
				J/110A	25423-21100	Littelfuse JTD-110		
				J/110A		Shawmut AJT-110		
-	25	-	-	J/125A	25423-31250	Bussmann LPJ-125		ATS48D88Y
				J/125A	25423-21250	Littelfuse JTD-125		
				J/125A		Shawmut AJT-125		
25	-	60	75	J/125A	25423-31250	Bussmann LPJ-125		
				J/125A	25423-21250	Littelfuse JTD-125		
				J/125A		Shawmut AJT-125		
-	30	-	-	J/150A	25423-31500	Bussmann LPJ-150	ATS48C11Y	
				J/150A	25423-21500	Littelfuse JTD-150		
				J/150A		Shawmut AJT-150		
30	-	-	-	J/150A	25423-31500	Bussmann LPJ-150		
				J/150A	25423-21500	Littelfuse JTD-150		
				J/150A		Shawmut AJT-150		
-	40	75	100	J/175A	25423-31750	Bussmann LPJ-175		ATS48C14Y
				J/175A	25423-21750	Littelfuse JTD-175		
				J/175A		Shawmut AJT-175		
40	-	-	-	J/200A	25423-32000	Bussmann LPJ-200		
				J/200A	25423-22000	Littelfuse JTD-200		
				J/200A		Shawmut AJT-200		
-	50	100	125	J/225A	25423-32250	Bussmann LPJ-225		
				J/225A	25423-22250	Littelfuse JTD-225		
				J/225A		Shawmut AJT-225		

**Table 9: Power Fuse Selection for Enclosed 48 Controller with Fusible Switch Disconnect (continued)**

Motor Horsepower at				Recommended Square D Fuses		Altistart 48 Controller	
200 V	230 V	460 V	575 V	Power Fuse Class/Rating	Power Fuse Part Number	Fuse Manufacturer and Part Number	Soft Start Catalog Number
50	60	125	150	J/250A	25423-32500	Bussmann LPJ-250	ATS48C17Y
				J/250A	25423-22500	Littelfuse JTD-250	
				J/250A		Shawmut AJT-250	
60	-	150	-	J/300A	25423-33000	Bussmann LPJ-300	ATS48C21Y
				J/300A	25423-23000	Littelfuse JTD-300	
				J/300A		Shawmut AJT-300	
-	75	-	200	J/350A	25423-33500	Bussmann LPJ-350	ATS48C25Y
				J/350A	25423-23500	Littelfuse JTD-350	
				J/350A		Shawmut AJT-350	
75	-	-	-	J/350A	25423-33500	Bussmann LPJ-350	ATS48C25Y
				J/350A	25423-23500	Littelfuse JTD-350	
				J/350A		Shawmut AJT-350	
-	100	200	250	J/400A	25423-34000	Bussmann LPJ-400	ATS48C32Y
				J/400A	25423-24000	Littelfuse JTD-400	
				J/400A		Shawmut AJT-400	
100	-	-	-	J/450A	25423-34500	Bussmann LPJ-450	ATS48C32Y
				J/450A	25423-24500	Littelfuse JTD-450	
				J/450A		Shawmut AJT-450	
-	125	250	300	J/500A	25423-35000	Bussmann LPJ-500	ATS48C41Y
				J/500A	25423-25000	Littelfuse JTD-500	
				J/500A		Shawmut AJT-500	
125	150	300	350	J/600A	25423-36000	Bussmann LPJ-600	ATS48C41Y
				J/600A	25423-26000	Littelfuse JTD-600	
				J/600A		Shawmut AJT-600	
150	-	350	400	L/700A	25432-10700	Bussmann KRP-C-700	ATS48C48Y
				L/700A		Littelfuse KLP-C-700	
				L/700A		Shawmut A4BQ-700	
-	200	400	500	L/800A	25432-10800	Bussmann KRP-C-800	ATS48C59Y
				L/800A		Littelfuse KLP-C-800	
				L/800A		Shawmut A4BQ-800	
200	-	-	-	L/900A	25432-10900	Bussmann KRP-C-900	ATS48C66Y
				L/900A		Littelfuse KLP-C-900	
				L/900A		Shawmut A4BQ-900	
-	250	500	600	L/1000A	25432-11000	Bussmann KRP-C-1000	ATS48C66Y
				L/1000A		Littelfuse KLP-C-1000	
				L/1000A		Shawmut A4BQ-1000	

## Technical Support

When troubleshooting the Class 8638 or Class 8639 Enclosed 48 controller, discuss with the operating personnel the symptoms of the reported problem. Ask them to describe the problem, when they first observed the problem, and where the problem was seen. Observe directly the controller and process. Record the controller, motor, and peripheral equipment nameplate data on the “Altistart 48 Class 8638/8639 Enclosed Controllers Troubleshooting Sheet” on page 45. (You may copy this form as needed.)

The Drives Product Support Group (DPSG) provides field sales, distributors, OEMs, contractors, and end users with AC drive and soft starter technical assistance. Support includes equipment selection, programming, communications, and other troubleshooting assistance. The support group may be contacted as follows:

- Phone (toll free): 1-888-778-2733 Monday–Friday 8 a.m. to 8 p.m. ET (after-hours emergency support is available)
- Fax: 919-217-6508
- E-mail: [drive.products.support@schneider-electric.com](mailto:drive.products.support@schneider-electric.com)

Contact the DPSG for all product-related technical support questions. If the reported incident cannot be resolved, the support engineer will direct you to the functional group that can best provide a resolution. Each incident inquiry is assigned a case number, which is critical for tracking the history of the incident, for dispatching services, and for warranty evaluations.

**Figure 21: Altistart 48 Class 8638/8639 Enclosed Controllers Troubleshooting Sheet**

When requesting after-sales service, it is important to disclose all conditions under which the Square D / Schneider Electric equipment currently operates. This will help in diagnosing the system quickly.

FAX to: **TECHNICAL SUPPORT at 919-217-6508**

DATE: \_\_\_\_\_  
 CONTACT NAME: \_\_\_\_\_  
 COMPANY: \_\_\_\_\_  
 ADDRESS: \_\_\_\_\_  
 CITY: \_\_\_\_\_  
 STATE: \_\_\_\_\_  
 PHONE: \_\_\_\_\_  
 FAX: \_\_\_\_\_

**ENCLOSED 48 CONTROLLER CONFIGURATION**

Class: \_\_\_\_\_ Type: \_\_\_\_\_ Forms: \_\_\_\_\_  
 Factory Order Number / Q2C Number: \_\_\_\_\_  
 Application/Equipment Designation: \_\_\_\_\_

**MOTOR NAMEPLATE DATA**

Horsepower: \_\_\_\_\_ Voltage (3 Phase): \_\_\_\_\_ Frequency: \_\_\_\_\_ Poles: \_\_\_\_\_ FLA: \_\_\_\_\_  
 Service Factor: \_\_\_\_\_ Motor Type/Design: \_\_\_\_\_ o NEMA A o NEMA B o NEMA C o NEMA D  
 Motor Cable Type: \_\_\_\_\_ Approximate Cable Length (in Feet): \_\_\_\_\_

**POWER SOURCE AND ENVIRONMENT**

Voltage Between L1 and L2: \_\_\_\_\_ Voltage Between L2 and L3: \_\_\_\_\_ Voltage Between L3 and L1: \_\_\_\_\_  
 Service Transformer Rating: \_\_\_\_\_ kVA, \_\_\_\_\_ % Z Frequency: o 60 Hz or o 50 Hz  
 Ambient Temperatures: \_\_\_\_\_ Min. °C (°F) \_\_\_\_\_ Max. °C (°F) Humidity: \_\_\_\_\_  
 Altitude if greater than 3300 feet above sea level, specify: \_\_\_\_\_ ft

**ATS48 SOFT START CONTROLLER DETECTED FAULT AND EVENT CODES**

Refer to "Detected Fault and Operating Condition Management" in bulletin S1A37491 for possible causes and corrective action

Requires a Power Reset	Auto-Reset Conditions (Customer Configurable)	Requires a RUN Command Reset	
<input type="checkbox"/> InF, Internal Analysis Needed	<input type="checkbox"/> PHF, Loss of Phase or Loss of Motor Phase	<input type="checkbox"/> SLF, Serial Link Interruption	<input type="checkbox"/> OHF, Starter Thermal Trip
<input type="checkbox"/> OCF, Overcurrent		<input type="checkbox"/> ETF, External Event	<input type="checkbox"/> OTF, Motor Thermal Trip Via PTC Probes
<input type="checkbox"/> PIF, Phase Inversion	<input type="checkbox"/> FRF, Line Frequency (out of tolerance)	<input type="checkbox"/> STF, Excessive Starting Time	<input type="checkbox"/> ULF, Motor Underload
<input type="checkbox"/> EEF, Internal Memory	<input type="checkbox"/> USF, Power Supply	<input type="checkbox"/> OLC, Current Overload	<input type="checkbox"/> LRF, Locked Rotor (in steady state)
	<input type="checkbox"/> CLF, Control Line Interruption (CL1/CL2)	<input type="checkbox"/> OLF, Motor Thermal Trip	
<b>Auto-Reset Conditions When Causes Disappear</b>	<input type="checkbox"/> CFF, Invalid Configuration (power up)	<input type="checkbox"/> CFI, Invalid Configuration (COMM)	

Detailed description of problem (attach wiring diagram/schematics if applicable):

\_\_\_\_\_  
 \_\_\_\_\_  
 \_\_\_\_\_  
 \_\_\_\_\_



## Section 6—Replacement Parts

**⚠ DANGER**

**HAZARD OF ELECTRIC SHOCK, EXPLOSION, OR ARC FLASH**

- Refer to “Before You Begin” starting on page 4 before performing the procedures in this section.
- For controllers with fusible switch disconnects, use only the Class J or Class L fuses listed in Table 9 on page 41 to provide correct short-circuit protection.

**Failure to follow these instructions will result in death or serious injury.**

For the ATS48 soft start replacement parts, refer to bulletin S1A37491. Refer to the Table 10 for additional replacement parts used in the Enclosed 48 controllers. Order all parts from your local supplier of Square D brand parts.

**Table 10: Replacement Parts for Enclosed 48 Controllers**

Part Description	Motor Horsepower at				Rating A	Catalog No.
	208 V	230 V	460 V	575 V		
Automatic Molded Case Switch	3–30	5–40	10–75	15–125	150 A	HLL36000LV
	40	—	100	150	175 A	JLL3600017LV
	50, 60	50 to 75	125, 150	—	250 A	JLL3600025LV
	75, 100	100, 125	200, 250	200–300	400 A	LHL36000MV
	125, 150	150, 200	300–400	—	600 A	PLL34000S60
	200	250	500	—	800 A	PLL34000S80
	—	—	—	350–500	—	PKL36000S60
	—	—	—	600	—	PKL36000S80
Shunt Trip Automatic Molded Case Switch	3–30	5–40	10–75	15–125	150 A	HLL36000SALV
	40	—	100	150	175 A	JLL3600017SALV
	50, 60	50–75	125, 150	—	250 A	JLL3600025SALV
	75, 100	100, 125	200, 250	200–300	400 A	LHL36000MV1021
	125, 150	150, 200	300–400	—	600 A	PLL34000S60SA
	200	250	500	—	800 A	PLL34000S80SA
	—	—	—	350–500	—	PKL36000S60SA
	—	—	—	600	—	PKL36000S80SA
Operator Mechanisms	3–50	5–60	10–75	15–125	—	80439-403-52
	60	75	100	150	—	80439-403-53
	75, 100	100, 125	200, 250	200–300	—	80439-954-50
	125, 150	150, 200	300–400	—	—	80439-991-50
	200	250	500	—	—	80439-991-50
	—	—	—	350–500	—	80439-991-50
	—	—	—	600	—	80439-991-50

**Table 10: Replacement Parts for Enclosed 48 Controllers** *(continued)*

Part Description	Motor Horsepower at				Rating A	Catalog No.
	208 V	230 V	460 V	575 V		
IEC Shorting Contactors (AC-1)	3–7.5	5–10	10–20	15–25	25 A Contactor	LC1D25G7
	10–15	15	25–30	30–40	32 A Contactor	LC1D32G7
	—	20	40	50	40 A Contactor	LC1D40AG7
	20–25	25	50	60	50 A Contactor	LC1D50AG7
	30–40	30–40	60–75	75–100	80 A Contactor	LC1D80G7
	50	50–60	100–125	125–150	115 A Contactor	LC1D115G7
	60	75	150	200	150 A Contactor	LC1D150G7
	75	100	200	250	185 A Contactor	LC1F185
	75	100	200	250	120 V / 60 Hz Coil (F185)	LX1FG095
	100	—	—	—	265 A Contactor	LC1F265
	100	—	—	—	120 V Coil (F265)	LX1FH1272
	125	125	250	300–350	330 A Contactor	LC1F330
	125	125	250	300–350	120 V Coil (F330)	LX1FH1272
	150	150	300–350	400	400 A Contactor	LC1F400
	150	150	300–350	400	120 V Coil (F400)	LX1FJ110
	200	200	400	500–600	500 A Contactor	LC1F500
	200	200	400	500–600	120 V Coil (F500)	LX1FK110
	—	250	500	—	630 A Contactor	LC1F630
	—	250	500	—	120 V Coil (F630)	LX1FL110
IEC Isolation Contactors (AC-3)	3–5	5	10–15	15–20	25 A Contactor	LC1D25G7
	7.5	7.5–10	20	25	32 A Contactor	LC1D32G7
	10	—	25	30	40 A Contactor	LC1D40AG7
	15	15	30	40	50 A Contactor	LC1D50AG7
	20	20	40	50	65 A Contactor	LC1D65AG7
	—	25	50	60	80 A Contactor	LC1D80G7
	25–30	30–40	60–75	75–100	115 A Contactor	LC1D115G7
	40	50	100	125	150 A Contactor	LC1D150G7
	50–60	60	125	150	185 A Contactor	LC1F185
	50–60	60	125	150	120 V / 60 Hz Coil (F185)	LX1FG095
	75	75	150	200	225 A Contactor	LC1F225
	75	75	150	200	120 V / 60 Hz Coil (F225)	LX1FG095
	—	100	200	250	265 A Contactor	LC1F265
	—	100	200	250	120 V Coil (F265)	LX1FG095
	100	125	250	300	330 A Contactor	LC1F330
	100	125	250	300	120 V Coil (F330)	LX1FH1272
	125	150	300	250	400 A Contactor	LC1F400
	125	150	300	250	120 V Coil (F400)	LX1FJ110
	150	—	350	400–500	500 A Contactor	LC1F500
	150	—	350	400–500	120 V Coil (F500)	LX1FK110
200	200–250	400–500	600	630 A Contactor	LC1F630	
200	200–250	400–500	600	120 V Coil (F630)	LX1FI10	

**Table 10: Replacement Parts for Enclosed 48 Controllers (continued)**

Part Description	Motor Horsepower at				Rating A	Catalog No.
	208 V	230 V	460 V	575 V		
<b>Circuit Breakers</b>	3	—	—	—	20 A	HLL36020LV
	—	—	10	—	25 A	HLL36025LV
	5	5	—	—	30 A	HLL36030LV
	—	—	15	—	40 A	HLL36040LV
	7.5	7.5	—	—	45 A	HLL36045LV
	—	10	20	—	50 A	HLL36050LV
	10	—	25	—	60 A	HLL36060LV
	—	15	30	—	80 A	HLL36080LV
	15, 20, 25	20, 25, 30	40, 50, 60	—	110 A	HLL36110LV
	30	—	75	—	125 A	HLL36125LV
	—	40	—	—	150 A	HLL36150LV
	40	—	—	—	175 A	JLL36175LV
	50	50	100	—	200 A	JLL36200LV
	—	60	125	—	225 A	JLL36225LV
	60	—	—	—	400 A	LHL3640031M
	—	75	150	—	400 A	LHL3640032M
	75	100	—	—	400 A	LHL3640033M
	100	125	200	—	400 A	LHL3640035M
	—	—	250	—	400 A	LHL3640036M
	125, 150	150	300, 350	—	600 A	MJL36600
125, 150*	150*	300, 350*	—	600 A	PLL34060	
200	200	400	—	800 A	MJL36800	
200*	200*	400*	—	800 A	PLL34080	
—	250	500	—	1000 A	PLL34100	
<b>Shunt Trip Circuit Breakers</b>	3	—	—	—	20 A	HLL36020SALV
	—	—	10	—	25 A	HLL36025SALV
	5	5	—	—	30 A	HLL36030SALV
	—	—	15	—	40 A	HLL36040SALV
	7.5	7.5	—	—	45 A	HLL36045SALV
	—	10	20	—	50 A	HLL36050SALV
	10	—	25	—	60 A	HLL36060SALV
	—	15	30	—	80 A	HLL36080SALV
	15, 20, 25	20, 25, 30	40, 50, 60	—	110 A	HLL36110SALV
	30	—	75	—	125 A	HLL36125SALV
	—	40	—	—	150 A	HLL36150SALV
	40	—	—	—	175 A	JLL36175SALV
	50	50	100	—	200 A	JLL36200SALV
	—	60	125	—	225 A	JLL36225SALV
	60	—	—	—	400 A	LHL3640031M1021
	—	75	150	—	400 A	LHL3640032M1021
	75	100	—	—	400 A	LHL3640033M1021
	100	125	200	—	400 A	LHL3640035M1021
	—	—	250	—	400 A	LHL3640036M1021
	125, 150	150	300, 350	—	600 A	MJL36600SA
125, 150*	150*	300, 350*	—	600 A	PLL34060SA	
200	200	400	—	800 A	MJL36800SA	
200*	200*	400*	—	800 A	PLL34080SA	
—	250	500	—	1000 A	PLL34100SA	

**Table 10: Replacement Parts for Enclosed 48 Controllers** *(continued)*

Part Description	Motor Horsepower at				Rating A	Catalog No.
	208 V	230 V	460 V	575 V		
<b>Mechanical Interlocks for Contactors</b>	3–7.5	5–10	10–20	15–25	D09–D32 Contactors	LAD9R1V
	10–20	15–25	25–50	30–60	D40–D65 Contactors	LA9D4002
	25–50	30–50	60–100	75–150	D115–D150 Contactors	LA9D11502
	—	60	125	—	F185–F225 Contactors (horizontally mounted)	LA9FG970
	60–75	75	150	200	F185–F225 Contactors (vertically mounted)	LA9FG4G
	100	100–125	200–250	250–300	F265–F330 Contactors (vertically mounted)	LA9FH4H
	125	—	300	350	F400 Contactors (vertically mounted)	LA9FJ4J
	150	150	350	400–500	F500 Contactors (vertically mounted)	LA9FK4K
	200	200–250	400–500	600	F630 Contactors (vertically mounted)	LA9FL4L
<b>Overload Relays</b>	3	—	—	—	9–13 A	LRD1516
	5	5	10	15	12–18 A	LRD1521
	7.5	7.5	15	20	17–25 A	LRD1522
	—	10	20	25	25–32 A	LRD1532
	10	—	25	30	30–40 A	LR2D3555
	15	15	30	40	37–50 A	LR2D3557
	20	20	40	50	48–65 A	LR2D3559
	—	—	50	60	55–70 A	LR2D3561
	—	25	—	—	63–80 A	LR2D3563
	25–30	30	60	75	60–100 A	LR9D5567
	40	40–50	75–100	100–125	90–150 A	LR9D5569
	50–75	60–75	125–150	150–200	132–220 A	LR9F5571
	100	100–125	200–250	250–300	200–330 A	LR9F7575
	125–150	150	300–350	350–400	300–500 A	LR9F7579
200	200–250	400–500	500–600	380–630 A	LR9F7581	

Table 10: Replacement Parts for Enclosed 48 Controllers (continued)

Part Description	Motor Horsepower at				Rating A	Catalog No.
	208 V	230 V	460 V	575 V		
IEC Reversing Isolation Contactors (AC-3)	3–5	5	10–15	15–20	25A Contactor	LCD25G7
	7.5	7.5–10	20	25	32A Contactor	LC2D32G7
	10	—	25	30	40A Contactor	LC2D40G7
	15	15	30	40	50A Contactor	LC2D50G7
	20	20	40	50	65A Contactor	LC2D65G7
	25	25	50	60	80A Contactor	LC2D80G7
	30	30–40	60–75	75–100	115A Contactor	LC2D115G7
	40	50	100	125	150A Contactor	LC2D150G7
	50–60	60	125	150	185A Contactor	LC2F185
	50–60	60	125	150	120V/60Hz Coil (F185)	LX1FG095
	75	75	150	200	225A Contactor	LC2F225
	75	75	150	200	120V/60Hz Coil (F225)	LX1FG095
	—	100	200	250	265A Contactor	LC2F265
	—	100	200	250	120V Coil (F265)	LX1FG095
	100	125	250	300	330A Contactor	LC2F330
	100	125	250	300	120V Coil (F330)	LX1FH1272
	125	—	300	350	400A Contactor	LC2F400
	125	150	300	350	120V Coil (F400)	LX1FJ110
	150	150	350	400–500	500A Contactor	LC2F500
	150	—	350	400–500	120V Coil (F500)	LX1FK110
200	—	400–500	600	630A Contactor	LC2F630	
200	200–250	400–500	600	120V Coil (F630)	LX1FL110	
IEC FV Bypass Contactors (AC-3)	3–5	—	10–15	15–20	25A Contactor	LC1D2G7
	7.5	5	20	25	32A Contactor	LC1D32G7
	10	7.5–10	25	30	40A Contactor	LC1D40G7
	15	—	30	40	50A Contactor	LC1D50G7
	20	15	40	50	65A Contactor	LC1D65G7
	—	20	50	60	80A Contactor	LC1D80G7
	25–30	25	60–75	75–100	115A Contactor	LC1D115G7
	40	30–40	100	125	150A Contactor	LC1D150G7
	50–60	50	125	150	185A Contactor	LC1F185
	50–60	60	125	150	120V/60Hz Coil (F185)	LX1FG095
	75	75	150	200	225A Contactor	LC1F225
	75	75	150	200	120V/60Hz Coil (F225)	LX1FG095
	—	100	200	250	265A Contactor	LC1F265
	—	100	200	250	120V Coil (F265)	LX1FG095
	100	125	250	300	330A Contactor	LC1F330
	100	125	250	300	120V Coil (F330)	LX1FH1272
	125	150	300	350	400A Contactor	LC1F400
	125	150	300	350	120V Coil (F400)	LX1FJ110
	150	—	350	400–500	500A Contactor	LC1F500
	150	—	350	400–500	120V Coil (F500)	LX1FK110
200	200–250	400–500	600	630A Contactor	LC1F630	
200	200–250	400–500	600	120V Coil (F630)	LX1FL110	





**Altistart™ 48 Enclosed Soft Start Controllers  
Instruction Bulletin**

**Schneider Electric**  
1415 S. Roselle Road  
Palatine, IL 60067 USA  
1-888-778-2733  
[www.schneider-electric.us](http://www.schneider-electric.us)

Electrical equipment should be installed, operated, serviced, and maintained only by qualified personnel. No responsibility is assumed by Schneider Electric for any consequences arising out of the use of this material.

© 2004–2014 Schneider Electric. All Rights Reserved  
Altistart, Schneider Electric and Square D are trademarks owned by Schneider Electric Industries SAS or its affiliated companies. All other trademarks are the property of their respective owners.

30072-450-62 Rev. 02, 02/2014  
Replaces 30072-450-62B, 03/2009