



**POWER
MEASUREMENT**

creator of ION® technology

Installation & Operation Manual

3710 ACM

Notices

For further assistance
please contact us at:



Worldwide Headquarters

2195 Keating Cross Road
Saanichton, BC
Canada V8M 2A5
Tel: 1-250-652-7100
Fax: 1-250-652-0411
Email: support@pwr.com

www.pwr.com

© 2005 Power Measurement
Printed in Canada
Revision Date: Feb. 1, 2005
70000-0007-04

Danger



This symbol indicates the presence of dangerous voltage within and outside the product enclosure that may constitute a risk of electric shock, serious injury or death to persons if proper precautions are not followed.

Caution



This symbol alerts the user to the presence of hazards that may cause minor or moderate injury to persons, damage to property or damage to the device itself, if proper precautions are not followed.

Note



This symbol directs the user's attention to important installation, operating and maintenance instructions.

Installation Considerations

Installation and maintenance of the 3710 ACM meter should only be performed by qualified, competent personnel that have appropriate training and experience with high voltage and current devices. The meter must be installed in accordance with all Local and National Electrical Codes.

DANGER

Failure to observe the following instructions may result in severe injury or death.

- ◆ During normal operation of the 3710 ACM meter, hazardous voltages are present on its terminal strips, and throughout the connected potential transformer (PT), current transformer (CT), digital (status) input, control power and external I/O circuits. PT and CT secondary circuits are capable of generating lethal voltages and currents with their primary circuit energized. Follow standard safety precautions while performing any installation or service work (i.e. removing PT fuses, shorting CT secondaries, etc).
- ◆ The terminal strips on the meter base should not be user-accessible after installation.
- ◆ Do not use digital output devices for primary protection functions. These include applications where the devices perform energy limiting functions or provide protection of people from injury. Do not use the 3710 ACM in situations where failure of the devices can cause injury or death, or cause sufficient energy to be released that can start a fire. The meter can be used for secondary protection functions.
- ◆ Do not HIPOT/Dielectric test the digital (status) inputs, digital outputs, or communications terminals. Refer to the label on the 3710 ACM meter for the maximum voltage level the device can withstand.

CAUTION

Observe the following instructions, or permanent damage to the meter may occur.

- ◆ The 3710 ACM meter offers a range of hardware options that affect input ratings. The 3710 ACM meter's serial number label lists all equipped options. Applying current levels incompatible with the current inputs will permanently damage the meter. This document provides installation instructions applicable to each hardware option.
- ◆ The 3710 ACM meter's chassis ground must be properly connected to the switchgear earth ground for the noise and surge protection circuitry to function correctly. Failure to do so will void the warranty.
- ◆ Terminal screw torque: Barrier-type (current, voltage, and relay terminal screws): 1.35 Nm (1.00 ft-lbf) max. Captured-wire type (digital inputs/outputs, communications, power supply): 0.90 Nm (0.66 ft.lbf) max.

FCC Notice

This equipment has been tested and found to comply with the limits for a Class A digital device, pursuant to Part 15 of the FCC Rules. These limits are designed to provide reasonable protection against harmful interference when the equipment is operated in a commercial environment. This equipment generates, uses, and can radiate radio frequency energy and, if not installed and used in accordance with the instruction manual, may cause harmful interference to radio communications. Operation of this equipment in a residential area is likely to cause harmful interference in which case the user will be required to correct the interference at his own expense. The Ringer Equivalence Number (REN) for the 3710 ACM optional internal modem is 0.6. Connection to the 3710 ACM internal modem should be made via an FCC Part 68 compliant telephone cord (not supplied). The 3710 ACM cannot be used on a public coin phone service or party line services.

Network Compatibility Notice for the Internal Modem

The internal modem in meters equipped with this option is compatible with the telephone systems of most countries in the world, with the exception of Australia and New Zealand. Use in some countries may require modification of the internal modem's initialization strings. If problems using the modem on your phone system occur, please contact Power Measurement Technical Services

Standards Compliance



CSA certified
LR 57329



UL recognized
E95810

Limitation of Liability

Power Measurement Ltd. ("Power Measurement") reserves the right to make changes in the device or its specifications identified in this document without notice. Power Measurement advises customers to obtain the latest version of the device specifications before placing orders to verify that the information being relied upon by the customer is current.

Regardless of whether any remedy set forth herein fails of its essential purpose, except to the extent the following limitation is prohibited by applicable law, Power Measurement shall not, in any event or under any legal claim or theory (whether based on contract, indemnity, warranty, tort (including negligence and strict liability) or otherwise), be liable to the original purchaser or any other person or entity for special, indirect, incidental, punitive, liquidated, special or consequential damages whatsoever with respect to any purchased product, including, without limitation, business interruption, loss of use, profit or revenue, even if Power Measurement has been advised of the possibility of such damages. To the extent that a limitation or exclusion of consequential damages are prohibited by applicable law, then Power Measurement's liability shall be limited to twice the amount of the relevant purchased product. Not to limit the foregoing, a) Power Measurement shall not be liable for any claim (other than a claim solely for the breach of one of the above Warranties that is made in accordance with the above described procedures) made by the original purchaser, its employees, agents, or contractors for any loss, damage, or expense incurred due to, caused by, or related to any purchased product; and b) the above Warranties are the original purchaser's exclusive remedy and Power Measurement hereby expressly disclaims all other warranties, express or implied, including, without limitation, warranties of non-infringement and the implied warranties of merchantability and fitness for a particular purpose.

These limited Warranties shall not apply to any product that has been subject to alteration, accident, misuse, abuse, neglect or failure to exactly follow Power Measurement's instructions for operation and maintenance. Any technical assistance provided by Power Measurement's personnel or representatives in system design shall be deemed to be a proposal and not a recommendation. The responsibility for determining the feasibility of such proposals rests with the original purchaser and should be tested by the original purchaser. It is the original purchaser's responsibility to determine the suitability of any product and associated documentation for its purposes. The original purchaser acknowledges that 100% "up" time is not realizable because of possible hardware or software defects. The original purchaser recognizes that such defects and failures may cause inaccuracies or malfunctions. Only the terms expressed in these limited Warranties shall apply and no distributor, corporation or other entity, individual or employee of Power Measurement or any other entity is authorized to amend, modify or extend the Warranties in any way.

The information contained in this document is believed to be accurate at the time of publication, however, Power Measurement assumes no responsibility for any errors which may appear here and reserves the right to make changes without notice.

Power Measurement, ION, ION Enterprise, MeterM@il, WebMeter and "drive energy performance" are either registered trademarks or trademarks of Power Measurement. All other trademarks are property of their respective owners.

Covered by one or more of the following patents:

U.S. Patent No's 6792364, 6792337, 6751562, 6745138, 6737855, 6694270, 6687627, 6671654, 6671635, 6615147, 6611922, 6611773, 6563697, 6493644, 6397155, 6186842, 6185508, 6000034, 5995911, 5828576, 5736847, 5650936, D459259, D458863, D443541, D439535, D435471, D432934, D429655, D429533, D427533.

DISPLAY TIMEOUT This device has a *display timeout* feature which automatically turns off the front panel display after a programmable timeout period. When the device is shipped, this timeout period is preset to 180 minutes (3 hours). Following a display timeout, you can turn the display back on by pressing any button on the front panel.

The REV B release of the 3710 ACM differs significantly from the earlier REV A release. Many terminal connections have been altered or modified in their positions or functions. The two releases can be easily differentiated. On models with a front panel display, the REV B version has a dark grey plastic bezel surrounding the faceplate. On all models, the serial number label found on the rear panel of the unit indicates the release. REV B differs functionally from REV A as follows:

- a) Power supply terminals (L/+ and N/-) have been repositioned.
- b) Voltage reference terminal (VREF) has been added as the reference for phase voltage sense inputs. Refer to Section 2.9 for description.
- c) Earth ground terminal (G) has been removed and replaced by a chassis ground lug, attached to one of the mounting studs/holes. Refer to Section 2.10 for description.
- d) Status input terminals have been repositioned. SCOM terminal has been added as the common for all status inputs. Refer to Section 2.8 for description.

Table of Contents

1	INTRODUCTION	
2	INSTALLATION	
2.1	Location & Mounting	2-1
2.2	General Wiring Considerations	2-2
2.3	Power Supply Connections	2-2
2.4	Chassis Ground Connection	2-2
2.5	Phase Voltage and Phase Current Input Connections	2-2
2.5.1	Phase Voltage Inputs	2-2
2.5.2	Phase Current Inputs	2-3
2.5.3	PT & CT Connection	2-4
2.5.4	Voltage Reference Connection	2-4
2.5.5	Waveform Capture Connections	2-4
2.5.6	I4 Current Input Connections	2-4
2.5.7	Connection for Three Phase Wye (Star) Systems	2-5
2.5.8	Connection for Three Phase Delta Systems	2-9
2.5.9	Connection for Single Phase Systems	2-11
2.6	Communications Connections	2-12
2.6.1	Introduction	2-12
2.6.2	Configuration of the Communication Card	2-12
2.6.3	Terminal and LED Functions	2-13
2.6.4	RS-232 Connections	2-14
2.6.5	RS-485 Connections	2-16
2.7	Control Relay Connections	2-20
2.7.1	Relay Application Precautions	2-21
2.7.2	Form-C Relays	2-21
2.7.3	Solid State Relays	2-22
2.8	Status Input Connections	2-23
2.8.1	Introduction	2-23
2.8.2	Dry (Volts Free) Contact Sensing	2-23
2.8.3	Voltage Sensing	2-25
2.9	Auxiliary Voltage Input Connections	2-26
2.10	Auxiliary Current Output Connections	2-27
2.11	Maintenance	2-27
2.12	Field Service Considerations	2-27
3	GENERAL OPERATION	
3.1	Introduction	3-1
3.2	Power Up	3-1
3.3	Display Mode	3-1
3.3.1	Front Panel Display	3-1
3.3.2	Front Panel Buttons	3-3

Table of Contents

3.4	Field Programming	3-4
3.4.1	Introduction	3-4
3.4.2	Entering Programming Mode	3-4
3.4.3	Programming Button Functions	3-4
3.4.4	Entering and Changing the Password	3-4
3.4.5	Accessing and Modifying Parameters	3-4
3.4.6	Operating Parameter Descriptions	3-5
3.5	Setting the Volts Scale, Amps Scale, I4 Scale, Volts Mode,and Standard Frequency	3-10
3.6	Display Format	3-10
3.7	Control Relay Operation	3-11
3.8	Status Input Operation	3-12
3.9	Auxiliary Voltage Input Operation	3-12
3.10	Auxiliary Current Output Operation	3-12
4	MEASURED PARAMETERS & STATUS INFORMATION	
4.1	Introduction	4-1
4.2	Measured Parameters	4-4
4.2.1	Real Time	4-4
4.2.2	Energy	4-4
4.3	Measurement Modes	4-4
4.3.1	Demand	4-4
4.3.2	Maxima/Minima	4-5
4.3.3	Bi-Directional Energy	4-5
4.3.4	Power Reading Polarities	4-6
4.4	Status Information	4-6
5	SETPOINT SYSTEM	
5.1	Introduction	5-1
5.2	Setpoint Response Times	5-2
5.3	Trigger Parameters	5-3
5.3.1	Introduction	5-3
5.3.2	Over & Under Setpoints	5-4
5.3.3	On/Off & Counter Setpoints	5-6
5.4	Relay Control	5-6
5.5	Programming Setpoints	5-6
5.6	Power Outages	5-8
6	WAVEFORM CAPTURE	
6.1	Introduction	6-1
6.2	The Importance of Power Quality Monitoring	6-1
6.3	Using Captured Data	6-1
6.4	Triggering Via Communications	6-1

Table of Contents

7	ON-BOARD DATA LOGGING	
7.1	Introduction	7-1
7.2	Event Log	7-1
7.3	Minimum / Maximum Log	7-2
	7.3.1 Description	7-2
	7.3.2 Resetting the Min/Max Log	7-2
7.4	Snapshot Logs	7-3
	7.4.1 Introduction	7-3
	7.4.2 Preset Snapshot Log	7-3
	7.4.4 Time Interval Triggering	7-5
7.5	Access to Logged Data	7-5
8	COMMUNICATIONS	
8.1	General	8-1
8.2	RS-232 Communication	8-1
8.3	RS-485 Communication	8-2
8.4	Setting the Unit I.D. & Baud Rate	8-2
8.5	3710 ACM TRAN Model Operation	8-2
8.6	Power Measurement's SCADA System	8-2
8.7	Third-Party System Compatibility	8-3
8.8	PLC/AB Option	8-3
	8.8.1 Introduction	8-3
	8.8.2 Hardware Requirements and Wiring	8-4
	8.8.3 Communications Protocol	8-4
8.9	PLC/MOD Option	8-6
	8.9.1 Introduction	8-6
	8.9.2 Hardware Requirements and Wiring	8-6
	8.9.3 Setting Communications Parameters	8-7
	8.9.4 Communications Protocol	8-8

Appendices

A	MECHANICAL & MOUNTING DIMENSIONS	
	Basic Model	A-1
	TRAN Model	A-2
	Terminal Block Dimensions	A-3
B	SETPOINT PARAMETER FORM	
C	FIRMWARE VERSIONS	
D	TECHNICAL SPECIFICATIONS	
E	MODEL/ORDERING INFORMATION	
F	WARRANTY AND REGISTRATION	
	Warranty	F-1
	Product Return Procedure	F-1
	Registration	F-1
G	TROUBLESHOOTING	

List of Figures

1.	Introduction	
1.1.1	3710 ACM vs. 3720 ACM Feature Comparison	1-2
2.	Installation	
2.1.1	Environmental Guidelines for Installation	2-1
2.5.7a	4 Wire Wye: 3 Element Direct Connection (for 120/208 to 347/600 Volt Systems)	2-5
2.5.7b	4 Wire Wye: 3 Element Connection using 3 PTs	2-6
2.5.7c	4 Wire Wye: 2½Element Connection using 2 PTs	2-7
2.5.7d	3 Wire Wye: 3 Element Direct Connection (for 120/208 to 347/600 Volt Systems)	2-8
2.5.8a	3 Wire Delta: 2½ Element Connection using 2 PTs and 3 CTs	2-9
2.5.8b	3 Wire Delta: 2 Element Connection using 2 PTs and 2 CTs	2-10
2.5.9	3 Wire Single Phase: 2 Element Direct Connection	2-11
2.6.2	Communication Card Jumper Configuration (ISOCOM Type)	2-12
2.6.3	ISOCOM Card Terminal Block	2-13
2.6.4a	RS-232 Communications Connections	2-14
2.6.4b	RS-232 Communication Cable Wiring	2-15
2.6.5a	RS-485 Intermediate Terminal Strip Connection	2-16
2.6.5b	RS-485 Straight-Line and Loop Topologies	2-17
2.6.5c	RS-485 Topologies to Avoid	2-19
2.7.2	Form-C Control Relay Connections	2-21
2.7.3	Solid State Relay Option Connections	2-22
2.8.2a	Status Input Connections for Dry Contact Sensing - External Excitation	2-23
2.8.2b	Status Input Connections for Dry Contact Sensing - Self Excitation	2-24
2.8.3	Status Input Connections - Voltage Sensing	2-25
2.9.1	V Auxiliary Voltage Input Connections	2-26
2.10.1	I Auxiliary Current Output Connections	2-26
3.	General Operation	
3.3.1	3710 ACM Front Panel Displays	3-1
3.3.2	3710 Front Panel Features	3-2
3.4.5	Field Programming Example - Setting VOLTS SCALE	3-5
3.4.6a	Programmable Operating Parameters I	3-6
3.4.6b	Programmable Operating Parameters I	3-7
3.4.6c	Programmable Operating Parameters I	3-8
3.4.6d	Programmable Operating Parameters II	3-9

List of Figures

4.	Measured Parameters & Status Information	
4.1.1	List of Measured Parameters	4-2
4.1.2	Measurement Specifications	4-3
4.1.3	Status Information	4-3
4.3.4	3710 ACM Power Reading Polarities	4-6
5.	Setpoint System	
5.1.1	Setpoint Capabilities	5-2
5.3.1	Setpoint Trigger Parameters	5-3
5.3.2a	Over Setpoint Operation	5-4
5.3.2b	Under Setpoint Operation	5-5
5.5.1	Setpoint Parameter Form Example	5-7
6.	Waveform Capture & Waveform Recorder	
6.3.1	M-SCADA Captured Waveform Screen	6-1
6.3.2	M-SCADA Harmonic Spectrum Screen	6-2
6.3.3	M-SCADA Harmonics Table Screen	6-2
7.	On-Board Data Logging	
7.2.1	M-SCADA Event Log Screen	7-1
7.3.1	M-SCADA Preset Min/Max Log Screen	7-2
7.4.2	M-SCADA Preset Snapshot Log Screen	7-3
7.4.4	M-SCADA Historical Trending Screen	7-5
8.	Communications	
8.2.1	Remote Communication Method	8-1
8.8.2	Data Highway Single and Multi-Drop Connections	8-5
8.9.2	Modbus Single and Multi-Drop Connections	8-7

1 INTRODUCTION

Full-Featured Power Instrumentation

The 3710 ACM is a 16 bit microprocessor-based digital instrumentation package for 3-phase industrial, commercial, and utility power systems. This power monitor/meter offers high accuracy, reliability, and exceptional ruggedness. A large array of measurements, waveform capture for harmonic analysis, setpoint controlled relays, and communications capabilities make the 3710 ACM a powerful yet economical response to today’s energy management needs. It is a state of the art alternative to traditional analog electro-mechanical metering devices, replacing up to 12 individual transducers and meters.

To meet more demanding applications, POWER MEASUREMENT also offers the 3720 ACM. This companion to the 3710 ACM offers all the same capabilities while adding many new measurements and advanced features. The 3710 ACM also matches the 3720 ACM in its mounting dimensions and installation requirements, and in its straightforward and flexible user interface. Refer to Figure 1.1.1 for a comparison of features.

The 3710 ACM is based around a 12 MHz, 16 bit microcontroller chip. This provides very high computational throughput, allowing the unit’s sophisticated software to process information in real time. The unit is self-contained and its readings and setup parameters are maintained in nonvolatile memory. An internal 16-bit CPU gives the 3710 ACM the processing capability to be used as a stand-alone power monitoring and control station or as a *smart RTU* in a large energy monitoring network.

Easy Installation and Exceptional Ruggedness

The 3710 ACM is panel-mountable and provides rear-mounted, utility-approved terminal strips rated at 600V. The 3710 ACM is exceptionally rugged, with a high tolerance to electrical disturbances and temperature extremes. Many special design features guarantee performance in electrically harsh environments. The voltage, current, status (digital), relay, supply power, and communications inputs have been designed to withstand hipot, C37.90A SWC, and fast transient tests. The 3710 ACM transformer-coupled current inputs are fully isolated with respect to the chassis of the unit, and provide 300 Amp surge protection.

Inputs and Outputs Support a Wide Variety of Applications

The 3710 ACM supports a variety of power distribution configurations, including 4-wire Wye, 3-wire Delta, and Single Phase systems. 3 phase voltage and 3 phase current inputs are provided, as well as an additional current input. In installations with non-linear loads, where odd harmonics can fail to cancel, significant currents in the neutral conductor can be produced. The fourth 3710 ACM current input can be used optionally for monitoring current in the neutral conductor, or for ground current monitoring.

No intermediate transducers are required on phase voltage and current inputs. When equipped with the appropriate voltage input option, no PTs are required for Wye systems up to 347 VAC line-to-neutral / 600 VAC line-to-line. For higher voltage Wye systems, and all Delta systems, PTs can be used. The transformer-coupled current inputs accept CTs with 5 Amp full scale outputs. Up to 125% of overrange measurement is possible.

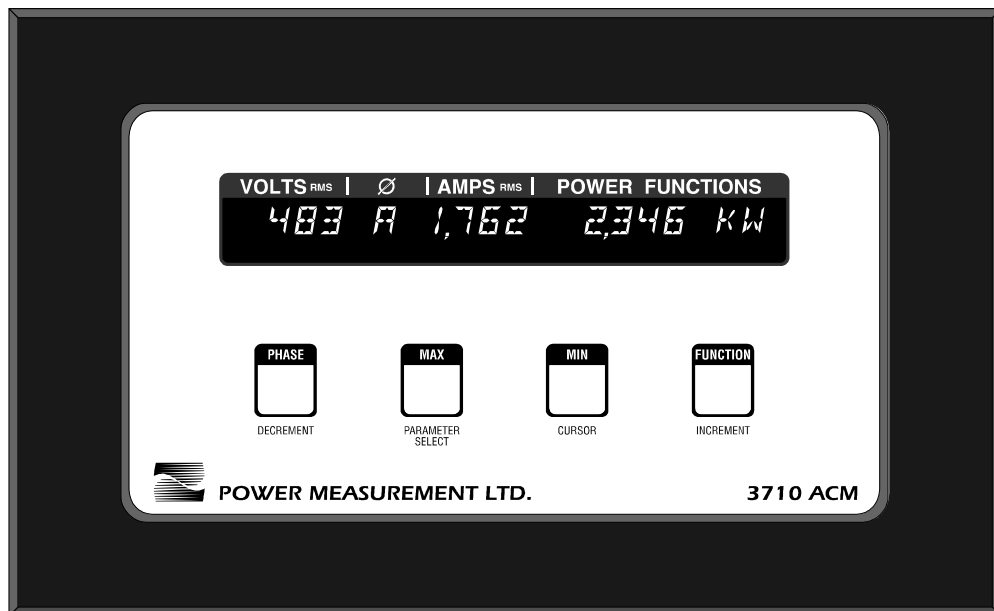

Figure 1.1.1 3710 ACM vs. 3720 ACM Feature Comparison

FEATURE COMPARISON		
	3710 ACM	3720 ACM
INPUTS & OUTPUTS	3 phase voltage inputs, 3 phase current inputs, neutral/ground current input, 3 relay outputs, 4 digital inputs with pulse counter on 1 input (maximum pulse count frequency: 0.3 Hz) 1 analog voltage input, 1 analog current output.	3 phase voltage inputs, 3 phase current inputs, neutral/ground current input, 3 relay outputs, 4 digital inputs with pulse counters on all 4 inputs (maximum pulse count frequency: 10 Hz) 1 analog voltage input, 1 analog current output.
MEASURED PARAMETERS	Over 100.	Over 300, incl. harmonic distortion and demand.
WAVEFORM CAPTURE	Yes. Triggers: comm. port.	Yes. Triggers: comm. port or setpoint.
WAVEFORM RECORDING	No.	Yes. Triggers: comm. port or setpoint.
SNAPSHOT (TREND) LOGS	Standard: 1 preset log, 12 parameters, 1200 record capacity, triggered by time interval.	Standard: 8 programmable logs, 12 parameters each, 11520 record capacity (40 days), triggered by time interval or setpoint.
EVENT LOG	Standard: 50 records. Resolution: 1 sec.	Standard: 100 records. Resolution: 1 msec.
MINIMUM / MAXIMUM LOGS	1 preset log: 17 parameters	1 preset log: over 100 parameters. 16 programmable logs: 16 parameters each with a trigger parameter for each log.
SETPOINTS	17 standard speed. Trigger event log or relay control.	17 total: 11 standard speed, 6 high speed Trigger event log, relay control, snapshot log, waveform capture, or waveform recorder.
COMMUNICATIONS	Selectable RS-232 / RS-485.	Selectable RS-232 / RS-485.

An auxiliary voltage input can be used to measure an external variable such as transformer temperature or battery voltage. Input range is 0 to 1 VAC. An auxiliary analog current output can provide 0-20 or 4-20 mA proportional to any measured parameter.

Four digital *status* inputs can be used to monitor breaker status, ground fault relay status, or any other external dry contact. The S1 input can also be used as a pulse counter to measure device cycles, running hours, etc. The basic model requires external excitation and can be used to sense the presence of voltages or contact closures. With the SES option, an internal 30 VDC supply provides self-excitation for “volts free” contact sensing.

Outputs include three on-board 10 Amp, Form-C relays that can be automatically controlled by an extensive setpoint system, or manually operated by commands made via the communications port. Relays can perform operations ranging from simple alarm activations to fully automated demand, power factor, or load control. Relays can operate in a *latched* or *pulse* mode, and can also be programmed to provide kWh, kVARH or kVAH output pulsing.

Displays and Measurements

The 3710 ACM offers more than 100 high accuracy real-time, 3-phase measured parameters, and over 20 status parameters. All measured parameters are quickly accessible from the front panel display. All measured parameters and status parameters are accessible via the meter’s communications port.

Real-time measurements include: Volts, Amps, Neutral/Ground Current, kW, kVA, kVAR, Power Factor, and Frequency. Demand values are provided for average current and total kW. Minima/maxima values are provided on all measurements. Energy values include kWh, kVAH, and kVARH. All energy readings provide bi-directional (import/export) indication. All voltage, current, power and energy readings are true RMS, including harmonics.

Status information includes real-time conditions for the three on-board relays, four status inputs, and seventeen user-programmable setpoints.

A Unique and Flexible User Interface

The 3710 ACM front panel features a large, high-visibility, 20-character vacuum fluorescent display. Volts, Amps and Power Functions can all be displayed together for the selected phase. Very large measured values with up to 9 digits of resolution (e.g. kWh) are presented using the entire display.

The 3710 ACM uses four long-life, stainless steel membrane switches to access all measured parameters and status information, and for programming functions. Phase voltage and current readings are selected using the PHASE button, while a list of common power functions is available via the FUNCTION button. The MAX and MIN buttons can be used to display the maximum and minimum value for each measured parameter.

Programming the basic setup parameters of the 3710 ACM can be performed quickly and easily from the front panel. Basic parameters include volts and amps scales, volts mode (wye, delta, etc.), baud rate, etc. Programming for some features of the 3710 ACM (data logging, etc.) must be performed via the communications port using a portable or remotely located computer running POWER MEASUREMENT'S M-SCADA, L-SCADA, or PowerView software, or any compatible third-party software. Setup and other critical information is saved when power is turned off. All programming is password protected.

A Programmable Setpoint System for Control Applications

The comprehensive on-board setpoint system of the 3710 ACM provides extensive control over the three on-board relay outputs. Seventeen user-programmable setpoints are provided. Setpoints can be activated by a wide variety of user-defined conditions, including voltage, current or power levels, and external equipment status. All setpoint activity is also recorded automatically in the on-board Event Log.

Power Quality Monitoring Capabilities

The 3710 ACM has been equipped with digital waveform sampling capabilities for power quality monitoring.

Waveform capture allows you to perform high-speed (128 samples/cycle) sampling of the eight voltage and current inputs, providing high-resolution data which can be used for detailed power quality analysis. Capture can be triggered through commands made via the meter's communications port. Sampled waveform data is stored in on-board memory and can be read via the communications port. POWER MEASUREMENT'S PC-based SCADA software can be used to upload captured waveform data, display the waveforms, and provide an indication of total harmonic distortion and a breakdown of individual harmonic components (to the 63rd harmonic) both in graphical and tabular form.

Remote communications makes power quality evaluation fast and economical. Using the SCADA system, harmonic analysis can be performed concurrently with other system supervisory functions, eliminating the need for costly manual surveys using portable instruments.

Extensive On-board Data Logging Offers Many Flexible Features

Logged data can be extremely useful in the study of growth patterns, for scheduling loads and for cost allocation, for isolating problem sources, or for analyzing a variety of power system operating conditions. The 3710 ACM supports three types of on-board data logging.

The Event Log of a standard 3710 ACM provides 50 date and time-stamped records. All events are recorded with 1 second accuracy. The log also records all relay operations, setpoint/ alarm conditions, setup changes, and self-diagnostic events.

A Min/Max Log records the extreme values for all parameters measured by the 3710 ACM, including all voltage, current, power, frequency, power factor, and demand values. Minima/maxima for each parameter are logged independently with date and time stamp, with 1 second resolution.

The 3710 ACM Snapshot Logs are *historical* or *trend* logs. The 3710 ACM offers a single Snapshot Log with 12 preset measured parameters. The Snapshot Log is triggered on a user-defined time interval basis. Time interval range is 1 second to 400 days.

Alarm conditions, events, min/max levels, and snapshot interval readings are all automatically time-stamped and logged into on-board nonvolatile memory and are accessible via the communications port. Min/max values can also be viewed via the front panel. POWER MEASUREMENT'S M-SCADA software can be used to program all log setup parameters, and to display all logged data. Historical snapshot data can be displayed graphically as a trend graph. The SCADA software will also automatically archive to disk all logged data retrieved from each remote device on a user-defined schedule basis (daily, monthly, yearly, etc.)

Remote Communications

The COMM option of the 3710 ACM provides a selectable RS-232 or RS-485 communications port which allows the 3710 ACM to be integrated within large energy monitoring networks. 3710 ACM communications uses an open protocol which allows the 3710 ACM to be easily adapted to third-party PLC, DCS, EMS, and SCADA systems.

The 3710 ACM is compatible with POWER MEASUREMENT's PC-based power monitoring software, (M-SCADA, L-SCADA, and PowerView) and entire family of 3000 series digital instrumentation, which includes power meters, power demand controllers, and smart transducer interfaces. A single M-SCADA station can support up to 99 remote sites with a total of 3168 devices. Systems are easily expandable, and very large systems can be built by linking multiple master stations. The SCADA software provides extensive full-colour data display options, automated data handling and system control features including: real-time data display for all or part of the power system; display of captured waveforms and harmonic analysis; historical trend graphing; detection, annunciation, display and logging of alarm conditions; and automatic retrieval and disk archival of data logs from remote devices.



The POWER MEASUREMENT approach to power monitoring guarantees consistently accurate data retrieval by delegating extensive data acquisition, data logging, and control capabilities to the remote meter/RTU sites. Less processing requirements at the master station means high reliability and performance. Non-volatile data logs ensure data is always retrievable following a temporary power or communication failure.

System Applications

Because of its unique measurement, storage, setpoint control (load shedding) and display characteristics the 3710 ACM should be considered for use in:

- Utility Installations
- Industrial Buildings
- Office Buildings
- Commercial Buildings
- Hospitals
- Telephone Exchanges
- Factories
- Pulp Mills
- Saw Mills
- Shopping Centres
- Large Stores
- Hotels
- Substation Metering
- Co-generation Systems
- Chemical Process Plants
- Multi-User Sites where allocation of electrical costs is desirable
- Any other installation which uses significant amounts of electrical energy
- Any other locations where remote monitoring and control is needed

2 INSTALLATION

	 DANGER
	<p>During normal operation of this device, hazardous voltages are present which can cause severe injury or death. These voltages are present on the terminal strips of the device and throughout the connected potential transformer (PT), current transformer (CT), and control power circuits. Installation and servicing should be performed only by qualified, properly trained personnel.</p>

CAUTION
<p>The 3710 ACM offers a range of hardware options that affect phase voltage, phase current, power supply, and relay input ratings. The rear panel label of the 3710 ACM lists all equipped options. Appendices D and E define all options and their associated ratings. This chapter provides detailed installation instructions applicable to each hardware option.</p>

2.1 LOCATION & MOUNTING

Environmental Conditions

The 3710 ACM should be mounted in a dry, dirt free location away from heat sources and very high electric fields. To operate properly and effectively, environmental conditions should fall within the guidelines listed in Figure 2.1.1.

Enclosure Considerations

The enclosure the 3710 ACM is mounted in (typically a switchgear cabinet) should protect the device from atmospheric contaminants such as oil, moisture, dust, and corrosive vapours, or other harmful airborne substances.

The mounting enclosure should be positioned such that the doors may be opened fully for easy access to the 3710 ACM wiring and related components to allow for convenient troubleshooting. When choosing the enclosure size, allow for extra space for all wiring, intermediate terminal strips, shorting blocks, or any other required components.

3710 ACM Mounting

The front bezel of the basic model is moulded plastic, while that of the 3710 ACM-TRAN model is a flat metal plate. Bezel dimensions differ significantly between the two models. All other dimensions are similar.

BASIC MODEL

Appendix A provides the mounting dimensions for the 3710 ACM. The basic model 3710 ACM (i.e. with display) may be panel mounted for easy access and viewing, and provides four mounting studs to facilitate this. A 5 inch depth is required behind the front panel.

WARNING
<p>Some electrical codes may prohibit extending voltages greater than 120 VAC line-to-neutral / 208 VAC line-to-line to the door of the switchgear cabinet. If this is the case, use a basic model (120 VAC input) 3710 ACM with PTs that provide 120 VAC secondaries (see Section 2.5).</p>

TRAN MODEL

The 3710 ACM TRAN model is a displayless version that can be mounted flush against any flat surface using the four mounting holes provided. The unit can also be mounted through a panel cutout originally made for a basic model 3710 ACM, if desired.

Figure 2.1.1 Environmental Guidelines for Installation

ENVIRONMENTAL CONDITION	ACCEPTABLE RANGE	
	3710 ACM	3710 ACM -XTEMP
Operating Temperature	0°C (32°F) to 50°C (122°F)	-20°C (-4°F) to +70°C (158°F)
Storage Temperature	-30°C (-22°F) to +70°C (158°F)	
Relative Humidity	5 to 95% non-condensing	

2.2 GENERAL WIRING CONSIDERATIONS

Connections to the 3710 ACM are made to two terminal strips located on the rear of the unit. Appendix A provides 3710 ACM terminal block dimensions. 12 to 14 gauge wire is recommended for all connections. Ring or spade terminals may be used to simplify connection.

CAUTION

1. All wiring must conform to any applicable local electrical codes.
2. The newest "REV B" release of the 3710 ACM power meter differs significantly from the earlier "REV A" release. Many terminal connections have been altered or modified in their position or function. Refer to the note at the beginning of this manual for more information
3. In applications where the relays are being used to perform critical equipment control operations (e.g. breaker trip, etc.), special precautions are required. See Section 2.7.

2.3 POWER SUPPLY CONNECTIONS

Power Supply Options

BASIC MODEL

The basic 3710 ACM can be powered by 85 to 132 VAC (47 to 440 Hz) or 110 to 170 VDC, both at 0.2 Amps. Power supply options are also available. The label on the rear panel indicates if the unit is equipped with one of these options.

P240 OPTION

This option is powered by 85 to 264 VAC or 110 to 340 VDC, both at 0.2 Amps.

P24/48 OPTION

This option is powered by 20 to 60 VDC at 10 Watts.

Power Sources and Connections

The basic model can be powered from a dedicated fused feed, or from the voltage source which it is monitoring, as long as it is within the supply range. The P24/48 option must be powered from a dedicated fused feed. If an AC power supply is being used, connect the line supply wire to the 3710 ACM L/+ terminal and the neutral supply wire to the N/- terminal. If a DC power supply is being used, connect the positive supply wire to the 3710 ACM L/+ terminal and the negative (ground) supply wire to the N/- terminal.

2.4 CHASSIS GROUND CONNECTION

The chassis of the 3710 ACM must be connected to earth ground. A good, low impedance chassis ground connection is essential for the 3710 ACM surge and transient protection circuitry to function effectively. It should be made to the switchgear earth ground using a dedicated 14 gauge (or larger) wire to a point where there will be no voltage error due to distribution voltage drops. Do not rely on metal door hinges as a ground path.

Ground wire connection to the chassis is made using the supplied ground lug. For the basic model, this is attached to one of the four mounting studs. For the TRAN model, the lug is attached to one of four mounting bolts. Ensure that the ground lug screw is tightened down securely onto the ground wire, and that the nut has been tightened down securely onto the lug.

CAUTION

The 3710 ACM chassis ground lug must be connected to the switchgear earth ground using a dedicated 14 gauge (or larger) wire for the noise and surge protection circuitry to function correctly. Failure to do so will void the warranty.

2.5 PHASE VOLTAGE AND PHASE CURRENT INPUT CONNECTIONS

2.5.1 PHASE VOLTAGE INPUTS

V1 Input Connection

The 3710 ACM uses the V1 input as the reference for maintaining phase relationships for all power and energy related measurements. For any system configuration, the V1 input must be connected to ensure accurate readings and the correct operation of the 3710 ACM.

Direct Connection

Whether or not potential transformers (PTs) are required depends on the nature of the system being monitored, the voltage levels to be monitored, and the input option of the 3710 ACM.

BASIC MODEL

The basic model can be used for direct connection to Wye systems up to 120 VAC line-to-neutral / 208 VAC line-to-line or Single Phase systems up to 120 VAC line-to-neutral / 240 VAC line-to-line.

277 OPTION

This option provides 277 VAC full scale inputs that can be used for direct connection to Wye systems up to 277 VAC line-to-neutral / 480 VAC line-to-line or 277 VAC line-to-neutral / 554 VAC line-to-line Single Phase systems.

347 OPTION

Models supplied with the 347 option provide 347 VAC full scale inputs that can be used for direct connection to 347 VAC line-to-neutral / 600 VAC line-to-line Wye or Single Phase systems up to 347 VAC line-to-neutral / 694 VAC line-to-line.

Using Potential Transformers

If Wye system voltages are over 347 VAC line-to-neutral / 600 VAC line-to-line or Single Phase system voltages are over 347 VAC line-to-neutral / 694 VAC line-to-line, potential transformers (PTs) are required.

NOTE

PTs are always required for Delta systems.

PTs are used to scale down the line-to-neutral voltage of a Wye or Single Phase system, or the line-to-line voltage of a Delta system to the rated input scale of the 3710 ACM. The inputs of the basic model can be used with PTs that have secondaries rated at 120 VAC or less. This can include 100/ $\sqrt{3}$, 110/ $\sqrt{3}$, 100, 110, or 120 VAC secondaries. Devices equipped with the 277 option can be used with PTs that have secondaries rated to 277 VAC, such as 220 VAC.

For proper monitoring, correct selection of PTs is critical. For Wye systems, the PT primary rating should equal the system line-to-neutral voltage or nearest higher standard size. For Delta systems, the PT primary rating should equal the system line-to-line voltage. For all system configurations, the PT secondary rating must be within the rated full scale range of the 3710 ACM voltage inputs.

PT quality directly affects system accuracy. The PTs must provide good linearity and maintain the proper phase relationship between voltage and current in order for the voltage, kW, and power factor readings to be valid. Instrument Accuracy Class 1 or better is recommended.

2.5.2 PHASE CURRENT INPUTS

The 3710 ACM uses CTs to sense the current in each phase of the power feed and (optionally) in the neutral or ground conductor. The selection of the CTs is important because it directly affects accuracy.

Current Input Options

The 3710 ACM offers various phase current input options to match the type of CTs being used and the desired overrange capability. The current input ratings of all three phase inputs and the I4 input are equivalent.

The basic model 3710 ACM is compatible with CTs with 5 Amp full scale secondaries.

The 3710 ACM provides 125% overrange capability which allows current readings to be accurately displayed up to 125% of full scale. For example, if the AMPS SCALE has been set at 2000 Amps full scale, the 3710 ACM allows for readings up to 2500 Amps.

CAUTION

Refer to the rear panel label of the 3710 ACM to determine the equipped current input option(s). Applying current levels incompatible with the current input configuration will permanently damage the device.

CT Ratings

The CT secondary should have a burden capacity greater than 3 VA.

The CT primary rating is normally selected to be equal to the current rating of the power feed protection device. However, if the peak anticipated load is much less than the rated system capacity, you can improve accuracy and resolution by selecting a lower rated CT. In this case the CT size should be the maximum expected peak current +25%, rounded up to the nearest standard CT size.



Other factors may affect CT accuracy. The length of the CT cabling should be minimized because long cabling contributes to inaccuracy. Also, the CT burden rating must exceed the combined burden of the 3710 ACM plus cabling plus any other connected devices (burden is the amount of load being fed by the CT, measured in Volt-Amps). The 3710 ACM burden rating is given in Appendix D.

Overall accuracy is dependent on the combined accuracies of the 3710 ACM, the CTs, and the PTs (if used). Instrument accuracy Class 1 or better is recommended.



2.5.3 PT & CT CONNECTION

Figures 2.5.7a to 2.5.9 illustrate all required phase voltage and phase current connections for various circuit configurations to ensure correct installation. Phasing and polarity of the AC current and voltage inputs and their relationship is critical to the correct operation of the unit.

All phase voltage sense leads should be protected by breakers or fuses at their source. In cases where PTs are required, if the power rating of the PTs is over 25 Watts the secondaries should be fused.

	 DANGER
	<p>PT secondary circuits are capable of generating lethal voltages and currents with their primary circuit energized. Standard safety precautions should be followed while performing any installation or service on the device (e.g. removing PT fuses, etc.)</p>

CTs should be connected to the device via a shorting block or test block to facilitate the safe connection and disconnection of the CTs.

	 DANGER
	<p>CT secondary circuits are capable of generating lethal voltages and currents when open circuited with their primary circuit energized. Standard safety precautions should be followed while performing any installation or service on the device (e.g. shorting CT secondaries, etc.)</p>

Refer all questions regarding proper working procedures to qualified personnel.

2.5.4 VOLTAGE REFERENCE CONNECTION

The voltage reference terminal, V_{REF} , of the 3710 ACM serves as the zero voltage reference for voltage readings. A good, low impedance V_{REF} connection is essential for accurate measurement. It should be made using a dedicated 14 gauge wire to a point where there will be no voltage error due to distribution voltage drops.

The connection point for V_{REF} is dependent on the system configuration. Each of the following configurations is illustrated in Figures 2.5.7a to 2.5.9:

- If the system being monitored is 4-wire Wye or Single Phase, V_{REF} must be connected to the neutral conductor.
- If the system is 3-wire grounded (Delta), V_{REF} must be connected to the line transformer neutral.
- For 3-wire ungrounded (Open Delta) systems, and for systems where PTs are being used, V_{REF} must be connected to the PT common leads.

2.5.5 WAVEFORM CAPTURE CONNECTIONS

The 3710 ACM waveform capture feature allows signals at each of its voltage ($V1$, $V2$, $V3$, V_{AUX}) inputs and current ($I1$, $I2$, $I3$, $I4$) inputs to be digitally sampled. The 3710 ACM uses the $V1$ input as the triggering reference for waveform capture, and to maintain phase relationships between all sampled signals. The $V1$ input must be connected for waveform capture to work. No other special wiring considerations are necessary. The operation of the waveform capture feature is described in detail in Chapter 6.

2.5.6 I4 CURRENT INPUT CONNECTIONS

The 3710 ACM is equipped with a fourth current input, named $I4$. This input is typically used to measure the current flow in the neutral or ground conductor. The use of this input is optional.

The secondary rating of the CT connected to the $I4$ input must be identical to that of the three phase current inputs. This rating depends on the current input option installed in the 3710 ACM.

The primary rating for the CT connected to the $I4$ input can be different than for the three phase inputs, since the $I4$ input scaling can be programmed independently.

2.5.7 CONNECTION FOR THREE PHASE WYE (STAR) SYSTEMS

Figures 2.5.7a to 2.5.7d provide wiring diagrams for 4 and 3-wire Wye system configurations.

For a 4-wire Wye system, the 3710 ACM senses the line-to-neutral (or ground) voltage of each phase and current of each phase, making for an equivalent 3 element metering configuration.

If the power system to be monitored is a 120 VAC line-to-neutral / 208 VAC line-to-line system, the basic model with 120 VAC inputs can be used with direct sensing of each phase, without the need for PTs. If the system is a 277 VAC line-to-neutral / 480 VAC line-to-line or 347 VAC line-to-neutral / 600 VAC line-to-line system, models with the 277 or 347 input options (respectively) may be connected directly.

The wiring diagram for these voltage ranges is shown in Figure 2.5.7a below. VOLTS MODE should be set to 4W-WYE.

Figure 2.5.7a 4 Wire Wye: 3 Element Direct Connect
(For 120 VAC line-neutral / 208 VAC line-line to 347 VAC line-neutral / 600 VAC line-line Systems)

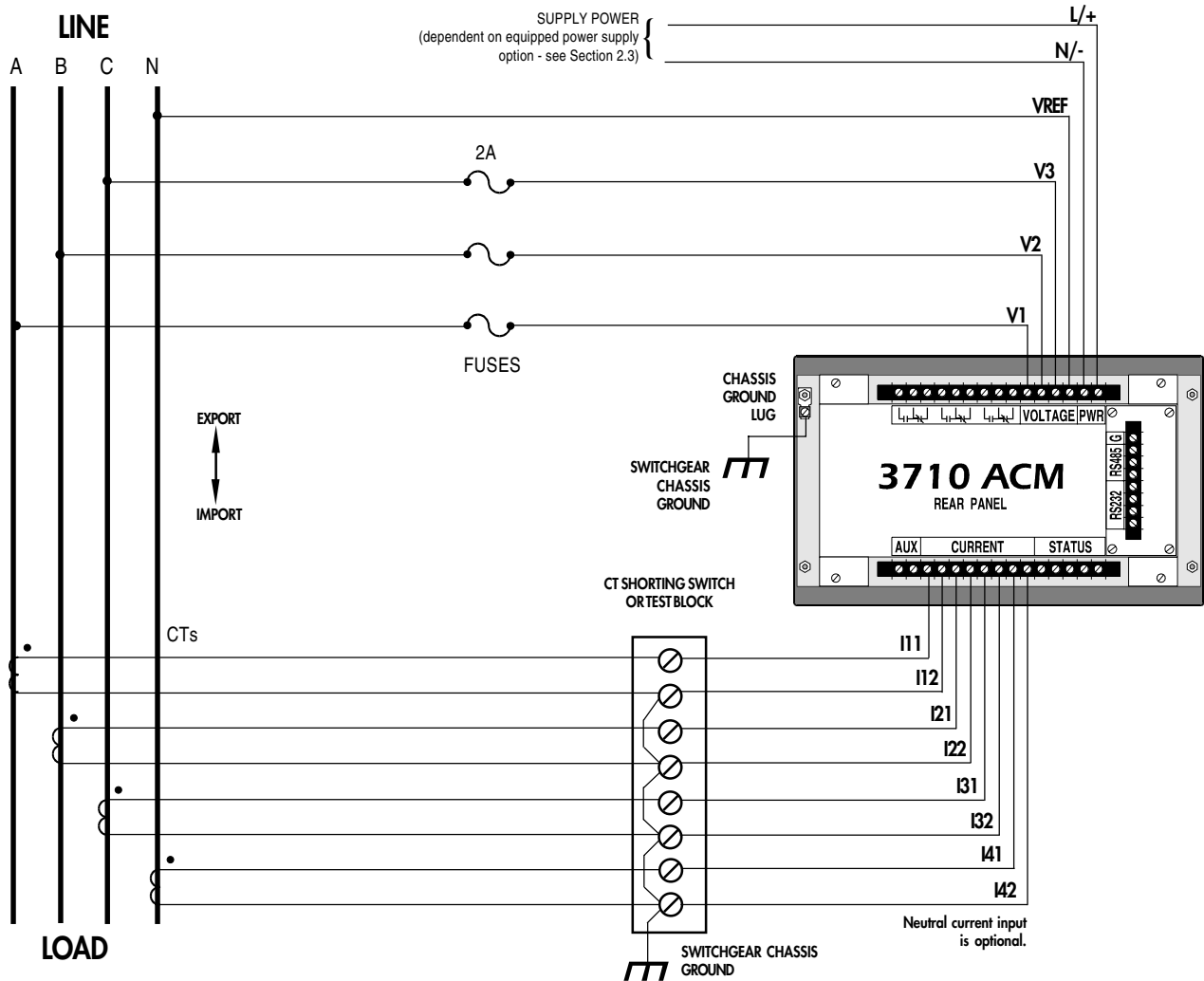

VOLTS MODE:	INPUT OPTION:	
4W-WYE	≤ 120 VAC line-to-neutral / 208 VAC line-to-line Systems:	Basic Model
	≤ 277 VAC line-to-neutral / 480 VAC line-to-line Systems:	277 Option
	≤ 347 VAC line-to-neutral / 600 VAC line-to-line Systems:	347 Option

CAUTION
Terminals and connections for "REV B" release of the 3710 ACM differ significantly from the earlier "REV A" release. Refer to Page ii at the beginning of this manual for more information.

For Wye system voltages over 347 VAC line-to-neutral / 600 VAC line-to-line, PTs must be used. When PTs are used, both the PT primary and secondary must be wired in a Wye (Star). Voltage sense leads should be protected by breakers or fuses at their source. Wiring must be exactly as shown for correct operation.

This configuration is shown in Figure 2.5.7b below. VOLTS MODE should be set to 4W-WYE.

Figure 2.5.7b 4 Wire Wye: 3 Element Connection Using 3 PTs

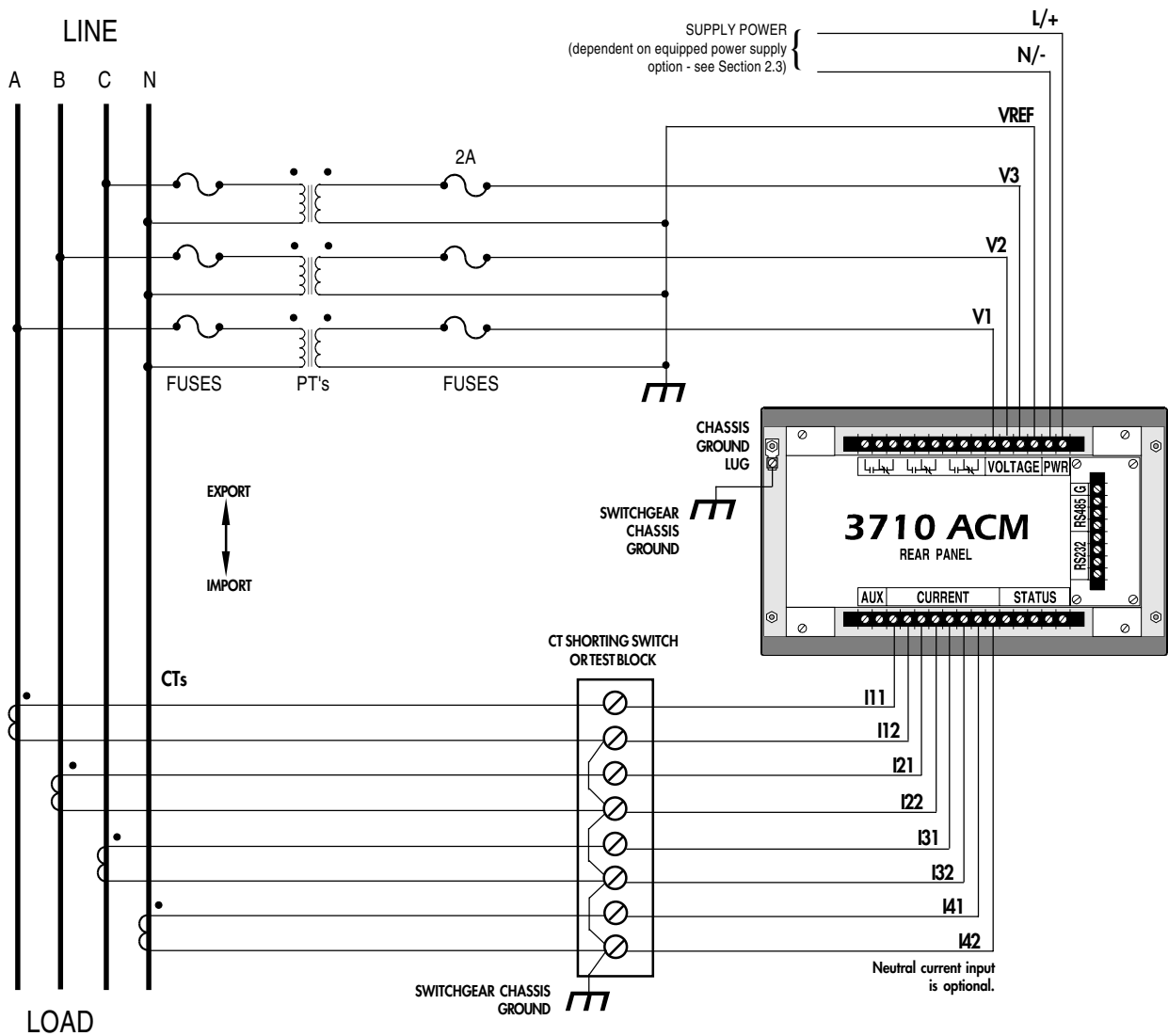

VOLTS MODE: 4W-WYE
INPUT OPTION: Basic Model (120 VAC line-to-neutral / 208 VAC line-to-line)

CAUTION
 Terminals and connections for "REV B" release of the 3710 ACM differ significantly from the earlier "REV A" release. Refer to Page ii at the beginning of this manual for more information.

The 3710 ACM also supports a 2½-element connection scheme which requires only two PTs. In this mode, the phase B voltage displayed on the front panel is derived from the available voltages.

This configuration is shown in Figure 2.5.7c. VOLTS MODE should be set to 3W-WYE.

WARNING

VOLTS MODE = 3W-WYE only provides accurate power measurement if the voltages are balanced. If the phase B voltage is not equal to the phase A and C voltages, the power readings may not meet the 3710 ACM accuracy specifications.

Figure 2.5.7c 4 Wire Wye: 2½ Element Connection Using 2 PTs

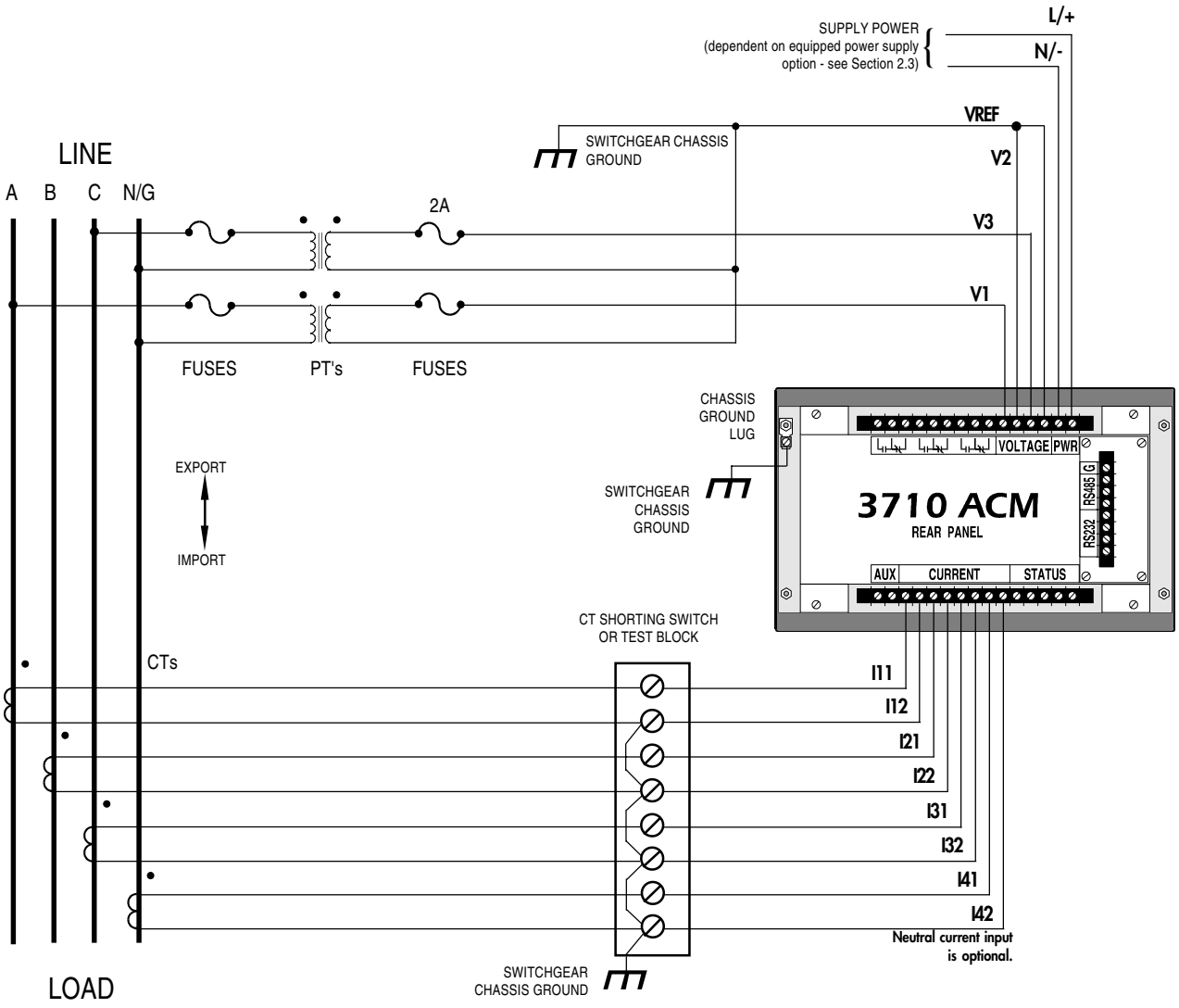

VOLTS MODE: 3W-WYE
INPUT OPTION: Basic Model (120 VAC line-to-neutral / 208 VAC line-to-line)

CAUTION

Terminals and connections for "REV B" release of the 3710 ACM differ significantly from the earlier "REV A" release. Refer to Page ii at the beginning of this manual for more information.

When the common or *star* point of a 3 wire Wye system is grounded, the 3710 ACM may be connected directly without the use of PT's (provided the voltages are within the input range of the unit).

This configuration is shown in Figure 2.5.7d. The VOLTS MODE should be set to 4W-WYE.

Figure 2.5.7d 3 Wire Grounded Wye: 3 Element Direct Connection
(For 120/208 to 347/600 Volt Systems)

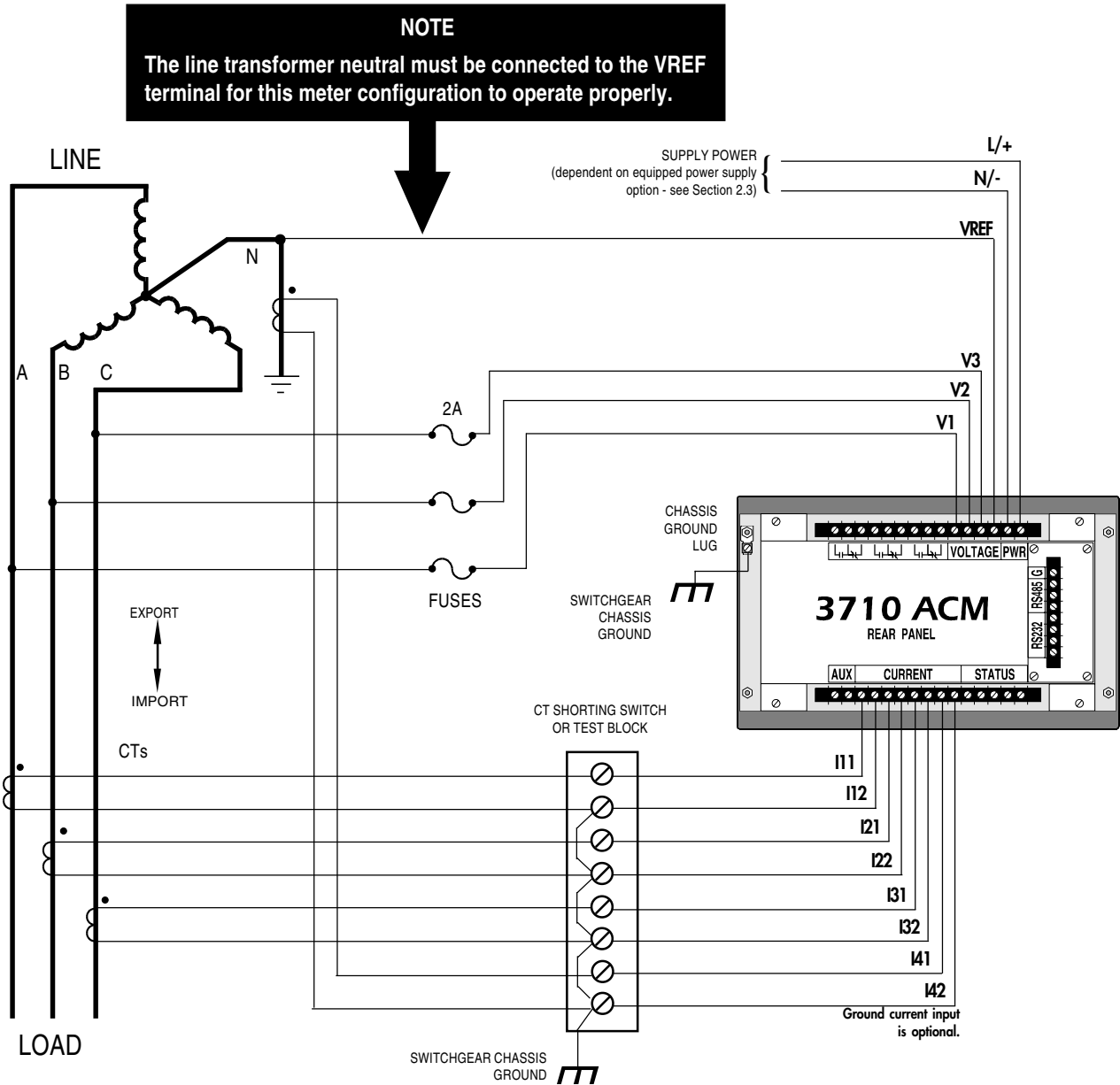

VOLTS MODE:	INPUT OPTION:	
4W-WYE	≤ 120 VAC line-to-neutral / 208 VAC line-to-line Systems:	Basic Model
	≤ 277 VAC line-to-neutral / 480 VAC line-to-line Systems:	277 Option
	≤ 347 VAC line-to-neutral / 600 VAC line-to-line Systems:	347 Option

CAUTION

Terminals and connections for "REV B" release of the 3710 ACM differ significantly from the earlier "REV A" release. Refer to Page ii at the beginning of this manual for more information.

2.5.8 CONNECTION FOR THREE PHASE DELTA SYSTEMS

For ungrounded (floating) 3 wire Delta systems, the 3710 ACM always requires PTs and senses the line-to-line voltages between each of the phases.

The 3710 ACM may be connected in either of two ways: using 2 or 3 CTs. Figure 2.5.8a below shows ungrounded Delta connection using 3 CTs. VOLTS MODE should be set to DELTA.

Figure 2.5.8a 3 Wire Delta System: 2½ Element Connection Using 2 PTs and 3 CTs

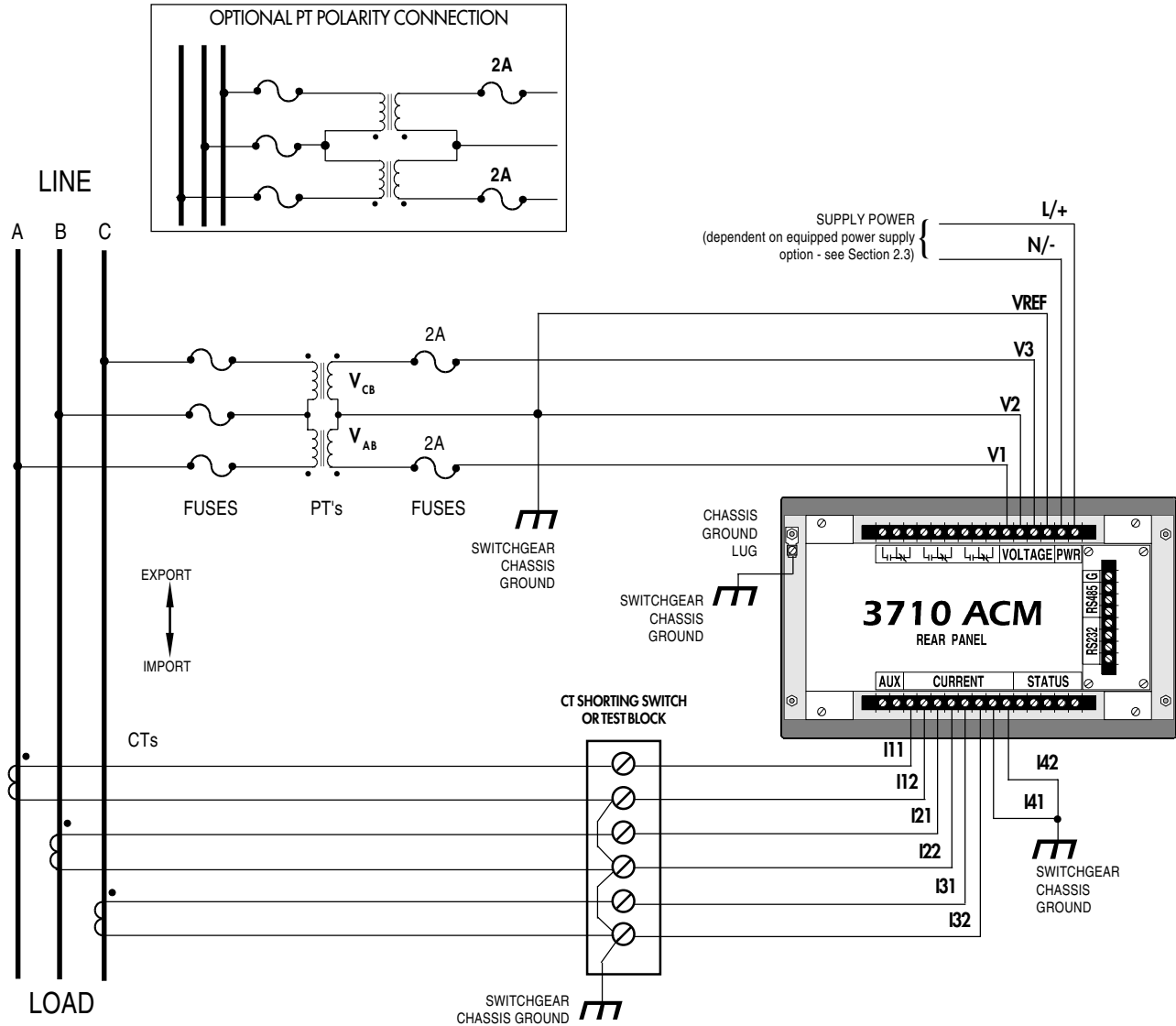

VOLTS MODE: DELTA	INPUT OPTION: Basic Model (120 VAC line-to-neutral / 208 VAC line-to-line)
-----------------------------	--

CAUTION

Terminals and connections for “REV B” release of the 3710 ACM differ significantly from the earlier “REV A” release. Refer to Page ii at the beginning of this manual for more information.

Figure 2.5.8b below shows ungrounded Delta connection using 2 CT's. VOLTS MODE should be set to DELTA.

Figure 2.5.8b 3 Wire Delta: 2 Element Connection Using 2 PTs and 2 CTs

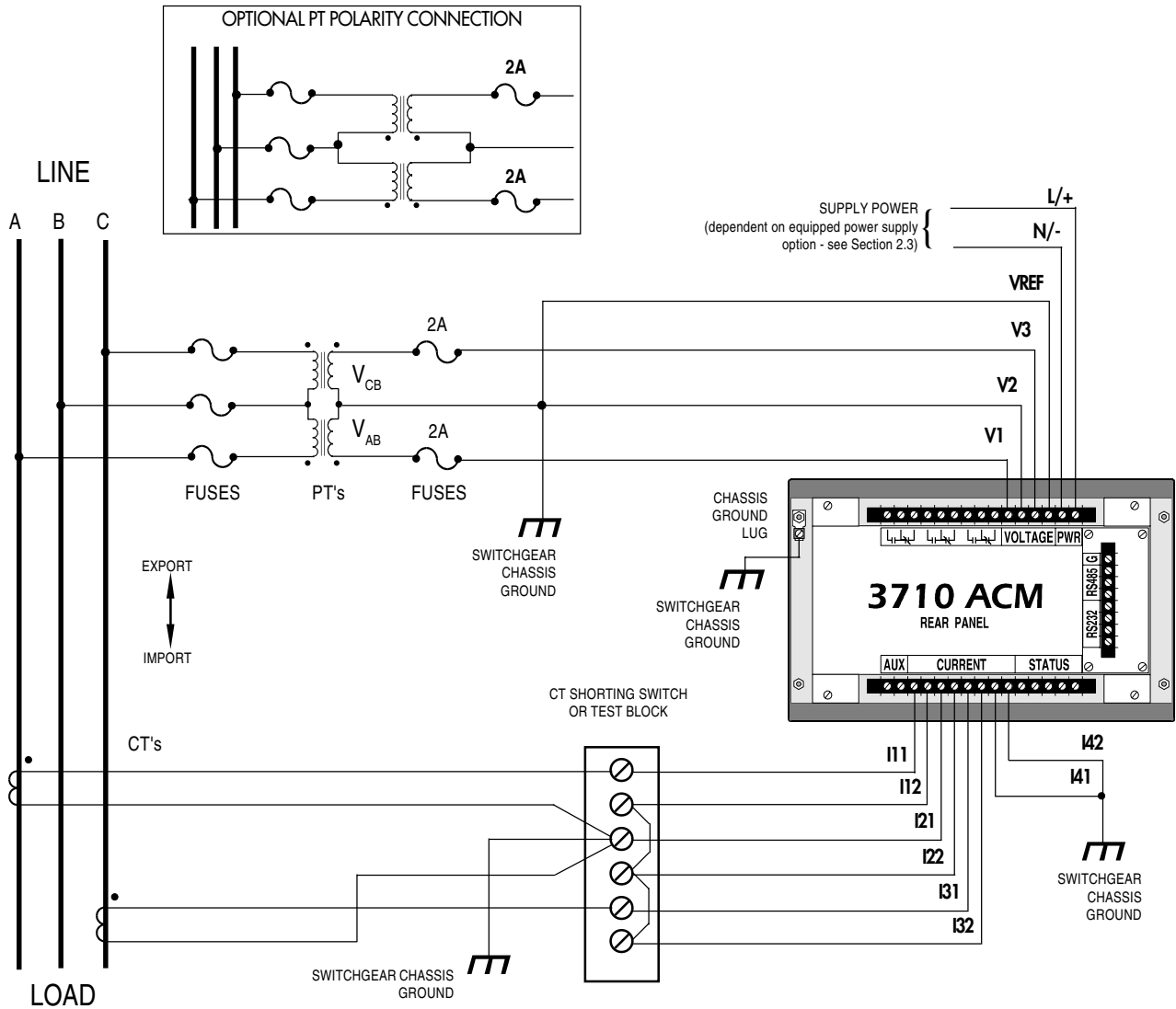

VOLTS MODE: DELTA	INPUT OPTION: Basic Model (120 VAC line-to-neutral / 208 VAC line-to-line)
-----------------------------	--

CAUTION

Terminals and connections for "REV B" release of the 3710 ACM differ significantly from the earlier "REV A" release. Refer to Page ii at the beginning of this manual for more information.

2.5.9 CONNECTION FOR SINGLE PHASE SYSTEMS

Wiring for Single Phase systems is performed by connecting the two voltage phases (each 180 degrees with respect to each other) to the V_1 and V_2 inputs of the 3710 ACM, and the outputs of the two corresponding current transformers to the I_1 input pair and I_2 input pair.

This is illustrated in Figure 2.5.9 below. Note that the V_3 input and I_3 input pair are unused and should all be grounded. For Single Phase systems, the VOLTS MODE of the 3710 ACM should be set to SINGLE.

Figure 2.5.9 3 Wire Single Phase: 2 Element Direct Connection

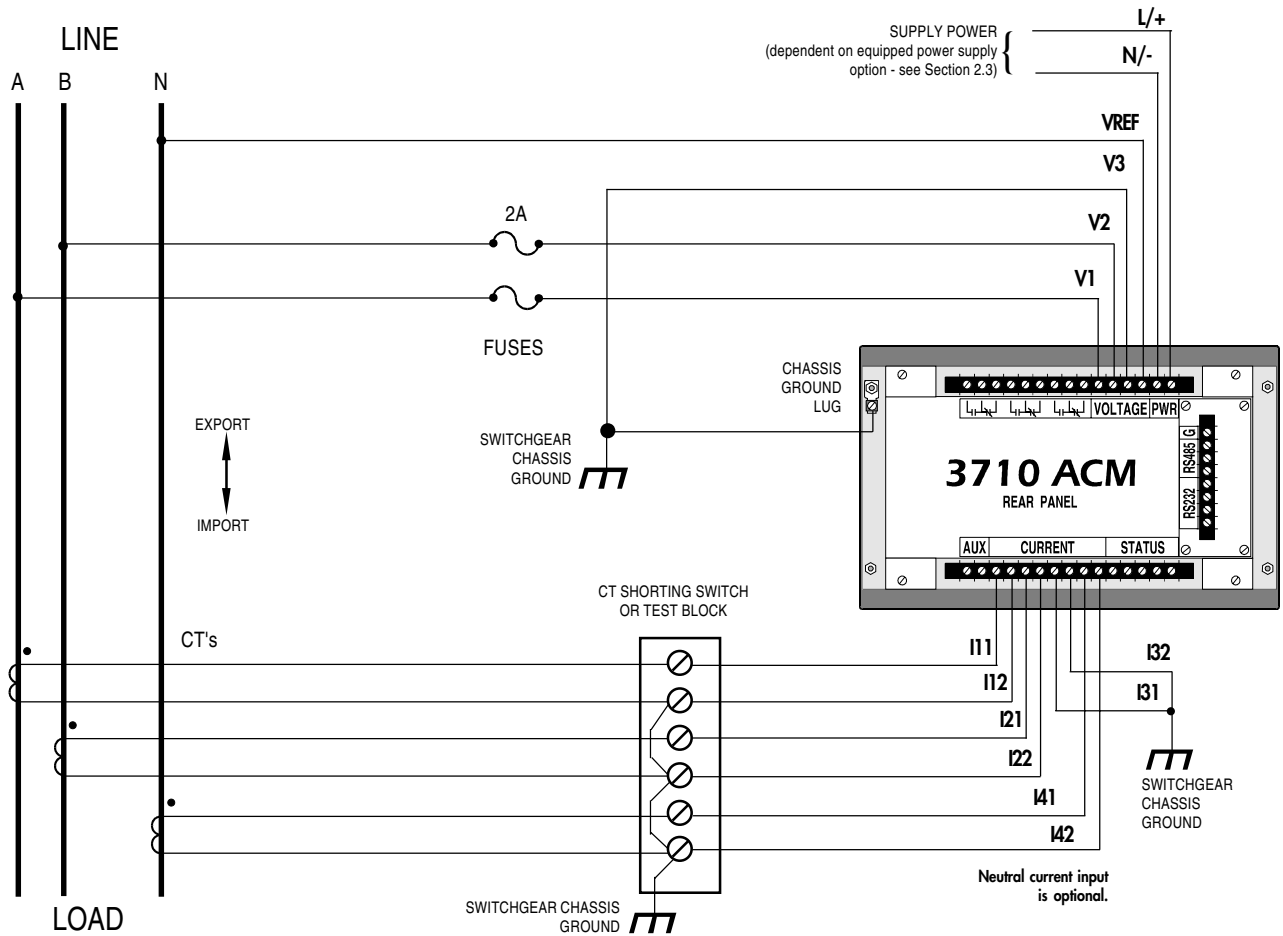

VOLTS MODE: SINGLE	INPUT OPTION:	
	≤ 120 VAC line-to-neutral / 240 VAC line-to-line Systems:	Basic Model
	≤ 277 VAC line-to-neutral / 554 VAC line-to-line Systems:	277 Option
	≤ 347 VAC line-to-neutral / 694 VAC line-to-line Systems:	347 Option

CAUTION

Terminals and connections for “REV B” release of the 3710 ACM differ significantly from the earlier “REV A” release. Refer to Page ii at the beginning of this manual for more information.

2.6 COMMUNICATIONS CONNECTIONS

2.6.1 INTRODUCTION

The COMM option of the 3710 ACM provides an ISOCOM communications card. The communications card allows the 3710 ACM to communicate using either the RS-232 or RS-485 standards. The ISOCOM provides full isolation for both RS-232 and RS-485. Optical coupling provides isolation between the communications lines and the metering equipment. Protection circuitry provides protection from common mode voltages and incorrect connection of the ISOCOM. All inputs pass the ANSI/IEEE C37-90A-1989 surge withstand and fast transient tests.

The following sections describe configuration instructions and wiring requirements for direct connection with a master computer station. Refer to Chapter 8 for information regarding communications setup parameters and remote connections made via modem.

IMPORTANT

The communications card is shipped with a label affixed to the mounting plate indicating the communications mode (RS-485 or RS-232) set at the factory. If the mode is incorrect for your application, see the following section.

2.6.2 CONFIGURATION OF THE COMMUNICATION CARD

This section explains the procedure for changing the *Comm. Mode*. The card has a jumper block allowing you to select RS-232 or RS-485 mode. The currently selected communications mode may be viewed from the front panel, if the unit is operating, (see Section 3.4 on Field Programming), or by removing the card and examining the position of the jumper block.

Removing the Card

CAUTION

An anti-static wrist grounding strap must be worn at all times while performing any reconfigurations or modifications to the 3710 ACM. Failing to do so may permanently damage the static-sensitive components inside the meter.

1. Turn off the power to the 3710 ACM.
2. Remove the four machine screws holding the rectangular communications card mounting plate to the 3710 ACM case back cover.
3. Carefully pull the plate away from the main chassis to remove the card.

Configuring the Card

The circuit board of the communications card has a jumper labelled J1. This jumper has two positions, labelled "A" and "B", which determine the communications mode. Figure 2.6.2 illustrates the jumper position required for RS-485 or RS-232 mode. Move the jumper to the correct position.

Figure 2.6.2 Communication Card Jumper Configuration (ISOCOM Type)

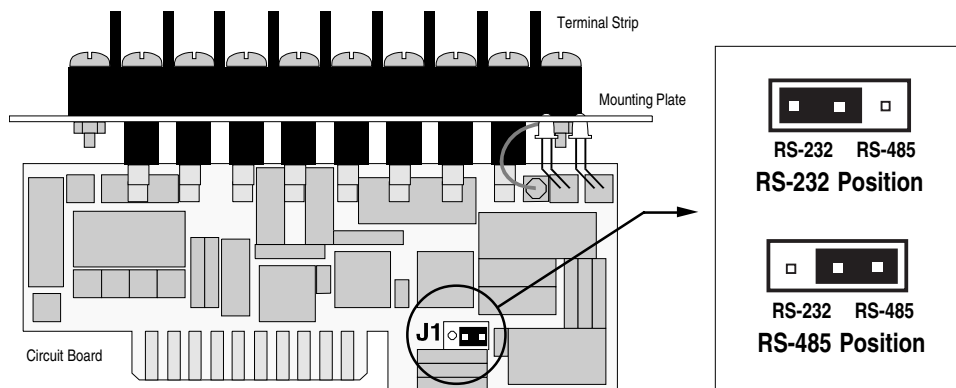

Reinstalling the Card

1. Make sure that the power to the 3710 ACM is off.
2. Insert the communications card into the communications port, ensuring that the circuit card is oriented to mate properly with the edge connector on the main board inside 3710 ACM.

NOTE

The card is polarized to ensure it can only be installed in the correct orientation.

3. Align the holes in the mounting plate of the card with the mounting holes in the meter's rear cover while lowering the card towards its seating. You should feel when the card has found the correct alignment with the edge connector.
4. Once the board is resting in proper alignment on the edge connector, carefully press down to plug the card into the edge connector.
5. Install the four mounting screws into the mounting plate to secure the card.

The card is now ready for use. Make all necessary communications connections as described above.

2.6.3 TERMINAL AND LED FUNCTIONS

The ISOCOM communications card provides a barrier-style terminal strip. Terminal functions include:

Ground	GND	Chassis Ground
RS-485	SHLD	RS-485 Shield (electrically connected to chassis ground)
	-	RS-485 Data Minus
	+	RS-485 Data Plus
RS-232	RXD	RS-232 Receive Data (i.e. data into device)
	TXD	RS-232 Transmit Data (i.e. data out of device)
	SG	RS-232 Signal Ground
	RTS	RS-232 Request To Send (optional, see Chapter 6)

Two LED indicators, TXD and RXD, show activity on the RS-485 or RS-232 communications lines and can be used to verify correct communications operation. The TXD indicator flashes when data is sent out by the device. The RXD indicator flashes when data is received by the device.

Figure 2.6.3 ISOCOM Card Terminal Block

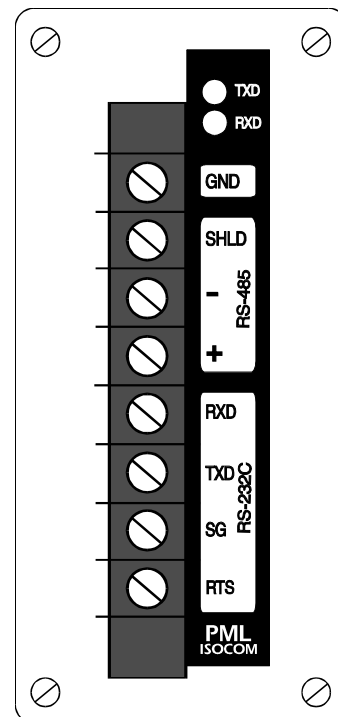

2.6.4 RS-232 CONNECTIONS

Figure 2.6.4a illustrates the wiring requirements for connecting the 3710 ACM using RS-232 communications. This can include a local direct connection to a computer or other device, or a remote connection via modem.

NOTE

For information on remote connections via modem (telephone, fibre optic, radio etc.) contact POWER MEASUREMENT for a detailed application note.

The RS-232 standard allows only a single point-to-point communications connection. Using this method, only one RS-232 equipped device may be connected to the serial port of the computer, modem, or other device.

The cable used between the computer and the modem (if used) is a standard RS-232 communications cable with a maximum length of 50 feet (15.2 m). Refer to the installation manuals for each device for cable requirements.

The cable used between the computer or modem and the 3710 ACM is a custom RS-232 cable. One end is equipped with a DB25 or DB9, male or female connector. The connector required depends on the mating computer or modem serial port connector. The other end of the cable consists of discrete wires which connect to the RS-232 terminals of the ISOCOM

card of the 3710 ACM. Cable length is 50 feet (15.2 m) maximum.

Figure 2.6.4b illustrates all RS-232 cable configurations and wiring connections.

The cable used between a computer and modem (if used) is a standard straight-through RS-232 communications cable with a maximum length of 50 feet (15.2m). Refer to the installation manuals for both the computer and modem for cable requirements.

Typically, a computer is configured as a DTE device, whereas a modem is configured as a DCE device. Note that this is not always the case; refer to computer and/or modem users manual for correct configuration.

The cables used between a DTE device and the 3710 ACM, or a DCE device and the 3710 ACM are each custom RS-232 cables. In each case, one end is equipped with a DB25 or DB9, male or female connector. The connector required depends on the mating connector of the computer or modem serial port. The other end of the cable consists of discrete wires which connect to the RS-232 terminals of the 3710 ACM. Cable length is 50 feet (15.2 m) maximum.

Figure 2.6.4a RS-232 Communications Connections

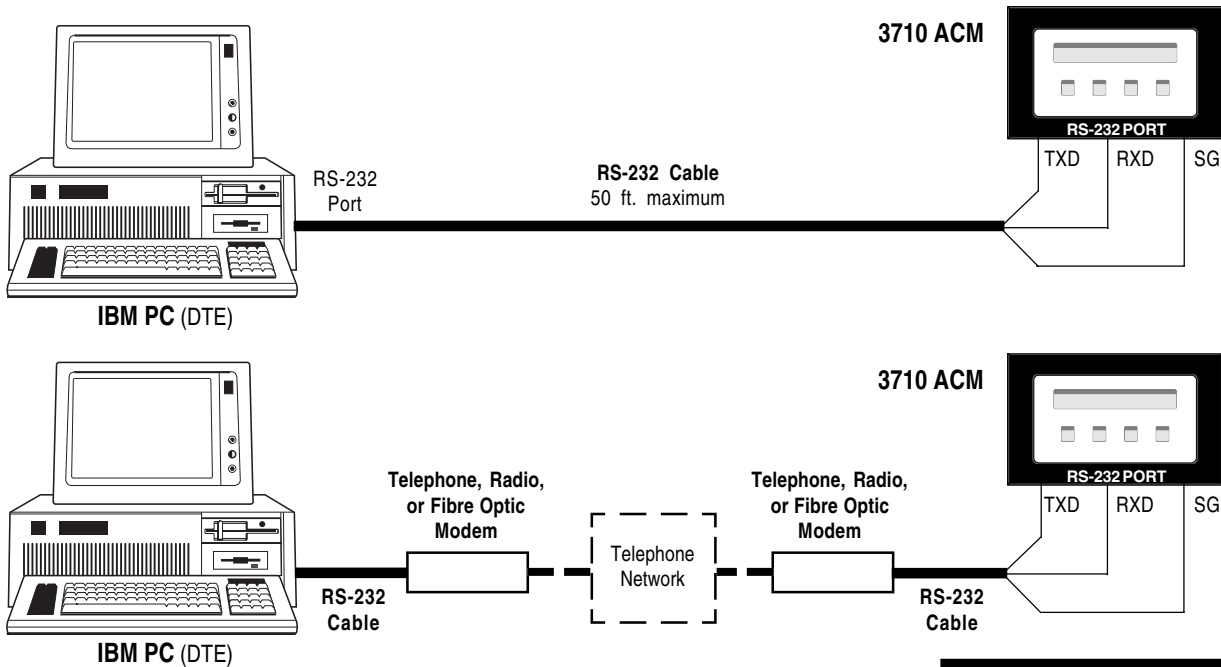

NOTE

See Figure 2.6.4b for RS-232 cable connections.

Figure 2.6.4b RS-232 Communication Cable Wiring

RS-232 CONNECTOR PINOUTS

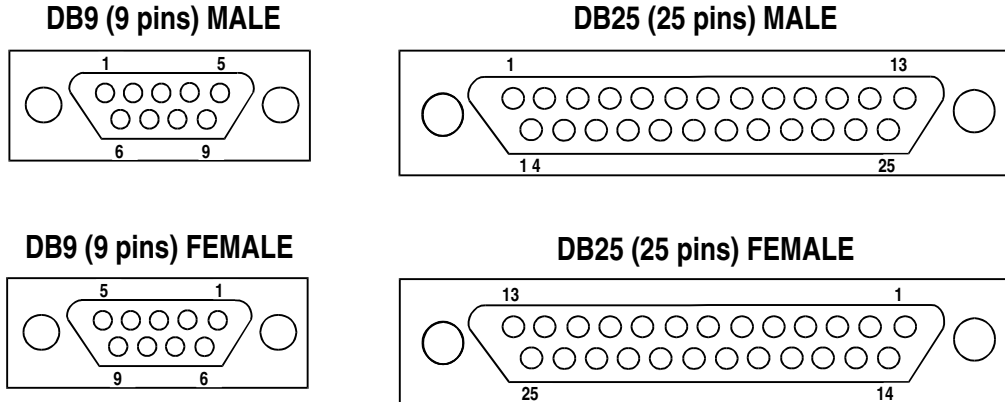

RS-232 SERIAL CABLE WIRING CONNECTIONS

DTE			3710 ACM RS-232C Port
DB9	DB25	FUNCTION	FUNCTION
3	2	Transmit (TX) →	Receive (RXD)
2	3	Receive (RX) ←	Transmit (TXD)
5	7	Signal Gnd (SG) —	Signal Gnd (SG)
7	4	Request To Send (RTS) ←	Request To Send (RTS)
8	5	Clear To Send (CTS) ←	Clear To Send (CTS)
6	6	Data Set Ready (DSR) ←	
4	20	Data Terminal Ready (DTR) ←	

Always jumper RTS to CTS at DTE end. →

Always jumper DSR to DTR at DTE end. →

DCE			3710 ACM RS-232 Port
DB9	DB25	FUNCTION	FUNCTION
2	3	Transmit (TX) →	Receive (RXD)
3	2	Receive (RX) ←	Transmit (TXD)
5	7	Signal Gnd (SG) —	Signal Gnd (SG)
7	4	Request To Send (RTS) ←	Request To Send (RTS)
6	6	Data Set Ready (DSR) ←	
4	20	Data Terminal Ready (DTR) ←	

Always jumper DSR to DTR at DCE end. →

2.6.5 RS-485 CONNECTIONS

RS-485 communications allows multiple devices to be connected on the same bus. Up to 32 devices can be connected on a single RS-485 bus, which consists of a shielded twisted pair cable. The overall length of the RS-485 cable connecting all devices cannot exceed 4000 ft. (1219 m).

To connect an RS-485 communications bus to a computer or other RS-232 equipped device, an RS-232 to RS-485 converter is required, such as POWER MEASUREMENT'S COM32 or COM128. The COM32 offers a single RS-485 port, while the COM128 offers a total of four RS-485 ports that can each support up to 32 devices.

General Bus Wiring Considerations

Devices connected on the bus, including the 3710 ACM, converter(s) and other instrumentation, must be wired as follows:

1. Use a good quality shielded twisted pair cable for each RS-485 bus. AWG 22 (0.6 mm) or larger conductor size is recommended.
2. Ensure that the polarity is correct when connecting to the RS-485 port (+) and (-) terminals of each device.
3. The shield of each segment of the RS-485 cable must be connected to ground at *one end only*.

CAUTION

Do not connect ground to the shield at both ends of a segment. Doing so allows ground loop currents to flow in the shield, inducing noise in the communications cable.

4. An intermediate terminal strip should be used to connect each device to the bus. This allows for easy removal of a device for servicing if necessary. Figure 2.6.5a illustrates the correct connections to a terminal strip. Do *not* use the T-connection illustrated. The end of this section explains in more detail the connection methods to avoid.
5. Cables should be isolated as much as possible from sources of electrical noise.

Recommended Topologies

Devices on an RS-485 bus are connected in a point-to-point configuration, with the (+) and (-) terminals of each device connected to the associated terminals on the next device. This is illustrated in Figures 2.6.5b.

While there are many topologies that can be used to connect devices on an RS-485 communication bus, the two recommended methods are the *straight-line* and *loop* topologies.

STRAIGHT-LINE TOPOLOGY

The straight-line wiring method is illustrated in Figure 2.6.5b. Note that connections are shown for one RS-485 port only. The COM128 supports four RS-485 buses simultaneously. The COM128 can exist at any position on the RS-485 bus, including an end point. Each end point of the straight-line bus must be terminated with a 1/4 watt resistor. These *termination resistors* reduce signal reflections which may corrupt data on the bus.

Termination resistors are connected between the (+) and (-) terminals of the device at each end of the bus. This device can include either a converter or any other instrument. The value of the resistor should match the line impedance of the cable being used. For AWG 22 shielded twisted pair cable, values between 150 and 300 ohms are typical. Consult the cable manufacturer's documentation for the exact impedance of your cable.

Figure 2.6.5a RS-485 Intermediate Terminal Strip Connection

CORRECT CONNECTION METHOD

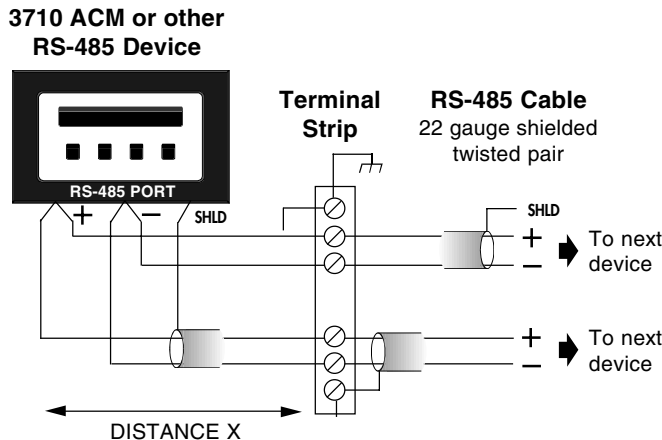

INCORRECT T-CONNECTION

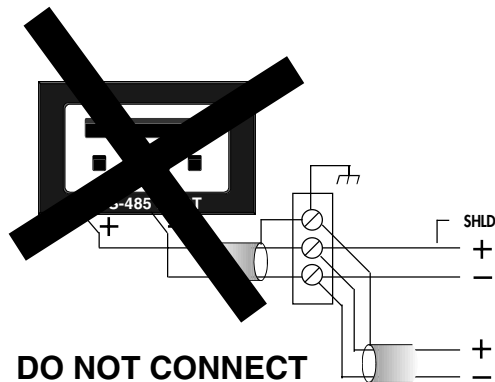
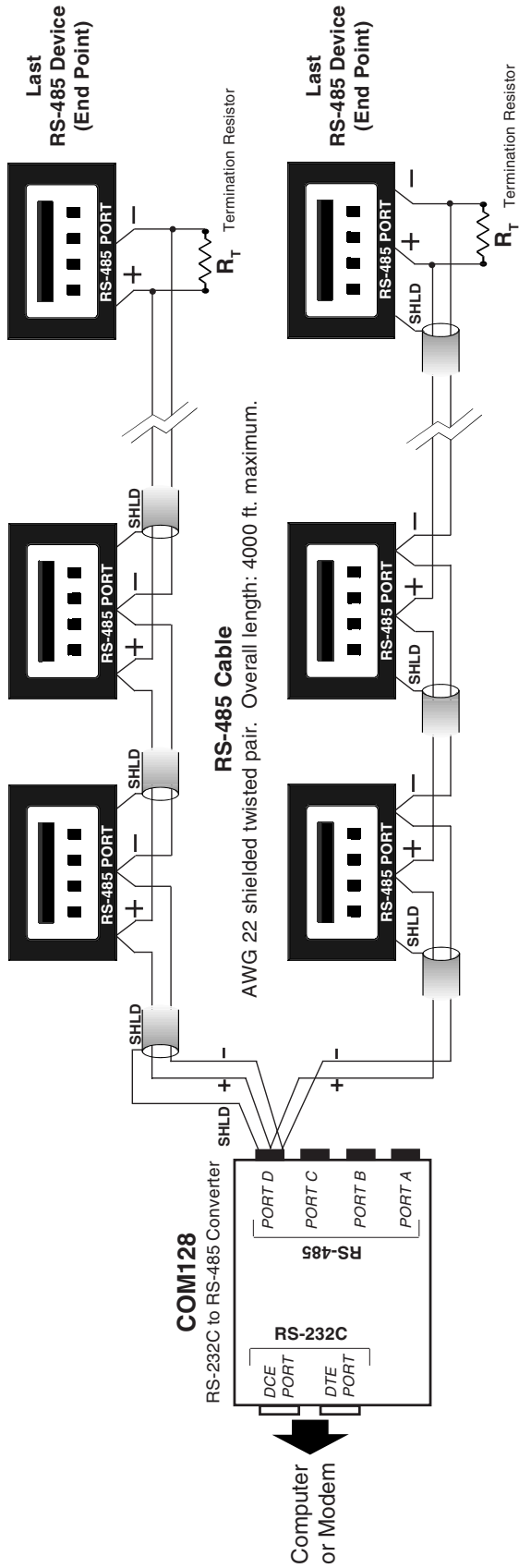
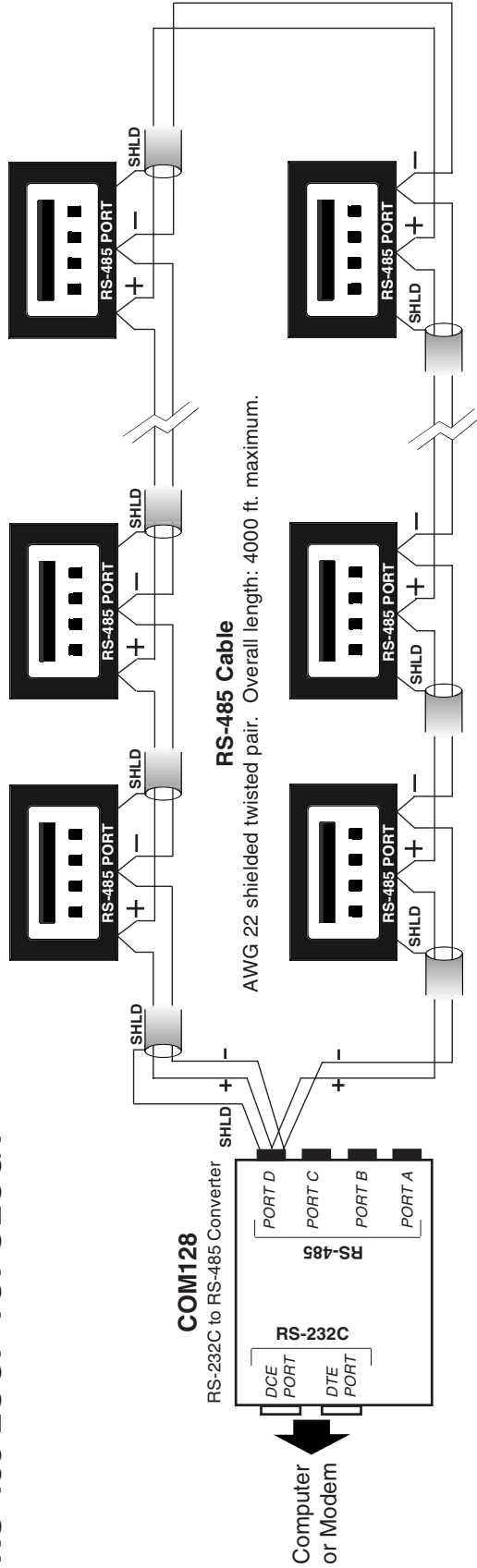

Figure 2.6.5b RS-485 Straight-Line and Loop Topologies

RS-485 STRAIGHT-LINE TOPOLOGY



RS-485 LOOP TOPOLOGY



LOOP TOPOLOGY

The loop wiring method is illustrated in Figure 2.6.5b. The COM128 can exist at any position on the RS-485 bus.

One advantage of the loop topology is that a single open circuit fault condition anywhere on the loop will not result in the loss of communication between the computer station and any of the remote devices.

The loop topology does not require termination resistors at any point on the bus.

Calculating Overall Cable Length

When determining the overall length of an RS-485 communication straight-line or loop connection, it is important to account for all cable segments. For example, when RS-485 connections to the device are made via an intermediate terminal block (Figure 2.6.5a), the lengths of cable between the device and the terminal block must be added to the total cable distance. This length is equal to 2 times distance X in the diagram.

Connection Methods to Avoid

Any device connection that causes a branch in the main RS-485 bus should be avoided. This includes *star* and *tee (T)* methods. Refer to Figure 2.6.5c for examples. These wiring methods cause signal reflections that may cause interference.

RULE OF THUMB

At any connection point on the RS-485 bus, no more than two (2) cables should be connected. This includes connection points on instruments, converters, and terminal strips. Following this guideline ensures that star and tee connections are avoided.

Figure 2.6.5c RS-485 Topologies to Avoid

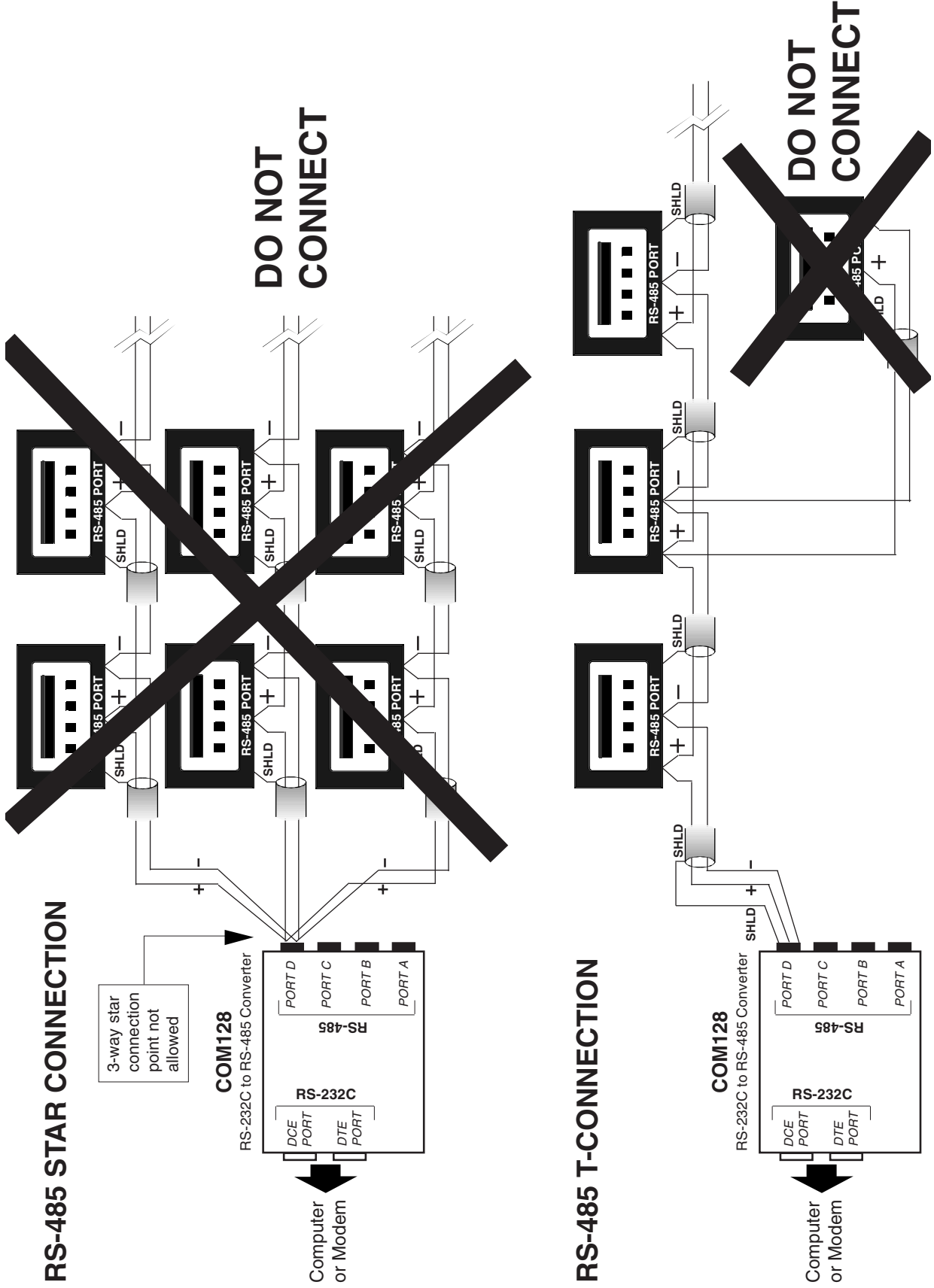

2.7 CONTROL RELAY CONNECTIONS

This section describes the wiring connection requirements and applications of the 3710 ACM on-board control relays. Section 3.7 describes the operation of the relays.



DANGER

Primary Protection

The relays of the 3710 ACM should not be used for primary protection functions. These include applications where the device will be providing:

- Overcurrent protection on circuit breakers (I^2t applications).
- Protection of people from injury. If failure of the device can cause injury or death, the 3710 ACM should not be used.
- Energy limiting. If failure of the device will cause sufficient energy to be released that a fire is likely, the 3710 ACM should not be used. In electrical systems, energy limiting is normally provided by circuit breakers or fuses.

Secondary Protection

The 3710 ACM can be used for secondary protection functions. Secondary protection includes:

- Situations where the 3710 ACM is backing up a primary protection device (shadow protection), such as an overcurrent relay.
- Situations where the 3710 ACM is protecting equipment, not people. This typically includes applications such as over/under voltage, voltage unbalance, over/under frequency, reverse power flow, or phase reversal protection, etc.



2.7.1 RELAY APPLICATION PRECAUTIONS

CAUTION

In applications where the relays are used to perform critical equipment control operations (e.g. breaker trip, etc.), the important precautions described below should be followed.

1. Connection to the external equipment should be made via an intermediate mechanism which allows relay control to be completely disabled for commissioning and servicing (see Figure 2.7.2).

NOTE

The example shown in the figure forces the normally on load on, and the normally off load off when the relays are disabled.

2. Following initial power up, the 3710 ACM should be programmed (see Chapter 3), including all required setpoints for setpoint controlled relay operations (see Chapter 5).

3. The relay outputs of the 3710 ACM should be tested to ensure that setpoint or manual control condition(s) are occurring as expected.
4. Once correct relay operation has been verified, relay control of the external equipment can be enabled.

2.7.2 FORM-C RELAYS

The basic 3710 ACM provides 3 Form-C electromechanical control relays. These relays are rated for 277 VAC or 30 VDC at 10 Amps resistive load. Figure 2.7.2 illustrates the required connections.

Figure 2.7.2 Form-C Control Relay Connections

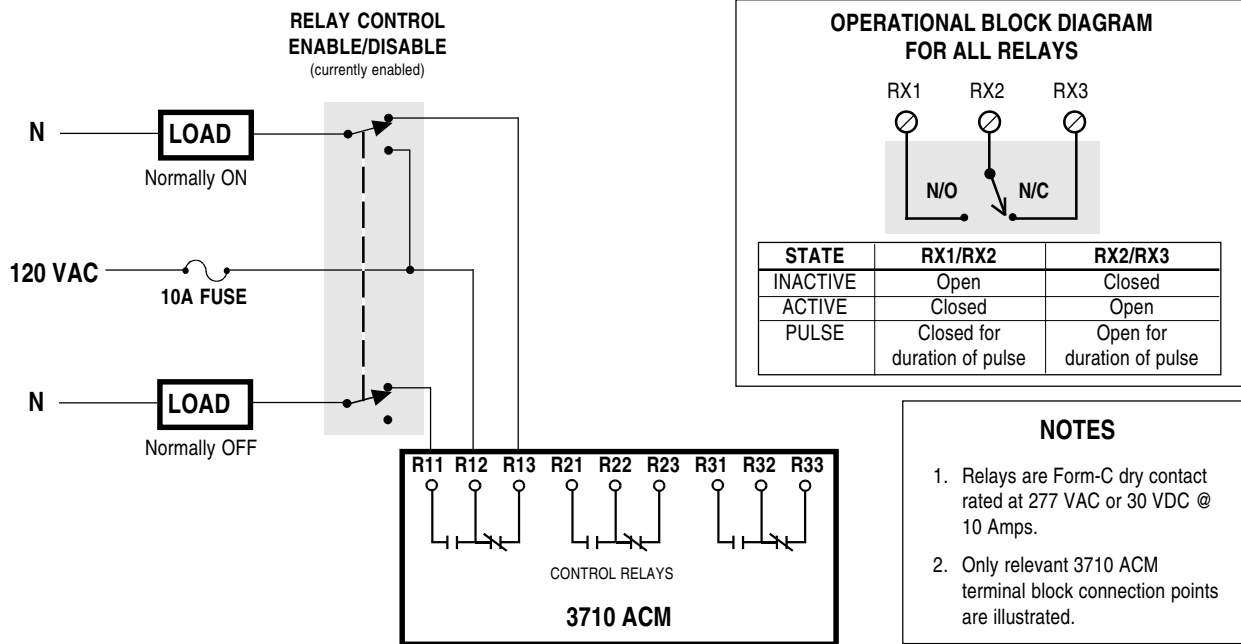

2.7.3 SOLID STATE RELAYS

The SSR option of the 3710 ACM provides three single-pole, single throw (SPST) solid state relays. These relays are rated for 24 to 280 VAC operation at 1 Amp AC resistive maximum. The relays offer significantly longer lifetimes than electromechanical relays when used for continuous pulsing applications.

Relay terminals RX2 and RX3 are used for each relay (where X = 1, 2, or 3). The RX1 terminal for each relay is left unused (no connection). See Figure 2.7.3.

IMPORTANT NOTE

USE AC VOLTAGES ONLY.

The relays are solid state and use zero-crossing turn on and off. This requires that they use AC voltages only.

Figure 2.7.3 Solid State Relay Option Connections

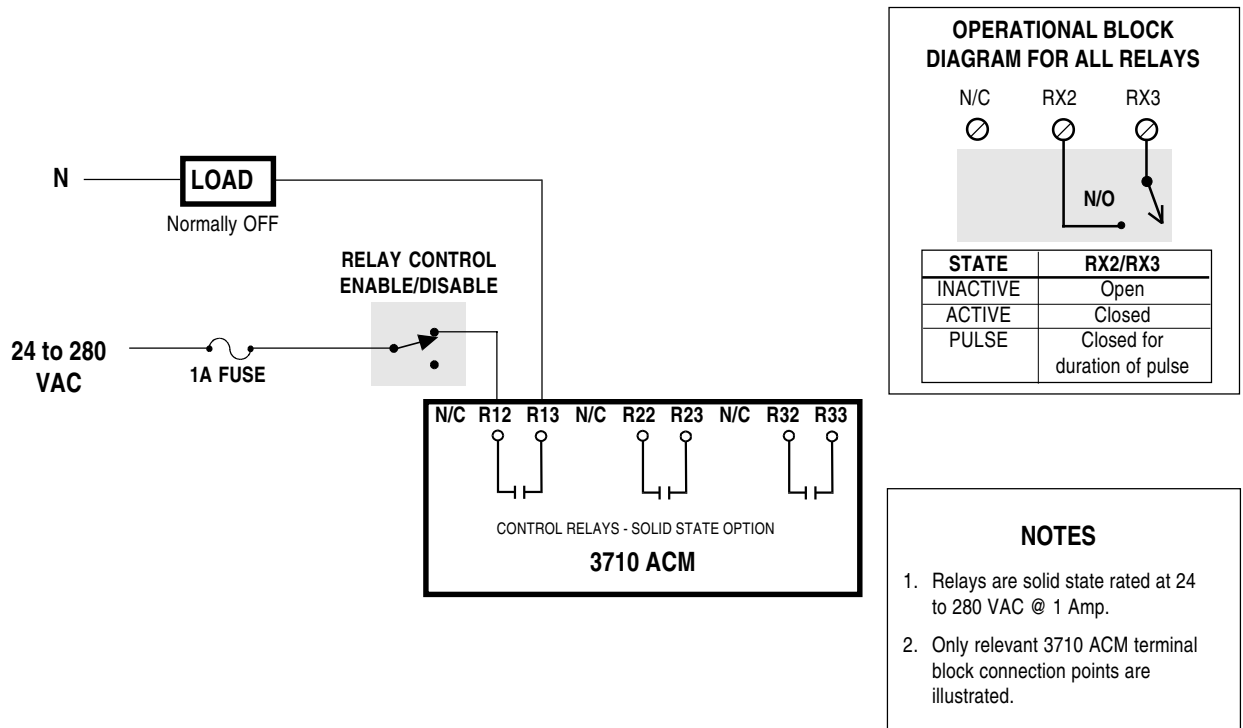

2.8 STATUS INPUT CONNECTIONS

2.8.1 INTRODUCTION

This section illustrates a number of possible wiring connection methods and applications for the status inputs. Chapter 3, Section 3.8 describes the operation of the status inputs.

The 3710 ACM uses a current sensing technique to monitor the status of an external dry contact, or the presence of an external voltage (basic model only).

SES Option

Units equipped with the SES option provide an internal 30 VDC supply for *self-excitation* of the status inputs. These units can be used for dry contact sensing applications (Section 2.8.2), but *not* for voltage sensing applications (Section 2.8.3).

2.8.2 DRY (VOLTS FREE) CONTACT SENSING

External Excitation (Basic model)

For the basic model, dry contact sensing is performed using external excitation as illustrated in Figure 2.8.2a. External excitation is provided via the SCOM terminal. A 20 to 277 VAC/VDC external power source is required. Various options include:

- an auxiliary 24 VDC power supply.
- a 24 to 277 VAC transformer with fused output.
- direct 120 VAC or 240 VAC fused power.

CAUTIONS	
1.	For this application the SCOM terminal <i>must</i> be connected to a suitable supply voltage. Do not leave the SCOM terminal floating.
2.	Up to 277 V could normally be present at the S1 to S4 terminals, depending on the external supply voltage.

When the external contact is open, there will be no current flow and the status input will register as INACTIVE. When the external contact closes, the current flow via the external supply will cause the status input to register as ACTIVE.

Figure 2.8.2a Status Input Connections for Dry Contact Sensing - External Excitation

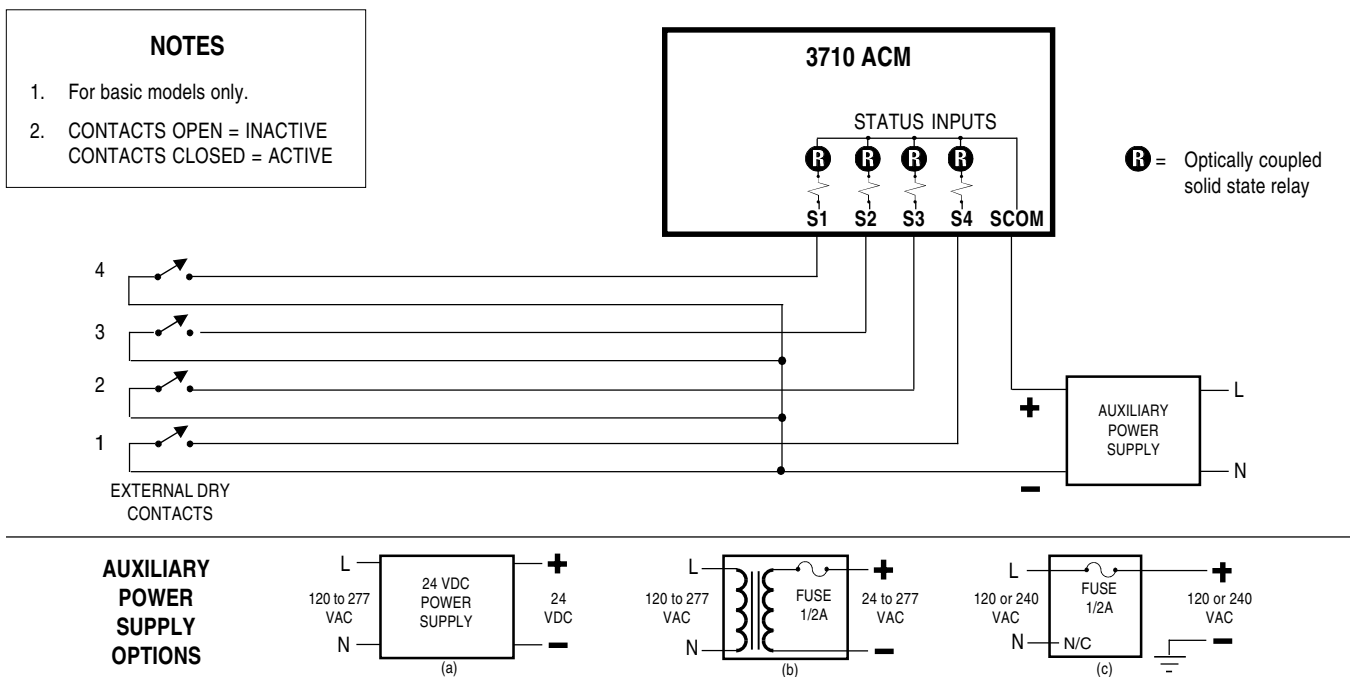

Self-Excitation (SES Option)

For models equipped with the SES option, an internal 30 VDC supply provides self-excitation of the status inputs (see Figure 2.8.2b). Note that no ground or external voltage connections are required when using this option.

CAUTION

The self-excitation configuration of models equipped with the SES option can only be used for dry contact sensing applications. Connection of an external voltage source to any of the status inputs can cause permanent damage to the 3710 ACM.

An open contact registers as INACTIVE; a closed contact registers as ACTIVE.

Figure 2.8.2b Status Input Connections for Dry Contact Sensing - Self Excitation

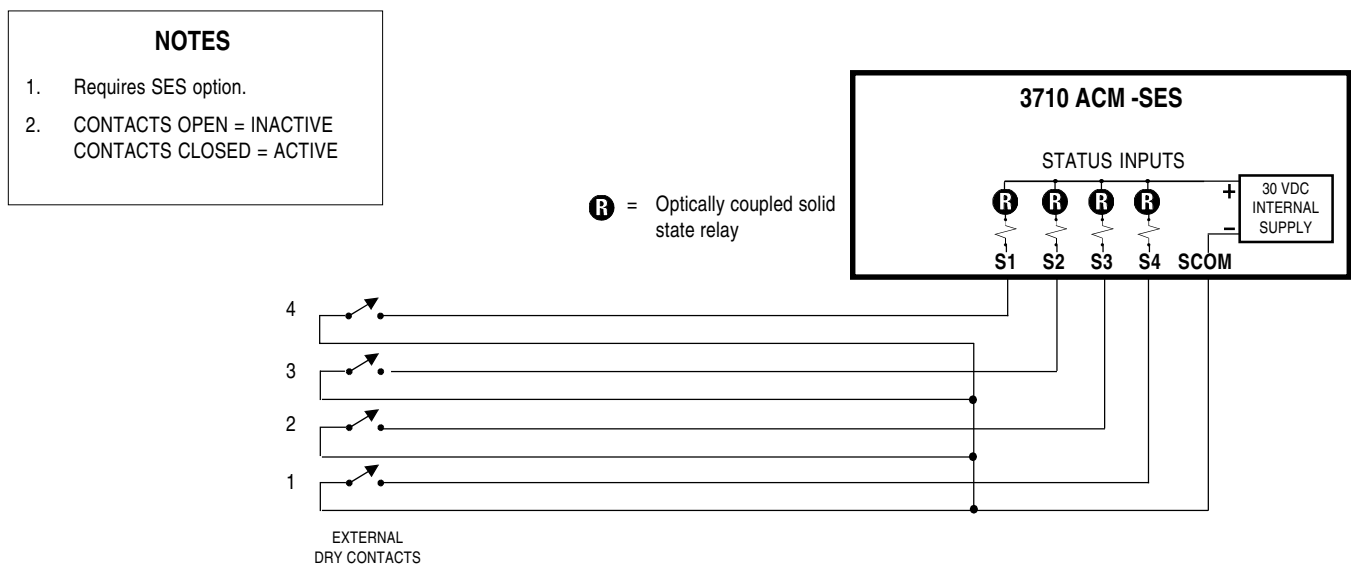

2.8.3 VOLTAGE SENSING

If the 3710 ACM is a basic model, status inputs can be used to sense the presence or absence of voltage on a power feeder. This can be used to monitor whether a piece of equipment, such as a motor, is energized (see Figure 2.8.3).

When the motor is on, there will be voltage at the sense point, and the status input will register as ACTIVE. When the motor is off, there will be no voltage at the sense point, and the status input will register as INACTIVE.

CAUTIONS	
1.	For this application the SCOM terminal must be connected to ground. Do not leave the SCOM terminal floating.
2.	Up to 277 V could normally be present at the S1 to S4 terminals, depending on the external voltage being sensed.
3.	A 3710 ACM equipped with the SES option cannot be used for voltage sensing applications. Connection of an external voltage source to any of the status inputs of a 3710 ACM -SES can cause permanent damage to the 3710 ACM.

Figure 2.8.3 Status Input Connections - Voltage Sensing

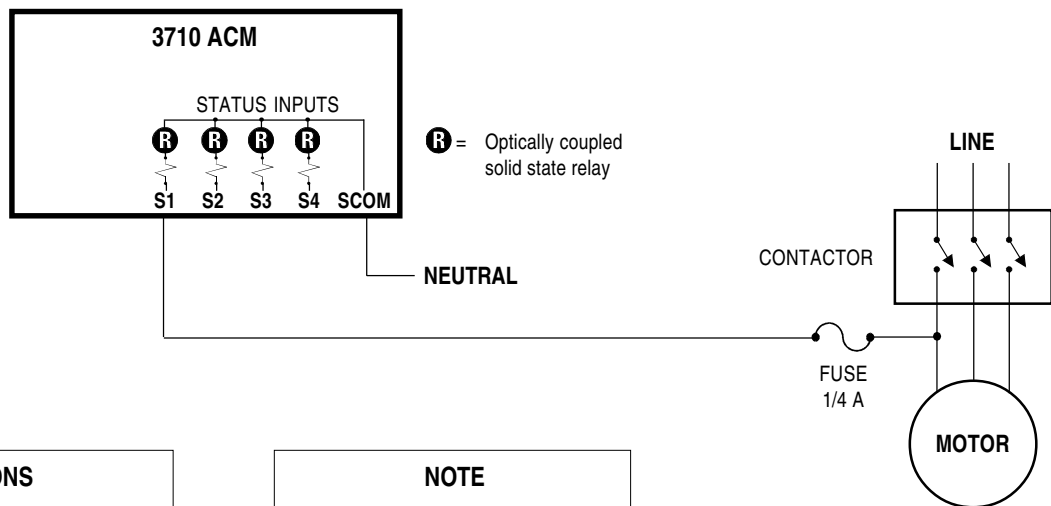

CAUTIONS	
1.	For basic models only.
2.	This arrangement should ONLY be used for 4-wire Wye systems operating at 277 VAC line-to-neutral / 480 VAC line-to-line or less.

NOTE	
MOTOR ON: Input(s) > 20 VAC or +VDC = ACTIVE	
MOTOR OFF: Input(s) < 6 VAC or +VDC = INACTIVE	

2.9 AUXILIARY VOLTAGE INPUT CONNECTIONS

Figure 2.9.1 illustrates a number of possible wiring connection methods and applications for the VAUX input. Section 3.9 describes the operation of this input.

CAUTION

VAUX is a non-isolated input. If full isolation is required, use an intermediate isolation transducer.

Figure 2.9.1 VAUX Auxiliary Voltage Input Connections

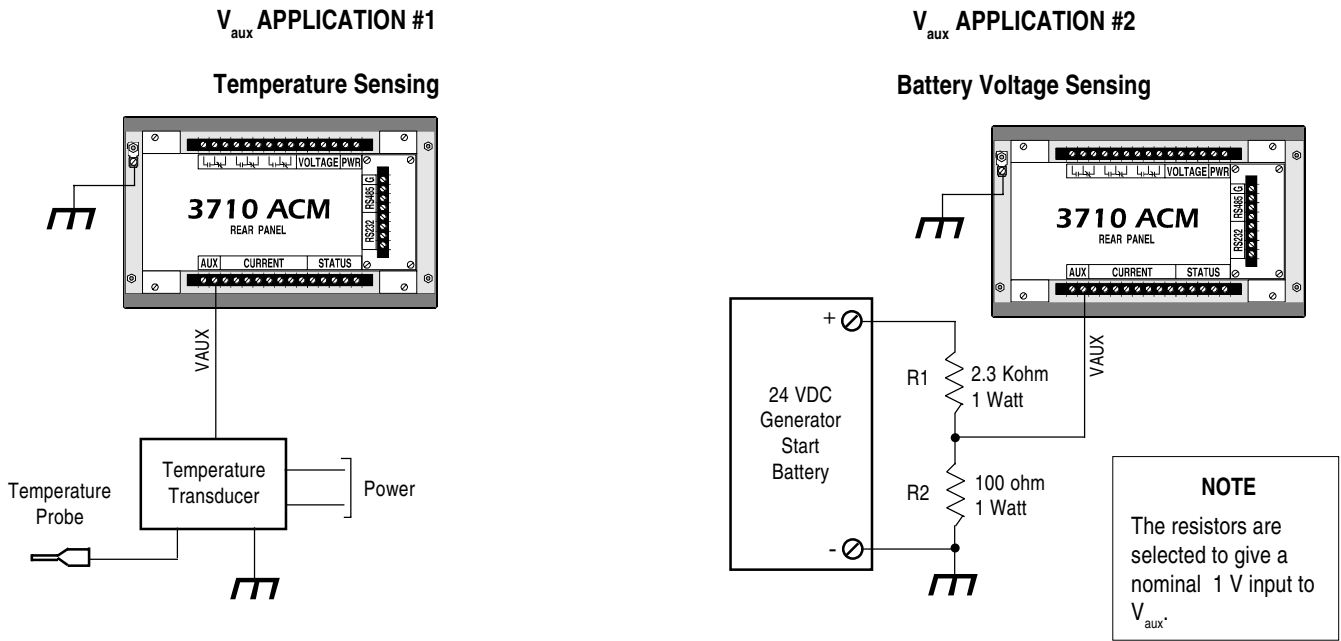
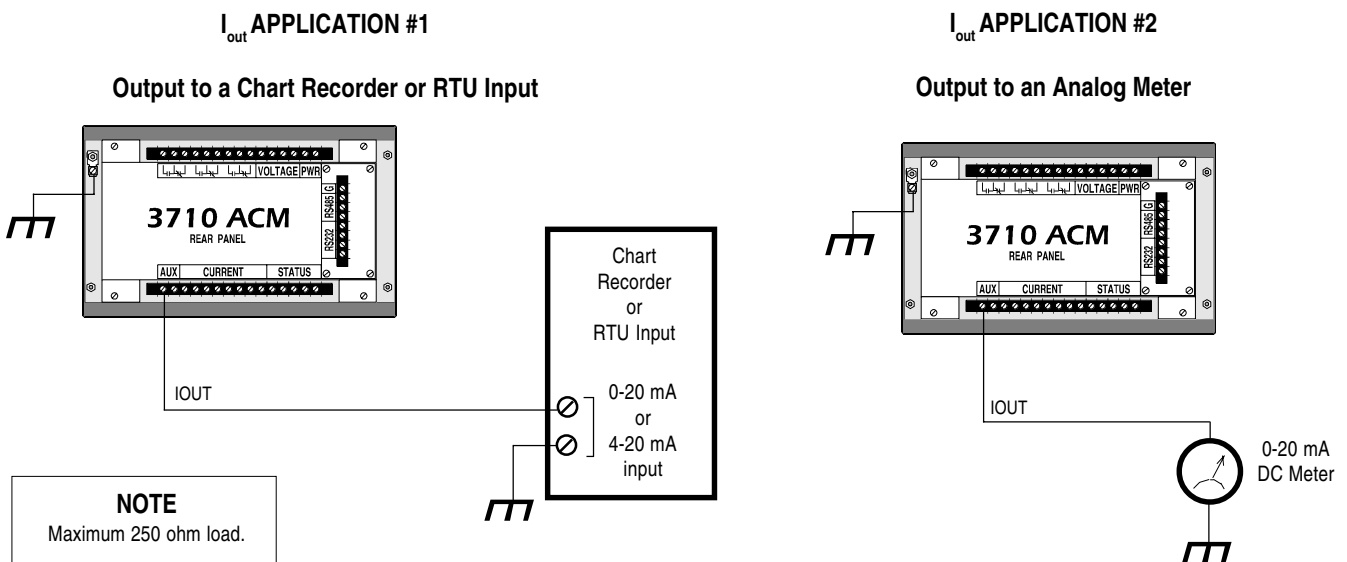

Figure 2.10.1 I_{out} Auxiliary Current Output Connections



2.10 AUXILIARY CURRENT OUTPUT CONNECTIONS

Figure 2.10.1 illustrates a number of possible wiring connection methods and applications for the IOUT output. Section 3.10 describes the operation of this output.

CAUTION
IOUT is a non-isolated input. If full isolation is required, use an intermediate isolation transducer.

2.11 MAINTENANCE

The 3710 ACM contains a battery-backed nonvolatile memory. The rated life of the battery is seventy years at 50°C (122°F), 28 years at 60°C (140°F), and 11 years at 70°C (158°F).

If the unit operates at less than 50°C for 60% of the time, less than 60°C for 90% of the time, and less than 70°C for 100% of the time, the expected battery life is 35 years. If the meter is operating in an environment where the temperatures regularly exceed 60°C, the battery should be replaced every ten years.



NOTE
When the battery is replaced, historic data will be lost. Setup parameters and calibration of the unit will not be affected.

Other than battery replacement, the 3710 ACM does not require any regular maintenance.



2.12 FIELD SERVICE CONSIDERATIONS

In the unlikely event that the 3710 ACM unit should fail, servicing requires disconnection and removal of the unit from its mounting for the purpose of repair, or for exchange with a replacement unit. The initial installation should be done in a way which makes this as convenient as possible:

1. All phase voltage sense leads should be protected by breakers or fuses at their source such that the 3710 ACM can be safely disconnected.

	 DANGER
	PT secondary circuits are capable of generating lethal voltages and currents with their primary circuit energized. Standard safety precautions should be followed while performing any installation or service on the device (e.g. removing PT fuses, etc.)

2. A CT shorting block should be provided so that the 3710 ACM current inputs can be safely disconnected without open circuiting the CT's. The shorting block should be wired so that protective relaying is not affected.

	 DANGER
	CT secondary circuits are capable of generating lethal voltages and currents when open circuited with their primary circuit energized. Standard safety precautions should be followed while performing any installation or service on the device (e.g. shorting CT secondaries, etc.)

3. All wiring should be routed to allow easy removal of the connections to the 3710 ACM terminal strips, the 3710 ACM rear cover, and the 3710 ACM itself.
4. If the control relays are used, there should be a bypass mechanism installed (see Section 2.7).

Refer all questions regarding proper working procedures to qualified personnel.

3 GENERAL OPERATION

3.1 INTRODUCTION

This chapter describes the following:

- a) Power up procedure.
- b) Front panel operation, included instructions for displaying real-time data and for performing field programming.
- c) Basic device setup procedure.
- d) Basic hardware operation, including descriptions of the relays, status inputs, and auxiliary input and output.

For a complete and detailed list of all measured parameters and status information provided by the 3710 ACM, refer to Chapter 4.

Chapters 5 to 7 describe the setup and operation of the advanced features of the 3710 ACM, including setpoint, waveform and logging functions.

Remote communications setup and operation are described in Chapter 8.

NOTE

The model 3710 ACM -TRAN provides no front panel display or keypad. Data is read, and field programming performed, via the device's communications port. Refer to Chapter 8 for instructions regarding TRAN operation. For the TRAN model, disregard all references made to front panel operations in Chapter 3.

3.2 POWER UP

After all installation wiring is complete and has been double checked, the unit may be powered up by applying the appropriate voltage to the POWER input terminals.

The 3710 ACM will first enter its *display mode*, displaying Volts, Amps, and kW averages. The values initially appearing may not be correct, since the unit has not yet been told a number of necessary pieces of information about the installation. The process of giving the 3710 ACM this information is known as *field programming*.

The 3710 ACM display mode and field programming mode are each described in detail in the following sections.

3.3 DISPLAY MODE

3.3.1 FRONT PANEL DISPLAY

Data Display and Formats

The 3710 ACM provides a unique and very flexible user interface. The front panel features a large, high-visibility, 20-character vacuum fluorescent display. The display can present a wide variety of information in many different formats. The following information and formats can be displayed:

BASIC PHASE DISPLAY

The standard front panel display (on power-up) presents VOLTS, AMPS and POWER FUNCTIONS for the selected phase (f). See Figure 3.3.1a. The PHASE button is used to advance through each phase in sequence, while a selection of power functions can be accessed using the FUNCTION button. The format of the phase labels and numeric readings can be programmed to conform to a number of different world standards. This is described in Section 3.6

FULL WIDTH DISPLAYS

Very large measured values (e.g. kW Hours) and parameters with large display labels are presented using the entire display (Figure 3.3.1b).

NOTE

Status information, including digital input and relay conditions, must be accessed via the communications port, and is not available from the 3710 ACM front panel.

Figure 3.3.1 3710 ACM Front Panel Displays

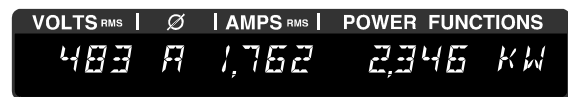

a) Standard Phase Display

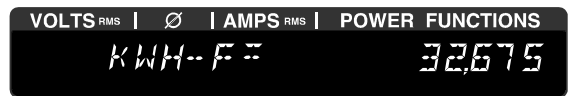

b) Full Width Display

Display Resolution

The 3710 ACM front panel can display readings with up to 9 digits of resolution. The readings for most measured parameters are displayed in integer format. Frequency readings are displayed with one decimal place of resolution.

Parameters normally presented in integer format can provide additional digits of decimal resolution by setting the associated input scale accordingly. This is discussed in Section 3.6

Display Timeout

The life and brightness of the 3710 ACM vacuum fluorescent display can be significantly extended by reducing the on time. The 3710 ACM provides a DISPLAY TIMEOUT parameter that can be used to set a timeout interval of 1 to 999 minutes, after which the display automatically shuts off. This interval starts counting down from the last button press made on the front panel. A timeout interval of 180 minutes (3 hours) or less is recommended. Setting the parameter to zero will cause the display to stay on indefinitely. While the display is turned off, pressing any button on the front panel will turn it back on again. Device programming is described in Section 3.4.

Figure 3.3.2 3710 ACM Front Panel Features

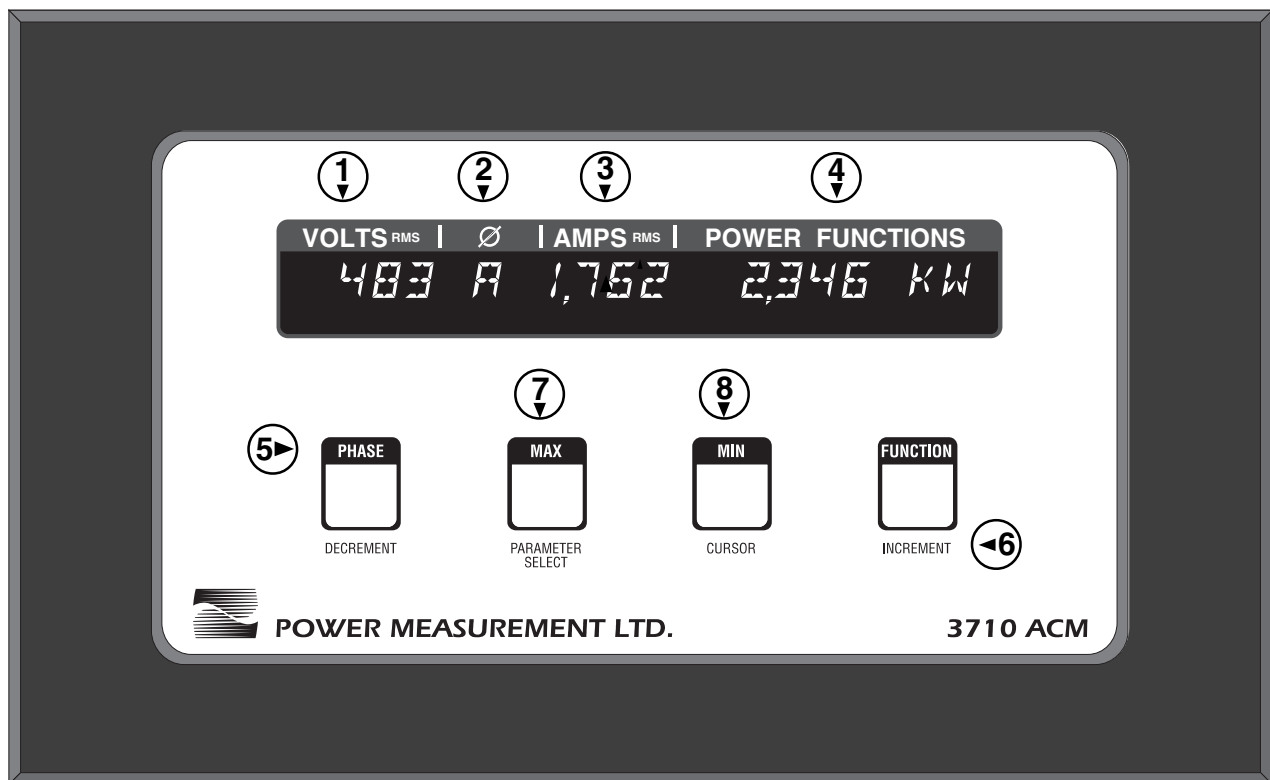

- 1. 4-digit VOLTS display
- 2. PHASE indicator
- 3. 4-digit AMPS display
- 4. 5-digit / 8-character POWER FUNCTION display

- 5. DISPLAY MODE button functions
- 6. Programming Mode button functions

7 & 8 MAX + MIN together
= enter programming mode
or return to display mode

3.3.2 FRONT PANEL BUTTONS

The 3710 ACM uses four long-life, stainless steel membrane switches for parameter selection and programming functions. (See Figure 3.3.2)

Phase Button

If the standard display is being viewed, the PHASE button will advance through each phase. The sequence of phase readings depends on the device setup, including the VOLTS MODE and PHASE ROTATION selected. Device setup is described in Section 3.4 The phase field of the front panel display indicates the phase for which readings are being displayed. The following phase labels are used:

F B C

These labels indicate line-to-neutral values are being displayed for the indicated phase.

F, B, C,

Phase indicators displayed with a comma indicate line-to-line values are being displayed for the indicated phase.

*

An asterisk symbol indicates that the average for all phases is being displayed.

The following phases of readings are available in each mode:

VOLTS MODE = 4W-WYE, 3W-WYE, OR DEMO

In each of these *Wye* modes, the PHASE button will advance through the line-to-neutral average of the three phases, the line-to-neutral values for each phase, and the line-to-line values for each phase.

VOLTS MODE = DELTA

In Delta mode, the PHASE button will increment through the line-to-line average of the three phases, and the line-to-line values for each phase.

VOLTS MODE = SINGLE

In Single Phase mode, the PHASE button steps through the sequence: A, B, L. An A indicates voltage and current for the A phase. The B indicates voltage and current for the B phase. An L indicates the line-to-line voltage, and also the average of the two line currents.

Auto Phase Cycling Mode

The 3710 ACM display can be made to automatically cycle through each phase by holding down the PHASE button for more than 2 seconds, then releasing. The display will advance through each phase (A, B, etc.) at 4 second intervals, displaying the volts and amps for each phase. Pressing any button will return the display to the regular non-cycling viewing mode.

Function Button

A preset list of useful power function parameters is available via the FUNCTION button. Pressing the FUNCTION button advances through each measured parameter.

The following is the complete sequence of power function parameters accessible using the FUNCTION button:

1. kW, total for all 3 phases
2. kVA, total for all 3 phases
3. kVAR, total for all 3 phases (kQ)
4. Power Factor, total for all 3 phases (PF)
5. Frequency, phase A (Hz)
6. kW Demand, total for all 3 phases (kWD)
7. Amp Demand, total for all 3 phases (AD) *
8. Vaux (VX)
9. I4
10. kWh Import, total for all 3 phases (kWH-F)
11. kWh Export, total for all 3 phases (kWH-R)
12. kVARH Import, total for all 3 phases (kVARH-F)
13. kVARH Export, total for all 3 phases (kVARH-R)
14. kVAH Total, (import + abs [export]) total for all 3 phases (kVAH)

* Amp Demand is replaced with kVA Demand if the unit is equipped with either the KVD or the MDK option.

A complete description of each parameter is provided in Chapter 4.

NOTES

1. If a measured imported or exported energy value is zero, it is not displayed. For example, if kWh-R=0, it will not appear in the list of power functions.
2. kWh Total and kVARH Total values (imported plus exported) are available through the communications port.

Auto Function Cycling Mode

The 3710 ACM display can automatically cycle through each power function. Hold down the FUNCTION button for more than 2 seconds, then release. The display will advance through each power function (kW, kVA, etc.) at 4 second intervals. Pressing any button will return the display to the regular non-cycling viewing mode.

3.4 FIELD PROGRAMMING

3.4.1 INTRODUCTION

Basic device programming can be performed quickly and easily from the front panel, or via the communications port using a portable or remotely located computer. Basic setup parameters include scaling factors for the voltage and current inputs, voltage mode (wye, delta, etc.), communications settings, and setpoint/relay control configuration.

Some features related to data logging functions are programmable via the communications port only. POWER MEASUREMENT's PC-based SCADA software fully supports 3710 ACM programming, providing a number of parameter screens which make setup quick and easy. The open communications protocol of the 3710 ACM also allows free access to all programming parameters using any compatible third-party system.

Setup and other critical information are saved when power is turned off. All programming is password protected.

A complete list of all programmable setup parameters is provided in Section 3.4.6.

This manual describes procedures for programming the 3710 ACM from its front panel only. For information on programming via communications using POWER MEASUREMENT's SCADA software, refer to the *SCADA Installation and Operation Manual*.

3.4.2 ENTERING PROGRAMMING MODE

To program the setup parameters of the 3710 ACM from the front panel, you must first enter *programming mode*. To enter programming mode, press the MAX and MIN buttons together. When programming mode is first entered, 'POWER MEASUREMENT' is shown on the display.

You can return to display mode at any time by again pressing the MAX and MIN buttons together.

3.4.3 PROGRAMMING BUTTON FUNCTIONS

In programming mode, the buttons of the front panel take on new programming functions. The label below each button indicates its alternate function.

- PARAMETER SELECT
Selects which parameter is displayed.
- CURSOR
Moves the cursor left one digit. The cursor position wraps around to the right of the number if advanced past the left-most digit.

- INCREMENT
Increments the digit under the cursor, advances through a number of preset values, or toggles a YES/NO option.
- DECREMENT
Decrements the digit under the cursor, advances through a number of preset values in reverse order, or toggles a YES/NO option.

3.4.4 ENTERING AND CHANGING THE PASSWORD

Pressing the PARAMETER SELECT button once advances past the 'POWER MEASUREMENT' display to the first parameter of the programming mode which is FIRMWARE. This indicates the currently installed firmware version.

The next parameter in the list is the PASSWORD. When the 3710 ACM is shipped, the password is 0. The correct password must be entered if any parameter values are to be changed. If the password is not entered, setup parameter values may still be viewed, but not modified.

To change the password, enter the present password and repeatedly press the PARAMETER SELECT button to advance past all parameters until the password parameter is displayed again. This time enter the new password. Once this has been done, returning to display mode changes the password.

3.4.5 ACCESSING AND MODIFYING PARAMETERS

Parameter Groups

To support the extensive functionality and flexibility that the 3710 ACM offers, a large number of user-programmable parameters are provided. To make field programming as efficient as possible, the setpoint and relay parameters accessible via the front panel have been organized into 2 groups.

Each parameter group provides an *access parameter*. The default setting for all group access parameters is 0 (zero). If the value is not changed, pressing the PARAMETER SELECT button skips over that parameter group. If the value is set to a non-zero number, the PARAMETER SELECT button advances through each parameter within that group. Selecting a non-zero number also selects the setpoint or relay to be programmed.

Advancing past all parameters within a group returns you to the access parameter for that group, with its value set to 0. You can then skip to the next group by pressing PARAMETER SELECT or gain access once more to the same group by setting the parameter to a non-zero number.

The entire parameter list wraps around. If a parameter group is missed, the PARAMETER SELECT button may be pressed repeatedly to return to the desired parameter or group.

Defining New Parameter Values

If the correct password was entered, you can modify any setup parameter. As discussed in Section 3.4.3, the CURSOR, INCREMENT and DECREMENT buttons can be used to change individual digits or select from a preset list of options for that parameter value. Section 3.4.6 lists all programmable parameters and their range of possible values.

Attempting to set a parameter to a value outside of its allowed range causes the display to flash the message 'INVALID ENTRY'. The message remains on the display until any button is pressed. The parameter will again be shown with its previous value.

Parameter modifications are implemented immediately when you advance to the next parameter.

Returning to Display Mode

Once all parameters have been set to their desired values, press the MAX and MIN buttons together to return to display mode.

Programming Example

Figure 3.4.5 gives a step-by-step example of how to program a 3710 ACM operating parameter from the front panel. The example given shows how to set the VOLTS MODE to DELTA the VOLTS SCALE to 277 and the AMPS SCALE to 2000.

3.4.6 OPERATING PARAMETER DESCRIPTIONS

Figures 3.4.6a to 3.4.6c provide a brief description of each operating parameter that may be programmed from the front panel. Figure 3.4.6d list all additional operating parameters which are only accessible via communications.

More detailed descriptions of each operating parameter are provided throughout this manual where operational features are described.

Figure 3.4.5 Field Programming Example - Setting VOLTS SCALE

STEP	ACTION:	DISPLAY READS:
1.	Press MAX & MIN buttons together to enter programming mode.	POWER MEASUREMENT
2.	Press PARAMETER SELECT button. Firmware version is displayed.	FIRMWARE V X.X.X.X -B
3.	Press PARAMETER SELECT button again.	PASSWORD= ****
4.	Enter password by using INCREMENT and CURSOR buttons. If password = 0 (the default), press INCREMENT button once.	PASSWORD= ***0
5.	Press PARAMETER SELECT once.	SETPOINT NUM= 00
6.	Press PARAMETER SELECT again to bypass all setpoint parameters.	RELAY OPERATION= 0
7.	Press PARAMETER SELECT again to bypass all relay parameters.	VOLTS SCALE= 1200
8.	Enter new value (277) for VOLTS SCALE. Set far right digit to 7 by pressing INCREMENT until display reads:	VOLTS SCALE= 1207
9.	Move cursor one digit left by pressing cursor button once.	VOLTS SCALE= 1207
10.	Set next digit to 7 by pressing INCREMENT until display reads:	VOLTS SCALE= 1277
11.	Move cursor 2 digits left by pressing CURSOR button twice.	VOLTS SCALE= 1277
12.	Set last digit to zero by pressing INCREMENT until display reads:	VOLTS SCALE= 0277
13.	Press PARAMETER SELECT once.	AMPS SCALE= 5000
14.	Enter new value (2000) for AMPS SCALE. Move cursor three digits left by pressing cursor button once.	VOLTS SCALE= 5000
15.	Set digit to 2 by pressing DECREMENT until display reads:	VOLTS SCALE= 2000
16.	Press PARAMETER SELECT twice to advance to VOLTS MODE.	VOLTS MODE= 4W-WYE
17.	Pressing INCREMENT once to select next mode.	VOLTS SCALE= DELTA
18.	Press MAX and MIN buttons together to return to display mode.	Volts, Phase, Amps, Function

NOTE: Cursor position in the example is shown as an underscore line. In the actual front panel display, cursor position is indicated by a blinking character.

Figure 3.4.6a Programmable Operating Parameters I

Part I: Front Panel or Communications Access

Parameter	Description	Range/Options
PROGRAMMING MODE	Initial display upon entering programming mode. Press PARAMETER SELECT to advance through each parameter.	
FIRMWARE	Indicates current version of firmware installed in unit.	n/a
PASSWORD	Correct password must be entered to allow setup parameters to be modified or clear (reset) functions to be executed. Also used to redefine password. See Section 3.4.4.	4-digit number

NOTE: In the parameter names below, xx indicates the currently selected setpoint number..

SETPOINT GROUP

SETPOINT NUM	Selects a setpoint to be programmed. Selecting 0 (default) will advance to RELAY OPERATION.	0 • 1 to 17
SPxx TYPE	Defines the type of parameter the selected setpoint is to monitor. A setting of NOT USED disables the setpoint. See Chapter 4 for setpoint type descriptions.	NOT USED • OVER VOLTS • UNDER VOLTS • VOLTAGE UNBAL • OVER CURRENT • CURRENT UNBAL • OVER kVA • OVER kW FWD • OVER kW REV • OVER kVAR FWD • OVER kVAR REV • OVER kWD • OVER AMPD • OVER FREQUENCY • UNDER FREQUENCY • OVER VAUX • UNDER VAUX • PHASE REVERSAL • UNDER PF LAG • UNDER PF LEAD • OVER I4 • S1 INPUT NORMAL • S1 INPUT ACTIVE • S2 INPUT NORMAL • S2 INPUT ACTIVE • S3 INPUT NORMAL • S3 INPUT ACTIVE • S4 INPUT NORMAL • S4 INPUT ACTIVE • SX INPUT NORMAL (any status input) • SX INPUT ACTIVE
SPxx HI LIMIT	Defines the high limit for the selected setpoint, if applicable.	0 to 999,999
SPxx LO LIMIT	Defines the low limit for the selected setpoint, if applicable.	0 to 999,999
SPxx TD OPERATE	Defines the time delay to operate (in seconds) for the selected setpoint.	0 to 32,000
SPxx TD RELEASE	Defines the time delay to release (in seconds) for the selected setpoint.	0 to 32,000
SPxx RELAY NUMBER	Selects which relay the selected setpoint controls. Value of 0 specifies no relay action.	0 • 1 • 2 • 3

Pressing PARAMETER SELECT returns to SETPOINT NUM parameter.

... continued

Figure 3.4.6b Programmable Operating Parameters I

Part I: Front Panel or Communications Access

Parameter	Description	Range/Options
RELAY GROUP		
<i>NOTE: In the parameter names below, x indicates the currently selected relay number.</i>		
RELAY OPERATION	Selects one of the three relays to be programmed. Selecting 0 (default) will advance to VOLTS SCALE.	0 • 1 • 2 • 3
Rx MODE	Defines the type of operation the selected relay is to perform. See Section 3.7	SETPOINT • kWH PULSE • kVARH PULSE • kVAH PULSE
Rx VALUE	For RX MODE = SETPOINT: Specifies latch mode or sets pulse mode duration (in seconds).	0 = latch mode 1 to 65,535 = pulse duration
Rx HRS/PULSE	For RXMODE = kWH, kVARH, or kVAH PULSE: Disables pulsing or defines number of unit-hours between pulses.	0 = disable pulsing 1 to 65,535 = unit-hours

GENERAL SETUP GROUP

NOTE: Refer to Section 3.5 for more information on setting the following 5 parameters.

VOLTS SCALE	Defines the full-scale input reading (in Volts) for the phase a, b and c voltage inputs.	0 to 999,999
-------------	--	--------------

EXAMPLES	Direct Connect (Wye)			
System Configuration:	120 VAC line-neutral/208 VAC line-line	277 VAC line-neutral/480 VAC line-line	347 VAC line-neutral/600 VAC line-line	Using PTs
Set VOLTS SCALE to:	120	277	347	PT primary rating

AMPS SCALE	Defines the full-scale input reading (in Amps) for the phase a, b and c current inputs (ct primary current rating).	0 to 30,000
VAUX SCALE	Defines the reading for a full-scale (1.000 vac) aux. voltage input. See Section 3.9.	0 to 999,999
I4 SCALE	Defines the full-scale current reading (in Amps) for the I4 (neutral/ground) input.	0 to 9,999
VOLTS MODE	Defines the power system configuration.	4W-WYE • DELTA • SINGLE • DEMO • 3W-WYE
UNIT ID	Defines the communications identification (ID) number for the 3710 ACM.	1 to 9999
BAUD RATE	Defines the baud rate.	300 • 1200 • 2400 • 4800 • 9600 • 19200
COMM MODE	View comm. mode (set by jumper block on comm. card. See Chapter 2, Sect. 2.6.2)	RS-232 • RS-485
DISPLAY TIMEOUT	Duration between last button press and display turn off.	0 (stay on), 1 to 999 (minutes)

... continued

Figure 3.4.6c Programmable Operating Parameters I

Part I: Front Panel or Communications Access

Parameter	Description	Range/Options
CLEAR MAX/MIN?	Selecting YES resets Max/Min Log when PARAMETER SELECT is pressed.	NO • YES
CLEAR HOURS?	Selecting YES resets kWh, kVARh, and kVAh counters to zero when PARAMETER SELECT is pressed.	NO • YES
DEMAND PERIOD	Defines the length of the demand period (in minutes) used in calculating all sliding window demand values. A setting of 0 specifies external synchronization mode. See Chapter 4, Section 4.3.1.	0 • 1 to 99
NUM DEMAND PERIOD	Defines the number of demand periods to be averaged in calculating all sliding window demand values.	1 to 15
PHASE ROTATION	Defines the normal phase sequence used for the phase reversal detection setpoint. See Chapter 5 for setpoint operation.	ABC • ACB
STANDARD FREQ	Defines the line frequency the 3710 ACM is to monitor (in Hertz).	50 • 60 • 400
I OUT KEY	Defines the measured parameter to which the current output will be proportional.	VOLTAGE A • VOLTAGE B • VOLTAGE C • CURRENT A • CURRENT B • CURRENT C • kW A • kW B • kW C • kVA A • kVA B • kVA C • kVAR A • kVAR B • kVAR C • VOLTAGE AV • CURRENT AV • kW TOTAL • kVA TOTAL • kVAR TOTAL • PF (total) • kW DEMAND (total) • AMP DEMAND (total) • FREQUENCY • VAUX • CURRENT I4
I OUT SCALE	Defines the reading of the associated parameter corresponding to a full-scale auxiliary current output. See Section 3.9.	0 to 999,999
I OUT RANGE	Defines the output range for the auxiliary current output.	0-20mA • 4-20mA
RTS ACTIVE LVL	Sets the active logic level asserted by the RTS line when using RS-232 communications (refer to Chapter 6). Note: This is only displayed when unit has been configured for RS-232 mode.	LOW • HIGH
FORMAT	Defines the front panel numeric and phase label formats. CURSOR selects parameter. INCREMENT or DECREMENT selects option.	Numeric formats: 1,234.5 • 1234,5 Phase label formats: ABC • XYZ • RBY • RST

Pressing PARAMETER SELECT returns to PASSWORD parameter.

Figure 3.4.6d Programmable Operating Parameters II

Part II: Communications Access Only		
Parameter	Description	Range/Options
EVENT LOG SETUP		
LOG STATUS CHANGES?	Selects whether status input events will be logged. Default is YES.	YES • NO
SNAPSHOT LOGS SETUP		
INTERVAL	Defines the time interval between snapshots if TRIGGER TYPE has been set to INTERVAL.	Days: 1 to 399, Hours: 1 to 23 Minutes: 1 to 59, Seconds: 1 to 59

3.5 SETTING THE VOLTS SCALE, AMPS SCALE, I4 SCALE, VOLTS MODE, AND STANDARD FREQUENCY

The VOLTS SCALE, AMPS SCALE, and I4 SCALE of the 3710 ACM must be set to correspond with the full scale levels being measured by the meter.

Volts Scale

For direct connection without PTs, the VOLTS SCALE is normally set to 120, 277 or 347 for 120, 227, or 347 VAC systems (respectively). If PTs are used (with a 120 VAC model), the VOLTS SCALE should be set to the primary rating of the PT. Note that this only applies if the PTs have secondaries rated at 120 VAC. If the secondaries of the PTs are not 120 VAC, the following formula should be used to determine the required VOLTS SCALE:

$$\text{VOLTS SCALE} = \frac{\text{PT Primary Rating}}{\text{PT Secondary Rating}} \times 120$$

Amps Scale (Phases A, B, and C)

The AMPS SCALE should be set to the Primary Rating of the CTs being used on the A, B, and C phases. This only applies if the CTs used are rated for a 5 Amp full scale output. If the CTs are not rated for a 5 Amp full scale output, contact the POWER MEASUREMENT factory.

NOTE

For the above parameter settings, VOLTS SCALE X AMPS SCALE should be less than 999,999,999 for correct display of kW, kVAR and kVA readings which have a maximum range of 999.999K.

I4 Scale

The 3710 ACM has a fourth current input, designated I4. This input uses connections I41 and I42 on the terminal strip. Typically, this input is used to measure current in the neutral conductor. In installations with non-linear loads, odd harmonics can fail to cancel, producing significant currents in the neutral conductor.

The ratings of this input are identical to the three phase current inputs (5 Amps nominally). The I4 SCALE parameter of the 3710 ACM specifies the scaling for the I4 input. This scaling is independent of the phase A, B, and C current inputs. This allows for a different primary rating for the CT used for the I4 input. The I4 SCALE should be set to the primary rating of the CT being used for the I4 current input. This only applies if the CT used is rated for a 5 Amp full scale output. If the CT is not rated for a 5 Amp full scale output, contact the POWER MEASUREMENT factory.

The I4 reading may be displayed from the front panel using the FUNCTION button.

NOTE

To provide greater display resolution, you can increase input scaling by an order of magnitude. For example, setting VOLTS SCALE to 1200 for a full scale input of 120V effectively provides one additional decimal place of display resolution.

Volts Mode

The VOLTS MODE should be set according to the system connection configuration (4W-WYE, 3W-WYE, DELTA, SINGLE). Refer to Section 2.5 and Figures 2.5.7a to 2.5.9 for more information.

The 3710 ACM also offers a *demonstration mode* which will generate dynamic readings for all real-time measurements based on user-programmed input scales. These readings can be viewed from the front panel or via communications. To use this feature, set VOLTS MODE to DEMO.

Standard Frequency

The STANDARD FREQ parameter should be set according to the frequency of the power signal the 3710 ACM is to be monitoring. Options include 50, 60, 400 Hz.

It is important that this parameter is set correctly, as the accuracy of the kW, kVAR, and power factor measurements can be seriously affected.

3.6 DISPLAY FORMAT

The 3710 ACM front panel display can present numeric information and phase labels in a number of different formats which reflect various world and industrial standards. A programmable parameter named FORMAT is used to define the display format.

The front panel display can present measured values using either of the two following numeric formats. The two formats are as follows:

- A comma is used for the thousands delimiter (radix), and a decimal point is used for the decimal delimiter. This is the default. Example: 1,234.5
- No thousands delimiter is used, and a comma is used for the decimal delimiter. This is the default. Example: 1234,5

There are four choices for the format of the phase labels. These are ABC (default), XYZ, RBY, and RST.

The FORMAT parameter displays both the phase label and numeric formats at once. To change either format, select the desired field using the CURSOR key. The INCREMENT or DECREMENT key can then be used to advance through each option.

3.7 CONTROL RELAY OPERATION

The 3710 ACM provides three control relays (R1 to R3). Each relay can switch AC loads of up to 277 Volts at 10 Amps and DC loads of up to 30 Volts at 10 Amps. Chapter 2 provides wiring requirements for the control relays.

The operation of each relay may be controlled in a number of different ways for various applications:

- Setpoint control on selected measured parameters, controlled by user-definable conditions. This is useful for applications such as activation of alarms or tripping of breakers for demand, power factor, or load control. Setpoint operation is described in detail in Chapter 5.
- kWh, kVARH, or kVAH pulse output.
- Manual forced control by the user through remote commands made via the communications port. This must be performed via using an IBM PC running POWER MEASUREMENT'S SCADA software, or a third-party system.

A group of programmable operating parameters has been provided which assign relay operation. The parameters allow each of the three relays to be assigned to setpoints (in *latch* or *pulse* mode), kWh pulsing, kVARH pulsing, or kVAH pulsing.

The RELAY OPERATION parameter is used to access the group of relay parameters by selecting the relay to be configured.

Setpoint Relay Operation

For setpoint operation, the relays can provide latched or pulsed operation. In latch mode, the relay will be operated (i.e. normally open contacts are closed) for the duration that the assigned setpoint is active. In pulsed mode, when the setpoint becomes active the relay will operate for a specified pulse duration.

Set RX MODE to SETPOINT for setpoint operation. Set RX VALUE to select latch mode (RX VALUE = 0), or to set the pulse duration for pulse mode operation (in seconds).

CAUTION

While you are programming the 3710 ACM from the front panel or via communications, no setpoint-controlled relay operation will occur until after you have exited programming mode. The 3710 ACM will then assess the status of each setpoint and perform any required operations.

kWH, kVARH OR kVAH Pulse Operation

When a relay is configured for kWh, kVARH or kVAH pulsing, the pulses are based on the total energy imported (forward) and exported (reverse). Set RX MODE to kWh PULSE, kVARH PULSE or kVAH PULSE. In these modes, Rx HRS/PULSE is used set the number of unit-hours between pulses.

NOTE

1. A relay configured for energy pulsing will not respond to an assigned setpoint that becomes active.
2. Maximum pulse rate for the relays is 1 pulse every 2 seconds (0.5 Hz).

Manual Forced Relay Operations

Only a setpoint relay (RX MODE = SETPOINT) may be forced operated or released using commands made via communications. Manual commands override any current setpoint condition.

If the relay is operating in *pulse* mode (RX VALUE > 0), a forced operate command will initiate a pulse of length equivalent to the value set by the RX VALUE parameter for that relay. This operation is logged in the Event Log and indicates that the relay was pulsed. A forced release command has no effect.

If the relay is operating in *latch* mode (RX VALUE = 0), it behaves normally for forced operate, forced release, and return to normal (return to setpoint control) commands.

See below for manual relay control special cases.

Relay Event Logging

For a relay assigned to setpoint operation (RX MODE = SETPOINT), the event log will log relay operations in one of two ways, depending on whether the relay has been set to operate in latch or pulse mode.

- Latch mode (RX VALUE = 0)
The Event Log records that the relay was operated (ON) when the setpoint becomes active and released (OFF) when the setpoint returns to an inactive state.
- Pulse mode (RX VALUE > 0)
The Event Log shows that the relay is pulsed when the setpoint becomes active. When the setpoint returns to its inactive state, the setpoint event is logged, but does not indicate the relay, since no pulse is generated.

If the relay is assigned to kWh, kVAH or kVAH PULSE mode, no relay operations are logged.

Manual forced relay command will be logged in the event log; however special cases exist which are described below.

Manual Relay Command Special Cases

If a manual forced operate command for a selected relay is received while that relay is currently in a forced operated state, the relay command will be ignored, and will not be logged. This also holds true for a forced release command to a relay already in a forced released state. Manual relay commands made to relays which are in a kWh, kVAH or kVAH PULSE mode will also not be logged.

3.8 STATUS INPUT OPERATION

The 3710 ACM provides four digital *status* inputs (S1 to S4) which can each be used to sense either the condition of an external dry (volts free) contact, or the presence of an external voltage (basic model only). Chapter 2 provides wiring diagrams illustrating various requirements and connection methods for the status inputs.

Both the basic model and the SES option described below require a minimum pulse width of 40 milliseconds for reliable sensing of status input changes.

Basic Model

The status inputs of a basic 3710 ACM can be used to sense external contacts or external voltages. If the input voltage is below 6 VAC or VDC, the input is sensed as *INACTIVE*. If it is over 20 VAC or VDC, it is sensed as *ACTIVE*.

SES Option

For a 3710 ACM equipped with the SES option (Self Excitation), the status inputs may only be used for external contact sensing. In this application, a contact closure is sensed as *ACTIVE*, and a contact opening is sensed as *INACTIVE*.

Pulse Counting & Demand Sync

The 3710 ACM maintains a counter for its S1 status input. The maximum frequency the counter will accurately follow is 0.3 Hz. The S1 counter can be zeroed via communications.

Status Input S4 can also be used to provide demand interval synchronization for demand measurements. Refer to Chapter 4, Section 4.3.1 for more information.

Viewing Status Input Conditions

The condition of the status inputs and S1 status input counter total can be viewed via communications only. Chapter 4 lists all available status parameters.

Logging Status Input Conditions

Status input changes can also be logged in the Event Log of the 3710 ACM which is accessible via the communications port. Logging of status input changes can be enabled or disabled via communications.

Status Input Setpoints

Status input conditions can also be used for setpoints. This allows relay control functions to be performed based on status input conditions. Refer to Chapter 5 for more information.

NOTE

The maximum pulse count for the S1 counter is 65,535 before rollover occurs.

3.9 AUXILIARY VOLTAGE INPUT OPERATION

The 3710 ACM has an auxiliary voltage input (*VAUX*) which allows an external voltage (1 VAC nominal, 1.25 VAC max.) to be measured and displayed with user-programmable scaling.

The *VAUX SCALE* parameter defines what reading will be displayed with a 1.000 VAC RMS input applied (i.e. full scale input). Range is 0 to 999,999.

EXAMPLE

A transducer is used to measure the operating temperature of a transformer's windings. The output of the transducer is connected to the *Vaux* input of the 3710 ACM. A transducer output of 1.000 VAC represents 100.0 °C.

Set *VAUX SCALE* to 100.

In this example, a transducer output of 1.000 VAC will produce a reading of 100.

NOTE

The 3710 ACM does not display *VAUX* readings with decimal places of resolution; however, additional integer digits of resolution can be obtained by setting *VAUX SCALE* to a larger value. For the example above, setting *VAUX SCALE* to 1000 provides one more digit of resolution. In this case, remember to interpret the least significant digit as one decimal place (e.g. a reading of 850 is equivalent to 85.0).

3.10 AUXILIARY CURRENT OUTPUT OPERATION

The 3710 ACM is equipped with an analog current output (*IOUT*) that may be programmed to deliver a current proportional to a measured parameter. The maximum load on the current output is 250 ohms resistive.

Three parameters must be set:

1. *IOUT SCALE*
Defines the value of the associated measured parameter corresponding to full scale current output. If *IOUT KEY* = *FREQUENCY*, *IOUT SCALE* should be set to the desired parameter value x 10 for which the current output is 20.0 mA. Range is 0 to 999,999.
2. *IOUT KEY*
Defines the measured parameter to which the current output will be proportional. Figure 3.4.6c provides a list of measured parameters that may be used.
3. *IOUT RANGE*
Defines the maximum current output range. Choices are 0-20 mA or 4-20 mA.

EXAMPLE

The IOUT current output is required to be proportional to the Phase A current reading. The maximum Phase A current expected is approximately 2000 Amps. The IOUT output is being used to provide input to a chart recorder with an input range of 4 to 20 mA.

Set IOUT KEY to CURRENT A. Set IOUT RANGE to 4 to 20 mA to match the full input range of the chart recorder. To produce the maximum chart recorder range of deflection, set IOUT SCALE to 2000.

In this example, a Phase A current reading of 0 produces 4 mA at the IOUT output (minimum scale deflection of the chart recorder). A Phase A current reading of 2000 produces an output of 20 mA (maximum scale deflection of the chart recorder).

4 MEASURED PARAMETERS & STATUS INFORMATION

4.1 INTRODUCTION

This chapter provides detailed descriptions of each measured parameter and all status information provided by the 3710 ACM. These are categorized as follows:

1. *Measured Parameters:*
 - a) Real-time
 - b) Energy
2. *Measurement Modes:*
 - a) Demand
 - b) Minima & Maxima
 - c) Bi-directional Energy
3. *Status Information:*
 - a) Status (digital) input conditions
 - b) Status input S1 counter total
 - c) Control relay output conditions
 - d) Setpoint conditions

Figure 4.1.1 provides a complete listing of all measured parameters, including their associated display labels. Figure 4.1.2 lists measurement accuracies, display resolutions, and range of readings. Figure 4.1.3 lists all status information.

The following sections of this chapter provide additional information on each parameter type.

Measured Parameter Display Labels

The large number of measured parameter types and their associated measurement mode combinations requires that the 3710 ACM display parameter names on its front panel using special formats. Labels for each measurement, phase, input, and mode are listed in Figure 4.1.1. As mentioned in Chapter 3, parameter names which require a large number of characters are presented using the entire display.

Access to Parameters

All measurements, measurement modes, and status parameters listed in Figures 4.1.1 and 4.1.2 are *continuously* monitored or calculated internally by the 3710 ACM. As described in Chapter 3, you can access a large number of parameters directly from the front panel using the default PHASE, FUNCTION, MAX and MIN button displays.

The *complete* selection of measured parameters and status information is always accessible via remote communications (Chapter 8).

Figure 4.1.1 List of Measured Parameters

TYPE	DESCRIPTION	MEASUREMENT										MEASUREMENT MODES					
		Name			Phase or Input			S.W. Demand	Min / Max		Bi-directional Energy						
		A	B	C	A	B	C		Avg.	Total	I4	Vaux	Minimum	Maximum	Imported	Exported	Total
Voltage	Voltage line-to-neutral.	N/L	A	B	C	*				VX		N/L	N/L				
	Voltage line-to-line.	N/L	A,	B,	C,	*						N/L	N/L				
Current	Current.	N/L	A	B	C	*			I4		AD *	N/L	N/L				
Power	Real power.	kW	C/O	C/O	C/O			N/L			KWD	N/L	N/L				
	Reactive power.	kQ	C/O	C/O	C/O			N/L				N/L	N/L				
	Apparent power.	kVA	C/O	C/O	C/O			N/L				N/L	N/L				
Energy	Real energy.	kWH						N/L						kWH-F	kWH-R	C/O	C/O
	Reactive energy.	kVARH						N/L						kVARH-F	kVARH-R	C/O	C/O
	Apparent energy.	kVAH						N/L								kVAH	
Power Factor	Power Factor.	Lagging	PFLG	C/O	C/O	C/O		N/L				N/L	N/L				
		Leading	PFLD														
Frequency	Frequency (phase A).	HZ	N/L									N/L	N/L				

* Amp Demand (AD) is replaced with kVA Demand (kVD) if the unit is equipped with the KVD or MDK option.

NOTES REGARDING DISPLAY LABELS:

- N/L = No Label.** The measured value is displayed on the front panel with no additional label.
 - Examples:
 - Voltage and current measurements are displayed under the VOLTS and AMPS fields without labels. The PHASE label indicates the phase.
 - MAX and MIN values are displayed momentarily using the MAX and MIN buttons. No additional labels are used.
 - kW Total is displayed as kW. No label indicating total is used.
- C/O = Communications Only.** The parameter is only accessible via the communications port.
 - Examples:
 - Per phase readings for kW, kVAR, kVA, and PF must be read via communications. 3-phase totals are available from the front panel.
 - kWH and kVARH Total (import + export) values must be read via communications. Import and export values are available from the front panel.
- Phase Labels.** A PHASE label with a comma indicates line-to-line measurements are being displayed. An asterisk represents average of the three phases.

Figure 4.1.2 Measurement Specifications

PARAMETER	ACCURACY ³ (% of full scale)	FRONT PANEL DISPLAY	
		Resolution	Range
Voltage	0.2%	0.1%	0 - 999,999 ¹
Current	0.2%	0.1%	0 - 30,000
I4	0.2%	0.1%	0 - 9,999
Vaux	0.25%	0.1%	0 - 999,999
kW	0.4%	0.1%	0 - 999,999 ²
kVAR	0.4%	0.1%	0 - 999,999 ²
kVA	0.4%	0.1%	0 - 999,999 ²
kWH	0.4%	1 kWH	0 - 999,999,999
kVARH	0.4%	1 kVARH	0 - 999,999,999
kVAH	0.4%	1 kVAH	0 - 999,999,999
Power Factor	1.0%	1.0%	-0.6 to 1.0 to +0.6
Frequency	0.2 Hz	0.1 Hz	40 to 450 Hz

NOTES:

1. Reads in kV for voltages over 9,999
2. Reads in MVA, MW, MVAR for readings over 9,999k
3. @50.0 Hz or @60.0 Hz @ 25°C (77°F)

Figure 4.1.3 Status Information

TYPE	SOURCE	CONDITION
Relay Output	Relay x x = 1, 2, or 3	Released (Inactive)
		Operated (Active)
Status Input	Status Input x x = 1, 2, 3, or 4	Inactive
		Active
Status Input Counter	S1 Status Counter	Accumulated Pulse Count
Setpoint	Setpoint xx xx = 1 to 17	Inactive
		Active

4.2 MEASURED PARAMETERS

4.2.1 REAL TIME

Real-time parameters include all voltage, current, power, power factor, frequency, and auxiliary (VAUX) measurements. For phase dependent measurements, this includes per phase readings, and averages or totals for all phases.

All real-time voltage, current, power, and auxiliary measurements are true RMS and are updated each second.

Additional measurement modes available for real-time parameters include demand and minima/maxima.

NOTES	
1.	Response to incremental changes in line frequency of over 1.0 Hz is 1 second. For incremental changes in frequency of under 1.0 Hz, the 3710 ACM continuously averages over a period of 10 seconds to obtain the rated accuracy.
2.	Conventions used for power factor lead/lag are discussed in Section 4.3.4.

4.2.2 ENERGY

Introduction

Energy parameters include kW hours (kWH), kVAR hours (kVARH), and kVA hours (kVAH). All energy parameters represent the *total* for all 3 phases. kWH and kVARH each provide three separate measurement modes which indicate bi-directional power flow (see Section 4.3.3).

Energy readings are true RMS and are updated once each second. Maximum range of energy readings is 999,999,999. Beyond this value, readings will roll over to zero (0).

Resetting the Energy Counters

You can reset all kWH, kVARH and kVAH counters to zero (0) using the CLEAR HOURS? parameter from the front panel in programming mode, or via communications. This clears the import, export, and total counters for each parameter.

4.3 MEASUREMENT MODES

Some measured parameters can provide additional *measurement modes*. The modes available are dependent on the parameter type. Figure 4.1.1 lists all modes applicable to each measured parameter.

4.3.1 DEMAND

Introduction

Power utilities generally bill commercial customers based on both their energy consumption (in kWH) and their peak usage levels, called *peak demand* (in kW). Demand is a measure of average power consumption over a fixed time period, typically 30 minutes. Peak (or maximum) demand is the highest demand level recorded over the billing period.

Demand measurement methods and intervals vary between power utilities. Some common methods include: thermal averaging, sliding window, and fixed interval techniques. The 3710 ACM performs demand calculations using the sliding window demand technique.

Sliding Window Demand Measurements

The 3710 ACM provides two sliding window demand measurements. These include kW Demand and Amp Demand.*

To compute these values, the 3710 ACM uses the *sliding window averaging* (or *rolling interval*) technique which divides the demand interval into sub-periods. The demand is measured electronically based on the average load level over the most recent set of sub-periods. This has the effect of improving the response time as compared to the fixed interval method.

Similar to thermal demand, the DEMAND PERIOD and NUM DEMAND PERIOD parameters allow you to match the power utility's demand calculation technique. For sliding window measurements, DEMAND PERIOD represents the length of the utility's demand sub-period, while NUM DEMAND PERIOD represents the number of sub-periods which make up the total demand interval. For example, with a 6 x 5 minute (30 minutes total) sliding window method, demand will be the average power consumption over the last six 5-minute periods. This allows you to match virtually any type of sliding window measurement method used by the utilities (e.g. 15x2, 6x5, 1x30).

Each sliding window demand measurement also has associated maxima/minima parameters that are available using the MAX and MIN buttons.

NOTE
Using the sliding window method, the 3710 ACM readings will always be as high or slightly higher than the utility readings.

* Amp Demand is replaced by kVA Demand for units equipped with either the KVD or MDK options.

External Demand Synchronization

When the DEMAND PERIOD parameter is set to zero, *external synchronization mode* is selected and the 3710 ACM no longer internally times the duration of each demand period. Instead, it looks for a pulse (INACTIVE to ACTIVE transition) on status input S4 to indicate the start of the subsequent demand interval. The NUM DEMAND PERIOD parameter is still operational in this mode and can be used to set the number of sub-periods which make up the total demand interval.

4.3.2 MAXIMA/MINIMA

Introduction

The 3710 ACM maintains all min/max values in its on-board Min/Max Log. This log records the extreme values for all real-time and demand parameters. Maxima and minima can be displayed using the MAX and MIN buttons on the front panel.

Resetting Min / Max Parameters

All min/max values in the Min/Max Log can be cleared using the CLEAR MIN/MAX? parameter from the front panel in programming mode or via communications.

4.3.3 BI-DIRECTIONAL ENERGY

Energy measurements represent the kWh, kVARH or kVAH sums for all three phases. Energy parameters provide three measurement modes which indicate bi-directional power flow: *import*, *export*, and *total*.

Total energy measurements represent the sum of the absolute values of imported and exported energy. Total energy values are incremented by energy being imported or exported.

kWH and kVARH can provide all three modes. The kVAH energy parameter provides only a *total* reading. Imported real or reactive energy is displayed with an F suffix (kWH-F, kVARH-F) indicating *forward* flow. Exported energy values are displayed with an R suffix (kWH-R, kVARH-R) indicating *reverse* flow.

NOTE

1. Only kWh import/export, kVARH import/export and kVAH total measurements can be displayed from the front panel. kWh and kVARH total values can be read only via communications.
2. Conventions used for energy import/export are described in Section 4.3.4.

4.3.4 POWER READING POLARITIES

Figure 4.3.4 illustrates how the 3710 ACM interprets and displays signed values for power, energy import/export indication, and power factor leading/lagging indication.

NOTE

The polarity of energy import/export readings can be reversed by reversing the polarity of the CTs connected to the 3710 ACM.

4.4 STATUS INFORMATION

Status information includes the present conditions of the three on-board relays, four (digital) status inputs, S1 status input counter, and seventeen user-programmable setpoints. Status information is not available from the front panel; however, it can be accessed via communications. Relay and status input operation are described in detail in Chapter 3. Setpoint operation is described in Chapter 5.

Resetting the Status Input Counter

The status input S1 counter value can be reset to zero (0) via communications.

Figure 4.3.4 3710 ACM Power Reading Polarities

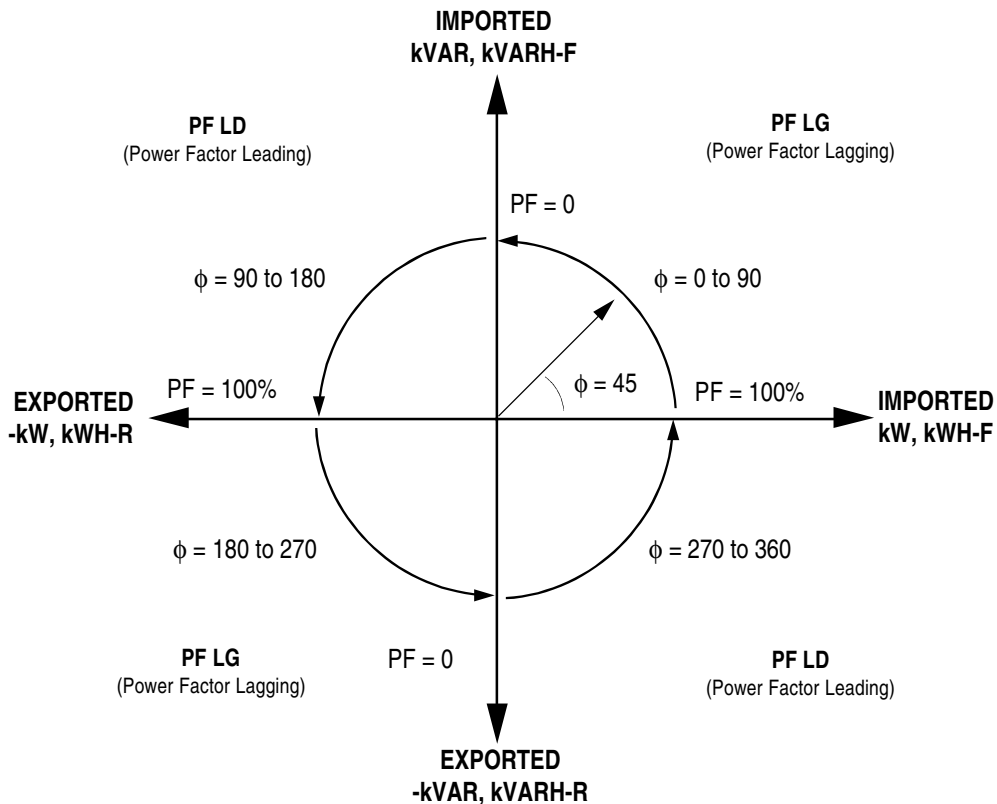
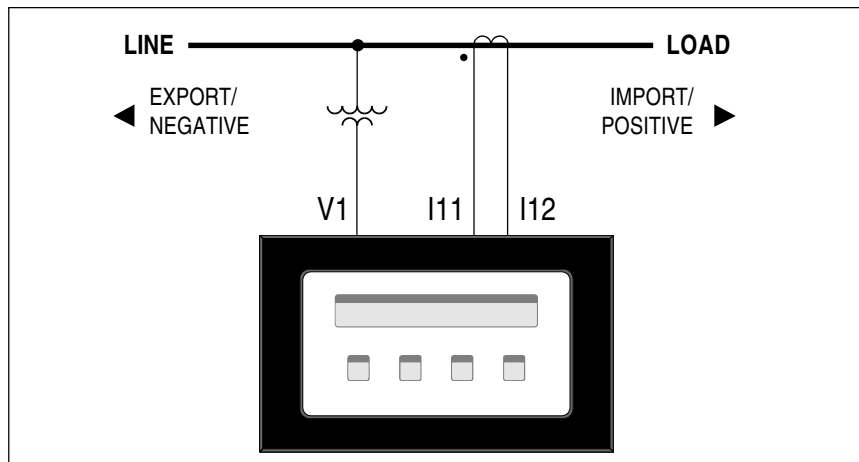

5 SETPOINT SYSTEM

5.1 INTRODUCTION

The 3710 ACM user-programmable setpoint system provides a host of control, protection, and analysis tools. Setpoints provide extensive control over the three on-board relay outputs. Seventeen individual setpoints are provided.

Setpoint-controlled relays can be used to perform such functions as automated demand, power factor, or voltage control. Setpoints can also enhance system reliability and safety by protecting against such conditions as neutral current or transformer heating, and ground current leakage. Upon the detection of a fault condition, the on-board relays can be used to activate external alarms.

Programmability

A group of programmable parameters specify how a setpoint is to operate:

- The TRIGGER parameter defines the parameter a setpoint is to monitor. This can be a measured parameter, status input condition, etc.
- Two setpoint *limits* are provided (HI LIMIT, LO LIMIT). One of these limits defines the value of the trigger parameter which will activate the setpoint. The other limit defines the value of the trigger parameter which will deactivate the setpoint.
- The RELAY NUMBER parameter defines which relay an active setpoint condition will operate.
- Two programmable time delays are provided. The *time delay to operate* (TD OPERATE) is the time delay between when a setpoint becomes active and the associated setpoint *action* is triggered. The *time delay to release* (TD RELEASE) parameter is used when a setpoint has been configured to control a relay. The parameter defines the time delay between when the setpoint returns to its inactive state and when the assigned relay is released.

Applications Flexibility

Setpoint programming is extremely flexible to facilitate a wide range of alarm, control, and analysis applications. Each of the seventeen setpoints can be programmed to concurrently monitor a separate parameter. For multi-level control, more than one setpoint can monitor the same parameter. Multiple setpoints can also be assigned to control the same relay (i.e. "OR" function). Figure 5.1.1 illustrates the wide range of setpoint capabilities.

Event Logging

All setpoint activation and deactivation conditions are automatically recorded in the on-board Event Log. This includes any setpoints which become activated, but are not programmed to perform any subsequent setpoint actions (relay control, etc.)

Event Log entries include the date and time of the setpoint event, the condition of the three relays, and the value of the trigger parameter. The Event Log is described in more detail in Chapter 7.

High Reliability

The 3710 ACM continuously monitors all setpoint conditions, uninterrupted by the execution of other on-board measurement, control or logging operations. This means that critical setpoint-related events of short duration will always be captured.

The following sections describe setpoint operation and programming in detail.

Figure 5.1.1 Setpoint Capabilities

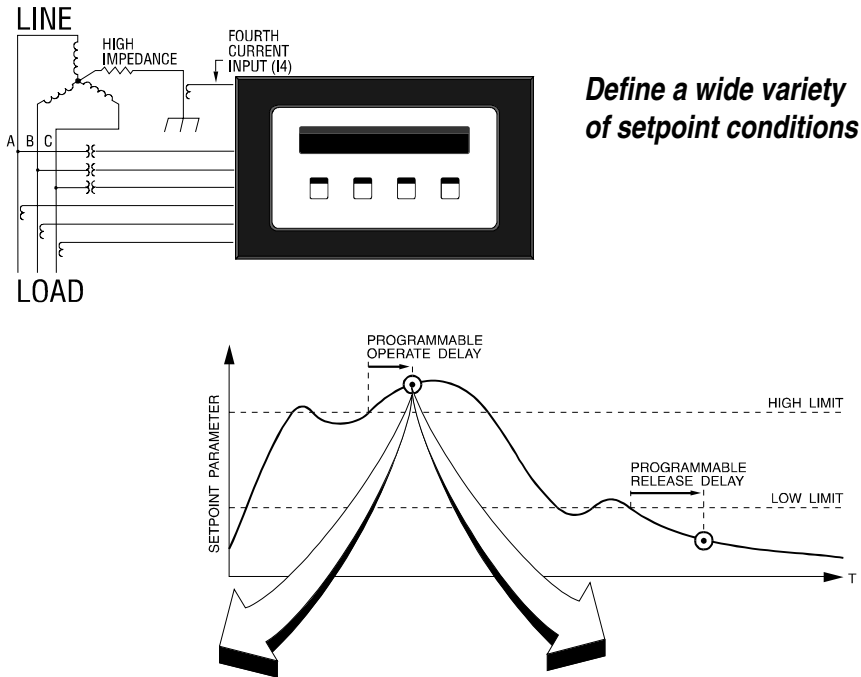

Record Active Setpoints

3710 ACM Event Log Screen		Updated at 15:29:58 Feb 15, 1993				
SITE: COGEN SITE #1			DEVICE: BRKR T4-38			
EVENT	STATE	VALUE	RELAY	DATE	TIME	
OVER VOLT A	301	ACTIVE R2	ON /ON /ON	93/02/15	15:20:30	
REVERSE POWER A	-1003	ACTIVE R3	ON /OFF /ON	93/02/13	08:22:31	
UNDER KW DEMAND	1410	ON /OFF /OFF	ON /OFF /OFF	93/02/13	07:52:11	
UNDER FREQUENCY	59.5	ACTIVE R1	ON /ON /OFF	93/02/11	23:01:55	
OVER VOLT B	303	ACTIVE R2	OFF /ON /OFF	93/02/09	02:42:34	
OVER KVA	1440	OFF /OFF /OFF	OFF /OFF /OFF	93/02/05	15:09:14	
OVER AMP A	1003	ACTIVE R3	OFF /OFF /ON	93/02/03	03:23:44	
UNDER VOLT C	250	ACTIVE R1	ON /OFF /OFF	93/02/01	23:09:34	
OVER VOLT B	300	ACTIVE R2	OFF /ON /OFF	93/02/01	14:03:08	
ALARMS CHANGED	COMM PACKET	OFF /OFF /OFF	OFF /OFF /OFF	93/01/24	10:05:52	

Move: Arrows Home End PgUp PgDn Alt-S Print: F4 Exit: Esc

Perform Automated Relay Protective & Control Functions

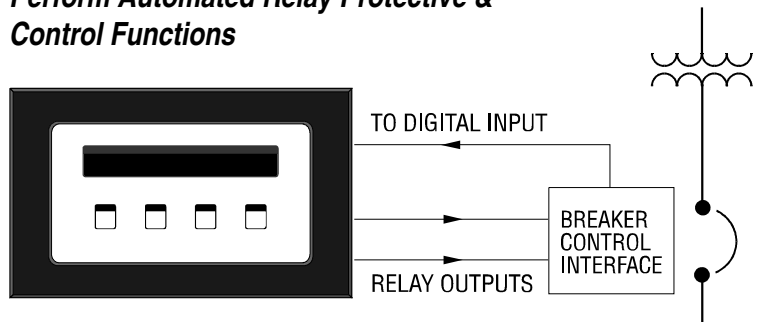

5.2 SETPOINT RESPONSE TIMES

Normal Operation Response

Under normal operating conditions, the response time of setpoint functions is defined as the time lapse between a setpoint *event* occurring and an associated setpoint *action* being executed. Response time is 1 second (typical), 2 seconds (maximum).

Power Up Response

Response time could be up to 5 seconds after initial meter power up. The 3710 ACM should not be used for protective functions which require faster operation. A battery-backed DC power supply should be considered for 3710 ACM devices whose setpoints are being used perform protective functions where response time is important.

CAUTION

The 3710 ACM on-board relays have a response time of 8 milliseconds (typical), 15 milliseconds (maximum). This does not include any additional contact bounce which may occur. This response must be added to the setpoint response time when using setpoints to trigger relay control actions.

CAUTION

The 3710 ACM is not intended for use as a primary overcurrent protection device. 3710 ACM setpoint relay control capabilities are designed to execute a variety of less critical functions.

5.3 TRIGGER PARAMETERS

5.3.1 INTRODUCTION

Figure 5.3.1 lists all trigger parameters. This section describes the characteristics of various types of trigger parameters in detail.

Figure 5.3.1 Setpoint Trigger Parameters

SETPOINT TRIGGER PARAMETERS	
PARAMETER	DESCRIPTION
NOT USED	Disables the setpoint.
OVER VOLTAGE	Over voltage (highest of the three phases).
UNDER VOLTAGE	Under voltage (lowest of the three phases).
VOLTAGE UNBAL	% difference of the most deviant phase voltage from the average.
OVER CURRENT	Over current (highest of the three phases).
CURRENT UNBAL	% difference of most deviant phase current from the average.
OVER KVA	Over total apparent power.
OVER KW FWD	Over total imported real power.
OVER KW REV	Over total exported real power (fed back into utility grid).
OVER KVAR FWD	Over total imported reactive power.
OVER KVAR REV	Over total exported reactive power (fed back into utility grid).
OVER KWD	Over total kW demand.
OVER AMPD ³	Over total current demand.
OVER FREQUENCY ¹	Over frequency.
UNDER FREQUENCY ¹	Under frequency.
OVER VAUX	Over auxiliary voltage.
UNDER VAUX	Under auxiliary voltage.
PHASE REVERSAL ²	Operates if the phase rotation does not match the programmable PHASE ROTATION parameter.
UNDER PF LAG	Under total power factor lagging.
UNDER PF LEAD	Under total power factor leading.
OVER I4	Over I4 current (neutral/ground)
Sn NORMAL	Status input Sn becomes inactive (n = 1 to 4).
Sn ACTIVE	Status input Sn becomes active (n = 1 to 4).
SX NORMAL	Any status input becomes inactive ("OR" function).
SX ACTIVE	Any status input becomes active ("OR" function).
NOTES	
1.	High and low limits for FREQUENCY are specified as (frequency x 10). Example: 60.0 Hz is specified as 600.
2.	PHASE REVERSAL trigger parameter does not function if VOLTS MODE = SINGLE or 3W-WYE.
3.	Amp Demand setpoint is replaced by kVA Demand if the unit is equipped with either the KVD or MDK option.

5.3.2 OVER & UNDER SETPOINTS

Many trigger parameters can function either as an *over* setpoint (e.g. *over current*) or an *under* setpoint (e.g. *under voltage*).

Figure 5.3.2a illustrates the operation of an *over* setpoint. An over setpoint becomes active when the parameter that is being monitored exceeds and remains over the value of the programmable *high limit* (HI LIMIT) parameter for a time greater than the value of the *time delay to operate* (TD OPERATE) parameter. An over setpoint becomes inactive when the trigger parameter that is being monitored falls below the value of the *low limit* (LO LIMIT) parameter for a time greater than the value of the *time delay to release* (TD RELEASE) parameter. The differential between the high and low limits effectively produces a programmable level of operational *hysteresis* (or *deadband*).

Figure 5.3.2a Over Setpoint Operation

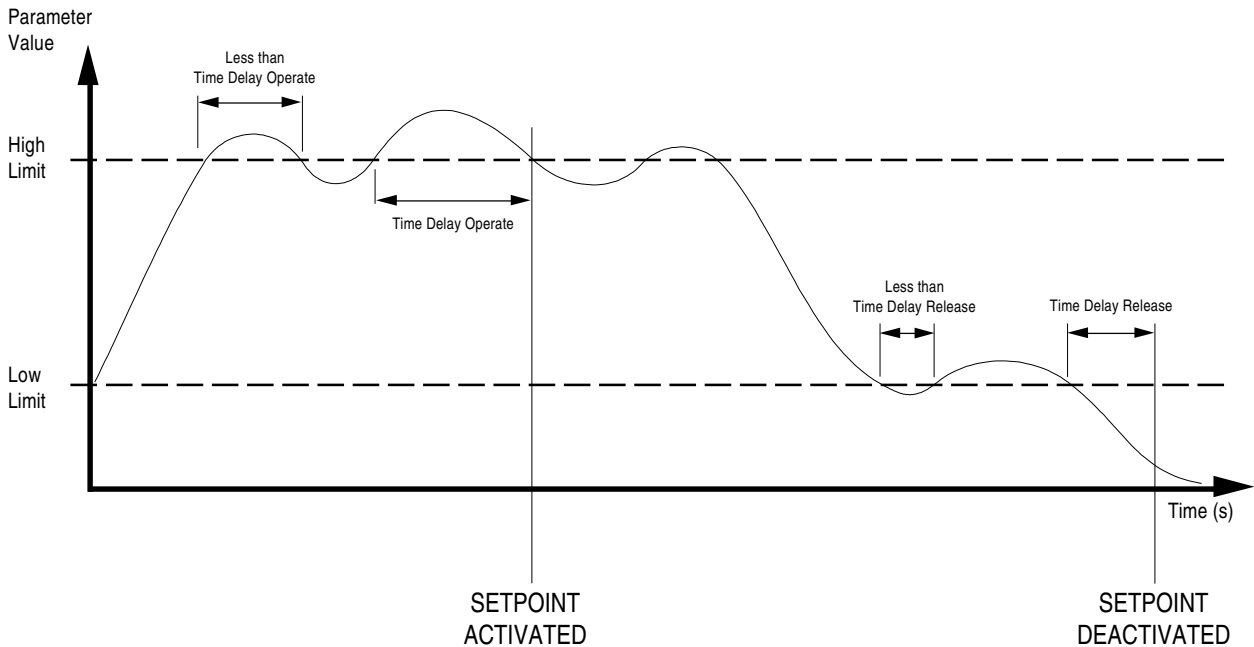
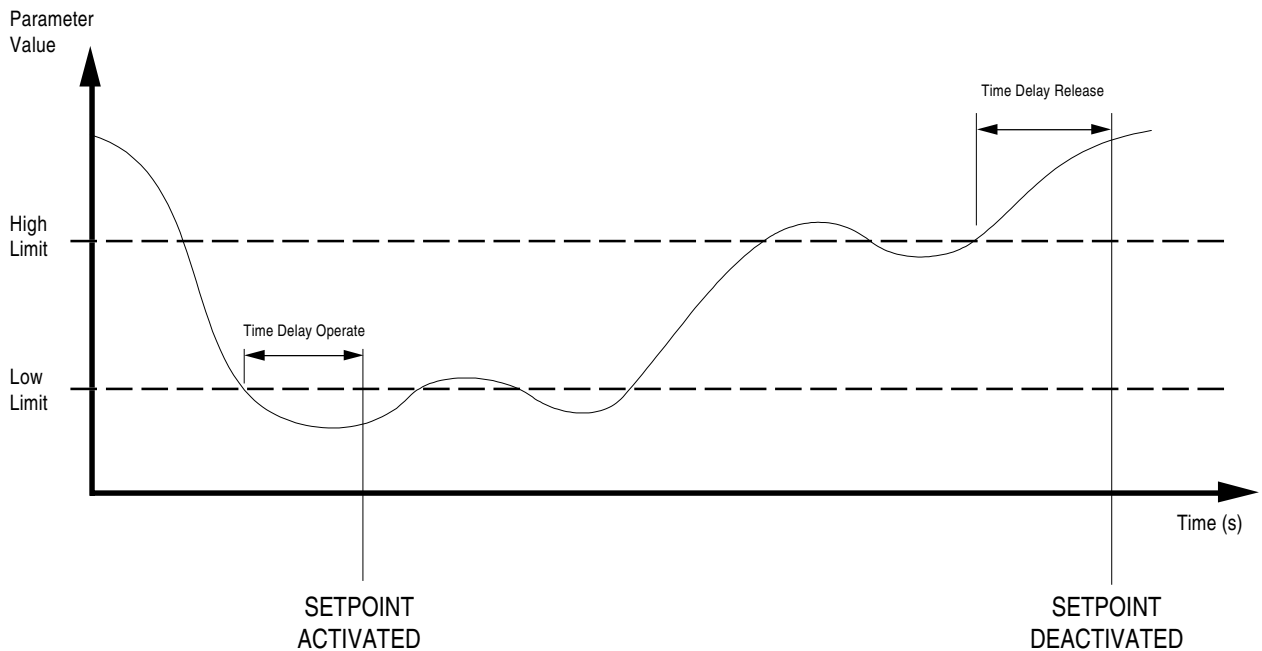

Figure 5.3.2b illustrates the operation of an *under* setpoint. An under setpoint differs only in that the meanings of high limit and low limit are reversed. The setpoint becomes active when the trigger parameter falls below the value of the LO LIMIT parameter for a time greater than the value of the TD OPERATE parameter. The under setpoint becomes inactive when the parameter exceeds and remains over the value of the HI LIMIT parameter for a time greater than the value of the TD RELEASE parameter. Similar to over setpoint operation, the differential between the high and low limits produces an area of hysteresis.

Figure 5.3.2b UnderSetpoint Operation



5.3.3 ON/OFF & COUNTER SETPOINTS

Some trigger parameters provide a simple *on* or *off* condition, such as phase reversal, or status input conditions. For status input types, setpoints can monitor the condition of individual inputs (e.g. *s1 ACTIVE*, *s2 NORMAL*, etc.) or monitor all four status inputs together (e.g. *sx ACTIVE*). This second method effectively operates as a Boolean “OR” function. For all on/off trigger parameters, the setpoint becomes active when the defined condition becomes true. These trigger parameters do not use the high or low limit parameters (*HI LIMIT*, *LO LIMIT*).

5.4 RELAY CONTROL

Any of the three on-board relays of the 3710 ACM can be automatically controlled by a setpoint. Setpoint-controlled relays can perform a wide range of operations, including:

- Shunt tripping a breaker.
- Activating an alarm buzzer or light.
- Controlling an external piece of equipment.

NOTE

Refer to Section 5.2 for information regarding setpoint and relay response times and other considerations.

A relay assigned to a setpoint is automatically operated when the setpoint becomes active, and released when the setpoint returns to its inactive state.

Programming

To configure a setpoint for relay control, you must program the parameters for both the setpoint and for the assigned relay:

- The *RELAY NUMBER* parameter for the setpoint must be set to the desired relay number (1, 2, 3). A value of 0 will disable any relay action.
- The *RX MODE* parameter for the assigned relay must be defined as *SETPOINT*.

The programmable *time delay to operate* (*TD OPERATE*) delay can be used to provide a delay interval between when the setpoint becomes active and when the assigned relay is operated. The programmable *time delay to release* (*TD RELEASE*) delay can be used to provide a delay interval between when the setpoint returns to its inactive state and when the assigned relay is released.

Avoiding Operational Conflicts

As described in Chapter 3, relays may also be used for kWh or kVARH pulsing. Ensure that a relay configured for hour pulsing is not also assigned to setpoint operation. Pulsing operations will always override setpoint control.

Multi-Level and Multi-Function Relay Control

The 3710 ACM setpoint system allows for multi-level and multi-function relay control operations. The following examples illustrate this flexibility.

EXAMPLES

1. By assigning the same relay number to more than one setpoint, multiple setpoints can be channelled to a single relay. This feature can effectively produce a Boolean “OR” function. This also allows a single relay to perform multiple functions; however, as mentioned above, care must be taken to avoid operational conflicts.
2. You wish to configure a two-level relay protection scheme. First assign two setpoints to monitor the same trigger parameter (e.g. *over current*). Set each setpoint to trigger on a different parameter limit, one higher than the other (e.g. *SP1 HI LIMIT = 500*, *SP2 HI LIMIT = 750*). Configure each setpoint to control a different relay (e.g. *SP1 RELAY NUMBER = 1*, *SP2 RELAY NUMBER = 2*). Each relay could control a different external protection device. As the value of the measured parameter increases, each relay will trip in sequence.

Manual Forced Relay Override

A relay configured for setpoint control (*RX MODE = SETPOINT*) may be forced operated or released using commands made via communications. Manual commands override any present setpoint-controlled relay operations. Once a command to *return to normal* is issued via communications, the affected relay is immediately returned to setpoint control.

5.5 PROGRAMMING SETPOINTS

Setpoint Parameter Form

Setpoint use should be planned using a *Setpoint Parameter Form*. Appendix B provides a blank Setpoint Parameter Form for this purpose. This form allows you to record the setpoint information that you program into the 3710 ACM. A copy of this information should be kept with the meter.

Programming Example

Figure 5.5.1 provides an example of a Setpoint Parameter Form being used to plan setpoint usage. The form contains all of the parameter values required to program the 3710 ACM to perform the operations described in the following example.

EXAMPLE

1. Setpoints SP1 to SP4 are used to sense over voltage, under voltage, voltage unbalance, and phase reversal conditions. All four setpoints are triggering Relay 1 to operate as a trip relay, which is connected to a breaker shunt trip input.

2. Setpoints SP7 to SP8 are being used to sense loads which are over 70% of the breaker rating. This includes over current and over voltage conditions. Setpoints SP9 to SP10 are being used to sense excessive power factor lead or lag. For all these conditions, Relay 2 is being triggered to operate as an alarm relay, with its output connected to a buzzer.
3. Relay 3 is used as a kW Demand control relay, and is connected to a sheddable load or backup generator.

Disabled Relay Control in Programming Mode

After the correct password has been entered in programming mode, no setpoint-controlled relay operation will occur until after you have exited the programming mode. The 3710 ACM will then assess the status of each setpoint and perform any required operations.

Figure 5.5.1 Setpoint Parameter Form Example

SETPOINT PARAMETER FORM						
SETPOINT	TRIGGER	HI LIM	TD OP	LO LIM	TD REL	ACTION
SP1	Over Voltage	332	5	290	1	Relay 1, Trip
SP2	Under Voltage	270	5	220	1	Relay 1, Trip
SP3	Volts Unbalance	30%	5	10%	1	Relay 1, Trip
SP4	Phase Reversal	-	1	-	1	Relay 1, Trip
SP5	Not Used					
SP6	Not Used					
SP7	Over Current	2100	10	2000	1	Relay 2, Alarm
SP8	Over Voltage	300	10	290	1	Relay 2, Alarm
SP9	Under PF Lag	90	10	85	10	Relay 2, Alarm
SP10	Under PF Lead	90	10	85	10	Relay 2, Alarm
SP11	Over KWD	1200	10	900	10	Relay 3, Demand control
SP12	Not Used					
SP13	Not Used					
SP14	Not Used					
SP15	Not Used					
SP16	Not Used					
SP17	Not Used					

5.6 POWER OUTAGES

When the power feed to the 3710 ACM is interrupted, even momentarily, the output relays release. When power is restored, the 3710 ACM allows a 3 second settling time. After this interval the setpoint conditions are re-evaluated and, if appropriate, the relays will operate after the programmed time delays.

If any relay has been forced operated or forced released using commands made via the communications port prior to the power outage, it will be released when the outage occurs. When power has been restored, the 3710 ACM resumes normal setpoint operation as described above. Relays are not automatically returned to a forced operated or forced released condition following a power outage.

6 WAVEFORM CAPTURE

6.1 INTRODUCTION

The 3710 ACM has been equipped with digital waveform capture capabilities. Waveform capture can be used for detailed power quality analysis.

Waveform capture is triggered by commands made via communications.

6.2 THE IMPORTANCE OF POWER QUALITY MONITORING

Power quality has become a foremost concern for power utilities and their customers due to an increasing presence of induced harmonic voltages and currents in industrial, commercial and residential electrical supplies. Harmonics are typically generated within a facility's power distribution system by non-linear loads (variable frequency drives, UPS systems, HVAC and lighting systems, computers, etc.)

Poor power quality can have serious and potentially damaging consequences, including equipment malfunctions or failures, reduced efficiency and mechanical vibration in motors, or incorrect tripping and/or failure of circuit breakers. Harmonic currents from individual phases can also add in the neutral line, sometimes producing dangerously high neutral currents.

As harmonic sources become more prevalent, it is important to have the analytical tools necessary to identify potential problem sources and help in determining the preventative or corrective measures necessary to improve power quality in electrical distribution systems.

6.3 USING CAPTURED DATA

Waveform capture allows you to perform high-speed sampling of the V1, V2, V3, V_{AUX}, I1, I2, I3, or I4 (neutral current) inputs. One full cycle of the signal at a *single* selected input is sampled at a rate of 128 samples per cycle. All samples are taken synchronous to the line frequency and within one input cycle.

Sampled waveform data is stored in on-board memory and can be read via the communications port. The high sampling rate used by the 3710 ACM produces high-resolution data which allows analysis of frequency components to the 63rd harmonic.

POWER MEASUREMENT's SCADA software can be used to upload captured waveform data from the 3710 ACM to a master computer station and display the waveforms on the computer screen (see Figure 6.3.1). The SCADA software automatically performs a Fast Fourier Transform on each waveform, and provides an indication of total harmonic distortion and a breakdown of individual frequency components both in graphical (Figure 6.3.2) and tabular form (Figure 6.3.3) to the 63rd harmonic. This wide variety of data formats can help you to pinpoint quickly the source and severity of harmonics, evaluate which sources must be minimized, and develop corrective strategies.

6.4 TRIGGERING VIA COMMUNICATIONS

You can manually initiate capture of selected 3710 ACM inputs from the master computer station.

Using the SCADA software, you can perform waveform capture for each of the eight possible inputs individually. A command from the computer immediately initiates capture at the 3710 ACM. The computer then automatically uploads and displays the waveform on the screen. The waveforms captured in turn for each of the eight inputs can be displayed together on the screen, presented with correct phase relationships.

Figure 6.3.1 M-SCADA Captured Waveform Screen

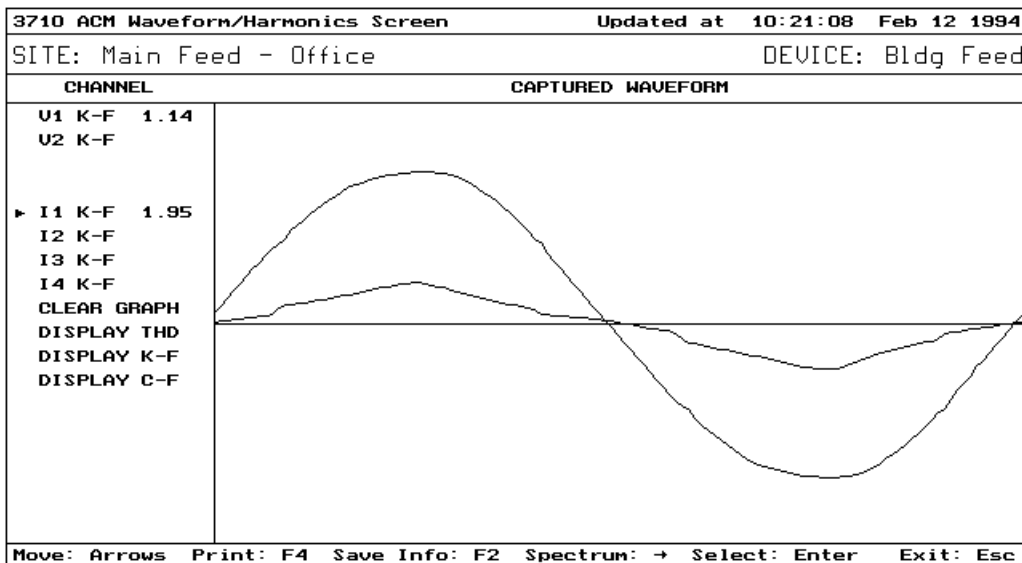

Figure 6.3.2 M-SCADA Harmonic Spectrum Screen

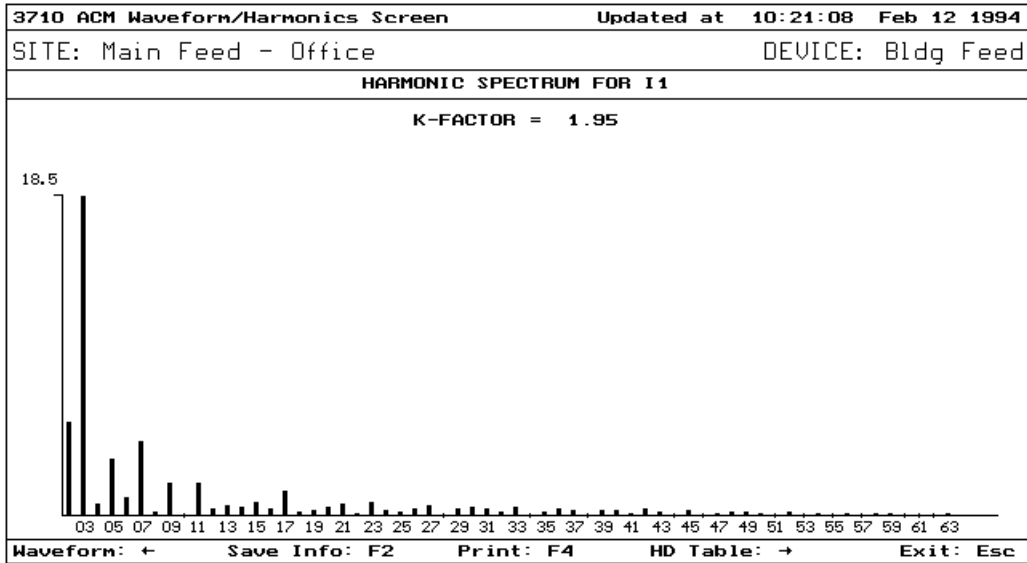

Figure 6.3.3 M-SCADA Harmonics Table Screen

3710 ACM Waveform/Harmonics Screen		Updated at 10:21:08 Feb 12 1994	
SITE: Main Feed - Office		DEVICE: Bldg Feed	
HARMONIC DISTORTION TABLE FOR I1			
Hn	%HD	Hn	%HD
01	100.0	33	0.5
03	18.4	35	0.2
05	3.3	37	0.3
07	4.3	39	0.3
09	1.9	41	0.1
11	1.9	43	0.3
13	0.6	45	0.3
15	0.7	47	0.1
17	1.5	49	0.2
19	0.3	51	0.0
21	0.7	53	0.1
23	0.7	55	0.1
25	0.2	57	0.1
27	0.6	59	0.1
29	0.4	61	0.0
31	0.4	63	0.1
02	5.4	34	0.1
04	0.7	36	0.4
06	1.1	38	0.1
08	0.2	40	0.3
10	0.1	42	0.4
12	0.5	44	0.1
14	0.5	46	0.1
16	0.4	48	0.3
18	0.2	50	0.2
20	0.5	52	0.2
22	0.1	54	0.1
24	0.3	56	0.2
26	0.4	58	0.1
28	0.1	60	0.1
30	0.5	62	0.0
32	0.2		
K-FACTOR = 1.95			
Spectrum: ←	Print: F4	Export Info: F2	Exit: Esc

7 ON-BOARD DATA LOGGING

7.1 INTRODUCTION

Data logging can be extremely useful in the study of growth patterns, for scheduling loads and for cost allocation, for isolating problem sources, or for analysing a variety of power system operating conditions.

The 3710 ACM supports three types of on-board data logging:

1. Event Log
2. Minimum / Maximum Logs
3. One Preset Snapshot Log

All logged data is stored in internal nonvolatile memory and is accessible via the communications port. Measured values from the Min/Max Log are also accessible from the front panel of the 3710 ACM using the MAX and MIN buttons.

7.2 EVENT LOG

The Event Log of the basic 3710 ACM automatically records the 50 most recent events.

A wide variety of event types are recorded by this log:

- Power-up and power-down activity.
- Setpoint (alarm) conditions.
- Relay activity. This includes operate/release actions triggered by setpoints or manually via communications.
- Status input activity. If desired, the logging of status input activity can be disabled via communications.
- Triggering of the waveform capture feature.

- Changes made to the user-programmable parameters from the front panel or via communications.
- Self-diagnostic events.

The Event Log can be used to record a complete sequence-of-events record for breaker and transfer switch operations, alarm conditions, and equipment starts and stops.

Figure 7.2.1 illustrates a typical 3710 ACM Event Log displayed by POWER MEASUREMENT'S SCADA software. Each event record stored in the Event Log includes:

1. EVENT (TYPE)
This identifies the setpoint, status input, user action, or other event type that occurred.
2. STATE
This identifies any setpoint-triggered relay action if the event was a setpoint being activated.
3. VALUE
If the event was a setpoint being activated or deactivated, the value of the measured parameter that triggered the setpoint will be recorded.
4. RELAY (STATUS)
The condition of each of the three relays is recorded at the time of the event.
5. DATE & TIME
The event is date and time-stamped. The date provides the year, month, and day. Event times are recorded in hours, minutes and seconds.

7.3 MINIMUM / MAXIMUM LOG

Figure 7.2.1 M-SCADA Event Log Screen

3710 ACM Event Log Screen				Updated at 12:16:36 Feb 08 1994	
SITE: Main Feed - Office			DEVICE: Bldg Feed		
EVENT	STATE	VALUE	RELAY	DATE	TIME
CLEARED HOURS	COMM PACKET		OFF/OFF/OFF	93/06/18	16:35:05
CLEARED HOURS	COMM PACKET		OFF/OFF/OFF	93/06/18	16:35:05
SETUP CHANGED	COMM PACKET		OFF/OFF/OFF	93/06/18	16:33:48
POWER UP/RESET			OFF/OFF/OFF	93/06/18	15:36:11
SETUP CHANGED	FRONT PANEL		OFF/OFF/OFF	93/06/03	13:00:24
OVER VOLTAGE PH B	NORMAL R1	123	OFF/OFF/OFF	93/06/01	16:24:21
SETUP CHANGED	FRONT PANEL		ON /OFF/OFF	93/06/01	16:24:20
OVER VOLTAGE PH C	ACTIVE R1	100159	ON /OFF/OFF	93/06/01	16:23:22
POWER UP/RESET			OFF/OFF/OFF	93/06/01	16:23:18
OVER VOLTAGE PH C	ACTIVE R1	100159	ON /OFF/OFF	93/06/01	16:23:08
POWER UP/RESET			OFF/OFF/OFF	93/06/01	16:23:04
SETUP CHANGED	COMM PACKET		ON /OFF/OFF	93/06/01	15:32:48
OVER VOLTAGE PH B	ACTIVE R1	1.000M	ON /OFF/OFF	93/06/01	15:32:30
SETUP CHANGED	COMM PACKET		OFF/OFF/OFF	93/06/01	15:32:29
SETUP CHANGED	COMM PACKET		OFF/OFF/OFF	93/06/01	15:31:39
CLEARED MIN/MAX	COMM PACKET		OFF/OFF/OFF	93/06/01	14:57:45
OVER VOLTAGE PH C	NORMAL R1	12030	OFF/OFF/OFF	93/06/01	14:53:56
SETUP CHANGED	FRONT PANEL		ON /OFF/OFF	93/06/01	14:53:55

Move: Arrows Home End PgUp PgDn Alt-S Print: F4 Exit: Esc

7.3.1 DESCRIPTION

The Min/Max Log automatically records the extreme values for all parameters measured by the 3710 ACM. This includes all voltage, current, power, frequency, power factor, and auxiliary input parameters. Minima and maxima are also provided for all demand measurement modes, including both thermal and user-defined sliding window parameters.

The 3710 ACM Preset Min/Max Log can be used to determine such values as the highest loading on a plant or feeder, peak demand, voltage operating ranges, worst case power factor, highest VAR loading for capacitor sizing, etc.

Minima and maxima for each parameter are logged independently with date and time stamp (see Figure 7.3.1). Each value in the Preset Min/Max Log can be accessed from the front panel of the 3710 ACM using the MAX and MIN buttons.

The minima and maxima values in the Min/Max Log can be reset together from either the front panel of the 3710 ACM, or via communications. From the front panel, set the CLEAR MIN/MAX? parameter to YES in programming mode. All values are reset when you advance to the next parameter, or return to display mode.

NOTE

Amp Demand is replaced by kVA Demand if the unit is equipped with either the KVD or MDK option.

7.3.2 RESETTING THE MIN/MAX LOG

Figure 7.3.1 M-SCADA Preset Min/Max Log Screen

3710 ACM Min/Max Log Screen							Updated at 15:02:20 Feb 08 1994	
SITE: Main Feed - Office					DEVICE: EMEM Feed			
PARAMETER		MIN VALUE	DATE	TIME	MAX VALUE	DATE	TIME	
VOLTS	PH A	10920	94/02/03	20:39:31	12599	94/02/04	17:50:12	
	PH B	10920	94/02/03	14:14:08	12599	94/02/03	11:53:46	
	PH C	10920	94/02/03	12:19:11	12599	94/02/03	20:16:07	
VOLTS	PH AB	18916	94/02/03	20:07:40	21820	94/02/06	17:06:53	
VOLTS	PH BC	18915	94/02/07	02:17:23	21817	94/02/04	06:21:18	
VOLTS	PH CA	18916	94/02/04	08:06:28	21820	94/02/07	05:50:23	
AMPS	PH A	150	94/02/04	06:57:56	660	94/02/03	12:38:40	
	PH B	150	94/02/03	11:59:37	659	94/02/04	11:17:58	
	PH C	150	94/02/03	23:11:57	660	94/02/04	05:00:49	
KW		4323	94/02/04	11:57:23	23198	94/02/03	14:06:53	
KVA		5289	94/02/04	11:57:23	24252	94/02/03	14:06:53	
KVAR		0	94/02/03	12:09:58	14093	94/02/04	02:24:36	
POWER FACTOR	LAG	80	94/02/03	11:46:22	100	94/02/03	12:09:10	
KW DEMAND		4745	94/02/04	11:59:59	22709	94/02/03	14:52:00	
AMP DEMAND		164	94/02/04	03:05:57	645	94/02/07	07:46:00	
FREQUENCY		60.0	94/02/03	11:38:39	60.0	94/02/03	11:38:39	
UAUX		1000	94/02/03	11:38:39	1000	94/02/03	11:38:39	
AMPS I4		5000	94/02/03	11:38:39	5000	94/02/03	11:38:39	

Move: Alt-S Print: F4 Clear Min/Max: F3 Exit: Esc

7.4 SNAPSHOT LOGS

7.4.1 INTRODUCTION

3710 ACM Snapshot Logs are *historical* or *trend* logs. The basic 3710 ACM provides a single *preset* (non-programmable) Snapshot Log.

Snapshot Logs can be used to replace traditional strip chart recorders. Data collected by the logs can be used to produce daily/weekly/monthly load profile graphs for power, demand, power factor, etc. Data can also be used for time-of-use or billing calculations.

7.4.2 PRESET SNAPSHOT LOG

The basic 3710 ACM provides a single Snapshot Log which records 12 channels of data. The 12 parameters recorded are non-programmable. These are as follows:

1. Voltage, average of all phases
2. Current, average of all phases
3. kW, total of all phases
4. kVAR, total of all phases
5. kW Demand, total of all phases
6. Amp Demand, total of all phases*
7. Power Factor, total of all phases
8. VALX
9. Frequency
10. kWh, total of all phases
11. kVARH, total of all phases
12. kWh Reverse, (exported) total of all phases

* Amp Demand is replaced by kVA Demand if the unit is equipped with either the KVD or MDK option.

Figure 7.4.2 illustrates a Preset Snapshot Log screen provided by the SCADA software. Note that the complete Snapshot Log data group consists of 3 screens, each displaying 4 of the 12 measured parameters. The figure shows the second of the three possible screens.

Figure 7.4.2 M-SCADA Preset Snapshot Log Screen

3710 ACM Snapshot Log Screen				Updated at 15:00:54 Feb 08 1994			
SITE: Main Feed - Office				DEVICE: Bldg Feed			
DATE	TIME	VOLTS	AUG	AMPS	AUG	KW	KUAR
94/02/08	15:00:00		121		67	21	8
94/02/08	14:45:00		121		85	28	9
94/02/08	14:30:00		122		89	29	8
94/02/08	14:15:00		121		146	49	13
94/02/08	14:00:00		122		70	23	8
94/02/08	13:45:00		122		65	20	7
94/02/08	13:30:00		122		151	51	14
94/02/08	13:15:00		121		135	45	14
94/02/08	13:00:00		121		73	24	9
94/02/08	12:45:00		121		80	25	9
94/02/08	12:30:00		121		145	50	11
94/02/08	12:15:00		121		153	52	12
94/02/08	12:00:00		121		80	25	9
94/02/08	11:45:00		121		69	22	8
94/02/08	11:30:00		121		93	30	11
94/02/08	11:15:00		121		77	25	8
94/02/08	11:00:00		121		87	28	9
94/02/08	10:45:00		122		144	49	11

Move: Keypad Alt-S Print: F4 Trending: F10 Exit: Esc

7.4.4 TIME INTERVAL TRIGGERING

Time interval triggering allows Preset Logs to run continuously, automatically recording all channels of data at user-defined time intervals. Time interval range is 1 second to 400 days.

This method of triggering a log is ideal for analysing power usage trends for the study of growth patterns, or for scheduling loads. Historical data recorded using a time interval triggered Snapshot Log can be graphically viewed in the SCADA software using the *Historical Trending* feature (see Figure 7.4.4).

7.5 ACCESS TO LOGGED DATA

The Event, Min/Max, and Snapshot Logs of the 3710 ACM are stored on-board in nonvolatile memory and are accessible via communications.

POWER MEASUREMENT'S SCADA software, or any compatible third-party software, can be used to read this data. The SCADA software can also automatically archive to disk all logged data retrieved from each remote device on a user-defined schedule basis (daily, monthly, yearly, etc.) The SCADA software provides a number of different options for displaying logged data, and can also convert logged data into formats compatible with a wide variety of third-party database programs for further analysis.

Figure 7.4.4 M-SCADA Historical Trending Screen

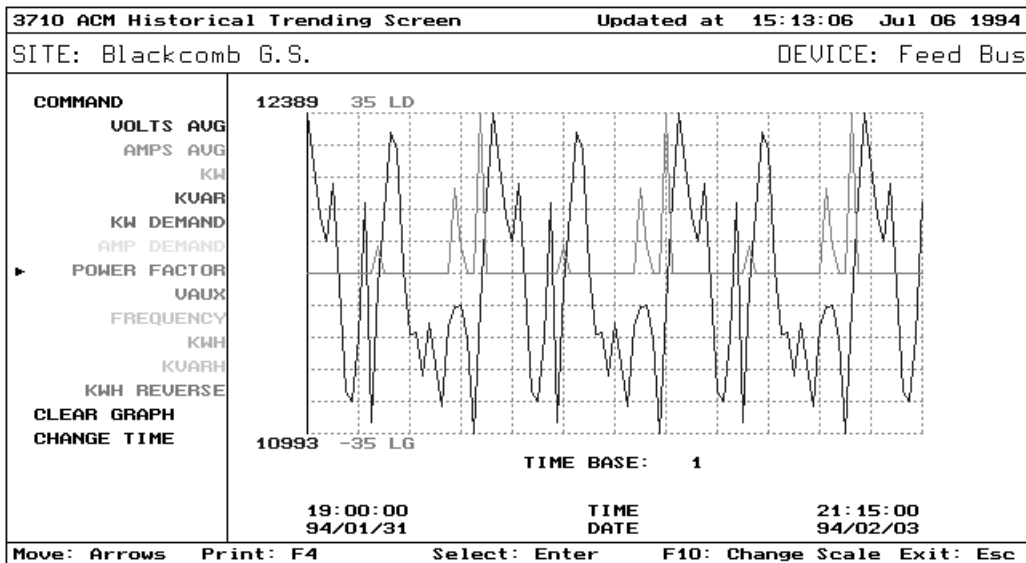

8 COMMUNICATIONS

8.1 GENERAL

The 3710 ACM is equipped with a communications port which allows the 3710 ACM to be integrated within large energy monitoring networks. The communications port is optically isolated and transient protected. It is field-configurable for EIA RS-232 or RS-485 standards, and can operate at baud rates up to 19,200.

The communications port provides the user with access to the advanced features of the 3710 ACM not available from the device's front panel. These include waveform capture and recording, data logging, and many of the setup parameters for the setpoint system and other features.

The 3710 ACM is fully compatible with POWER MEASUREMENT's PC-based SCADA system. The SCADA software can display all measured parameters and status information, waveform data, and data logs provided by the 3710 ACM. The SCADA software can also be used to remotely program the setup parameters for all basic and advanced features. An open communications protocol allows similar access by third-party systems.

This chapter provides additional information regarding remote communications connections, programming, and general operation.

8.2 RS-232 COMMUNICATION

Direct Connection

RS-232 is commonly used for short distance, point-to-point communications. Connection between a host computer (or PLC) and a *single* remote device must be less than 50 feet. Figures 2.6.4a and 2.6.4b in Chapter 2 provide wiring diagrams for direct RS-232 connection and the required wiring for the RS-232 interconnect cable(s).

Modem Connection

Connection using modems via dedicated or dial-up telephone lines is also possible (see Figure 8.2.1).

When using a modem, it is important that the computer-to-modem and modem-to-POWER MEASUREMENT device cable connections illustrated in Figure 2.6.4b in Chapter 2 are used.

Using the RTS Line

The RS-232 port RTS line is operational and can be used if required by any hardware device connected to the 3710 ACM. POWER MEASUREMENT's SCADA system does not require the use of the RTS line for direct RS-232 connections; however, some types of modems (e.g. radio modems) may require its operation.

The RTS signal is asserted high at least 11 milliseconds before the beginning of a transmission, and remains asserted high throughout the transmission.

The programmable RTS, ACTIVE LVL parameter selects whether the RTS line is asserted HIGH or LOW during transmission.

Figure 8.2.1 Remote Communication Methods

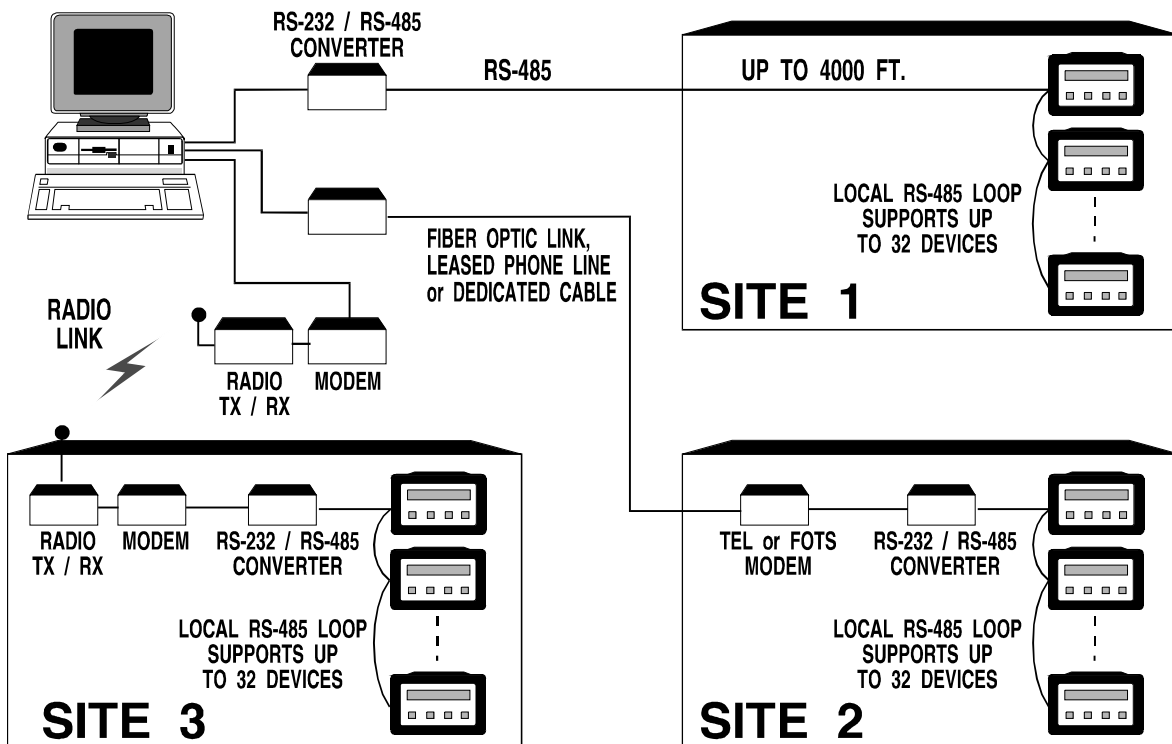

8.3 RS-485 COMMUNICATION

RS-485 is used when multiple devices are installed at a remote site. RS-485 communication can be used to concurrently connect up to thirty-two remote devices on a single communications loop. Each device is given a unique UNIT ID (identification number). In this way, each remote device may be monitored and controlled from one location by a single computer/PLC.

The total distance limitation on a single RS-485 communication network is 4000 feet using 22 gauge twisted pair shielded cable. Figure 2.6.5b in Chapter 2 provides a wiring diagram for RS-485 network connection.

Communication methods between the remote RS-485 site and the master computer station can include a direct RS-485 connection (under 4000 ft.), telephone lines with modems, fibre-optic and/or radio links. An RS-232 to RS-485 converter, such as POWER MEASUREMENT'S COM128, is required between the RS-232 port of the computer or modem and the RS-485 network (see Chapter 2, Figure 2.6.5b).

8.4 SETTING THE UNIT I.D. & BAUD RATE

Before communication with the host computer/PLC is possible, the user must first ensure that the 3710 ACM, and all other connected devices, have been configured for the required communications standard (RS-232 or RS-485). Instructions for 3710 ACM communication card configuration are provided in Chapter 2, Section 2.6.2.

The next step is to program the communication parameters of the 3710 ACM, and all other connected devices. The UNIT ID and BAUD RATE parameters of the 3710 ACM can be programmed via the front panel. The UNIT ID must be set to a unique value between 1 and 9999. The BAUD RATE of each device on the network must be set to correspond with the baud rate selected for the computer. Options include 300, 1200, 2400, 9600 or 19,200 baud. For UNIT ID and BAUD RATE settings for the PLC/MOD option, refer to Chapter 8, Section 8.9.3.

WARNING

When using a modem interface between the host computer and any remote device(s), ensure that the host computer is not used to set the BAUD RATE parameter of any selected device outside the working range of the modem. Doing so will cause that meter to cease communicating. Re-establishing communication with that meter is then only possible through performing the following:

1. Reset the baud rate of the remote device *from its front panel* to a value within the working range of the modem.
2. Set the computer to communicate at the baud rate at which the remote device has been set to communicate.

8.5 3710 ACM TRAN MODEL OPERATION

The TRAN version of the 3710 ACM provides all the functions of the 3710 ACM, except that it has no front panel display or keypad. All measured parameters, status information, and programming parameters are accessed via communications.

To initiate communications with the device, the factory-set UNIT ID and BAUD RATE must be used:

- UNIT ID is set at the factory to be the last 4 digits of the unit's serial number, which can be found on the rear cover of the unit. For example, a unit with serial number 71317 will be preset to UNIT ID of 1317.
- BAUD RATE is set at the factory to 9600 baud.

Once communication has been established using the factory defaults, the device's operating parameters may be changed using the remote computer. The user may also reset the UNIT ID of the device to any other desired value, as well as resetting the BAUD RATE. Refer to Section 8.4 for important information regarding resetting the BAUD RATE.

8.6 POWER MEASUREMENT'S SCADA SYSTEM

The 3710 ACM is compatible with POWER MEASUREMENT's PC-based power monitoring software packages, M-SCADA, L-SCADA, PowerView, and entire family of 3000 series digital instrumentation, which includes power meters, power demand controllers, and smart transducer interfaces. A single M-SCADA station can support up to 99 remote sites with a total of 3168 devices. Systems are easily expandable, and very large systems can be built by linking multiple master stations.

M-SCADA provides extensive full-colour data display options, automated data handling and system control features including:

- Real-time data display for all or part of the power system. Full colour, user-configurable *system diagrams* can be used to give a system-wide display of power conditions. Real-time and logged data for individual devices can also be viewed.
- Display of captured waveforms for harmonic analysis and fault or surge/sag analysis*. M-SCADA can provide detailed power quality analysis to the 63rd harmonic in graphical or tabular formats.
- Historical trend graphing. M-SCADA can display historical, time-interval triggered Snapshot Log data in graphical format.
- Detection, annunciation, display and logging of alarm conditions.
- Automatic retrieval and disk archival of data logs from remote devices.
- Manual control of the on-board relays of all POWER MEASUREMENT devices.
- Remote programming of the setup parameters of all POWER MEASUREMENT devices.

POWER MEASUREMENT's proven *distributed processing* approach to power monitoring guarantees consistently accurate data retrieval by delegating extensive data acquisition, data logging, and control capabilities to the remote meter/RTU sites. Less processing requirements at the master station means high reliability and performance. Nonvolatile data logs ensure data is always retrievable following a temporary power or communication failure.

Contact POWER MEASUREMENT or your local POWER MEASUREMENT representative for detailed information on the SCADA System and the complete range of POWER MEASUREMENT instrumentation and PC-based software products.

* Fault and surge/sag analysis is only available using POWER MEASUREMENT's 3720 ACM.

8.7 THIRD-PARTY SYSTEM COMPATIBILITY

3710 ACM communications uses an open protocol which supports an efficient exception reporting methodology. This allows the 3710 ACM to be easily adapted to third-party PLC, DCS, EMS, and SCADA systems. Currently, the 3710 ACM provides compatibility with the Allen-Bradley Data Highway or Modicon Modbus as options (see Sections 8.8 and 8.9).

All data and configuration registers are accessible via communications. All configuration and control operations have embedded password protection.

Contact POWER MEASUREMENT or your local POWER MEASUREMENT representative for complete documentation on the 3710 ACM communications protocol, or to discuss a specific application.

8.8 PLC/AB OPTION

8.8.1 INTRODUCTION

The PLC/AB option for POWER MEASUREMENT's 3710 ACM Digital Power Meter allows access to the *Allen-Bradley Data Highway Plus* (and *Data Highway*) through use of the Allen-Bradley Full Duplex DF1 protocol. The 3710 ACM PLC/AB emulates two commands from the PLC2 command set: Unprotected Read and Unprotected Write. The Full Duplex DF1 protocol allows information and data to be efficiently transferred between an A-B PLC and a 3710 ACM.

All data and setup parameters for the 3710 ACM (except Snapshot Log) can be accessed, as well as relay control commands.

NOTE

The PLC/AB option is *not* compatible with POWER MEASUREMENT's SCADA power monitoring software.

A 3710 ACM digital power meter with the PLC/AB option installed should also have the COMM option installed, which provides the required RS-232 or RS-485 communications port.

Mechanical mounting, electrical wiring (other than communications), and operation of units with the PLC/AB option is similar to that of the basic 3710 ACM.

Communications wiring requirements are discussed in the following section.

8.8.2 HARDWARE REQUIREMENTS AND WIRING

The 3710 ACM interfaces to the Data Highway via Allen-Bradley Communication Interface Modules. The two modules that the 3710 ACM communicates with are the *1770-KF2 Series B Communication Interface Module* and the *1785-KE Series B Data Highway Plus RS-232-C Communications Interface Module*.

Single Drop

A *single-drop* communications topology allows one 3710 ACM to be connected to the data highway via an A-B communication interface module using RS-232 communications. A direct RS-485 connection is made between the A-B interface module and the 3710 ACM. (See Figure 8.8.2).

Multi-Drop

A *multi-drop* communications topology allows you to connect up to one hundred and twenty-eight 3710 ACMs to the data highway via one A-B communication interface module using RS-485 communications. A POWER MEASUREMENT COM128 RS-232 to RS-485 Converter is required for multi-drop systems (see Figure 8.8.2).

8.8.3 COMMUNICATIONS PROTOCOL

All communications between the PLC and 3710 ACM(s) conform to a *master/slave* scheme. Information and data is transferred between a *master* PLC and *slave* 3710 ACM(s). The following message packets are supported:

READ OR WRITE SETUP

allows the PLC to read or define all the user-programmable setup parameters in the 3710 ACM (except snapshot parameters).

READ OR WRITE TIME

allows the PLC to read or define the present time and date of the 3710 ACM clock.

READ OR WRITE SETPOINTS

allows the PLC to read or define the seventeen 3710 ACM setpoint parameters.

READ LONG OR SHORT REAL-TIME DATA

allows the PLC to read detailed (long) or condensed (short) real-time data measured by the 3710 ACM.

READ STATUS

allows the PLC to read the status information on the relays, status inputs and active setpoints from the 3710 ACM.

READ EVENT OR MIN/MAX LOG

allows the PLC to read the contents of the 3710 ACM Event or Min/Max Log.

CLEAR KW HOUR OR KVAR HOUR

allow the PLC to clear the KW Hour or KVAR Hour counters of the 3710 ACM.

CONTROL RELAYS

allows the PLC to directly control the operation of the three on-board relays of the 3710 ACM.

For more information regarding operation with the A-B communications protocol, refer to the POWER MEASUREMENT document:

*3710 ACM / ALLEN-BRADLEY
SERIAL COMMUNICATIONS PROTOCOL*

Figure 8.8.2 Data Highway Single and Multi-Drop Connections

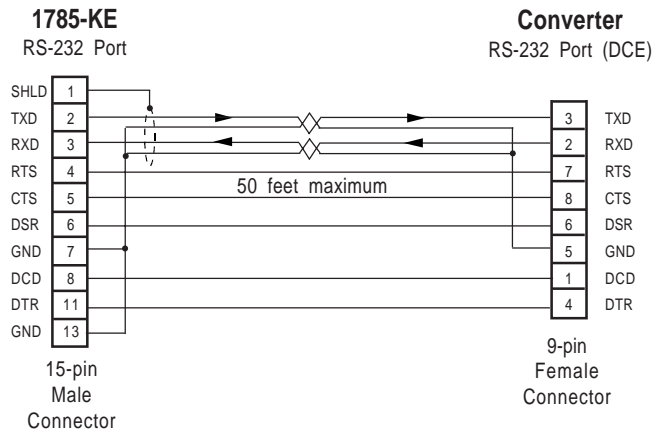
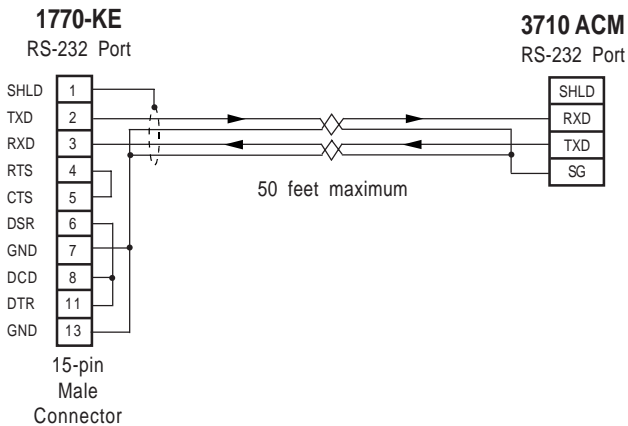
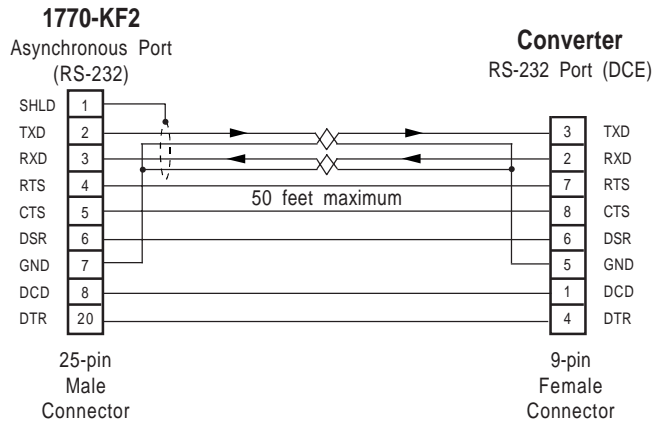
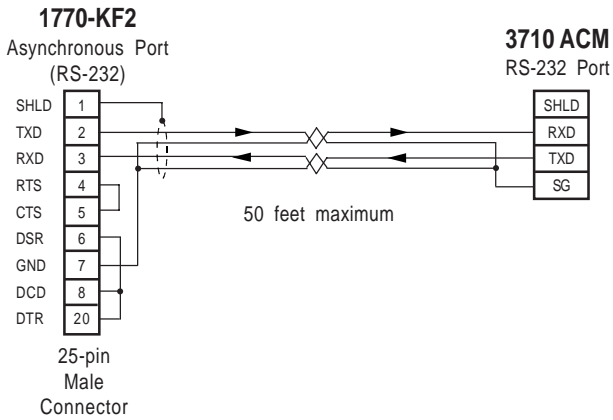
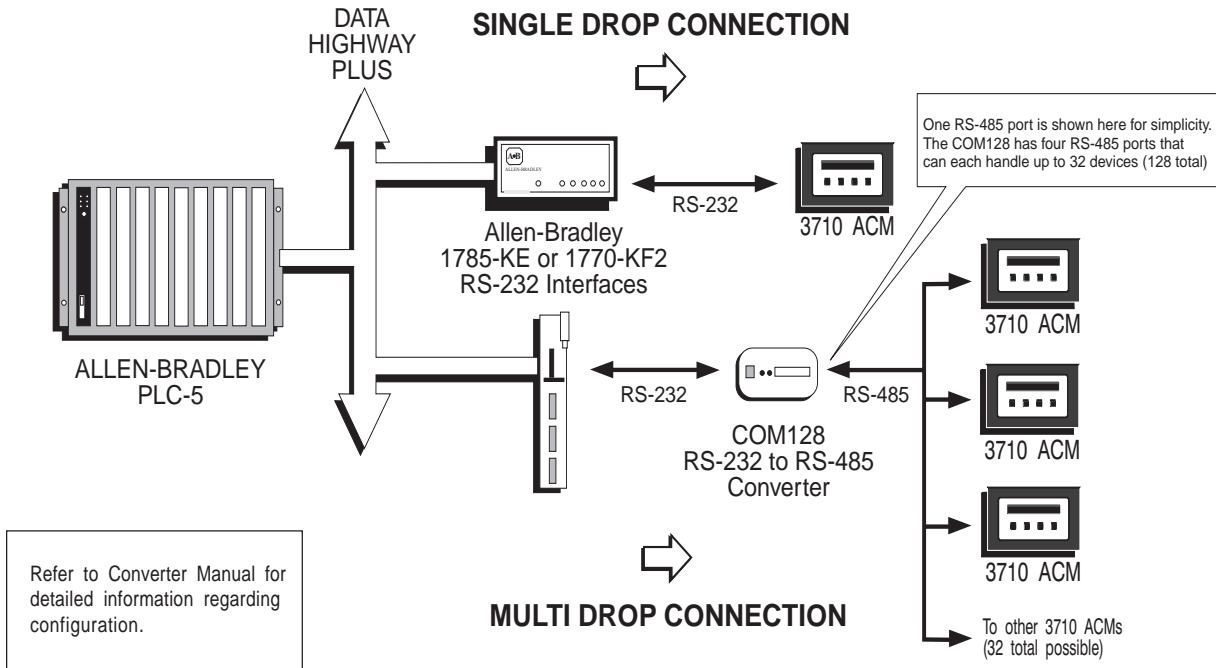

8.9 PLC/MOD OPTION

8.9.1 INTRODUCTION

The PLC/MOD option of the 3710 ACM provides compatibility with the *Modicon MODBUS* system. The Modbus communications protocol allows information and data to be efficiently transferred between a Modicon Programmable Controller and a 3710 ACM. The 3710 ACM performs Modbus communications by emulating a Modicon 984 Controller.

All 3710 ACM measured data can be accessed, including all real-time and demand values (kW, Amps or kVA). Polarity of power measurements can be determined through 3 polarity registers.

Minimum/Maximum Log values and all entries in the Event Log are also accessible, including individual time stamps. The contents of the Snapshot Log are not available.

The condition of each of the four status inputs and three relays can be read. The relays may also be controlled manually via communications.

The protocol also provides commands to initiate waveform capture and to read the sampled waveform data.

All setup parameters can be read and/or configured, including setpoint and relay setup. Password protection is provided via a special password register location.

The 3710 ACM Modbus protocol supports standard 16 bit, as well as 32 bit extended registers. 32 bit registers would typically be required only for large energy values (e.g. KWH, etc.). Register size is selectable from the front panel.

NOTE

The PLC/MOD option is not compatible with POWER MEASUREMENT'S SCADA software.

8.9.2 HARDWARE REQUIREMENTS AND WIRING

Mechanical mounting, electrical wiring (other than communications), and general operation of units equipped with the PLC/MOD option are similar to that of the basic 3710 ACM.

To use the PLC/MOD option, the 3710 ACM must also have the COMM option installed, which provides the required RS-232 or RS-485 communications port.

A Modicon BM85 Bridge/Multiplexer is required between the Modbus and Modicon Controller. An RS-232 to RS-485 converter may also be required. This is described below.

Single Drop

A *single drop* topology allows one 3710 ACM to be interfaced directly to the Modbus via its RS-232 port. Up to four 3710 ACMs may be connected to each BM85, one to each port of the Bridge/Mux. A custom cable is required between the BM85 and the 3710 ACM (see Figure 8.9.2).

Multi-Drop

A *multi-drop* topology allows up to one hundred and twenty-eight 3710 ACMs to be connected to each of the four BM85 Bridge/Mux ports. The RS-485 port of each 3710 ACM is connected on an RS-485 network that is interfaced to the Modbus via an RS-232 to RS-485 converter, such as POWER MEASUREMENT'S COM128. The COM128 allows for up to 128 power meters to be connected to each Bridge/Mux port on the BM85 (see Figure 8.9.2). The cable connecting the Bridge/Mux to the converter is a 9-pin male to 9-pin female serial cable. Refer to Section 2.6.5 for RS-485 network connections.

Figure 8.9.2 Modbus Single and Multi-Drop Connections

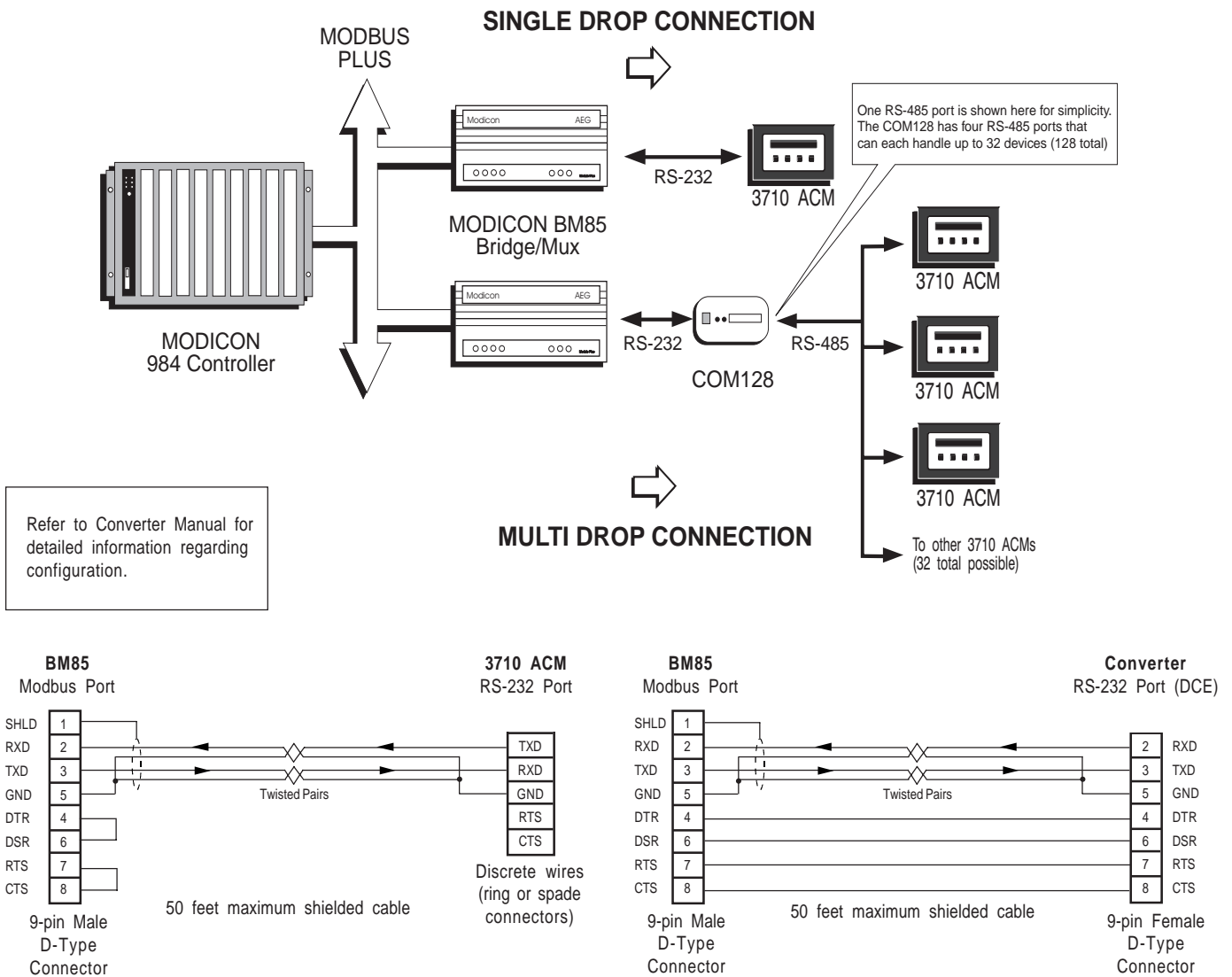

8.9.3 SETTING COMMUNICATIONS PARAMETERS

UNIT ID is set at the factory to be the last 2 digits of the unit's serial number (base 10), which can be found on the rear cover of the unit.

e.g. Unit serial number - 71317 will be preset to a UNIT ID of 17.

Communications BAUD RATE is set at the factory to 9600 baud.

The COM MODE parameter should be set according to the communications topology being used (single or multi-drop) as described earlier.

The PLC/MOD option provides an additional setup parameter named REGISTER SIZE which appears after the COM MODE in

the parameter list. This parameter determines whether a 16-bit (16 BIT) or an extended 32-bit (32 BIT) register is passed in communications for each function. The default setting is 16 BIT.

The INVALID REGISTERS parameter set to NO configures the 3710 ACM to skip all invalid registers in its Modbus register map. The next valid register will be returned in place of an invalid register.

If the INVALID REGISTERS parameter is set to YES, the 3710 ACM will return zero for all invalid registers in its Modbus register map.

The default setting is: INVALID REGISTERS = YES.

8.9.4 COMMUNICATIONS PROTOCOL

Communications occurs from the Controller via the Modbus Plus network (using MSTR block), across the BM85 to the Modbus, and on to the 3710 ACM(s) via the RS-232 / RS-485 converter (multi-drop only).

All communications between the BM85 and 3710 ACM(s) conform to a *master/slave* scheme with the BM85 as the master and the 3710 ACM(s) as slave(s).

Message Packets Supported

All registers within the 3710 ACM are accessible as PLC 4xxxx holding registers. The following Modbus commands are supported:

PRESET MULTIPLE REGISTERS (10H)

allows the Modicon Controller to define all the user-programmable setup parameters in the 3710 ACM. Registers are also provided to allow the Controller to clear the energy consumption (kWH, kVAH, kVARH) and S1 status input counter of the 3710 ACM .

READ HOLDING REGISTERS (03H)

allows the controller to read 16-bit or 32-bit real-time measured data or setup parameters from the 3710 ACM. The status of the status inputs and relays may be read, and the relays manually controlled. Registers are also provided to allow the initiation of waveform capture, and the subsequent reading of waveform capture data.

For further information regarding operation with the Modicon Modbus communications protocol, refer to the POWER MEASUREMENT document:

*3710 ACM / MODICON MODBUS
SERIAL COMMUNICATIONS PROTOCOL*

APPENDIX A

MECHANICAL & MOUNTING DIMENSIONS

BASIC MODEL

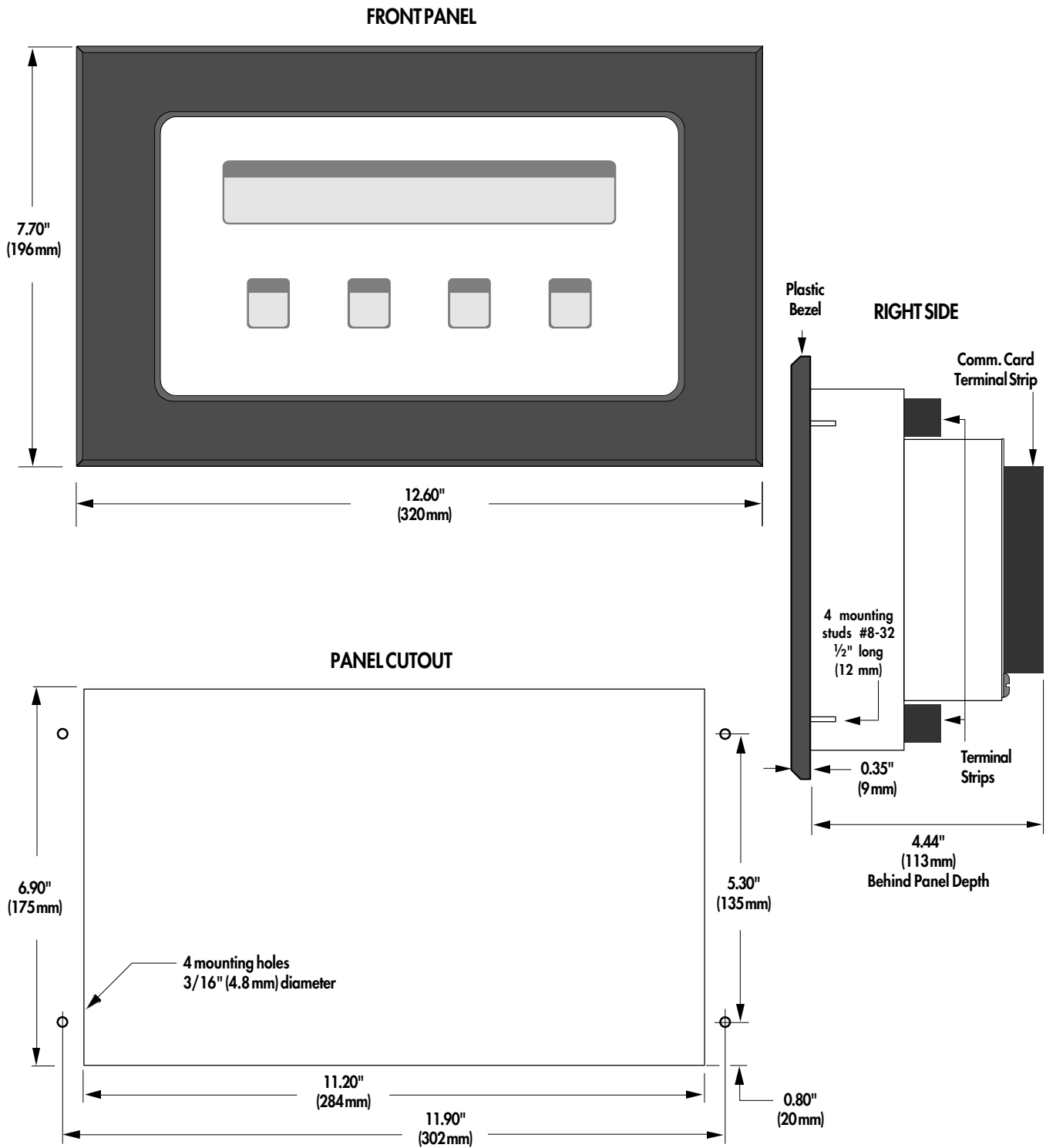

MECHANICAL & MOUNTING DIMENSIONS

TRAN MODEL

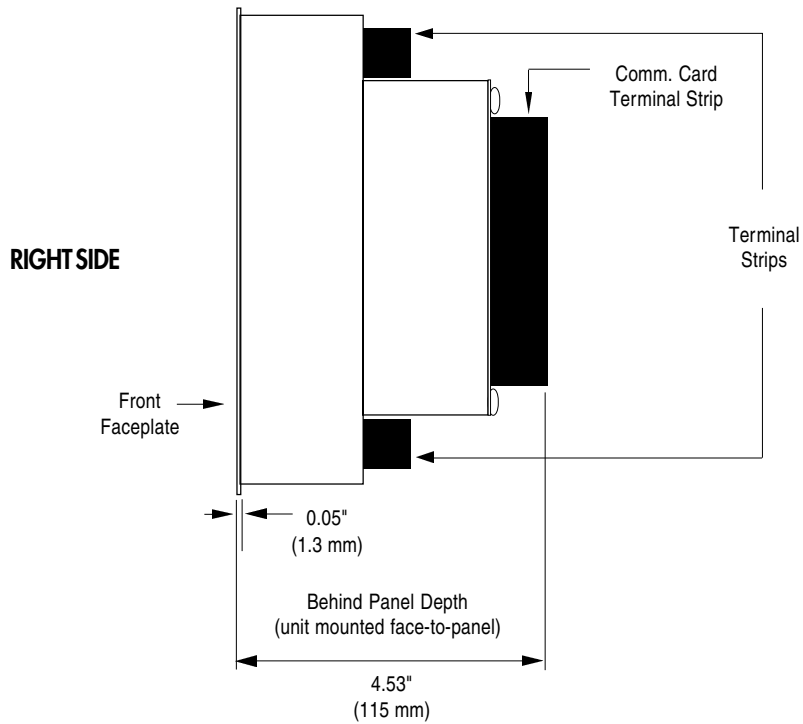
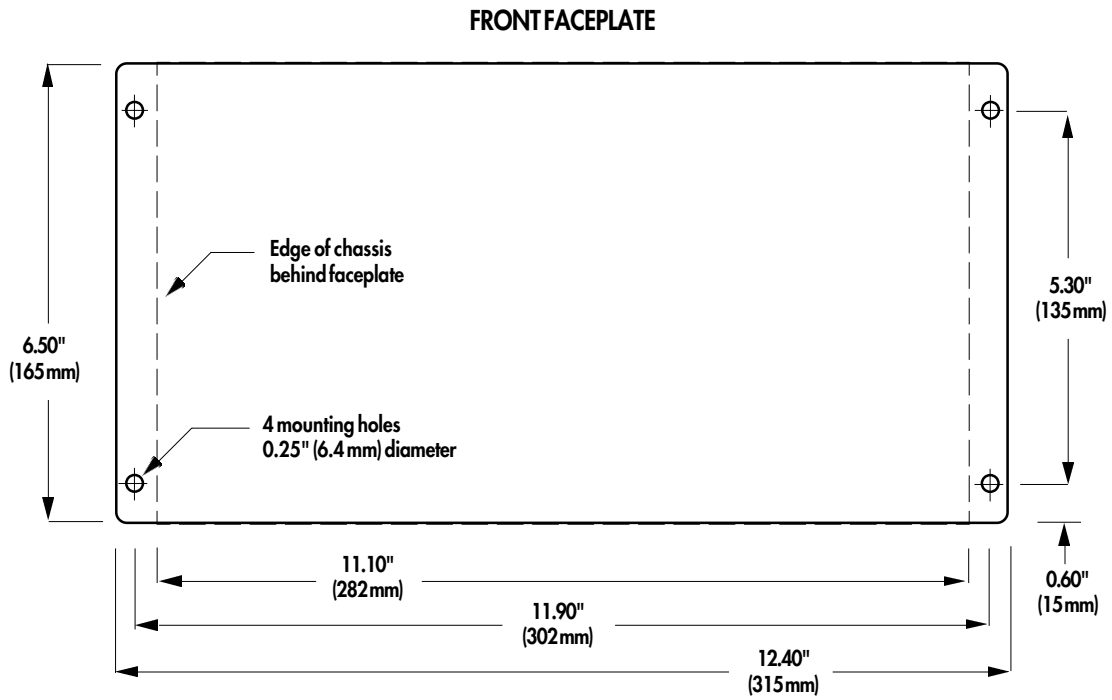

MECHANICAL & MOUNTING DIMENSIONS

TERMINAL BLOCK DIMENSIONS

NOTE
Rear panel of basic model is shown. For TRAN model, disregard edge of front bezel.

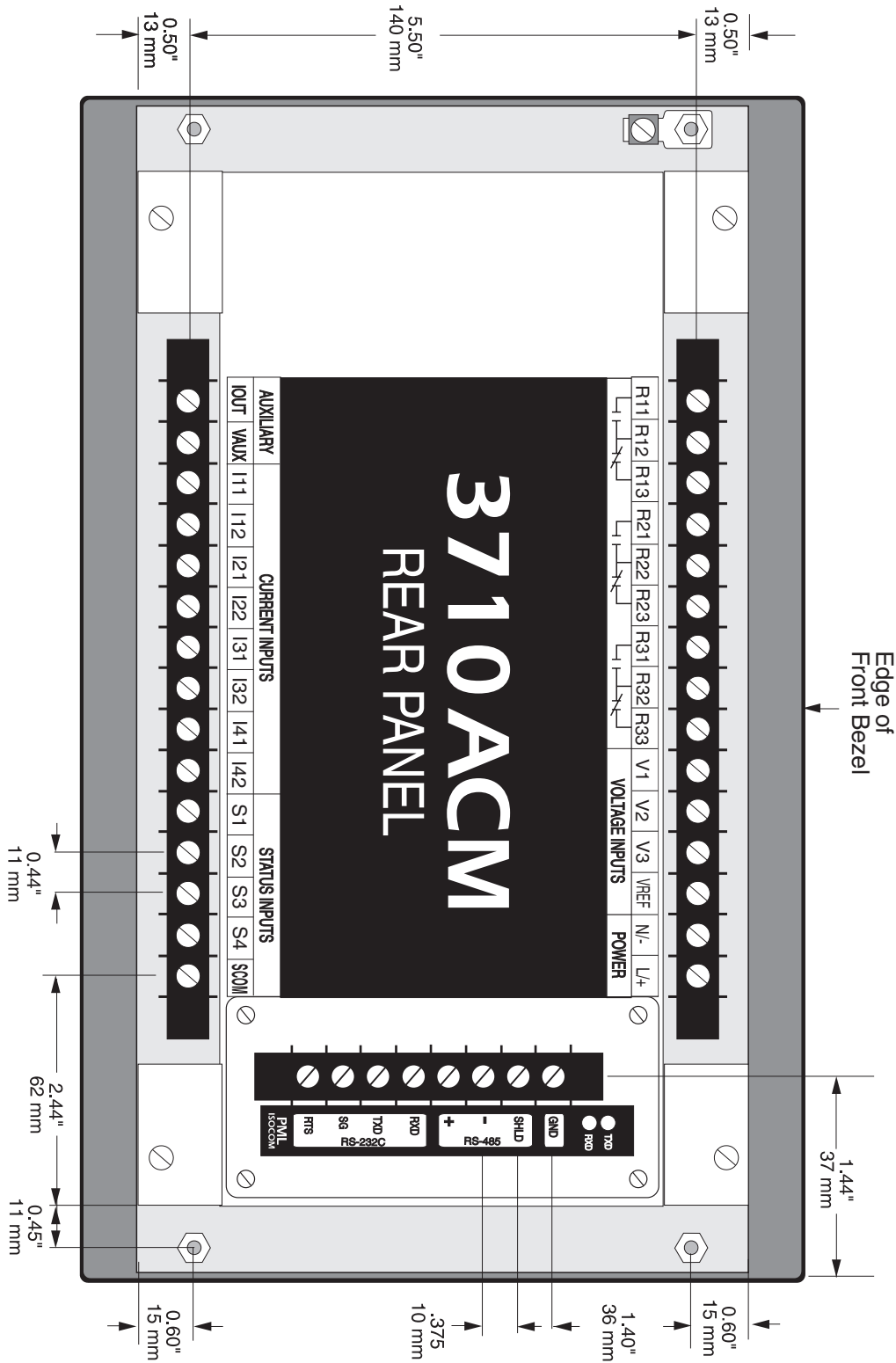

APPENDIX B

SETPOINT PARAMETER FORM

SETPOINT	TRIGGER PARAMETER	HIGH LIMIT	LOW LIMIT	TD OPERATE	TD RELEASE	ACTION
SP1						
SP2						
SP3						
SP4						
SP5						
SP6						
SP7						
SP8						
SP9						
SP10						
SP11						
SP12						
SP13						
SP14						
SP15						
SP16						
SP17						

APPENDIX C

FIRMWARE VERSIONS

This following table lists each firmware version release for the 3710 ACM and the new features or performance enhancements added with each release.

The version number can be viewed from the front panel in programming mode. If your 3710 ACM is currently using a firmware version older than the most recent version listed in the table below, you may upgrade the firmware in that unit by contacting your local representative or the manufacturer.

Either contact will need to know the serial number of the 3710 ACM and the firmware version number indicated on the rear cover label.

Most upgrades to the 3710 ACM will require a simple replacement of the EPROM integrated circuit (IC) inside the unit which contains the operating firmware. Some upgrades may require replacement of other ICs as well. Complete instructions for this procedure are provided with the replacement IC(s).

VERSION	RELEASE DATE	DESCRIPTION
V 2.0.X.X	October 1989	Initial release.
V 2.1.X.X	August 1990	Adds 400 Hz standard frequency capability. Adds DECREMENT key function. Adds display test feature. Adds I4 independent scaling.
V 2.2.X.X	August 1991	Adds Bidirectional KWH and KVARH readings. Improved Power Factor indication. Adds Relay Pulse Mode. Adds 4-wire Wye: 2½ Element Mode. Added KVARH-R (Reverse) setpoint. Added Waveform Capture capabilities. Demand Period now internally synchronized to time set via communications port. "INVALID ENTRY" feature added to Program Mode. Added user-definable Phase labels and numeric format. Extended AMPS SCALE range to 30,000. VOLTS MODE and IOU RANGE number codes replaced by descriptive labels. Added RTS line control in RS-232 communications mode.
V 2.3.X.X	January 1992	Adds status input setpoint types
V 3.0.X.X	December 1992	Adds kVAH measurement.

APPENDIX D

TECHNICAL SPECIFICATIONS

PARAMETER	ACCURACY ³ (% of full scale)	FRONT PANEL DISPLAY	
		Resolution	Range
Voltage	0.2 %	0.1 %	0 - 999,999 ¹
Current	0.2 %	0.1 %	0 - 30,000
I4	0.2 %	0.1%	0 - 9,999
Vaux	0.25 %	0.1%	0 - 999,999
kW	0.4 %	0.1%	0 - 999,999 ²
kVAR	0.4 %	0.1%	0 - 999,999 ²
kVA	0.4 %	0.1%	0 - 999,999 ²
kWH	0.4 %	1 kWH	0 - 999,999,999
kVARH	0.4 %	1 kVARH	0 - 999,999,999
kVAH	0.4 %	1 kVAH	0 - 999,999,999
Power Factor	1.0 %	1.0 %	-0.6 to 1.0 to +0.6
Frequency	0.2 Hz	0.1 Hz	40 to 450 Hz

NOTES:

1. Reads in kV for voltages over 9,999
2. Reads in MVA, MW, MVAR for readings over 9,999k
3. @50.0 Hz or @60.0 Hz @ 25°C (77°F)



WAVEFORM CAPTURE

Sampling Rate: approx. 130 microseconds (128 times per 60 Hz cycle) Accuracy: 2% of full scale Resolution: 10 bits (0.1 %)

... see overleaf for INPUT & OUTPUT RATINGS

APPENDIX D

TECHNICAL SPECIFICATIONS

INPUT & OUTPUT RATINGS	
Voltage Inputs:	<p>Basic Model: 120 VAC nominal full scale input.</p> <p>277 Option: 277 VAC nominal full scale input.</p> <p>347 Option: 347 VAC nominal full scale input.</p> <p>Overload withstand for all options: 1500 VAC continuous, 2500 VAC for 1 second.</p> <p>Input impedance for all options: 2 Megohm</p>
Current Inputs:	<p>Basic Model: 5.000 Amps AC nominal full scale input.</p> <p>Overload withstand for all options: 15 Amps continuous, 300 Amps for 1 sec.</p> <p>Input impedance: 0.002 ohm, Burden: 0.05 VA</p>
Aux. Voltage Input:	<p>1.0 VAC/VDC nominal full scale input (1.25 VAC /VDC max.)</p> <p>Overload withstand: 120 VAC/VDC continuous, 1000 VAC/VDC for 1 second.</p> <p>Input impedance: 10 Kohm</p>
Control Relays:	<p>Basic Model: Form C dry contact. 277 VAC / 30 VDC @ 10 Amp resistive</p> <p>SSR Option: SPST solid state. 24 to 280 VAC (use AC only) @ 1 Amp resistive</p>
Aux. Current Output:	<p>0 to 20 mA into max. 250 ohm load. Accuracy: 2%</p>
Status Inputs:	<p>Basic Model (<i>external excitation</i>): S1, S2, S3, S4: >20 VAC/VDC = active, <6 VAC/VDC = inactive, Min. Pulse Width: 40 msec. Input impedance: 49.2 Kohm, Overload withstand: 1500 V continuous, 2500 V for 1 sec.</p> <p>SES Option (<i>self-excitation</i>): +30 VDC differential SCOM output to S1, S2, S3, or S4 input. Min. Pulse Width: 40 msec.</p>
Power Supply:	<p>Basic Model: 85 to 132 VAC / 0.2 Amps / 47 to 440 Hz or 110 to 170 VDC / 0.2 Amps</p> <p>P240 Option: 85 to 264 VAC / 0.2 Amps / 47 to 440 Hz or 110 to 340 VDC / 0.2 Amps</p> <p>P24/48 Option: 20 to 60 VDC @ 10 W</p>
Operating Temperature:	<p>Basic Model: 0°C to 50°C (32°F to 122°F) ambient air.</p>
Storage Temperature:	<p>-30°C to +70°C (-22°F to +158°F)</p>
Humidity:	<p>5 to 95 %, non-condensing</p>
Shipping:	<p>Weight: 3.9 kg (8lbs. 10 oz.) Carton: 38 x 25 x 18 cm (15" x 9.8" x 7.1").</p>
<p>Voltage, Current, Status, Relay and Power inputs all pass the ANSI/IEEE C37.90A-1989 surge withstand and fast transient tests.</p>	
<div style="display: flex; justify-content: space-around; align-items: center;"> <div style="text-align: center;">  <p>E95810</p> </div> <div style="text-align: center;">  <p>LR 57329</p> </div> </div>	

APPENDIX E

MODEL/ORDERING INFORMATION

MODEL & STANDARD FEATURES:

(X = included O = not included)

MODEL	Comm. Card	Relays	Status Inputs	Logs	Aux. Output	Aux. Input	120 VAC Inputs	Vac.Fluor. Display
3710ACM	O	X	X	X	X	X	X	X
3710ACM-DISPLAY	O	O	O	O	O	X	X	X
3710ACM-TRAN	X	X	X	X	X	X	X	O

OPTIONS¹:

SUFFIX	DESCRIPTION
COMM ^{2, 3}	Combination RS-232/RS-485 plug-in communications card
PLC/MOD ⁴	Modicon Modbus communications protocol (instead of POWER MEASUREMENT protocol)
PLC/AB ⁴	Allen-Bradley communications protocol (instead of POWER MEASUREMENT protocol)
KVD	Replaces Amp Demand parameter with kVA Demand if unit is equipped with POWER MEASUREMENT protocol
MDK ⁴	Replaces Amp Demand parameter with kVA Demand if unit is equipped with the PLC/MOD option
277	To monitor 277/480 VAC systems (instead of 120/208 VAC)
347	To monitor 347/600 VAC systems
SSR	SPST solid state relays (instead of Form-C dry contact electromechanical)
P24/48	20 to 60 VDC powered (instead of 85-132 VAC/VDC)
P240	85-264 VAC @ 47-440 Hz or 110-300 VDC powered
SES	Self-excited status inputs. Note: Internal 30 VDC supply. Can be used for contact sensing applications only (see Chapter 2)
TROP	Tropicalization (conformal coating) treatment
RACK	19 inch rack mount enclosure

NOTES:

1. Desired options must be specified when ordering.
2. The 3710 ACM model can be field upgraded to provide RS-485/RS-232 communications capability by ordering the COMM communications card separately. The COMM option is not available for 3710ACM-DISPLAY model.
3. The COMM option is required to interface to POWER MEASUREMENT's SCADA power monitoring systems.
4. PLC/MOD and PLC/AB options are not compatible with POWER MEASUREMENT's SCADA systems.

APPENDIX F

WARRANTY AND REGISTRATION

WARRANTY

This product is warranted against defects in materials and workmanship for three years. The Warranty is effective from date of purchase. POWER MEASUREMENT LIMITED will repair or replace, at its option, any product found to be defective (F.O.B. point of manufacture) during the Warranty period, provided the equipment has been installed, wired, programmed, and operated in accordance with the manufacturer's instruction manual included with each unit, and the applicable sections of the Electrical Code.

The Warranty will be invalid if any unauthorized alterations are made to the product, or if the product has been abused or mishandled. Damage due to static discharges will void the Warranty, as will application of voltages or currents outside the specified ratings of the device inputs.

EXCEPT TO THE EXTENT PROHIBITED BY APPLICABLE LAW, NO OTHER WARRANTIES, WHETHER EXPRESSED OR IMPLIED, INCLUDING WARRANTIES OF MERCHANTABILITY AND FITNESS FOR A PARTICULAR PURPOSE, SHALL APPLY TO THIS PRODUCT; UNDER NO CIRCUMSTANCES SHALL POWER MEASUREMENT LIMITED BE LIABLE FOR CONSEQUENTIAL DAMAGES SUSTAINED IN CONNECTION WITH SAID PRODUCT AND POWER MEASUREMENT LIMITED NEITHER ASSUMES NOR AUTHORIZES ANY REPRESENTATIVE OR OTHER PERSON TO ASSUME FOR IT ANY OBLIGATION OR LIABILITY OTHER THAN SUCH AS IS EXPRESSLY SET FORTH HEREIN.

PRODUCT RETURN PROCEDURE

The following procedure must be strictly adhered to when returning any POWER MEASUREMENT product to the factory for the purpose of repair, replacement, credit, upgrade, recalibration, or for any other reason.

1. Contact POWER MEASUREMENT or your local POWER MEASUREMENT Sales Representative and obtain a *Return Merchandise Authorization* (RMA) number prior to shipment of any unit back to the manufacturer. Be prepared to provide the product's model number, serial number, and the reason for returning the unit. **Units received without prior authorization will not be accepted under any circumstances.**
2. If the unit is being returned for repair, replacement, or upgrade a *product return report* should be completed and included with the unit. The information provided should include:
 - A functional description of the unit defect or failure and the electrical/environmental conditions at the

time of failure. This will significantly reduce repair/upgrade time (and cost, if warranty has expired). If the unit is being returned for an upgrade, recalibration or other modification, list the requirements.

- The RMA number issued by POWER MEASUREMENT, the serial number of the unit, the company name and address, the name of the person filling out the report, and the date.
 - **IMPORTANT: The return address to which the unit is to be shipped following servicing.**
3. Pack the unit safely, preferably in the original shipping carton, and include the detailed report described above. **The RMA number must be clearly marked on the outside of the box.**
 4. A packing slip must be attached to the outside of the box which includes the points of origin and destination, a description of contents, and the reason for return. Examples: *For Repair and Return*, or *Returned for Credit*. There should be no need to declare a value.
 5. Ship PREPAID to the appropriate address below. POWER MEASUREMENT will not accept C.O.D. shipments. If the unit is still under warranty, POWER MEASUREMENT will pay the return shipping charges.

For Shipments Originating in the U.S.A.:

Power Measurement Ltd.
c/o VICTORIA CUSTOMS BROKERS
4131A Mitchell Way
Bellingham, WA 98226

For Shipments Originating Overseas:

Power Measurement Ltd.
c/o LIVINGSTON VICTORIA CUSTOMS BROKERS
Box 124, 1640 Electra Boulevard
Sidney, BC, CANADA
V8L 5V4

For Shipments Originating in Canada:

Power Measurement Ltd.
2195 Keating Cross Road,
Saanichton, BC, CANADA
V8M 2A5

REGISTRATION

Please complete and mail the enclosed *Warranty Registration* card immediately. This will allow us to add you to our mailing list, to keep you up to date on the latest product firmware releases and new feature offerings.

Your comments and suggestions for product improvement and feature additions are welcome.

APPENDIX G

TROUBLESHOOTING

A number of problems can cause the 3710 ACM not to function properly. This chapter lists a number of symptoms, and explains how to correct them.

1. If the display does not operate:
 - a) check that there is at least 110 volts available to the power supply (L and N connections on the terminal strip).
 - b) confirm that the Chassis Ground Lug terminal is connected directly to ground.

If the above steps do not solve the problem, perform the following:

- a) As a diagnostic test, turn the unit off (disconnect power) for at least ten seconds. Apply power again and check if the unit powers up correctly.
 - b) Contact POWER MEASUREMENT or your local POWER MEASUREMENT representative and report the problem and results of the test.
2. If the voltage or current readings are incorrect:
 - a) check that the voltage mode is properly set for the given wiring.
 - b) check that the voltage and current scales are properly set.
 - c) make sure the Chassis Ground Lug terminal is properly grounded.
 - d) check the quality of the CT's and PT's being used.
 - e) make the following voltage tests:
 - i) V1, V2, V3 to VREF should be 120 VAC (for the voltage inputs of the basic model). This will be dependent on the voltage input option installed.
 - ii) Chassis Ground Lug to switchgear earth ground should be 0 V.

3. If the kW or Power Factor readings are incorrect but voltage and current readings are correct, make sure that the phase relationship between voltage and current inputs is correct by comparing the wiring with the appropriate wiring diagram. Note that POWER MEASUREMENT's PC-based SCADA software can be used to verify PT and CT sequence and polarity by analysing the captured voltage and current waveforms for each phase.
4. If RS-232 or RS-485 communication does not work:
 - a) check that the baud rate of the host computer /PLC is the same as that of the 3710 ACM.
 - b) check that the communications mode (RS-232 or RS-485) set by the jumper on the communications card is correct for the type of standard being used (see Chapter 2, Section 2.6.2).
 - c) check all communications wiring (see Chapter 2, Figures 2.6.4 to 2.6.6).
 - d) check that the number of data bits is set to 8, with one stop bit and no parity.

If the above steps do not solve the problem, perform the following:

- a) As a diagnostic test, turn both the 3710 ACM off (disconnect power) and the computer off for at least ten seconds. Apply power again and check if the communications operate successfully.
- b) Contact POWER MEASUREMENT or your local POWER MEASUREMENT representative and report the problem and results of the test.

If the symptom persists after performing the specified steps, or if the symptom is not listed above, contact your local POWER MEASUREMENT representative or the technical support / customer service department of POWER MEASUREMENT (see the front of this manual).

