

CHAPTER 1—INTRODUCTION

WHAT IS THE POWER METER?

The POWERLOGIC® Power Meter is a compact, low-cost power meter for basic industrial power monitoring applications. The power meter has been designed for ease of installation in industrial retrofit applications. Power meter applications include new equipment such as switchboards, panelboards, and Low Voltage Drawout (LVDO) feeders, and it can be used in POWERLINK installations for metering the main. Additionally, the power meter can be used for Motor Control Centers (MCCs) and busway.

The power meter can be purchased with an optional display for local display and setup. Also, the display can be purchased separately to be used as a power meter programmer. The display fits standard 4-1/4" (108 mm) ammeter and voltmeter cutouts. It connects to the power meter by a cable that supplies both communications and power.

All power meter modules can be mounted up to 50 feet (15.2 m) from the display. You can mount them on an enclosure floor or wall, on a horizontal 35 mm DIN rail, or directly behind the display on the panel door.

The power meter is completely supported in POWERLOGIC System Manager Software releases SMS-3000, SMS-1500 and PMX-1500, including setup and resets. SMS-770/700 v. 2.23 and EXP-550/500 v. 1.23 provide limited support, including real-time and historical data monitoring and PC-based alarming and trending.

Some of the power meter's features include:

- ANSI C12.16 Revenue Accuracy
- True RMS Metering (31st Harmonic)
- Accepts Standard CT and PT Inputs
- Direct Connect up to 600 V
- Fits Standard 1% Ammeter/Voltmeter Mounting Holes
- Optional Display to View Meter Values
- Power Quality Readings—THD (Voltage and Current)
- On-board Clock/Calendar
- Easy Setup through Remote Display (Password Protected)
- RS-485 Communications Standard
- System Connections
 - 3-Phase, 3-Wire Delta (Metered or Calculated B Phase)
 - 3-Phase, 4-Wire Wye
- Operating Temperature Range (0°C to +60°C)

Table 1-1 below summarizes the power meter instrumentation common to all three models. Table 1-2 describes the three power meter models and accessories. You can assemble custom length cables using the components specified in Table 1-3. Table 1-4 compares features of those models.

Table 1-1

Summary of Power Meter Instrumentation

<p>Real-Time Readings</p> <ul style="list-style-type: none"> • Current (per phase) • Voltage (L-L, L-N) • Real Power (per phase and 3Ø total) • Reactive Power (per phase and 3Ø total) • Apparent Power (per phase and 3Ø total) • Power Factor, true (per phase, 3Ø) • Frequency
<p>Energy Readings</p> <ul style="list-style-type: none"> • Accumulated Energy, real 3Ø total • Accumulated Energy, reactive 3Ø total • Accumulated Energy, apparent 3Ø total

Table 1-2

Class 3020 Power Meters and Accessories

Type	Description
PM-600	Instrumentation, 0.3% accuracy
PM-620	PM-600 features, plus date/time stamp, THD/thd, neutral current, demand values
PM-650	PM-620 features, plus alarms, min/max values, data and event logs
PMD-32	Power Meter Display (optional) with 1-ft. (0.3 m) cable
SC-104	4-ft. (1.2 m) cable (optional)
SC-112	12-ft. (3.7 m) cable (optional)
SC-130	30-ft. (9.1 m) cable (optional)

Table 1-3

Components for Assembling Custom Length Cables

Description	Mfr./Part Number	Quantity
RJ-11, 6-position, 4-conductor ① Round Cable Modular Plug	Mouser 154-UL6234 or AMP 5-569031-3	2 plugs
Signal and Control Cable	Olflex 602604 or Unitronic 190 (4-wire/26 AWG)	50-ft. (15.2 m) Maximum Length

① Assemble with manufacturer's recommended crimping tool.

Table 1-4
Power Meter Feature Comparison

Feature	PM-600	PM-620	PM-650
Full Instrumentation	X	X	X
RS-485 Communications Port	X	X	X
Wiring Diagnostics	X	X	X
ANSI C12.16 Accuracy	X	X	X
Current Demand (per phase, neutral)		X	X
Power Demand (3-phase total, present)		X	X
Peak Power & Current Demand		X	X
Date/Time Stamping		X	X
THD or thd (Voltage and Current)		X	X
Calculated Neutral Current		X	X
Onboard Alarms			X
Min/Max Readings			X
Predicted Power Demand			X
Data Log			X
Event Log			X
Demand Interval Synch to Comms			X
Rolling Block Demand			X

USING THIS BULLETIN

This document provides the information required to install and operate the power meter. The document consists of a table of contents, chapters, several appendices, and an index. To locate information on a specific topic, refer to the table of contents or the index.

Notational Conventions

This document uses the following notational conventions:

- **Procedures.** Each procedure begins with a statement of the task, followed by a numbered list of steps. Procedures require you to take action.
- **Bullets.** Bulleted lists, such as this one, provide information but not procedural steps. They do not require you to take action.
- **Cross-References.** Cross-references to other sections in the document appear in boldface. Example: see **Power Meter Connections** in **Chapter 3**.

Not Covered in this Bulletin

Some of the power meter's features, such as PC-based logging, onboard logging for the PM-650, trending, and PC-based alarming, must be set up using POWERLOGIC application software. For instructions on setting up these features, refer to the application software instruction bulletin.

Note: The PM-650 is supported by POWERLOGIC System Manager Software (SMS)-3000 v. 3.1 (and higher).

CHAPTER 2—SAFETY PRECAUTIONS



DANGER

HAZARD OF ELECTRIC SHOCK, BURN, OR EXPLOSION.

- Only qualified electrical workers should install this equipment. Such work should be performed only after reading this entire set of instructions.
- The successful operation of this equipment depends upon proper handling, installation, and operation. Neglecting fundamental installation requirements may lead to personal injury as well as damage to electrical equipment or other property.
- Before performing visual inspections, tests, or maintenance on this equipment, disconnect all sources of electric power. Assume that all circuits are live until they have been completely de-energized, tested, grounded, and tagged. Pay particular attention to the design of the power system. Consider all sources of power, including the possibility of backfeeding.

Failure to observe these precautions will result in death, severe personal injury, or equipment damage!

CHAPTER 3—HARDWARE DESCRIPTION

DISPLAY

The optional power meter display is designed for maximum ease of use. The display has the following modes of operation:

- Setup—for setting up power meter
- Resets—to perform resets of peak demands^①, accumulated energy, and min/max^②
- Diagnostics—for troubleshooting, read-only registers
- Summary—displays commonly viewed metered values
- Power—displays power values
- Energy—displays energy values
- Demand^①—displays demand values
- Power Quality^①—displays power quality values
- Alarm Log^②—displays and acknowledges onboard alarms
- Alarm Setup^②—for setting up onboard alarms
- Min/Max^②—displays minimum and maximum values

For details on how to use the optional display, see **Chapter 7—Display Operation**.

^① When used with PM-620 and PM-650.

^② When used with PM-650.

Figure 3-1 shows the power meter display. Display components are listed below:

- ① **2-Line Liquid Crystal Display.** For local display of metered values.
- ② **Arrow Buttons.** Press to move through meter display screens. In Setup, Resets, and Diagnostic modes, press to change values and, on the PM-650 only, Alarm Setup and Alarm Log.
- ③ **Mode Button.** Press to scroll through the available modes.
- ④ **Contrast Button.** Press to change the contrast of the display.
- ⑤ **Select Button.** Press to select modes and Setup, Resets, and Diagnostic values. On the PM-650 only, use this button to select Alarm values.

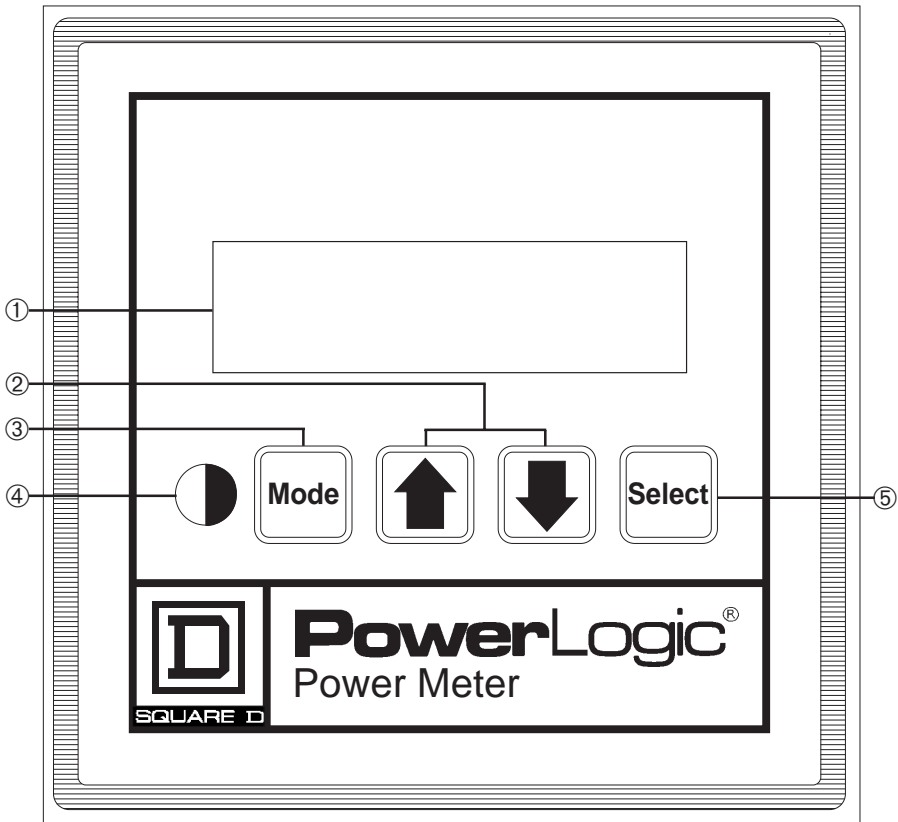

Figure 3-1: Power meter display components

The display connects to the power meter via the display cable. One display communications port is located on the back of the display (figure 3-2, below). The other display communications port is located on the meter connections end of the power meter (figure 3-3).

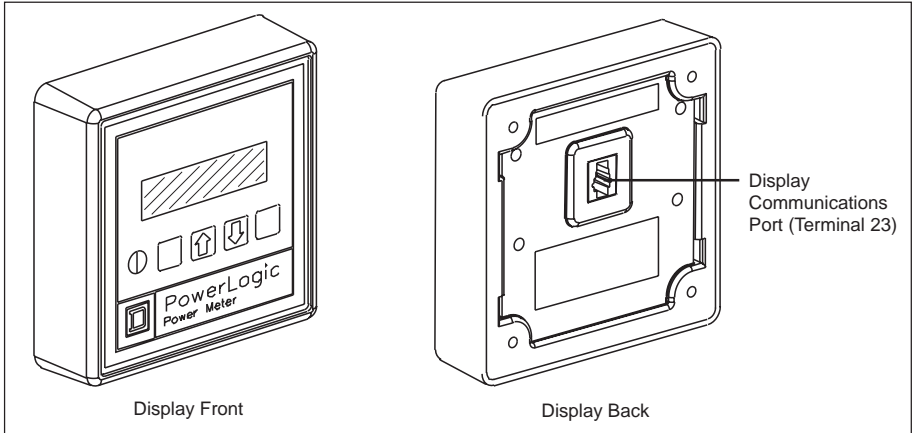

Figure 3-2: Power meter display, front and back

POWER METER CONNECTIONS

Figure 3-3 shows the front of the power meter and the label on the terminal shield. Identified parts are as follows:

- ① 3-Phase Voltage Inputs
- ② Control Power Terminals
- ③ KYZ Pulse Output
- ④ 3-Phase Current Inputs
- ⑤ Display Communications Port
- ⑥ RS-485 Communications Terminals

Note: See Chapter 5—Wiring for wiring instructions.

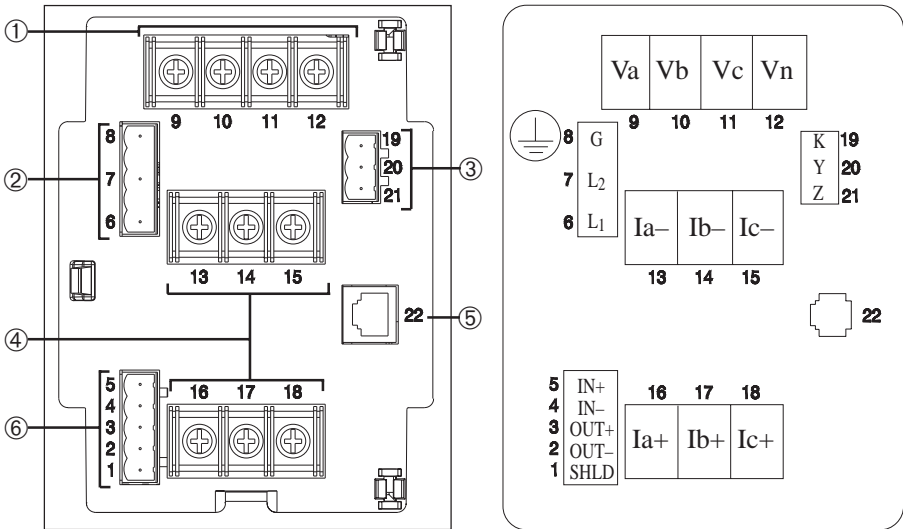

Figure 3-3: Front of power meter and terminal shield label

CHAPTER 4—INSTALLATION

DANGER

HAZARD OF ELECTRIC SHOCK, BURN, OR EXPLOSION.

Only qualified electrical workers should install and wire this equipment. Perform such work only after reading this complete set of instructions.

Failure to observe these precautions will result in death or severe personal injury!

CAUTION

HAZARD OF EQUIPMENT DAMAGE.

When mounting the power meter module, provide the following clearances (from enclosure walls or other objects): terminal end: 4" (102 mm); vented sides: 3" (76 mm). No clearance is necessary on the non-vented sides.

Failure to observe this precaution can result in equipment damage.

POWER METER/DISPLAY MOUNTING OPTIONS

There are several options for mounting the power meter module and display:

- display mounted on front of a power equipment panel; power meter module mounted on back of panel (figure 4-1, page 15)
- display mounted on front of panel; power meter mounted remotely inside of equipment, with the terminals
 - up, mounted to bottom (floor) of equipment, or
 - perpendicular, mounted on side pan (figure 4-2, page 17)
- display mounted on front of panel, with the power meter module mounted on a 35 mm DIN rail (figure 4-4, page 19)
- no display; power meter mounted in one of the above locations

Mounting instructions for each of these options are described in this section.

When choosing a mounting location, consider the following:

- Allow for easy access to the meter connections end (where terminals are located) of the power meter module.
- Allow extra space for all wires, shorting blocks, or other components.

- Be sure that ambient conditions fall within the acceptable range: operating temperature 0°C to +60°C, relative humidity 5–95%, non-condensing.

Note: Always refer to local and state electrical safety standards before mounting the power meter or display.

MOUNTING THE DISPLAY

The display can be mounted in the following locations:

- in a standard 1% ammeter/voltmeter panel cutout
- on an equipment panel where it will be necessary to cut a hole before mounting the display

Table 4-1 below shows possible locations for mounting the display.

Table 4-1
Typical Locations for Mounting Display

Equipment Type	Mounting Location
QED Switchboards	Disconnect Door
POWER-ZONE® III Switchgear	Main Instrument Compartment Door
HVL and VISI/VAC® Switchgear	9-inch Front Panel or Instrument Door
Metal-Clad and Substation CBs	Standard Relaying Locations
ISO-FLEX® Medium Voltage MCCs	Low Voltage Door
Model 6 MCCs	Main Meter Location or Auxiliary Section

In Existing 1% Ammeter/Voltmeter Cutout

To mount the display in a standard 1% ammeter/voltmeter cutout, follow these steps:

1. Turn off all power supplying the equipment before working on it. Follow all safety precautions, remove the existing ammeter/voltmeter.
2. Position the display against the front of the panel. From the other side of the panel, line up the mounting holes in the panel with the mounting holes in the display (see figure 4-1, page 15).



CAUTION

HAZARD OF EQUIPMENT DAMAGE.

Use only the power meter display mounting screws included in the mounting hardware kit. Use of any other screws for display mounting voids the warranty and may damage the display.

Failure to observe this precaution can result in equipment damage.

- 3a. **If a power meter will be attached to the display**, insert display mounting screws into only the top two holes; tighten until approximately 1/4" of each screw protrudes from the panel. See **Directly Behind the Display**, page 14, for remaining instructions. Begin with step 3.
- b. **If a power meter will not be attached directly to the display** (behind the panel door), insert one display mounting screw (included in hardware kit) through each of the four mounting holes. Tighten all screws to 6–9 lb-in (0.7–1.0 N•m).

On Panel Without Existing 1% Ammeter/Voltmeter Cutout

To mount the display on a panel without an existing cutout for an ammeter/voltmeter, follow these steps:

1. Turn off all power supplying the equipment before working on it. Follow all safety precautions.
 2. Tape the template shipped with the display to the panel in the desired location; make sure the template is level. (Hole positions and dimensions are shown in figure 4-3, page 17.) Make sure no wires or equipment on the other side of the panel will be damaged, then drill through the panel at the 4 holes marked *A* on the template. Use a 3/16" drill bit.
 3. Drill or punch a hole 2 to 4 inches (51–102 mm) in diameter through the panel at the center of the template (center of hole is marked on the template).
 4. Position the display against the front of the panel. From the other side of the panel, line up the mounting holes in the panel with the mounting holes in the display.
- 5a. **If a power meter will be attached directly to the display**, insert screws into only the top two holes; tighten until approximately 1/4" of each screw protrudes from the panel. See **Directly Behind the Display**, page 14, for remaining instructions. Begin with step 3.



CAUTION

HAZARD OF EQUIPMENT DAMAGE.

Use only the power meter display mounting screws included in the mounting hardware kit. Use of any other screws for display mounting voids the warranty and may damage the display.

Failure to observe this precaution can result in equipment damage.

- b. **If a power meter will not be attached directly to the display** (behind the panel door), insert one display mounting screw (included in hardware kit) through each of the four mounting holes. Tighten all screws to 6–9 lb-in (0.7–1.0 N•m). *Note:* See *CAUTION* statement above.

MOUNTING THE POWER METER

Power meter mounting options are described in this section.

DANGER

HAZARD OF ELECTRIC SHOCK, BURN, OR EXPLOSION.

Only qualified electrical workers should install and wire this equipment. Perform such work only after reading this complete set of instructions.

Failure to observe these precautions will result in death or severe personal injury!

CAUTION

HAZARD OF EQUIPMENT DAMAGE.

When mounting the power meter module, provide the following clearances (from enclosure walls or other objects): terminal end: 4" (102 mm); vented sides: 3" (76 mm). No clearance is necessary on the non-vented sides.

Failure to observe this precaution can result in equipment damage.

Directly Behind the Display

To mount the power meter directly behind the display, follow these steps:

1. Turn off all power supplying the equipment before working on it. Follow all safety precautions.
2. Mount the display. See **Mounting the Display**, page 12, for instructions.
3. Plug one end of the 1-foot communications cable provided with the display into the display communications port (terminal 23, figure 4-1) on the back of the display.
4. Hook the power meter mounting feet onto the top two display mounting screws protruding from the back of the door or panel. Route the cable to the right (hinged side) so it is not pinched between the power meter module and the panel (figure 4-1).



CAUTION

HAZARD OF EQUIPMENT DAMAGE.

Use only the power meter display mounting screws included in the mounting hardware kit. Use of any other screws for display mounting voids the warranty and may damage the display.

Failure to observe this precaution can result in equipment damage.

5. Using the screws in the display hardware kit, secure the power meter to the display through the bottom two mounting feet holes. Tighten all screws to 6–9 lb-in (0.7–1.0 N•m).
6. Plug the other end of the communications cable into the display communications port (terminal 22, figure 4-1) on the power meter.

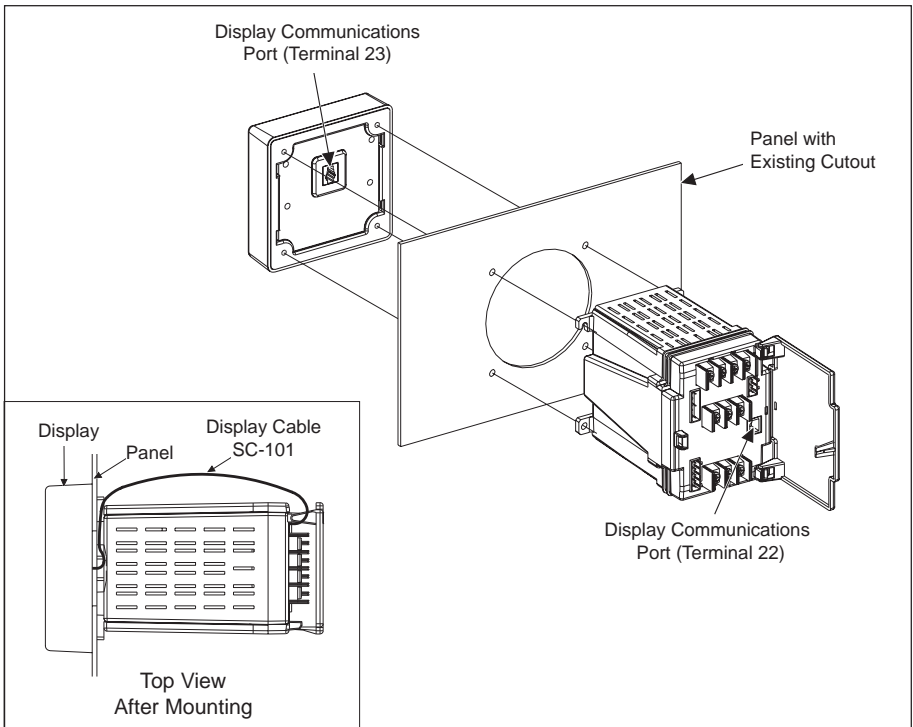

Figure 4-1: Mounting power meter and display on panel with existing ammeter/voltmeter cutout

Remote Mounting

To mount the power meter remotely (inside an enclosure), follow these steps:

DANGER

HAZARD OF ELECTRIC SHOCK, BURN, OR EXPLOSION.

Only qualified electrical workers should install and wire this equipment. Perform such work only after reading this complete set of instructions.

Failure to observe these precautions will result in death or severe personal injury!

CAUTION

HAZARD OF EQUIPMENT DAMAGE.

When mounting the power meter module, provide the following clearances (from enclosure walls or other objects): terminal end: 4" (102 mm); vented sides: 3" (76 mm). No clearance is necessary on the non-vented sides.

Failure to observe this precaution can result in equipment damage.

1. Turn off all power supplying the equipment before working on it. Follow all safety precautions.
2. Select a mounting location on the floor or wall of the enclosure, ensuring that there are adequate clearances, that the terminals are accessible, and that the location complies with local and state electrical codes.
3. Tape the template shipped with the module to the panel in the desired location (see figure 4-2, page 17); make sure the template is level. (Hole positions and dimensions are shown in figure 4-3, page 17.) Make sure no wires or equipment on the other side of the panel will be damaged, then drill through the panel at the 4 holes marked *A* on the template. Use a 3/16" drill bit.
4. Place the power meter mounting feet holes over the drilled holes and secure the power meter to the enclosure panel using No. 6 (maximum) screws or bolts suitable for the panel. Tighten to 6–9 lb-in (0.7–1.0 N•m).

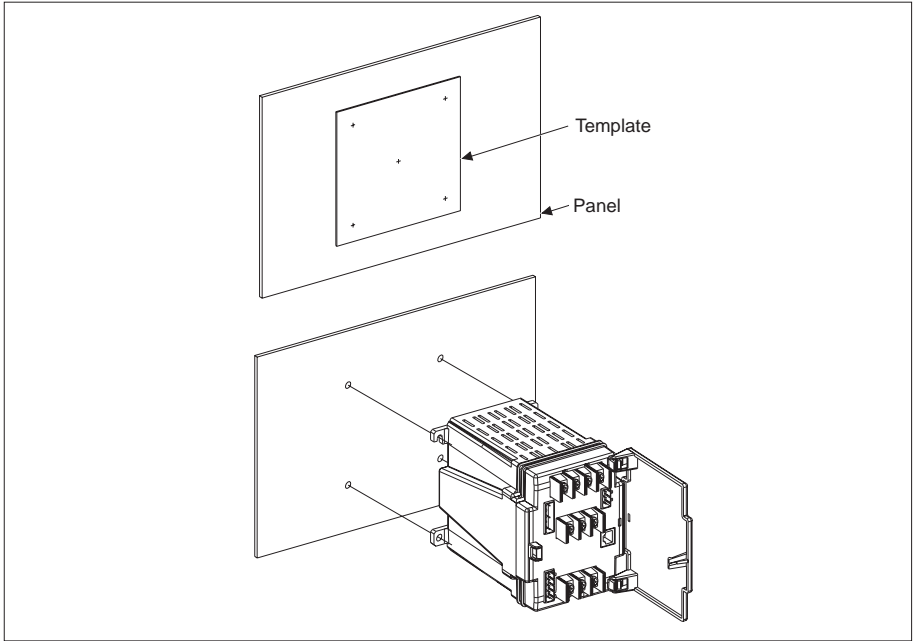
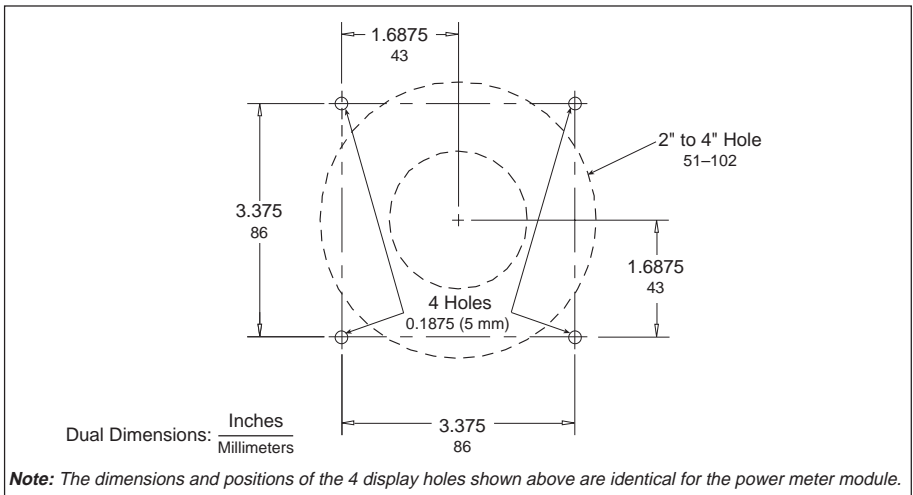

Figure 4-2: Mounting power meter on panel with no existing cutout



Note: The dimensions and positions of the 4 display holes shown above are identical for the power meter module.

Figure 4-3: Panel mount for the power meter display

DIN Rail Mounting

To mount the power meter onto 35 mm DIN rail, follow these steps:

DANGER

HAZARD OF ELECTRIC SHOCK, BURN, OR EXPLOSION.

Only qualified electrical workers should install and wire this equipment. Perform such work only after reading this complete set of instructions.

Failure to observe these precautions will result in death or severe personal injury!

1. Turn off all power supplying the equipment before working on it. Follow all safety precautions.
2. Mount a piece of 35 mm DIN rail in the desired location. *Note: The DIN rail must be horizontal.* Position the power meter in front of and slightly above the DIN rail (figure 4-4).

CAUTION

HAZARD OF EQUIPMENT DAMAGE.

When mounting the power meter module, provide the following clearances (from enclosure walls or other objects): terminal end: 4" (102 mm); vented sides: 3" (76 mm). No clearance is necessary on the non-vented sides.

Failure to observe this precaution can result in equipment damage.

3. Slip the two DIN rail hooks, located on the power meter case, onto the upper edge of the rail.
4. Rotate the power meter down and press it against the 35 mm DIN rail until the power meter snaps into place.

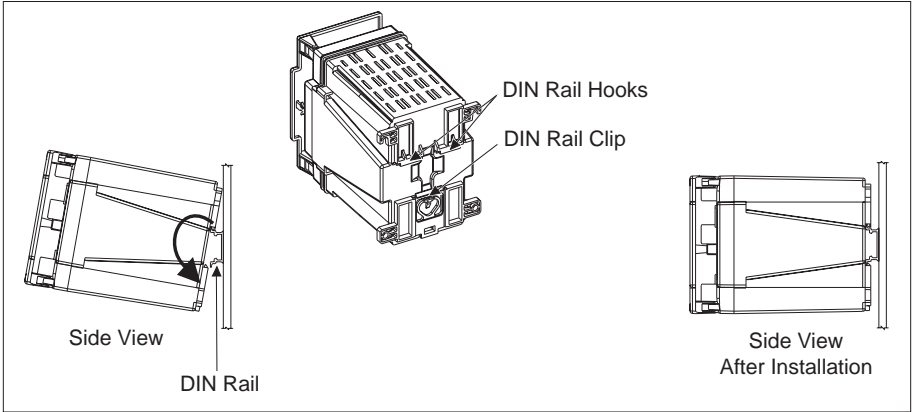

Figure 4-4: Mounting power meter on 35 mm DIN rail

CHAPTER 5—WIRING

DANGER

HAZARD OF PERSONAL INJURY OR DEATH.

Only qualified electrical workers should install and wire this equipment. Such work should be performed only after reading this complete set of instructions. Follow proper safety procedures regarding CT secondary wiring. Never open circuit the secondary of a CT.

Failure to observe this precaution will result in death or severe personal injury!

WIRING CTs, PTs, AND CONTROL POWER

CAUTION

HAZARD OF EQUIPMENT DAMAGE.

External fusing (customer-supplied) is *required* for control power inputs.

Failure to observe this precaution can result in equipment damage.

The power meter supports a variety of 3-phase power system wiring connections, including 3-wire delta, and 4-wire wye. Table 5-1 lists some of the most widely used system connections. Additional system connections are shown in **Appendix D**.

Table 5-1
System Connection Types

System Type	Sys ID	# CTs	# PTs ^①	PT Conn.	Currents	Voltages	Figure #
3Ø, 3W Delta Calculated B	30	2	0 or 2	Open Delta	A, B ^② , C	A-B, C-B, C-A ^②	5-3, 5-4
3Ø, 3W Delta Metered B Phase	31	3	0 or 2	Open Delta	A, B, C	A-B, C-B, C-A ^②	5-5
3Ø, 4W Wye	40	3	0 or 3	Wye-Wye	A, B, C, N ^③	A-N, B-N, C-N A-B ^④ , B-C ^④ , C-A ^④	5-6, 5-7

① PTs not required at 600 volts (line-to-line) or below.

② Calculated.

③ Calculated, PM-620 and PM-650.

④ Line-to-line voltage in the 4-wire mode is calculated and fundamental only.

Control Power Transformer (CPT) Sizing

If you are using control power transformers (CPTs), refer to table 5-2 below. It shows CPT sizing for various quantities of power meter modules.

Table 5-2
Control Power Transformer Sizing

Number of Power Meter Modules	Size of CPT
1–10	100 VA
11–20	150 VA
21–30	200 VA
31–40	250 VA

Control Power Fuses

The control power input(s) of each power meter module *must* be individually fused under all circumstances. When using a control power transformer where the secondary is 120 Vac, or when deriving control power from metering potential transformers, use a standard 250 V, 100 mA, fast-acting fuse. If control power is derived directly from the line voltage (600 V or less), each power meter module control input must be fused using a 1/2 amp Bussman FNQ-R fuse (or equivalent).

Metering Potential Transformers (PTs)

No potential transformers are required on the voltage metering inputs for wye-connected and ungrounded delta circuits with line-to-line voltages of 600 V or less; connect the voltage metering inputs directly to the line voltages. However, for power systems with voltages higher than 600 V line-to-line, or corner-grounded delta circuits, potential transformers *must* be used. To set up the appropriate voltage range, see page 50.

CE Compliance

To comply with CE Electromagnetic Compatibility Requirements, the power meter must be installed in a metallic enclosure, i.e., switchgear. Install the clamp-on ferrite provided in the hardware kit around all three control power input leads close to the power meter (figure 5-1). To open the clamp-on ferrite prior to installation, follow the instructions in figure 5-2.

For CE compliance, a Merlin Gerin Disconnect Breaker Type P25M #21104 or IEC 947 equivalent must be connected directly to the metering voltage and control power inputs (figure 5-1). *Note: The disconnect switch must be placed within reach of the power meter and labeled "Disconnect Switch for Power Meter."*

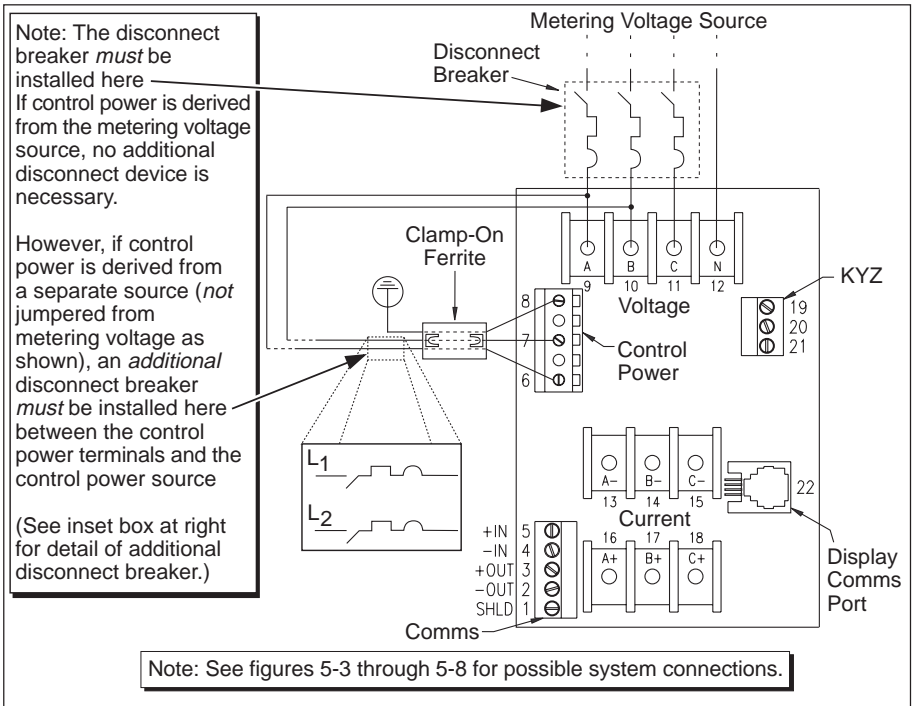

Figure 5-1: Clamp-on ferrite and disconnect breaker for CE compliance (4-wire system shown)

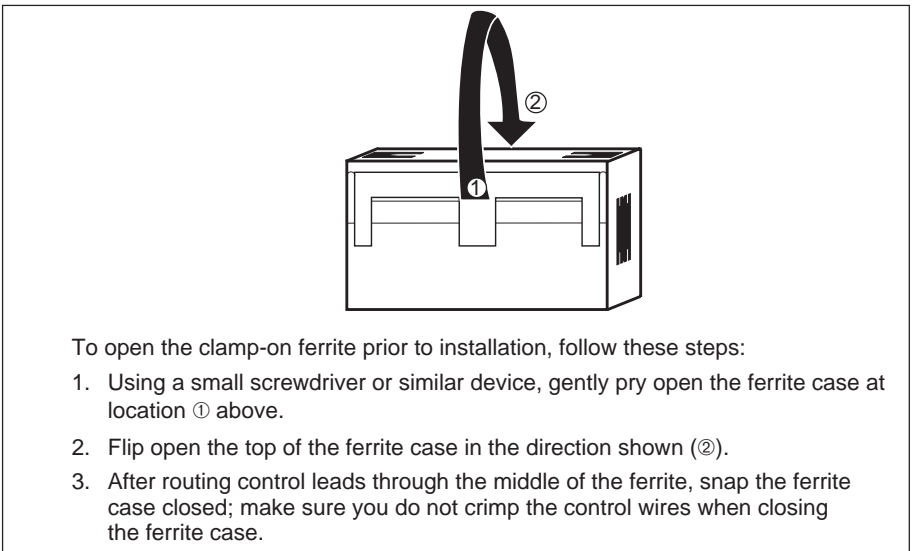
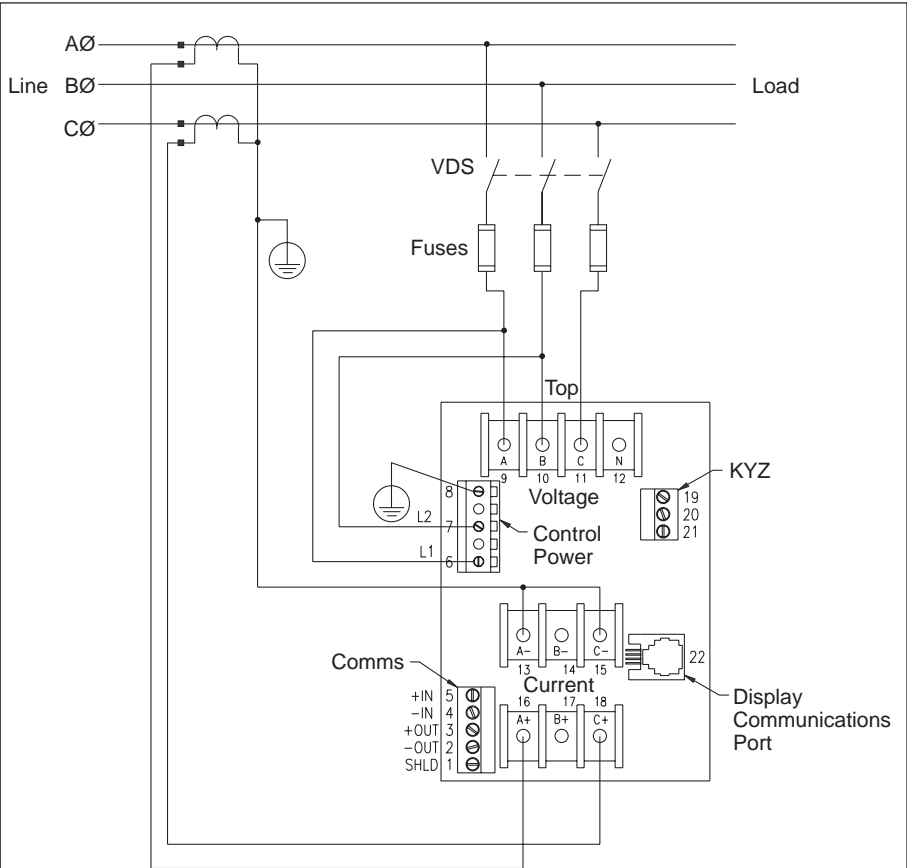

Figure 5-2: Opening the clamp-on ferrite



Note: Control power can be drawn from fused voltage inputs L-L or an external source. See page 22 for CPT and fuse recommendations.

Control power range: L1-L2 90–600 Vrms
90–300 Vdc

Installation Category II

For ungrounded delta systems only.

Figure 5-3: 3-phase, 3-wire delta direct voltage connection with 2 CTs

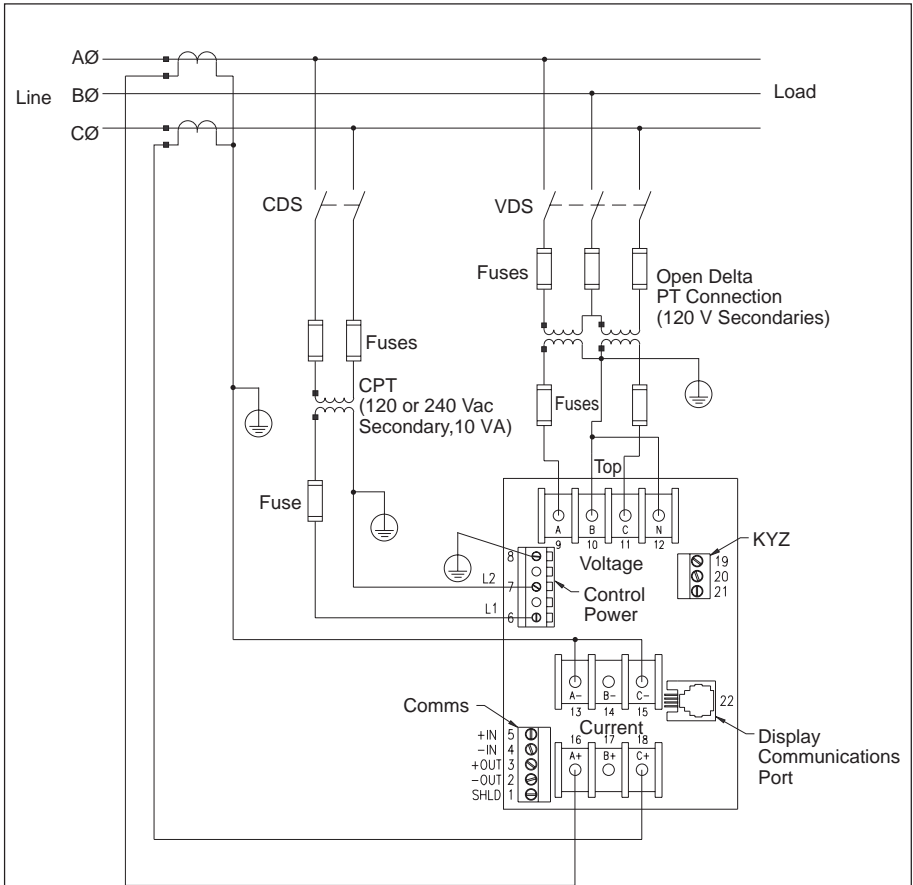

Note: Control power can be drawn from fused voltage inputs L-L or an external source. See page 22 for CPT and fuse recommendations.

Control power range: L1-L2 90–600 Vrms
 90–300 Vdc

Installation Category II

Figure 5-4: 3-phase, 3-wire delta with 2 PTs and 2 CTs

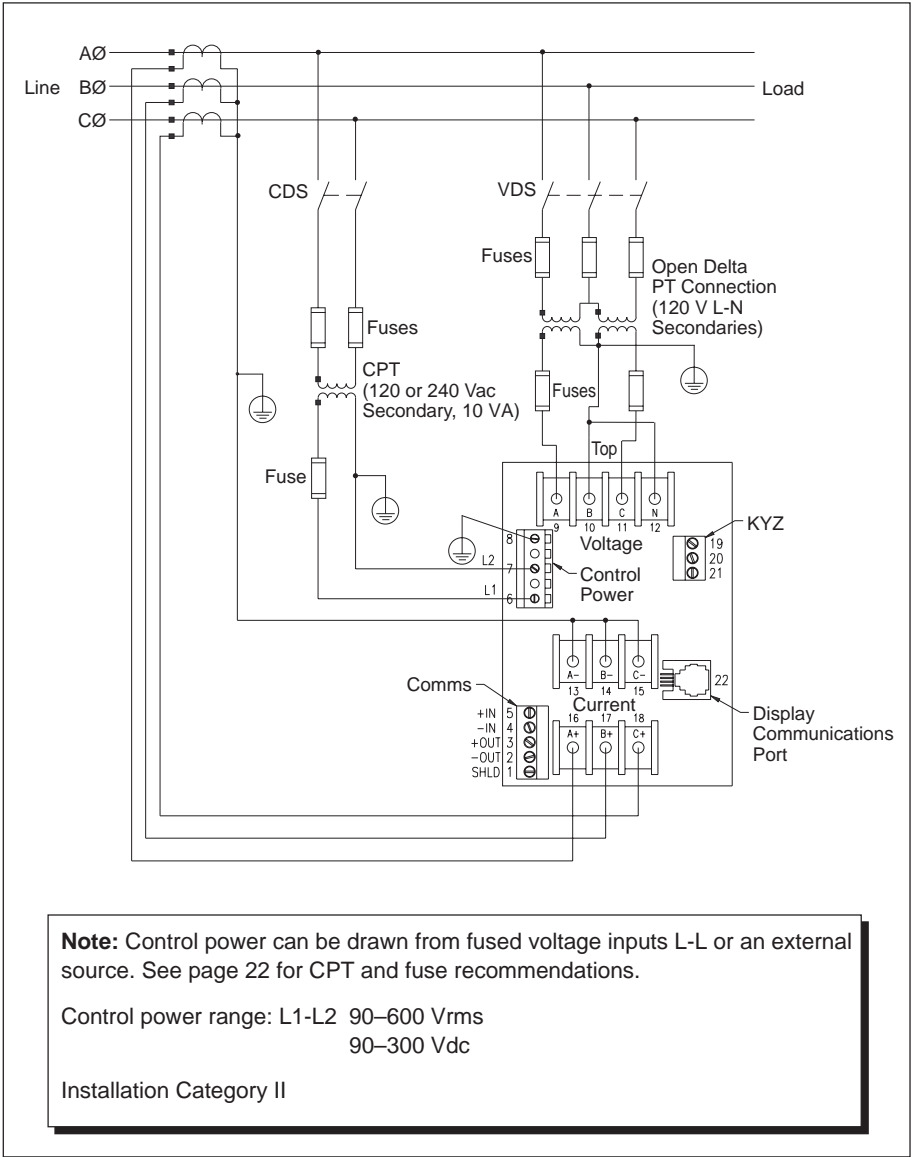

Figure 5-5: 3-phase, 3-wire delta with 2 PTs and 3 CTs

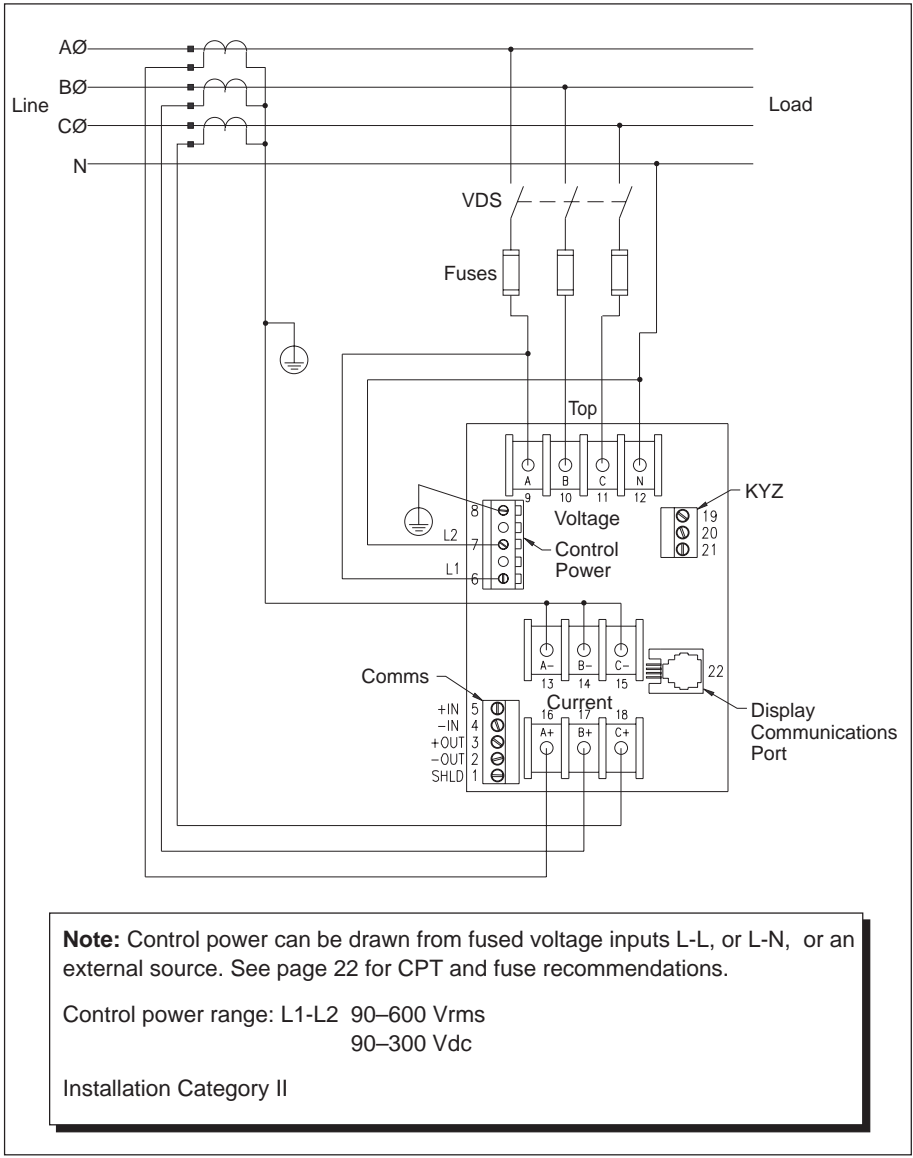
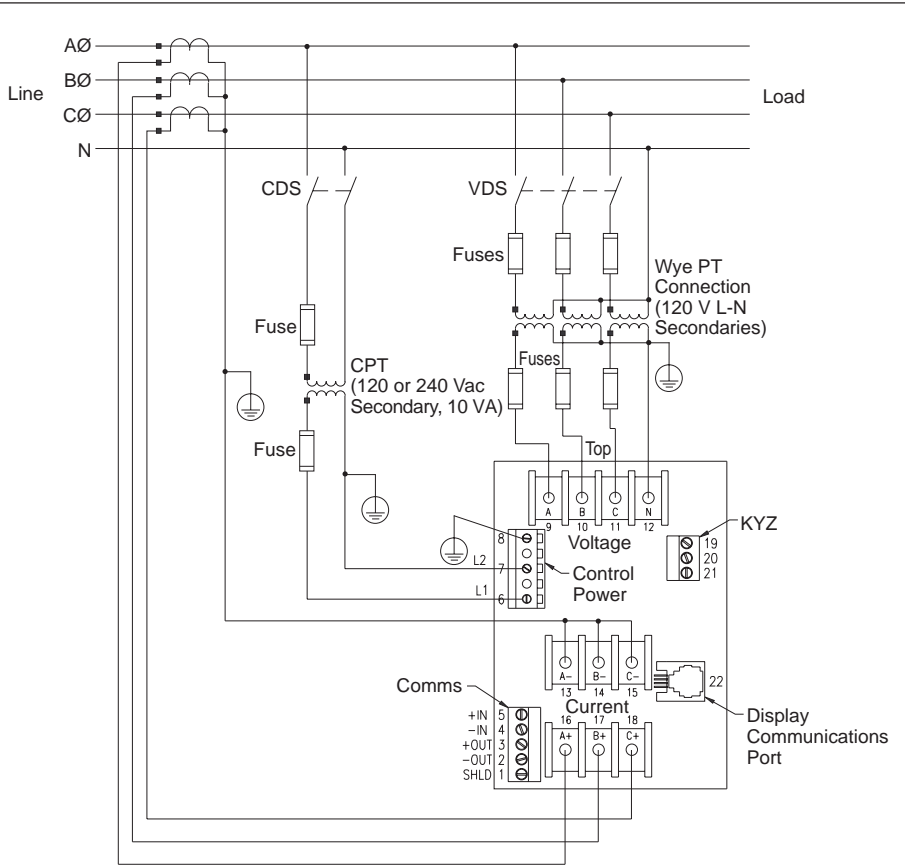

Figure 5-6: 3-phase, 4-wire wye, ground and direct voltage connection, with 3 CTs



Note: Control power can be drawn from fused voltage inputs L-L, or L-N, or an external source. See page 22 for CPT and fuse recommendations.

Control power range: L1-L2 90–600 Vrms
90–300 Vdc

Installation Category II

Figure 5-7: 3-phase, 4-wire wye, ground connection, with 3 PTs and 3 CTs

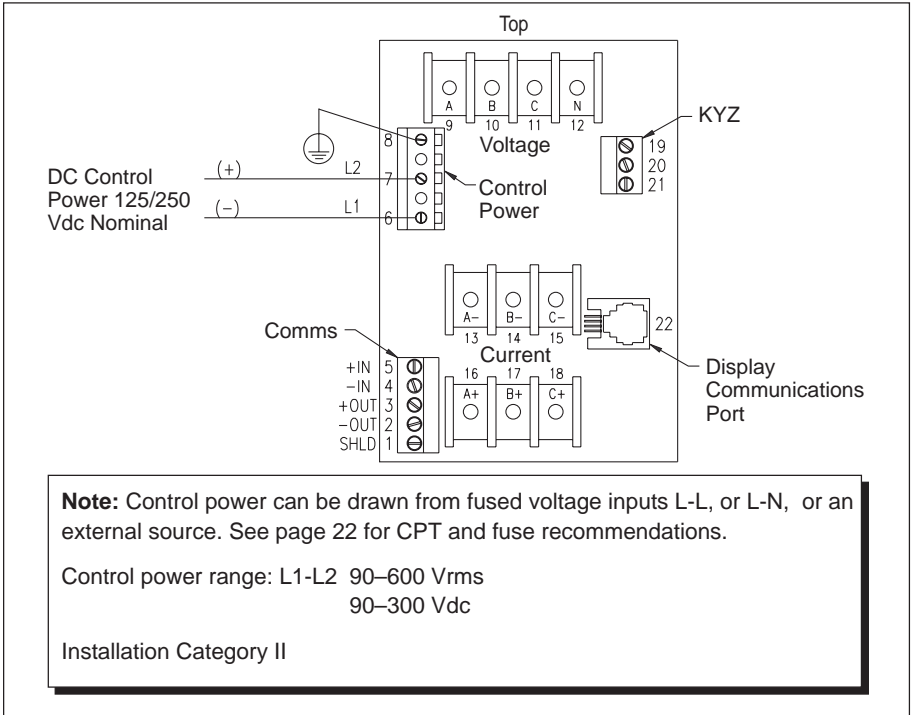

Figure 5-8: DC control power wiring

Typical power meter module wire routing is shown in figure 5-9 below.

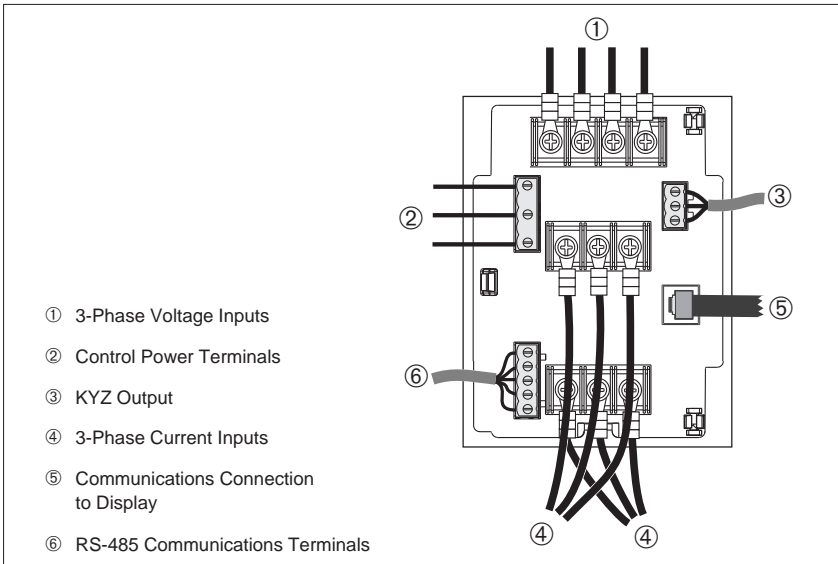

Figure 5-9: Power meter wire routing

DANGER

HAZARD OF ELECTRICAL SHOCK, BURN, OR EXPLOSION.

- Before removing the terminal shield or making connections, turn off all power supplying this equipment.
- Refer to the terminal identifications label on the terminal shield for proper wiring polarities.
- Refer to page 22 for CPT and fuse recommendations.
- Snap terminal shield into closed position before turning power on.

Failure to observe these precautions will result in death or severe personal injury!

To wire the power meter, follow these steps:

1. Strip 0.25" (6 mm) of insulation from the end of all wires. Using a suitable crimping tool, attach the spade connectors (in hardware kit) to the voltage and current input wires (up to 12 AWG) as shown in figure 5-9.

2. Connect the spade connectors to the 3-phase voltage input terminals (①, figure 5-9) and the 3-phase current input terminals (④, figure 5-9). Tighten the terminal block screws to 9 lb-in (1.0 N•m).
3. Insert 14 AWG control power wires into the control power terminal block as shown in figure 5-9. Derive control power from one of these sources:
 - a stable ac source
 - phase voltage inputs
 - dc power source

Tighten terminal screws to 4 lb-in (0.45 N•m).

4. Ground the power meter. See **Grounding the Power Meter** in this chapter for instructions.
5. If all wiring is complete, snap the terminal shield into the closed position.



CAUTION

HAZARD OF EQUIPMENT DAMAGE.

External fusing is required when bringing line voltages to the power meter or other metering device.

Failure to observe this precaution can result in equipment damage.

Deriving Control Power from Phase Voltage Inputs

Whenever possible, derive power meter control power from a stable voltage source. If such a source is unavailable, the power meter can derive control power from the metered circuit up to 600 V, or from its phase PT inputs. Due to the wide range of permissible control power inputs, the power meter can accept either L-N or L-L control power inputs up to 600 V.



DANGER

HAZARD OF ELECTRICAL SHOCK, BURN, OR EXPLOSION.

- Turn off all power supplying this equipment before opening the terminal shield or making connections.
- Snap terminal shield into closed position before turning power on.

Failure to observe these precautions will result in death or severe personal injury!

Note: Before wiring, see fuse recommendations on page 22.

Follow these steps to derive control power from phase PT inputs:

1. Connect the Va terminal (terminal 9) to the L1 terminal (terminal 6).
2. For L-N control power (see figure 5-6, page 27), connect the Vn terminal (terminal 12) to the L2 terminal (terminal 7). For L-L control power (see figure 5-3, page 24), connect the Vb terminal (terminal 10) to the L2 terminal (terminal 7).
3. If all wiring is complete, snap the terminal shield into the closed position.

GROUNDING THE POWER METER

For optimal grounding, connect the power meter to a true earth ground.

To ground the power meter, follow these steps:

1. Connect the ground terminal (terminal 8) to a true earth ground, using #14 AWG wire.
2. After grounding, snap the terminal shield into the closed position.

*Note: The power meter **must** be grounded as described in these instructions. Failure to properly ground the power meter may induce noise on the power conductor.*

SOLID-STATE KYZ PULSE OUTPUT

DANGER

HAZARD OF ELECTRICAL SHOCK, BURN, OR EXPLOSION.

- Turn off all power supplying this equipment before opening the terminal shield or making connections.
- Snap terminal shield into closed position before turning power on.

Failure to observe these precautions will result in death or severe personal injury!

The KYZ output can be wired to a 2-wire or 3-wire pulse receiver. To wire to a 2-wire pulse receiver, use the K and Y terminals only (figure 5-10). When wiring the KYZ pulse output, use 14 to 18 AWG wire. Strip 0.25" (6 mm) of insulation from the end of each wire being connected to the KYZ connector. Insert the wires into the KYZ output terminal block. Tighten the terminal block screws to 5–7 lb-in (0.56–0.79 N•m).

Note: Set up the KYZ by using either the Setup mode on the power meter display or the setup screen in SMS-3000, SMS-1500, or PMX-1500 software. See page 65 for instructions for determining the pulse constant.

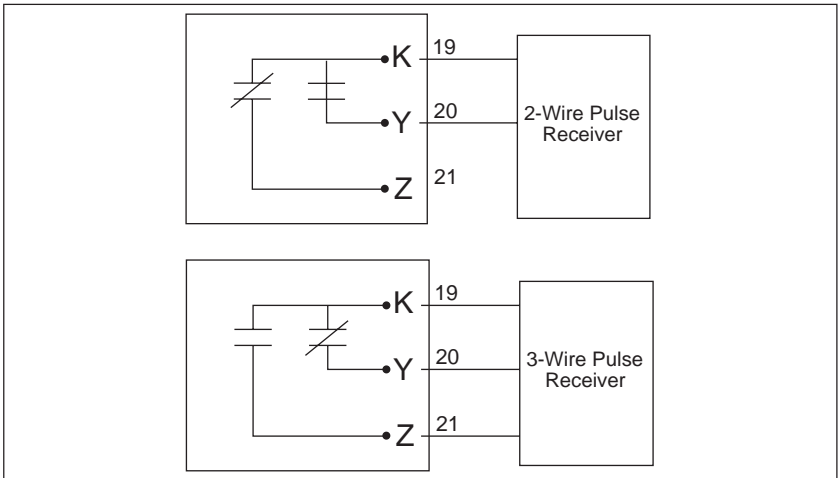

Figure 5-10: KYZ pulse output

For the PM-650 only, the KYZ output can also be wired as an alarm contact (figure 5-11). When wiring the KYZ output, use 14 to 18 AWG wire. Strip 0.25" (6 mm) of insulation from the end of each wire being connected to the KYZ connector. Insert the wires into the KYZ output terminal block. Tighten the terminal block screws to 5–7 lb-in (0.56–0.79 N•m).

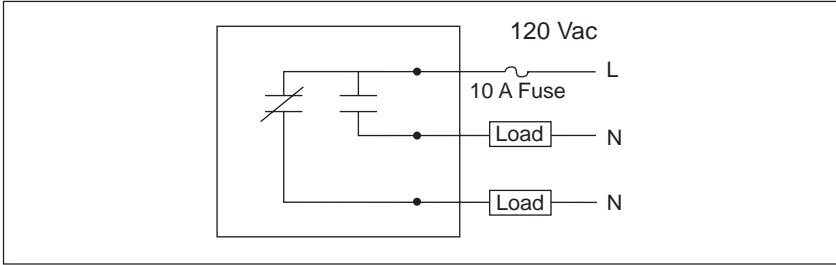

Figure 5-11: Typical KYZ output connection for use as an alarm contact

CHAPTER 6—COMMUNICATIONS

PROTOCOLS

POWERLOGIC Power Meters can communicate using three different protocols:

- POWERLOGIC
- Modbus
- Jbus

During setup, select which protocol will be used.

Descriptions of the connections that can be used with each protocol follow.

Note: For 2-wire Modbus and Jbus information, see **Appendix H—2-Wire Modbus and Jbus**.

POWERLOGIC PROTOCOL COMMUNICATIONS WIRING

POWERLOGIC devices are equipped with RS-485 communications. You can daisychain up to 32 POWERLOGIC (or Power Monitoring and Control System [PM&CS]) compatible devices to a single communications port. This document refers to a chain of PM&CS devices connected by communications cable as a *communications link*.

A PM&CS communications link can consist of up to 32 PM&CS-compatible devices connected to a communications port on one of the following:

- Personal computer
- POWERLOGIC Network Interface Module (PNIM)
- SY/MAX[®] programmable controller
- POWERLOGIC Ethernet Gateway
- Other host devices with a POWERLOGIC-compatible port

Figures 6-1 through 6-3 show power meters (other PM&CS-compatible devices can be substituted) connected in typical systems. The accompanying text describes important considerations for each connection alternative.

The figures also show the placement of communications adapters and terminators. For additional information on using the communications adapter and terminator, see **Terminating the Communications Link**, and **Biasing the Communications Link** in this chapter.

Connecting to a Personal Computer via POWERLOGIC Communications

- Connect up to 32 PM&CS devices to a personal computer (figure 6-1). See **Length of the Communications Link** in this chapter for distance limitations at varying baud rates.
- PM&CS devices can be connected to a SY/LINK card installed in the personal computer. To do this, connect the PM&CS devices to the RS-422 port (female DB-9 connector) of the SY/LINK card.
- PM&CS devices can be connected to a serial communications port on the personal computer. To do this, the PM&CS devices must be connected to an RS-232-to-RS-422/RS-485 converter, which is connected to the personal computer. POWERLOGIC offers a converter kit for this purpose (Class 3090 Type MCI-101; refer to the instruction bulletin included with the MCI-101 for connection instructions).

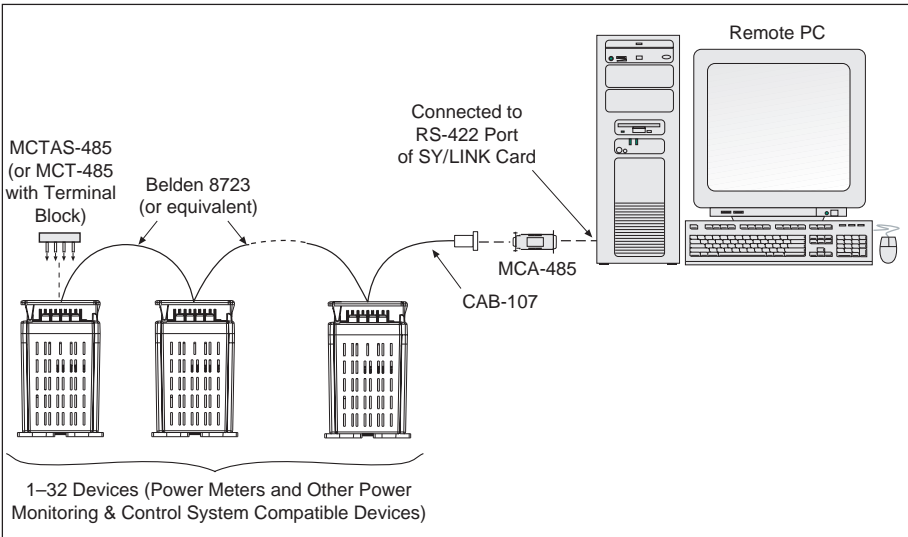

Figure 6-1: Power meters connected to a personal computer via SY/LINK card

Connecting to a POWERLOGIC Network Interface Module (PNIM) Using POWERLOGIC Communications

- Connect up to 32 PM&CS devices to a PNIM. See **Length of the Communications Link** in this chapter for distance limitations at different baud rates.
- Connect PM&CS devices to PNIM port 0 (top RS-485 port) only.
- Configure PNIM port 0 for “POWERLOGIC” mode (see side of PNIM for instructions on setting dip switches).
- Configure the baud rate of PNIM port 0 to match the baud rate of the PM&CS devices on the communications link.
- Refer to the PNIM instruction bulletin for detailed instructions on configuring the PNIM.

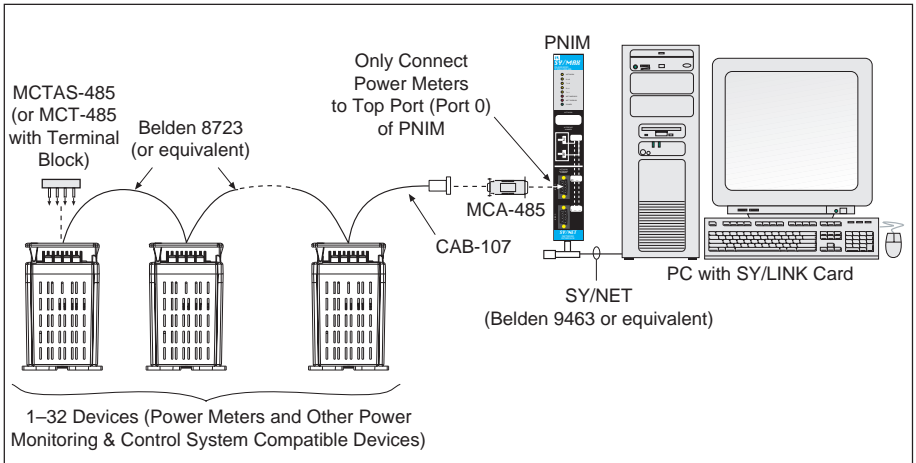

Figure 6-2: Power meters connected to a PNIM

Connecting to a SY/MAX Programmable Controller Using POWERLOGIC Communications

- Connect up to 32 PM&CS devices to a programmable controller. See **Length of the Communications Link** in this chapter for distance limitations at different baud rates.
- Connect PM&CS devices to the RS-422 port of the programmable controller.
- The programmable controller must contain a program to access POWERLOGIC device data.
- Configure the baud rate of the programmable controller's port to match the baud rate of the POWERLOGIC devices on the communications link.
- Refer to the programmable controller instruction manual for detailed instructions on configuring the programmable controller.

Note: PM&CS devices can be connected to other manufacturers' systems using available communication interfaces. For further information, contact the POWERLOGIC Technical Support Center.

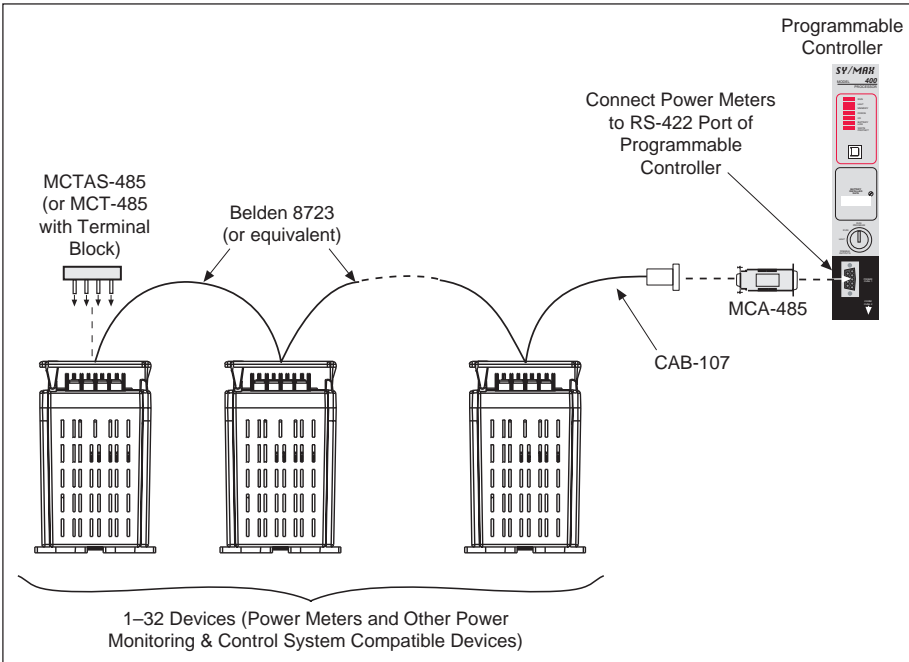

Figure 6-3: Power meters connected to a SY/MAX programmable controller

MODBUS RTU PROTOCOL

Alternately, power meters can communicate using the Modbus RTU protocol. Using 4-wire Modbus, you can daisychain up to 32 power meters to a single communications port. When using 2-wire Modbus communications, a maximum of 16 power meters can be daisychained to a single communication port.

Note: See Appendix H for 2-wire Modbus wiring and distance limits.

A power meter Modbus communications link can be connected to a communications port on any of the following:

- personal computer
- Modicon programmable controller
- other host devices with a Modbus-compatible port

JBUS PROTOCOL

Jbus is the third protocol by which power meters can communicate. When using 4-wire Jbus, up to 32 power meters can be daisychained from a single communications port. For 2-wire Jbus, a maximum of 16 power meters can be daisychained.

Note: See Appendix H for 2-wire Jbus wiring and distance limits.

You can connect a power meter Jbus communications link to any host device with a Jbus-compatible port.

CONNECTING TO A PC USING MODBUS OR JBUS COMMUNICATIONS

- Connect up to 32 Modbus or Jbus devices to a personal computer (figure 6-4). See **Length of the Communications Link** in this chapter for distance limitations at varying baud rates.
- Power meters configured for Modbus or Jbus can be connected to a serial communications port on the personal computer. To do this, the power meters must be connected to an RS-232-to-RS-422/RS-485 converter, which is connected to the personal computer. POWERLOGIC offers a converter kit for this purpose (Class 3090 Type MCI-101; refer to the instruction bulletin included with the MCI-101 for connection instructions).

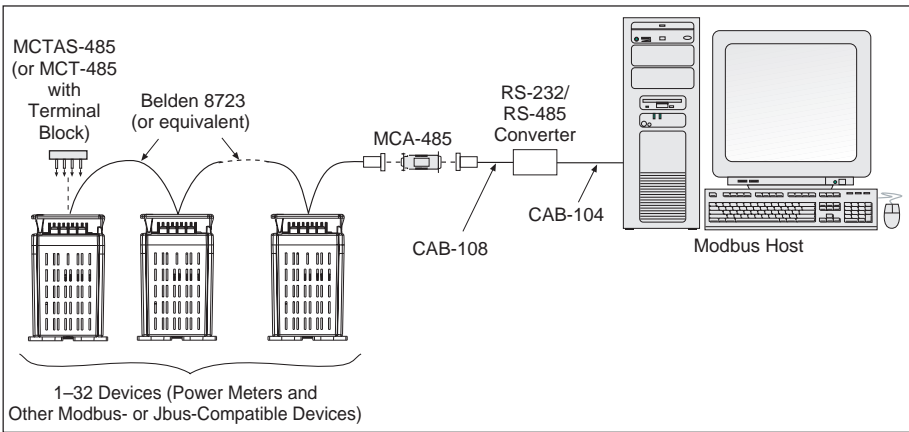

Figure 6-4: Power meters connected to a personal computer via serial port

LENGTH OF THE COMMUNICATIONS LINK (POWERLOGIC, MODBUS, OR JBUS)

The length of the communications link cannot exceed 10,000 feet (3,048 m). This means that the total length of the communications cable from the PNIM, personal computer, or PLC, to the last device in the daisychain, cannot exceed 10,000 feet. The maximum distance may be shorter, depending on the baud rate. Table 6-1 shows the maximum distances at different baud rates.

Table 6-1
Maximum Distances of Comms Link at Different Baud Rates

Baud Rate	Maximum Distances	
	1–16 devices	17–32 devices
1200	10,000 ft. (3,048 m)	10,000 ft. (3,048 m)
2400	10,000 ft. (3,048 m)	5,000 ft. (1,524 m)
4800	10,000 ft. (3,048 m)	5,000 ft. (1,524 m)
9600	10,000 ft. (3,048 m)	4,000 ft. (1,219 m)
19200	5,080 ft. (1,548 m)	2,500 ft. (762 m)

Note: See Appendix H for 2-wire Modbus and Jbus wiring distance limits.

DAISYCHAINING PM&CS DEVICES (POWERLOGIC, MODBUS, OR JBUS)

Note: To daisychain the power meter with other PM&CS, Modbus, or Jbus devices, use a communications cable containing two twisted-shielded pairs (Belden 8723 or equivalent). Strip back the cable sheath 2" (51 mm) on each end of the cable, and strip back the insulation 0.25" (6 mm) from the end of each wire. Then follow daisy chaining instructions in this section. Torque terminal block screws to 5–7 lb-in (0.56–0.79 N•m).

Each communicating power meter has a 5-position plug-in RS-485 terminal block for connection to a PM&CS, Modbus, or Jbus communications link. On all PM&CS devices, the terminals are labeled IN+, IN-, OUT+, OUT-, and SHLD. On the power meter, the IN+, IN-, OUT+, OUT-, and SHLD terminals are numbered 5, 4, 3, 2, and 1, respectively.

To daisychain a power meter to another PM&CS, Modbus, or Jbus device, wire the power meter's RS-485 communications terminals to the matching communications terminals of the next device (wire the IN+ terminal of the power meter to the IN+ terminal of the next device, wire IN- to IN-, OUT+ to OUT+, OUT- to OUT-, and SHLD to SHLD). See figure 6-5.

If the power meter is the last device on the daisychain, use a terminator at the end of the link. See **Terminating the Communications Link** in this chapter for instructions. If the power meter is the first device on the daisychain, connect it to the PNIM, personal computer, or programmable controller using a CAB-107 or equivalent cable and a Multipoint Communications Adapter. See **Biasing the Communications Link** in this chapter for instructions. See **Appendix C** for the CAB-107 pinout.

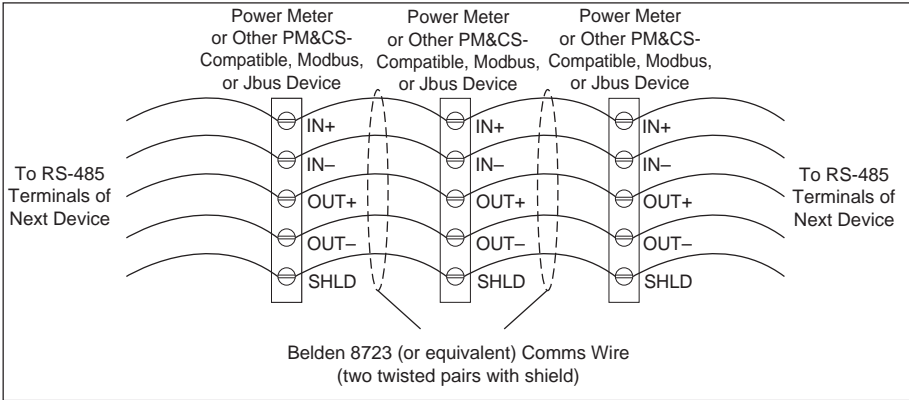

Figure 6-5: Daisychaining the RS-485 communications terminals

BIASING THE COMMUNICATIONS LINK (POWERLOGIC, MODBUS, OR JBUS)

For proper RS-485 communications performance, the communications link must be biased (figure 6-6) using a POWERLOGIC Multipoint Communications Adapter (Class 3090 Type MCA-485). The adapter is placed between the first device on the link and the communications port of a PNIM, SY/LINK card, or other host device.

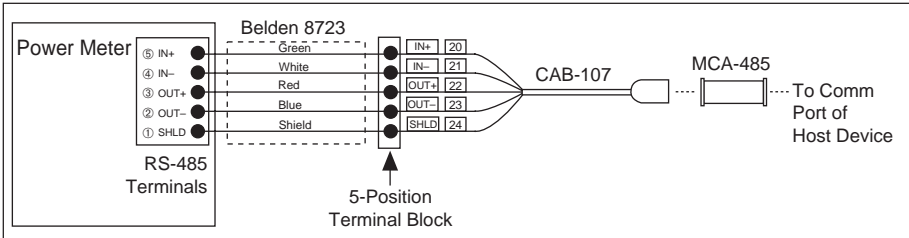

Figure 6-6: Connecting the power meter as the first device on a PM&CS or Modbus communications link

To bias the communications link, refer to figure 6-6 and follow these steps:

1. Install the 5-position terminal block in a convenient location.

Note: The CAB-107 cable is 10 feet (3 m) long. If the terminal block must be located farther than 10 feet from the host device, build a custom cable using Belden 8723 cable and a male DB-9 connector. See the CAB-107 pinout, page 74.

2. Plug the male end of the Multipoint Communications Adapter (MCA-485) into the communications port of the PNIM, SY/LINK board, or other host device.

Note: When connecting to a PNIM, connect the power meter to the top RS-422 port, labeled port 0. This port **must** be configured for POWERLOGIC mode.

- Carefully mark the flying leads on the CAB-107 as indicated in table 6-2 below. For example, mark the green wire, labeled 20, as "IN+"; mark the white wire, labeled 21, as "IN-"; and so on.

Table 6-2
Labeling the CAB-107 Leads

Existing Label	Wire Color	Mark As
20	Green	IN+
21	White	IN-
22	Red	OUT+
23	Black	OUT-
24	Silver	SHLD

- Attach the male DB-9 connector on the CAB-107 to the multipoint communications adapter.
- Connect the CAB-107 spade connectors to the 5-position terminal block. See figure 6-8, page 45, for terminal identification.
- Cut a length of Belden 8723 (or equivalent) cable that is long enough to reach from the terminal block to the first power meter. Strip back the cable sheath 1-1/4" (32 mm) from both ends.
- On one end of the Belden 8723 (or equivalent) cable, carefully strip .25" (6 mm) of insulation from the end of each wire to be connected. Using a suitable crimping tool, securely attach a forked terminal (spade connector) to each wire.
- Connect the cable end with attached spade connectors to the terminal block. See figure 6-8, page 45, for terminal identification. Tighten all terminal screws to 6-9 lb-in (0.68-1 N•m).
- On the other cable end, carefully strip .4"-.45" (10-11 mm) of insulation from the end of each wire to be connected.
- Connect this end of the Belden 8723 (or equivalent) cable to the power meter RS-485 terminals; see figure 6-8, page 45, for communications terminal identification. Be sure to connect the terminal accepting the IN- wire on the CAB-107 to the IN- terminal on the power meter, the terminal accepting the IN+ wire on the CAB-107 to the IN+ terminal on the power meter, and so on. Tighten the RS-485 terminal screws to 5-7 lb-in (0.56-0.79 N•m).

Note: An alternative to using a terminal block and a CAB-107 is to build a custom cable using Belden 8723 cable (or equivalent) and a male DB-9 connector. When building a cable, follow the CAB-107 pinout shown in Appendix C.

Terminating the Communications Link (POWERLOGIC, Modbus, or Jbus)

For proper RS-485 communications performance, terminate the last device on a PM&CS or Modbus communications link. To terminate the last device, use a POWERLOGIC Multipoint Communications Terminator.

Terminate the power meter using one of the following methods:

- MCTAS-485. This terminator plugs directly into the power meter communications port (RS-485 terminals in figure 6-7 below).
- Terminal block and MCT-485. In this method, communications wires route from the last power meter on a daisychain to a 5-position terminal block. A terminator attaches to the terminal block. See figure 6-8.

Figures 6-1 to 6-4 show the terminator applied in typical systems.

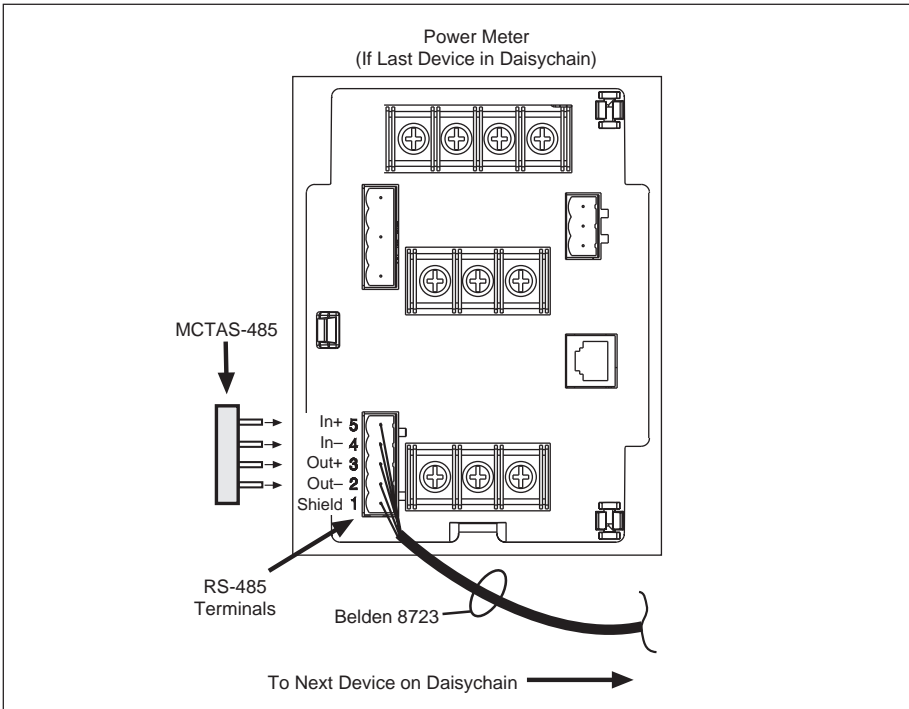

Figure 6-7: Terminating power meter with MCTAS-485

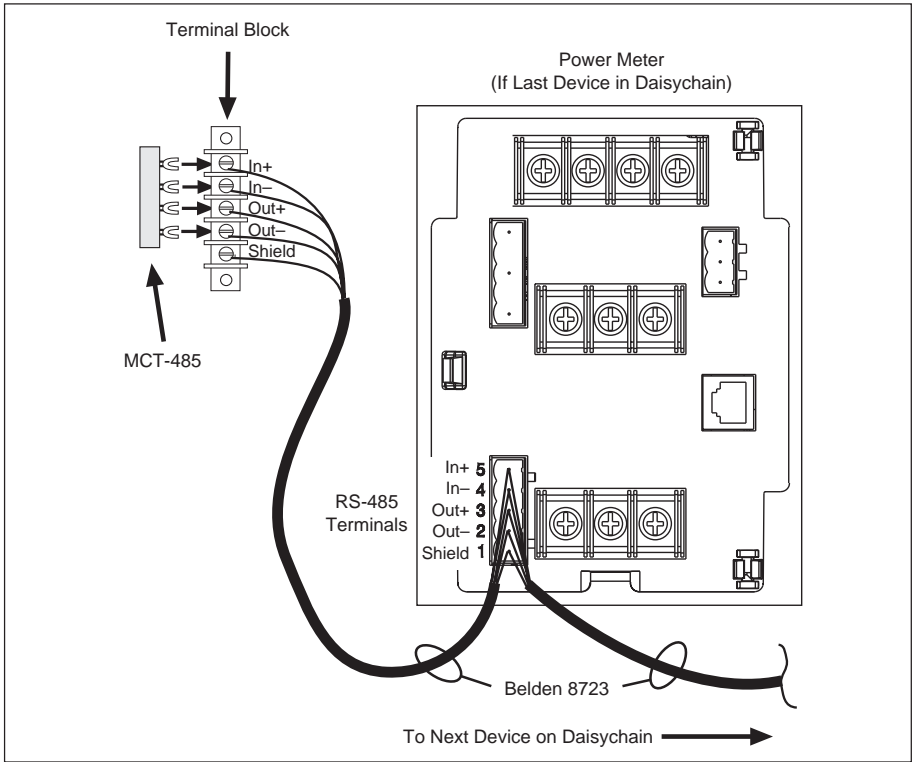

Figure 6-8: Terminating power meter with terminal block and MCT-485

CHAPTER 7—DISPLAY OPERATION

INTRODUCTION

This chapter tells how to set up the power meter from the display only. You can also set up the power meter using POWERLOGIC *SMS-3000*, *SMS-1500*, or *PMX-1500* software. Refer to the software instruction bulletin(s) for specific instructions.

MODES

The power meter has the following modes. Each mode is detailed in this section.

- Summary
- Power
- Energy
- Demand ^①
- Power Quality ^①
- Min/Max ^②
- Alarm Setup ^②
- Alarm Log ^②
- Setup
- Resets
- Diagnostics

^① PM-620 and PM-650.

^② PM-650 only.

Accessing a Mode

To access a mode, refer to figure 7-1 while following these steps:

1. Press the *Mode* button until the desired mode appears (①, figure 7-1).
2. Press *Select* to enter the desired mode.
3. For Setup, Resets, Diagnostics, Alarm Log**, or Alarm Setup** modes, press the *Select* button to select a field (②), and move through screens in that mode.

For Summary, Power, Energy, Demand*, Power Quality* (PQ), and Min/Max** modes, press *Select* to enter a display mode, then use the arrow buttons to move through the display screens (③).

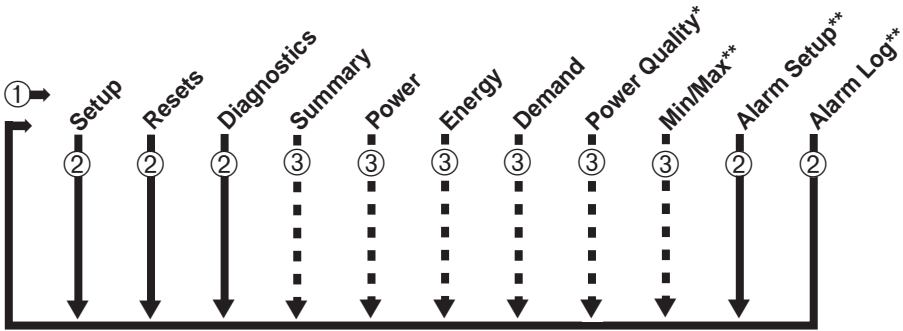

Figure 7-1: Navigating power meter parameters

* PM-620 and PM-650.

** PM-650 only.

Setup Mode

The Setup mode lets you configure the following parameters:

- Protocol
- Device Address
- Baud Rate
- Parity (even or none)
- CT Primary
- CT Secondary
- Voltage Range
- PT Primary
- PT Secondary
- System Type
- Frequency
- Power Demand Interval^①
- KYZ Mode
- Pulse Constant^②
- THD/thd^①

You can also set the date^①, time^①, master password, and reset password.

^① PM-620 and PM-650.

^② The pulse constant parameter is displayed only when the KYZ mode is enabled (KWH, KVAH, or KVARH energy mode).

Note: Because the power meter can directly meter up to 600 V line-to-line without using potential transformers, you must specify the appropriate voltage range during the setup procedure. To determine what voltage range to enter during setup, find your system voltage in table 7-1 below. Enter the corresponding voltage range.

If your specific system voltage is not listed, use the next highest voltage range. If your system voltage is greater than 600 V_{L-L} or 347 V_{L-N}, then you must use PTs and select 208/120 V as the voltage range.

Table 7-1
Selecting Voltage Ranges for System Types

System Voltage	Set Power Meter Voltage Range To:
4-wire:	
208/120 V	208/120 V
480/ 277 V	480/277 V
600/347 V	600/347 V
>600/347 V	208/120 V with PTs ①
3-wire (Delta)②:	
240 V	480/277 V
480 V	480/277 V
600 V	600/347 V
>600 V	208/120 V with PTs ①

① Note: Set PT ratios.

② For 3Ø, 3-wire delta corner-grounded applications, install two line-to-line rated PTs. Set the voltage range to 208/120 V with PTs.

Resets Mode

The Resets mode allows you to reset energy, demand^③, and min/max values^④. See **Performing Resets**, page 54, for more information.

Diagnostics Mode

The Diagnostics mode displays the model number and serial number of your power meter, as well as firmware versions and a read-only register interface. For more information, see **Viewing Diagnostic Information**, page 55.

Display Modes

The display modes—Summary, Power, Energy, Demand^③, Power Quality^③, and Min/Max^④—each display information indicated by their titles.

③ PM-620 and PM-650.

④ PM-650 only.

How the Buttons Work

The buttons on the power meter display (figure 7-2) function differently in Setup, Resets, Diagnostics, Alarm Log^①, and Alarm Setup^① than they do in the display modes.



Figure 7-2: Power meter display buttons

Mode Button

This button lets you scroll through available modes. You can also use this button to exit a mode after making all desired changes. For example, after making all desired changes in Setup mode, press the *Mode* button. The power meter then prompts you to accept or reject your changes.

Arrow Buttons

Use these buttons to increase or decrease the displayed parameter. Also, use these buttons to toggle between *Yes* and *No* when required.

Select Button

This button allows you to enter a selected mode and scroll through fields within that mode. Also use this button as an “Enter” key to accept a new configuration value and move to the next field.

Contrast Button

This button allows you to adjust the contrast of the display screen.

^① PM-650 only.

SETTING UP THE POWER METER

To set up the power meter, follow these steps:

1. Press the *Mode* button until “Mode: Setup” is displayed on the screen.
2. Press the *Select* button. At the “Enter Password” prompt, press the up arrow button once to enter the default password 0 (if you have set up a different password, use that instead).
3. Press *Select* until the desired setup parameter is displayed. Change the value using the up and down arrow buttons.
4. Repeat step 3 until all desired changes are made. Table 7-2 below shows setup parameters, the factory default for each, and the allowable range of values.
5. After making all desired changes, press the *Mode* button. The display reads “Save Changes? NO.”
6. To reject changes, press the *Select* button once.
7. To accept changes, press an arrow button to change from “NO” to “YES.” Then press the *Select* button.
8. The power meter accepts the setup changes and restarts.

Table 7-2
Factory Defaults for Power Meter Setup Parameters

Parameter	Allowed Values	Default
Protocol	POWERLOGIC, Modbus, or JBus	POWERLOGIC
Network Address	0 to 199	1
Baud Rate	1200–19200	9600
Parity	even, none	even
CT Primary (3-Phase)	1 to 32,767	5
CT Secondary	1, 5	5
Voltage Range ①	208/120 V, 480/277 V, 600/347 V	208/120 V
PT Primary 3-Phase	1 to 1,700,000	120
PT Secondary	100, 110, 115, 120	120
System Type	40, 4-wire; 31, 3-wire (3 CT); 30, 3-wire (2 CT)	40, 4-wire
Frequency (Nominal)	50, 60 Hz	60 Hz
Demand Interval (Power) ②	1 to 60 min.	15
KYZ Mode	kWH, KYZ Disabled ③, kVAH, kVARH Alarm Mode ④	kWH
Pulse Constant (WH/Pulse Output [KVARH, KVAH])	0 to 327.67 kWH	0
THD ②	THD (United States) thd (European)	THD (United States)
Password (Master and Reset)	0 to 9998	0

① See note on voltage range selection, page 50.

② PM-620 and PM-650.

③ PM-600 and PM-620.

④ PM-650 only.

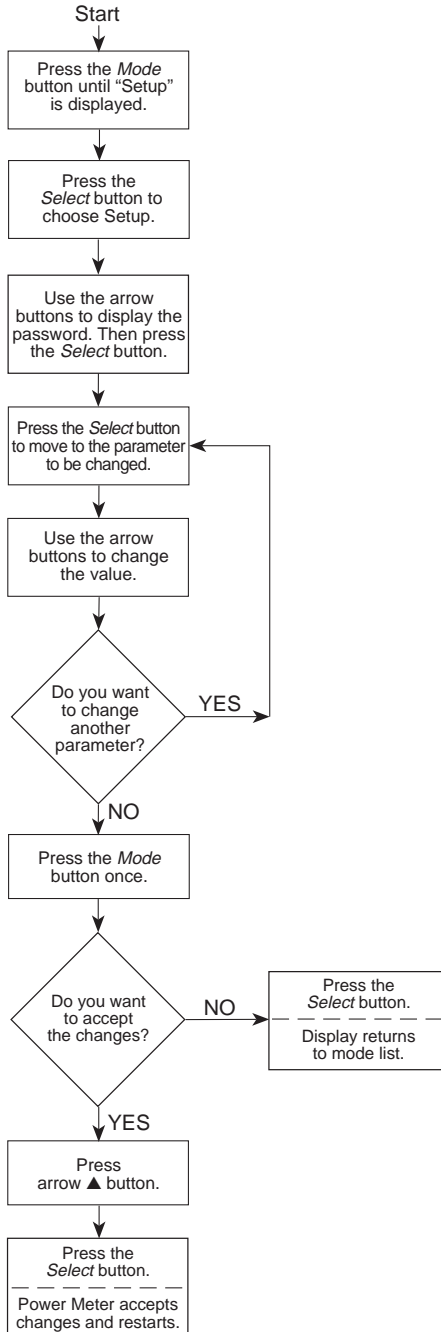

Figure 7-3: Power meter setup flowchart

PERFORMING RESETS

To reset energy, demand^①, and min/max^② values using the display, follow these steps:

1. Press the *Mode* button until “Resets” is displayed.
2. Press the *Select* button to enter the Resets mode. The display shows the password prompt.
3. Use the arrow buttons to enter the Reset Password; press the *Select* button.
4. Press the *Select* button to find the value you want to reset.
5. Press either arrow key to change from “no” to “yes.”
6. Repeat steps 4 and 5 until all desired resets have been made.
7. After enabling all desired resets, press the *Mode* button. The display reads “RESET NOW? NO.”
8. To reject resets, press the *Select* button once.
9. To accept resets, press either arrow button to change “NO” to “YES.” Then press the *Select* button. You’ll see a brief message: “Resetting, Please Wait...” as the changes are made.

① Demand values available on models PM-620 and PM-650.

② Min/max values available on model PM-650 only.

VIEWING DIAGNOSTIC INFORMATION

To view diagnostic information via the display, follow these steps:

1. Press the *Mode* button until “Diagnostics” is displayed.
2. Press the *Select* button to enter the Diagnostics mode. As you continue to press the *Select* button, you’ll scroll through these screens: Model Number, Serial Number, and four F/W (firmware operating) Version screens.
3. Press the *Select* button again to go into the register read-only screen.
4. Press the arrow keys to scroll through available registers.
5. Press the *Modes* button to return to the modes list.

Refer to **Appendix F—Register List** for additional register information.

USING DISPLAY MODES

The general procedure for displaying data is as follows:

1. Press the *Mode* button to scroll to one of the six available display modes (Summary, Power, Energy, Demand^①, Power Quality^①, or Min/Max^②).
2. Press the *Select* button to select a mode.
3. Press arrow buttons to scroll through metered values.

SETTING UP ONBOARD ALARMS (PM-650 ONLY)

To set up alarming via the display, follow these steps:

1. Press the *Mode* button until “Alarm Setup” is displayed.
2. Press the *Select* button to enter the Alarm Setup mode. The display shows the password prompt.
3. Use the arrow buttons to enter the password (factory default = 0); press the *Select* button.
4. Use the arrow keys to scroll through the available alarms. When you reach the desired alarm, press the *Select* button.
5. Press either arrow key to change from “Disabled” to “Enabled”; press the *Select* button.
6. The display shows the appropriate scale factor for the pickup value. Multiply the desired pickup value by the scale factor shown on the screen (see **Scaling Alarm Setpoints** in **Appendix I—Alarm Setup** for an explanation of scale factors); press the *Select* button.
7. Use the arrow keys to increase or decrease the displayed value until the desired scaled pickup value is reached; press the *Select* button.

^① PM-620 and PM-650.

^② PM-650 only.

8. Use the arrow keys to increase or decrease the displayed value until the desired pickup delay is reached; press the *Select* button.
9. The display shows the appropriate scale factor for the dropout value. Multiply the desired dropout value by the scale factor shown on the screen; press the *Select* button.
10. Use the arrow keys to increase or decrease the displayed value until the desired scaled dropout value is reached; press the *Select* button.
11. Use the arrow keys to increase or decrease the displayed value until the desired dropout delay is reached; press the *Select* button.
12. Use the arrow keys to select either “Output: Enabled” or “Output: Disabled”; press the *Select* button.

Note: The output selection is not available if the KYZ output has been enabled in the Setup mode.

13. Repeat steps 4–12 above for each additional alarm that you’d like to set up.
14. Press the *Mode* button.
15. To save the changes you’ve just made, press the up arrow button to change from “No” to “Yes.” Then press the *Select* button.

To discard the changes, press the *Select* button while “No” is displayed. The Power Meter will reset.

VIEWING ACTIVE ALARMS (PM-650 ONLY)

To view the active alarms, follow these steps:

1. Press the *Mode* button until “Alarm Log” is displayed.
2. Press the *Select* button to enter the alarm log.
3. Use the arrow keys to scroll through the alarms. The last 10 alarms are listed, starting with the most recent alarm. Alarms that are currently active will flash. To acknowledge the alarms, press the *Mode* key.
4. Use the arrow keys to change from “No” to “Yes.”
5. Press the *Select* button. The screen will flash “Acknowledging Alarms.” The Power Meter returns to “Alarm Log” mode.

CHAPTER 8—METERING CAPABILITIES

REAL-TIME READINGS

The power meter measures currents and voltages and reports rms values for all three phases and a calculated neutral current^①. In addition, the power meter calculates true power factor, real power, reactive power, and more. Table 8-1 lists the real-time readings and their reportable ranges.

Table 8-1
Real-Time Readings

Real-Time Reading	Reportable Range
Current	
Per-Phase	0 to 32,767 A
Neutral ^①	0 to 32,767 A
Voltage	
Line-to-Line, Per-Phase	0 to 3,276,700 V
Line-to-Neutral, Per-Phase	0 to 3,276,700 V
Real Power	
3-Phase Total	0 to +/- 3,276.70 MW
Per-Phase	0 to +/- 3,276.70 MW
Reactive Power	
3-Phase Total	0 to +/- 3,276.70 MVAr
Per-Phase	0 to +/- 3,276.70 MVAr
Apparent Power	
3-Phase Total	0 to 3,276.70 MVA
Per-Phase	0 to 3,276.70 MVA
Power Factor (True)	
3-Phase Total	-0.200 to 1.000 to +0.200
Per-Phase	-0.200 to 1.000 to +0.200
Frequency	
50/60 Hz	45.00 to 66.00 Hz

MIN/MAX VALUES (PM-650 ONLY)

The power meter stores the following minimum and maximum values in nonvolatile memory:

- Frequency
- Current Phase A, B, C, and Neutral
- Voltage Phase A, Phase B, Phase C, A-B, B-C, C-A
- Power Factor Phase A, Phase B, Phase C, 3-Phase
- kW Phase A, Phase B, Phase C, 3-Phase Total
- kVAr Phase A, Phase B, Phase C, 3-Phase Total

^① PM-620 and PM-650.

- kVA Phase A, Phase B, Phase C, 3-Phase Total
- THD/thd Current Phase A, Phase B, Phase C
- THD/thd Voltage Phase A, Phase B, Phase C

You can view these values using the power meter display, and reset them using the Reset mode (see **Performing Resets** in **Chapter 7**).

Using POWERLOGIC application software you can:

- view all min/max values
- upload min/max values from the power meter and save them to disk
- reset min/max values

For instructions on viewing, saving, and resetting min/max data using POWERLOGIC software, refer to the instruction bulletin included with the software.

POWER FACTOR MIN/MAX CONVENTIONS

All running min/max values, with the exception of power factor, are arithmetic minimums and maximums. For example, the minimum phase A–B voltage is simply the lowest value in the range 0 to 3,276,700 V that has occurred since the min/max values were last reset. In contrast, power factor min/max values—since the meter’s midpoint is unity—are not true arithmetic minimums and maximums. Instead, the minimum value represents the measurement closest to -0 on a continuous scale of -0 to 1.00 to $+0$. The maximum value is the measurement closest to $+0$ on the same scale.

Figure 8-1 shows the min/max values in a typical environment, assuming a positive power flow. In figure 8-1, the minimum power factor is $-.7$ (lagging) and the maximum is $.8$ (leading). It is important to note that the minimum power factor need not be lagging, and the maximum power factor need not be leading. For example, if the power factor values ranged from $-.75$ to $-.95$, then the minimum power factor would be $-.75$ (lagging) and the maximum power factor would be $-.95$ (lagging). Likewise, if the power factor ranged from $+.9$ to $+.95$, the minimum would be $+.95$ (leading) and the maximum would be $+.90$ (leading).

See **Changing the VAR Sign Convention** in **Appendix E** for instructions on changing the sign convention over the communications link.

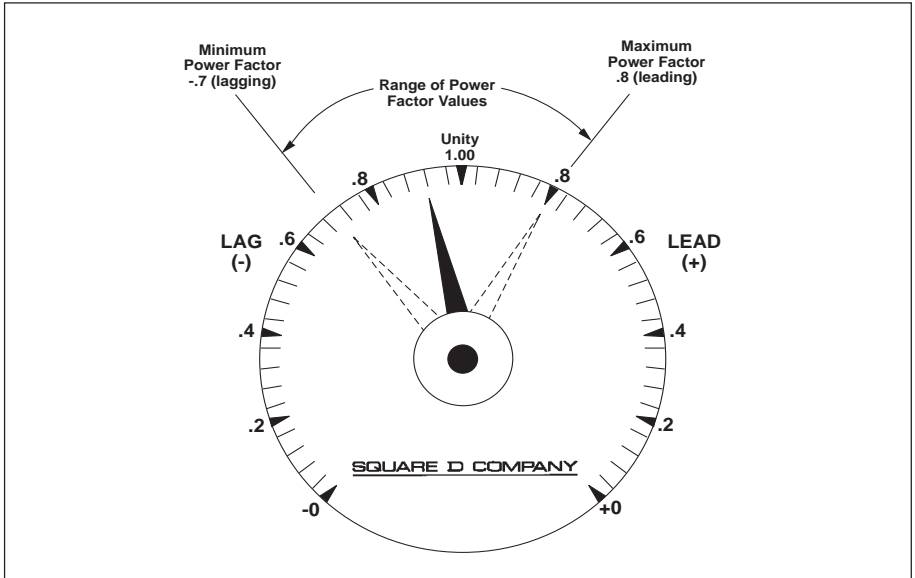

Figure 8-1: Power factor min/max example

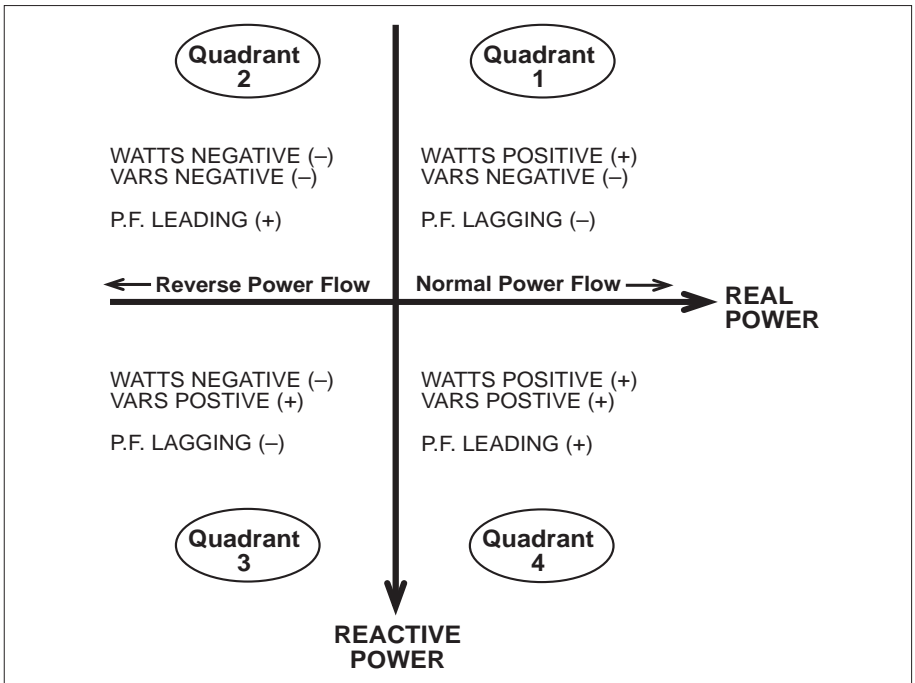

Figure 8-2: Default VAR sign convention

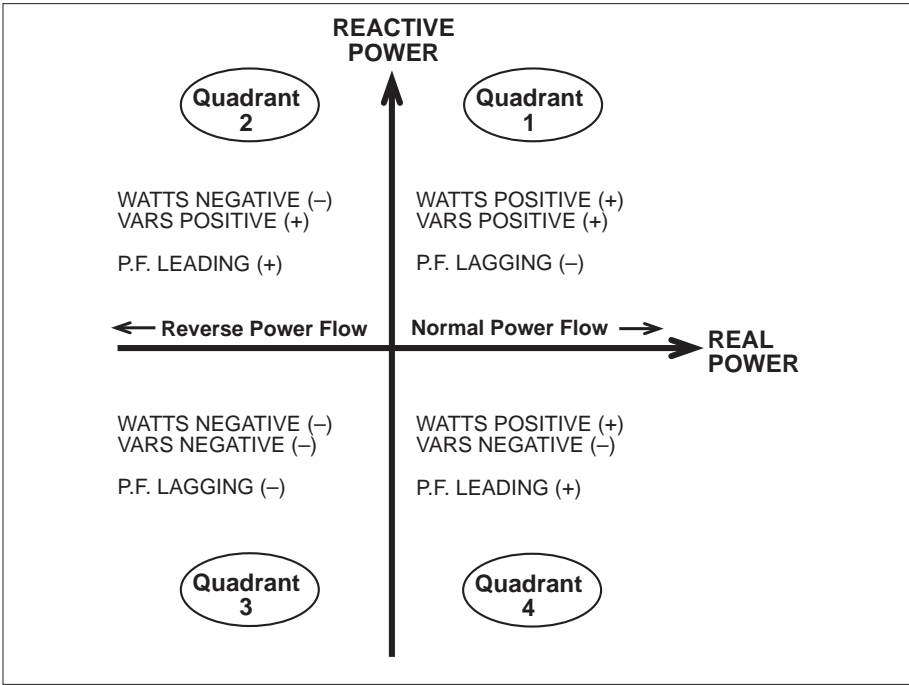

Figure 8-3: Alternate VAR sign convention

ENERGY READINGS

The power meter provides 3-phase total energy values for kWh, kVARh, and kVAh (table 8-2). These values can be displayed on the power meter display, or read over the communications link. In the default mode (unsigned), the power meter accumulates energy as positive, regardless of the direction of power flow (i.e., the energy value increases, even during reverse power flow as in a tie breaker application).

Using POWERLOGIC® System Manager™ Software *SMS-3000*, *SMS-1500*, or *PMX-1500*, the power meter can be configured to accumulate kWh and kVARh in one of three additional modes: signed, energy in, and energy out. In signed mode, the power meter considers the direction of power flow, allowing the accumulated energy magnitude to both increase and decrease. The power meter can also be configured to accumulate kWh and kVARh as either energy into the load only or energy out of the load only. The default accumulation mode is unsigned (absolute).

The power meter also calculates a 3-phase total apparent energy value. All energy values are stored in nonvolatile memory.

Table 8-2
Energy Readings

Energy Reading, 3-Phase	Reportable Range
Accumulated Energy	
Real (Signed/Absolute/In/Out)	0 to 9,999,999,999,999,999 Wh
Reactive (Signed/Absolute/In/Out)	0 to 9,999,999,999,999,999 VARh
Apparent	0 to 9,999,999,999,999,999 VAh

POWER ANALYSIS VALUES

The power meter provides power analysis values that can be used to detect power quality problems, diagnose wiring problems, and more. Table 8-3 summarizes the power analysis values.

Table 8-3
Power Analysis Values

Value	Reportable Range
THD-Voltage, Current (per phase) ①	0 to 3,276.7%
Fundamental Voltages (per phase) ②	
Magnitude	0 to 3,276,700 V
Angle	0.0 to 359.9°
Fundamental Currents (per phase) ②	
Magnitude	0 to 32,767 A
Angle	0.0 to 359.9°

① PM-620 and PM-650.

② Via communications only.

THD—Total Harmonic Distortion (THD) is a quick measure of the total distortion present in a waveform. It provides a general indication of the “quality” of a waveform. Power meter models PM-620 and PM-650 use the following equation to calculate THD:

$$\text{THD} = \frac{\sqrt{H_2^2 + H_3^2 + H_4^2 + \dots}}{H_1} \times 100\%$$

thd—An alternate method for calculating Total Harmonic Distortion, used widely in Europe. Power meter models PM-620 and PM-650 use the following equation to calculate thd:

$$\text{thd} = \frac{\sqrt{H_2^2 + H_3^2 + H_4^2 + \dots}}{\text{Total rms}} \times 100\%$$

DEMAND READINGS (PM-620 AND PM-650 ONLY)

Power meter models PM-620 and PM-650 provides both current and power demand readings (table 8-4).

Table 8-4
Demand Readings

Demand Reading	Reportable Range
Demand Current, Per-Phase & Neutral	
Present	0 to 32,767 A
Peak	0 to 32,767 A
Demand Real Power, 3Ø Total	
Present	0 to +/-3,276.70 MW
Peak	0 to +/-3,276.70 MW
Demand Reactive Power, 3Ø Total	
Present	0 to +/-3,276.70 MVAr
Peak	0 to +/-3,276.70 MVAr
Demand Apparent Power, 3Ø Total	
Present	0 to 3,276.70 MVA
Peak	0 to 3,276.70 MVA
Predicted Real Power Demand ①②	0 to ±32,767 kW ③
Predicted Reactive Power Demand ①②	0 to 32,767 kVAr ③
Predicted Apparent Power Demand ①②	0 to 32,767 KVA ③

① PM-650 only.

② Via communications only.

③ 3-phase total.

Demand Power Calculation Methods

To be compatible with electric utility billing practices, the power meter provides the following types of demand power calculations:

- Sliding Block Interval Demand (PM-620 and PM-650 only)
- Block Interval Demand with Rolling Subinterval (PM-650 only)
- Synch to Comms (PM-650 only)

Block interval demand can be set up using the power meter display. Block interval demand with a subinterval and sync to comms must be set up over the communications link. A brief description of these three demand power calculations follows.

Sliding Block Interval Demand

The block interval demand mode supports a sliding block interval calculation. The default interval is 15 minutes.

In the sliding block interval mode, you can select a demand interval from 1 to 60 minutes in 1-minute increments. (The demand interval is set in the Setup Mode. See Chapter 7 for details.) If you specify an interval of 1 to 15 minutes, the demand calculation updates every 15 seconds on a sliding window basis.

If the interval is between 16 and 60 minutes, the demand calculation updates every 60 seconds on a sliding window basis. The present demand value displayed by the power meter is the value for the last completed interval.

Block Interval Demand with Subinterval Option (PM-650 Only)

When using POWERLOGIC software, you must select both a block interval and a subinterval length. The default subinterval length is 0 minutes. At this default setting, the sliding block interval calculation described above is performed. If you set the subinterval to the value of the block interval, a fixed block calculation is performed and the demand calculation is updated every interval. If you set the subinterval to a value other than 0 or the block interval value, the power meter performs a rolling block demand calculation and updates the demand calculation at every subinterval.

Synch to Comms (PM-650 Only)

If you set the demand to 0 using POWERLOGIC software, the synch to comms demand calculation is used. See **Appendix E** for more information.

Predicted Demand (PM-650 Only)

Predicted demand is the average rate of power use during the most recent one-minute interval. It is called predicted demand because the best estimate of future power use is the power used in the most recent past.

The power meter calculates predicted demand for kW, kVAr, and kVA, updating the readings every 15 seconds. The predicted demand value does not predict the outcome of the present demand interval. Rather, since it represents only the most recent 1 minute interval, it is more responsive to recent increases or decreases in power than the present demand calculation.

Peak Demand

The power meter maintains, in nonvolatile memory, a “peak demand” for each average demand current and average demand power value. It also stores the date and time of each peak demand. In addition to the peak demand, the power meter stores the coinciding average (demand) 3-phase power factor. The average 3-phase power factor is defined as “demand kW/demand kVA” for the peak demand interval.

Peak demand values can be reset using the power meter display, or over the communications link using POWERLOGIC application software. To reset peak demand values using the power meter display, see **Performing Resets** on page 54.

KYZ PULSE OUTPUT

This section describes the power meter's pulse output capability. For wiring instructions, see **Chapter 5—Wiring**. The KYZ output is a Form-C contact with a maximum rating of 96 mA.

Calculating the Pulse Constant

This section shows an example of how to calculate the pulse constant (in this case, a watt-hour-per-pulse value). To calculate this value, first determine the highest kW value you can expect and the required pulse rate. In this example, the following assumptions are made:

- The metered load should not exceed 1500 kW.
- The KYZ pulses should come in at about two pulses per second at full scale.

Step 1: Translate 1500 kW load into kWh/second.

$$(1500 \text{ kW}) (1 \text{ Hr}) = 1500 \text{ kWh}$$

$$\frac{(1500 \text{ kWh})}{1 \text{ hour}} = \frac{\text{"X" kWh}}{1 \text{ second}}$$

$$\frac{(1500 \text{ kWh})}{3600 \text{ seconds}} = \frac{\text{"X" kWh}}{1 \text{ second}}$$

$$X = 1500/3600 = 0.4167 \text{ kWh/second}$$

Step 2: Calculate the kWh required per pulse.

$$\frac{0.4167 \text{ kWh/second}}{2 \text{ pulses/second}} = 0.2084 \text{ kWh/pulse}$$

Step 3: Round to the nearest hundredth, since the power meter accepts 0.01 kWh increments.

$$K_e = 0.21 \text{ kWh/pulse}$$

Summary:

- 3-wire basis—0.21 kWh/pulse will provide approximately 2 pulses per second at full scale.
- 2-wire basis—0.11 kWh/pulse will provide approximately 2 pulses per second at full scale. (To convert to the kWh/pulse required on a 2-wire basis, divide K_e by 2. This is necessary since the power meter Form-C relay generates two pulses—KY and KZ—for every pulse that is counted on a 2-wire basis.)

CHAPTER 9—ONBOARD ALARMING (PM-650 ONLY)

The power meter 650 has 30 alarm conditions available onboard, including over/under conditions and unbalance conditions (See **Alarm Conditions and Alarm Codes** in **Appendix I** for a complete list of alarm conditions.) The power meter maintains a counter for each alarm to keep track of the total number of occurrences.

These alarm conditions are tools that enable the power meter to execute tasks automatically. Using POWERLOGIC application software, each alarm condition can be assigned one or more of the following tasks:

- Force data log entries in the data log file
- Operate the KYZ relay output

SETPOINT-DRIVEN ALARMS

All of the alarm conditions require that you define the following setpoints:

- Pickup Setpoint
- Pickup Delay (in seconds)
- Dropout Setpoint
- Dropout Delay (in seconds)

For instructions on setting up alarm/relay functions from the power meter display, see **Setting Up Onboard Alarms** on page 55.

Figure 9-1 below illustrates how the power meter 650 handles setpoint-driven alarms.

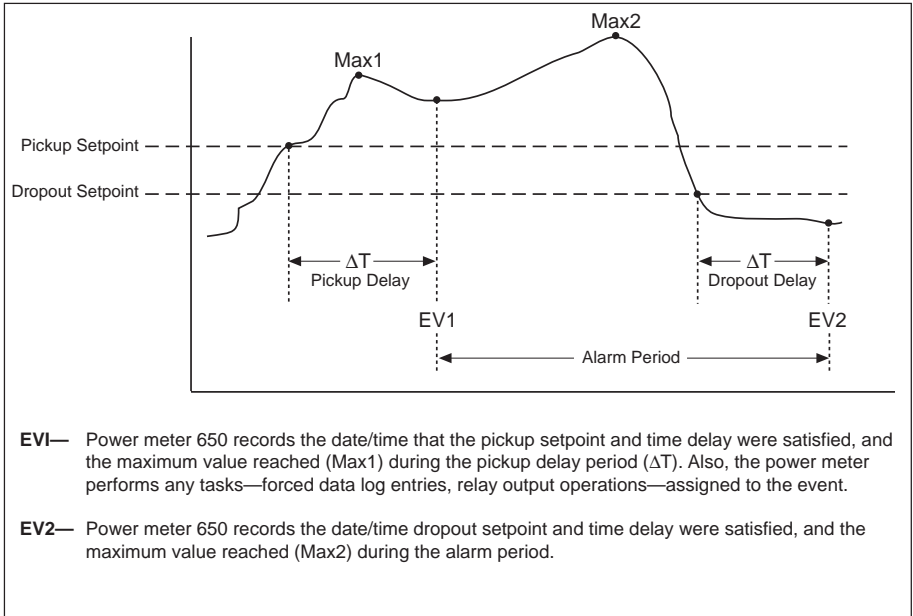

Figure 9-1: How the power meter handles setpoint-driven alarms

Figure 9-2 shows the event log entries for figure 9-1 displayed by POWERLOGIC application software.

On-Board Event Log:pm650						
	Date/Time	Event	Value	Condition	Forced Log Entry	
EV1	21 08/23/95 06:49:22.000 AM	Over Current B	61	Pickup	1,	
	22 08/23/95 06:49:22.000 AM	Over Current C	48	Pickup	1,	
	23 08/23/95 06:49:26.000 AM	Over Current C	48	Dropout		
EV2	24 08/23/95 06:49:37.000 AM	Over Current B	61	Dropout		

Max1 points to the value 61 in row 21.
 Max2 points to the value 61 in row 24.

Figure 9-2: Sample event log entries

SETPOINT-CONTROLLED RELAY FUNCTIONS

The KYZ output can be used to operate an alarm horn or bell to annunciate the alarm condition or as an input into a building management system. For instructions on wiring the KYZ output as an alarm contact, see Chapter 5—Wiring.

Undervoltage

- Pickup and dropout setpoints are entered in volts. Very large values may require scale factors. Refer to **Appendix I—Alarm Setup**.
- The per-phase overvoltage alarm occurs when the per-phase voltage is equal to or above the pickup setpoint for the specified pickup delay period (in seconds).
- When the overvoltage alarm occurs, the power meter operates the KYZ output (if the output is enabled).
- The relay remains closed until the overvoltage alarm clears. The alarm clears when the phase voltage remains below the dropout setpoint for the specified dropout delay period.

Unbalance Current:

- Pickup and dropout setpoints are entered in tenths of percent, based on the percentage difference between each phase current with respect to the average of all phase currents. For example, enter an unbalance of 16.0% as 160.
- The unbalance current alarm occurs when the phase current deviates from the average of the phase currents, by the percentage pickup setpoint, for the specified pickup delay (in seconds).
- When the unbalance current alarm occurs, the power meter operates the KYZ output (if the output is enabled).
- The relay remains closed until the unbalance current alarm clears. The alarm clears when the percentage difference between the phase current and the average of all phases remains below the dropout setpoint for the specified dropout delay period.

Unbalance Voltage

Pickup and dropout setpoints are entered in tenths of percent, based on the percentage difference between each phase voltage with respect to the average of all phase voltages. For example, enter an unbalance of 16.0% as 160.

- The unbalance voltage alarm occurs when the phase voltage deviates from the average of the phase voltages, by the percentage pickup setpoint, for the specified pickup delay (in seconds).
- When the unbalance voltage alarm occurs, the power meter operates the KYZ output (if the output is enabled).
- The relay remains closed until the unbalance voltage alarm clears. The unbalance voltage alarm clears when the percentage difference between the phase voltage and the average of all phases remains below the dropout setpoint for the specified dropout delay period.

CHAPTER 10—LOGGING (PM-650 ONLY)

ALARM LOG

The PM-650 has an alarm log viewable only from the power meter display. The alarm log stores the last 10 alarms that occurred and indicates whether each of those alarms has been acknowledged. The alarm log and event log are two separate logs.

EVENT LOG

Power meter model 650 also provides an event log to record onboard events. (An event occurs when the pickup or dropout setpoint of an alarm is reached; see **Chapter 9** for more information.) The event log holds a user-configurable number of alarm events in FIFO (first-in-first-out) or Fill/Hold order. The event log is factory pre-configured to hold 20 events. Using POWERLOGIC application software, you can upload the event log for viewing, save it to disk, and clear the power meter's event log memory.

DATA LOG

The PM-650 is equipped with nonvolatile memory for storing meter readings at regular intervals. One data log is provided for user configuration. The following items can be configured for the data log file:

- Logging interval—1 minute to 24 hours in 1 minute increments
- Offset time
- First-In-First-Out (FIFO), or Fill & Hold
- Values to be logged

The data log is pre-configured to log each of the following hourly:

- Per-phase quantities: present current demand (including neutral) and line-to-line voltages
- 3-phase quantities: true power factor, kW demand total, kVA demand total, and kVA demand total

For instructions on setting up and clearing data log files, refer to the POWERLOGIC application software instruction bulletin.

ALARM-DRIVEN DATA LOG ENTRIES

Using POWERLOGIC application software, you can select an alarm condition such as "Overcurrent Phase A" and set up the power meter to force data log entries into the log file each time the alarm condition occurs.

STORAGE CONSIDERATIONS

The PM-650 has 1K of nonvolatile memory allocated for the event log and the data log. See **Appendix J—Calculating Log File Size** for additional information on the event and data logs.

APPENDIX A—SPECIFICATIONS

Metering Specifications

Current Inputs

Current Range	0–10.0 A ac
Nominal Current	5 A ac

Voltage Inputs

Voltage Range (line to line)	35–600 Vac
Voltage Range (line to neutral)	20–347 Vac
Nominal Voltage (typical)	208/120, 480/277, 600/347 Vrms
Frequency Range (50/60 Hz)	45 to 66 Hz

Harmonic Response—Voltage, Current

Frequency 45–65 Hz	31st harmonic
--------------------------	---------------

Accuracy

Current ^①	±0.25% reading ^{②③}
Voltage	±0.25% reading ^③
Power	±0.5% reading ^{②③}
Energy ^④	±0.5% reading ^{②③}
Demand ^④	±0.5% reading ^{②③}
Power Factor	±1.00%
Frequency 50/60 Hz	±0.02 Hz

Metering Input Electrical Specifications

Current Inputs

Nominal Full Scale	5 A
Metering Over-Range	2x
Overcurrent Withstand	500 A, 1 second
Input Impedance	1.5 milliohms
Burden	0.15 VA
Isolation	600 V

Voltage Inputs

Nominal Full Scale	208/120, 480/277, 600/347 V
Metering Over-Range	20%
Input Impedance	Greater than 2 megohms

① Any CT secondary currents less than 20 mA are reported as zero.

② From 20% nominal current to 150% nominal current.

③ For readings less than 20% nominal, add ±0.05 full scale error.

④ Satisfies applicable ANSI C12.16 revenue accuracy requirements.

Control Power Input Specifications

Input Range, ac	90–600 Vac
Burden	90 Vac–264 Vac, 10 VA 265 Vac–600 Vac, 30 VA
Frequency Range	45–66 Hz
Isolation	2000 Vac/60 seconds
Ride-through on Power Loss	100 ms at 115 Vac
Input Range, dc	100–300 Vdc
Burden	6 watts
Isolation	1000 Vdc
Ride-through on Power Loss	100 ms at 125 Vdc
Main's Supply Voltage Fluctuations	not to exceed +/- 10%

Relay Output Specifications

KYZ	96 mA max. at 240 Vac/300 Vdc
-----------	-------------------------------

Environmental Specifications (Indoor Use Only)

Operating Temperature—Meter	0 to +60°C
Operating Temperature—Display	0 to +55°C
Storage Temperature	-20 to +70°C
Humidity Rating	5–95% (non-condensing) @ 30°C
Pollution Degree	2
Installation Category	II
Altitude Rating	0 to 4,570 m (15,000 ft.)

Physical Specifications

Weight	
Module	17.6 oz. (500g)
Display	7.1 oz. (202g)
Dimensions	See Appendix B

Regulatory/Standards Compliance

Electromagnetic Interference	
Radiated	EN55011 & EN55022, FCC Part 15 Class A
Conducted	EN55011 & EN55022, FCC Part 15 Class A
Immunity	IEC 1000-4-3 Level 3
Electrostatic Discharge (Air Discharge)	IEC 1000-4-2 Level 3
Electrical Fast Transient	IEC 1000-4-4 Level 4
Immunity to Surge	IEC 1000-4-5 Level 4
Safety	CSA, UL 508, CE, EN61010-1

APPENDIX B—DIMENSIONS

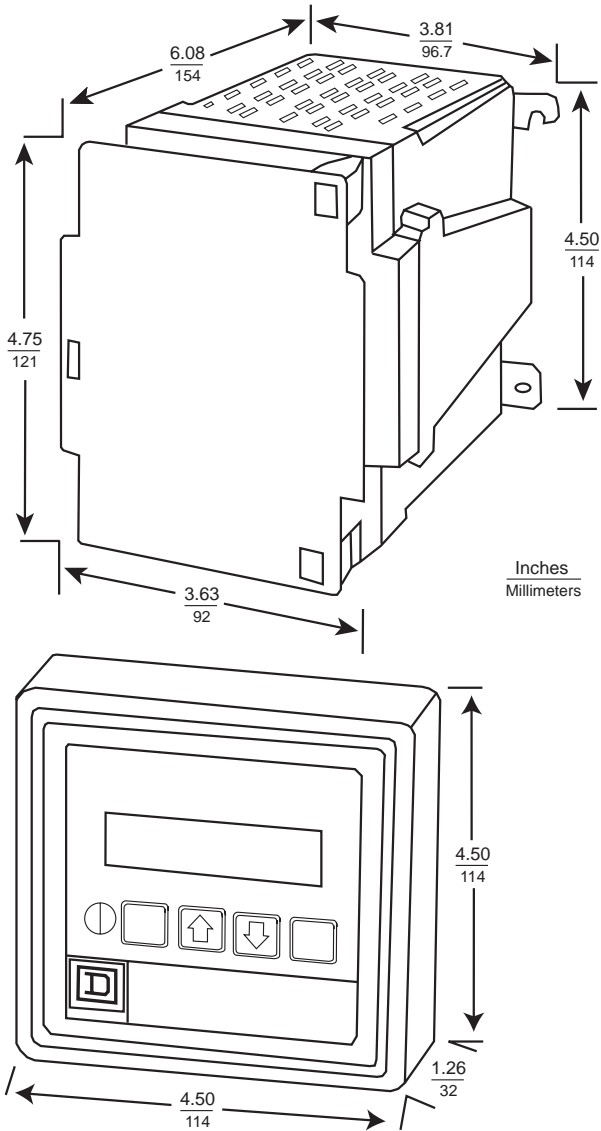

Figure B-1: Dimensions of power meter and display

APPENDIX C—COMMUNICATION CABLE PINOUTS

CAB-107

Power Meter Terminal	Male DB-9 Connector
IN- (4)—White	1
IN+ (5)—Green	2
OUT- (2)—Black	3
OUT+ (3)—Red	4
	5
	6
	7
	8
SHLD (1) Shield	9

CAB-108

TXA—White	1
TXB—Green	2
RXA—Black	3
RXB—Red	4
	5
	6
	7
	8
Shield—Shield	9

CC-100

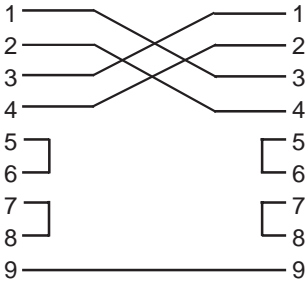

CAB-102, CAB-104

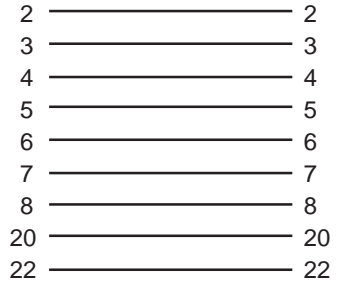

APPENDIX D—ADDITIONAL WIRING DIAGRAMS

DANGER

HAZARD OF ELECTRICAL SHOCK, BURN, OR EXPLOSION.

- Turn off all power supplying this equipment before opening the terminal shield or making connections.
- Close and snap the terminal shield before turning power on.

Failure to observe these precautions will result in death or severe personal injury!



SUPPORTED WIRING CONNECTIONS

Table D-1 on the following page describes various power systems supported by the power meter. The table also shows which power meter system type should be used (system I.D.) and how the power meter should be wired.

Figures D-1, D-2, and D-3 show CT, PT, and control power wiring. See **Chapter 5** for other wiring diagrams.

To comply with CE, see **CE Compliance**, page 22.

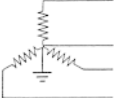
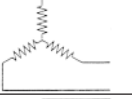
Table D-1
Power Meter System Wiring Connections

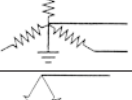
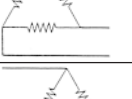
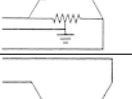
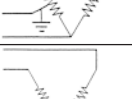
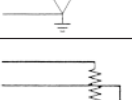
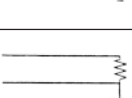
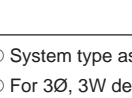
System Wiring	Power Meter System I.D. ^①	Wiring for Power Meter	Notes	
	3Ø, 4W wye grounded neutral	40	3Ø, 4W wye figure 5-6 or 5-7	
	3Ø, 3W wye	30 or 31	3Ø, 3W delta figure 5-3, 5-4, or 5-5	
	3Ø, 3W wye, grounded neutral	40	3Ø, 4W wye figure 5-6 or 5-7	1. Connect GND to neutral voltage terminal. 2. Line to neutral voltage may be unbalanced due to potential difference between GND at transformer & GND at meter.
	3Ø, 4W wye	40	3Ø, 4W wye figure 5-6 or 5-7	
	2Ø, 3W wye, grounded neutral	40	1Ø, 3W figure D-1	1. Jumper input of phase not being metered to neutral voltage input.
	3Ø, 3W delta ^②	30 or 31	3Ø, 3W delta figure 5-3	1. For ungrounded delta systems only.
	3Ø, 4W delta, grounded mid-tap	40	3Ø, 4W figure D-2	1. Per phase power factor will be determined with respect to neutral. 2. Always use 480/277 voltage range on the power meter.
	3Ø, 4W open delta, grounded mid-tap	40	3Ø, 4W figure D-2	1. Per phase power factor will be determined with respect to neutral. 2. Always use 480/277 voltage range on the power meter.
	3Ø, 3W open delta, corner grounded	30 or 31	3Ø, 3W delta figure 5-4 or 5-5	1. Wire grounded corner into B phase voltage input.
	1Ø, 3W grounded mid-tap	40	1Ø, 3W figure D-1	1. B phase readings will be zero. 2. Always use 208/120 voltage range on the power meter.
	1Ø, 2W grounded end of phase mid-tap	40	1Ø, 3W figure D-1	1. Use only L ₁ -N PT and L ₁ CT. 2. B & C phase readings will be zero. 3. Always use 208/120 voltage range on the power meter.

① System type as shown on power meter setup screen.

② For 3Ø, 3W delta corner-grounded applications, install two L-L rated PTs as shown in figures 5-4 and 5-5.

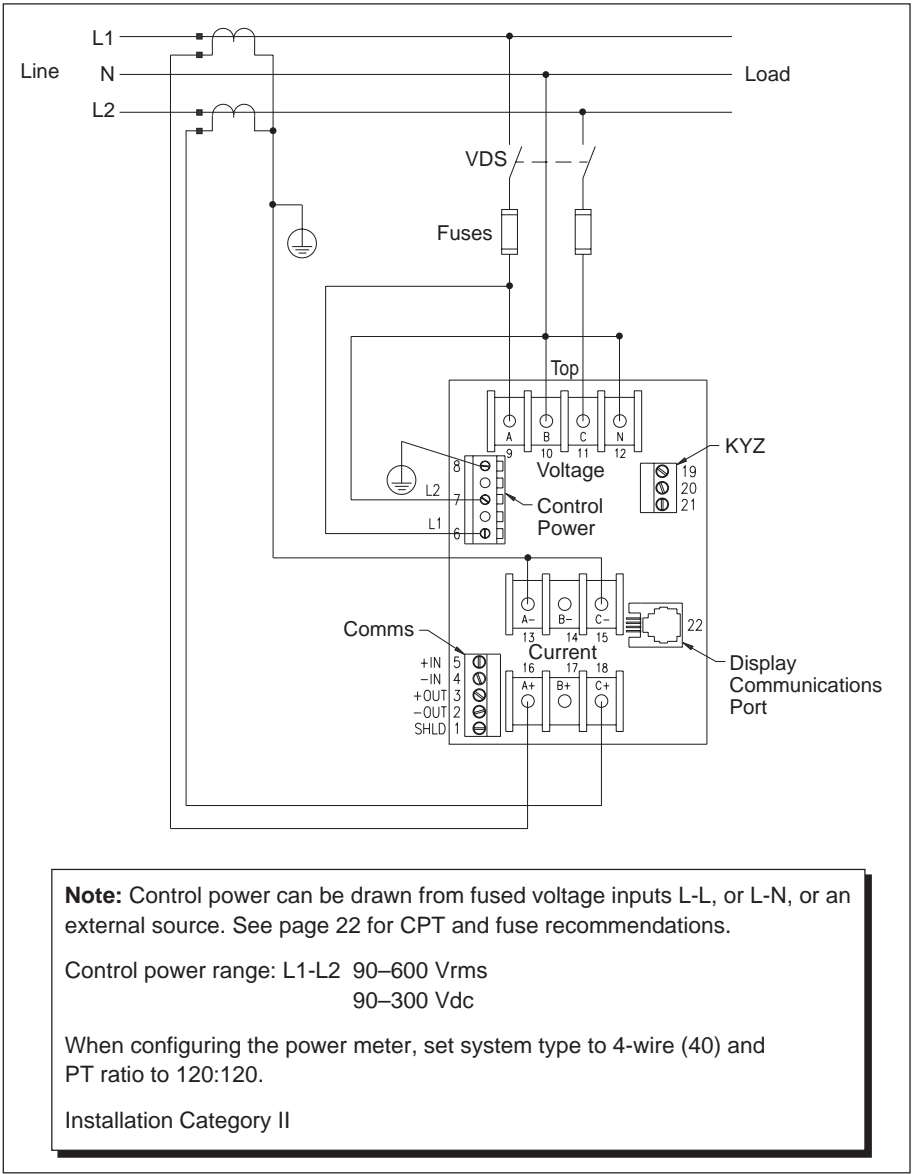

Note: Control power can be drawn from fused voltage inputs L-L, or L-N, or an external source. See page 22 for CPT and fuse recommendations.

Control power range: L1-L2 90–600 Vrms
 90–300 Vdc

When configuring the power meter, set system type to 4-wire (40) and PT ratio to 120:120.

Installation Category II

Figure D-1: 240/120 V 1-phase, 3-wire direct voltage connection with 2 CTs

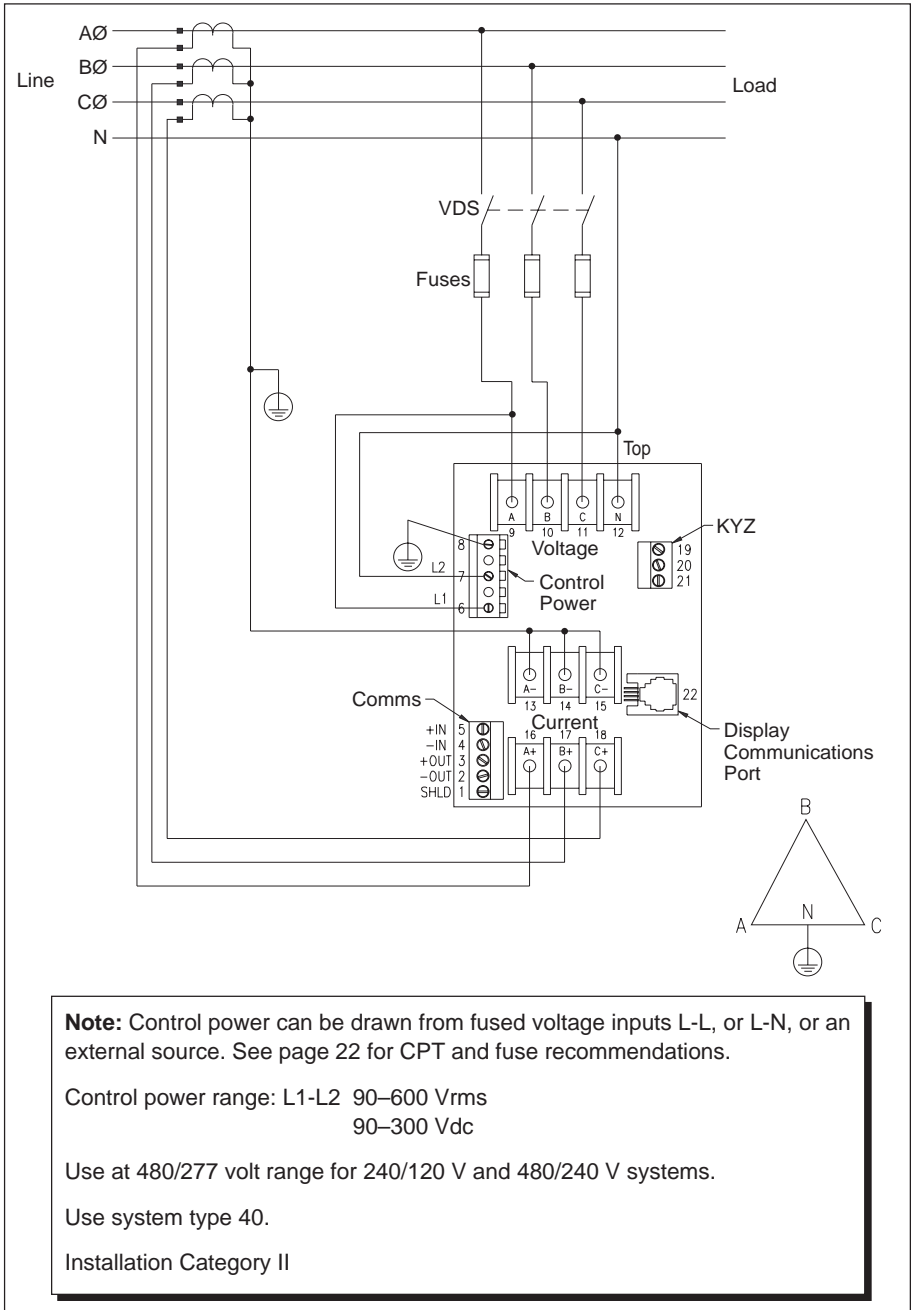
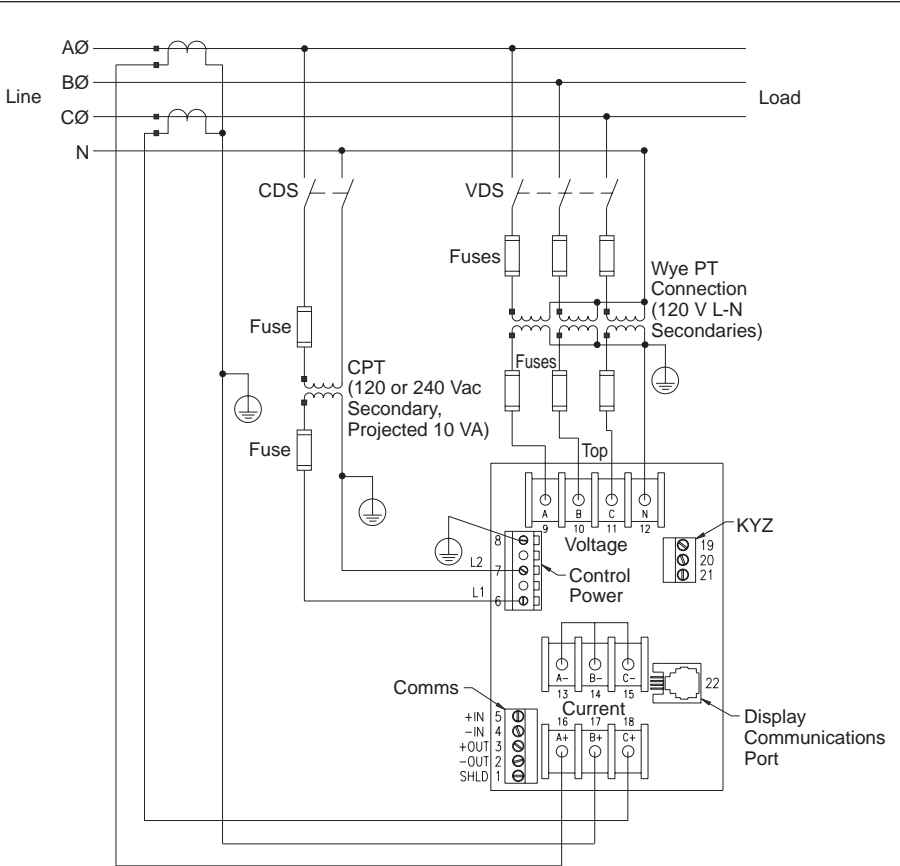

Figure D-2: 3-phase, 4-wire delta with 3 PTs and 3 CTs



Note: Control power can be drawn from fused voltage inputs L-L, or L-N, or an external source. See page 22 for CPT and fuse recommendations.

Control power range: L1-L2 90–600 Vrms
 90–300 Vdc

Installation Category II

Figure D-3: 3-phase, 4-wire wye, 3-wire load with 3 PTs and 2 CTs

APPENDIX E—USING THE COMMAND INTERFACE

RESETTING DEMAND AND ENERGY VIA COMMUNICATIONS

Using System Manager Software (*SMS-3000*, *SMS-1500*, or *PMX-1500*), you can reset Peak Demand Currents, Peak Demand Powers, Min/Max and the associated power factors. You can also clear accumulated energies. If you are not using one of these software packages, you can perform these functions via communications by entering the desired command code (see below) to register 7700.

Command Code	Description
4110	Reset min/max (PM-650 only)
5110	Reset peak demand currents
5120	Reset peak demand powers and associated average power factors
6210	Clear all accumulated energies

CHANGING THE VAR SIGN CONVENTION

The power meter offers two VAR sign conventions (see figures 8-2 and 8-3 in **Chapter 8**). The procedures below tell how to change the sign convention via communications.

To change to the alternate sign convention, complete the following steps:

1. (SY/MAX or POWERLOGIC protocol only) Read register 7715.
2. Read register 2028, the value of the system password.
3. Write the value in register 2028 into register 7721.
4. Write the decimal value 2020 into register 7720.
5. Change to binary mode and read register 7755.
6. Change bit 0, the least significant or right-most bit, to a 1 and write the new value back to register 7755.
7. Change back to decimal mode and read register 2028.
8. Write the value of register 2028 into register 7721.
9. Write the decimal value 2050 into register 7720. The changes are saved and the power meter resets.

To return to the default sign convention, complete the following steps:

1. (SY/MAX or POWERLOGIC protocol only) Read register 7715.
2. Read register 2028, the value of the system password.

3. Write the value in register 2028 into register 7721.
4. Write the decimal value 2020 into register 7720.
5. Change to binary mode and read register 7755.
6. Change bit 0, the least significant or right-most bit, to a 0 and write the new value back to register 7755.
7. Change back to decimal mode and read register 2028.
8. Write the value of register 2028 into register 7721.
9. Write the decimal value 2050 into register 7720. The changes are saved and the power meter resets.

SYNCH TO COMMS (PM-650 Only)

Using command 5910, it is possible to synchronize the demand intervals of multiple meters on a communications network. For example, a PLC input could be monitoring the utility revenue meter's end-of-demand-interval pulse. The PLC can be programmed to issue command 5910 to multiple meters whenever the utility meter starts a new demand interval. This technique causes the demand readings of each meter to be calculated over the same fixed block interval.

Enter the command code to register 7700 via communications.

<u>Command Code</u>	<u>Description</u>
5910	Start a new demand interval (if demand interval is 0)

APPENDIX F—REGISTER LIST

Reg. No. ①	Register Name	Units	Range
REAL TIME METERED VALUES			
1000	Update Interval	1000ths of a second	0 to 10,000
1001	Frequency	.01 Hertz/Scale Factor F	4500 to 6600 (45–66Hz) Range
1002	Unused		
1003	Current, Phase A	Amps/Scale Factor A	0 to 32,767
1004	Current, Phase B	Amps/Scale Factor A	0 to 32,767
1005	Current, Phase C	Amps/Scale Factor A	0 to 32,767
1006 ②	Current, Calculated Neutral	Amps/Scale Factor A	0 to 32,767
1007– 1009	Unused		
1010	Current Unbalance, Phase A	Percent in 10ths	0 to ±1000
1011	Current Unbalance, Phase B	Percent in 10ths	0 to ±1000
1012	Current Unbalance, Phase C	Percent in 10ths	0 to ±1000
1013	Current Unbalance, Worst	Percent in 10ths	0 to ±1000
1014	Voltage, Phase A to B	Volts/Scale Factor D	0 to 32,767
1015	Voltage, Phase B to C	Volts/Scale Factor D	0 to 32,767
1016	Voltage, Phase C to A	Volts/Scale Factor D	0 to 32,767
1017	Unused		
1018	Voltage, Phase A to Neutral	Volts/Scale Factor D	0 to 32,767

① These registers can be used with POWERLOGIC, Modbus, or Jbus protocols. Although POWERLOGIC and Jbus protocols use a zero-based register addressing convention and Modbus uses a one-based register addressing convention, the power meter, when configured for Modbus communications, *automatically compensates* for the Modbus offset of one. Regard all registers as holding registers where a 30,000 or 40,000 offset can be used (e.g., Current, Phase A = 31,003 or 41,003).

② PM-620 and PM-650 only.

Reg. No. ①	Register Name	Units	Range
1019	Voltage, Phase B to Neutral	Volts/Scale Factor D	0 to 32,767
1020	Voltage, Phase C to Neutral	Volts/Scale Factor D	0 to 32,767
1021	Reserved		
1022	Voltage Unbalance, Phase A-B	Percent in 10ths	0 to ±1000
1023	Voltage Unbalance, Phase B-C	Percent in 10ths	0 to ±1000
1024	Voltage Unbalance, Phase C-A	Percent in 10ths	0 to ±1000
1025	Voltage Unbalance, L-L Worst	Percent in 10ths	0 to ±1000
1026	Voltage Unbalance, Phase A	Percent in 10ths	0 to ±1000
1027	Voltage Unbalance, Phase B	Percent in 10ths	0 to ±1000
1028	Voltage Unbalance, Phase C	Percent in 10ths	0 to ±1000
1029	Voltage Unbalance, L-N Worst	Percent in 10ths	0 to ±1000
1030	Reserved		
1031	True Power Factor, Phase A	In 1000ths	-100 to +1000 to +100
1032	True Power Factor, Phase B	In 1000ths	-100 to +1000 to +100
1033	True Power Factor, Phase C	In 1000ths	-100 to +1000 to +100
1034	True Power Factor, 3-Phase Total	In 1000ths	-100 to +1000 to +100
1035–1038	Unused		
1039	Real Power, Phase A	kW/Scale Factor E	0 to ±32,767
1040	Real Power, Phase B	kW/Scale Factor E	0 to ±32,767

① These registers can be used with POWERLOGIC, Modbus, or Jbus protocols. Although POWERLOGIC and Jbus protocols use a zero-based register addressing convention and Modbus uses a one-based register addressing convention, the power meter, when configured for Modbus communications, *automatically compensates* for the Modbus offset of one. Regard all registers as holding registers where a 30,000 or 40,000 offset can be used (e.g., Current, Phase A = 31,003 or 41,003).

Reg. No. ①	Register Name	Units	Range
1041	Real Power, Phase C	kW/Scale Factor E	0 to $\pm 32,767$
1042	Real Power, 3-Phase Total	kW/Scale Factor E	0 to $\pm 32,767$
1043	Reactive Power, Phase A	kVAr/Scale Factor E	0 to $\pm 32,767$
1044	Reactive Power, Phase B	kVAr/Scale Factor E	0 to $\pm 32,767$
1045	Reactive Power, Phase C	kVAr/Scale Factor E	0 to $\pm 32,767$
1046	Reactive Power, 3-Phase Total	kVAr/Scale Factor E	0 to $\pm 32,767$
1047	Apparent Power, Phase A	kVA/Scale Factor E	0 to $+32,767$
1048	Apparent Power, Phase B	kVA/Scale Factor E	0 to $+32,767$
1049	Apparent Power, Phase C	kVA/Scale Factor E	0 to $+32,767$
1050	Apparent Power, 3-Phase Total	kVA/Scale Factor E	0 to $+32,767$
1051 ②	THD/thd A Current	% in 10ths	0 to 10,000
1052 ②	THD/thd B Current	% in 10ths	0 to 10,000
1053 ②	THD/thd C Current	% in 10ths	0 to 10,000
1054	Reserved		
1055 ②	THD/thd A Voltage	% in 10ths	0 to 10,000
1056 ②	THD/thd B Voltage	% in 10ths	0 to 10,000

① These registers can be used with POWERLOGIC, Modbus, or Jbus protocols. Although POWERLOGIC and Jbus protocols use a zero-based register addressing convention and Modbus uses a one-based register addressing convention, the power meter, when configured for Modbus communications, *automatically compensates* for the Modbus offset of one. Regard all registers as holding registers where a 30,000 or 40,000 offset can be used (e.g., Current, Phase A = 31,003 or 41,003).

② PM-620 and PM-650 only.

Reg. No. ①	Register Name	Units	Range
1057 ②	THD/thd C Voltage	% in 10ths	0 to 10,000
1058– 1077	Unused		
1078	A Current Fundamental RMS Magnitude	Amps/Scale Factor A	0 to 32,767
1079	A Current Fundamental Coincident Angle	10ths of Degrees	0 to 3,599
1080	B Current Fundamental RMS Magnitude	Amps/Scale Factor A	0 to 32,767
1081	B Current Fundamental Coincident Angle	10ths of Degrees	0 to 3,599
1082	C Current Fundamental RMS Magnitude	Amps/Scale Factor A	0 to 32,767
1083	C Current Fundamental Coincident Angle	10ths of Degrees	0 to 3,599
1084– 1087	Unused		
1088	A Voltage Fundamental RMS Magnitude	Volts/Scale Factor D	0 to 32,767
1089	A Voltage Fundamental Coincident Angle	10ths of Degrees	0 to 3,599
1090	B Voltage Fundamental RMS Magnitude	Volts/Scale Factor D	0 to 32,767
1091	B Voltage Fundamental Coincident Angle	10ths of Degrees	0 to 3,599

① These registers can be used with POWERLOGIC, Modbus, or Jbus protocols. Although POWERLOGIC and Jbus protocols use a zero-based register addressing convention and Modbus uses a one-based register addressing convention, the power meter, when configured for Modbus communications, *automatically compensates* for the Modbus offset of one. Regard all registers as holding registers where a 30,000 or 40,000 offset can be used (e.g., Current, Phase A = 31,003 or 41,003).

② PM-620 and PM-650 only.

Reg. No. ①	Register Name	Units	Range
1092	C Voltage Fundamental RMS Magnitude	Volts/Scale Factor D	0 to 32,767
1093	C Voltage Fundamental Coincident Angle	10ths of Degrees	0 to 3,599
1094	A-B Voltage Fundamental RMS Magnitude	Volts/Scale Factor D	0 to 32,767
1095	A-B Voltage Fundamental Coincident Angle	10ths of Degrees	0 to 3,599
1096	B-C Voltage Fundamental RMS Magnitude	Volts/Scale Factor D	0 to 32,767
1097	B-C Voltage Fundamental Coincident Angle	10ths of Degrees	0 to 3,599
1098	C-A Voltage Fundamental RMS Magnitude	Volts/Scale Factor D	0 to 32,767
1099	C-A Voltage Fundamental Coincident Angle	10ths of Degrees	0 to 3,599
1200 ②	Minimum Update Interval	In 1000ths of a second	0 to 10,000
1201 ②	Minimum Frequency	Hertz/Scale Factor F	4500 to 6600
1202 ②	Reserved		
1203 ②	Minimum Current, Phase A	Amps/Scale Factor A	0 to 32,767
1204 ②	Minimum Current, Phase B	Amps/Scale Factor A	0 to 32,767
1205 ②	Minimum Current, Phase C	Amps/Scale Factor A	0 to 32,767
1206 ②	Minimum Current Neutral, Calculated	Amps/Scale Factor A	0 to 32,767
1207 ②	Reserved		

① These registers can be used with POWERLOGIC, Modbus, or Jbus protocols. Although POWERLOGIC and Jbus protocols use a zero-based register addressing convention and Modbus uses a one-based register addressing convention, the power meter, when configured for Modbus communications, *automatically compensates* for the Modbus offset of one. Regard all registers as holding registers where a 30,000 or 40,000 offset can be used (e.g., Current, Phase A = 31,003 or 41,003).

② PM-650 only.

Reg. No. ①	Register Name	Units	Range
1208 ②	Reserved		
1209 ②	Reserved		
1210 ②	Minimum Current Unbalance, Phase A	Percent in 10ths	0 to ±1000
1211 ②	Minimum Current Unbalance, Phase B	Percent in 10ths	0 to ±1000
1212 ②	Minimum Current Unbalance, Phase C	Percent in 10ths	0 to ±1000
1213 ②	Minimum Current Unbalance, Worst	Percent in 10ths	0 to ±1000
1214 ②	Minimum Voltage, Phase A to B	Volts/Scale Factor D	0 to 32,767
1215 ②	Minimum Voltage, Phase B to C	Volts/Scale Factor D	0 to 32,767
1216 ②	Minimum Voltage, Phase C to A	Volts/Scale Factor D	0 to 32,767
1217 ②	Reserved		
1218 ②	Minimum Voltage, Phase A	Volts/Scale Factor D	0 to 32,767
1219 ②	Minimum Voltage, Phase B	Volts/Scale Factor D	0 to 32,767
1220 ②	Minimum Voltage, Phase C	Volts/Scale Factor D	0 to 32,767
1221 ②	Reserved		
1222 ②	Minimum Voltage Unbalance, Phase A-B	Percent in 10ths	0 to ±1000
1223 ②	Minimum Voltage Unbalance, Ph. B-C	Percent in 10ths	0 to ±1000
1224 ②	Minimum Voltage Unbalance, Ph. C-A	Percent in 10ths	0 to ±1000
1225 ②	Minimum Volt. Unbalance, Worst L-L	Percent in 10ths	0 to ±1000
1226 ②	Minimum Voltage Unbalance, Ph. A	Percent in 10ths	0 to ±1000
1227 ②	Minimum Voltage Unbalance, Ph. B	Percent in 10ths	0 to ±1000
1228 ②	Minimum Voltage Unbalance, Ph. C	Percent in 10ths	0 to ±1000
1229 ②	Minimum Volt. Unbalance, Worst L-N	Percent in 10ths	0 to ±1000
1230 ②	Reserved		
1231 ②	Minimum True Power Factor, Phase A	In 1000ths	-100 to +1000 to +100

① These registers can be used with POWERLOGIC, Modbus, or Jbus protocols. Although POWERLOGIC and Jbus protocols use a zero-based register addressing convention and Modbus uses a one-based register addressing convention, the power meter, when configured for Modbus communications, *automatically compensates* for the Modbus offset of one. Regard all registers as holding registers where a 30,000 or 40,000 offset can be used (e.g., Current, Phase A = 31,003 or 41,003).

② PM-650 only.

Reg. No. ①	Register Name	Units	Range
1232 ②	Minimum True Power Factor, Phase B	In 1000ths	-100 to +1000 to +100
1233 ②	Minimum True Power Factor, Phase C	In 1000ths	-100 to +1000 to +100
1234 ②	Minimum True Power Factor, Total	In 1000ths	-100 to +1000 to +100
1235 ②	Reserved		
1236 ②	Reserved		
1237 ②	Reserved		
1238 ②	Reserved		
1239 ②	Minimum Real Power, Phase A	kW/ Scale Factor E	0 to ±32,767
1240 ②	Minimum Real Power, Phase B	kW/ Scale Factor E	0 to ±32,767
1241 ②	Minimum Real Power, Phase C	kW/ Scale Factor E	0 to ±32,767
1242 ②	Minimum Real Power, Total	kW/ Scale Factor E	0 to ±32,767
1243 ②	Minimum Reactive Power, Phase A	kVAr/Scale Factor E	0 to ±32,767
1244 ②	Minimum Reactive Power, Phase B	kVAr/Scale Factor E	0 to ±32,767
1245 ②	Minimum Reactive Power, Phase C	kVAr/Scale Factor E	0 to ±32,767
1246 ②	Minimum Reactive Power, Total	kVAr/Scale Factor E	0 to ±32,767

① These registers can be used with POWERLOGIC, Modbus, or Jbus protocols. Although POWERLOGIC and Jbus protocols use a zero-based register addressing convention and Modbus uses a one-based register addressing convention, the power meter, when configured for Modbus communications, *automatically compensates* for the Modbus offset of one. Regard all registers as holding registers where a 30,000 or 40,000 offset can be used (e.g., Current, Phase A = 31,003 or 41,003).

② PM-650 only.

Reg. No. ①	Register Name	Units	Range
1247 ②	Minimum Apparent Power, Phase A	kVA/Scale Factor E	0 to $\pm 32,767$
1248 ②	Minimum Apparent Power, Phase B	kVA/Scale Factor E	0 to $\pm 32,767$
1249 ②	Minimum Apparent Power, Phase C	kVA/Scale Factor E	0 to $\pm 32,767$
1250 ②	Minimum Apparent Power, Total	kVA/Scale Factor E	0 to $\pm 32,767$
1251 ②	Minimum THD/thd Current, Phase A	Percent in 10ths	0 to 10,000
1252 ②	Minimum THD/thd Current, Phase B	Percent in 10ths	0 to 10,000
1253 ②	Minimum THD/thd Current, Phase C	Percent in 10ths	0 to 10,000
1254 ②	Reserved		
1255 ②	Minimum THD/thd Voltage, Phase A	Percent in 10ths	0 to 10,000
1256 ②	Minimum THD/thd Voltage, Phase B	Percent in 10ths	0 to 10,000
1257 ②	Minimum THD/thd Voltage, Phase C	Percent in 10ths	0 to 10,000
1258 ②	Reserved		
1259 ②	Reserved		
1400 ②	Maximum Update Interval	In 1000ths of a second	0 to 10,000
1401 ②	Maximum Frequency	Hertz/Scale Factor F	4500 to 6600
1402 ②	Reserved		
1403 ②	Maximum Current, Phase A	Amps/Scale Factor A	0 to 32,767
1404 ②	Maximum Current, Phase B	Amps/Scale Factor A	0 to 32,767
1405 ②	Maximum Current, Phase C	Amps/Scale Factor A	0 to 32,767
1406 ②	Maximum Current Neutral, Calculated	Amps/Scale Factor A	0 to 32,767
1407 ②	Reserved		
1408 ②	Reserved		
1409 ②	Reserved		
1410 ②	Maximum Current Unbalance, Ph. A	Percent in 10ths	0 to ± 1000
1411 ②	Maximum Current Unbalance, Ph. B	Percent in 10ths	0 to ± 1000

① These registers can be used with POWERLOGIC, Modbus, or Jbus protocols. Although POWERLOGIC and Jbus protocols use a zero-based register addressing convention and Modbus uses a one-based register addressing convention, the power meter, when configured for Modbus communications, *automatically compensates* for the Modbus offset of one. Regard all registers as holding registers where a 30,000 or 40,000 offset can be used (e.g., Current, Phase A = 31,003 or 41,003).

② PM-650 only.

Reg. No. ①	Register Name	Units	Range
1412 ②	Maximum Current Unbalance, Ph. C	Percent in 10ths	0 to ±1000
1413 ②	Maximum Current Unbalance, Worst	Percent in 10ths	0 to ±1000
1414 ②	Maximum Voltage, Phase A-B	Volts/Scale Factor D	0 to 32,767
1415 ②	Maximum Voltage, Phase B-C	Volts/Scale Factor D	0 to 32,767
1416 ②	Maximum Voltage, Phase C-A	Volts/Scale Factor D	0 to 32,767
1417 ②	Reserved		
1418 ②	Maximum Voltage, Phase A	Volts/Scale Factor D	0 to 32,767
1419 ②	Maximum Voltage, Phase B	Volts/Scale Factor D	0 to 32,767
1420 ②	Maximum Voltage, Phase C	Volts/Scale Factor D	0 to 32,767
1421 ②	Reserved		
1422 ②	Maximum Volt. Unbalance, Ph. A-B	Percent in 10ths	0 to ±1000
1423 ②	Maximum Volt. Unbalance, Ph. B-C	Percent in 10ths	0 to ±1000
1424 ②	Maximum Volt. Unbalance, Ph. C-A	Percent in 10ths	0 to ±1000
1425 ②	Maximum Volt. Unbalance, Worst L-L	Percent in 10ths	0 to ±1000
1426 ②	Maximum Volt. Unbalance, Ph. A	Percent in 10ths	0 to ±1000
1427 ②	Maximum Volt. Unbalance, Phase B	Percent in 10ths	0 to ±1000
1428 ②	Maximum Volt. Unbalance, Phase C	Percent in 10ths	0 to ±1000
1429 ②	Maximum Volt. Unbalance, Worst L-N	Percent in 10ths	0 to ±1000
1430 ②	Reserved		
1431 ②	Maximum True Power Factor, Ph. A	In 1000ths	-100 to +1000 to +100
1432 ②	Maximum True Power Factor, Ph. B	In 1000ths	-100 to +1000 to +100
1433 ②	Maximum True Power Factor, Ph. C	In 1000ths	-100 to +1000 to +100
1434 ②	Maximum True Power Factor, Total	In 1000ths	-100 to +1000 to +100
1435 ②	Reserved		
1436 ②	Reserved		

① These registers can be used with POWERLOGIC, Modbus, or Jbus protocols. Although POWERLOGIC and Jbus protocols use a zero-based register addressing convention and Modbus uses a one-based register addressing convention, the power meter, when configured for Modbus communications, *automatically compensates* for the Modbus offset of one. Regard all registers as holding registers where a 30,000 or 40,000 offset can be used (e.g., Current, Phase A = 31,003 or 41,003).

② PM-650 only.

Reg. No. ①	Register Name	Units	Range
1437 ②	Reserved		
1438 ②	Reserved		
1439 ②	Maximum Real Power, Phase A	kW/Scale Factor E	0 to ±32,767
1440 ②	Maximum Real Power, Phase B	kW/Scale Factor E	0 to ±32,767
1441 ②	Maximum Real Power, Phase C	kW/Scale Factor E	0 to ±32,767
1442 ②	Maximum Real Power, Total	kW/Scale Factor E	0 to ±32,767
1443 ②	Maximum Reactive Power, Phase A	kVAr/Scale Factor E	0 to ±32,767
1444 ②	Maximum Reactive Power, Phase B	kVAr/Scale Factor E	0 to ±32,767
1445 ②	Maximum Reactive Power, Phase C	kVAr/Scale Factor E	0 to ±32,767
1446 ②	Maximum Reactive Power, Total	kVAr/Scale Factor E	0 to ±32,767
1447 ②	Maximum Apparent Power, Phase A	kVA/Scale Factor E	0 to ±32,767
1448 ②	Maximum Apparent Power, Phase B	kVA/Scale Factor E	0 to ±32,767
1449 ②	Maximum Apparent Power, Phase C	kVA/Scale Factor E	0 to ±32,767
1450 ②	Maximum Apparent Power, Total	kVA/Scale Factor E	0 to ±32,767
1451 ②	Maximum THD/thd Current, Phase A	Percent in 10ths	0 to 10,000
1452 ②	Maximum THD/thd Current, Phase B	Percent in 10ths	0 to 10,000
1453 ②	Maximum THD/thd Current, Phase C	Percent in 10ths	0 to 10,000
1454 ②	Reserved		
1455 ②	Maximum THD/thd Voltage, Phase A	Percent in 10ths	0 to 10,000
1456 ②	Maximum THD/thd Voltage, Phase B	Percent in 10ths	0 to 10,000
1457 ②	Maximum THD/thd Voltage, Phase C	Percent in 10ths	0 to 10,000
1458 ②	Reserved		
1459 ②	Reserved		
1600– 1616	Unused		

① These registers can be used with POWERLOGIC, Modbus, or Jbus protocols. Although POWERLOGIC and Jbus protocols use a zero-based register addressing convention and Modbus uses a one-based register addressing convention, the power meter, when configured for Modbus communications, *automatically compensates* for the Modbus offset of one. Regard all registers as holding registers where a 30,000 or 40,000 offset can be used (e.g., Current, Phase A = 31,003 or 41,003).

② PM-650 only.

Reg. No. ①	Register Name	Units	Range
ENERGY VALUES ②			
Accumulated Energy			
1617– 1620	Apparent Energy 3-Phase Total	VAH	0 to 9,999,999,999,999,999
1621– 1624	Real Energy 3-Phase Total	WH	0 to +/-9,999,999,999,999,999
1625– 1628	Reactive Energy 3-Phase Total	VArH	0 to +/-9,999,999,999,999,999
1629– 1663	Unused		
DEMAND VALUES ③			
Current Demand			
1700	Unused		
1701	Present Current Demand Phase A	Amps/Scale Factor A	0 to 32,767
1702	Present Current Demand Phase B	Amps/Scale Factor A	0 to 32,767
1703	Present Current Demand Phase C	Amps/Scale Factor A	0 to 32,767
1704	Present Demand Neutral Current	Amps/Scale Factor A	0 to 32,767
1705– 1708	Unused		
1709	Peak Current Demand Phase A	Amps/Scale Factor A	0 to 32,767
1710	Peak Current Demand Phase B	Amps/Scale Factor A	0 to 32,767
1711	Peak Current Demand Phase C	Amps/Scale Factor A	0 to 32,767
1712	Peak Current Neutral Current	Amps/Scale Factor A	0 to 32,767
1730	Unused		

① These registers can be used with POWERLOGIC, Modbus, or Jbus protocols. Although POWERLOGIC and Jbus protocols use a zero-based register addressing convention and Modbus uses a one-based register addressing convention, the power meter, when configured for Modbus communications, *automatically compensates* for the Modbus offset of one. Regard all registers as holding registers where a 30,000 or 40,000 offset can be used (e.g., Current, Phase A = 31,003 or 41,003).

② Each energy is kept in 4 registers, modulo 10,000 per register.

③ Demand Values available in PM-620 and PM-650 only.

Reg. No. ①	Register Name	Units	Range
Power Demand ②			
1731	Present Real Power Demand, 3-Phase Total	kW/Scale Factor E	0 to +/-32,767
1732	Present Reactive Power Demand, 3-Phase Total	kVAr/Scale Factor E	0 to +/-32,767
1733	Present Apparent Power Demand 3-Phase Total	kVA/Scale Factor E	0 to 32,767
1734	Peak Real Power Demand, 3-Phase Total	kW/Scale Factor E	0 to +/-32,767
1735	Average Power Factor, @ Peak Real	Percent in 1000ths	-100 to +1000 to +100
1736– 1737	Unused		
1738	Peak Reactive Power Demand 3-Phase Total	kVar/Scale Factor E	0 to +/-32,767
1739	Average Power Factor @ Peak Reactive	Percent in 1000ths	-100 to +1000 to +100
1740– 1741	Unused		
1742	Peak Apparent Power Demand, 3-Phase Total	kVA/Scale Factor E	0 to 32,767
1743	Average Power Factor @ Peak Apparent	Percent in 1000ths	-100 to +1000 to +100
1744	Unused		
1745	Unused		

① These registers can be used with POWERLOGIC, Modbus, or Jbus protocols. Although POWERLOGIC and Jbus protocols use a zero-based register addressing convention and Modbus uses a one-based register addressing convention, the power meter, when configured for Modbus communications, *automatically compensates* for the Modbus offset of one. Regard all registers as holding registers where a 30,000 or 40,000 offset can be used (e.g., Current, Phase A = 31,003 or 41,003).

② Reactive Demand may be calculated either using the fundamental only (default) or using total harmonics, user selectable.

Reg. No. ①	Register Name	Units	Range
1746 ②	Predicted Real Power Demand, 3-Phase Total	kW/Scale Factor E	0 to +/- 32,767
1747 ②	Predicted Reactive Power Demand, 3-Phase Total	kVAr/Scale Factor E	0 to 32,767
1748 ②	Predicted Apparent Power Demand, 3-Phase Total	kVA/Scale Factor E	0 to 32,767
1749	Unused		
1750	Unused		
1751	Unused		
1752	Unused		

Reg. No. ①	Register Name	Units	Range
------------	---------------	-------	-------

DATE/TIME COMPRESSED FORM (3 Registers) ③

*The date and time in registers 1800–1802 are stored as follows. Other dates and times (through register 1877) are stored in an identical manner. Set date/time by writing to registers 1842–1844.

Register 1800, Month (byte 1) = 1–12, Day (byte 2) = 1–31

Register 1801, Year (byte 1) = 0–199, Hour (byte 2) = 0–23,

Register 1802, Minutes (byte 1) = 0–59, Seconds (byte 2) = 0–59. The year is zero based on the year 1900 in anticipation of the 21st century, (e.g., 1989 would be represented as 89 and 2009 would be represented as 109).

1800– 1802	Last Restart Date/Time	Month, Day, Yr, Hr, Min, Sec	*See note above
1803– 1805	Date/Time Demand of Peak Current Phase A	Month, Day, Yr, Hr, Min, Sec	Same as Registers 1800–1802
1806– 1808	Date/Time Demand of Peak Current Phase B	Month, Day, Yr, Hr, Min, Sec	Same as Registers 1800–1802
1809– 1811	Date/Time Demand of Peak Current Phase C	Month, Day, Yr, Hr, Min, Sec	Same as Registers 1800–1802
1812– 1814	Date/Time of Peak Demand (Average Real Power)	Month, Day, Yr, Hr, Min, Sec	Same as Registers 1800–1802

① These registers can be used with POWERLOGIC, Modbus, or Jbus protocols. Although POWERLOGIC and Jbus protocols use a zero-based register addressing convention and Modbus uses a one-based register addressing convention, the power meter, when configured for Modbus communications, *automatically compensates* for the Modbus offset of one. Regard all registers as holding registers where a 30,000 or 40,000 offset can be used (e.g., Current, Phase A = 31,003 or 41,003).

② PM-650 only.

③ PM-620 and PM-650 only.

Reg. No. ①	Register Name	Units	Range
1815– 1817	Date/Time of Last Reset of Peak Demand Current	Month, Day, Yr, Hr, Min, Sec	Same as Registers 1800–1802
1818– 1820 ②	Date/Time of Last Reset of Min/Max Values	Month, Day, Yr, Hr, Min, Sec	Same as Registers 1800–1802
1824– 1826	Date/Time when Peak Power Demands Were Last Cleared	Month, Day, Yr, Hr, Min, Sec	Same as Registers 1800–1802
1827– 1829	Date/Time when Accumulated Energy Last Cleared	Month, Day, Yr, Hr, Min, Sec	Same as Registers 1800–1802
1830– 1832	Date/Time when Control Power Failed Last	Month, Day, Yr, Hr, Min, Sec	Same as Registers 1800–1802
1833– 1841	Unused		
1842– 1844	Present/Set Date/Time	Month, Day, Yr, Hr, Min, Sec	Same as Registers 1800–1802
1845– 1847	Calibration	Month, Day, Yr, Hr, Min, Sec	Same as Registers 1800–1802
1848– 1856	Unused		
1857– 1859	Date/Time of Peak Reactive Demand (Reactive Power)	Month, Day, Yr, Hr, Min, Sec	Same as Registers 1800–1802
1860– 1862	Date/Time of Peak Apparent Demand Power	Month, Day, Yr, Hr, Min, Sec	Same as Registers 1800–1802
1863– 1874	Unused		
1875– 1877	Date/Time of Peak Demand Neutral Current	Month, Day, Yr, Hr, Min, Sec	Same as Registers 1800–1802

① These registers can be used with POWERLOGIC, Modbus, or Jbus protocols. Although POWERLOGIC and Jbus protocols use a zero-based register addressing convention and Modbus uses a one-based register addressing convention, the power meter, when configured for Modbus communications, *automatically compensates* for the Modbus offset of one. Regard all registers as holding registers where a 30,000 or 40,000 offset can be used (e.g., Current, Phase A = 31,003 or 41,003).

② PM-650 only.

Reg. No. ①	Register Name	Units	Range	Description
CONFIGURATION (Read Only Registers)				
2000	Unused			
2001	System Conn.	None	30, 31, 40	
2002	CT Ratio 3-Phase Primary Ratio Term	None	1 to 32,767	
2003	CT Ratio 3-Phase Secondary Ratio Term	None	1 or 5	
2004– 2005	Unused			
2006	PT Ratio 3-Phase Primary Ratio Term	None/ Scale Factor	1 to 32,767	
2007	PT Ratio 3-Phase Primary Scale Factor	None	0 to 2	
2008	PT Ratio 3-Phase Secondary Ratio Term	None	100, 115, 120 (120 default)	
2009	Phase A Current Correction Factors	10,000ths	5,000–20,000	
2010	Phase B Current Correction Factors	10,000ths	5,000–20,000	
2011	Phase C Current Correction Factors	10,000ths	5,000–20,000	
2012	Unused			
2013	Phase A Voltage Correction Factors	10,000ths	5,000–20,000	
2014	Phase B Voltage Correction Factors	10,000ths	5,000–20,000	
2015	Phase C Voltage Correction Factors	10,000ths	5,000–20,000	
2016	Nominal System Frequency	—	50, 60	
2017	Device Address	None	0 to 199 1 to 247 1 to 255	SY/Max Device Address Modbus Device Address Jbus Device Address

① These registers can be used with POWERLOGIC, Modbus, or Jbus protocols. Although POWERLOGIC and Jbus protocols use a zero-based register addressing convention and Modbus uses a one-based register addressing convention, the power meter, when configured for Modbus communications, *automatically compensates* for the Modbus offset of one. Regard all registers as holding registers where a 30,000 or 40,000 offset can be used (e.g., Current, Phase A = 31,003 or 41,003).

Reg. No. ①	Register Name	Units	Range	Description
2018	Device Baud Rate	Baud	1200, 2400, 4800, 9600, 19,200	
2019	Phase Adjust User Correction	In 100ths	±1000	
2020	Scale Group A: Ammeter Per Phase	None	-2 to 0	Scale Group A: Ammeter Per -2=scale by 0.01 -1=scale by 0.10 0=scale by 1.00 (default)
2023	Scale Group D: Voltmeter	None	-1 to 2	Scale Group D: Voltmeter -1=scale by 0.10 0=scale by 1.00 (default) 1=scale by 10.0 2=scale by 100
2024	Scale Group E: kWattmeter, kVarmeter, kVA	None	-3 to 3	Scale Group E: kWattmeter, kVarmeter, kVA -3=scale by 0.001 -2=scale by 0.01 -1=scale by 0.1 0=scale by 1.0 (default) 1=scale by 10 2=scale by 100 3=scale by 1000
2026	Scaling Error	None	1 to 1F	Possible Scaling Error Bit 0 set if any other bits are set Bit 1 is set for possible phase current scale error Bit 2 unused Bit 3 is set for possible phase voltage scale error Bit 4 is set for possible power scale error
2027	Unused			
2028	Command Password	None	0 to +/-32,767	Command Password (Computed by Power Meter)
2029	Master Password	None	0 to 9998	Full Access Reset & Setup Password

① These registers can be used with POWERLOGIC, Modbus, or Jbus protocols. Although POWERLOGIC and Jbus protocols use a zero-based register addressing convention and Modbus uses a one-based register addressing convention, the power meter, when configured for Modbus communications, *automatically compensates* for the Modbus offset of one. Regard all registers as holding registers where a 30,000 or 40,000 offset can be used (e.g., Current, Phase A = 31,003 or 41,003).

Reg. No. ①	Register Name	Units	Range	Description
2030	Unused			
2031	Reset Access Password	None	0 to 9998	Reset Only Password
2032	Limited Access Disable Bit Mask	None	0 to F (Hex)	Limited Display Reset Disable Bit Mask A 1=Disable Bit 0=Disable Demand Amps Reset Capability Bit 1=Disable Demand Power Reset Capability Bit 2=Disable Energy Reset Capability
2040– 2041	Power Meter Label	None	Any Valid Alpha-Numeric	
2042– 2049	Power Meter Nameplate	None	Any Valid Alpha-Numeric	
2077	Power Demand	Minutes	1–60 min @ 1 min. Multiples	
2078 ②	Power Demand Sub-Interval	Minutes	1-60 min @ 1 min. multiples	

① These registers can be used with POWERLOGIC, Modbus, or Jbus protocols. Although POWERLOGIC and Jbus protocols use a zero-based register addressing convention and Modbus uses a one-based register addressing convention, the power meter, when configured for Modbus communications, *automatically compensates* for the Modbus offset of one. Regard all registers as holding registers where a 30,000 or 40,000 offset can be used (e.g., Current, Phase A = 31,003 or 41,003).

② PM-650 only.

Reg. No. ①	Register Name	Units	Range	Description
2081	Operating Mode Selections Bitmap	None	0 to FFFF	Power Meter Operating Mode Selections Bitmap Bit 0 indicates VAr sign convention ② 0=CM 1 convention (default) 1=alternate convention Bit 1 indicates Reactive Energy and Demand calculation ② 0=fundamental only (default) 1=include harmonic cross products (displacement & distortion) Bit 2 is unused Bit 3 is unused Bit 4 indicates whether display setup is enabled ② 0=display setup enabled (default) 1=indicates display setup is disabled Bit 5 is unused Bit 6 indicates parity selection 0 =Even 1=None Bit 7 indicates protocol selection 0=POWERLOGIC (default) 1=Modbus/Jbus Bit 8 is unused Bit 9 is unused Bit 10 is unused Bit 11 is unused Bit 12 0=THD (default) 1=thd All other bits are unused
2082	Energy Accumulation Method	None	0–3	Energy Accumulation Method ② 0=Absolute 1=Signed 2=In only 3=Out only
2085	Square D Product ID Number	None	0 to 3000	481=model 600 power meter 482=model 620 power meter 483=model 650 power meter
2091	PMOS-M Revision Level	None	0 to 32,767	
2092	PMOS-D Revision Level	None	0 to 32,767	
2093	PMRS Revision Level	None	0 to 32,767	
2094	Reserved for DL			

① These registers can be used with POWERLOGIC, Modbus, or Jbus protocols. Although POWERLOGIC and Jbus protocols use a zero-based register addressing convention and Modbus uses a one-based register addressing convention, the power meter, when configured for Modbus communications, automatically compensates for the Modbus offset of one. Regard all registers as holding registers where a 30,000 or 40,000 offset can be used (e.g., Current, Phase A = 31,003 or 41,003).

② SMS-3000 or SMS-1500 necessary to select alternate.

Reg. No. ①	Register Name	Units	Range
Alarm Configuration ②			
5780	Event Counter 1	None	0–32,767
5781	Event Counter 2	None	0–32,767
5782	Event Counter 3	None	0–32,767
5783	Event Counter 4	None	0–32,767
5784	Reserved		
5785	Event Counter 6	None	0–32,767
5786	Event Counter 7	None	0–32,767
5787	Event Counter 8	None	0–32,767
5788	Event Counter 9	None	0–32,767
5789	Event Counter 10	None	0–32,767
5790	Event Counter 11	None	0–32,767
5791	Reserved		
5792	Event Counter 13	None	0–32,767
5793	Event Counter 14	None	0–32,767
5794	Event Counter 15	None	0–32,767
5795	Event Counter 16	None	0–32,767
5796	Event Counter 17	None	0–32,767
5797	Event Counter 18	None	0–32,767
5798	Event Counter 19	None	0–32,767
5799	Event Counter 20	None	0–32,767
5800	Event Counter 21	None	0–32,767
5801	Event Counter 22	None	0–32,767
5802	Event Counter 23	None	0–32,767

① These registers can be used with POWERLOGIC, Modbus, or Jbus protocols. Although POWERLOGIC and Jbus protocols use a zero-based register addressing convention and Modbus uses a one-based register addressing convention, the power meter, when configured for Modbus communications, *automatically compensates* for the Modbus offset of one. Regard all registers as holding registers where a 30,000 or 40,000 offset can be used (e.g., Current, Phase A = 31,003 or 41,003).

② PM-650 only.

Reg. No. ①	Register Name	Units	Range
5803	Event Counter 24	None	0–32,767
5804	Event Counter 25	None	0–32,767
5805	Event Counter 26	None	0–32,767
5806	Event Counter 27	None	0–32,767
5807	Event Counter 28	None	0–32,767
5808	Event Counter 29	None	0–32,767
5809	Event Counter 30	None	0–32,767
5810- 5819	Reserved		
5820	Event Counter 41	None	0–32,767
5821	Event Counter 42	None	0–32,767

APPENDIX G—MODBUS AND JBUS FUNCTIONS SUPPORTED

Standard Modbus and Jbus functions supported by the power meter are listed below.

- 3 Read Registers
- 4 Read Registers
- 6 Write Single Register
- 8 Diagnostic Codes:
 - 10 Clear Counters and Diagnostic Registers
 - 11 Returns the number of messages received with correct CRC.
 - 12 Returns the number of messages received with CRC error.
 - 13 Returns the number of exception replies sent.
 - 14 Returns the number of messages sent to this unit.
 - 15 Returns the number of broadcast messages received.
 - 16 Returns slave NAK count.
 - 17 Returns slave busy count.
 - 18 Returns the number of characters received with error.
- 11 Fetch Communications Event Counter
- 16 Write multiple registers
- 17 Report slave identification number (modified; see explanation on next page)
- 22 Single register write with mask
- 23 Block register read/write

Function 17 (11 Hex)—Report Slave ID

This returns a description of the device present at the slave address. Because POWERLOGIC device IDs consist of two bytes, the slave ID for any POWERLOGIC device will be 100 (64 hex), and the device ID or address will be returned as Additional Data Hi and Lo.

Query

<u>Description</u>	<u>Example (Hex)</u>
Slave Address	11
Function Code	11
CRC Lo	—
CRC Hi	—

Response

<u>Description</u>	<u>Example (Hex)</u>
Slave Address	11
Function Code	11
Byte Count	04
Slave ID	64 ①
Run Indicator Status	FF
Additional Data Hi	01
Additional Data Lo	E1
CRC Lo	—
CRC Hi	—

① For the power meter, this will always be 64. See Additional Data Hi/Lo for POWERLOGIC address.

APPENDIX H—2-WIRE MODBUS OR JBUS

COMMUNICATIONS WIRING

When wiring the communications terminals for 2-wire Modbus or Jbus, be sure to jumper IN+ to OUT+ and IN- to OUT- (figure H-1).

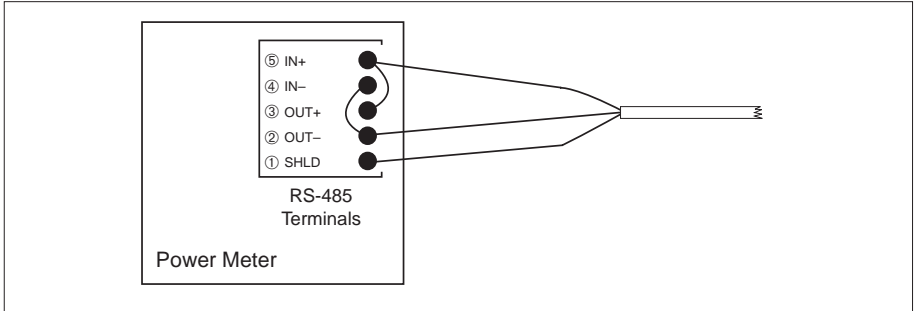

Figure H-1: 2-wire Modbus or Jbus wiring

The table below shows the maximum distance that a daisychain of power meters communicating via 2-wire Modbus or Jbus can extend. Baud rate and the number of devices on the daisychain are considerations in calculating the maximum distance.

Table H-1
Maximum Distances of 2-Wire Modbus or Jbus
Comms Link at Different Baud Rates

Baud Rate	Maximum Distances	
	1–8 Devices	9–16 Devices
1200	10,000 ft. (3,048 m)	10,000 ft. (3,048 m)
2400	10,000 ft. (3,048 m)	5,000 ft. (1,524 m)
4800	10,000 ft. (3,048 m)	5,000 ft. (1,524 m)
9600	10,000 ft. (3,048 m)	4,000 ft. (1,219 m)
19200	5,080 ft. (1,548 m)	2,500 ft. (762 m)

APPENDIX I—ALARM SETUP (PM-650 ONLY)

INTRODUCTION

The power meter is designed to handle a wide range of metering requirements. To handle very large and very small metering values, the power meter uses scale factors to act as multipliers. These scale factors range from 0.001 up to 1000 and are expressed as powers of 10. For example, $0.001 = 10^{-3}$. These scale factors are necessary because the power meter stores data in registers which are limited to integer values between $-32,767$ and $+32,767$. When a value is either larger than $32,767$, or is a non-integer, it is expressed as an integer in the range of $\pm 32,767$ associated with a multiplier in the range of 10^{-3} to 10^3 .

When POWERLOGIC application software is used to set up alarms, it automatically scales pickup and dropout setpoints.

However, when alarm setup is performed from the power meter's display, you must:

- determine how the corresponding metering value is scaled, and
- take the scale factor into account when entering alarm pickup and dropout settings

SCALING ALARM SETPOINTS

If you do not have POWERLOGIC software, you must set up alarms from the power meter display. This section explains how to properly scale alarm setpoints so you can do that.

The power meter displays the scale factor needed for the pickup and dropout setpoints in the Alarm Setup mode. Only the pickup and dropout values require scale factors. The pickup and dropout delays are entered in seconds.

After enabling an alarm, the next screen displayed is the scale factor for the alarm pickup value. For example, when setting up an Under Frequency alarm, the screen displays "Enter PU value in FREQUENCY $\times 100$." This means that if you want to set a pickup value of 58 HZ, you must enter the pickup value as 5800. After you enter the pickup value and pickup delay, the next screen displays the proper scaling of the dropout value. Enter the dropout value in the same manner as the pickup value.

As another example, consider an Under Voltage Alarm. For a 480 V system, you might want to enter the pickup value as 455 V. The screen may display "Enter PU value in VOLTS $\times 1$." Therefore, you can enter the pickup value as just 455 since the scale factor is 1.

As one more example, consider an Unbalance Alarm. The power meter prompts you to enter the pickup and dropout values as PERCENT \times 10. Therefore, to alarm on an unbalance of 3.5%, enter 35 as the pickup value.

ALARM CONDITIONS AND ALARM NUMBERS

The power meter's predefined alarm conditions are listed below along with the information given for each alarm condition.

Alarm No.	A code number used to refer to individual alarms.
Alarm Description	A brief description of the alarm condition.
Test Register	The register number that contains the value (where applicable) that is used as the basis for a comparison to alarm pickup and dropout settings.
Units	The units that apply to the pickup and dropout settings.
Scale Group	The Scale Group that applies to the test register's metering value (A–F). For a description of scale groups, see Scale Group Definitions in this section.
Alarm Type	A reference to a definition providing details on the operation and configuration of the alarm. For a description of alarm types, see Alarm Type Definitions in this section.

Alarm No.	Alarm Description	Test Register	Units	Scale Group	Alarm Type
01	Overcurrent Phase A	1003	Amps	A	A
02	Overcurrent Phase B	1004	Amps	A	A
03	Overcurrent Phase C	1005	Amps	A	A
04	Overcurrent Neutral	1006	Amps	A	A
05	Reserved				
06	Undercurrent Phase A	1003	Amps	A	B
07	Undercurrent Phase B	1004	Amps	A	B
08	Undercurrent Phase C	1005	Amps	A	B
09	Current Unbalance Phase A	1010	Tenths %		A
10	Current Unbalance Phase B	1011	Tenths %		A
11	Current Unbalance Phase C	1012	Tenths %		A
12	Reserved				
13	Overvoltage Phase A	1018	Volts	D	A
14	Overvoltage Phase B	1019	Volts	D	A
15	Overvoltage Phase C	1020	Volts	D	A
16	Overvoltage Phase A-B	1014	Volts	D	A
17	Overvoltage Phase B-C	1015	Volts	D	A
18	Overvoltage Phase C-A	1016	Volts	D	A
19	Undervoltage Phase A	1018	Volts	D	B
20	Undervoltage Phase B	1018	Volts	D	B
21	Undervoltage Phase C	1018	Volts	D	B
22	Undervoltage Phase A-B	1014	Volts	D	B
23	Undervoltage Phase B-C	1015	Volts	D	B
24	Undervoltage Phase C-A	1016	Volts	D	B
25	Voltage Unbalance Phase A	1026	Tenths %		A
26	Voltage Unbalance Phase B	1027	Tenths %		A
27	Voltage Unbalance Phase C	1028	Tenths %		A
28	Voltage Unbalance Phase A-B	1022	Tenths %		A
29	Voltage Unbalance Phase B-C	1023	Tenths %		A
30	Voltage Unbalance Phase C-A	1024	Tenths %		A
31-40	Reserved				
41	Overfrequency	1001	Hundredths of Hz	F	A
42	Underfrequency	1001	Hundredths of Hz	F	B

Scale Group Definitions

Scale Group A—Phase and Neutral Current

Amps	Scale Factor
0–327.67	–2
0–3276.7	–1
0–32767	0 (default)

Scale Group D—Voltage, L-L, L-N

Amps	Scale Factor
0–3276.7	–1
0–32767	0 (default)
0–327.67	1
0–3276.7	2

Scale Group E—Power kW, kVAr, kVA

Power	Scale Factor
0–32.767 kW, kVAr, kVA	–3
0–327.67 kW, kVAr, kVA	–2
0–3276.7 kW, kVAr, kVA	–1
0–32767 kW, kVAr, kVA	0 (default)
0–327.67 MW, MVA, MVA	1
0–3276.7 MW, MVA, MVA	2
0–32767 MW, MVA, MVA	3

Scale Group F—Frequency

Hertz	Scale Factor
45.00–66.00	–2

Alarm Type Definitions

Alarm Type	Alarm Description	Alarm Operation
A	Overvalue Alarm	If the test register value exceeds the setpoint long enough to satisfy the pickup delay period, the alarm condition will be true. When the value in the test register falls below the dropout setpoint long enough to satisfy the dropout delay period, the alarm will drop out. Pickup and dropout setpoints are positive. Delays are in seconds.
B	Undervalue Alarm	If the test register value is below the setpoint long enough to satisfy the pickup delay period, the alarm condition will be true. When the value in the test register rises above the dropout setpoint long enough to satisfy the dropout delay period, the alarm will drop out. Pickup and dropout setpoints are positive. Delays are in seconds.

APPENDIX J—CALCULATING LOG FILE SIZE (PM-650 ONLY)

The PM-650 has 1K of memory available for the event log and data log combined. Using POWERLOGIC software, you can configure the sizes of the event log and data log within the available memory.

Data is stored in 16-bit registers (16 bits=2 bytes). Since there are 1024 bytes in 1K of memory, there are 512 registers ($1024/2$) dedicated to logging in the power meter. Sixteen registers are used by the power meter for memory management; therefore, 496 registers are available for data logging.

Some quantities that you can log require more registers than others. Cumulative energy readings require 4 registers and non-energy meter readings require 1 register. Additional registers are required to log the date and time for each entry. Therefore, the number and type of values you store, and how often you store those values, affect the rate at which the data logging memory fills up. Each event log entry uses 8 registers of memory.

This appendix tells how to calculate the approximate size of the log file using the above information. To see if the log file you've set up will fit in the available logging memory, calculate the size of the log file using the worksheet below. Your total should not exceed 496 registers.

To calculate the size of the log file, follow these steps:

1. Multiply the number of cumulative energy readings by 4 (registers): 1. _____
2. Enter the number of non-energy meter readings: 2. _____
3. Add lines 1 and 2: 3. _____
4. Add 3 to the value on line 3 (for date/time of each entry): 4. _____
5. Multiply line 4 by the maximum number of records in the data log file (how many times you are logging each quantity): 5. _____
6. Multiply the number of events by 8. 6. _____
7. Add lines 5 and 6. 7. _____

Line 7 should not exceed 496.

For example, suppose you want to log cumulative apparent energy every hour for 2 days and store the last 20 events:

1. Multiply the number of cumulative energy readings by 4 (registers): 1. $1 \times 4 = 4$
2. Enter the number of non-energy meter readings: 2. 0
3. Add lines 1 and 2: 3. 4
4. Add 3 to the value on line 3. (For date/time of each entry): 4. 7
5. Multiply line 4 by the maximum number of records in the data log file (how many times you are logging each quantity): 5. $24 \text{ (hours)} \times 2 \text{ (days)} \times 7 = 336$
6. Multiply the number of events by 8: 6. $20 \times 8 = 160$
7. Add lines 5 and 6: 7. $336 + 160 = 496$

This is a valid log because the total does not exceed 496.

In another example, suppose you want to log current and voltage for each phase every 4 hours for one week and store the last 10 events:

1. Multiply the number of cumulative energy readings by 4 (registers): 1. 0
2. Enter the number of non-energy meter readings: 2. 6
3. Add lines 1 and 2: 3. 6
4. Add 3 to the value on line 3. (For date/time of each entry): 4. 9
5. Multiply line 4 by the maximum number of records in the data log file (how many times you are logging each quantity): 5. $9 \times 6 \text{ (per day)} \times 7 \text{ (days)} = 378$
6. Multiply the number of events by 8: 6. $10 \times 8 = 80$
7. Add lines 5 and 6: 7. $378 + 80 = 458$

This is also a valid log.

Index

A

- Alarm setup
 - alarm conditions and numbers 105
 - alarm type definitions 107
 - scale group definitions 107
 - scaling alarm setpoints 104

Alarming

- onboard 66

Alarms

- setpoint-driven 66
- setting up onboard 55
- viewing active 56

B

- Baud rate, maximum distances per
 - 2-Wire Modbus or Jbus 103
 - POWERLOGIC, Modbus, Jbus 41
- Block interval demand with subinterval option 64

Buttons 51

C

- CAB-102 73
- CAB-104 73
- CAB-107 73
 - labeling leads 43
- CAB-108 73
- Cable pinouts 73
- Cables, assembling custom length 2
- Calculating log file size 108
- Calculating the pulse constant 65
- CC-100 pinouts 73
- Communication cable pinouts 73
- Communications
 - connecting to a PC—illustration
 - via POWERLOGIC communications 36
 - connecting to a personal computer
 - using Modbus or Jbus 40
 - connecting to a PNIM 37
 - connecting to a programmable controller 38
 - link
 - biasing 42
 - link, length of
 - Jbus/2-wire Modbus 103
 - POWERLOGIC, Modbus, or Jbus 41
 - resetting Demand and Energy via 79
 - terminating the communications link 44
 - wiring
 - Jbus/2-wire Modbus 103
 - POWERLOGIC 35

Control power

- deriving from phase voltage inputs 31
- input specifications 71
- terminals—illustration 10

D

- Daisy chaining
 - RS-485 communications terminals—
illustration 42

Daisy chaining PM&CS devices 41

DC control power wiring—illustration 29

Demand

- peak 64
- predicted 64

Demand power calculation method 63

Demand power calculation methods

- block interval demand
 - w/ subinterval option 64
- sliding block interval demand 63
- synch to comms 64

Demand reading (PM-620 only) 63

Diagnostics

- mode 50
- viewing information 55

Dimensions 72

DIN rail

- mounting power meter on 18

Display mode 50

E

- Energy readings 61
- Environmental specifications 71

F

- Factory defaults, setup parameters 52
- Function 17 (11 Hex)—Report slave ID 102

G

Grounding 32

I

Installation

- display 11
- options 11
- power meter 14

J

Jbus protocol 39

K

- KYZ pulse output 65
 - illustration 10
 - wiring 33

L

- Length of the communication link
POWERLOGIC, Modbus, or Jbus 41
- Log file size, calculating 108

M

- MCT-485—illustration 45
- MCTAS-485—illustration 44
- Metering
 - capabilities 57
 - demand power calculation method 63
 - demand readings 63
 - energy readings 61
 - input electrical specifications 70
 - real-time readings 57
 - specifications 70
- Min/max conventions
 - power factor 58
- Min/max values 57
- Modbus and Jbus
 - functions supported 101
- Modbus RTU protocol 39
- Mode
 - accessing a 48
 - button 51
 - diagnostics 50
 - display 50
 - using 55
 - resets 50
 - setup 49
- Modes 47
- Mounting. *See Installation*

O

- Onboard alarming 66–68
- Onboard alarms
 - setting up 55

P

- Password 52, 96
- Peak demand 64
- Phase voltage inputs
 - deriving control power from 31
- Physical specifications 71
- Pinouts. *See Communication Cable Pinouts*
- PM&CS
 - daisy chaining devices 41
 - defined 35
- PNIM 37
- Power Analysis Values
 - THD, thd 62
- Power factor min/max conventions 58

Power Meter

- as first device on PM&CS or Modbus comms link 42
 - connecting to a personal computer 36
 - connecting to a PNIM—illustration 37
 - connections, wiring—illustration 10
 - description 1
 - dimensions 72
 - display
 - dimensions 72
 - display comms port—illustration 9
 - displaying data, procedure for 7, 55
 - how the buttons work 51
 - illustration 8
 - installation 11
 - installing in existing cutout 12
 - installing on panel without existing cutout 13
 - modes 47
 - operation modes 7
 - RS-232 port—illustration 9
 - features 1
 - grounding 32
 - installation 14, 18
 - DIN rail 18
 - directly behind display 14
 - remote mounting 16
 - instrumentation summary 2
 - models compared 2
 - mounting options 11
 - navigating parameters 48
 - setup 52
 - flowchart 53
 - system wiring connections 75
 - wiring 30
 - Predicted demand 64
 - Programmable controller 38
 - Protocols 35
 - Jbus 39
 - Modbus RTU 39
 - POWERLOGIC 35
 - Pulse constant
 - calculating the 65
 - Pulse output, KYZ 65
- ## R
- Real-time readings 57
 - Register list 81–100
 - alarm configuration 99
 - configuration 95
 - date/time compressed form 93
 - demand values
 - current demand 91
 - power demand 92

Register list 81–100 (cont.)
 energy values
 accumulated energy 91
 real time metered values 81
Regulatory/Standards compliance 71
Relay functions
 setpoint-controlled 67
Relay output specifications 71
Resets mode 50
Resets, performing 54
Routing wires—illustration 30
RS-485 comms terminals—ill. 10

S

Safety precautions 5
Setpoint-controlled
 relay functions 67
Setpoint-controlled relay functions
 undervoltage 68
Setpoint-controlled relay functions
 unbalance current 68
 unbalance voltage 68
Setpoint-driven alarms 66
Setting up onboard alarms 55
Setting up the power meter 52
Setup 7
 mode 49
 parameters, factory defaults 52
Sliding block interval demand 63
Solid-state KYZ pulse output 33
Specifications 70
Synch to comms 64
System connections 21
System wiring connections 75

T

Terminal identification 10
Terminating
 communications link 44
 with MCTAS-485—illustration 44
 with terminal block and MCT-485—ill. 45
THD, thd 62

U

Unbalance current 68
Unbalance voltage 68
Undervoltage 68

V

Values
 min/max 57
VAR sign convention
 alternate 60
 changing the 79
 default 59
Viewing active alarms 56

W

Wiring
 240/120 V 1-phase, 3-wire direct voltage
 connection with 2 CTs 76
 2-wire Modbus or Jbus 103
 max. distance of comms link 103
 3-phase, 3-wire delta direct voltage
 connection with 2 CTs 24
 3-phase, 3-wire delta with 2 PTs and
 2 CTs 25
 3-phase, 3-wire delta with 2 PTs and
 3 CTs 26
 3-phase, 4-wire delta with 3 PTs and
 3 CTs 77
 3-ph, 4-w wye, 3-w load with 3 PTs
 and 2 CTs 78
 3-phase, 4-wire wye, ground and direct
 voltage connection, with 3 CTs 27
 3-phase, 4-wire wye ground with 3 PTs and
 3 CTs—ill. 28
 biasing the communications link 42
 communications
 Modbus RTU 39
 Jbus 39
 POWERLOGIC protocol 35
 CTs, PTs, and control power 21
 dc control power 29
 deriving control power from phase voltage
 deriving 31
 Labeling the CAB-107 leads 43
 routing wires 30
 routing wires—illustration 30
 solid-state KYZ pulse output 33
 supported connections 74
 system connections 21, 75
 terminating the communications link 44



SQUARE D



PowerLogic[®]

Power Meter

Class 3020



NOTICE

Read these instructions carefully and look at the equipment to become familiar with the device before trying to install, operate, or maintain it. The following special messages appear throughout this bulletin to warn of potential hazards.



DANGER

Used where there is a hazard of severe bodily injury or death. Failure to follow a "DANGER" instruction **will** result in death or **severe** bodily injury.



WARNING

Used where there is a hazard of bodily injury or death. Failure to follow a "WARNING" instruction can result in death or bodily injury.



CAUTION

Used where there is a hazard of equipment damage. Failure to follow a "CAUTION" instruction can result in damage to equipment.

FCC NOTICE: This equipment complies with the requirements in Part 15 of FCC rules for a Class A computing device. Operation of this equipment in a residential area may cause unacceptable interference to radio and TV reception, requiring the operator to take whatever steps are necessary to correct the interference.

PLEASE NOTE: Electrical equipment should be serviced only by qualified electrical maintenance personnel, and this document should not be viewed as sufficient for those who are not otherwise qualified to operate, service, or maintain the equipment discussed. Although reasonable care has been taken to provide accurate and authoritative information in this document, no responsibility is assumed by Square D for any consequences arising out of the use of this material.

TECHNICAL SUPPORT

For technical support, contact the

Power Monitoring and Control Systems Technical Support Center.

Hours are 7:30 A.M. to 4:30 P.M., Central Time, Monday through Friday.

www.powerlogic.com

BBS: (615) 287-3414

Fax: (615) 287-3404

Phone: (615) 287-3400

POWERLOGIC, POWERLINK, Square D, and  are Registered Trademarks of Square D Company. System Manager is a trademark of Square D.

Other names are trademarks or service marks of their respective companies.

© 1998 Square D. All rights reserved. This bulletin may not be copied in whole or in part, or transferred to any other media without the written permission of Square D Company.

Registration Card

Register your POWERLOGIC Power Meter today and get:

- Free expert technical phone support—just call (615) 287-3400
- Advance notice on product upgrades and new product releases
- Advance notice on special product offers and price discounts

Name _____ Dept./Title _____

Company _____

Address _____

City _____

State _____ Country _____ Zip/Postal Code _____

Telephone _____ Fax _____

Product Purchased Through (Distributor) _____



NO POSTAGE
NECESSARY
IF MAILED
IN THE
UNITED STATES

BUSINESS REPLY MAIL

FIRST CLASS MAIL PERMIT NO. 635 PALATINE, IL

POSTAGE WILL BE PAID BY ADDRESSEE



PowerLogic[®]

SQUARE D COMPANY
ATTN CUSTOMER SERVICE
295 TECH PARK DRIVE
SUITE 100
LAVERGNE, TN 37086



Contents

Chapter 1—Introduction	1
What is the Power Meter?	1
Using This Bulletin	3
Notational Conventions	3
Not Covered in this Bulletin	3
Chapter 2—Safety Precautions	5
Chapter 3—Hardware Description	7
Display	7
Power Meter Connections	10
Chapter 4—Installation	11
Power Meter/Display Mounting Options	11
Mounting the Display	12
In Existing 1% Ammeter/Voltmeter Cutout	12
On Panel Without Existing 1% Ammeter/Voltmeter Cutout	13
Mounting the Power Meter	14
Directly Behind the Display	14
Remote Mounting	16
DIN Rail Mounting	18
Chapter 5—Wiring	21
Wiring CTs, PTs, and Control Power	21
Control Power Transformer (CPT) Sizing	22
Control Power Fuses	22
Metering Potential Transformers (PTs)	22
CE Compliance	22
Deriving Control Power from Phase Voltage Inputs	31
Grounding the Power Meter	32
Solid-State KYZ Pulse Output	33
Chapter 6—Communications	35
Protocols	35
POWERLOGIC Protocol Communications Wiring	35
Connecting to a Personal Computer via POWERLOGIC Communications	36
Connecting to a POWERLOGIC Network Interface Module (PNIM) Using POWERLOGIC Communications	37
Connecting to a SY/MAX Programmable Controller Using POWERLOGIC Communications	38
Modbus RTU Protocol	39
Jbus Protocol	39
Connecting to a PC Using Modbus or Jbus Communications	40
Length of the Communications Link (POWERLOGIC, Modbus, or Jbus)	41
Daisy chaining PM&CS Devices (POWERLOGIC, Modbus, or Jbus)	41
Biasing the Communications Link (POWERLOGIC, Modbus, or Jbus)	42
Terminating the Communications Link (POWERLOGIC, Modbus, or Jbus) ..	44

Chapter 7—Display Operation 47

- Introduction 47
- Modes 47
 - Accessing a Mode 48
 - Setup Mode 49
 - Resets Mode 50
 - Diagnostics Mode 50
 - Display Modes 50
 - How the Buttons Work 51
 - Mode* Button 51
 - Arrow Buttons 51
 - Select* Button 51
 - Contrast Button 51
- Setting Up the Power Meter 52
- Performing Resets 54
- Viewing Diagnostic Information 55
- Using Display Modes 55
- Setting Up Onboard Alarms (PM-650 only) 55
- Viewing Active Alarms (PM-650 only) 56

Chapter 8—Metering Capabilities 57

- Real-Time Readings 57
- Min/Max Values (PM-650 Only) 57
- Power Factor Min/Max Conventions 58
- Energy Readings 61
- Power Analysis Values 62
- Demand Readings (PM-620 and PM-650 Only) 63
 - Demand Power Calculation Methods 63
 - Sliding Block Interval Demand 63
 - Block Interval Demand with Subinterval Option 64
 - Synch to Comms 64
 - Predicted Demand 64
 - Peak Demand 64
- KYZ Pulse Output 65
 - Calculating the Pulse Constant 65

Chapter 9—Onboard Alarming (PM-650 Only) 66

- Setpoint-Driven Alarms 66
- Setpoint-Controlled Relay Functions 67
 - Undervoltage 68
 - Unbalance Current 68
 - Unbalance Voltage 68

Chapter 10—Logging (PM-650 Only) 69

- Alarm Log 69
- Event Log 69
- Data Log 69
- Alarm-Driven Data Log Entries 69
- Storage Considerations 69

Appendices

Appendix A—Specifications	70
Appendix B—Dimensions	72
Appendix C—Communication Cable Pinouts	73
Appendix D—Additional Wiring Diagrams	74
Appendix E—Using the Command Interface	79
Appendix F—Register List	81
Appendix G—Modbus and Jbus Functions Supported	101
Appendix H—2-Wire Modbus or Jbus	103
Appendix I—Alarm Setup (PM-650 Only)	104
Appendix J—Calculating Log File Size (PM-650 Only)	108

Illustrations

3-1: Power meter display components	8
3-2: Power meter display, front and back	9
3-3: Front of power meter and terminal shield label	10
4-1: Mounting power meter and display on panel with existing ammeter/voltmeter cutout	15
4-2: Mounting power meter on panel with no existing cutout	17
4-3: Panel mount for the power meter display	17
4-4: Mounting power meter on 35 mm DIN rail	19
5-1: Clamp-on ferrite and disconnect breaker for CE compliance	23
5-2: Opening the clamp-on ferrite	23
5-3: 3-phase, 3-wire delta direct voltage connection with 2 CTs	24
5-4: 3-phase, 3-wire delta with 2 PTs and 2 CTs	25
5-5: 3-phase, 3-wire delta with 2 PTs and 3 CTs	26
5-6: 3-phase, 4-wire wye, ground and direct voltage connection, with 3 CTs	27
5-7: 3-phase, 4-wire wye, ground connection, with 3 PTs and 3 CTs	28
5-8: DC control power wiring	29
5-9: Power meter wire routing	30
5-10: KYZ pulse output	33
5-11: Typical KYZ pulse output connection for use as an alarm contact	34
6-1: Power meters connected to a personal computer via SY/LINK card	36
6-2: Power meters connected to a PNIM	37
6-3: Power meters connected to a SY/MAX programmable controller	38

6-4: Power meters connected to a personal computer via serial port 40
6-5: Daisy chaining the RS-485 communications terminals 42
6-6: Connecting the power meter as the first device
 on a PM&CS or Modbus communications link 42
6-7: Terminating power meter with MCTAS-485 44
6-8: Terminating power meter with terminal block and MCT-485 45
7-1: Navigating power meter parameters 48
7-2: Power meter display buttons 51
7-3: Power meter setup flowchart 53
8-1: Power factor min/max example 59
8-2: Default VAR sign convention 59
8-3: Alternate VAR sign convention 60
9-1: How the power meter handles setpoint-driven alarms 67
9-2: Sample event log entry 67
B-1: Dimensions of power meter and display 72
D-1: 240/120 V 1-phase, 3-wire direct voltage connection with 2 CTs 76
D-2: 3-phase, 4-wire delta with 3 PTs and 3 CTs 77
D-3: 3-phase, 4-wire wye, 3-wire load with 3 PTs and 2 CTs 78
H-1: 2-wire Modbus or Jbus wiring 103

Tables

1-1: Summary of Power Meter Instrumentation 2
1-2: Class 3020 Power Meters and Accessories 2
1-3: Components for assembling custom length cables 2
1-4: Power Meter Feature Comparison 3
4-1: Typical Locations for Mounting Display 12
5-1: System Connection Types 21
5-2: Control Power Transformer Sizing 22
6-1: Maximum Distances of Comms Link at Different Baud Rates 41
6-2: Labeling the CAB-107 Leads 43
7-1: Selecting Voltage Ranges for System Types 50
7-2: Factory Defaults for Power Meter Setup Parameters 52
8-1: Real-Time Readings 57
8-2: Energy Readings 61
8-3: Power Analysis Values 62
8-4: Demand Readings 63
D-1: Power Meter System Wiring Connections 75
H-1: Maximum Distances of 2-Wire Modbus or Jbus
 Comms Link at Different Baud Rates 103