

XVU Wiring Guide

1) DC 24V application:

If customers use **DC Body (not AC Body)**, the wiring should be as below two picture, both below two wiring methods can work well.

DC24V Control Application

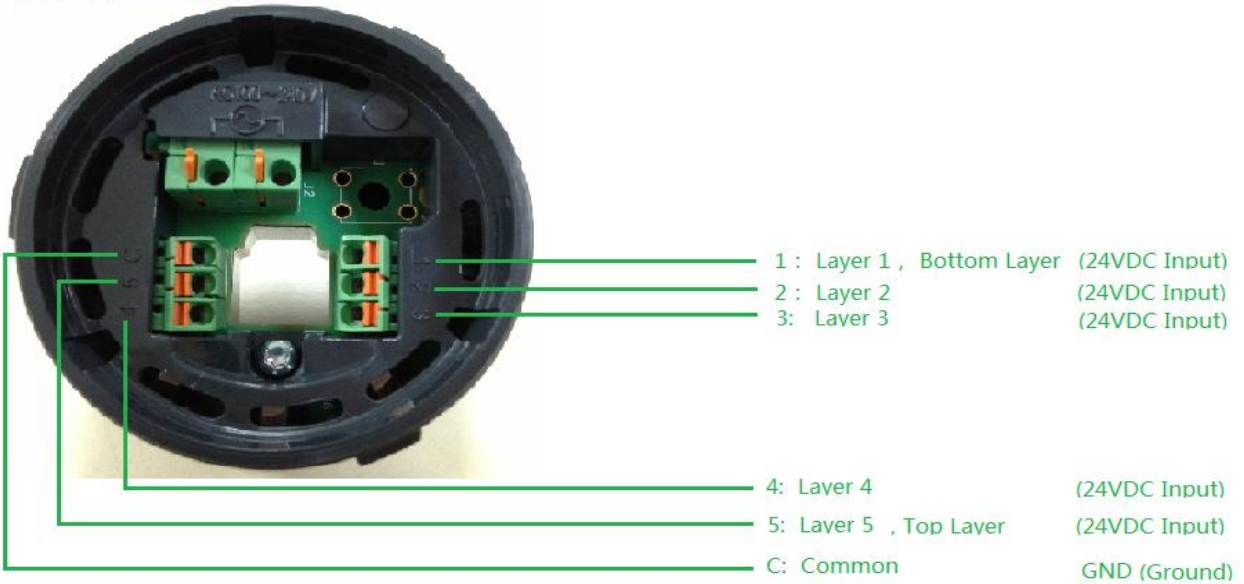

DC24V Control Application

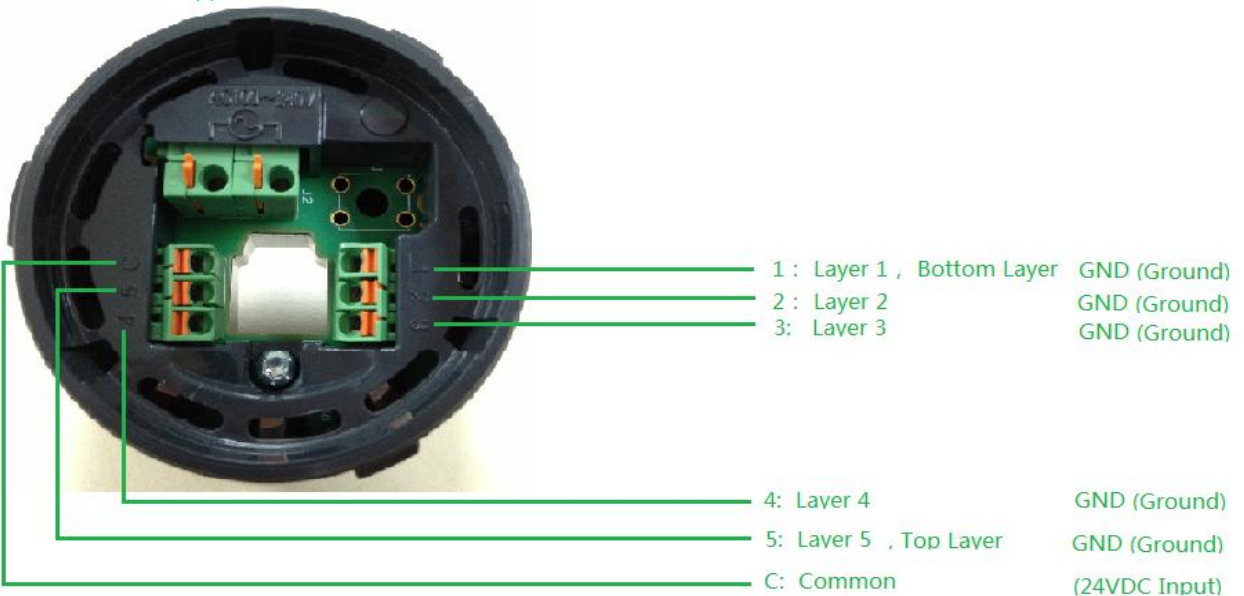

Customer can use switch, PLC and etc to control XVU modules. Below are the examples:

Example 1: Using a **PNP type** PLC to control XVU LED modules and Voice module.

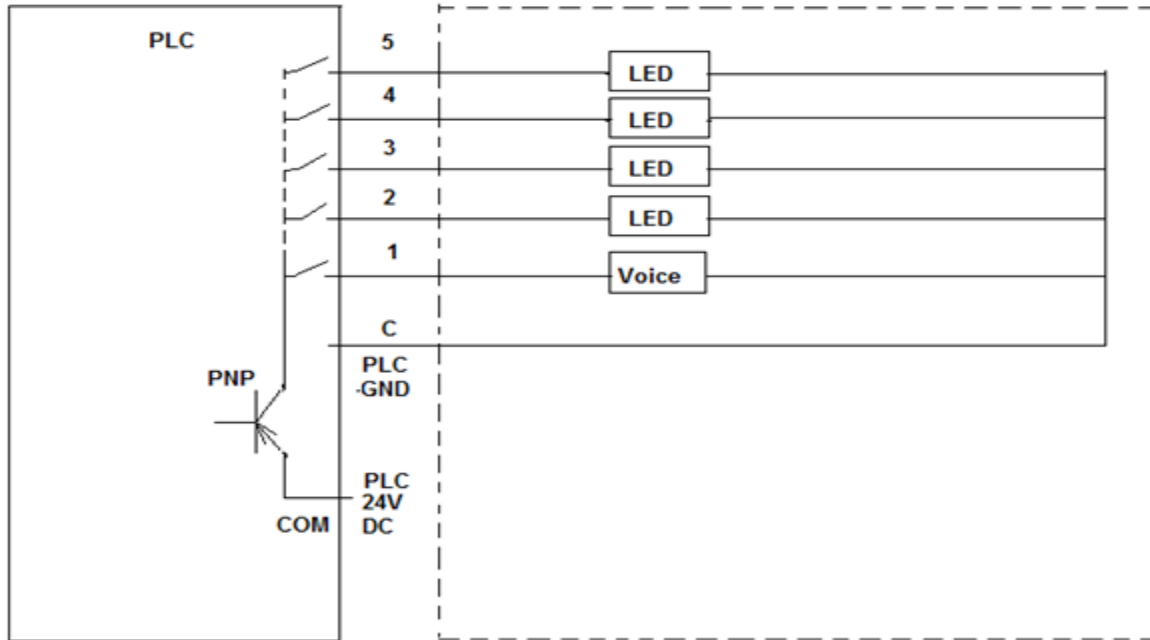

Example 2: Using a **NPN type** PLC to control XVU LED modules and Voice module.

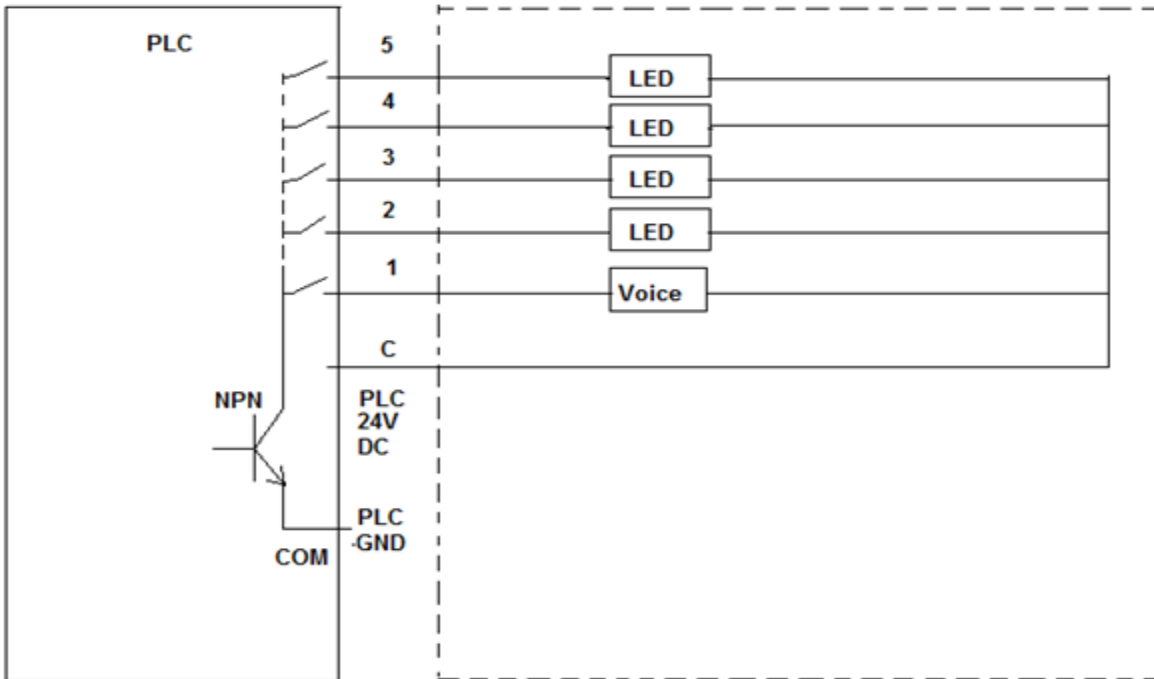

XVB Application – wiring guide

