

9049 - A6 with options

The **9049A6** and **A6C** float assemblies are designed for use with 9036 and 9038 float switches.

The **A6** uses a float tapped and threaded at the top to be fixed to the end of the tubing.

This configuration is used where liquid level changes are relatively small. For large changes, see 9049A6C.

Aluminum or stainless steel rods and stops may be specified by adding a suffix letter to the part number.

9049A6 Operation:

Contact change on rising levels:

Adding liquid to the tank will cause the float to raise and lift the rod. When the lower stop on the rod touches the float switch actuating lever, the float will submerge in the liquid. The float is designed to submerge 80 % before it generates enough lifting force to change the state of contacts in the float switch.

Contact change on falling levels:

Removing liquid from the tank will cause the float to fall and lower the rod. When the upper stop on the rod falls far enough, the weight of the float and rod will rest on the actuating lever. When the float and rod exert enough force downward, the state of contacts in the float switch will change.

When moving the float, occasionally one can hear the sound of metal inside the float. This is weight added to create the force needed to change contact state on falling pressure. Remove the weight and the contacts may not change state when all the liquid is removed.

The standard float can handle Specific Gravities to 0.8, the density of Diesel Fuel. At this density, however, the float may appear fully submerged before contacts change state on liquid rise.

Extending the Rod

The rod length supplied is 5 ft. Additional 2.5 foot lengths may be added. Each additional rod length will come with a threaded connector which will allow sections to be joined together. As rod lengths increase, the weight of the rod increases as well. A compensating spring may be required in some applications to offset the weight of the rod. There is a maximum rod length where the rod and float weight, coupled with the compensating

spring, allow only enough force to be generated to change the contact state on liquid rise.

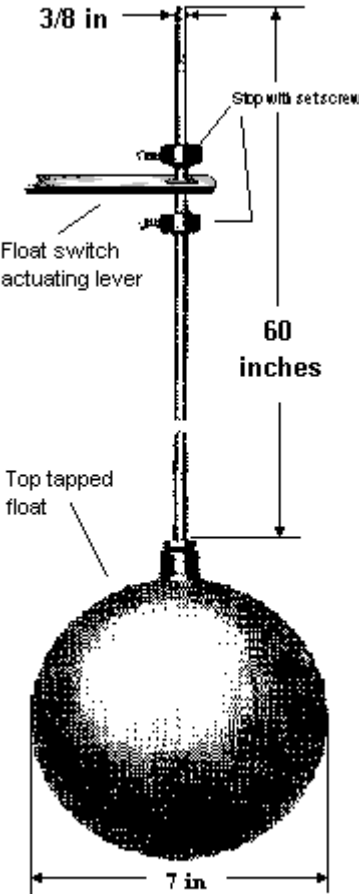

Type A-6

Replacement Parts:

| | | |
|------------------|--------------|-----------------|
| Stops | 1091 S14 G1 | Brass |
| | 1091 S15 G1 | Stainless Steel |
| Set Screw | 297 D3 X20 | Brass |
| | 65006 006 01 | Stainless Steel |

| | | |
|--|---------|---|
| Rod section of brass rod and connector | 9049T1 | 2 1/2 foot |
| | 9049T1A | 2 1/2 foot section of aluminum rod and connector |
| | 9049T1S | 2 1/2 foot section of stainless steel rod and connector |

| | | |
|------------------|------------|-------|
| Connector | 297 D3 X20 | Brass |
|------------------|------------|-------|

The **A6C** uses a float with a hole through its center, allowing this float to move up and down the length of the tubing.

Aluminum or stainless steel rods and stops may be specified by adding a suffix letter to the part number.

9049A6C Operation:

Center hole floats rise and fall along the rod, suited for large changes in liquid level

Contact change on rising levels:

Adding liquid to the tank will cause the float to raise. It will slide up the rod as the liquid level increases. When the float raises enough to touch a stop on the rod, the float will begin to lift the rod when more liquid is added. As the rod raises, it lifts a stop to contact the float switch actuating arm. When the stop touches the switch actuating lever, the float will submerge as more liquid enters the tank.. The float is designed to submerge 80 % before it generates enough lifting force to change the state of contacts in the float switch.

Contact change on falling levels:

Removing liquid from the tank will cause the float to fall and lower the rod. When the upper stop on the rod falls far enough, the weight of the rod will rest on the actuating lever. As more liquid leaves the tank, the float will contact a lower stop, and add its weight to that of the rod, all resting on the float switch actuating lever. When the float and rod exert enough force downward, the state of contacts in the float switch will change.

When moving the float, occasionally one can hear the sound of metal inside the float. This is weight added to create the force needed to change contact state on falling pressure. Remove the weight and the contacts may not change state when all the liquid is removed.

The standard float can handle Specific Gravities to 0.8, the density of Diesel Fuel. At this density, however, the float may appear fully submerged before contacts change state on liquid rise.

Extending the Rod

The rod length supplied is 5 ft. Additional 2.5 foot lengths may be added. Each additional rod length will come with a threaded connector which will allow sections to be joined together. As rod lengths increase, the total weight of the rod and float assembly increases as well. A compensating spring allows longer rod

lengths that the float alone could not lift. Based on the different weights of the brass, aluminum and stainless steel, each different material will have a different maximum length with or without the compensating spring.

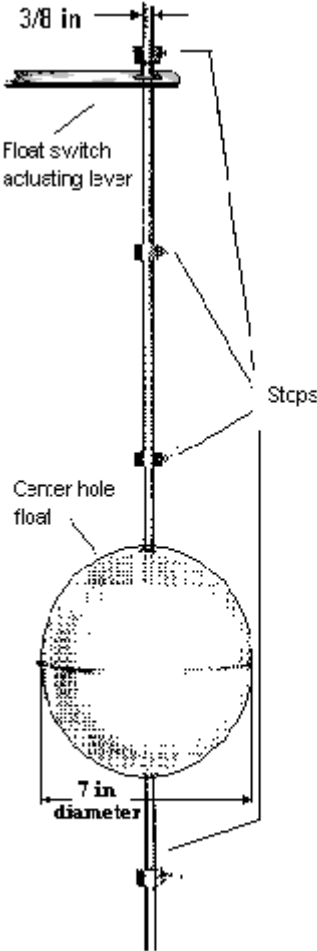

Type A-6C