

Operation

Symmetra[®] MW II

Parallel System
with Internal Bypass
Static Switch

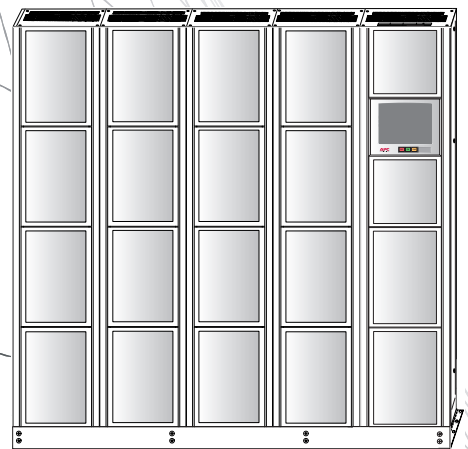



Contents

Overview	1
Navigation Tree.	1
Display Symbols and Buttons.	2
Navigation symbols	2
Screen symbols	2
Buttons	3
Breakers	3
How to Access the Summary Screens.	4
From the UPS Parallel System screen	4
From the UPS Summary screen	5
How to Access the APC Symmetra MW II Remote Display.	6
How to start a web-based remote session	6
Operation	7
Operation Modes	7
Normal operation	7
Battery operation	7
Static bypass operation	8
Manual bypass operation	8
Operation Procedures	9
How to access screens protected by the user-password	9
How to transfer the system from normal to manual bypass operation	9
How to start up the system from manual bypass operation ..	10
How to transfer from normal to static bypass operation	11
How to transfer from static bypass to normal operation	12

Configuration 15

How to Configure the System 15

How to change the password	16
How to configure the Touch-Screen Settings screen	17
How to configure the Modbus Settings screen	17
How to configure the Regional Settings screen	18
How to configure the Network Configuration screens	19
How to configure the Display Settings	22
How to configure the Battery Test Settings screen	23

Maintenance 25

Predictive Maintenance Screens 25

How to access the Predictive Maintenance screens	25
Inverter DC Capacitors screen	25
Inverter AC Capacitors screen	26
Top Fans screen	26
Inverter Fans screen	27
Main Static Switch Fans screen	27

How to Change the Air Filters 28

Troubleshooting 29

Alarm Types. 29

Info	29
Warning	29
Severe	29
How to silence the alarm	29
How to view active alarms	30
How to view the event log	30

Overview

Navigation Tree

The UPS display is the user interface to the UPS parallel system, and is located in the control section. The LCD touch-screen display is used to configure the system, monitor the system, and change the settings. The display also provides the user with audible and visual alarms.

The screens are organized hierarchially with the UPS Parallel System screen at the top of the hierarchy.

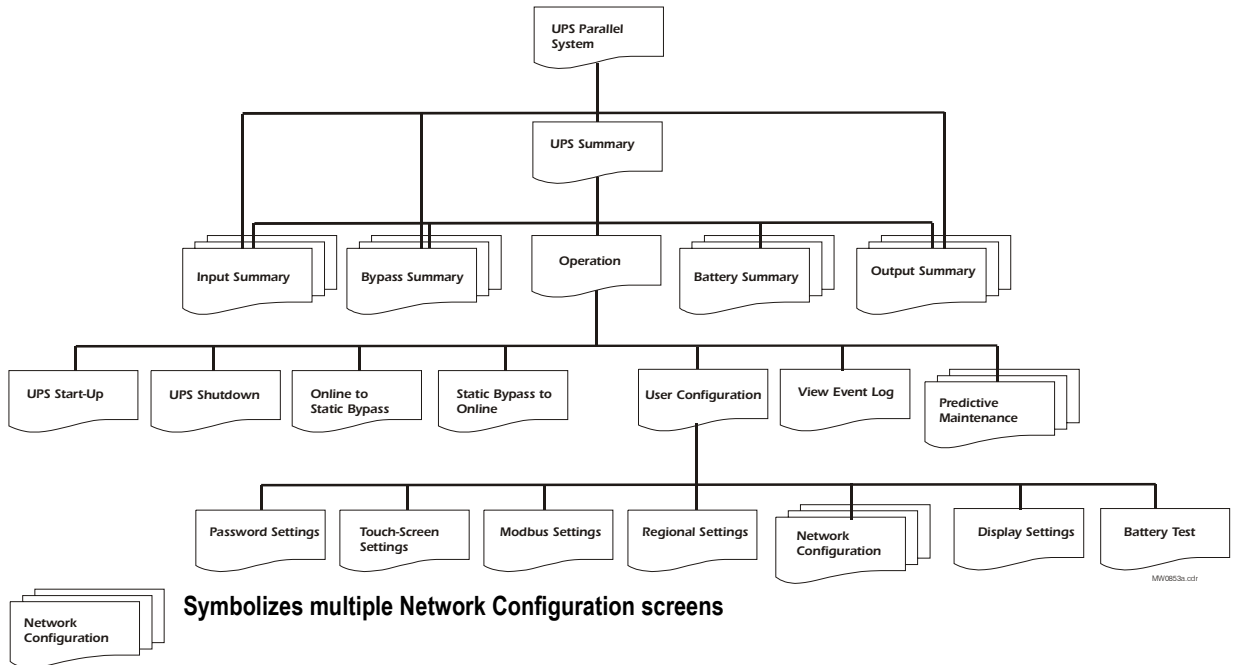

Display Symbols and Buttons

Navigation symbols



Home: Go to the top of the hierarchy.



Back: Go to the previous screen.



Help: Access further details on the current screen.



Operation: Go to the Operation screen.



Page Up: Go to the previous screen on the same subject (only visible when there are more screens on the same subject).



Page Down: Go to the next screen on the same subject (only visible when there are more screens on the same subject).



Password Logout: Log out of the password-protected screens.



System Input: Access the Input Summary screens.



System Output: Access the Output Summary screens.



Static Switch: Access the Bypass Summary screens.



Battery: Access the Battery Summary screens.



Alarm button: Access the Active Alarms screen

Screen symbols



Delta inverter



Main inverter



Open breaker or switch



Closed breaker or switch

Buttons

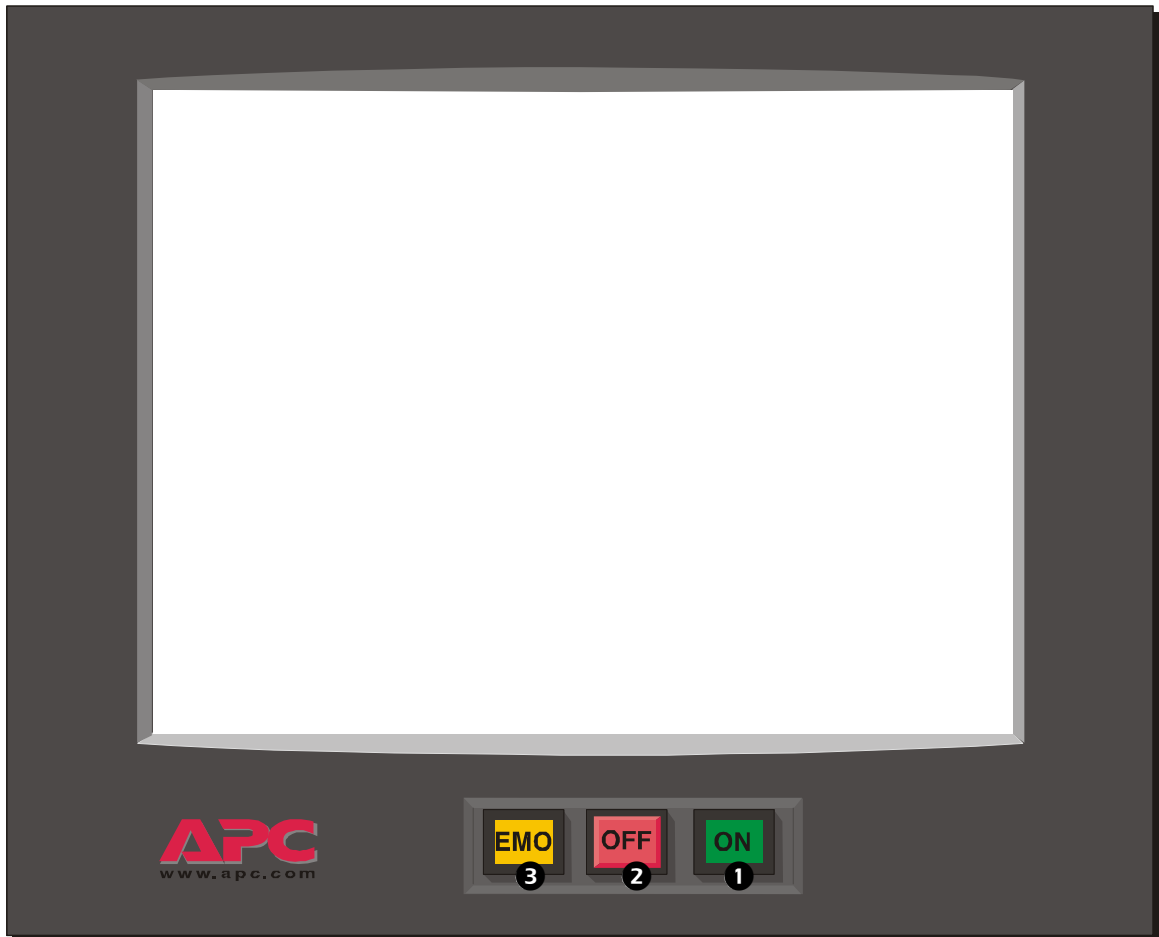

1. ON button: Press this button to switch ON the UPS.
2. OFF button: Press this button to switch OFF the UPS.
3. EMO (Emergency Module OFF) button: To be used in emergency situations only. Pressing this button switches OFF all breakers, disabling AC/DC input and output in this section. Be aware that this action may cut the supply to the load from the affected section.

Breakers

Q1	UPS input breaker	Q5	Static bypass input breaker
Q2	UPS output breaker	Q7	Battery breaker 1
Q3	Manual bypass breaker	Q8	Battery breaker 2
Q4	System output breaker		



Note: Only operate a breaker when the associated breaker lamp is on.

How to Access the Summary Screens

From the UPS Parallel System screen

The UPS Parallel System screen provides you with an overview of the parallel system and circuit breakers. It shows the system status and the power flow through the system and gives access to the system's summary screens.



Note: The operated UPS is highlighted on the screen and the other UPS units are faded out.

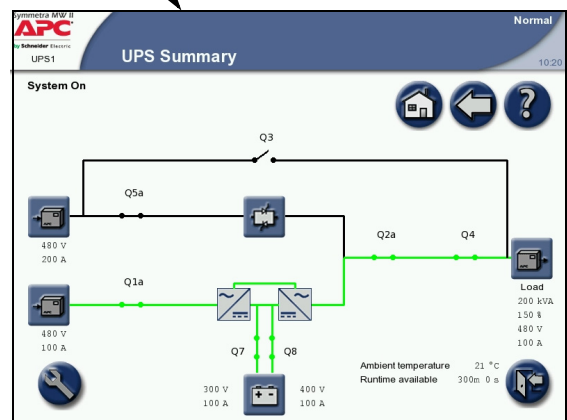
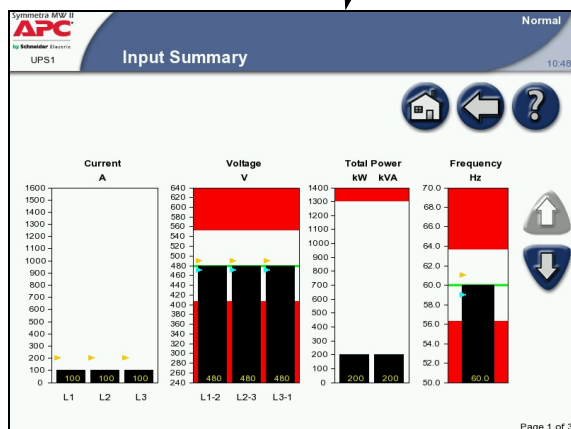
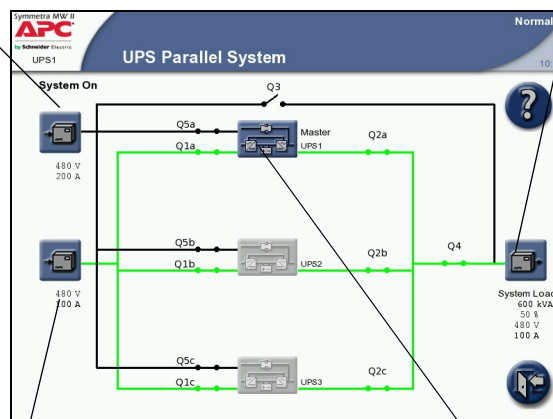
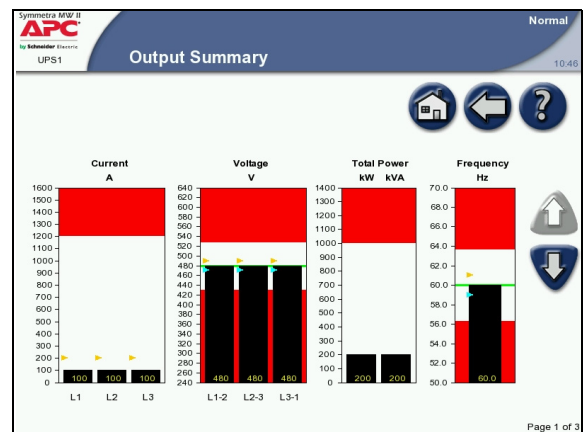
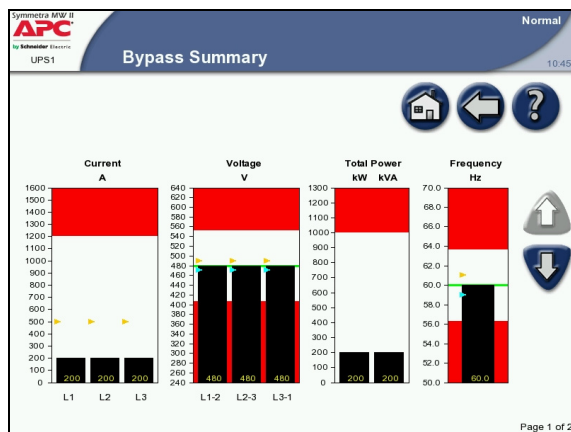

From the UPS Summary screen

The UPS Summary screen provides you with an overview of the actual UPS and circuit breakers. It shows the system status and the power flow through the UPS and gives access to the system's summary screens and the Operation screen.

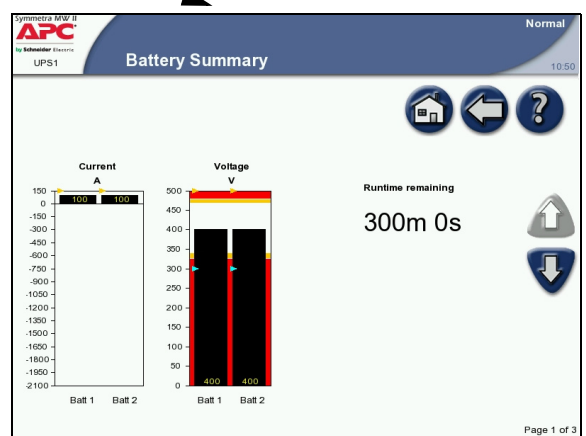
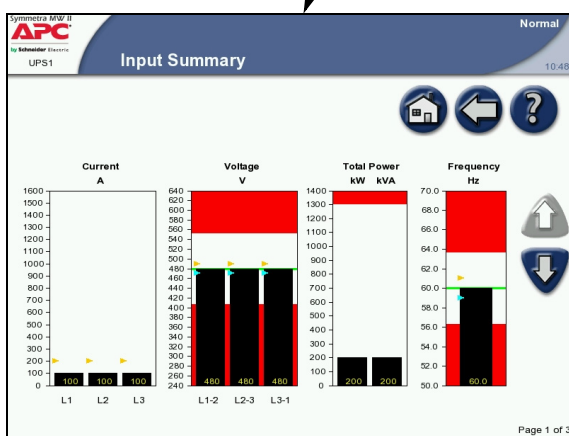
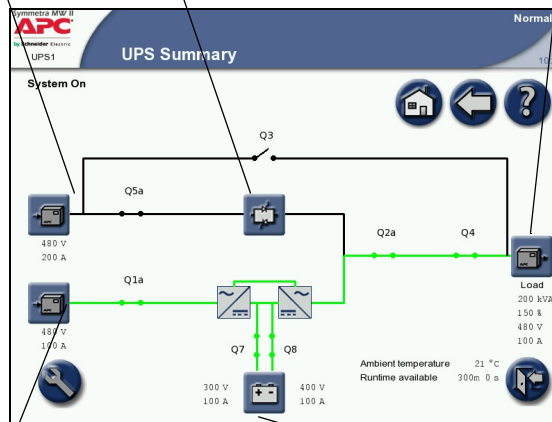
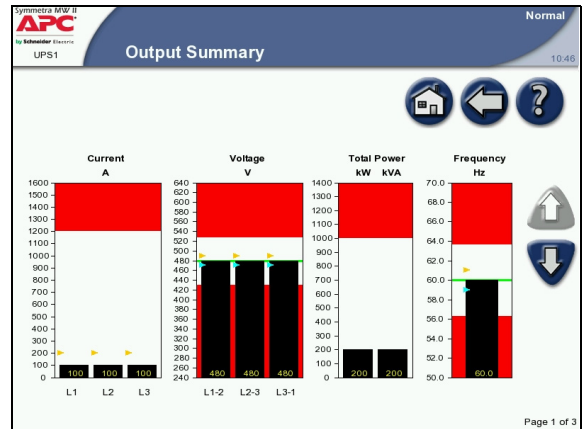
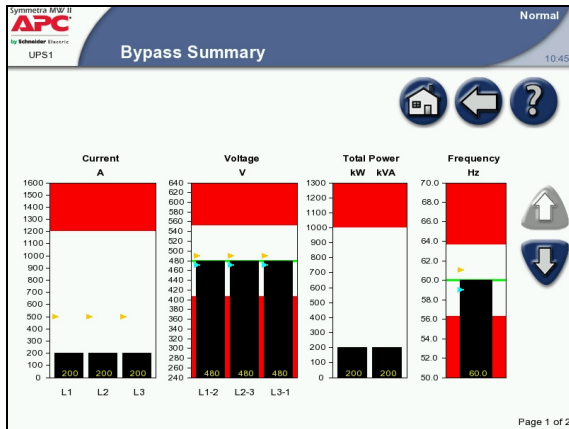

How to Access the APC Symmetra MW II Remote Display

The read-only display screens can be accessed via an Internet Browser by typing the IP address of the Symmetra MW II display into the browser's address field. Configuration of the Symmetra MW II or the display through the remote display is not supported.

The remote display feature requires Microsoft Internet Explorer 6 SP1 or greater. For best results we recommend that the Sun JVM version 1.4.2_05 or greater is installed, which is available from the Sun website.

The Netscape browser is not supported.



Note: Operation/configuration must be done at the UPS.



Note: The event log screen can be accessed through the Operation screen. Only the 50 most recent events in the Event Log screen can be downloaded.



Note: Network settings must be configured before the remote display feature can be used.

How to start a web-based remote session

- Start the web-based remote session by entering the IP address of the APC Symmetra MW II UPS in the web browser address field. After a few seconds, a new window will open and display the screen as shown opposite.
- Use the mouse to touch the buttons to see the other screens.
- Close the window or the web browser to end the remote session.

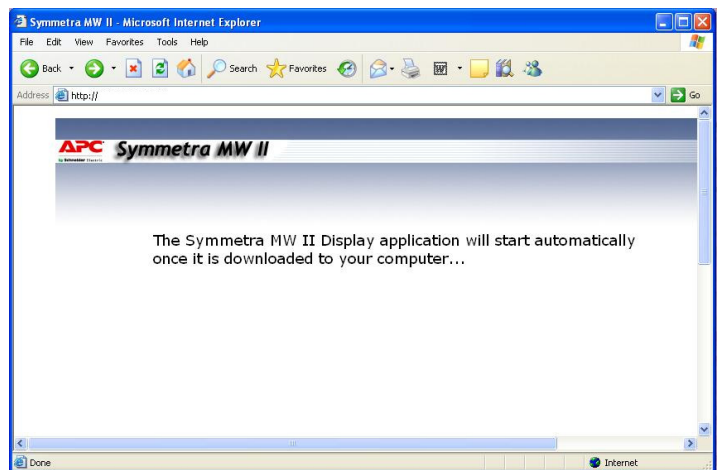

Note: If the Remote Display Inactivity Time-out on the APC Remote Display Settings screen is set to Never, the session must be manually terminated by closing the remote display session.



Note: Only one remote session at a time is allowed.

Operation

Operation Modes

Normal operation

During normal operation, the critical load is supported by the inverters. While the UPS is running in this mode, a single-line diagram will appear on the screen. The green line indicates the power flow from the utility supply through the UPS to the load.

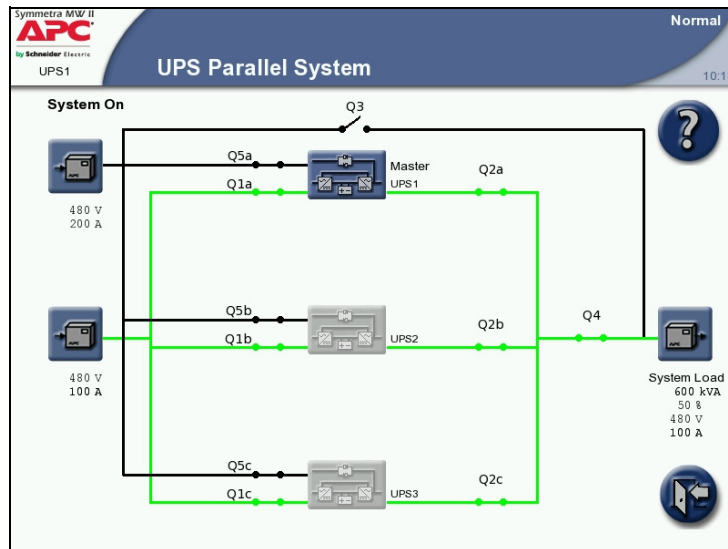

Battery operation

During battery operation, the load is supported by the inverters. The inverters are supplied by battery power, ensuring uninterrupted support to the load.

While the UPS is running in battery operation, a single-line diagram will appear on the screen with a green line indicating the power flow from the batteries through the main inverter to the load for as long as the batteries are energized.

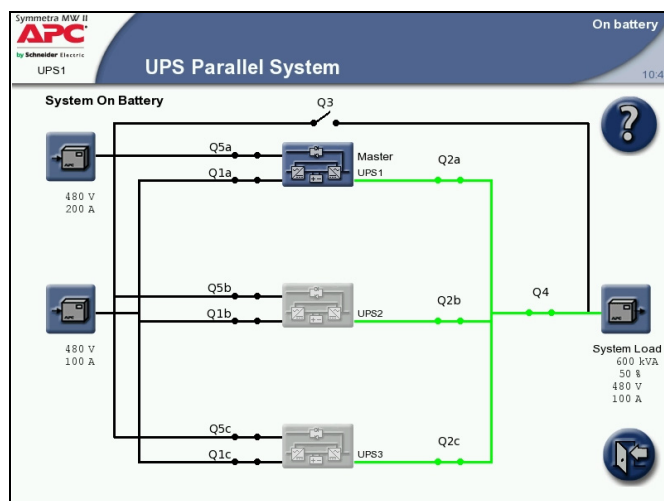

Static bypass operation

During static bypass operation, the critical load is supplied directly by utility power. A single-line diagram will appear on the screen with an orange line indicating the power flow through the Bypass SSW to the load.



Caution: Do not open Q2 or Q5 when the UPS is in bypass operation, as this action may result in a load drop or a failure of the UPS to support the load.

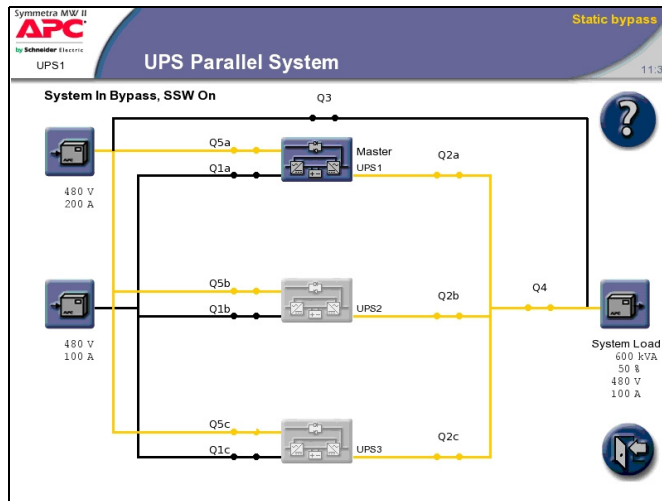

Manual bypass operation

During manual bypass operation, the critical load is supplied directly by utility power. Manual bypass allows the UPS units to be isolated for maintenance purposes. In manual bypass there is no backup from the UPS system to the load. While the UPS system is operating in this mode, a single-line diagram will appear on the screen with an orange line indicating the power flow from the utility to the load through the Q3 breaker.

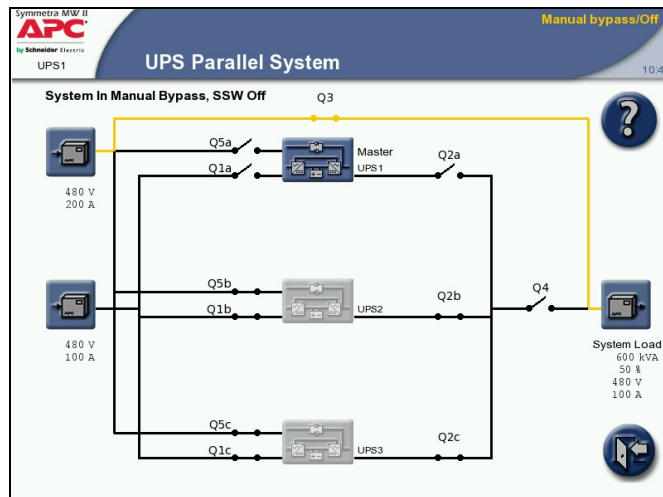

Operation Procedures

How to access screens protected by the user-password

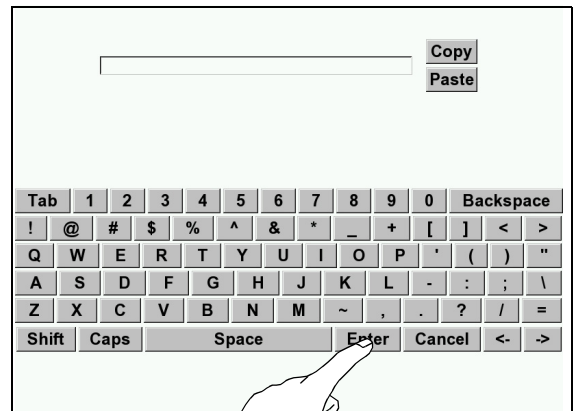
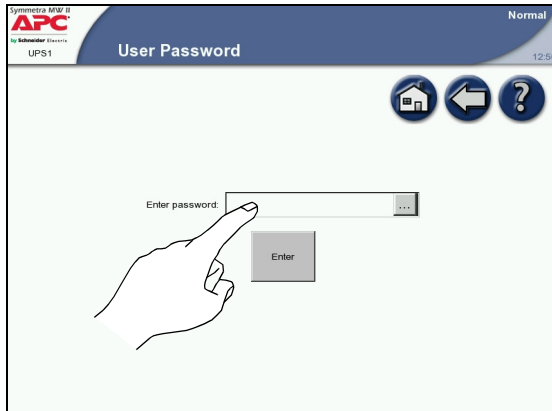

1. When prompted for the user-password, press the password field to access the keyboard.
2. Type in the user password and press **Enter**.
Note: On installation, the user-password is set to apc.

How to transfer the system from normal to manual bypass operation



Note: The UPS Shutdown screen on this page shows an example of a generic shutdown sequence. Follow and complete the shutdown sequence as shown on your UPS Shutdown screen.

1. Press the highlighted UPS on the UPS Parallel System screen.
2. Press the **Operation** button on the UPS Summary screen.

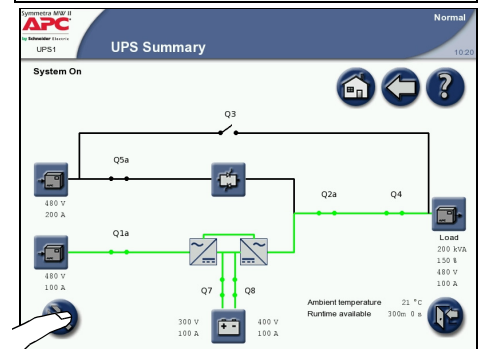
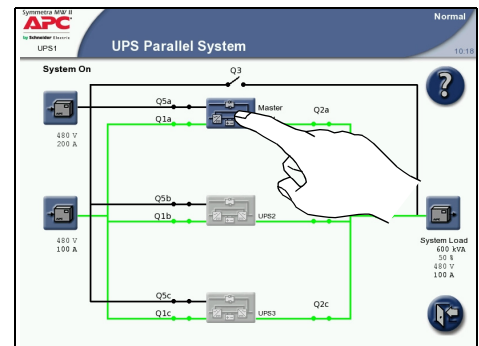

- Press the **Shutdown** button. Press inside the password field and type in the user password using the keyboard on the screen. Complete with ENTER.

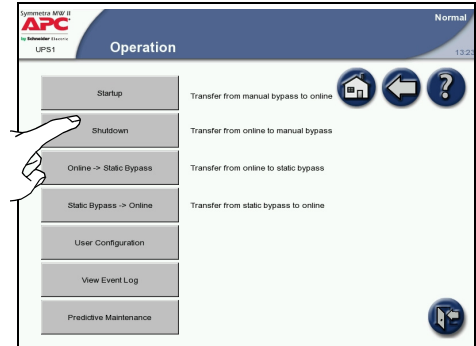

- Follow the procedure on the screen which is specific to your system.

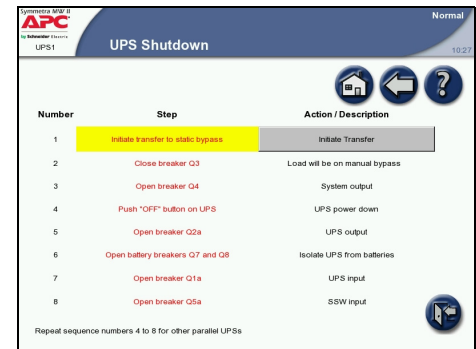

How to start up the system from manual bypass operation



Note: The UPS Startup screen on this page shows an example of a generic start-up sequence. Follow and complete the start-up sequence as shown on your UPS Start-Up screen.

- Close the Q1 (and Q5 if applicable) breaker in the external maintenance bypass panel to power up the internal power supply. Wait for the display to become active.
- Press the highlighted UPS on the UPS Parallel System screen.

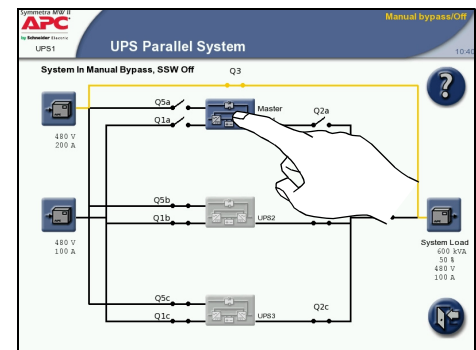

- Press the **Operation** button on the UPS Summary screen.

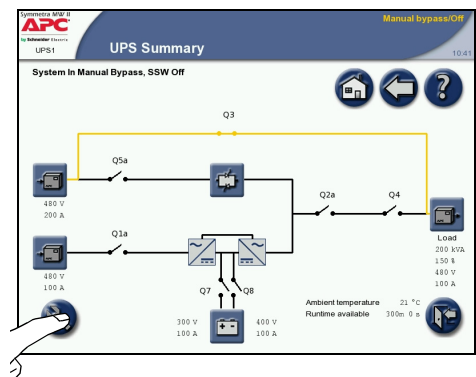

- Press the **Startup** button. Press inside the password field and type in the user password using the keyboard on the screen. Complete with ENTER

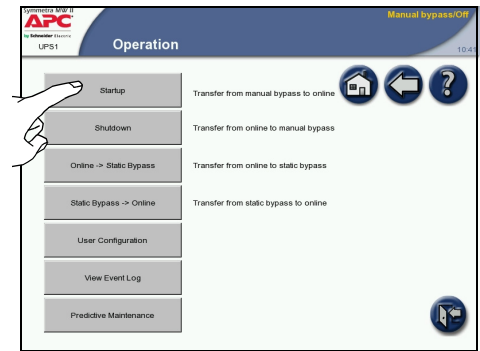

- The UPS Start-Up screen appears with the Charge DC Capacitors step highlighted. Follow the procedure on the screen which is specific to your system.

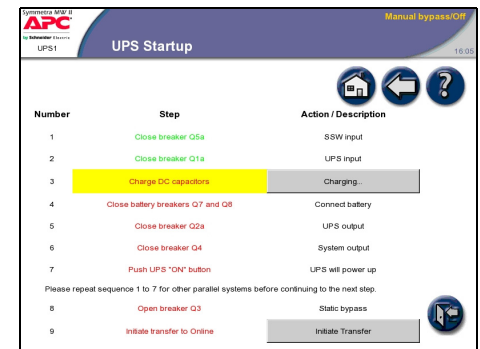

- Verify that the status in the upper right corner has changed to Normal.



How to transfer from normal to static bypass operation

- Press the highlighted UPS on the UPS Parallel System screen.

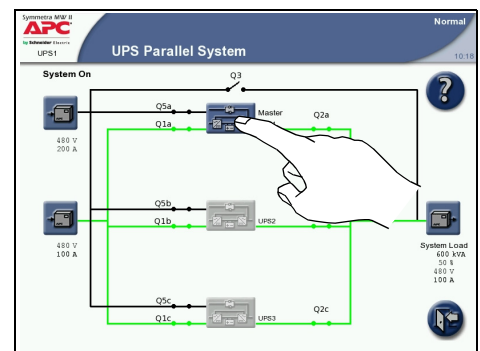

- Press the **Operation** button on the UPS Summary screen.

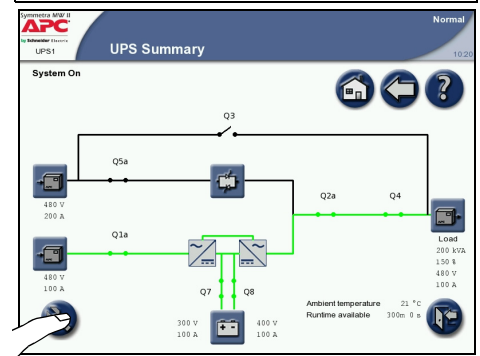

3. Press the **Online -> Static Bypass** button. Press inside the password field and type in the user password using the keyboard on the screen. Complete with ENTER.

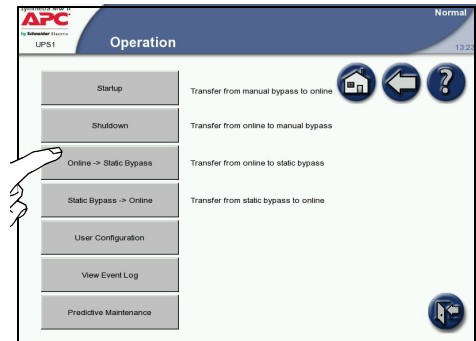

4. Press **Initiate Transfer**.

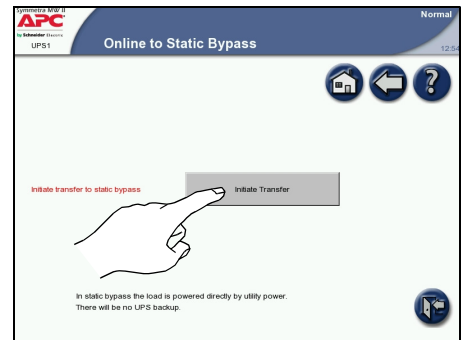

5. Verify that the status in the upper right corner has changed to Static Bypass.



How to transfer from static bypass to normal operation

1. Press the highlighted UPS on the UPS Parallel System screen.

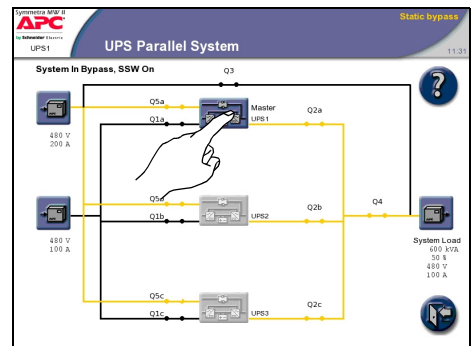

2. Press the **Operation** button on the UPS Summary screen.

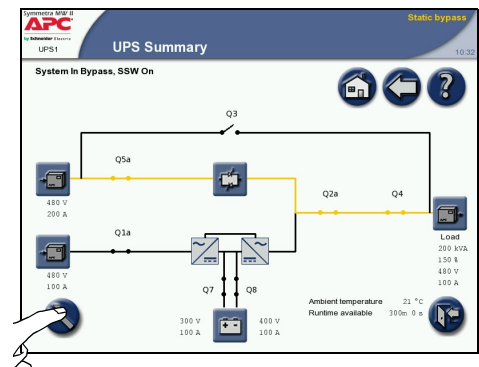

3. Press the **Static Bypass -> Online** button. Press inside the password field and type in the user password using the keyboard on the screen. Complete with ENTER.

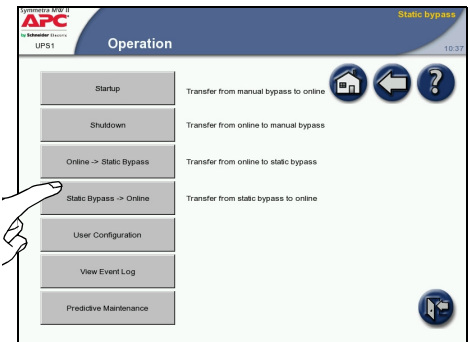

4. Press **Initiate Transfer**.

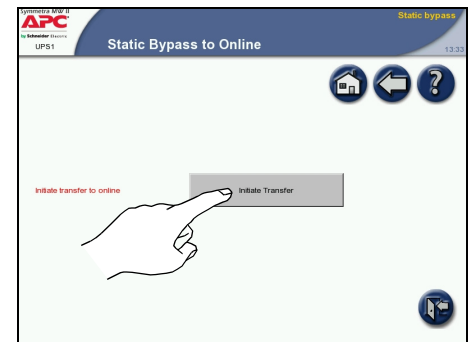

5. Verify that the status in the upper right corner has changed to Normal.



Configuration

How to Configure the System

The UPS is configured from the password-protected user configuration area of the display.



Note: On installation, the user password is set to apc.

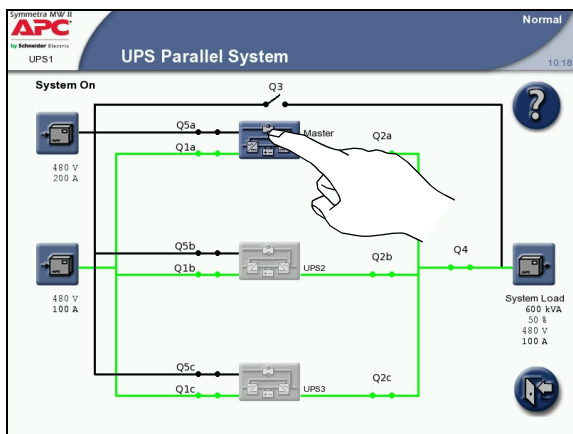

1. Press the highlighted UPS.

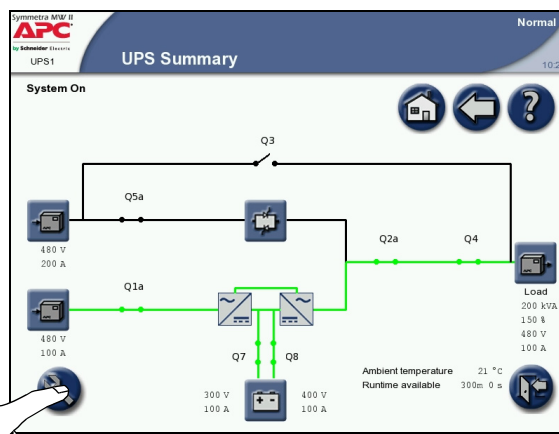

2. Press the **Operation** button in the bottom left corner to access the Operation screen.

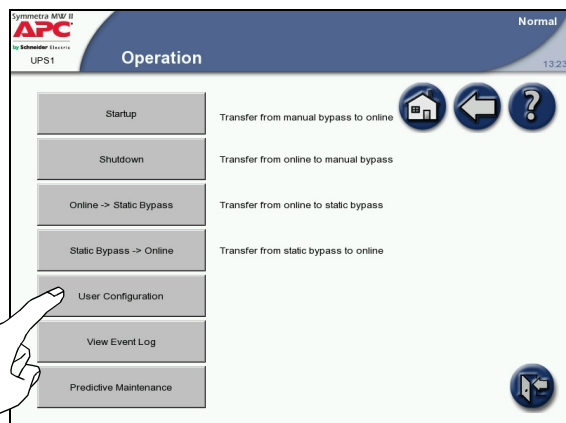

3. Press the **User Configuration** button and then press the page down symbol on the screen until you reach the settings, that you want to configure.

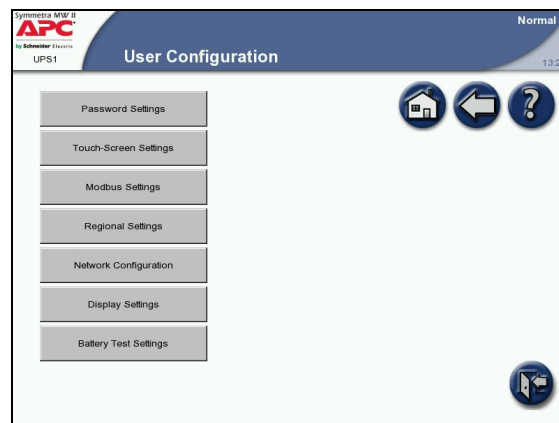

4. Select the parameter that you wish to set.

How to change the password

1. Press the **Password Settings** button on the User Configuration screen to access the Password Settings screen.

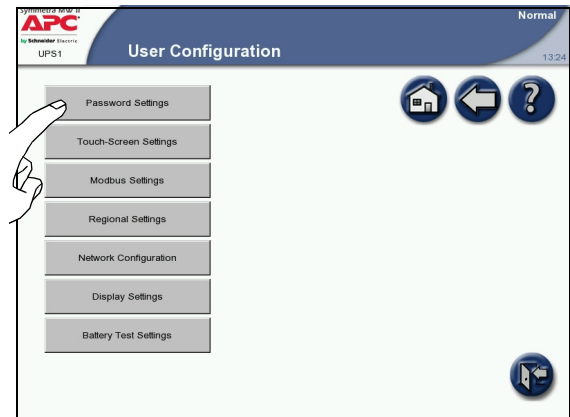

2. Change the user password:
 - Press the **Enter current password** field and type the current password by using the keyboard in the screen. Complete with **ENTER**.
 - Press the **Enter new password** field and type the new password by using the keyboard on the screen. Complete with **ENTER**.
 - Press the **Re-enter new password** field and re-type the new password. Complete with **ENTER**.

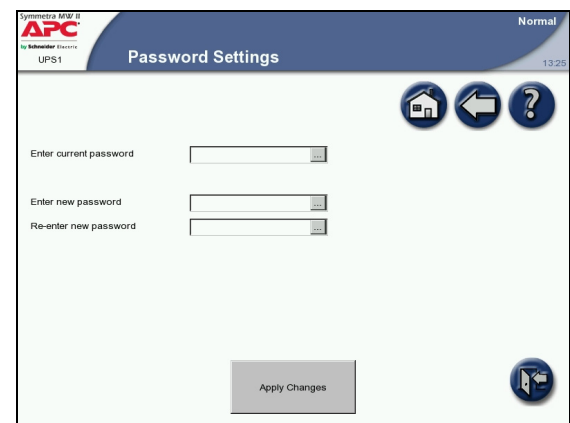

3. Press **Apply Changes** to complete the password change procedure.

How to configure the Touch-Screen Settings screen

1. Press the **Touch-Screen Settings** button on the User Configuration screen to access the Touch-Screen Settings screen.

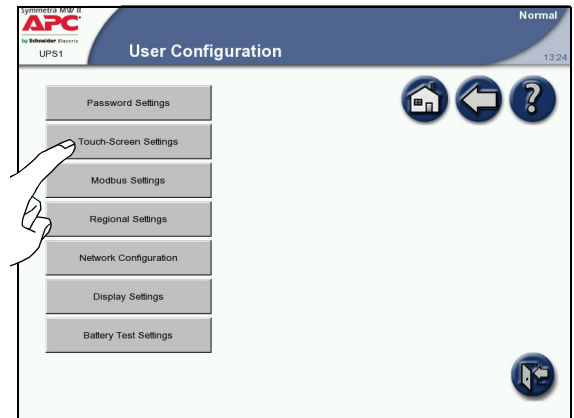

2. Change the touch-screen settings:

- Brightness: Place the finger on the indicator and slide it left or right to the desired setting.
- Contrast: Place the finger on the indicator and slide it left or right to the desired setting.
- Backlight mode: Select “Always on” or “Off after inactivity”.
- Backlight timeout (minutes): Select the time limit for turning off the screen backlight.

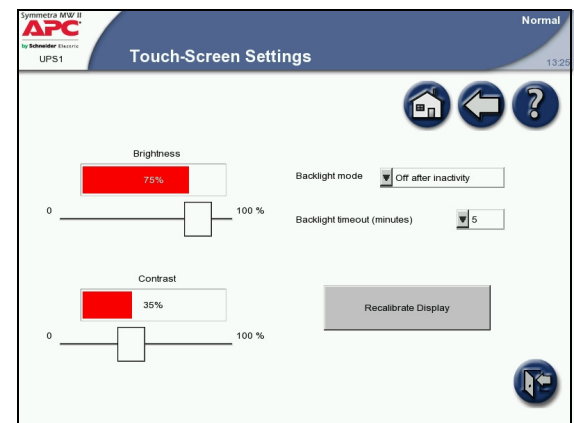

- Recalibrate Display: Press this button to initiate the calibration of the screen.



Note: If the backlight mode is set to “Always on” this will reduce the lifetime of the display.



Note: If a display reboot is required, it can be achieved by recalibrating the display.

How to configure the Modbus Settings screen

The Modbus Settings screen allows monitoring of the UPS by a Building Management System (BMS).

1. Press the **Modbus Settings** button on the User Configuration screen to access the Modbus Settings screen.

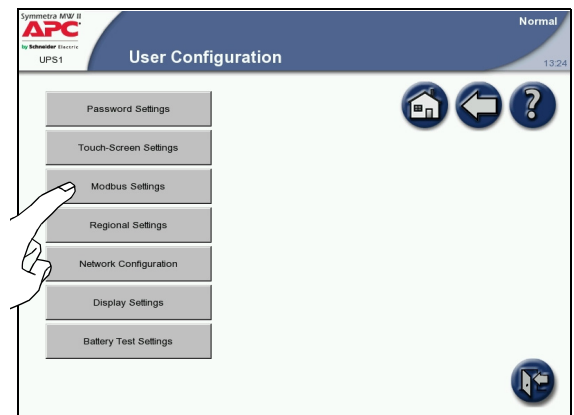

2. Change the modbus settings:
 - BMS modbus RTU address: The modbus address of the UPS device.
 - Baud rate: Select 9600, 19200, 38400, 57600, or 115200.
 - Parity: Select None, Odd, or Even.
3. Press **Apply Changes** to complete the changes.

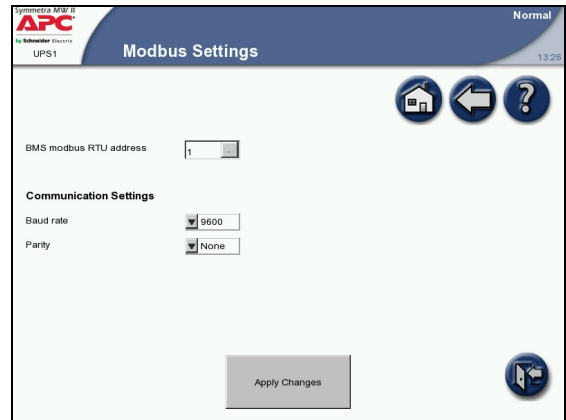

How to configure the Regional Settings screen

1. Press the **Regional Settings** button on the User Configuration screen to access the Regional Settings screen.
2. Change the regional settings:
 - Temperature unit: Select Celsius in 400 V regions and Fahrenheit in 480 V regions.
 - Date format: Select the preferred date format.
3. Press **Apply Changes** to complete the changes.

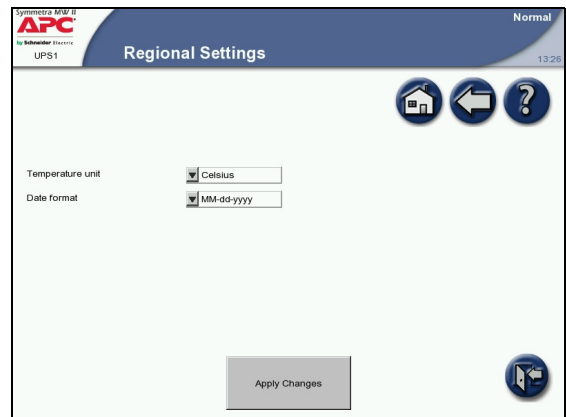
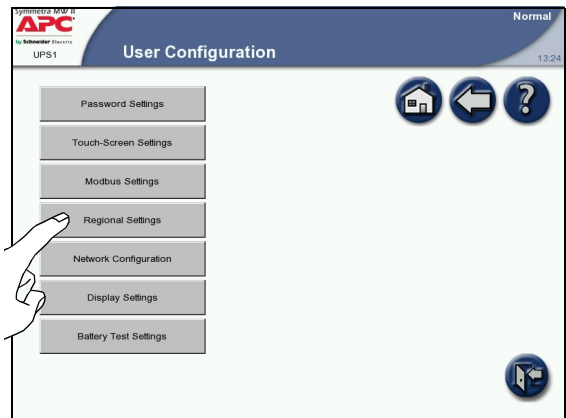

How to configure the Network Configuration screens

All network settings information must be provided before any network functions can be used.

1. Press the **Network Configuration** button on the User Configuration screen to access the Network Configuration screens.

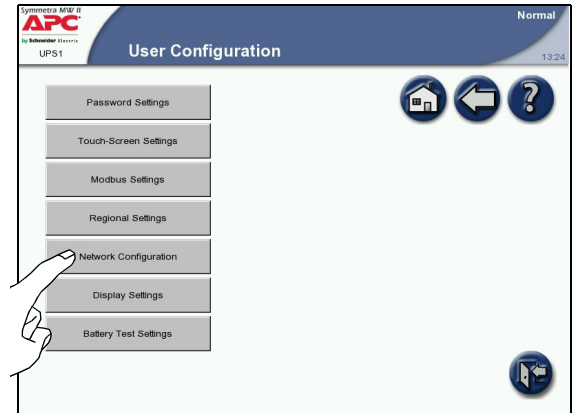

2. Configure the Network Settings screen:

– Enable network: Use this checkbox to connect or disconnect the UPS from the network.

– IP Settings

- IP address: The static IP address.
- Subnet mask: The subnet mask for the network segment containing the UPS.
- Gateway: The network gateway for the segment containing the UPS.

– DNS Settings

- Primary DNS server: The IP address of the DNS server to be used by the UPS (optional).
- Secondary DNS server: The IP address of a backup DNS server if the primary server is not available (optional).

– Host Name Settings

- Host name: The network host name for the system. This uniquely identifies the system on the network. Standard letters (a-z and A-Z), digits (1-9), and hyphen (-) can be used.
- Domain name: The DNS network domain containing the UPS. Standard letters (a-z and A-Z), digits (1-9), and hyphen (-) can be used.

– SMTP Settings

- From address: The source address used when sending e-mails.
- SMTP server: The SMTP server responsible for sending e-mails.

– Press **Apply Changes** to complete the changes and select arrow down to go to the next Network Configuration screen.

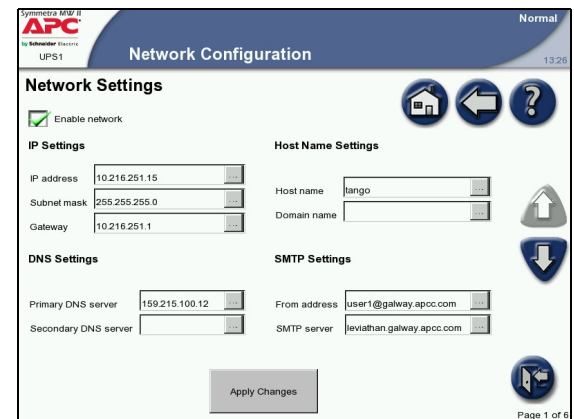



Note: The display will have to be rebooted in order for the changes to the domain name or DNS servers to take effect.

3. Configure the E-mail Settings screen:

- Enable E-mail: Select to enable the e-mail notifications.
- To add a new e-mail recipient, touch the **Add New** button, type in the e-mail address and specify the minimum severity of alarm. All entries will appear in red until **Apply Changes** is pressed.
- To edit or delete an e-mail recipient, select the recipient from the recipient list, and then choose to either update or delete it.
- Apply Changes: Press this button after all changes have been made. Entries will appear in red until this button is touched.
- Send Test E-mail: Pressing this button sends a test e-mail to all configured e-mail recipients. This button can be used to validate the e-mail settings.
- Press arrow down to go to the next Network Configuration screen.

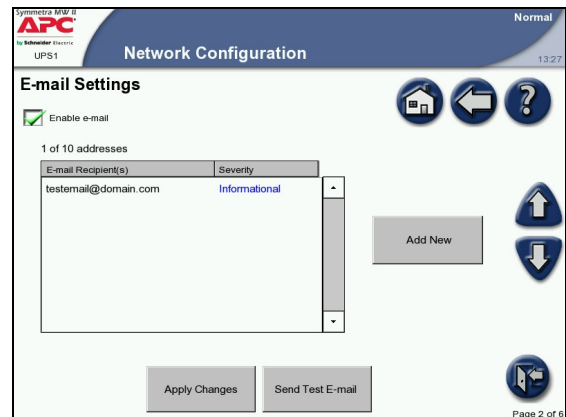

4. Configure the SNMP Settings screen. The UPS can be set to send SNMP traps if UPS alarm conditions occur, and when the conditions return to normal afterwards. Each trap contains a description of the alarm condition. Up to 10 trap receivers can be entered. The trap receiver must have the APC PowerNet MIB (version 3.6.1 or later). The latest version of the PowerNet MIB can be downloaded from www.apc.com.

- Enable SNMP: Enable the SNMP functionality by selecting this checkbox.
- To add a new trap receiver, press the **Add New** button, type in the address and specify the minimum severity of alarm. All entries will appear in red until **Apply Changes** is pressed.
- To edit or delete a trap receiver, select the recipient from the recipient list, and then choose to either update or delete them.
- Apply Changes: Press this button after all changes have been made. Entries will appear in red until this button has been pressed.
- Send Test SNMP: Pressing this button sends a test trap to all configured trap receivers. This button can be used to validate SNMP settings.
- Press arrow down to go to the next Network Configuration screen.

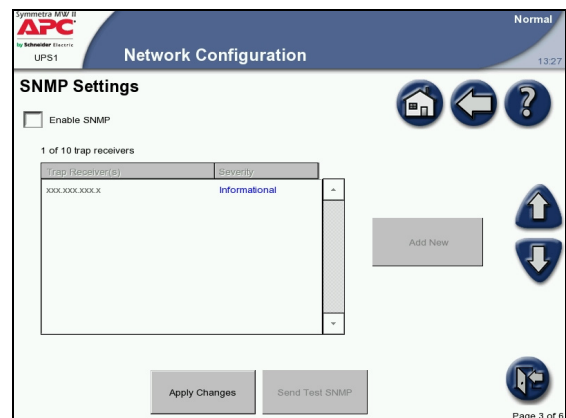

5. Configure the Remote Monitoring Service Settings screen. The APC Remote Monitoring Service (RMS) is an APC professional service which securely monitors the customer's Network-Critical Physical Infrastructure (NCPI) from a remote 24x7 operation center, responding to events according to a pre-defined customer escalation procedure. Go to <http://rms.apc.com> to learn more about this service.

The APC Remote Monitoring Service uses the HTTP protocol to post information to its database. If a proxy server is used for Internet connection, then the required proxy server port settings must be specified (a proxy server acts as an agent between a workstation user or other networked device and the Internet to regulate security, administrative control and caching).

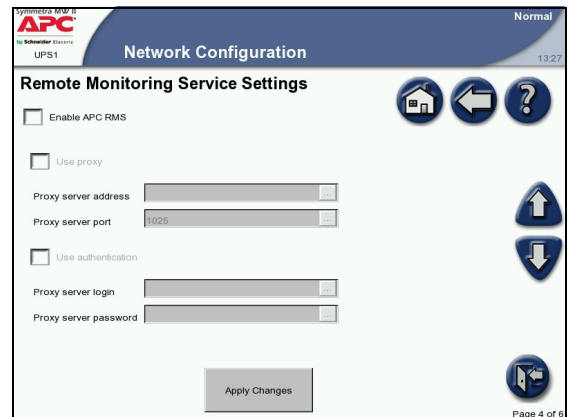

The screenshot shows the 'Network Configuration' page for an APC UPS1. The 'Remote Monitoring Service Settings' section includes the following options and fields:

- Enable APC RMS
- Use proxy
- Proxy server address: [Text Input Field]
- Proxy server port: [Text Input Field with value 1625]
- Use authentication
- Proxy server login: [Text Input Field]
- Proxy server password: [Text Input Field]

An 'Apply Changes' button is located at the bottom of the settings section. The page also features navigation icons (home, back, forward, search) and a 'Page 4 of 6' indicator.



Note: The APC Remote Monitoring Service (RMS) will not be activated until the RMS Team has been contacted. The contact details can be found at <http://rms.apc.com>.

- Enable APC RMS: Select this checkbox to start using the service. Once selected, information about your UPS will periodically be sent to APC's Remote Monitoring Service.
- Use Proxy: Select this checkbox if the Internet connection method uses a HTTP proxy server to connect to the Internet.
- Proxy server address: Enter the fully qualified IP-address or fully qualified domain name of the proxy server. If you do not know the server address or port number, contact your network administrator.
- Proxy server port: Enter the port number of the proxy server.
- Use authentication: Select this checkbox if the proxy server requires a login. Then specify a Proxy server login (user name) and a Proxy server password.
- Press **Apply Changes** to complete the changes and select arrow down to go to the next Network Configuration screen.

6. Configure the APC ISX Settings screen:

- Enable ISX discovery: Press the field to enable the APC ISX Manager or ISX Central to discover your Symmetra MW II.
- Read/Write Community name: Specify a valid community name. This is automatically set to public. It must match the name set on the ISX device in order to allow discovery.
- System name (optional).
- System location (optional).
- System contact (optional).
- FTP User name. It must match the user name set on the ISX device in order to allow discovery.
- FTP Password. It must match the password set on the ISX device in order to allow discovery.
- Press **Apply Changes** to complete the changes.

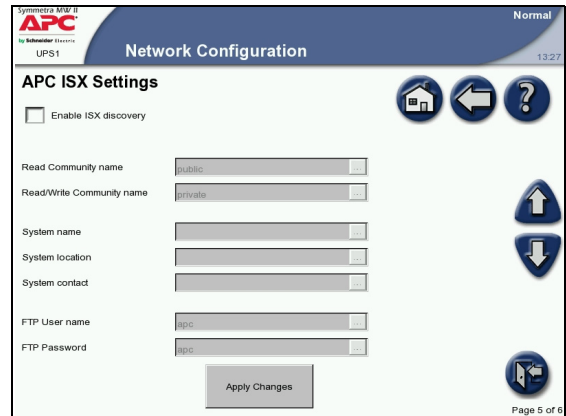

7. Configure the Remote Display Settings screen:

- Enable Remote Display: Select this checkbox to enable remote display sessions.
- Remote Display Inactivity Time-out: Specify the desired time-out period for the remote display settings (5, 10, 15, 30 minutes or never). If never is selected, the remote display session will not time-out automatically but must be manually disconnected.
- Press **Apply Changes** to complete the changes.

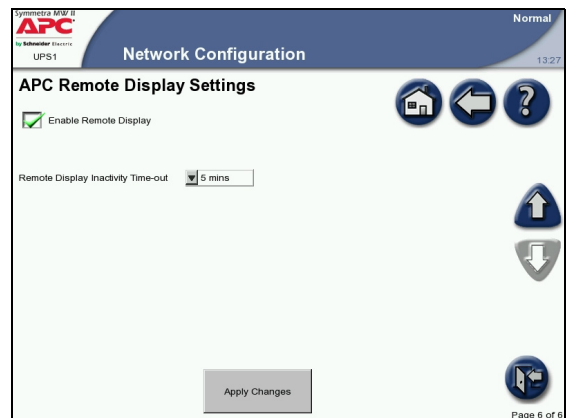

How to configure the Display Settings

1. Press the **Display Settings** button on the User Configuration screen to access the Display Settings screen.

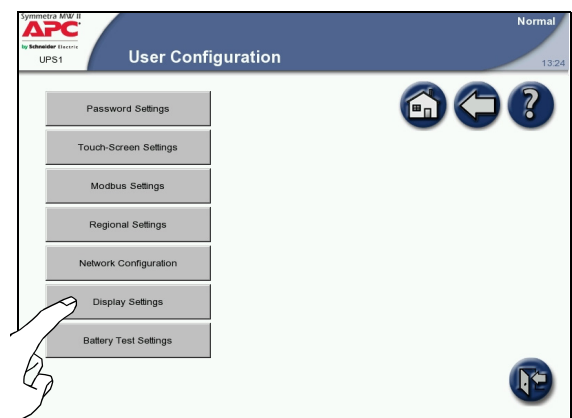

2. Change the display settings:
 - Enable APC Q breaker prefix: Use this checkbox to enable or disable the APC Q breaker prefix.
 - Enable audible alarms: Use this checkbox to enable or disable the audible alarms.

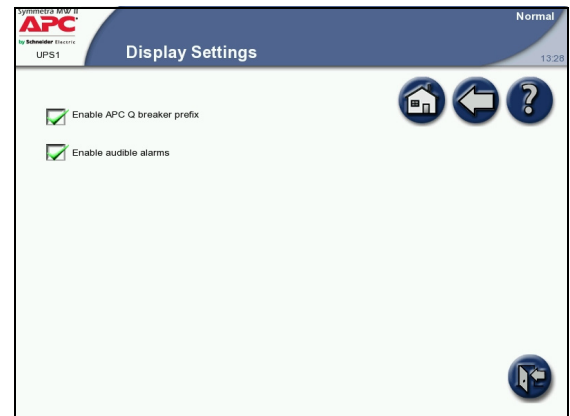

How to configure the Battery Test Settings screen

1. Press the **Battery Test Settings** button on the User Configuration screen to access the Display Settings screen.

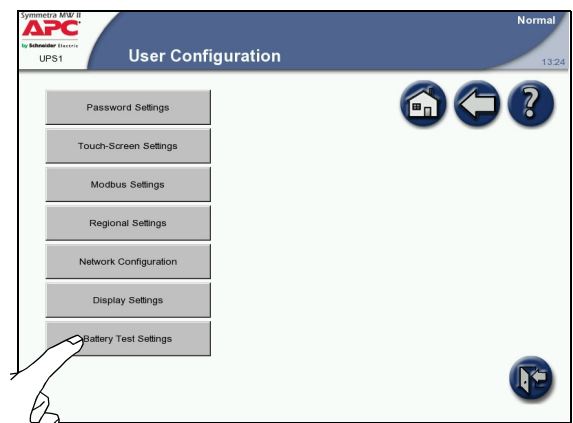

2. Change the battery test settings. From the Battery Test Settings screen, two different battery tests can be performed and the battery monitor can be reset.
 - Battery monitor test: Setting this value to True results in an automatic battery monitor test occurring dependant in the battery test options configured by the service engineer.
 - Battery capacity test: Setting this value to True results in the batteries being discharged until a Battery Low Voltage Level is reached. This test can only be performed manually. The test is used to cycle the batteries in order to calibrate the backup time with the current load and battery modules installed.
 - Battery monitor reset: In the event of a weak battery or another battery problem, use this button to reset the battery monitor.

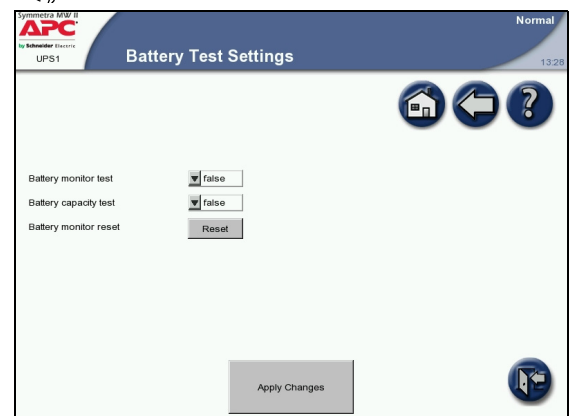

Maintenance

Predictive Maintenance Screens

The Predictive Maintenance screens display the stress status and the Expected Remaining Lifetime (ERL) of the critical components of the Symmetra MW UPS system.



Warning: Only personnel trained in the construction and operation of the equipment, and the electrical and mechanical hazards involved, may install or remove system components.

How to access the Predictive Maintenance screens

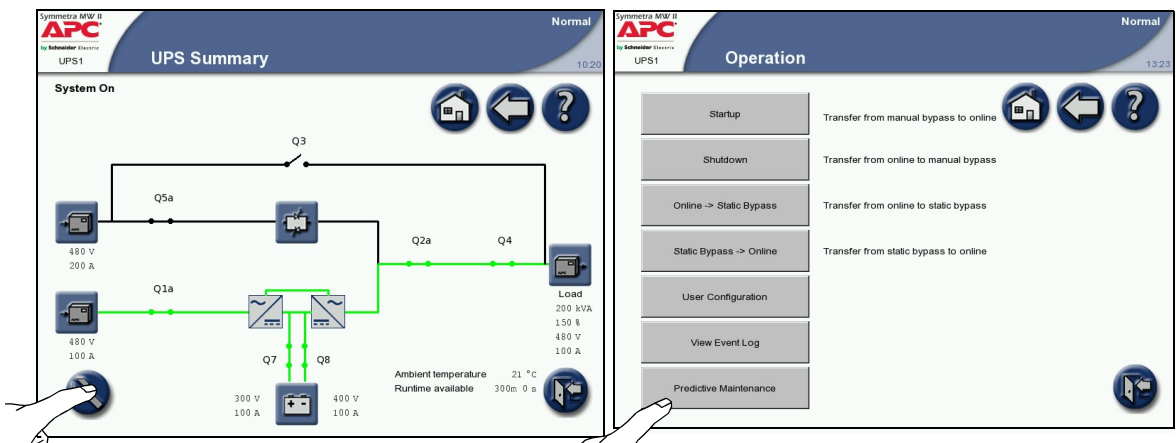

1 Press the **Operation** button in the bottom left corner to access the Operation screen.

2 Press the **Predictive Maintenance** button to access the Predictive Maintenance screens.

Inverter DC Capacitors screen

The Inverter DC Capacitor screen displays the actual status and Expected Remaining Lifetime (ERL) of the Inverter DC Capacitors. You can sort the data by pressing any of the column labels.

- Stress Status: Shows the actual status of the Inverter DC Capacitors. The possible values are:
 - Normal (displayed in green)
 - Stressed (displayed in yellow)
 - Major Stress (displayed in red)
- ERL (months): Predicts the expected remaining lifetime of the particular component.

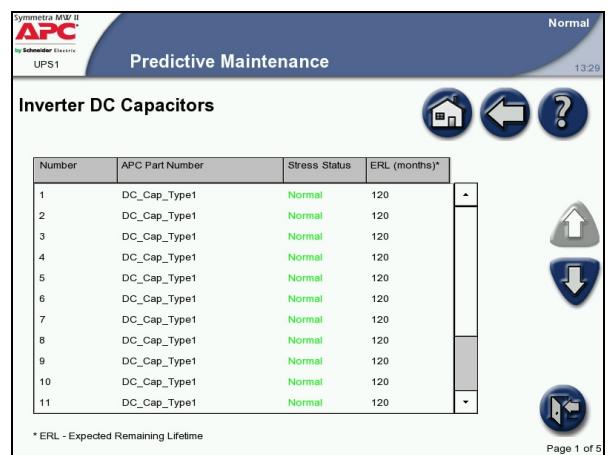

Inverter AC Capacitors screen

The Inverter AC Capacitor screen displays the actual status and Expected Remaining Lifetime (ERL) of the Inverter AC Capacitors. You can sort the data by pressing any of the column labels.

- Stress Status: Shows the actual status of the Inverter AC Capacitors. The possible values are:
 - Normal (displayed in green)
 - Stressed (displayed in yellow)
 - Major Stress (displayed in red)
- ERL (months): Predicts the expected remaining lifetime of the particular component.

Number	APC Part Number	Stress Status	ERL (months)*
1	AC_Cap_Type1	Normal	120
2	AC_Cap_Type1	Normal	120
3	AC_Cap_Type1	Normal	120
4	AC_Cap_Type1	Normal	120
5	AC_Cap_Type1	Normal	120
6	AC_Cap_Type1	Normal	120
7	AC_Cap_Type1	Normal	120
8	AC_Cap_Type1	Normal	120
9	AC_Cap_Type1	Normal	120
10	AC_Cap_Type1	Normal	120
11	AC_Cap_Type1	Normal	120

* ERL - Expected Remaining Lifetime

Top Fans screen

The Top Fans screen displays the actual status and Expected Remaining Lifetime (ERL) of the Top Fans. You can sort the data by touching any of the column labels.

- Stress Status: Shows the actual status of the Top Fans. The possible values are:
 - Normal (displayed in green)
 - Stressed (displayed in yellow)
 - Major Stress (displayed in red)
- ERL (months): Predicts the expected remaining lifetime of the particular component.

Number	APC Part Number	Stress Status	ERL (months)*
1	Fan_Type2	Normal	120
2	Fan_Type2	Normal	120
3	Fan_Type2	Normal	120
4	Fan_Type2	Normal	120
5	Fan_Type2	Normal	120
6	Fan_Type2	Normal	120
7	Fan_Type2	Normal	120
8	Fan_Type2	Normal	120
9	Fan_Type2	Normal	120
10	Fan_Type2	Normal	120
11	Fan_Type2	Normal	120

* ERL - Expected Remaining Lifetime

Inverter Fans screen

The Inverter Fans screen displays the actual status and Expected Remaining Lifetime (ERL) of the Inverter Fans. You can sort the data by pressing any of the column labels.

- Stress Status: Shows the actual status of the Inverter Fans. The possible values are:
 - Normal (displayed in green)
 - Stressed (displayed in yellow)
 - Major Stress (displayed in red)
- ERL (months): Predicts the expected remaining lifetime of the particular component.

Number	APC Part Number	Stress Status	ERL (months)*
1	Fan_Type1	Normal	120
2	Fan_Type1	Normal	120
3	Fan_Type1	Normal	120
4	Fan_Type1	Normal	120
5	Fan_Type1	Normal	120
6	Fan_Type1	Normal	120
7	Fan_Type1	Normal	120
8	Fan_Type1	Normal	120
9	Fan_Type1	Normal	120
10	Fan_Type1	Normal	120
11	Fan_Type1	Normal	120

Main Static Switch Fans screen

The Main Static Switch Fans screen displays the actual status and Expected Remaining Lifetime (ERL) of the Main Static Switch Fans. You can sort the data by pressing any of the column labels.

- Stress Status: Shows the actual status of the Main Static Switch Fans. The possible values are:
 - Normal (displayed in green)
 - Stressed (displayed in yellow)
 - Major Stress (displayed in red)
- ERL (months): Predicts the expected remaining lifetime of the particular component.

Number	APC Part Number	Stress Status	ERL (months)*
1	Fan_Type3	Normal	120
2	Fan_Type3	Normal	120
3	Fan_Type3	Normal	120
4	Fan_Type3	Normal	120
5	Fan_Type3	Normal	120
6	Fan_Type3	Normal	120

How to Change the Air Filters

Check the air filters at regular intervals (every three months under normal working conditions) for accumulated dust on the surface facing the finishing panels. Change all filters at the same time.

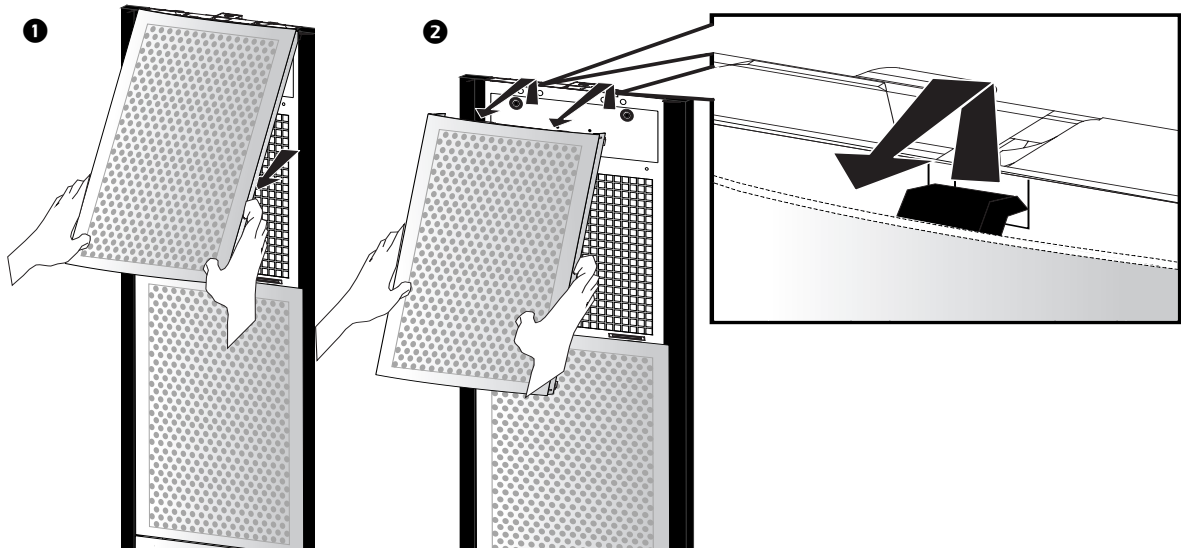

1. Pull the lower part of the top finishing panel off the UPS.
2. Lift the finishing panel off the dead front panel and remove.
3. Follow this procedure until all panels in one column have been removed. Use the same procedure for the next column of panels until all panels have been removed from the UPS system.

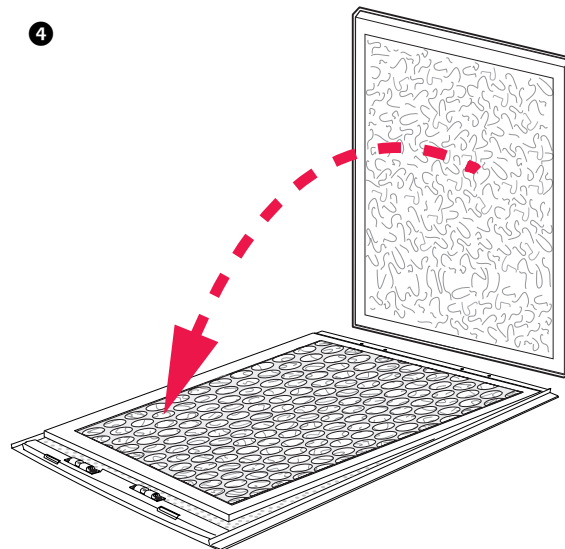

Note: Note the orientation of the air filter.

4. Remove the air filters and install new filters.
5. Re-install the finishing panels in reverse order.

Troubleshooting

Alarm Types

The color of the top of the screen switches from blue to red when an alarm situation occurs and the alarm symbol is shown at the top of the screen.



Pressing the alarm button will display the Active Alarms screen showing all active alarms, along with a methodology for addressing each alarm. Pressing the alarm button or any other display button will automatically silence the alarm.

Info

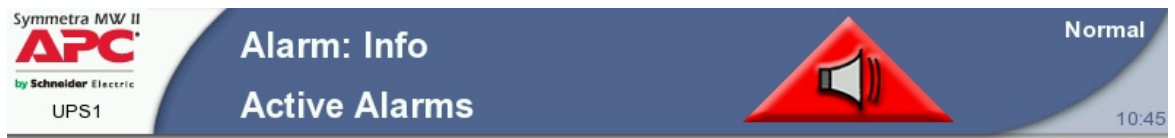

Informational Alarm. No immediate need to take action. Check the cause of the alarm at next maintenance visit.

Warning



Warning Alarm. Example: The UPS system may have gone into bypass. The load remains supported, but action must be taken. Call Technical Support. The area in the right side of the top screen alternates between blue and red.

Severe



Severe Alarm. Take immediate action. Call Technical Support. The red area of the top of the screen alternates between blue and red.

How to silence the alarm

Press the alarm button or any other display button to silence the alarm.

How to view active alarms

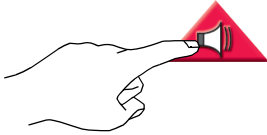

Severity	Alarm Description	Suggested Action	Date & Time
Warning	Replace DC capacitor bank	Call APC for service	04-21-2004 11:00:54.0
Warning	Replace AC capacitor bank	Call APC for service	04-21-2004 11:00:54.0
Warning	Relay board CAN I/O fault	Call APC for service	04-21-2004 11:00:54.0
Warning	DC capacitor temperature high	Call APC for service	04-21-2004 11:00:54.0
Warning	AC output capacitor temperature high	Call APC for service	04-21-2004 11:00:54.0
Warning	AC input capacitor temperature high	Call APC for service	04-21-2004 11:00:54.0
Warning	Power module communication fault	Call APC for service	04-21-2004 11:00:54.0
Warning	Main inverter current sense fault	Call APC for service	04-21-2004 11:00:54.0
Warning	Power module power supply unit fault	Call APC for service	04-21-2004 11:00:54.0
Warning	Main controller SELV power supply fault	Call APC for service	04-21-2004 11:00:54.0
Warning	Main power supply unit fault	Call APC for service	04-21-2004 11:00:54.0
Warning	Delta inverter peak current limiter on	Remove load from the UPS	04-21-2004 11:00:54.0
Warning	Main inverter peak current limiter on	Remove load from the UPS	04-21-2004 11:00:54.0
Warning	Replace top fan	Call APC for service	04-21-2004 11:00:54.0

1. Press the red triangular alarm symbol to view active alarms.

2. Only active alarms will appear in this list. Previous alarms are stored in the Event Log, which contains a detailed record of the system's last 1024 events. Press the **Event Log** button to go to the Event Log.



Note: The Active Alarms screen includes a recommended action for resolving each problem.

How to view the event log

The event log can be accessed either by pressing the Event Log button on the Active Alarms screen or by following this procedure:

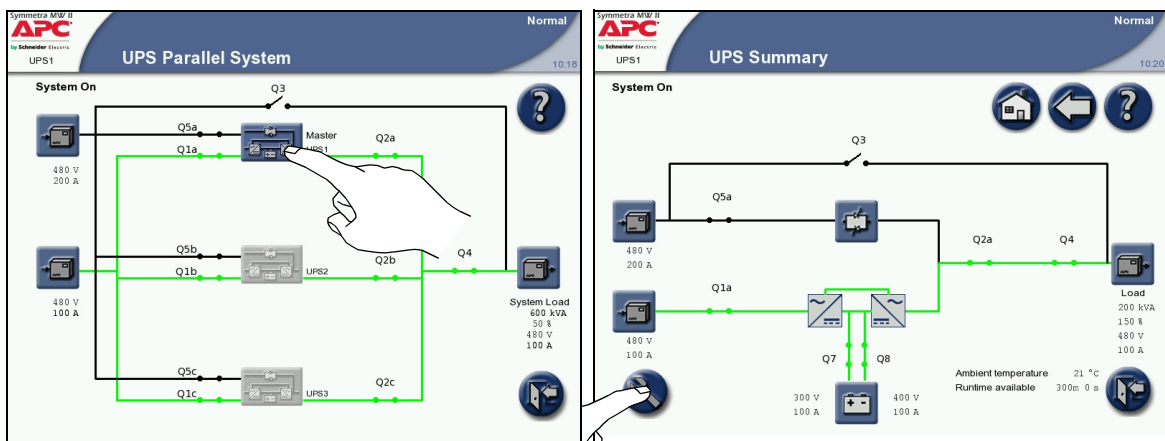

1. Press the highlighted UPS.

2. Press the **Operation** button.

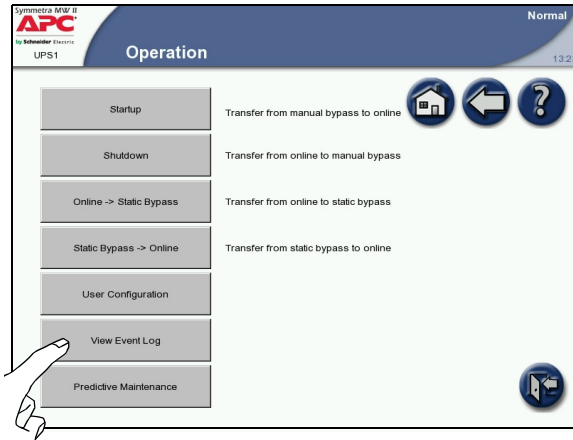

3. Press the **View Event Log** button to access the Event Log screen.

The Event Log screen contains a detailed record of the system's latest 1024 events. This includes operation mode changes, system alarms, etc.

The Param (Parameter) column is used to associate an event with a specific component. Should there be data relevant to a particular event, it will be displayed in the Data column e.g. if a temperature threshold was exceeded, the actual temperature at the time the event occurred may be shown.

- Refresh: Press the Refresh button to update the Event Log.
- Stop (only visible during update): Press this button to stop further downloading of the event log. This button is useful for viewing only the most recent events.
- E-mail Event Log: Press this button to e-mail the event log to a specific e-mail address. Type in the e-mail address and press **Send**.

Severity	Alarm Description	Suggested Action	Date & Time
Warning	Replace DC capacitor bank	Call APC for service	04-21-2004 11:00:54.0
Warning	Replace AC capacitor bank	Call APC for service	04-21-2004 11:00:54.0
Warning	Relay board CAN I/O fault	Call APC for service	04-21-2004 11:00:54.0
Warning	DC capacitor temperature high	Call APC for service	04-21-2004 11:00:54.0
Warning	AC output capacitor temperature high	Call APC for service	04-21-2004 11:00:54.0
Warning	AC input capacitor temperature high	Call APC for service	04-21-2004 11:00:54.0
Warning	Power module communication fault	Call APC for service	04-21-2004 11:00:54.0
Warning	Main inverter current sense fault	Call APC for service	04-21-2004 11:00:54.0
Warning	Power module power supply unit fault	Call APC for service	04-21-2004 11:00:54.0
Warning	Main controller SELV power supply fault	Call APC for service	04-21-2004 11:00:54.0
Warning	Main power supply unit fault	Call APC for service	04-21-2004 11:00:54.0
Warning	Delta inverter peak current limiter on	Remove load from the UPS	04-21-2004 11:00:54.0
Warning	Main inverter peak current limiter on	Remove load from the UPS	04-21-2004 11:00:54.0
Warning	Replace top fan	Call APC for service	04-21-2004 11:00:54.0



Note: Network settings and E-mail settings must be enabled and configured correctly before the event log can be e-mailed.

APC Worldwide Customer Support

Customer support for this or any other APC product is available at no charge in any of the following ways:

- Visit the APC Web site to access documents in the APC Knowledge Base and to submit customer support requests.
 - **www.apc.com** (Corporate Headquarters)
Connect to localized APC Web sites for specific countries, each of which provides customer support information.
 - **www.apc.com/support/**
Global support searching APC Knowledge Base and using e-support.
- Contact the APC Customer Support Center by telephone or e-mail.
 - Local, country-specific centers: go to **www.apc.com/support/contact** for contact information.

For information on how to obtain local customer support, contact the APC representative or other distributors from whom you purchased your APC product.

Entire contents copyright 2009 American Power Conversion Corporation. All rights reserved. Reproduction in whole or in part without permission is prohibited. APC, the APC logo, and Symmetra are trademarks of American Power Conversion Corporation. All other trademarks, product names, and corporate names are the property of their respective owners and are used for informational purposes only.



990-1757B-001



3/2009