

Installation Manual

Uniflair™ LE

Uniflair™ LE Chilled Water Air Conditioners

TDCV, TUCV

990-4484B-001

Publication Date: August 2016



Schneider Electric IT Corporation Legal Disclaimer

The information presented in this manual is not warranted by the Schneider Electric IT Corporation to be authoritative, error free, or complete. This publication is not meant to be a substitute for a detailed operational and site specific development plan. Therefore, Schneider Electric IT Corporation assumes no liability for damages, violations of codes, improper installation, system failures, or any other problems that could arise based on the use of this Publication.

The information contained in this Publication is provided as is and has been prepared solely for the purpose of evaluating data center design and construction. This Publication has been compiled in good faith by Schneider Electric IT Corporation. However, no representation is made or warranty given, either express or implied, as to the completeness or accuracy of the information this Publication contains.

IN NO EVENT SHALL SCHNEIDER ELECTRIC IT CORPORATION, OR ANY PARENT, AFFILIATE OR SUBSIDIARY COMPANY OF SCHNEIDER ELECTRIC IT CORPORATION OR THEIR RESPECTIVE OFFICERS, DIRECTORS, OR EMPLOYEES BE LIABLE FOR ANY DIRECT, INDIRECT, CONSEQUENTIAL, PUNITIVE, SPECIAL, OR INCIDENTAL DAMAGES (INCLUDING, WITHOUT LIMITATION, DAMAGES FOR LOSS OF BUSINESS, CONTRACT, REVENUE, DATA, INFORMATION, OR BUSINESS INTERRUPTION) RESULTING FROM, ARISING OUT, OR IN CONNECTION WITH THE USE OF, OR INABILITY TO USE THIS PUBLICATION OR THE CONTENT, EVEN IF SCHNEIDER ELECTRIC IT CORPORATION HAS BEEN EXPRESSLY ADVISED OF THE POSSIBILITY OF SUCH DAMAGES. SCHNEIDER ELECTRIC IT CORPORATION RESERVES THE RIGHT TO MAKE CHANGES OR UPDATES WITH RESPECT TO OR IN THE CONTENT OF THE PUBLICATION OR THE FORMAT THEREOF AT ANY TIME WITHOUT NOTICE.

Copyright, intellectual, and all other proprietary rights in the content (including but not limited to software, audio, video, text, and photographs) rests with Schneider Electric IT Corporation or its licensors. All rights in the content not expressly granted herein are reserved. No rights of any kind are licensed or assigned or shall otherwise pass to persons accessing this information.

This Publication shall not be for resale in whole or in part.

Table of Contents

Safety.....	1
Important Safety Information	1
Safety Guidelines During Installation	2
Symbols on Unit or Packaging	2
Electrical Safety	4
Warning for Lifting and Transportation	5
Warning for Installation	6
Intended Use	6
General Information.....	7
Document Overview	7
Cross-reference symbol used in this manual	7
Abbreviations	7
Receiving and Inspecting the Cooling unit	7
Storing the Cooling Unit Before Installation	7
Equipment Disposal	8
Waste Electrical and Electronic Equipment (WEEE) disposal ..	8
Equipment Guidelines.....	9
Working Conditions and Environmental Limits	9
Glycol mixtures	9
Unit Overview	10
Model Nomenclature	10
Nameplate	11
Airflow Configurations	12
Upflow	12
Downflow	12

Operating Description 13

Component Identification 14

 Unit Components 14

 Display Interface 15

 Electrical Panel 16

Installation 17

 Site Preparation 17

 Access and clearance requirements 17

 Power supply requirements 18

 Humidifier and drain requirements 18

 Installation types 18

 Power supply requirements 18

 Humidifier and drain requirements 19

 Installation on Floor Stand 19

 Installation on Sub-Base 20

 Opening the Door and Removing the Front Panels 21

 Main disconnect switch 21

 Opening the door 22

 Removal 22

 Internal Protection and Rear Panels 23

 Removal 23

Unit Connections 24

 Electrical Connections 24

 Connecting power to the unit 24

 Setting the unit power supply voltage 25

 Drain Connections 26

 Connecting to building drains (without humidifier) 26

 Water Piping Connections 27

 Filling the chilled water circuit 28

 Access to bleed valves 29

 Manual Start Up and Shut Down 30

 Starting the unit 30

Turn Off the Unit	30
-----------------------------	----

Settings and Adjustments 31

Selecting the Fan Output Percentage	31
---	----

Units Without Electrical Heaters	32
--	----

Units With Electrical Heaters	34
---	----

Setting the Regulation and Safety Devices	36
---	----

Setting the Air Flow Sensor	37
---------------------------------------	----

Setting the Clogged Filter Sensors	38
--	----

Accessories 39

Humidifier	39
----------------------	----

Components	39
----------------------	----

Humidifier connections	40
----------------------------------	----

Connecting to the drainage and water supply lines	40
---	----

Supply water	41
------------------------	----

Electrical Heaters	42
------------------------------	----

Electrical heaters capacity with 230V/3pH/60Hz power supply	42
---	----

Electrical heaters capacity with 208V/3pH/60Hz power supply	42
---	----

Electrical heaters capacity with 460V/3pH/60Hz power supply	42
---	----

Temperature and Humidity Sensor	43
---	----

Installation	43
------------------------	----

Discharge Temperature Threshold Sensor	43
--	----

Safety

Important Safety Information

Read the instructions carefully to become familiar with the equipment before trying to install, operate, service, or maintain it. The following special messages may appear throughout this manual or on the equipment to warn of potential hazards or to call attention to information that clarifies or simplifies a procedure.



The addition of this symbol to a Danger or Warning safety label indicates that an electrical hazard exists which will result in personal injury if the instructions are not followed.



This is the safety alert symbol. It is used to alert you to potential personal injury hazards. Obey all safety messages that follow this symbol to avoid possible injury or death.

⚠ DANGER

DANGER indicates an imminently hazardous situation which, if not avoided, **will result in** death or serious injury.

⚠ WARNING

WARNING indicates a potentially hazardous situation which, if not avoided, **can result in** death or serious injury.

⚠ CAUTION

CAUTION indicates a potentially hazardous situation which, if not avoided, **can result in** minor or moderate injury.

NOTICE

NOTICE addresses practices not related to physical injury including certain environmental hazards, potential damage or loss of data.

Safety Guidelines During Installation

⚠ WARNING
VIOLATION OF SAFETY STANDARDS
Removal of or tampering with safety devices is a violation of safety standards and will void all warranties.
Failure to follow these instructions can result in death, serious injury, or equipment damage.









⚠ WARNING
PERSONAL PROTECTIVE EQUIPMENT REQUIRED
During installation authorized personnel must wear approved personal protective equipment (PPE).
Failure to follow these instructions can result in death, serious injury, or equipment damage.

Carefully read this manual before performing any maintenance or work on the units. Installation, maintenance, and usage must meet all work safety standards. The operator responsible for the mentioned services must possess expert knowledge of the devices. Schneider Electric refuses all responsibility for damage resulting from the failure to follow safety standards.

Schneider Electric will only consider itself responsible for the safety, reliability, and performance of the unit if

- Maintenance and servicing work have only been carried out by authorized personnel.
- The appliance shall be installed in accordance with applicable industry guidelines and national and local codes and regulations.
- Devices are used in conformity with the appropriate instructions.

Symbols on Unit or Packaging

Symbol	Meaning	Symbol	Meaning
	Danger		Moving parts
	Important notice		Sharp surfaces
	High voltage: Risk of electric shock		This side up: Shows the correct orientation of the packed unit
	Fragile: Handle with care		Temperature limits: The packed unit must be stored in a place within the indicated the indicated temperature limits.



Keep dry: The packed unit must be stored in a dry place.



Center of gravity: Shows the center of gravity of the packed unit.



Keep away from heat: The unit must be stored away from heat sources.





Do not use hooks: Do not list the packed unit with hooks.





Do not stack: The packed units must not be stacked.

Electrical Safety

Read and adhere to the following important safety considerations when working with this cooling unit.

  DANGER
HAZARD OF ELECTRIC SHOCK, EXPLOSION, OR ARC FLASH
<ul style="list-style-type: none">• Apply appropriate personal protective equipment (PPE) and follow safe electrical work practices.• This equipment must be installed and serviced by qualified personnel only.• Turn off all power supplying this equipment before working on or inside the equipment.• Always use a properly rated voltage sensing device to confirm power is off.• Replace all devices, doors, and covers before turning on power to this equipment.• If the power supply cord is damaged, it must be replaced by an equivalent cord or assembly available from the manufacturer or its service agent.
Failure to follow these instructions will result in death or serious injury.

  DANGER
HAZARD OF ELECTRIC SHOCK, EXPLOSION, OR ARC FLASH
Turn off all power supplying this equipment before working on the equipment. All electrical work must be performed by qualified personnel. Practice Lockout/Tagout procedures. Do not wear jewelry when working with electrical equipment.
Failure to follow these instructions will result in death or serious injury.

Warning for Lifting and Transportation

Lifting and transporting the units must be carried out by qualified personnel as described in this manual.

⚠ CAUTION
DAMAGE TO EQUIPMENT OR PERSONNEL
<ul style="list-style-type: none">• The equipment is heavy and can easily be tipped. For safety purposes, adequate personnel must be present when moving this equipment.• The load must always be solidly anchored to the bearing element of the lifting equipment and means of transport.• No one should be near the suspended load, nor in the working area of the crane, forklift, truck, or any other lifting equipment or means of transport.
Failure to follow these instructions can result in moderate injury or equipment damage.

Use all relevant safety standards to prevent any possible damage to people or objects.

The cooling unit packaged in a wooden crate or anchored to a pallet and covered with transparent film. The recommended tools for moving and installing the equipment include the following:

FORKLIFT



PALLET JACK



SLING



The following graphic provides an example of equipment used to move the unit safely.

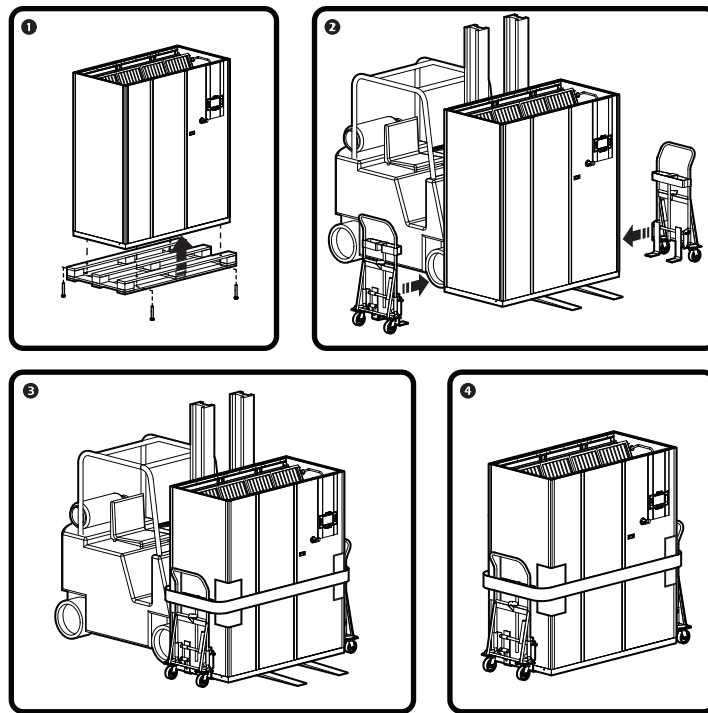

Warning for Installation

All electrical and mechanical installations must be carried out by qualified personnel only. Qualified personnel must use appropriate equipment when checking the grounding of devices. Installation locations should be secure and limited to site authorized personnel or trained service technicians.

⚠ WARNING

HAZARD FROM MOVING PARTS

Keep hands, clothing, and jewelry away from moving parts. Check the equipment for foreign objects before closing the doors and starting the equipment.

Failure to follow these instructions can result in death, serious injury, or equipment damage.

Intended Use

The cooling units provide air conditioning within the limits and methods described in this manual. The air conditioners must be used exclusively indoors. No modifications may be made to the units or their parts without explicit written consent from Schneider Electric. Any mechanical or electrical modification voids factory warranty.

General Information

Document Overview

The Uniflair™ Chilled Water cooling unit is a precision air conditioner used to control environments for telecom rooms, Internet hubs, and data processing centers.

This manual describes the cooling units with 208-/230-V/ 3-phase/ 60-Hz and 460-V/ 3-phase/ 60-Hz power supply. It supplies general information, safety instructions, unit transportation, installation information, and necessary information on how to install the units.

The descriptions and illustrations in this manual are owned by Schneider Electric. Schneider Electric reserves the right to make any alterations it sees fit in order to improve the product without having to update this document.

The illustrations in this manual are examples only and may differ from your situation. All component locations depend on model type and configuration.

Cross-reference symbol used in this manual



See another section of this document or another document for more information on this subject.

Abbreviations

T*CV—Chilled water cooling units

*U = Upflow; D = Downflow

Receiving and Inspecting the Cooling unit

The cooling unit is packaged in a wooden crate or anchored to a pallet and covered with transparent film.

Upon delivery, check to make sure the unit is intact and immediately notify the carrier in writing of any damage that can be attributed to careless or improper transportation. Check for any damage on the area upon which the display interface is mounted.

In case of shipping damage, do not operate the cooling unit. Keep all packaging for inspection used by the shipping company and contact Schneider Electric Corporation.

Storing the Cooling Unit Before Installation

NOTICE

WEATHER DAMAGE

Leaving the cooling unit uncovered and exposed to possible damage from the environment will void the factory warranty.

Failure to follow these instructions can result in equipment damage.

If storing the unit for a period of time, the following procedures must be followed:

- The storage area must be dry (<85% R.H.) and protected against minimum storage temperatures -20°C (-4°F) and extreme storage temperatures 50°C (122°F).
- The unit should remain in its original packaging if stored for long periods of time.

Equipment Disposal

Waste Electrical and Electronic Equipment (WEEE) disposal



Schneider Electric products comply with international directives on the Restriction of Hazardous Substances (RoHS) in electronic and electrical equipment and the disposal of Waste Electrical and Electronic Equipment (WEEE). Dispose of any waste electronic or electrical equipment with the appropriate recycling center. Contact Schneider Electric for assistance.

Equipment Guidelines

Working Conditions and Environmental Limits

Hot Water Circuit	
Maximum inlet hot water temperature	77°C (170°F)
Minimum inlet hot water temperature	45°C (113°F)
Maximum operating pressure hot water circuit	150 psi
Cold Water Circuit	
Maximum inlet cold water temperature	25°C (77°F)
Minimum inlet cold water temperature	6°C (42°F)
Maximum glycol percentage	50%
Maximum operating pressure cold water circuit	150 psi
Air	
Maximum inlet air temperature	35°C (96°F)
Minimum inlet air temperature	18°C (64°F)
Maximum inlet relative humidity	70%
Minimum inlet air relative humidity	30%
Maximum inlet dew point	15°C (59°F)
Storage Conditions	
Temperature	<50°C (122°F)
Humidity	<85% R.H.

Glycol mixtures

The Uniflair™ LE Chilled Water cooling units are able to operate with both pure water and glycol mixtures. Glycol mixtures with water ethylene glycol or propylene glycol may not exceed 50% volume. Note any environmental limitations regarding its use.

NOTE: Contact Schneider Electric for applications that are outside of the documented specifications.

Unit Overview

Model Nomenclature

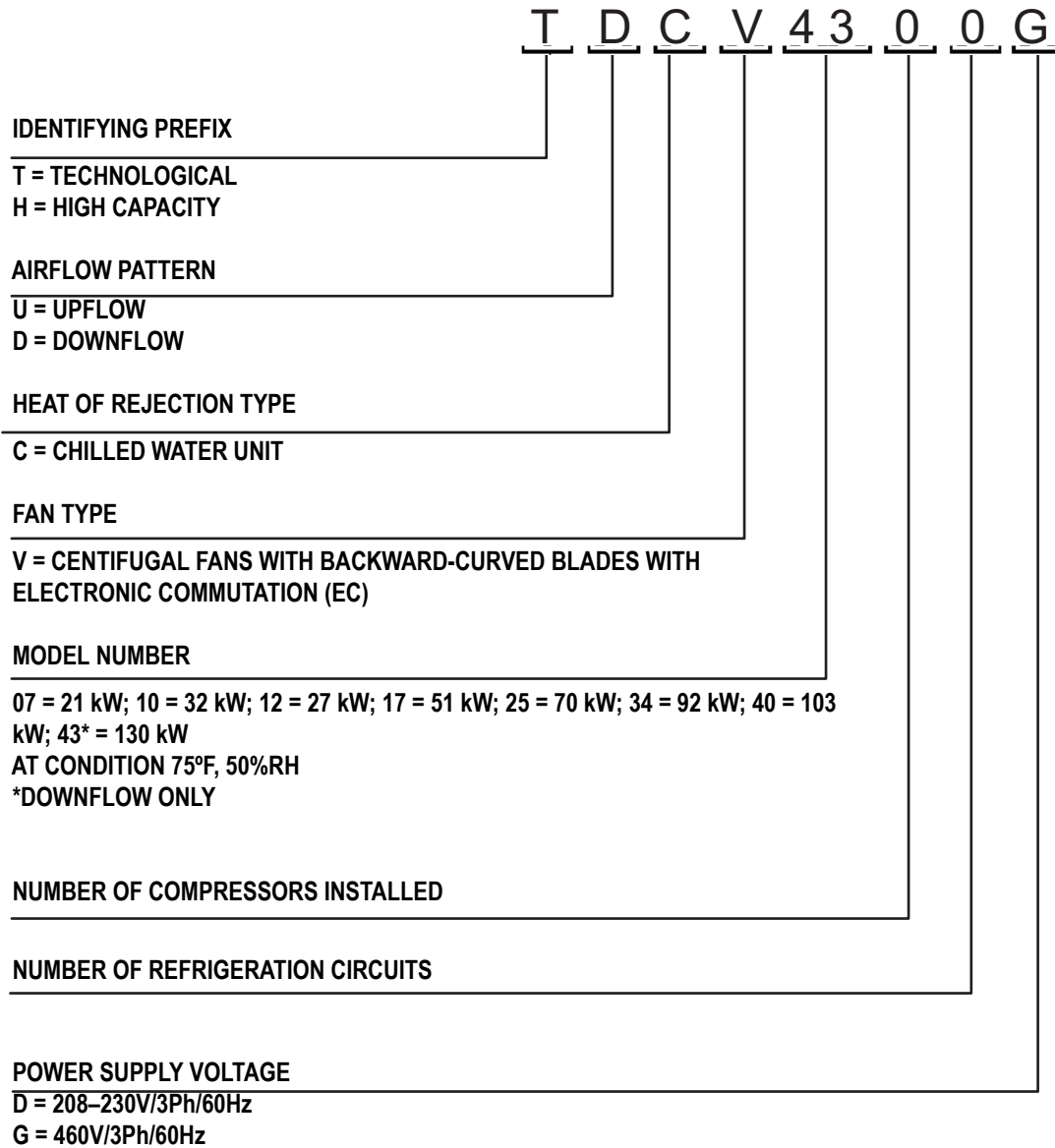

na3791b

Nameplate

The units can be identified by the name plate which is placed in the electrical panel of the unit. The model and any additional accessories which are installed are indicated by an “X” in the corresponding box.

The nameplate provides the following data:

- Model and serial number
- Type of power supply
- Overall electrical rating
- Individual load electrical ratings
- Full load amps (FLA)
- Minimum circuit ampacity (MCA)
- Maximum overcurrent protection (MOP)
- Maximum inlet hot water temperature (if present)
- Maximum fan static pressure at max fan speed (ESP MAX)



TDCV0700D(D)						SERIAL No. UCV 100658	
TDCV0700D(D)							
TENS.	230V/3Ph/60Hz			AUX.		24	VOLT
	NO.	TENS. (V)	OA(A) / [1]	FLA (A) / [1]	LRA (A) / [1]	P (kW/HP) [TOT]	
FAN	1	230/3	6.2	8.5		2.8/3.75	
HUMIDIFIER	1	230/3	10.4	10.4		3.93/5.27	
UNIT(*)			16.6	18.9		6.73/9.03	
MCA	23.6 A						
MOP	30 A						
ESP Max	120 Pa / 0.48 in.w.g.			(Max Fan Speed)			
Icu=15kA (CEI EN 60947-2) / (*) In operating conditions at 230V							

na4961b

Airflow Configurations

Upflow

Upflow units are designed to distribute air through a supply plenum, pre-engineered duct system, or drop ceiling. Return air can enter the unit via the front, rear, or bottom of the unit based on configuration. A sub-base is required to allow access for power, water, and refrigerant connections on non-raised floor installations.

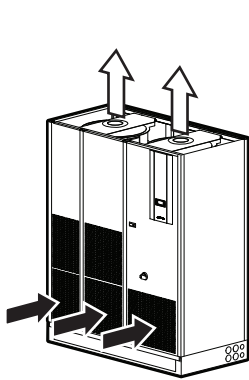

**FRONT RETURN
WITH TOP SUPPLY**

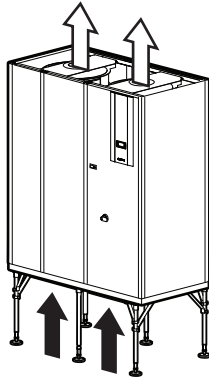

**BOTTOM RETURN
WITH TOP SUPPLY**

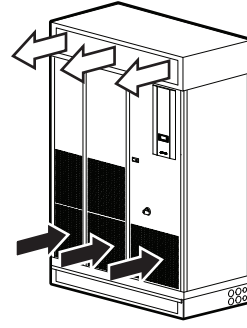

**FRONT RETURN
WITH TOP FRONT SUPPLY
(PLENUM AND GRILLE)**

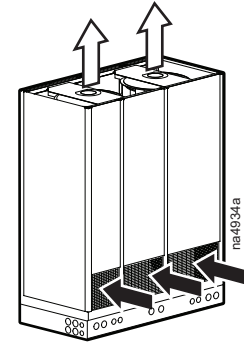

**REAR RETURN
WITH TOP SUPPLY**

Downflow

Downflow units are designed to distribute air through a front supply sub-base plenum. Return air enters the top of the unit directly from the environment or through a duct system.

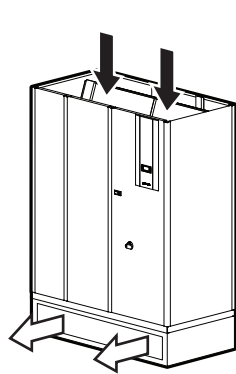

**TOP RETURN
WITH BOTTOM SUPPLY
(PLENUM AND GRILLE)**

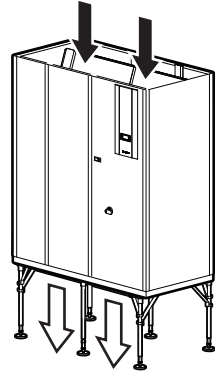

**TOP RETURN
WITH BOTTOM SUPPLY
(FLOORSTAND)**

Operating Description

This version has a relatively simple construction and simple airflow pattern through the unit to optimize performance. The microprocessor controls the actuator, which is modulating the 3-way (or optional 2-way) chilled water valve to give accurate control. Careful sizing of the evaporator coil allows a high sensible to total cooling ratio under most operating conditions.

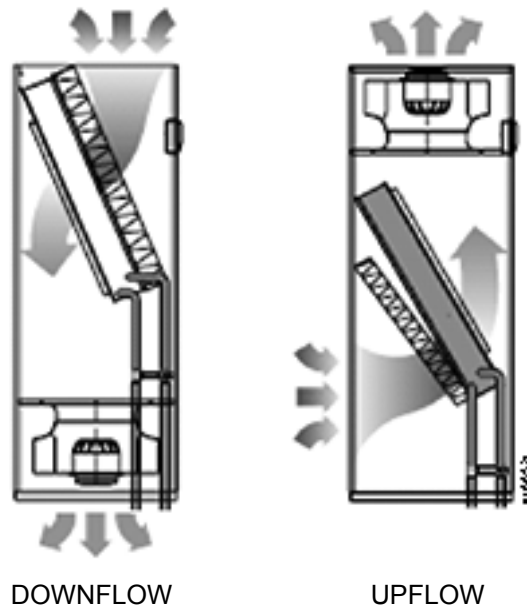

Component Identification

Unit Components

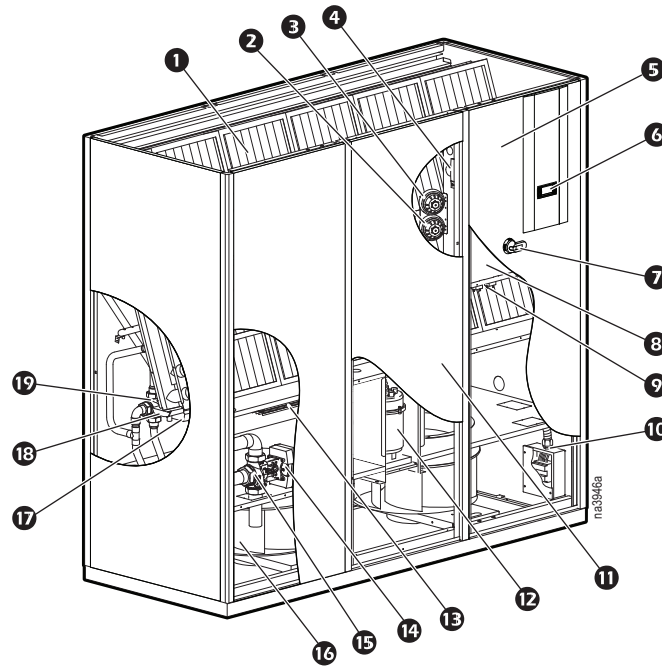

NOTE: Downflow unit shown.

Item	Description	Item	Description
1	Filters	11	Cover panel
2	Smoke sensor	12	Humidifier
3	Fire sensor	13	Electric heater
4	Temperature and humidity sensor	14	Chilled water valve actuator
5	Electrical panel door	15	2-/3-way chilled water valve
6	Display interface	16	Fans
7	Main disconnect	17	Cooling coil
8	Electrical panel	18	Condensate drain pan
9	Clogged filter pressure switch	19	Hot water reheat valve (optional)
10	Main power junction box		

Display Interface

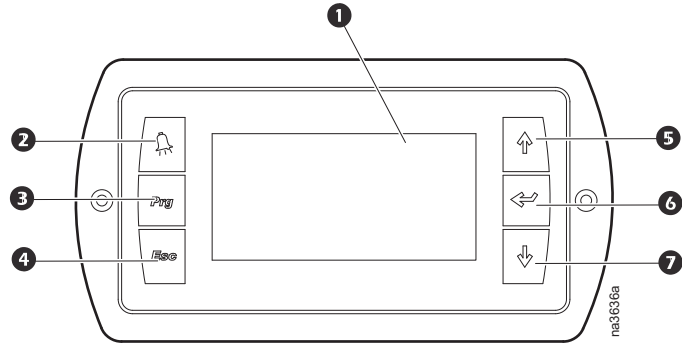

Item	Description	Function
1	LCD Display	Flat, electronic visual display
2	ALARM button	Views and resets alarms (flashes red when an alarm is activated)
3	PRG button	Enters the Configuration menu
4	ESC button	Exits the screen
5	UP button	Moves up the menu
6	ENTER button	Confirms
7	DOWN button	Moves down the menu

Electrical Panel

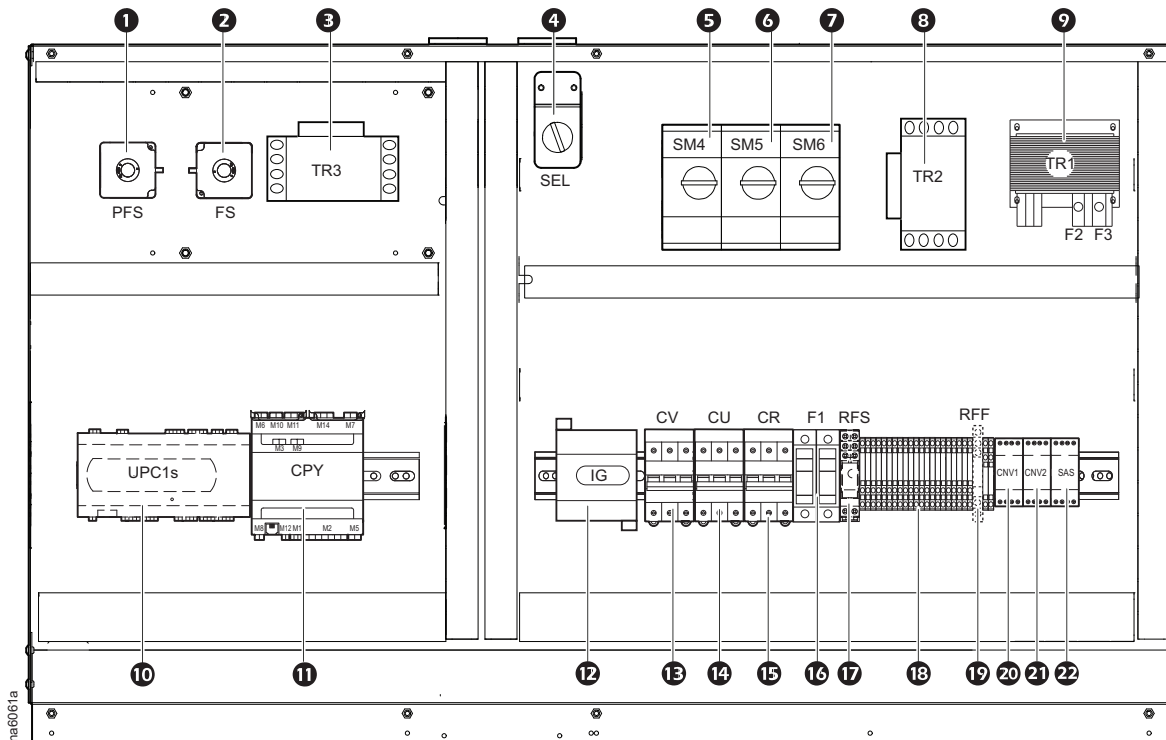

NOTE: Model 0700D shown. Locations and components will vary by unit and configuration.

Item	Description	Item	Description
1	Clogged filter pressure switch (PFS)	12	Main disconnect switch (IG)
2	Air flow pressure switch (FS)	13	Fan motor contactor (CV)
3	Transformer (TR3)	14	Humidifier contactor (CU)
4	Supply line selector—230V/208V (SEL)	15	Heating contactor (CR)
5	Fan motor overload cutout (SM4)	16	Transformer fuses (F1)
6	Humidifier overload cutout (SM5)	17	Air flow switch relay (RFS)
7	Heating overload cutout (SM6)	18	Terminal block
8	Transformer (TR2)	19	Smoke/fire relay (RFF) (optional)
9	Transformer (TR1)	20	Signal converter (CNV1)
10	pCO1 controller (UPC1s)	21	Signal converter (CNV2)
11	Humidifier controller (CPY)	22	Flooding detector (SAS) (optional)



See individual unit wiring diagrams for specific unit information.

Installation

Site Preparation

<i>NOTICE</i>
EQUIPMENT DAMAGE RISK Install the unit in an area that is protected from adverse conditions. Failure to follow these instructions can result in equipment damage.
<i>NOTICE</i>
RISK OF SPILLAGE Installing the unit on an uneven surface may result in overflow spilling from the condensate tray. Failure to follow these instructions can result in equipment damage.

Access and clearance requirements

The area of installation must follow these requirements:

- Minimum floor stand height requirement is 203.2 mm (8 in.) for downflow units.
- Front of unit must have a minimum of 700 mm (28 in.) service clearance.
- Air intake and discharge connections must not be blocked.
- Unit must be installed on a flat, level surface.

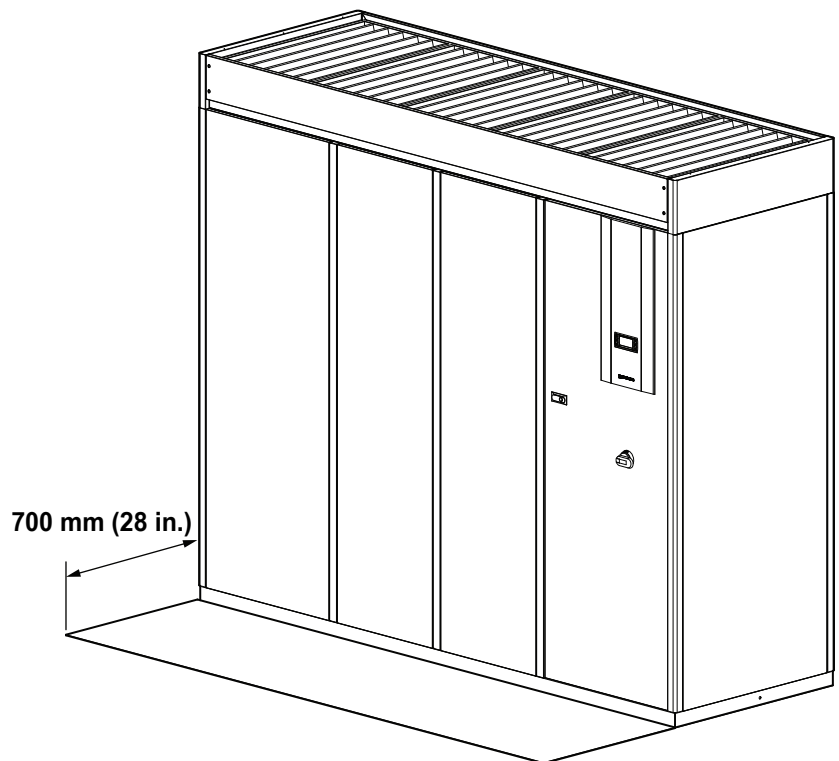

Power supply requirements

Review the electrical rating label on the equipment to determine the maximum current draw of the equipment.

⚠ WARNING
ALL EQUIPMENT MUST BE GROUNDED
<ul style="list-style-type: none">• Verify all equipment is grounded.• Electrical service must conform to national and local electrical codes and regulations.
Failure to follow these instructions can result in death, serious injury, or equipment damage.

Humidifier and drain requirements

If a humidifier is installed, the unit requires a potable cold water supply. Condensate must be removed by a gravity drain using proper P-traps, or by an optional condensate pump.



For inlet water requirements for proper operation, see “Humidifier connections” on page 40.

Installation types

Downflow units are intended for installation on raised access flooring using appropriate floor stands—or in non-raised floor environments on a provided sub-base discharge plenum supplied by Schneider Electric.

NOTE: Upflow units with air intake through the rear or front can also be installed on floors that are not raised (these systems require a sub-base or floor stand).

Installation on non-raised flooring: Installation on non-raised flooring without using floorstands is only allowable on upflow models with rear or front air return. For installations without raised floors, a sub-base is required for routing piping and electrical wiring to unit.

Installation on raised access flooring: Installation on raised access flooring requires the support of a floor stand beneath the unit. The floor stand allows installation of the unit before the raised floor is installed, increases absorption of noise and vibrations, and facilitates connection of pipes and cables. Use a vibration pad under each leg to reduce vibration.

Floor stand installation: Using the floor stand, position the unit on the mounting frame and secure it using the M8 screw inserts found on the base of the unit.

NOTE: Install a flexible seal (field supplied) at least 5 mm (0.2 in.) thick between the raised floor panels and the mounting frame, which should also be isolated from the metallic floor structure.

Installation on Floor Stand

1. Install the floor stand.

NOTE: Install a field-supplied, 5-mm thick (minimum) flexible rubber seal between the cooling unit and the floor stand.

2. Secure the cooling unit to the floor stand with M8 screws.

NOTE: The minimum raised floor height is 203.2 mm (8 in.).

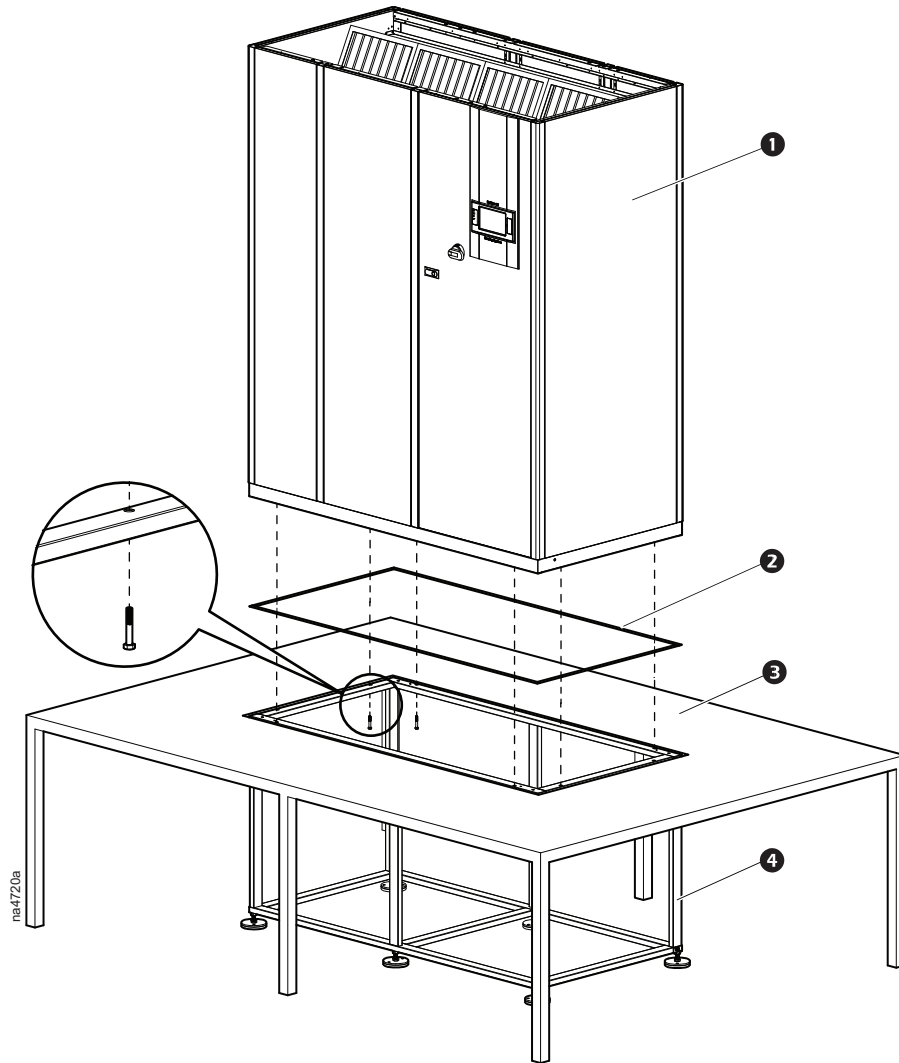

NOTE: 200-mm sub-bases are installed above floor. 500-mm sub-bases can be installed above or below the floor.

Item	Description
①	Cooling unit
②	Flexible seal (field supplied)
③	M8 screws
④	Sub-base
⑤	Raised floor

Installation on Sub-Base

⚠ WARNING

TIPPING HAZARD

The equipment is heavy and can easily be tipped. For safety purposes, adequate personnel must be present when moving this equipment.

Failure to follow these instructions can result in death, serious injury, or equipment damage.

NOTE: Sub-base installations can be performed in non-raised and raised floor environments.

1. Install the sub-base.

NOTE: Install a field-supplied, 5-mm thick (minimum) flexible rubber seal between the cooling unit and the sub-base.

2. Secure the cooling unit to the sub-base with M8 screws.

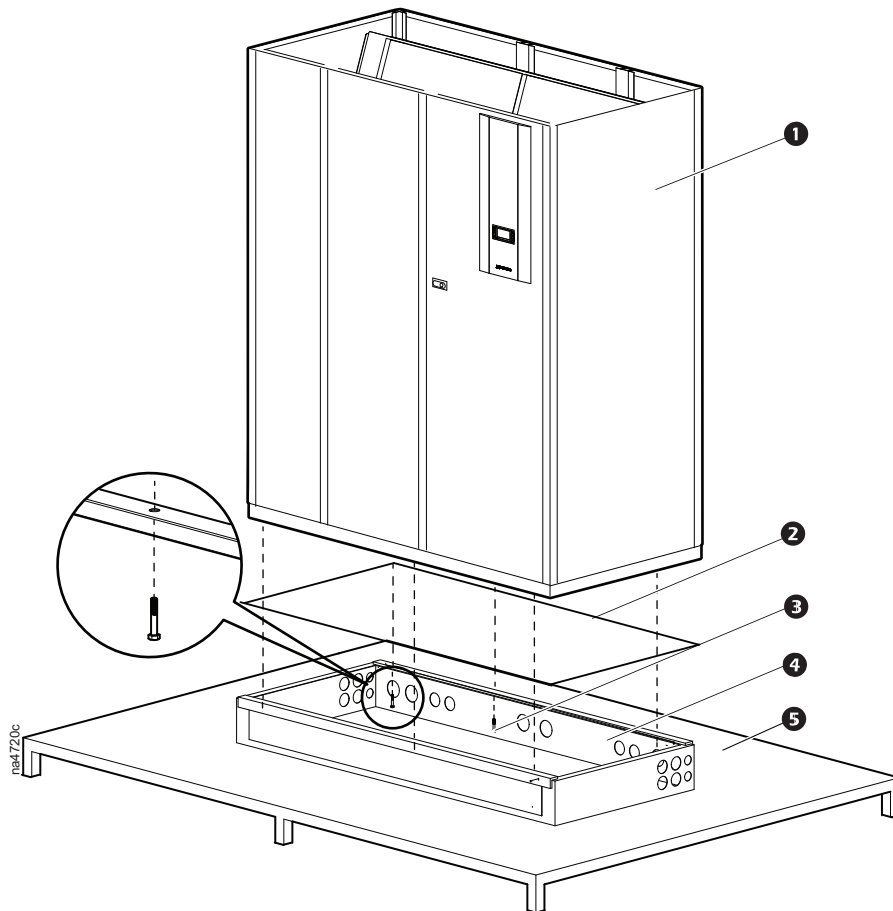

NOTE: 200-mm sub-bases are installed above floor. 500-mm sub-bases can be installed above or below the floor.

Item	Description
①	Cooling unit
②	Flexible seal (field supplied)
③	M8 screws
④	Sub-base
⑤	Raised floor

Opening the Door and Removing the Front Panels

⚠ WARNING
ELECTRICAL HAZARD
Before servicing, disconnect the power supply.
Failure to follow these instructions can result in death, serious injury, or equipment damage.

⚠ WARNING
HEAVY EQUIPMENT
The panels are heavy. Use extreme caution when moving.
Failure to follow these instructions can result in death, serious injury, or equipment damage.

Main disconnect switch

Each unit is provided with an external pistol handle main switch with an interlocking door. The main switch is positioned below the touch screen display.

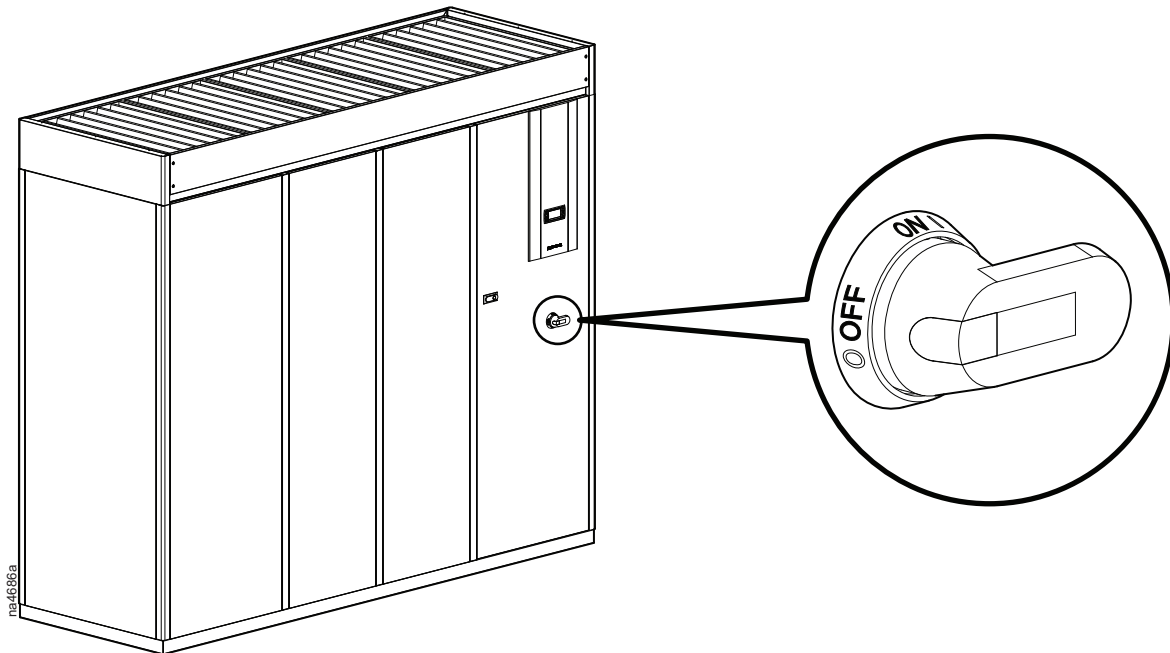

Opening the door

1. Turn the unit disconnect handle to the OFF position before opening the front panel.
2. Push the button and pull the handle gently outwards.
3. Turn the handle downwards until the door opens.

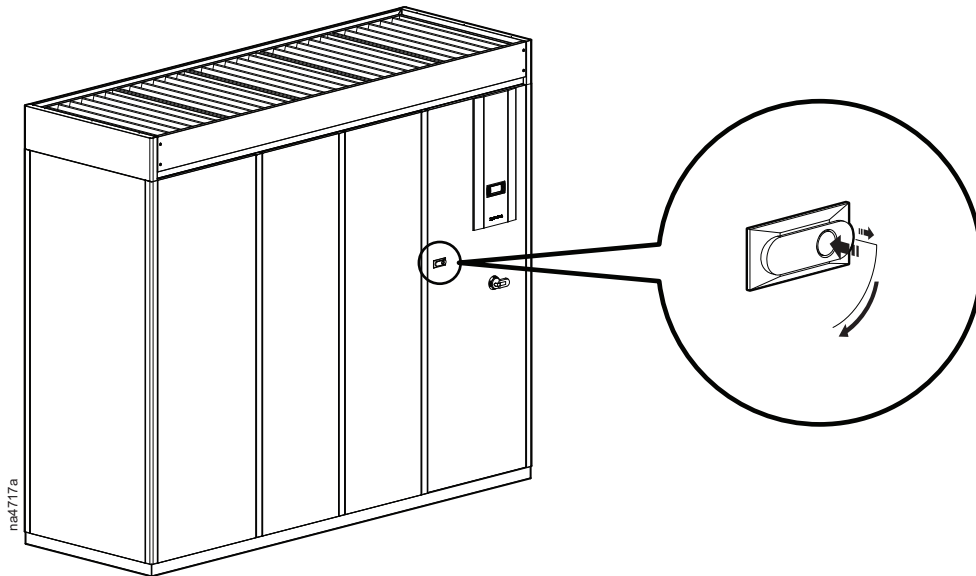

Removal

1. Firmly hold the panel at the top and pull straight out.
2. Lift and incline the panel outwards until it is completely removed.

PANEL MOUNTING

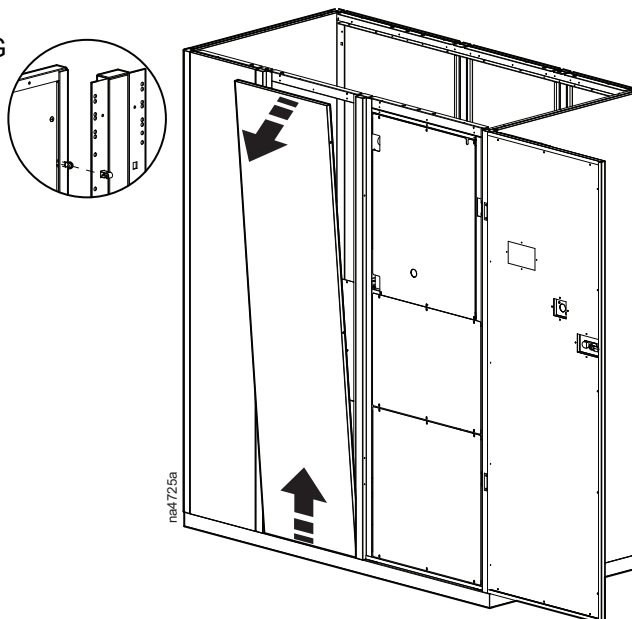

NOTE: After removing the side panels, a protective internal panel blocks access to the inside of the unit.

Internal Protection and Rear Panels

The mechanical compartment, the electric heaters (if present), and the humidifier (if present) are protected by internal protection panels for safety reasons and to allow the opening of the external panels without triggering the safety alarms.

⚠ WARNING
ELECTRICAL HAZARD
Do not remove rear panels if the equipment is operating.
Failure to follow these instructions can result in death, serious injury, or equipment damage.

NOTE: Both the internal and the rear panels are fastened to the unit by screws.

NOTE: For rear return units, the rear panels are removed like the front panels.

Removal

1. Loosen the screws securing the panel.
2. Firmly hold the panel.
3. Incline the panel outwards until it is completely removed.

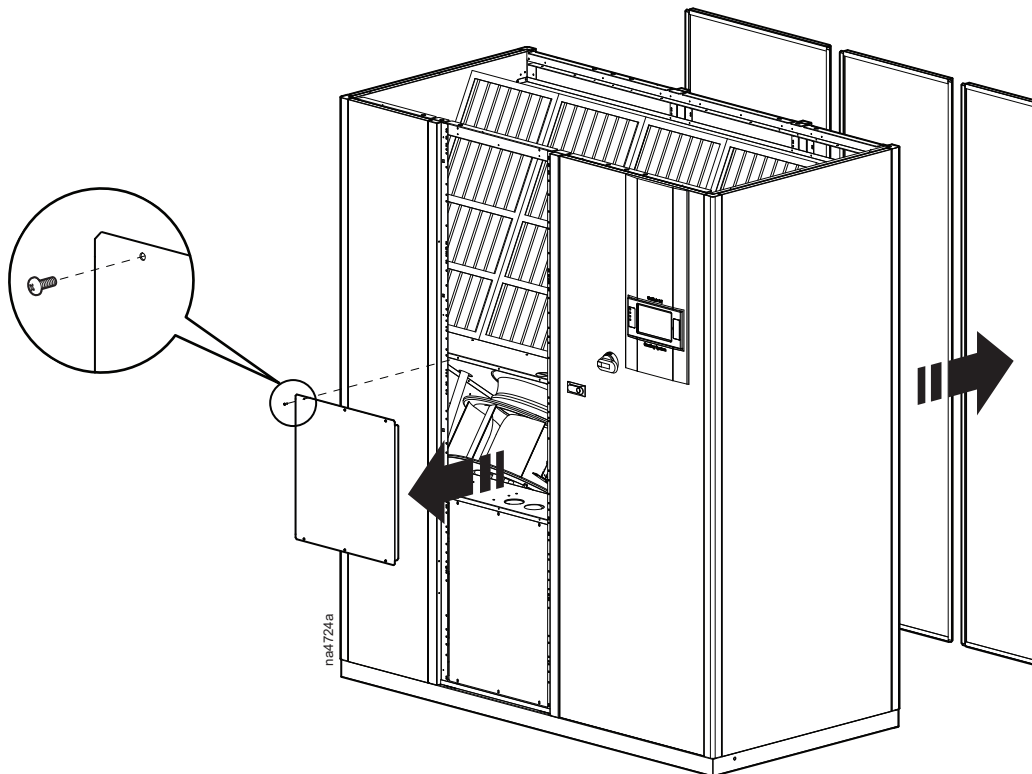

Unit Connections

Electrical Connections

⚠ ⚠ DANGER

HAZARD OF ELECTRIC SHOCK, EXPLOSION, OR ARC FLASH

Turn off all power supplying this equipment before working on the equipment. All electrical work must be performed by licensed electricians. Practice Lockout/Tagout procedures. Do not wear jewelry when working with electrical equipment.

Failure to follow these instructions will result in death or serious injury.

⚠ WARNING

QUALIFIED PERSONNEL ONLY

- Electrical connections from the unit to the power supply must ONLY be made by a licensed electrician.
- Electrical lines must be installed in compliance with all local and national codes.

Failure to follow these instructions can result in death, serious injury, or equipment damage.

NOTE: Air-cooled units are pressure activated. Low voltage connections between indoor unit and condenser are not required.

Connecting power to the unit

1. Use suitable equipment to check the grounding system efficiency.
2. Ensure that the facility voltage and frequency correspond to those of the unit name plate.
3. Ensure the main disconnect switch is in the OFF position. See “Main disconnect switch” on page 21
4. If locked, press the button on the door latch and rotate the handle downward to open the door.
5. Remove the cover from the main field wiring junction box.



See the wiring diagram attached to the equipment and connect the building power supply line to the terminal block inside the junction box.

Setting the unit power supply voltage

⚠ WARNING

MOVING PARTS

Do not operate unit with panels removed.

Failure to follow these instructions can result in death, serious injury, or equipment damage.

1. Verify that the appropriate voltage is set according to the nominal line voltage of the main input power supply.
Factory setting is 230 V.

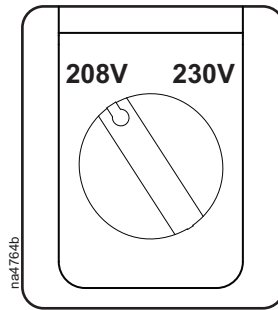

2. If necessary, modify the voltage on the selector.

Drain Connections

The condensate water drains from the tray through a 32 mm (1 1/4 in.) flexible tube fitted in the unit.

If the unit is equipped with a humidifier, ensure the humidifier connection is connected to the building drain.



See "Humidifier connections" on page 40 for information about connecting to building drains on units with a humidifier.

Connecting to building drains (without humidifier)

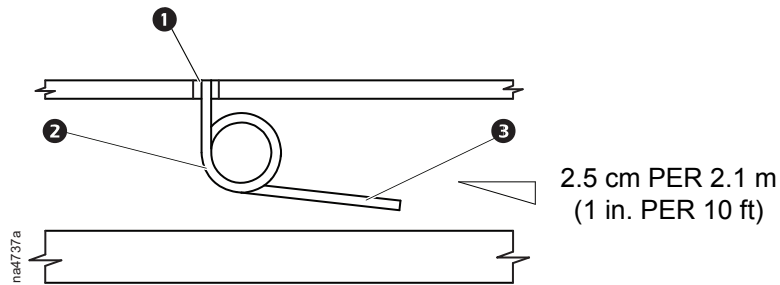

Item	Description
①	Drain
②	Trap
③	Minimum slope

NOTICE

COMPLIANCE REQUIREMENT

The installation must comply with local plumbing codes.

Failure to follow these instructions can result in equipment damage.

1. Connect the unit drainage tube to the building drains using a rubber or plastic tube with a 1 in. (25.4 cm) internal diameter.
2. Use a trap on the external drainage tube in order to avoid unpleasant odors and to allow the condensate pan to drain properly. Consult local building codes for drain requirements.
3. Once the connections have been made, pour water into the condensate drain until the trap inside the unit is full.

Water Piping Connections

For all water connections (except for the condensate drain):

1. Use shutoff valves (not supplied) to isolate the unit from the water circuit. If possible, use full port ball valves to minimize the pressure drop.
2. Check that the water pipe sizes and the circulating pump quality are adequate; insufficient water flow affects unit performance.
3. Check that the water flow directions are verified and connected properly between the unit and building.

NOTE: Assure that all pipes are free of debris and assure all system strainers are in place and oriented in the correct direction.

4. Insulate all water pipes with closed cell insulating material avoiding air gaps (for example: Armaflex™ or equivalent) to avoid condensation. The insulation must allow accessibility to the valves and three-piece joints.

5. Check that the water circuits are supplied with a maximum water pressure of 2068 kPa (300 psi). Install a safety valve with a setpoint of no more than 2068 kPa (300 psi).

NOTICE

DRAINAGE REQUIREMENT

Draining the unit is recommended after prolonged inactivity.

Failure to follow these instructions can result in equipment damage.

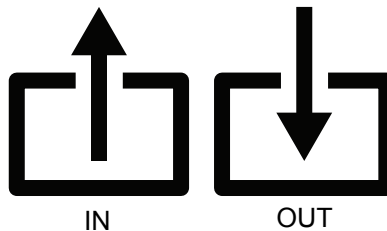
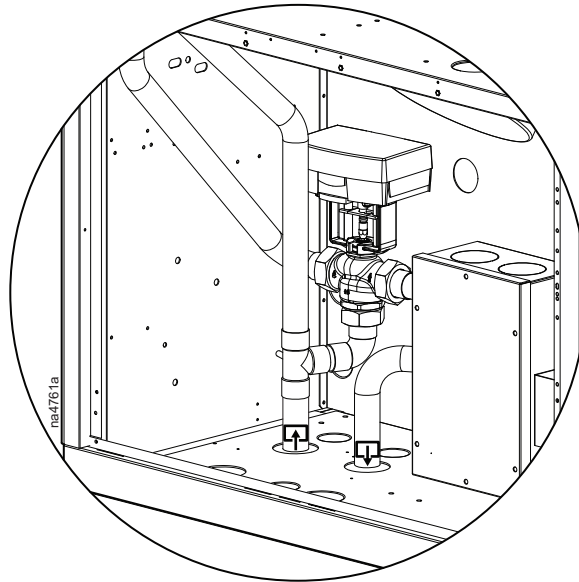

Filling the chilled water circuit

NOTE: The water used to fill the chilled water circuit must be filtered with a minimum 20 mesh stainless steel screen.

NOTICE
CHILLED WATER CIRCUIT REQUIREMENT
Filling the chilled water circuit must be done by a qualified mechanical contractor.
Failure to follow these instructions can result in equipment damage.

1. Before use, disconnect the power supply.
2. Clean the primary circuits before filling the units (a particulate strainer should be installed in the supply water piping within close proximity to the unit).
3. Check that all unit bleed valves are closed.

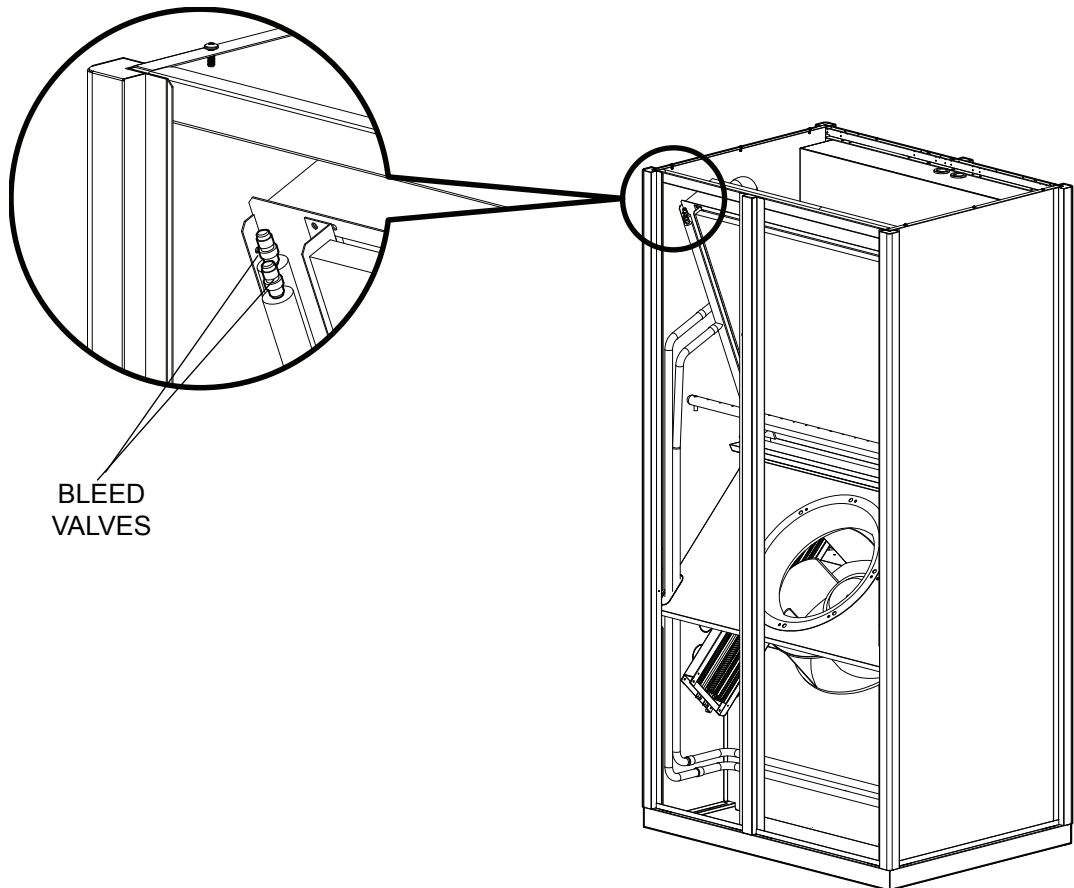

NOTE: The location of bleed valves depends on the unit type and frame size.

4. Open the isolation valves (field installed).
5. Open the bleed valve and wait for the water to come out.
6. Close the valve once all air is removed.
7. Repeat step 5 and step 6, if necessary, to remove all air.

Access to bleed valves

FRONT OR TOP ACCESS
TDCV0700

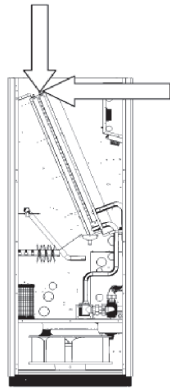

FRONT ACCESS FROM
FAN COMPARTMENT
TUCV0700

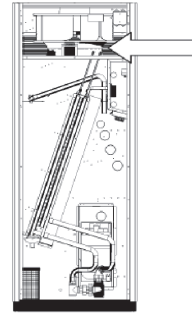

FRONT OR TOP ACCESS
TDCV1000-2500

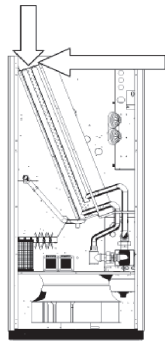

FRONT ACCESS FROM REAR
OF ELECTRICAL PANEL
TUCV1000-2500

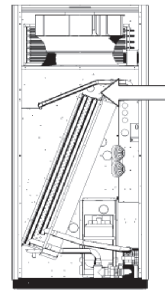

FRONT OR UP ACCESS
TDCV3400-4300

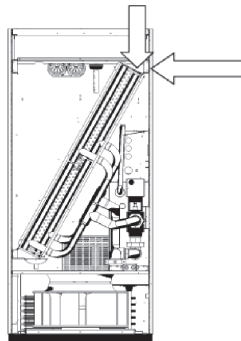

FRONT ACCESS FROM REAR
OF ELECTRICAL PANEL
TUCV3400-4300

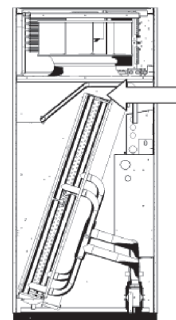

Manual Start Up and Shut Down

Starting the unit

1. Unlock the main switch.
2. Open the door and remove the closer panel if necessary.
3. Remove the metal screen from the electrical panel using a screwdriver.
4. Position all of the circuit breakers to "I" (on).
5. Re-install the cover metal sheet to the electrical panel and secure with the screws.
6. Verify all traps are pre-charged with water and all system pipes have been bled of air.
7. For internal pipe, it is necessary to remove the frontal security metal sheet.
8. Close the door and the front panels.
9. On the user interface, press the ENTER button. A sliding bar and a fan icon will appear on the display.



If an alarm is indicated, consult the *Uniflair Chilled Water and Direct Expansion Operation and Maintenance Manual*.

Turn Off the Unit

1. On the first user interface screen, press UP or DOWN buttons until the SWITCH OFF UNIT screen appears.
2. Press ENTER. The following icons will appear.

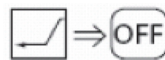

1. Press the ENTER button.



For more information, see the *Uniflair Chilled Water and Direct Expansion Operation and Maintenance Manual*.

Settings and Adjustments

All the units leave the factory with a nominal fan speed setting that allows the nominal air flow with 0.08 in. of external static pressure (ESP).

Power Supply 208-230V/3pH/60Hz		
Model	Normal Air Flow [CFM]	Fan Speed [%]
0700D	3650	54
1000D	6030	72
1200D	6320	76
1700D	8650	61
2500D	11000	74
3400D	14700	72
4000D	15300	76
4300D	17350	85

Power Supply 480V/3pH/60Hz		
Model	Normal Air Flow [CFM]	Fan Speed [%]
0700G	3650	62
1000G	6030	81
1200G	6320	86
1700G	8650	66
2500G	11000	81
3400G	14700	76
4000G	15300	80
4300G	17350	89

To reach the CFM required by the system with fans on, the fan output percentage can be adjusted from the user interface.

Selecting the Fan Output Percentage

1. On the user interface press PROGRAM.
2. Using the UP or DOWN button, select **Service Menu**.
3. Press the ENTER.
4. Enter the password (see the envelope attached to the manual).
5. Using the UP or DOWN button, select **Hardware Setting**.
6. Press ENTER.
7. Using the UP or DOWN button, select **Evaporating Fan**.
8. Press ENTER.
9. Set the value.
10. Press ENTER.

NOTE: The maximum pressure available expressed in the inches of water column for each unit size and voltage is indicated in the following section. The values are given for the maximum air flow expressed in CFM.

Units Without Electrical Heaters

NOTE: Feet per minute through the cooling coil should be maintained below 500 fpm to prevent condensation carry-over.

TDCV0700D						
Air Flow (CFM)	2680	3197	3714	4230	4747	5264
Fan Speed [%]	ESP in.wg					
45	0.08	-	-	-	-	-
50	0.52	0.02	-	-	-	-
55	0.96	0.46	-	-	-	-
60	1.4	0.9	0.36	-	-	-
65	1.83	1.33	0.79	0.22	-	-
70	2.27	1.76	1.23	0.65	0.03	-
75	2.7	2.2	1.66	1.09	0.46	-
80	3.05	2.54	2	1.43	0.81	0.08
85	3.05	2.54	2	1.43	0.81	0.08
100	3.05	2.54	2	1.43	0.81	0.08

TDCV1000D						
Air Flow (CFM)	3547	4188	4829	5470	6111	6752
Fan Speed [%]	ESP in.wg					
45	0.08	-	-	-	-	-
50	0.52	-	-	-	-	-
55	0.93	0.39	-	-	-	-
60	1.32	0.78	0.23	-	-	-
65	1.69	1.14	0.59	0.07	-	-
70	2.02	1.47	0.92	0.41	-	-
75	2.32	1.77	1.22	0.71	0.2	-
80	2.58	2.04	1.49	0.97	0.46	-
85	2.81	2.26	1.71	1.19	0.68	0.08
100	2.81	2.26	1.71	1.19	0.68	0.08

TDCV1200D						
Air Flow (CFM)	3523	4158	4793	5429	6064	6699
Fan Speed [%]	ESP in.wg					
45	0.08	-	-	-	-	-
50	0.52	-	-	-	-	-
55	0.93	0.39	-	-	-	-
60	1.32	0.78	0.22	-	-	-
65	1.69	1.14	0.59	0.07	-	-
70	2.02	1.48	0.92	0.4	-	-
75	2.32	1.78	1.22	0.7	0.19	-
80	2.58	2.04	1.48	0.96	0.45	-
85	2.81	2.26	1.71	1.19	0.67	0.08
100	2.81	2.26	1.71	1.19	0.67	0.08

TDCV1700D						
Air Flow (CFM)	6187	7236	8284	9333	10382	11430
Fan Speed [%]	ESP in.wg					
45	0.08	-	-	-	-	-
50	0.52	0.04	-	-	-	-
55	0.93	0.45	-	-	-	-
60	1.32	0.84	0.28	-	-	-
65	1.69	1.21	0.65	0.07	-	-
70	2.02	1.54	0.98	0.41	-	-
75	2.32	1.84	1.28	0.71	0.15	-
80	2.58	2.1	1.55	0.97	0.41	-
85	2.81	2.33	1.77	1.19	0.63	0.08
100	2.81	2.33	1.77	1.19	0.63	0.08

TDCV2500D						
Air Flow (CFM)	6727	7913	9099	10284	11470	12656
Fan Speed [%]	ESP in.wg					
45	0.08	-	-	-	-	-
50	0.52	-	-	-	-	-
55	0.93	0.4	-	-	-	-
60	1.32	0.79	0.23	-	-	-
65	1.69	1.16	0.59	0.04	-	-
70	2.02	1.49	0.92	0.38	-	-
75	2.32	1.79	1.22	0.68	0.15	-
80	2.58	2.05	1.49	0.94	0.41	-
85	2.81	2.28	1.71	1.16	0.63	0.08
100	2.81	2.28	1.71	1.16	0.63	0.08

TDCV3400D						
Air Flow (CFM)	9464	11090	12715	14340	15965	17590
Fan Speed [%]	ESP in.wg					
45	0.08	-	-	-	-	-
50	0.52	0.02	-	-	-	-
55	0.93	0.44	-	-	-	-
60	1.32	0.83	0.27	-	-	-
65	1.69	1.19	0.63	0.06	-	-
70	2.02	1.53	0.96	0.39	-	-
75	2.32	1.83	1.26	0.69	0.14	-
80	2.58	2.09	1.53	0.96	0.4	-
85	2.81	2.31	1.75	1.18	0.63	0.08
100	2.81	2.31	1.75	1.18	0.63	0.08

TDCV4000D						
Air Flow (CFM)	9315	10904	12493	14082	15671	17259
Fan Speed [%]	ESP in.wg					
45	0.08	-	-	-	-	-
50	0.52	0.03	-	-	-	-
55	0.93	0.45	-	-	-	-
60	1.32	0.84	0.28	-	-	-
65	1.69	1.2	0.64	0.07	-	-
70	2.02	1.54	0.98	0.4	-	-
75	2.32	1.84	1.28	0.7	0.14	-
80	2.58	2.1	1.54	0.97	0.41	-
85	2.81	2.32	1.76	1.19	0.63	0.08
100	2.81	2.32	1.76	1.19	0.63	0.08

TDCV4300D						
Air Flow (CFM)	9591	11255	12918	14581	16244	17907
Fan Speed [%]	ESP in.wg					
45	0.08	-	-	-	-	-
50	0.52	0.01	-	-	-	-
55	0.93	0.43	-	-	-	-
60	1.32	0.82	0.25	-	-	-
65	1.69	1.18	0.62	0.05	-	-
70	2.02	1.52	0.95	0.38	-	-
75	2.32	1.82	1.25	0.68	0.14	-
80	2.58	2.08	1.51	0.95	0.4	-
85	2.81	2.3	1.74	1.17	0.62	0.08
100	2.81	2.3	1.74	1.17	0.62	0.08

TDCV0700G						
Air Flow (CFM)	2477	3007	3537	4068	4598	5128
Fan Speed [%]	ESP in.wg					
45	0.08	-	-	-	-	-
50	0.41	-	-	-	-	-
55	0.73	0.27	-	-	-	-
60	1.05	0.63	0.08	-	-	-
65	1.36	0.99	0.48	-	-	-
70	1.67	1.33	0.87	0.28	-	-
75	1.97	1.65	1.22	0.68	0.01	-
80	2.28	1.97	1.56	1.05	0.42	-
85	2.58	2.27	1.88	1.39	0.79	0.08
100	2.58	2.27	1.88	1.39	0.79	0.08

TDCV1000G						
Air Flow (CFM)	3764	4348	4932	5516	6100	6684
Fan Speed [%]	ESP in.wg					
45	0.08	-	-	-	-	-
50	0.37	0.19	-	-	-	-
55	0.66	0.48	0.21	-	-	-
60	0.95	0.77	0.5	0.1	-	-
65	1.24	1.05	0.79	0.38	-	-
70	1.52	1.34	1.07	0.67	0.07	-
75	1.81	1.63	1.36	0.96	0.36	-
80	2.1	1.91	1.65	1.24	0.64	-
85	2.39	2.2	1.94	1.53	0.93	0.08
100	2.39	2.2	1.94	1.53	0.93	0.08

TDCV1200G						
Air Flow (CFM)	3689	4282	4874	5466	6059	6651
Fan Speed [%]	ESP in.wg					
45	0.08	-	-	-	-	-
50	0.37	0.19	-	-	-	-
55	0.66	0.48	0.21	-	-	-
60	0.95	0.76	0.5	0.1	-	-
65	1.24	1.05	0.79	0.38	-	-
70	1.52	1.34	1.07	0.67	0.07	-
75	1.81	1.62	1.36	0.96	0.36	-
80	2.1	1.91	1.65	1.25	0.65	-
85	2.39	2.2	1.94	1.54	0.94	0.08
100	2.39	2.2	1.94	1.54	0.94	0.08

TDCV1700G						
Air Flow (CFM)	5603	6874	8146	9417	10688	11960
Fan Speed [%]	ESP in.wg					
45	0.08	-	-	-	-	-
50	0.37	0.07	-	-	-	-
55	0.66	0.36	0.06	-	-	-
60	0.95	0.65	0.34	-	-	-
65	1.24	0.94	0.63	0.24	-	-
70	1.52	1.22	0.92	0.53	-	-
75	1.81	1.51	1.2	0.81	0.27	-
80	2.1	1.8	1.49	1.1	0.56	-
85	2.39	2.09	1.78	1.39	0.85	0.08
100	2.39	2.09	1.78	1.39	0.85	0.08

TDCV2500G						
Air Flow (CFM)	6536	7795	9055	10314	11574	12833
Fan Speed [%]	ESP in.wg					
45	0.08	-	-	-	-	-
50	0.37	0.15	-	-	-	-
55	0.66	0.44	0.18	-	-	-
60	0.95	0.73	0.46	0.07	-	-
65	1.24	1.02	0.75	0.36	-	-
70	1.52	1.3	1.04	0.64	0.06	-
75	1.81	1.59	1.32	0.93	0.35	-
80	2.1	1.88	1.61	1.22	0.64	-
85	2.39	2.17	1.9	1.51	0.93	0.08
100	2.39	2.17	1.9	1.51	0.93	0.08

TDCV3400G						
Air Flow (CFM)	8660	10586	12512	14438	16364	18289
Fan Speed [%]	ESP in.wg					
45	0.08	-	-	-	-	-
50	0.37	0.09	-	-	-	-
55	0.66	0.38	0.09	-	-	-
60	0.95	0.67	0.38	-	-	-
65	1.24	0.96	0.66	0.27	-	-
70	1.52	1.24	0.95	0.56	0.01	-
75	1.81	1.53	1.23	0.85	0.29	-
80	2.1	1.82	1.52	1.14	0.58	-
85	2.39	2.11	1.81	1.43	0.87	0.08
100	2.39	2.11	1.81	1.43	0.87	0.08

TDCV4000G						
Air Flow (CFM)	8446	10363	12281	14199	16116	18034
Fan Speed [%]	ESP in.wg					
45	0.08	-	-	-	-	-
50	0.37	0.08	-	-	-	-
55	0.66	0.37	0.06	-	-	-
60	0.95	0.66	0.35	-	-	-
65	1.24	0.94	0.64	0.25	-	-
70	1.52	1.23	0.92	0.54	-	-
75	1.81	1.51	1.21	0.82	0.28	-
80	2.1	1.8	1.5	1.11	0.57	-
85	2.39	2.09	1.79	1.4	0.86	0.08
100	2.39	2.09	1.79	1.4	0.86	0.08

TDCV4300G High Efficiency						
Air Flow (CFM)	8849	10784	12718	14653	16587	18521
Fan Speed [%]	ESP in.wg					
45	0.08	-	-	-	-	-
50	0.37	0.11	-	-	-	-
55	0.66	0.4	0.11	-	-	-
60	0.95	0.68	0.4	0.01	-	-
65	1.24	0.97	0.68	0.3	-	-
70	1.52	1.26	0.97	0.58	0.02	-
75	1.81	1.54	1.26	0.87	0.31	-
80	2.1	1.83	1.54	1.16	0.6	-
85	2.39	2.12	1.83	1.45	0.89	0.08
100	2.39	2.12	1.83	1.45	0.89	0.08

Units With Electrical Heaters

NOTE: Feet per minute through the cooling coil should be maintained below 500 fpm to prevent condensation carry-over.

TDCV0700D						
Air Flow (CFM)	3531	3865	4199	4533	4867	5201
Fan Speed [%]	ESP in.wg					
55	0.08	-	-	-	-	-
60	0.52	0.15	-	-	-	-
65	0.95	0.58	0.2	-	-	-
70	1.38	1.02	0.64	0.23	-	-
75	1.82	1.45	1.07	0.67	0.23	-
85	2.15	1.79	1.4	1	0.57	0.08
100	2.15	1.79	1.4	1	0.57	0.08

TDCV1000D						
Air Flow (CFM)	5416	5660	5905	6150	6395	6640
Fan Speed [%]	ESP in.wg					
66	0.08	-	-	-	-	-
71	0.41	0.21	0.01	-	-	-
76	0.71	0.51	0.31	0.1	-	-
81	0.96	0.77	0.56	0.36	0.13	-
85	1.16	0.96	0.76	0.55	0.33	0.08
100	1.16	0.96	0.76	0.55	0.33	0.08

TDCV1200D						
Air Flow (CFM)	5416	5650	5884	6118	6353	6587
Fan Speed [%]	ESP in.wg					
66	0.08	-	-	-	-	-
71	0.41	0.21	0.02	-	-	-
76	0.7	0.5	0.31	0.11	-	-
81	0.95	0.76	0.56	0.36	0.15	-
85	1.12	0.92	0.73	0.53	0.31	0.08
100	1.12	0.92	0.73	0.53	0.31	0.08

TDCV1700D						
Air Flow (CFM)	7474	8146	8817	9489	10161	10832
Fan Speed [%]	ESP in.wg					
54	0.08	-	-	-	-	-
59	0.48	0.09	-	-	-	-
64	0.85	0.46	0.06	-	-	-
69	1.19	0.8	0.4	0	-	-
74	1.5	1.11	0.71	0.31	-	-
79	1.77	1.38	0.99	0.59	0.19	-
85	2.05	1.67	1.27	0.87	0.47	0.08
100	2.05	1.67	1.27	0.87	0.47	0.08

TDCV2500D						
Air Flow (CFM)	9653	10095	10536	10978	11420	11862
Fan Speed [%]	ESP in.wg					
65	0.08	-	-	-	-	-
70	0.41	0.19	-	-	-	-
75	0.71	0.49	0.26	0.04	-	-
80	0.98	0.75	0.53	0.31	0.08	-
85	1.2	0.97	0.75	0.53	0.31	0.08
100	1.2	0.97	0.75	0.53	0.31	0.08

TDCV3400D						
Air Flow (CFM)	12066	12780	13495	14209	14924	15639
Fan Speed [%]	ESP in.wg					
60	0.08	-	-	-	-	-
65	0.45	0.15	-	-	-	-
70	0.78	0.48	0.18	-	-	-
75	1.08	0.79	0.48	0.18	-	-
80	1.35	1.05	0.75	0.45	0.14	-
85	1.58	1.28	0.97	0.67	0.37	0.07
100	1.59	1.29	0.99	0.68	0.38	0.08

TDCV4000D						
Air Flow (CFM)	12066	12736	13407	14077	14747	15418
Fan Speed [%]	ESP in.wg					
61	0.08	-	-	-	-	-
66	0.44	0.15	-	-	-	-
71	0.77	0.49	0.2	-	-	-
76	1.07	0.78	0.49	0.2	-	-
81	1.33	1.04	0.75	0.46	0.17	-
85	1.53	1.24	0.95	0.66	0.37	0.08
100	1.53	1.24	0.95	0.66	0.37	0.08

TDCV4300D High Efficiency						
Air Flow (CFM)	13892	14282	14673	15064	15454	15845
Fan Speed [%]	ESP in.wg					
70	0.08	-	-	-	-	-
75	0.38	0.22	0.06	-	-	-
80	0.65	0.49	0.32	0.16	0	-
85	0.87	0.71	0.55	0.39	0.23	0.07
100	0.89	0.72	0.56	0.4	0.24	0.08

TDCV0700G						
Air Flow (CFM)	3531	3838	4145	4451	4758	5065
Fan Speed [%]	ESP in.wg					
60	0.08	-	-	-	-	-
65	0.48	0.13	-	-	-	-
70	0.86	0.53	0.16	-	-	-
75	1.22	0.91	0.56	0.17	-	-
80	1.55	1.26	0.93	0.57	0.16	-
85	1.84	1.56	1.24	0.9	0.51	0.08
100	1.84	1.56	1.24	0.9	0.51	0.08

TDCV1000G						
Air Flow (CFM)	5416	5655	5895	6135	6374	6614
Fan Speed [%]	ESP in.wg					
60	0.08	-	-	-	-	-
65	0.37	0.15	-	-	-	-
70	0.65	0.44	0.19	-	-	-
75	0.94	0.73	0.48	0.19	-	-
80	1.23	1.01	0.77	0.48	0.15	-
85	1.52	1.3	1.06	0.77	0.44	0.06
100	1.54	1.33	1.08	0.79	0.46	0.08

TDCV1200G						
Air Flow (CFM)	5414	5648	5881	6114	6348	6581
Fan Speed [%]	ESP in.wg					
60	0.08	-	-	-	-	-
65	0.37	0.16	-	-	-	-
70	0.65	0.44	0.2	-	-	-
75	0.94	0.73	0.49	0.21	-	-
80	1.23	1.02	0.78	0.5	0.18	-
85	1.5	1.29	1.05	0.77	0.45	0.08
100	1.5	1.29	1.05	0.77	0.45	0.08

TDCV1700G						
Air Flow (CFM)	7476	8268	9059	9851	10642	11434
Fan Speed [%]	ESP in.wg					
55	0.08	-	-	-	-	-
60	0.37	0.13	-	-	-	-
65	0.65	0.42	0.15	-	-	-
70	0.94	0.71	0.44	0.11	-	-
75	1.23	0.99	0.72	0.4	-	-
80	1.52	1.28	1.01	0.68	0.29	-
85	1.8	1.57	1.29	0.97	0.57	0.08
100	1.8	1.57	1.29	0.97	0.57	0.08

TDCV2500G						
Air Flow (CFM)	9653	10179	10706	11233	11759	12286
Fan Speed [%]	ESP in.wg					
61	0.08	-	-	-	-	-
66	0.37	0.16	-	-	-	-
71	0.65	0.45	0.21	-	-	-
76	0.94	0.74	0.5	0.22	-	-
81	1.23	1.02	0.79	0.51	0.19	-
85	1.48	1.28	1.04	0.77	0.45	0.08
100	1.48	1.28	1.04	0.77	0.45	0.08

TDCV3400G						
Air Flow (CFM)	12066	12959	13853	14747	15640	16534
Fan Speed [%]	ESP in.wg					
60	0.08	-	-	-	-	-
65	0.37	0.15	-	-	-	-
70	0.65	0.44	0.2	-	-	-
75	0.94	0.73	0.49	0.21	-	-
80	1.23	1.01	0.77	0.5	0.18	-
85	1.5	1.28	1.04	0.77	0.45	0.08
100	1.5	1.28	1.04	0.77	0.45	0.08

TDCV4000G						
Air Flow (CFM)	12066	12912	13759	14605	15452	16298
Fan Speed [%]	ESP in.wg					
61	0.08	-	-	-	-	-
66	0.37	0.16	-	-	-	-
71	0.65	0.44	0.21	-	-	-
76	0.94	0.73	0.5	0.23	-	-
81	1.23	1.02	0.79	0.52	0.22	-
85	1.43	1.23	0.99	0.73	0.43	0.08
100	1.43	1.23	0.99	0.73	0.43	0.08

TDCV4300G High Efficiency						
Air Flow (CFM)	13889	14461	15032	15604	16175	16747
Fan Speed [%]	ESP in.wg					
67	0.08	-	-	-	-	-
72	0.37	0.2	0.02	-	-	-
77	0.65	0.49	0.3	0.1	-	-
82	0.94	0.78	0.59	0.39	0.17	-
85	1.1	0.93	0.75	0.55	0.32	0.08
100	1.1	0.93	0.75	0.55	0.32	0.08

Setting the Regulation and Safety Devices

After starting up the system, set the following setpoints:

- Room temperature (cooling and heating setpoint)
- Relative room humidity (humidification and dehumidification setpoint)
- Clogged filter differential pressure switch



See "Setting the Clogged Filter Sensors" on page 38.

IMPORTANT: Safety device settings must not be modified.

Setting the Air Flow Sensor

The fan differential pressure switch closes or opens if the fan (or one of the fans) stops working. The factory setpoint of the fan differential pressure switch is at 0.20 in.wc (0.5 mbar). It may be necessary to set the instruments after installation because the pressure difference between fan suction and discharge depends on air flow. Ensure that the contact closes when the fans are operating. To set the fan differential pressure switch:

1. Check that the pressure switch closes and opens. If the pressure switch does not close or open, gradually increase the setting until the pressure switch switches off.
2. Using an adjustment screw, set the fan differential pressure switch on a scale from 0.20 in.wc (0.5 mbar) to 1.6 in.wc (4.0 mbar).

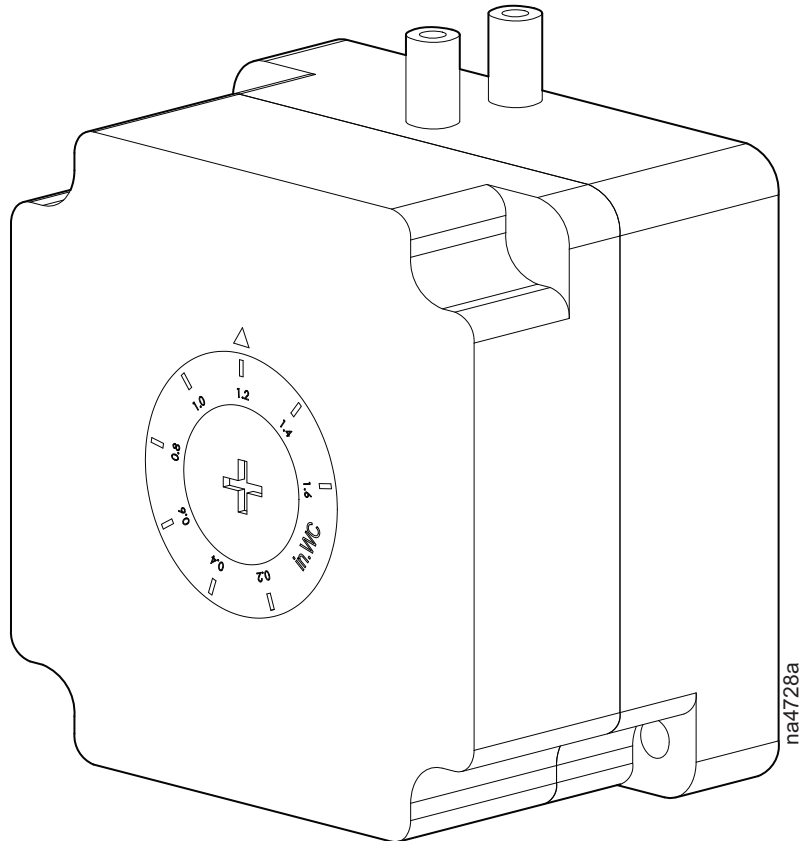

Setting the Clogged Filter Sensors

The differential pressure switch is set according to the loss of load dependent on the dirt inside the filters and the air flow. The differential pressure switch must be set at 1.2" wc (3 mbar). To set the pressure switch:

1. Using a Phillips screwdriver, turn the regulation screws to the desired value.
2. Gradually cover the air filter surface and check that the pressure switch activates when the filter is about 50-60% covered. If the pressure switch does not activate, gradually lower the setting, if it cuts in too soon, increase the setting.

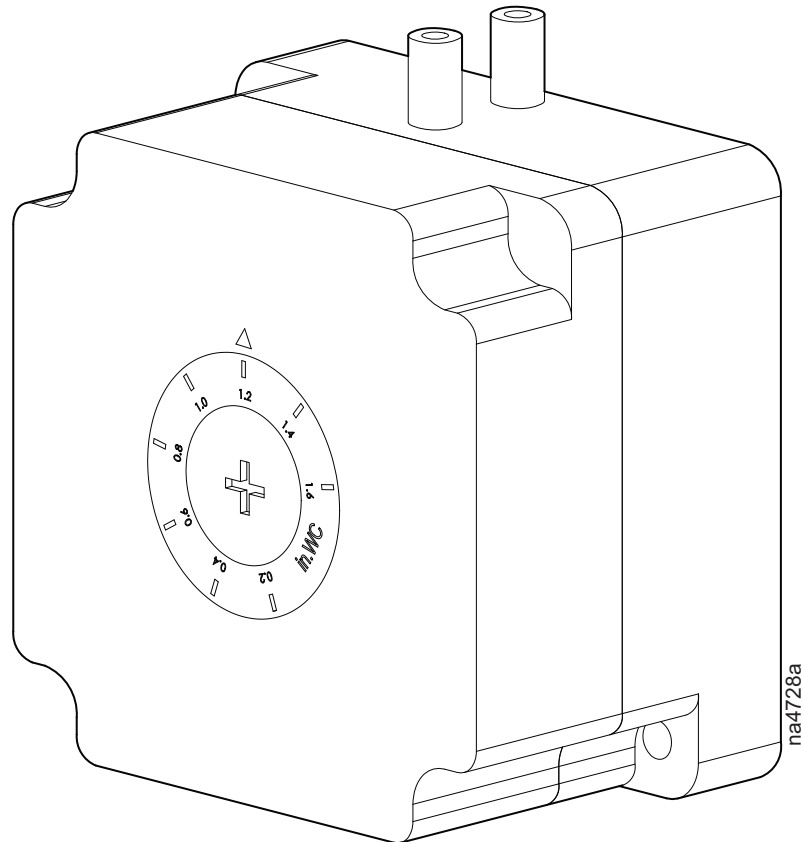

Accessories

Humidifier

Components

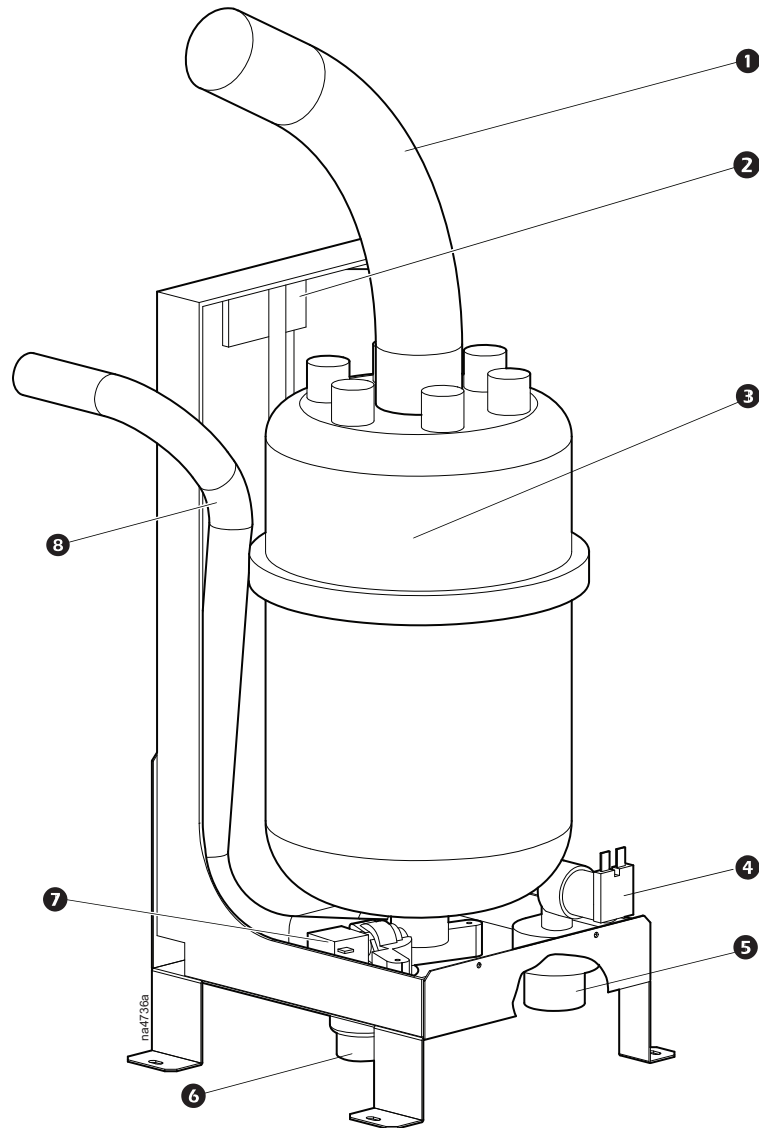

Item	Description	Item	Description
1	Steam outlet	5	Water supply connections
2	Supply water fill cup	6	Water drain connection
3	Humidifier cylinder	7	Cylinder drain solenoid valve
4	Water supply solenoid valve	8	Condensate drain pan hose

Humidifier connections

The humidifier installation requires connection to the water supply and drain lines.

NOTE: A factory-supplied threaded adapter and rubber hose are used to connect the humidifier to the piping on site.

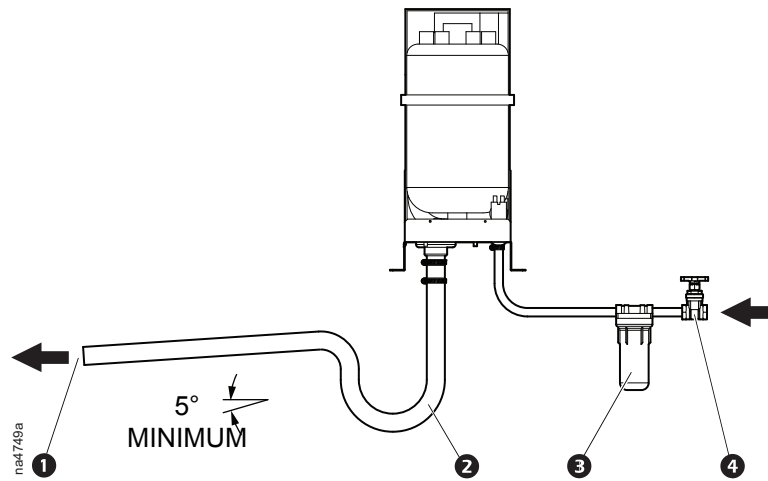

Item	Description
①	Drain line
②	Trap
③	Replaceable water cartridge filter (recommended)
④	Isolation valve

Connecting to the drainage and water supply lines

⚠ WARNING

HOT WATER HAZARD

- Use caution when servicing the humidifier. The water discharged from the humidifier is at a very high temperature.
- Use a drainage tube designed to withstand temperatures of at least 100°C (212°F).
- Keep the drainage tube away from all electrical cables and refrigerant lines.

Failure to follow these instructions can result in death, serious injury, or equipment damage.

1. Route the humidifier drainage line to the building drains using a rubber or plastic tube with a 1 1/4 in. internal diameter.
2. Use a trap on the external drainage tube to avoid unpleasant odors and water overflow from the humidifier tray. Consult local building codes for drain requirements.
3. Connect humidifier 3/4 in. hose bib connection to water supply line.
4. Once the connections have been made, pour water into the unit condensate collection tray and in the humidifier condensate collection tray until the trap is full.

Supply water

Use the values in the following table to determine the conductivity of the humidifier supply water.

NOTE: The recommended supply water pressure should be between 30–90 psig.

Description	Units	Limits	
		Minimum	Maximum
Hydrogen ion activity	pH	7	8.5
Specific conductivity at 20°C (68°F)	σ_R , 20°C (68°F)	300	1250
Total dissolved solids	TDS	*	*
Residual fixed at 180°C (356°F)	R180	*	*
Total hardness	TH	100**	400
Temporary hardness		60‡	300
Iron + manganese	mg/l Fe + Mn	0	0.2
Chlorides	ppm Cl	0	30
Silica	mg/l	0	20
Residual chloride	mg/l	0	.2
Calcium sulphate	mg/l	0	100
Metallic impurities	mg/l	0	0
Solvents, diluents, soaps, lubricants	mg/l	0	0

* Values dependent on the specific conductivity; in general: TDS @ 0.93 * s20; R180 @ 0.65 * s20

** Not lower than 200% of the Chloride content in mg/l di Cl-

‡ Not lower than 300% of the Chloride content in mg/l di Cl-

Electrical Heaters

Uniflair units can be equipped from the factory with electric heating elements complete with safety thermostats to cut off the power supply and activate the alarm in the event of overheating.

The finned elements are characterized as high efficiency in order to maintain a low power density on the surfaces, therefore limiting overheating the elements and consequently increasing their durability.

Due to the low surface temperature of the heating elements, the air ionization effect on the air is limited.

This heating system has a dual purpose:

- Heating the air to bring it up to the setpoint
- Post-heating during dehumidification in such a way as to retain the air temperature at setpoint (therefore, the capacity of heating installed is able to maintain the dry bulb temperature in the room during dehumidification)

Electrical heaters capacity with 230V/3pH/60Hz power supply

Chilled Water Unit	Number of Elements	kW	Operating Amps
0700D	2	6	15.1
1000D-1200D	3	9	22.6
1700D-2500D	5	15	37.7
3400D-4000D-4300D	6	18	45.2

Electrical heaters capacity with 208V/3pH/60Hz power supply

Chilled Water Unit	Number of Elements	kW	Operating Amps
0700D	2	4.9	13.6
1000D-1200D	3	7.4	20.4
1700D-2500D	5	12.3	34.1
3400D-4000D-4300D	6	14.7	40.9

Electrical heaters capacity with 460V/3pH/60Hz power supply

Chilled Water Unit	Number of Elements	kW	Operating Amps
0700G	2	6	7.5
1000G-1200G	4	12	15.1
1700G-2500G	4	12	15.1
3400G-4000G-4300G	6	18	22.6

Temperature and Humidity Sensor

Installation

NOTICE	
ELECTRIC STATIC DISCHARGE (ESD)	
Apply ESD protection when handling the installed sensor.	
Failure to follow these instructions can result in equipment damage.	

1. Insert a screwdriver in the slot and release the front cover of the sensor.
2. Remove the lid and fasten the screws inside the sensor to the mounting location on the unit.
3. Connect the shielded cable to the appropriate terminals on the sensor, using the electrical diagram in the unit as reference.

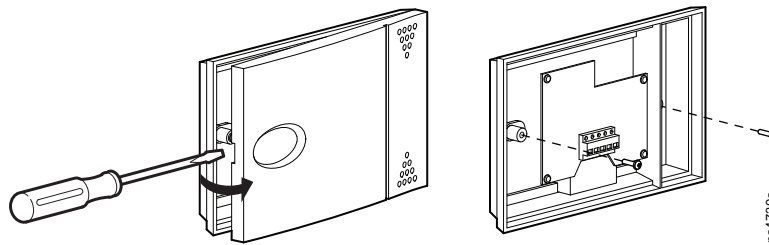

NOTE: Some cooling applications may require the sensor be mounted in the room apart from the unit. The recommended maximum distance between the sensor and the unit is 3 m (10 ft). Use only #18 AWG.

Discharge Temperature Threshold Sensor

An NTC temperature sensor is an optional accessory which maintains the supply air temperature of the unit above a threshold value. The sensor is connected to the microprocessor control system as described in the electrical diagram of the unit.

The sensor has a temperature range of -50°C (-58°F) and 50°C (122°F) and a protection level of IP67. It can be installed outside the unit by means of a cable that is 3 m (9.8 ft) long. A minimum distance of 2 m (6.5 ft) is advisable from the unit discharge, as shown in the diagram for upflow units.

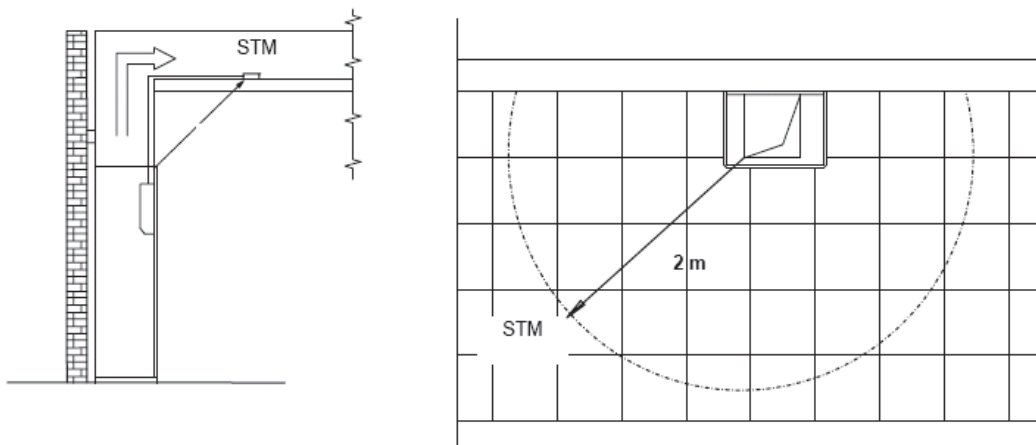

Worldwide Customer Support

Customer support for this or any other product is available at no charge in any of the following ways:

- Visit the Schneider Electric Web site to access documents in the Schneider Electric Knowledge Base and to submit customer support requests.
 - **www.schneider-electric.com** (Corporate Headquarters)
Connect to localized Schneider Electric Web sites for specific countries, each of which provides customer support information.
 - **www.schneider-electric.com/support/**
Global support searching Schneider Electric Knowledge Base and using e-support.
- Contact the Schneider Electric Customer Support Center by telephone or e-mail.
 - Local, country-specific centers: go to **www.schneider-electric.com > Support > Operations around the world** for contact information.

For information on how to obtain local customer support, contact the representative or other distributors from whom you purchased your product.

As standards, specifications, and designs change from time to time, please ask for confirmation of the information given in this publication.

© 2016 Schneider Electric. All Rights Reserved.

Uniflair and the Schneider Electric logo are trademarks owned by Schneider Electric Industries SAS S.A.S., or its affiliated companies. All other trademarks are the property of their respective owners.