

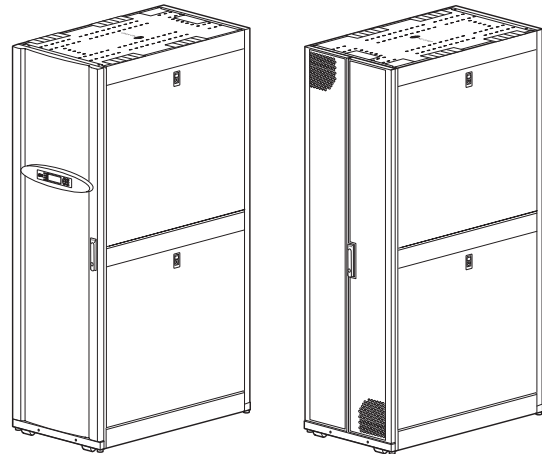

APC Smart-UPS® VT ISX Enclosure 20-30 kVA 208V for 5 Battery Modules and with Power Distribution Unit and Isolation Transformer

Installation

IMPORTANT SAFETY INSTRUCTIONS SAVE THESE INSTRUCTIONS



Always read the separate Safety sheet (990-2822) prior to the installation.



All electrical power and power control wiring must be installed by a qualified electrician, and must comply with local and national regulations for maximum power rating.



The UPS must be supplied from a: 208Y/120V or 220Y/127V 4W + GND 60Hz source.



Power terminal lug diameter: minimum 6 mm.
Torque value: 62 lbf in/7 Nm.

1 Cable entry



Make sure the UPS is in its location of use before wiring begins.

Cable entry takes place from the rear of the UPS. Open the rear doors by pulling out the lower end of the handle and turn it counterclockwise to a horizontal position to open the door.

Preparing for cabling (general)

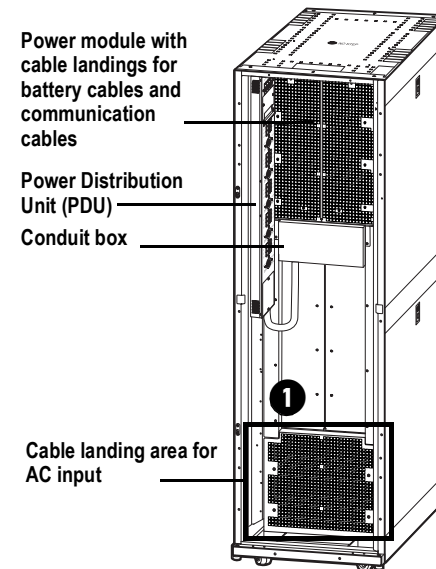

- 1 Use a torx screwdriver to loosen the four M4 screws from the cable landing cover, and remove.

Preparing for bottom and top entry

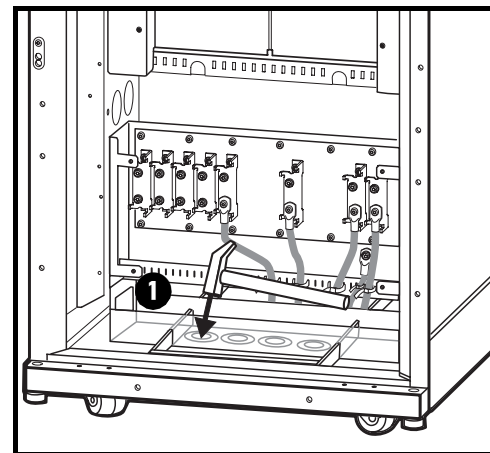

- 1 Use a hammer to punch out knockouts and line holes with grommets (not supplied).

Preparing for top cable entry

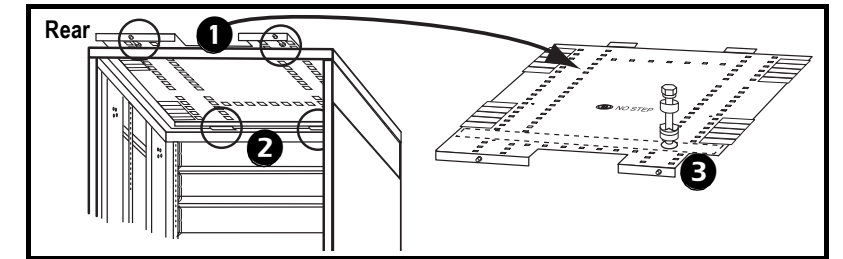

- 1 From the rear of the inside of the UPS push the top cover spring locks backwards to lift up rear end of the top cover.
- 2 Slide out the top cover (mind the wing on either side of the cover).
- 3 Punch holes in labeled area between the two rails on the rear of the top for conduits (not supplied) as required. Line hole(s) with grommets (not supplied) Reinstall the top plate.

2 AC Input and Ground Cable Landings

Bottom cable entry

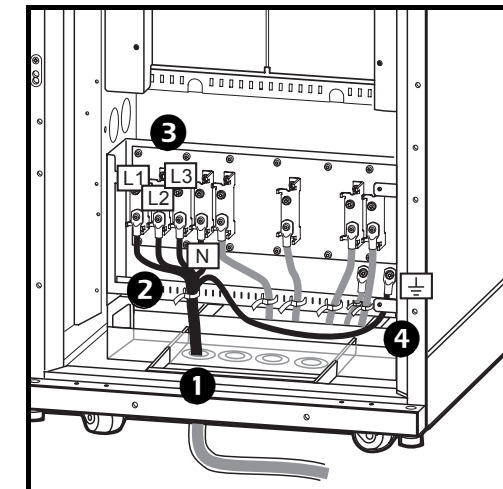

- 1 Feed the input cables in conduits (not supplied) through the punched holes in the bottom plate.
- 2 Use cable ties to attach the cables to the slotted plate.
- 3 Connect the input cables (L1, L2, L3), and N to the cable landings.
- 4 Connect the ground cable using the provided screw (earth symbol beneath the applicable screw).
- 5 Reinstall bottom cable landing cover.



Top cable entry

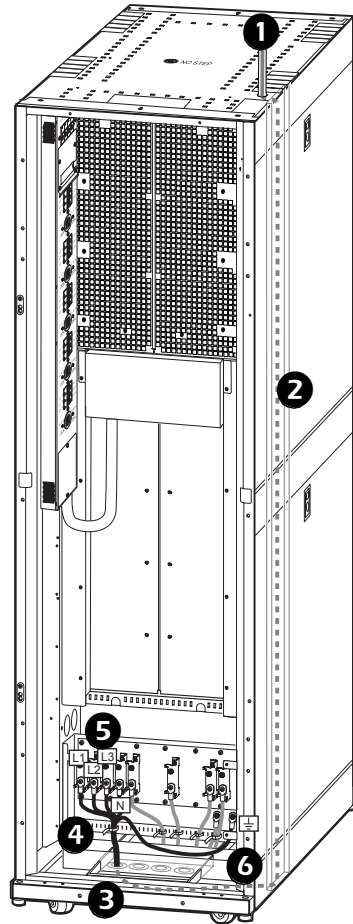

- 1 Feed the input cables in conduits (not supplied) through the punched holes.
- 2 Run the cables in the side panel.
- 3 Guide the input cables through the punched holes in the bottom plate up to the cable landing.
- 4 Use cable ties to attach the cables to the slotted plate.
- 5 Connect the input cables (L1, L2, L3), and N to the cable landings.
- 6 Connect the ground cable using the provided screw (earth symbol beneath applicable screw).
- 7 Reinstall bottom cable landing cover.

- 3 Feed the cables through the conduit box.
- 4 Use cable ties to attach the cable to the slotted plate.
- 5 Connect the battery cables Bat+ and Bat- and the N cable in the designated areas.

Top cable entry

See how to punch holes in the top cover in section 1:
Preparing for top cable entry.

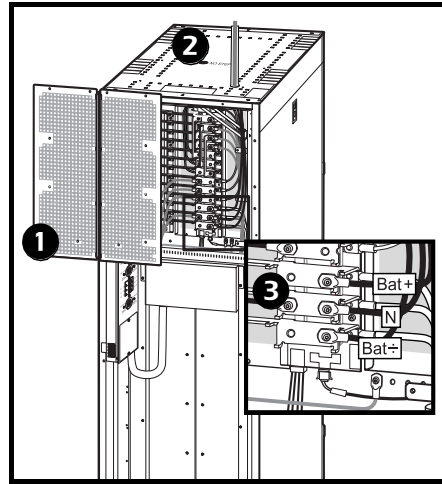

- 1 Use a torx screwdriver to remove top cable landing covers..
- 2 Guide the cables through the punched hole in the top cover and down to the cable landings.
- 3 Connect Bat+ and Bat- and N in the designated areas.

4 Connecting Load to the PDU

Preparing to connect the load to the PDU(s)

Note Connect the load equipment evenly between the 3 phases to avoid overloading the PDU. The total output capacity of the PDU is approximately twice the output capability of the UPS. This means that UPS would be over-loaded if all PDU outlets were loaded to their rating. Load status on the individual phases can be found through the UPS display or through the web interface.

Note Equipment connected to the 3-phased output may require overcurrent protection with a lower rating than the 3-phased output.

Note For 3-phased 4-pole output the highest current may be in the Neutral conductor at non-linear loads (up to 173%).

Connecting load to the 4-pole breaker

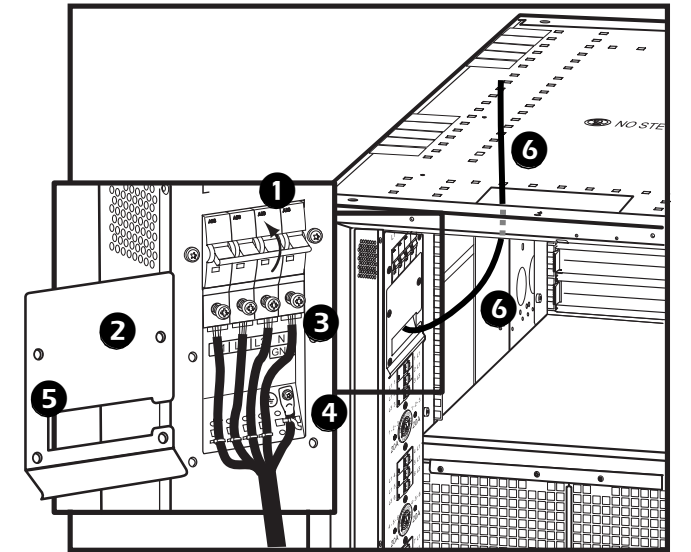

- 1 Set the top PDU breaker to the OFF position.
- 2 Using a torx screwdriver, remove the four M4 screws from the top plate of PDU. Remove plate.
- 3 Connect the L1, L2, L3, N to the terminals and tighten the M6 screws firmly. Fasten cables with cable ties.
- 4 Attach the ground cable to the ground stud (labeled earth) and fasten with cable tie.
- 5 Use a torx screwdriver to reinstall the top plate removed in step 2.
- 6 Feed the cable through the hole in the top cover.

Connecting load to the 3-pole breaker(s)

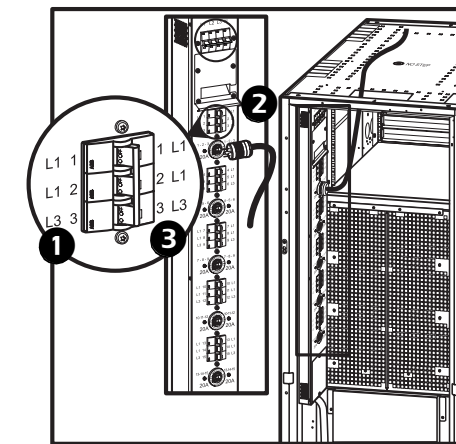

- 1 Set the applicable breaker to the OFF position.
- 2 Insert the plug from the load into the receptacle. Secure the plug by turning it clockwise approximately 30°.
- 3 Set the applicable breaker to the ON position to supply the load.

3 Battery Cable Landings

Note The UPS may ONLY be connected to the APC SUVTBXR Battery Enclosure.

Bottom cable entry

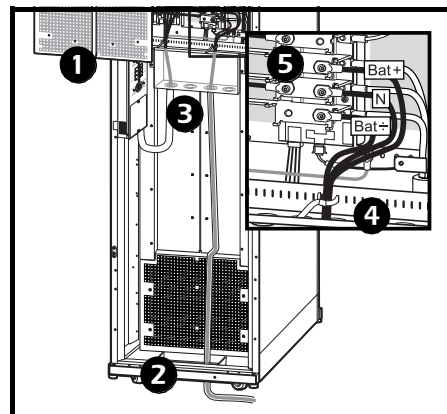

- 1 Use a torx screwdriver to remove top cable landing covers.
- 2 Feed the battery cable through the bottom of the UPS. On the outside of the bottom cover, run the cable in conduits (not provided) to the conduit box.
- 3
- 4

Disconnecting the load from the PDU(s)

To disconnect the load, set the applicable breaker to the OFF position.

PDU output breaker ratings

Rear of unit	Ambient temperature in front of unit °C	Nominal rating of breaker		
		20	50	63
Free exhaust	20	17	42.5	53.55
Free exhaust	30	16	40.0	50.40
Free exhaust	40	15	37.5	47.25
Hot aisle exhaust	25	16	40.0	50.40

5 Communication Cables



Emergency Power Off (EPO) switch must be connected to a NEC Class 2 circuit.



Use only 28-16 AWG copper wire for the connection of the EPO switch and other optional equipment. Keep all other wiring and uninsulated live parts separate of other NEC Class 2 circuits.



Do not connect any circuits to the EPO terminal block unless it can be confirmed that the circuit is a NEC Class 2 circuit.



Remove top cable landing covers as described under Battery Cable Landings, top entry.

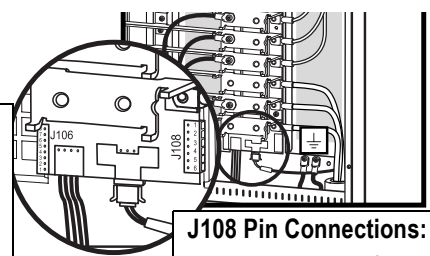

J106 Pin Connections:

- 8 Ext. charging control return
- 7 External control of charging
- 6 Q3 active return
- 5 Q3 active
- 4 Battery measurement supply*
- 3 Battery unit quantity*
- 2 Max. battery temperature*
- 1 Battery measurement return*

* Should be used with APC XR Enclosures

J108 Pin Connections:

- 1 Normally open EPO
- 2 Normally open EPO return
- 3 Normally closed EPO
- 4 Normally closed EPO return
- 5 +24V SELV supply
- 6 SELV ground



The UPS must be connected to either a dry contact or a 24 V_{DC} EPO switch.



Always follow the pin connection procedures from the top and work down: J106 (8-1), J108 (1-6).

EPO (Emergency Power Off) switch wiring – pin connections J108 (for EPO wiring options)

Connect the EPO cable, using one of the following 4 wiring configurations:

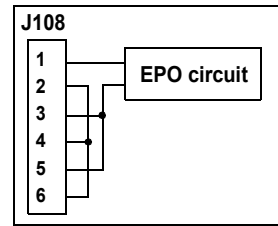

1: Dry Contracts Normally Open

EPO is activated when pin 1 is connected to pins 3 and 5.
Prewired connection 2-4-6, 3-5 and 1 =>

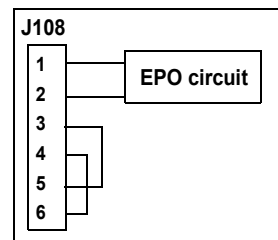

2: +24V Normally Open

EPO is activated when an isolated SELV 24V_{DC} voltage is supplied on pin 1 with reference to pin 2.
Prewired connection 3-5 and 4-6

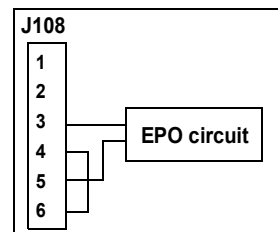

3: Dry Contracts Normally Closed

EPO is activated when a connection from pin 3 to pin 5 is opened.
Prewired connection 4-6.

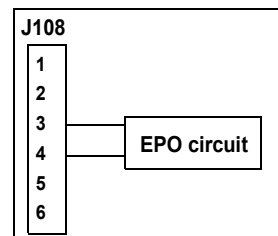

4: +24V Normally Closed

EPO is activated when a SELV 24V_{DC} voltage removed from pin 3 with reference to pin 4.

Pin connections J106 (UPS)

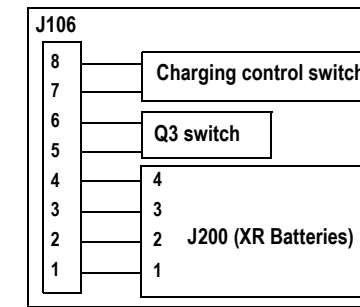

Pins 1 to 4 are for battery measurement (only applicable to APC XR Battery Enclosures).

Pins 5 and 6 are for external maintenance bypass Q3 (auxiliary switch N/C type). When Q3 is closed, signals are fed back to the UPS controller.

Pins 7 and 8 are for external charge control. When 7 and 8 are closed, the UPS charges batteries with a pre-defined percentage (0-25-50-75-100%) of the maximum charging power. To be used in generator applications, or if special codes requires control of charging. When Q3 is closed, signals are fed back to the UPS controller.



When connecting the Q3 auxiliary signal, use gold-plated N/C auxiliary switch on Q3.



Reinstall cable landing covers.

Connection of APC communication options – PowerChute software and temperature sensor (identical cable routing)

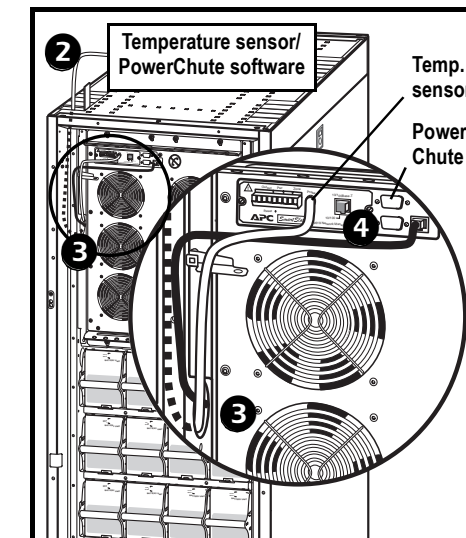

1 Open front door.

2 Feed cables from optional communication equipment through the opening in the top cover.

3 Guide the cables along the inside of the left side panel down to the opening in the power module frame.

4 Connect communication equipment where shown.



The APC communication options are provided at the front of the UPS.

6 UPS Specifications

UPS ratings	20 kVA		30 kVA	
	208 V	220 V	208 V	220 V
Input voltage / Bypass voltage (V) per phase	208	220	208	220
Input current (nominal) (A)	54.2	51.2	83.1	76.9
Input frequency (Hz)	60	60	60	60
Output voltage (on line) (Vac) Minimum and maximum values (±1%)	3x208	3x220	3x208	3x220
Output current (nominal, per phase) (A)	55.5	52.5	83.3	78.7
Maximum output current (in bypass only at 110% overload per phase)	61.1	57.7	91.6	86.6
Neutral output current (with 100% switch mode load) (A)	96.2	90.9	144.2	136.4

Minimum breaker settings

20kVA	Internal fault	800% overload bypass operation	150% overload normal/battery operation	125% overload normal/battery operation	Continuously
Mains input	4 kA	–	–	–	68 A
Bypass input	2.3 kA	444 A	–	–	62 A
Duration	<10 ms	500 ms	30 s	60 s	∞
Notes	1				

30kVA	Internal fault	800% overload bypass operation	150% overload normal/battery operation	125% overload normal/battery operation	Continuously
Mains input	5 kA	–	–	–	102 A
Bypass input	4.2 kA	444 A	–	–	92 A
Duration	<10 ms	500 ms	30 s	60 s	∞
Notes	1				

Note 1: the short-circuit level is indicated for the output value.

Recommended phase-conductor sizes [AWG] for a 86°F (30°C) temperature environment

UPS/AWG sizes	AC input [AWG]	AC output [AWG]	DC input [AWG], 75°C Wire
20 kVA	4	4	4
30 kVA	1	1	1



Use Molex lug type or equivalent, and crimp to manufacturer's specifications.

Cable Size [AWG]	Cable Lug Type	Crimping Tool	Die	Terminal Bolt Diameter
6	YA6CL2TC38	MD7-34R	W5CVT	0.2 in/6 mm
4	YA4CL2TC38	MD7-34R	W4CVT	0.2 in/6 mm
1	YA1CL2TC38	MD7-34R	W1CVT	0.2 in/6 mm



At 100% non-linear load (EN50091-3 standard), the neutral shall be rated for 173% phase current.

Recommended current protection

To ensure the correct functionality of the PDU and to avoid unintentional tripping of the bypass input protection device follow the following recommendation:

Use the SUVTOPT112 (20kVA version) or the SUVT113 (30kVA version) as input protection.

Output protection is included in the PDU of the unit.

Note: Using a solution solely based on breakers, selectivity for load short circuit currents higher than 2 kA cannot be assured for the 3-phased output. If this is required, use fuses to protect the bypass.

UPS size	Fuse type
20 kVA version 208 V input voltage	100 A Class J time delay fuse
30 kVA version 208 V input voltage	125 A Class J time delay fuse

If fuses are preferred, the following can be used:

UPS size	Breaker/fuse
20 kVA version 208 V input voltage	100 A
30 kVA version 208 V input voltage	125 A

Ensure that the short-circuit current on the UPS input is less than 14 kA_{iC} sym RMS. Also take into consideration the below breaker settings to ensure correct functionality during overload operation.



Breakers/fuses other than APC SUVTOPT need complete selectivity assessments.

7 Checklist

- Do not apply electricity to the UPS.
- Do not connect batteries in the UPS.
- If an XR Battery Enclosure is installed make sure that the DC breaker (if available) is in the OFF position and that both 125A fuses are removed from the XR Battery Enclosure.
- Check that the power wiring is torqued to 62 lbf in/7 Nm.
- Verify clockwise phase-rotation (L1, L2, L3) and make sure a neutral connection is present.
- If the installation includes an XR Battery Enclosure, remount the 125A fuses in the XR Battery Enclosure and check that the DC breaker (if available) on the XR Battery Enclosure is in the ON position.
- Leave a wiring diagram on site for service personnel.
- Close the rear door.
- For any optional equipment, refer to product-specific manuals.

8 Contact Information

If a problem occurs, phone Customer Support at (1) (800) 800-4272 (US and Canada). For country-specific centers: go to www.apc.com/support/ contact. Web Support: write to support@apc.com.