



VarSet

Catalog 2018
Low Voltage Capacitor Banks
North America



schneider-electric.com

Life Is On

Schneider
Electric

Your requirements...



Optimize energy consumption

- By reducing electricity bills,
- By reducing power losses,
- By reducing CO₂ emissions.



Increase power availability

- Compensate for voltage sags detrimental to process operation,
- Avoid nuisance tripping and supply interruptions..



Improve your business performance

- Optimize installation size,
- Reduce harmonic distortion to avoid the premature ageing of equipment and destruction of sensitive components.

Our solutions...

Reactive energy management

In electrical networks, reactive energy results in increased line currents for a given active energy transmitted to loads.

The main consequences are:

- Need for oversizing of transmission and distribution networks by utilities,
- Increased voltage drops and sags along the distribution lines,
- Additional power losses.

This results in increased electricity bills for industrial customers because of:

- Penalties applied by most utilities on reactive energy,
- Increased overall kVA demand,
- Increased energy consumption within the installations.

Reactive energy management aims to optimize your electrical installation by reducing energy consumption, and to improve power availability. Total CO₂ emissions are also reduced.

Utility power bills are typically reduced by 5% to 10%*.



"Our energy consumption was reduced by **9%** after we installed 10 capacitor banks with detuned reactors. Electricity bill optimised by 8% and payback in 2 years."

Testifies Michelin Automotive in France.

"Energy consumption reduced by **5%** with LV capacitor bank and active filter installed."

POMA OTIS Railways, Switzerland.

"70 capacitor banks with detuned reactors installed, energy consumption reduced by 10%, electricity bill optimised by 18%, payback in just

1 year."

Madrid Barajas airport Spain.

"Our network performance improved significantly after we installed 225 LV Detuned capacitor banks. The capacitor banks incorporates advanced metering system and remote communication ensures continued operation and minimal down time."

Ministry of Electricity and Water, Kuwait.

* Performance reflects actual customer experience, your results may vary depending on your environment.

Improve electrical networks and reduce energy costs

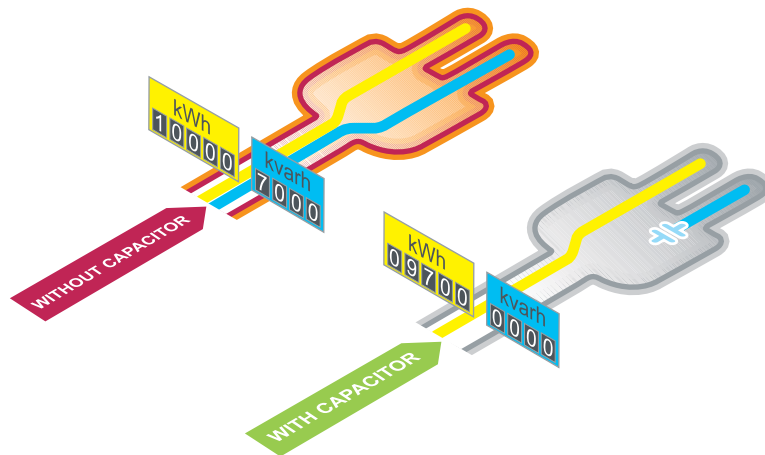

Power Factor Correction

Every electric machine needs active power (kW) and reactive power (kVAr) to operate.

- The power rating of the installation in kVA is the combination of both:
 $(kVA)^2 = (kW)^2 + (kVAr)^2$
- The Power Factor has been defined as the ratio of active power (kW) to apparent power (kVA).
 $\text{Power Factor} = (kW) / (kVA)$



The objective of Reactive Energy management is improvement of Power Factor, or "Power Factor Correction".

This is typically achieved by producing reactive energy close to the consuming loads, through connection of capacitor banks to the network.

Ensure **reliability** and **safety** on installations

+ Quality and reliability

- Continuity of service thanks to the high performance and long life expectancy of capacitors.
- 100% testing in manufacturing plant.
- Design and engineering with the highest international standards.



+ Safety

- Over-pressure system for safe disconnection at the end of life.
- All materials and components are free of PCB pollutants.



+ Efficiency and productivity

- Product development including innovation in ergonomics and ease of installation and connection.
- Specially designed components to save time on installation and maintenance.
- All components and solutions available through a network of distributors and partners in more than 100 countries.



Thanks to the know-how developed over 50 years, Schneider Electric ranks as the global specialist in Energy management providing a unique and comprehensive portfolio.

Schneider Electric helps you to make the most of your energy with innovative, reliable and safe solutions.



Quality & Environment



Quality certified ISO9001, ISO14001 and ISO50001

A major strength

In each of its units, Schneider Electric has an operating organization whose main role is to verify quality and ensure compliance with standards. This procedure is:

- uniform for all departments;
- recognized by numerous customers and official organizations.

But, above all, its strict application has made it possible to obtain the recognition of independent organizations.

The quality system for design and manufacturing is certified in compliance with the requirements of the ISO 9001 and ISO 14001 Quality Assurance model.



Stringent, systematic controls

During its manufacture, each equipment item undergoes systematic routine tests to verify its quality and compliance:

- dielectric testing;
- earth connection continuity test;
- functional test of probes & ventilation;
- functional test of the PFC system;
- verification of protection settings;
- verification of compliance with drawings and diagrams.

The results obtained are recorded and initialled by the Quality Control Department on the specific test certificate for each device.



Schneider Electric undertakes to reduce the energy bill and CO₂ emissions of its customers by proposing products, solutions and services which fit in with all levels of the energy value chain.

The Power Factor Correction and harmonic filtering offer form part of the energy efficiency approach.



Energy Efficiency



Immediate Savings*

* Assuming the Power Factor correction equipment is properly chosen, installed, connected and commissioned.

General contents

VarSet

Power Factor correction Guidelines

Why reactive energy management?
Method for determining compensation
Typical solutions depending on applications

A

VarSet offer

Overview
Selection guide
VarSet Standard
VarSet Detuned
VarSet Fast
VarSet accessories
Construction of references
Typical dimensions

B

Appendix

Power factor of most common receiving devices
When should fixed power factor correction be used?
Automatic compensation: installation advice
General information about harmonics
Causes and effects of harmonics
VarPlus Logic series
Calculation of reactive power

C

Power Factor correction Guidelines

Power Factor correction Guidelines

Why reactive energy management?	12
Method for determining compensation	14
Typical solutions depending on applications	19



Other chapters	
VarSet offer	20
Appendix	38

Why reactive energy management?

A

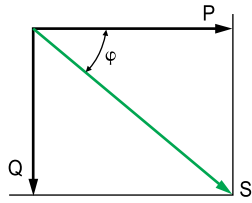

Fig. 1 In this representation, the Power Factor (P/S) is equal to $\cos \phi$.

- Due to this higher supplied current, the circulation of reactive energy in distribution networks results in:
- Overload of transformers
 - Higher temperature rise in power cables
 - Additional losses
 - Large voltage drops
 - Higher energy consumption and cost
 - Less distributed active power

Principle of reactive energy management

All AC electrical networks consume two types of power: active power (kW) and reactive power (kVAR):

- **The active power P** (in kW) is the real power transmitted to loads such as motors, lamps, heaters, computers, etc. The electrical active power is transformed into mechanical power, heat or light.
- **The reactive power Q** (in kVAR) is used only to power the magnetic circuits of machines, motors and transformers.

The apparent power S (in kVA) is the vector combination of active and reactive power.

The circulation of reactive power in the electrical network has major technical and economic consequences. For the same active power P, a higher reactive power means a higher apparent power, and thus a higher current must be supplied.

The circulation of active power over time results in active energy (in kWh). The circulation of reactive power over time results in reactive energy (kvarh).

In an electrical circuit, the reactive energy is supplied in addition to the active energy.

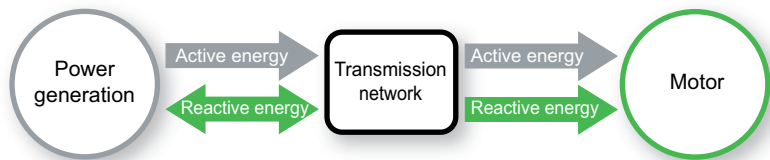

Fig. 2 Reactive energy supplied and billed by the energy provider.

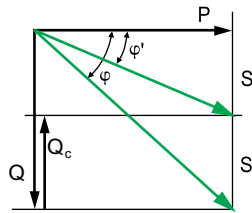

Fig. 4

For these reasons, there is a great advantage in generating reactive energy at the load level in order to prevent the unnecessary circulation of current in the network. This is what is known as "power factor correction". This is obtained by the connection of capacitors, which produce reactive energy in opposition to the energy absorbed by loads such as motors.

The result is a reduced apparent power, and an improved power factor P/S' as illustrated in the diagram opposite.

The power generation and transmission networks are partially relieved, reducing power losses and making additional transmission capacity available.

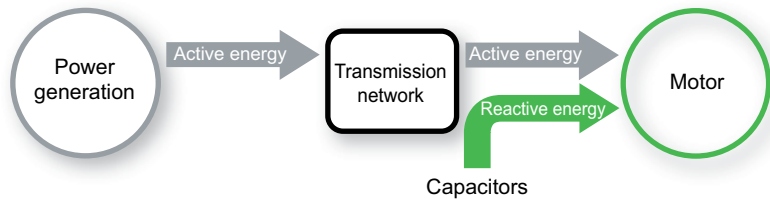

Fig. 3 The reactive power is supplied by capacitors. No billing of reactive power by the energy supplier



Benefits of reactive energy management

Optimized reactive energy management brings economic and technical advantages as follows:

Savings on utility bill

- Eliminating penalties on reactive energy and decreasing kW / kVA.
- Reducing power losses generated in the transformers and conductors of the installation.

Example:

Loss reduction in a 630 kVA transformer PW = 6,500 W with an initial Power Factor = 0.7. With power factor correction, we obtain a final Power Factor = 0.98. The losses become: 3,316 W, i.e. a reduction of 49%.

Increasing service capacity

A high power factor optimizes an electrical installation by allowing better use of the components. The power available at the secondary of a MV/LV transformer can therefore be increased by fitting power factor correction equipment on the low voltage side.

The table opposite shows the increased available power at the transformer output through improvement of the Power Factor from 0.7 to 1.

Power factor	Increased available power
0.7	0%
0.8	+ 14%
0.85	+ 21%
0.90	+ 28%
0.95	+ 36%
1	+ 43%

Reducing installation cost

Installing power factor correction equipment allows conductor cross-section to be reduced, since less current is absorbed by the compensated installation for the same active power.

The opposite table shows the multiplying factor for the conductor cross-section with different power factor values.

Power factor	Cable cross-section multiplying factor
1	1
0.80	1.25
0.60	1.67
0.40	2.50

Improved voltage regulation

Installing capacitors allows voltage drops to be reduced upstream of the point where the power factor correction device is connected.

This prevents overloading of the network and reduces harmonics, so that you will not have to overrate your installation.

Method for determining compensation

A

The selection of Power Factor Correction equipment should follow the following 4-step process and must be done by any people having the relevant skills:

- Step 1: Calculation of the required reactive power.
- Step 2: Selection of the compensation mode:
 - Central, for the complete installation
 - By sector
 - For individual loads, such as large motors.
- Step 3: Selection of the compensation type:
 - Fixed, by connection of a fixed-value capacitor bank;
 - Automatic, by connection of a different number of steps, allowing adjustment of the reactive energy to the required value;
 - Dynamic, for compensation of highly fluctuating loads.
- Step 4: Allowance for operating conditions and harmonics.

Step 1: Calculation of the required reactive power

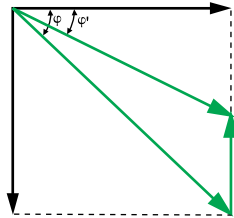

Fig. 5

The objective is to determine the required reactive power Q_c (kvar) to be installed, in order to improve the power factor $\cos \varphi$ and reduce the apparent power S .

For $\varphi' < \varphi$, we obtain: $\cos \varphi' > \cos \varphi$ and $\tan \varphi' < \tan \varphi$.

This is illustrated in the diagram opposite.

Q_c can be determined from the formula (see Fig. 5):

$$Q_c = P \cdot (\tan \varphi - \tan \varphi')$$

where:

Q_c = power of the capacitor bank in kVAr.

P = active power of the load in kW.

$\tan \varphi$ = tangent of phase shift angle before compensation.

$\tan \varphi'$ = tangent of phase shift angle after compensation.

The parameters φ and $\tan \varphi$ can be obtained from billing data, or from direct measurement in the installation.

The following table can be used for direct determination.

Before compensation		Reactive power (kvar) to be installed per kW of load, in order to get the required $\cos \varphi'$ or $\tan \varphi'$							
		$\tan \varphi'$	0.75	0.62	0.48	0.41	0.33	0.23	0.00
		$\cos \varphi'$	0.80	0.85	0.90	0.925	0.95	0.975	1.000
$\tan \varphi$	$\cos \varphi$								
1.73	0.5		0.98	1.11	1.25	1.32	1.40	1.50	1.73
1.02	0.70		0.27	0.40	0.54	0.61	0.69	0.79	1.02
0.96	0.72		0.21	0.34	0.48	0.55	0.64	0.74	0.96
0.91	0.74		0.16	0.29	0.42	0.50	0.58	0.68	0.91
0.86	0.76		0.11	0.24	0.37	0.44	0.53	0.63	0.86
0.80	0.78		0.05	0.18	0.32	0.39	0.47	0.57	0.80
0.75	0.80			0.13	0.27	0.34	0.42	0.52	0.75
0.70	0.82			0.08	0.21	0.29	0.37	0.47	0.70
0.65	0.84			0.03	0.16	0.24	0.32	0.42	0.65
0.59	0.86				0.11	0.18	0.26	0.37	0.59
0.54	0.88				0.06	0.13	0.21	0.31	0.54
0.48	0.90					0.07	0.16	0.26	0.48

Example:

consider a 1000 kW motor with $\cos \varphi = 0.8$ ($\tan \varphi = 0.75$).

In order to obtain $\cos \varphi = 0.95$, it is necessary to install a capacitor bank with a reactive power equal to $k \times P$, i.e.: $Q_c = 0.42 \times 1000 = 420$ kvar.

Power Factor correction Guidelines

Method for determining compensation

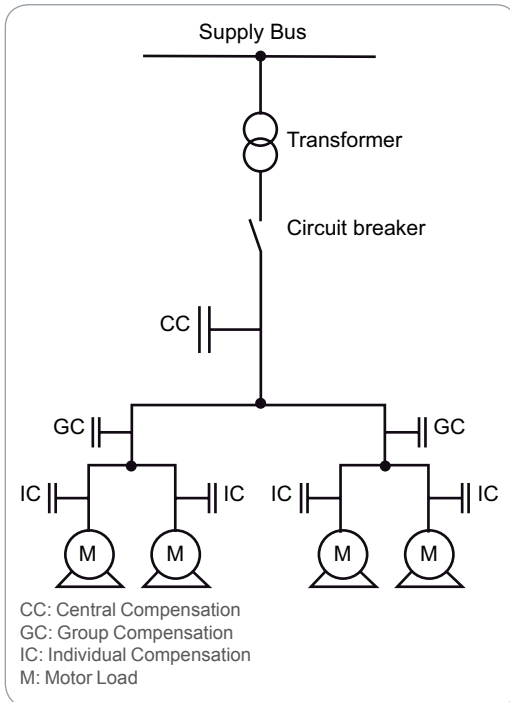

Fig. 6

Step 2: Selection of the compensation mode

The location of low-voltage capacitors in an installation constitutes the mode of compensation, which may be central (one location for the entire installation), by sector (section-by-section), at load level, or some combination of the latter two. In principle, the ideal compensation is applied at a point of consumption and at the level required at any moment in time.

In practice, technical and economic factors govern the choice.

The location for connection of capacitor banks in the electrical network is determined by:

- the overall objective (avoid penalties on reactive energy relieve transformer or cables, avoid voltage drops and sags)
- the operating mode (stable or fluctuating loads)
- the foreseeable influence of capacitors on the network characteristics
- the installation cost.

Central compensation

The capacitor bank is connected at the head of the installation to be compensated in order to provide reactive energy for the whole installation.

This configuration is convenient for a stable and continuous load factor.

Group compensation (by sector)

The capacitor bank is connected at the head of the feeders supplying one particular sector to be compensated. This configuration is convenient for a large installation, with workshops having different load factors.

Compensation of individual loads

The capacitor bank is connected right at the inductive load terminals (especially large motors). This configuration is very appropriate when the load power is significant compared to the subscribed power.

This is the ideal technical configuration, as the reactive energy is produced exactly where it is needed, and adjusted to the demand.

Method for determining compensation

A

Step 3: Selection of the compensation type

Different types of compensation should be adopted depending on the performance requirements and complexity of control:

- Fixed, by connection of a fixed-value capacitor bank
- Automatic, by connection of a different number of steps, allowing adjustment of the reactive energy to the required value
- Dynamic, for compensation of highly fluctuating loads.

Fixed compensation

This arrangement uses one or more capacitor(s) to provide a constant level of compensation. Control may be:

- Manual: by circuit-breaker or load-break switch
- Semi-automatic: by contactor
- Direct connection to an appliance and switched with it.

These capacitors are installed:

- At the terminals of inductive loads (mainly motors)
- At busbars supplying numerous small motors and inductive appliances for which individual compensation would be too costly
- In cases where the load factor is reasonably constant.

Automatic compensation

This kind of compensation provides automatic control and adapts the quantity of reactive power to the variations of the installation in order to maintain the targeted $\cos \phi$. The equipment is installed at points in an installation where the active-power and/or reactive-power variations are relatively large, for example:

- on the busbars of a main distribution switchboard
- on the terminals of a heavily-loaded feeder cable.

Where the kvar rating of the capacitors is less than or equal to 15% of the power supply transformer rating, a fixed value of compensation is appropriate. Above the 15% level, it is advisable to install an automatically-controlled capacitor bank.

Control is usually provided by an electronic device (Power Factor Controller) which monitors the actual power factor and orders the connection or disconnection of capacitors in order to obtain the targeted power factor. The reactive energy is thus controlled by steps. In addition, the Power Factor Controller provides information on the network characteristics (voltage amplitude and distortion, power factor, actual active and reactive power...) and equipment status. Alarm signals are transmitted in case of malfunction.

Connection is usually provided by contactors. For compensation of highly fluctuating loads, the use of active filters or Electronic Var Compensators (EVC) is recommended. Contact Schneider Electric for electronic compensation solutions.

Dynamic compensation

This kind of compensation is required when fluctuating loads are present, and voltage fluctuations have to be prevented. The principle of dynamic compensation is to associate a fixed capacitor bank and an electronic var compensator, providing either leading or lagging reactive currents.

The result is continuously varying fast compensation, perfectly suitable for loads such as lifts, crushers, spot welding, etc.

Power Factor correction Guidelines

Method for determining compensation

Step 4: Allowance for operating conditions and harmonics

Capacitor banks should be selected depending on the working conditions expected during their lifetime.

Allowing for operating conditions

The operating conditions have a great influence on the life expectancy of capacitors. The following parameters should be taken into account:

- Ambient Temperature (°C)
- Expected over-current, related to voltage disturbances, including maximum sustained overvoltage
- Maximum number of switching operations/year
- Required life expectancy.

Our Power Factor Correction equipment are not suitable for a use in an environment with an explosive atmosphere (ATEX).

Choice of compensation type

Devices using power electronics (variable speed drives, rectifiers, UPSs, arc furnaces, fluorescent lamps, etc.) generate harmonic currents in electrical networks.

Such harmonics can interfere with the operation of many devices, including capacitors, which are highly sensitive to harmonics. A high level of harmonic pollution causes capacitors to overheat and age prematurely (breakdown).

Different types of compensation must be chosen according to the power of the harmonic generators: standard or detuned. They can be selected as shown on the following page.

A

Power Factor correction Guidelines

Method for determining compensation

A

Choice of compensation type (cont'd)

The chart below indicates the standard or detuned compensation choices.

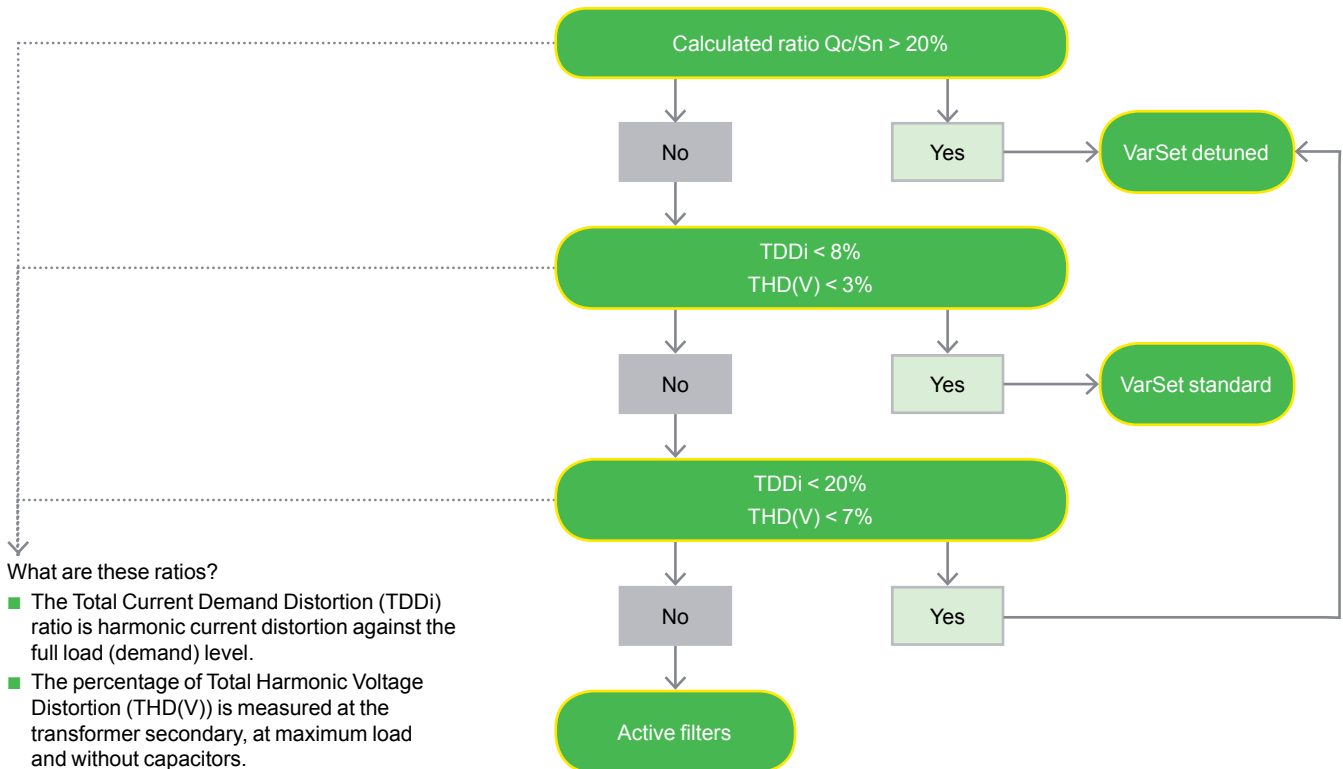

What are these ratios?

- The Total Current Demand Distortion (TDDi) ratio is harmonic current distortion against the full load (demand) level.
- The percentage of Total Harmonic Voltage Distortion (THD(V)) is measured at the transformer secondary, at maximum load and without capacitors.

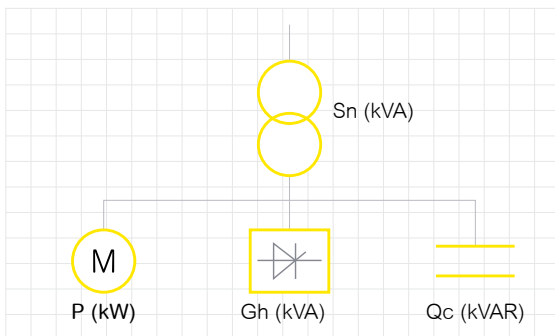

- S_n : apparent power of the transformer
- G_h : apparent power of harmonics-generating receivers (variable speed motors, static converters, power electronics, etc.)
- Q_c : power of the compensation equipment
- V : network voltage

Power Factor correction Guidelines

Typical solutions depending on applications



Customer requirements

The table below shows the solutions most frequently used in different types of applications.

- Very frequently
- Usually
- Occasionally

In all cases, it is strongly recommended that measurements be carried out on site in order to validate the solution.

Types of applications	VarSet Standard	VarSet Detuned	VarSet Fast
Industry			
Food and drink		Very frequently	
Textiles		Usually	
Wood		Usually	
Paper		Occasionally	
Printing		Usually	
Chemicals - pharmaceuticals		Usually	
Plastics		Usually	
Glass - ceramics		Usually	
Steel production		Usually	
Metallurgy		Usually	Occasionally
Automotive		Very frequently	Usually
Cement works		Usually	
Mining		Usually	Occasionally
Refineries		Usually	
Microelectronics		Usually	Usually
Tertiary			
Banks - insurance		Very frequently	
Supermarkets		Very frequently	
Hospitals		Occasionally	Very frequently
Stadiums		Very frequently	Occasionally
Amusement parks		Occasionally	Very frequently
Hotels - offices		Very frequently	
Energy and infrastructure			
Substations	Usually		
Water distribution		Very frequently	
Internet		Very frequently	
Railway transport		Very frequently	Occasionally
Airports		Very frequently	Occasionally
Underground train systems		Very frequently	Occasionally
Bridges		Very frequently	
Tunnels		Usually	
Wind turbines		Very frequently	Occasionally

VarSet offer

VarSet offer

Overview	22
Selection guide.....	24
VarSet standard.....	26
VarSet detuned.....	28
VarSet Fast.....	32
VarSet accessories.....	34
Construction of references.....	35
Typical dimensions.....	36



Other chapters	
Power Factor correction Guidelines	10
Appendix	38

VarSet

ISO 9001
Quality certified manufacturing
ISO 14001
Environmental management system



Non contractual picture



B

The entire VarSet range offers a unique combination of abilities to give you more convenience, reliability and performance across a broad range of applications.

Forward-thinking design and meticulous manufacturing quality means you can count on VarSet capacitor banks to deliver dependable, long-term service.

Embedded communication features will allow you to optimize surveillance, maintenance and performance of your capacitor bank asset.

EcoStruxure™
Innovation At Every Level

EcoStruxure™ Power ready

- Seamless integration thanks to embedded Modbus communication
- Remote equipment follow up & control
- Remote troubleshooting
- Enable analytics & mobile benefits of EcoStruxure™ Power



Safety

> Protection

- overload protection for each stage
- short-circuit protection for each stage
- thermal monitoring device
- 3 phase overPressure Disconnection System on each capacitor

> Robust Enclosure System

- NEMA 1 for indoor application
- high quality welding and painting
- protection against mechanical shocks

> Tested and certified

- fully type tested and certified to CSA 22.2 No. 190 and to UL 810

Reliability

> Long-life performance

- Schneider capacitor engineered for harsh environment and long life*
- multi level and redundancy of protections
- reduced switching inrush current thanks to special design contactor or detuned reactors
- integration of high quality Schneider components

> Easy maintenance

- automatic step size detection
- self diagnosis of capacitor output & derating
- alarm functions available (temperature, Harmonics, Voltage, Overload , hunting...)

Performance

> Easy installation & commissioning

- automatic step size detection
- current transformer polarity auto-detection

> Advanced measurement and monitoring functions

- real time step monitoring (remaining power, number of switches)
- harmonic control till the 19th harmonic
- 4 quadrant operations
- overload assessment thru harmonics

> Future-ready : "Connectable product"

* Cf. Low voltage components catalog PFCED310003EN



Compensation type

■ Automatic compensation:

This compensation type is used for unstable loads.

The VarSet LV equipment will automatically adjust the reactive power according to variations in load and/or power factor. Schneider Electric recommends the use

of automatic compensation when the capacitor bank's power is more than 15% of the power of the transformer, in order to avoid overcompensation.

■ Fixed compensation:

This compensation type is used for stable loads, with synchronised voltage and current. The equipment will supply a constant reactive power irrespective of load variations.

Network harmonics

Non-linear loads, such as devices using power electronics, generate harmonics within a network.

The selection of the appropriate power factor correction solution has to be adapted depending on the level of network pollution.

The selection is based on the value of the Gh/Sn ratio, with:

- Gh = total power of the non-linear loads
- Sn = rated power of the supply transformer

The selection can also be made according to the percentage of total harmonic current distortion THDi or total harmonic voltage distortion THDu measured.

The compensation needs of your installation vary depending on factors such as load variation, network harmonic content, and the characteristics of the installation. Find out the right level of compensation for your network with the help of the chart below.

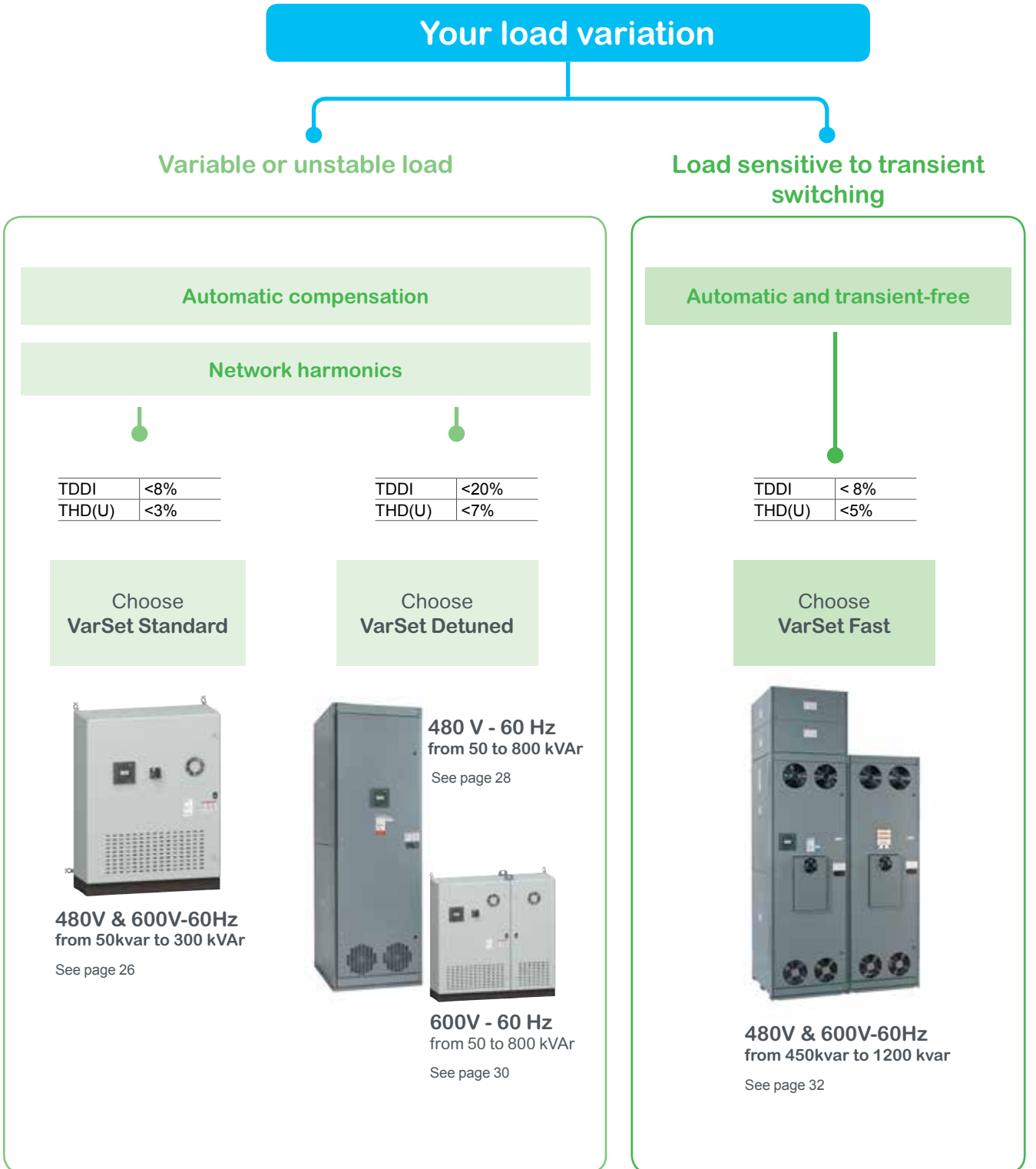

B

VarSet Standard

Network 480 & 600V / 60Hz



B

Environment

- Installation: Indoor
- Ambient temperature: 15 to 104F (-10°C to 40°C)
- Humidity: up to 95%
- Maximum altitude: 6500 feet (2000 m)

Standards

- CSA 22.2 No. 190
- UL810, UL508a

Environment certifications

Produced in 14001 certified plants, product environmental profile available

General characteristics

Electrical Characteristics

Rated Voltage	480V 600V / 60Hz
Capacitance Tolerance	-5%, +10%
Connection type	Three-phase
Power losses	< 2.5 W/kVAr
Maximum permissible over current	1.35 In
Maximum permissible over voltage	1.1 x Un, 8 h every 24 h

Enclosure

Degree of protection	NEMA 1
Colour	RAL 7035
Degree of mechanical resistance	IK10

Controller

VarPlus Logic	VarPlus Logic controller with embedded Modbus communication
---------------	---

Head circuit breaker protection

Without incoming circuit breaker	Lug connection LV PFC Bank must be protected by a circuit breaker or by a fused disconnect on upstream switchboard
With incoming circuit breaker	PowerPact with rotary handle

Step

Capacitors Type	Varplus Can 575V for network voltage 480V VarplusCan 690V for network voltage 600V Maximum over current: 1.8 In 3-phase overpressure protection Discharge resistance 50 V - 1 min
Contactors	Dedicated to capacitor switching
Circuit breaker protection	PowerPact

Temperature control

Double control	By thermostat and by controller
----------------	---------------------------------

Communication

ModBus	RS485
--------	-------

Installation

Customer connection	Top entry
Auxilliary transformer	120V included - no need for additional supply
CT not included (see page 34)	5VA - secondary 1 or 5A To be installed upstream of the load and capacitor bank
GenSet contact	Available for disconnection with generator
Alarm contact	Available for remote warning signal

VarSet offer

VarSet Standard

Network 480 & 600V / 60Hz

Network voltage 480V - 60Hz

References	Power (kVAR)	Smallest step	Resolution	Electrical steps (#)	Physical steps (#)	Breaking Capacity	Main Circuit breaker	Enclosure type	Enclosure size (H x W x D) mm	Max weight (kg/lbs)
With incoming circuit breaker										
VLVAW2N66075AB	75	12.5	12.5 + 25 + 37.5	6	3	65 kA	HLF36150	VLVAW2N	850 x 800 x 400	80 / 175
VLVAW2N66100AB	100	25	25 + 25 + 50	4	3		JLF36200			
VLVAW3N66125AB	125	25	25 + 50 + 50	5	3		LLF36600U31X	VLVAW3N	1200 x 1000 x 400	125 / 275
VLVAW3N66150AB	150	25	25 + 25 + 2x50	6	4		LLF36600U31X			
VLVAW3N66175AB	175	25	25 + 3x50	7	4		LLF36600U31X			
VLVAW3N66200AB	200	25	25 + 25 + 3x50	5	5		LLF36600U31X			
VLVAW3N66225AB	225	25	25 + 4x50	9	5		LLF36600U31X			
VLVAW3N66250AB	250	25	5x50	5	5		LLF36600U31X			
VLVAW3N66275AB	275	25	25 + 5x50	11	6		LLF36600U31X			
VLVAW3N66300AB	300	50	6x50	6	6	LLF36600U31X				

References	Power (kVAR)	Smallest step	Regulation	Electrical steps (#)	Physical steps (#)	Short-time withstand current	Recommended upstream connection	Enclosure type	Enclosure size (H x W x D) mm	Max weight (kg/lbs)
With main lugs										
VLVAW2N66075AA	75	12.5	12.5 + 25 + 37.5	6	3	25 kA / 3 cycles	HLF36150	VLVAW2N	850 x 800 x 400	80 / 175
VLVAW2N66100AA	100	25	25 + 25 + 50	4	3		JLF36200			
VLVAW3N66125AA	125	25	25 + 50 + 50	5	3		LLF36600U31X	VLVAW3N	1200 x 1000 x 400	125 / 275
VLVAW3N66150AA	150	25	25 + 25 + 2x50	6	4		LLF36600U31X			
VLVAW3N66175AA	175	25	25 + 3x50	7	4		LLF36600U31X			
VLVAW3N66200AA	200	25	25 + 25 + 3x50	5	5		LLF36600U31X			
VLVAW3N66225AA	225	25	25 + 4x50	9	5		LLF36600U31X			
VLVAW3N66250AA	250	25	5x50	5	5		LLF36600U31X			
VLVAW3N66275AA	275	25	25 + 5x50	11	6		LLF36600U31X			



Network voltage 600V - 60Hz

References	Power (kVAR)	Smallest step	Resolution	Electrical steps (#)	Physical steps (#)	Breaking Capacity	Main Circuit breaker	Enclosure type	Enclosure size (H x W x D) mm	Max weight (kg/lbs)
With incoming circuit breaker										
VLVAW2N76050AB	50	12.5	12.5+12.5+25	4	3	50 kA	HLF36090	VLVAW2N	850 x 800 x 400	80 / 175
VLVAW2N76075AB	75	12.5	12.5 + 25 + 37.5	6	3		HLF36150			
VLVAW2N76100AB	100	25	25 + 25 + 50	4	3		JLF36200	VLVAW3N	1200 x 1000 x 400	125 / 275
VLVAW3N76125AB	125	25	25 + 50 + 50	5	3		LLF36600U31X			
VLVAW3N76150AB	150	25	25 + 25 + 2x50	6	4		LLF36600U31X			
VLVAW3N76175AB	200	25	25 + 3x50	7	4		LLF36600U31X			
VLVAW3N76200AB	200	25	25 + 25 + 3x50	5	5		LLF36600U31X			
VLVAW3N76225AB	225	25	25 + 4x50	9	5		LLF36600U31X			
VLVAW3N76250AB	250	25	5x50	5	5		LLF36600U31X			

References	Power (kVAR)	Smallest step	Regulation	Electrical steps (#)	Physical steps (#)	Short-time withstand current	Recommended upstream connection	Enclosure type	Enclosure size (H x W x D) mm	Max weight (kg/lbs)
With main lugs										
VLVAW2N76050AA	50	12.6	12.5+12.5+25	4	3	25 kA / 3 cycles	HLF36090	VLVAW2N	850 x 800 x 400	80 / 175
VLVAW2N76075AA	75	12.7	12.5 + 25 + 37.5	6	3		HLF36150			
VLVAW2N76100AA	100	25	25 + 25 + 50	4	3		JLF36200	VLVAW3N	1200 x 1000 x 400	125 / 275
VLVAW3N76125AA	125	25	25 + 50 + 50	5	3		LLF36600U31X			
VLVAW3N76150AA	150	25	25 + 25 + 2x50	6	4		LLF36600U31X			
VLVAW3N76175AA	175	25	25 + 3x50	7	4		LLF36600U31X			
VLVAW3N76200AA	200	25	25 + 25 + 3x50	5	5		LLF36600U31X			
VLVAW3N76225AA	225	25	25 + 4x50	9	5		LLF36600U31X			
VLVAW3N76250AA	250	25	5x50	5	5		LLF36600U31X			

VarSet Detuned

Network voltage 480 V - 60Hz

Tuning order 4.2



Environment

- Installation: Indoor
- Ambient temperature: -5°C to 40°C
- Humidity: up to 95%
- Maximum altitude: 2000 m

Standards

- CSA 22.2 No. 190
- UL810, UL508a

Environment certifications

RoHS compliant, produced in 14001 certified plants, product environmental profile available

General characteristics

Electrical Characteristics

Rated Voltage	480 V - 60 Hz
Capacitance Tolerance	-5%, +10%
Connection type	Three-phase
Power losses	< 6 W/kVAr
Maximum permissible over current	1.3 x In
Maximum permissible over voltage	1.1 x Un, 8 h every 24 h

Enclosure

Degree of protection	NEMA 1
Colour	RAL 7035 (VLV model) / ASA 49 (AV/BV Model)
Degree of mechanical resistance	IK10 for VLV, Sec 43 UL810 for VLV and AV/BV models

Controller

VarPlus Logic	VarPlus Logic controller with embedded Modbus communication
---------------	---

Head circuit breaker protection

Without incoming circuit breaker	Lug connection LV PFC Bank must be protected by a circuit breaker or by a fused disconnecter on upstream switchboard
With incoming circuit breaker	PowerPact with rotary handle

Step

Capacitors Type	Varplus Can 575V for network voltage 480V Maximum overcurrent 1,8xIn 3 ph overpressure disconnection system Discharge resistor 50V - 1mn
Contactors	Dedicated to capacitor switching
Detuned reactor	Varplus DR Overheating protection by thermostat
Circuit breaker protection	PowerPact

Temperature control

Double control	By thermostat and by controller
----------------	---------------------------------

Communication

ModBUS	RS485
--------	-------

Installation

Customer connection	Top Entry
Auxilliary transformer	120V included - no need for additional supply
CT not included (see page 34)	5VA - secondary 1 or 5A To be installed upstream of the load and capacitor bank
GenSet contact	Available for disconnection with generator
Alarm contact	Available for remote warning signal

Options available on request:

- Fixed stages (by controller programming)
- Custom staging ratios
- Other voltages and frequencies
- Outdoor arrangement - built to NEMA 3R (AV/BV models only)
- Bottom cable entry to main lugs (AV models only)
- Bottom cable entry to main breaker (BV models only)

VarSet offer

VarSet Detuned

Network voltage 480 V - 60Hz
Tuning order 4.2

References	Power (kVAr)	Smallest step	Resolution	No. of electrical steps	No. of physical steps	Breaking capacity	Main Circuit breaker	Enclosure type	Enclosure size (H x W x D) mm / in	Max weight (kg/ lb)	
With incoming circuit breaker											
VLVAF4P66075AB	75	25	25 + 50	6	2	65 kA	HLF36125	VLVAF4P	1200 x 1300 x 400 47.2 x 51.2 x 15.7 in	265 / 585	
VLVAF4P66100AB	100	25	25 + 25 + 50	4	3		JLF36175				
VLVAF4P66125AB	125	25	25 + 2x50	5	3		JLF36200				
VLVAF4P66150AB	150	25	25 + 25 + 2x50	6	4		LLF36600U31X				
VLVAF4P66175AB	175	25	25 + 3x50	7	4		LLF36600U31X				
VLVAF4P66200AB	200	50	4x50	5	4		LLF36600U31X				
BV025046CV5F1N	250	50	50 + 2x100	5	3		RKL type	BV 1	2324 x 762 x 915	747 / 650	
BV030046BV5F1N	300	50	50 + 50 + 2x100	6	4		RKL type	Section	91.5 x 30 x 36 in	793 / 1750	
BV035046CV5F2N	350	50	50 + 3x100	7	4		RKL type	BV 2	2324 x 1524 x 91	1110 / 2450	
BV040046AV8F2N	400	100	4x100	4	4		RKL type	Sections	91.5 x 60 x 36 in	1155 / 2550	
BV045046CV5F2N	450	50	50 + 4x100	9	5	RKL type			1223 / 2700		
BV050046AV8F2N	500	100	5x100	5	5	RKL type			1291 / 2850		
BV055046CV5F2N	550	50	50 + 5x100	11	6	RKL type			1359 / 3000		
BV060046AV8F2N	600	100	6x100	6	6	RKL type			1427 / 3150		
BV065046CV5F2N	650	50	50 + 6x100	13	7	RKL type			1495 / 3300		
BV070046AV8F2N	700	100	7x100	7	7	RKL type			1563 / 3450		
BV075046CV5F3N	750	50	50 + 7x100	15	8	RKL type	BV 3	2324 x 2286 x 915	1835 / 4050		
BV080046AV8F3N	800	100	8x100	8	8	RKL type	Sections	91.5 x 90 x 36 in	1903 / 4200		
With main lugs											
VLVAF4P66075AA	75	25	25 + 50	6	2	25 kA / 3 cycles	HLF36125	VLVAF4P	1200 x 1300 x 400 47.2 x 51.2 x 15.7 in	265 / 585	
VLVAF4P66100AA	100	25	25 + 25 + 50	4	3		JLF36175				
VLVAF4P66125AA	125	25	25 + 2x50	5	3		JLF36200				
VLVAF4P66150AA	150	25	25 + 25 + 2x50	6	4		LLF36600U31X				
VLVAF4P66175AA	175	25	25 + 3x50	7	4		LLF36600U31X				
VLVAF4P66200AA	200	50	4x50	5	4		LLF36600U31X				
AV025046CV5F1N	250	50	50 + 2x100	5	3		65 kA / 4 cycles	RKL type	AV 1	2324 x 762 x 915 91.5 x 60 x 36 in	612 / 1350 657 / 1450 725 / 1600 793 / 1750
AV030046BV5F1N	300	50	50 + 50 + 2x100	6	4			RKL type			
AV035046CV5F1N	350	50	50 + 3x100	7	4			RKL type			
AV040046AV8F1N	400	100	4x100	4	4			RKL type			
AV045046CV5F2N	450	50	50 + 4x100	9	5	RKL type		AV 2	2324 x 1524 x 915 91.5 x 60 x 36 in	1132 / 2500 1200 / 2650 1268 / 2800 1336 / 2950 1404 / 3100 1472 / 3250	
AV050046AV8F2N	500	100	5x100	5	5	RKL type					
AV055046CV5F2N	550	50	50 + 5x100	11	6	RKL type					
AV060046AV8F2N	600	100	6x100	6	6	RKL type					
AV065046CV5F2N	650	50	50 + 6x100	13	7	RKL type					
AV070046AV8F2N	700	100	7x100	7	7	RKL type					
AV075046CV5F2N	750	50	50 + 7x100	15	8	RKL type			1540 / 3400		
AV080046AV8F2N	800	100	8x100	8	8	RKL type			1608 / 3550		

B

VarSet Detuned

Network voltage 600 V - 60Hz

Tuning order 4.2



B

Environment

- Installation: Indoor
- Ambient temperature: 15 to 104F (-10 to 40°C)
- Humidity: up to 95%
- Maximum altitude: 6500 feet (2000 m)

Standards

- CSA 22.2 No. 190
- UL810, UL508a

Environment certifications

Produced in 14001 certified plants, product environmental profile available

General characteristics

Electrical Characteristics

Rated Voltage	600V / 60Hz
Capacitance Tolerance	-5% +10%
Connection type	Three-phase
Power losses	< 6 W per kvar
Maximum permissible over current	1.3 x In
Maximum permissible over voltage	1.1 x Un, 8h per 24h

Enclosure

Degree of protection	NEMA 1
Colour	RAL 7035 (VLV model) / ASA 49 (AV/BV Model)
Degree of mechanical resistance	IK10 for VLV, Sec 43 UL810 for VLV and AV/BV models

Controller

VarPlus Logic	VarPlus Logic controller with embedded Modbus communication
---------------	---

Head circuit breaker protection

Without incoming circuit breaker	Lug connection LV PFC Bank must be protected by a circuit breaker or by a fused disconnecter on upstream switchboard
With incoming circuit breaker	PowerPact with rotary handle

Step

Capacitors Type	VarplusCan 690V for network voltage 600V Maximum overcurrent 1,8xIn 3 ph overpressure disconnection system Discharge resistor 50V - 1mn
Contactors	Dedicated to capacitor switching
Detuned reactor	Varplus DR Overheating protection by thermostat
Circuit breaker protection	PowerPact

Temperature control

Double control	By thermostat and controller
----------------	------------------------------

Communication

ModBUS	RS485
--------	-------

Installation

Customer connection	Top entry
Auxilliary transformer	120V included - no need for additional supply
CT not included (see page 34)	5VA - secondary 1 or 5A To be installed upstream of the load and capacitor bank
GenSet contact	Available for disconnection with generator
Alarm contact	Available for remote warning signal

Options available through configurator (see page 30):

- Fixed stages (by controller programming)
- Custom staging ratios
- Other voltages and frequencies
- Outdoor arrangement - build to NEMA 3R (AV/BV models only)
- Bottom cable entry main lugs (AV models)
- Bottom cable entry to main breaker (BV models)

VarSet Detuned

Network voltage 600 V - 60Hz
Tuning order 4.2

References	Power (kVAr)	Smallest step	Resolution	No. of electrical Steps	No. of physical Steps	Breaking Capacity	Main Circuit breaker	Enclosure type	Enclosure size (H x W x D) mm / in	Max weight (kg/lbs)
With incoming circuit breaker										
VLVAF4P76075AB	75	25	25 + 50	6	2	65 kA	HLF36125	VLVAF4P	1200 x 1300 x 400 47.2 x 51.2 x 15.7 in	265 / 585
VLVAF4P76100AB	100	25	25 + 25 + 50	4	3		JLF36175			
VLVAF4P76125AB	125	25	25 + 2x50	5	3		JLF36200			
VLVAF4P76150AB	150	25	25 + 25 + 2x50	6	4		LLF36600U31X			
VLVAF4P76175AB	175	25	25 + 3x50	7	4		LLF36600U31X			
VLVAF4P76200AB	200	50	4x50	5	4		LLF36600U31X			
BV020066BV5G1N	200	50	50 + 50 + 100	4	3	65 kA	RKL type	BV 1 Section	2324 x 762 x 915 91.5 x 30 x 36 in	747 / 1650 747 / 1650 793 / 1750
BV025066CV5G1N	250	50	50 + 2x100	5	3		RKL type			
BV030066BV5G1N	300	50	50 + 50 + 2x100	6	4		RKL type			
BV035066CV5G2N	350	50	50 + 3x100	7	4		RKL type	BV 2 Sections	2324 x 1524 x 915 91.5 x 30 x 36 in	1110 / 2450 1155 / 2550 1223 / 2700
BV040066AV8G2N	400	100	4x100	4	4		RKL type			
BV045066CV5G2N	450	50	50 + 4x100	9	5		RKL type			
BV050066AV8G2N	500	100	5x100	5	5	RKL type	BV 3 Sections	2324 x 2286 x 915 91.5 x 90 x 36 in	1291 / 2850 1359 / 3000 1427 / 3150	
BV055066CV5G2N	550	50	50 + 5x100	11	6	RKL type				
BV060066AV8G2N	600	100	6x100	6	6	RKL type				
BV065066CV5G2N	650	50	50 + 6x100	13	7	RKL type	BV 3 Sections	2324 x 2286 x 915 91.5 x 90 x 36 in	1495 / 3300 1563 / 3450 1835 / 4050	
BV070066AV8G2N	700	100	7x100	7	7	RKL type				
BV075066CV5G3N	750	50	50 + 7x100	15	8	RKL type				
BV080066AV8G3N	800	100	8x100	8	8	RKL type			1903 / 4200	

References	Power (kVAr)	Smallest step	Resolution	No. of electrical Steps	No. of physical Steps	Short-time withstand current Icw	Recommended upstream protection	Enclosure type	Enclosure size (H x W x D)	Max weight (kg)
With main lugs										
VLVAF4P76075AA	75	25	25 + 50	6	2	25 kA / 3 cycles	HLF36125	VLVAF4P	1200 x 1300 x 400 47.2 x 51.2 x 15.7 in	265 / 585
VLVAF4P76100AA	100	25	25 + 25 + 50	4	3		JLF36175			
VLVAF4P76125AA	125	25	25 + 2x50	5	3		JLF36200			
VLVAF4P76150AA	150	25	25 + 25 + 2x50	6	4		LLF36600U31X			
VLVAF4P76175AA	175	25	25 + 3x50	7	4		LLF36600U31X			
VLVAF4P76200AA	200	50	4x50	5	4		LLF36600U31X			
AV020066BV5G1N	200	50	50 + 50 + 100	4	3	65 kA / 4 cycles	RKL type	AV 1 Section	2324 x 762 x 915 91.5 x 30 x 36 in	612 / 585 612 / 585 657 / 1450
AV025066CV5G1N	250	50	50 + 2x100	5	3		RKL type			
AV030066BV5G1N	300	50	50 + 50 + 2x100	6	4		RKL type			
AV035066CV5G1N	350	50	50 + 3x100	7	4		RKL type	AV 2 Sections	2324 x 1524 x 915 91.5 x 60 x 36 in	725 / 1600 793 / 1750 1132 / 2500
AV040066AV8G1N	400	100	4x100	4	4		RKL type			
AV045066CV5G2N	450	50	50 + 4x100	9	5		RKL type			
AV050066AV8G2N	500	100	5x100	5	5	RKL type	AV 2 Sections	2324 x 1524 x 915 91.5 x 60 x 36 in	1200 / 2650 1268 / 2800 1336 / 2950	
AV055066CV5G2N	550	50	50 + 5x100	11	6	RKL type				
AV060066AV8G2N	600	100	6x100	6	6	RKL type				
AV065066CV5G2N	650	50	50 + 6x100	13	7	RKL type	AV 2 Sections	2324 x 1524 x 915 91.5 x 60 x 36 in	1404 / 3100 1472 / 3250 1540 / 3400	
AV070066AV8G2N	700	100	7x100	7	7	RKL type				
AV075066CV5G2N	750	50	50 + 7x100	15	8	RKL type				
AV080066AV8G2N	800	100	8x100	8	8	RKL type			1608 / 3550	



VarSet Fast

Network voltage 480 & 600 V - 60Hz

Tuning order 4.2



B

Environment

- Installation: Indoor
- Ambient temp: 15 to 104F (-5°C to 40°C)
- Humidity: up to 95%
- Maximum altitude: 6500 feet (2000 m)

Standards

- CSA 22.2 No. 190
- UL810, UL508a

Environment certifications

Produced in 14001 certified plants, product environmental profile available

General characteristics

Electrical Characteristics

Rated Voltage	480V, 600V / 60Hz
Capacitance Tolerance	-5% +10%
Connection type	Three-phase
Power losses	< 13 W per kvar
Maximum permissible over current	1,3 x In
Maximum permissible over voltage	1,1 x Un, 8h per 24h

Enclosure

Degree of protection	NEMA 1
Colour	ASA 49 (AT Model)
Degree of mechanical resistance	Sec 43 UL810

Controller

VarPlus Logic	VarPlus Logic controller with embedded Modbus communication
---------------	---

Head circuit breaker protection

Without incoming circuit breaker	Lug connection LV PFC Bank must be protected by a circuit breaker or by a fused disconnecter on upstream switchboard
With incoming circuit breaker	PowerPact with rotary handle

Step

Capacitors Type	Varplus Can 575V for network voltage 480V VarplusCan 690V for network voltage 600V Maximum overcurrent 1,8xIn 3 ph overpressure disconnection system Discharge resistor: 50V - 1mn
Transient-free switches	Electronically controlled to avoid capacitor switching transients
Detuned Reactor	Varplus DR Overheating protection by thermostat
Circuit breaker protection	PowerPact

Temperature control

Double control	By thermostat and controller
----------------	------------------------------

Communication

ModBUS	RS485
--------	-------

Installation

Customer connection	Top entry
Auxiliary transformer	120V included - no need of additional supply
TI not included	5 VA - secondary 1 A or 5 A To be installed upstream of the load and capacitor bank
GenSet contact	Available for disconnection with the generator
Alarm contact	Available for remote warning signal

Options available on request:

- Fixed stages (by controller programming)
- Custom staging ratios
- Other voltages and frequencies
- Outdoor arrangement - Built to NEMA 3R (AV/BV models only)
- Bottom cable entry to main lugs or main breaker requires incoming cubicle

Network 480V - 60Hz

References	Power (kVAr)	Smallest step	Resolution	No. of electrical and physical steps	Breaking Capacity	Main Circuit breaker	Enclosure type	Enclosure size (H x W x D) mm / in	Max weight (kg/lb)
With incoming circuit breaker									
BT045046AVBF2N	450	150	3x150	6	65 kA	RKL type	BT 1 Section	2324 x 762 x 915 91.5 x 30 x 36 in	900 / 2000
BT060046AVBF2N	600	150	4x150	4		RKL type	BT 2 Sections	2324 x 1524 x 915 91.5 x 60 x 36 in	1400 / 3100
BT090046AVBF3N	900	150	6x150	5		RKL type	BT 2 Sections	2324 x 1524 x 915 91.5 x 60 x 36 in	1540 / 3400
BT120046AVBF3N	1200	150	8x150	6		RKL type	BT 3 Sections	2324 x 2286 x 915 91.5 x 90 x 36 in	2310 / 5100

References	Power (kVAr)	Smallest step	Resolution	No. of electrical and physical steps	Short-time withstand current	Recommended upstream protection	Enclosure type	Enclosure size (H x W x D) mm / in	Max weight (kg/lb)
With main lugs									
AT045046AVBF2N	450	150	3x150	6	65 kA / 4 cycles	RKL type	AT 1 Section	2324 x 762 x 915 91.5 x 30 x 36 in	770 / 1700
AT060046AVBF2N	600	150	4x150	4		RKL type	AT 2 Sections	2324 x 1524 x 915 91.5 x 60 x 36 in	1360 / 3000
AT090046AVBF3N	900	150	6x150	5		RKL type	AT 2 Sections	2324 x 1524 x 915 91.5 x 60 x 36 in	1500 / 3300
AT120046AVBF3N	1200	150	8x150	6		RKL type	AT 3 Sections	2324 x 2286 x 915 91.5 x 90 x 36 in	2270 / 5000

Network 600V - 60Hz

References	Power (kVAr)	Smallest step	Resolution	No. of electrical and physical steps	Breaking Capacity	Main Circuit breaker	Enclosure type	Enclosure size (H x W x D) mm / in	Max weight (kg/lb)
With incoming circuit breaker									
BT045066AVBG2N	450	150	3x150	6	65 kA	RKL type	BT 1 Section	2324 x 1524 x 915 91.5 x 60 x 36 in	900 / 2000
BT060066AVBG2N	600	150	4x150	4		RKL type	BT 2 Sections	2324 x 1524 x 915 91.5 x 60 x 36 in	1400 / 3100
BT090066AVBG3N	900	150	6x150	5		RKL type	BT 2 Sections	2324 x 2286 x 915 91.5 x 90 x 36 in	1540 / 3400
BT120066AVBG3N	1200	150	8x150	6		RKL type	BT 3 Sections	2324 x 2286 x 915 91.5 x 90 x 36 in	2310 / 5100

References	Power (kVAr)	Smallest step	Resolution	No. of electrical and physical steps	Short-time withstand current	Recommended upstream protection	Enclosure type	Enclosure size (H x W x D) mm / in	Max weight (kg/lb)
With main lugs									
AT045066AVBG2N	450	150	3x150	6	65 kA / 4 cycles	RKL type	AT 1 Section	2324 x 1524 x 915 91.5 x 60 x 36 in	770 / 1700
AT060066AVBG2N	600	150	4x150	4		RKL type	AT 2 Sections	2324 x 1524 x 915 91.5 x 60 x 36 in	1360 / 3000
AT090066AVBG3N	900	150	6x150	5		RKL type	AT 2 Sections	2324 x 1524 x 915 91.5 x 60 x 36 in	1500 / 3300
AT120066AVBG3N	1200	150	8x150	6		RKL type	AT 3 Sections	2324 x 2286 x 915 91.5 x 90 x 36 in	2270 / 5000

B

A current transformer is required for automatic control

In order to have automatic control, a current transformer must be ordered in addition to the PFC bank.

A current transformer (not included) is necessary to provide accurate network information to the VarSet's controller in order to apply the correct quantity of kVAR at any given time.

Note: CT must be sized to your network and have a secondary rating of 5 A.

CT catalog number: TRAI****SC^^ where **** is current rate code of bus/cable and ## is window size code. Codes are listed in the table below.

E.g. TRAI1000SC07 is a CT for 1000 A bus with 7" x 4" window.



CT selection table

Current rating of Bus/Cable		Window size	
Amperes	Rating Code ****	7" x 4" size code ##	11" x 4" size code ##
300	0300	07	11
400	0400	07	11
500	0500	07	11
600	0600	07	11
750	0750	07	11
800	0800	07	11
1000	1000	07	11
1200	1200	07	11
1500	1500	07	11
1600	1600	07	11
2000	2000	07	11
2500	2500	07	11
3000	3000	07	11
3500	3500	07	11
4000	4000	07	11
5000	5000	N/A	11
6000	6000	N/A	11

Floor mounting of VLVAW2N and VLVAW3N models

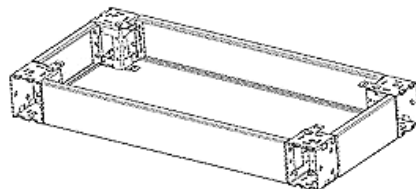

For enclosure	Order the following parts
VLVAW2N	NSYSPF8100 + NSYSPS4100
VLVAW3N	NSYSPF10100 + NSYSPS4100

Construction of references

VarSet Detuned & VarSet Fast

A	V	0300	4	6	A	V	5	F	1	N
Equipment type (2 digits)	Power (4 digits)	Voltage	Series designation	Stage ratio of controller	Cable entry	Smallest step size (kVAR)	Enclosure type and paint	Lug size per phase	N	
AV=automatic standard with main lugs BV= automatic standard with main circuit breaker AT = automatic transient free with main lugs BT = automatic transient free with main circuit breaker	eg. 0300=300kVAR	4 = 480 V 6 = 600 V	6 = Detuned	A= 1:1:1:1:1:1... B= 1:1:2:2:2:2... C= 1:2:2:2:2:2...	V = Top	5=50 8=100 B=150	F=NEMA 1 ASA 49 paint G=NEMA 1 with drip guard ASA 49 paint	Copper saddle clamp 1 = 2 X 1/0 to 500MCM 2 = 4 x 1/0 to 500MCM 3 = 6 x 1/0 to 500MCM	No option	

VarSet Small and Mid-size Standard or Detuned

VLVAW2N	6	6	1	0	0	AA
Equipment type (7 digits)	Voltage	Frequency	Power (3 digits)			Used to differentiate incomer (2 digits)
VLVAW2N: small-size standard VLVAW3N: mid-size standard VLVAF4P: detuned	6 = 480 V 7 = 600 V	6 = 60 Hz	e.g 100 = 100 kVAR			AA = lugs AB = incoming CB



VarSet offer

Typical dimensions

VLVAW2N and VLVAW3N

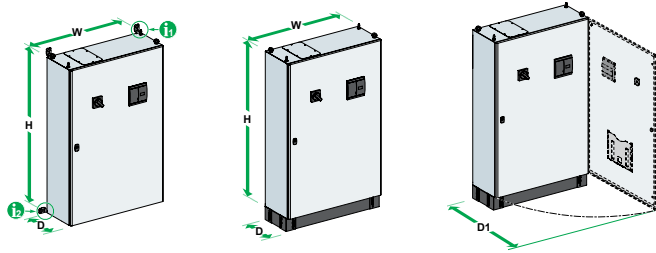

VLVAF4P

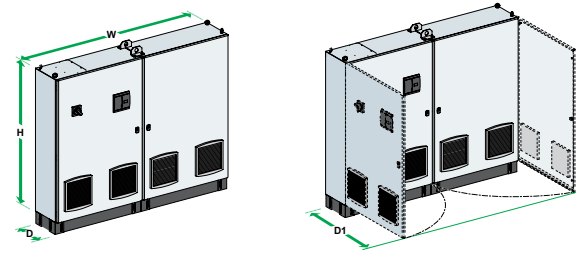

Dimensions and weight

Type	Dimensions (mm / inches)			
	H	W	D	D1
VLVAW2N	850/33.5	800/31.5	400/15.7	1200/47.2
VLVAW3N	1200/47.2	1000/39.4	400/15.7	1400/55.1
VLVAF4P	1200/47.2	1300/51.2	400/15.7	1200/47.2
AV/BV/AT/BT 1 section	2324/91.5*	762/30	915/36	1626/64
AV/BV/AT/BT 2 sections	2324/91.5*	1524/60	915/36	1626/64
AV/BV/AT/BT 3 sections	2324/91.5*	2286/90	915/36	1626/64

* With cable entry 24", H=2934 / 115,5 - Entry cable supplied but to be fitted on field
 * With cable entry 12", H=2629 / 103,5 - Entry cable supplied but to be fitted on field

B

AV,BV,AT,BT models

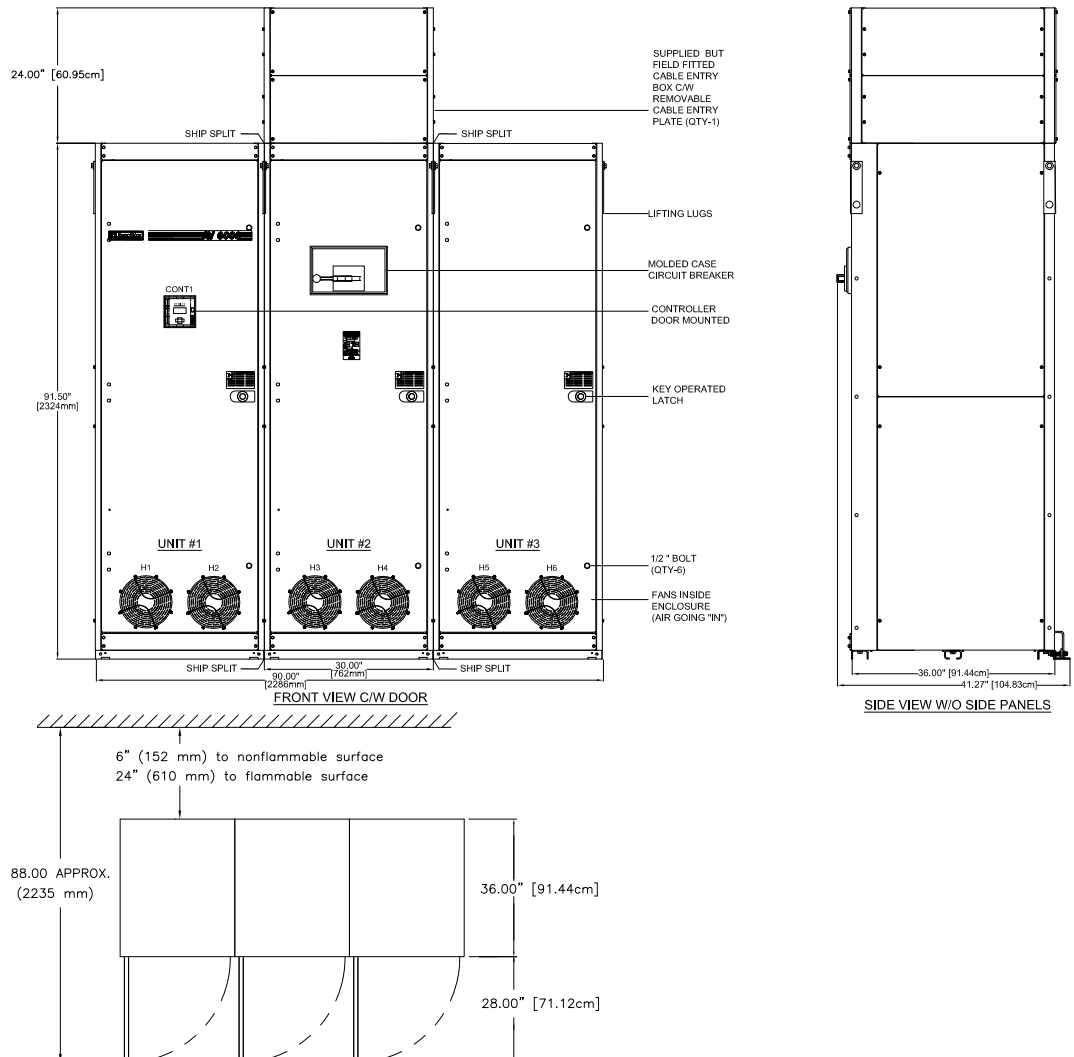

Appendix

Appendix

Power factor of most common receiving devices	39
When should fixed power factor correction be used?	40
Automatic compensation: installation advice	42
General information about harmonics	43
Causes and effects of harmonics	45
VarPlus Logic series.....	47
Calculation of reactive power	50



Other chapters

Power Factor correction Guidelines	10
VarSet offer	20

Power factor of most common receiving devices



Practical calculation of reactive power

Type of circuit	Apparent power S (kVA)	Active power P (kW)	Reactive power Q (kVAr)
Single phase (Ph + N)	$S = V \times I$	$P = V \times I \times \cos \phi$	$Q = V \times I \times \sin \phi$
Single phase (Ph + Ph)	$S = U \times I$	$P = U \times I \times \cos \phi$	$Q = U \times I \times \sin \phi$
Example: 5 kW load $\cos \phi = 0.5$	10 kVA	5 kW	8.7 kVAr
Three-phase (3Ph or 3Ph+N)	$S = \sqrt{3} \times U \times I$	$P = \sqrt{3} \times U \times I \times \cos \phi$	$Q = \sqrt{3} \times U \times I \times \sin \phi$
Example of Motor with $P_n = 51\text{kW}$ $\cos \phi = 0.86$ efficiency = 0.91	65 kVA	56 kW	33 kVAr

Calculations in the three-phase example were as follows:

P_n = power supplied to the rotary axis = 51 kW

P = active consumed power = $P_n/\eta = 56$ kW

S = apparent power = $P/\cos \phi = P/0.86 = 65$ kVA

Hence:

$Q = \sqrt{(S^2 - P^2)} = \sqrt{(65^2 - 56^2)} = 33$ kVAr

The average power factor values for various loads are given below.

Power factor of the most common loads

Device	Load	$\cos \phi$	$\tan \phi$
Ordinary asynchronous motor	0%	0.17	5.8
	25%	0.55	1.52
	50%	0.73	0.94
	75%	0.8	0.75
	100%	0.85	0.62
Incandescent lamps		1	0
Fluorescent lamps		0.5	1.73
Discharge lamps		0.4 to 0.6	2.29 to 1.33
Resistance furnaces		1	0
Induction furnaces		0.85	0.62
Dielectric heating furnaces		0.85	0.62
Resistance welding machine		0.8 to 0.9	0.75 to 0.48
Single-phase static arc-welding centres		0.5	1.73
Rotary arc-welding sets		0.7 to 0.9	1.02
Arc-welding transformers/rectifiers		0.7 to 0.9	1.02 to 0.75
Arc furnaces		0.8	0.75

$\cos \phi$ of the most commonly-used devices.

When should fixed power factor correction be used?

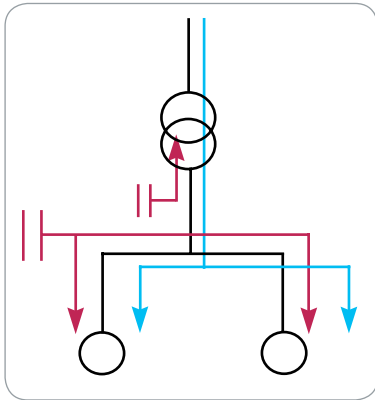

Fig. 7 Power flow in an installation with an uncompensated transformer.

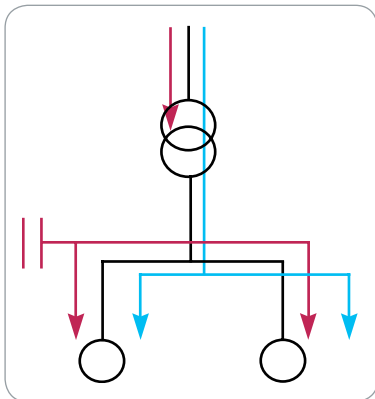

Fig. 8 Power flow in an installation where the transformer is compensated by a fixed power factor correction device.

Fixed power factor correction for transformer

A transformer consumes a reactive power that can be determined approximately by adding:

- a fixed part that depends on the magnetising off-load current I_0 :
 $Q_0 = I_0 \times U_n \times \sqrt{3}$
- a part that is proportional to the square of the apparent power that it conveys:
 $Q = U_{sc} \times S^2 / S_n$

U_{sc} : short-circuit voltage of the transformer in p.u.
 S : apparent power conveyed by the transformer
 S_n : apparent nominal power of the transformer
 U_n : nominal phase-to-phase voltage

The total reactive power consumed by the transformer is: $Q_t = Q_0 + Q$.

If this correction is of the individual type, it can be performed at the actual terminals of the transformer.

If this correction is performed globally with load correction on the busbar of the main switchboard, it can be of the fixed type provided that total power does not exceed 15% of transformer nominal power (otherwise use banks with automatic regulation).

The individual correction values specific to the transformer, depending on transformer nominal power, are listed in the table below.

Transformer S (kVA)	U _{sc} (%)	Oil bath		Dry	
		No-load	Load	No-load	Load
100	4	2.5	5.9	2.5	8.2
160	4	3.7	9.6	3.7	12.9
250	4	5.3	14.7	5.0	19.5
315	4	6.3	18.3	5.7	24
400	4	7.6	22.9	6.0	29.4
500	4	9.5	28.7	7.5	36.8
630	4	11.3	35.7	8.2	45.2
800	4	20.0	66.8	10.4	57.5
1000	6	24.0	82.6	12	71
1250	5.5	27.5	100.8	15	88.8
1600	6	32	126	19.2	113.9
2000	7	38	155.3	22	140.6
2500	7	45	191.5	30	178.2

When should fixed power factor correction be used?

Fixed power factor correction for asynchronous motor

The $\cos \phi$ of motors is normally very poor off-load and when slightly loaded, and poor in normal operating conditions. Installation of capacitors is therefore recommended for this type of load. The table opposite gives, by way of an example, the values for capacitor bank power in kVAR to be installed according to motor power.

Rated power kW	Number of revolutions per minute Reactive power in kVAR				
	HP	3000	1500	1000	750
11	15	2.5	2.5	2.5	5
18	25	5	5	7.5	7.5
30	40	7.5	10	11	12.5
45	60	11	13	14	17
55	75	13	17	18	21
75	100	17	22	25	28
90	125	20	25	27	30
110	150	24	29	33	37
132	180	31	36	38	43
160	218	35	41	44	52
200	274	43	47	53	61
250	340	52	57	63	71
280	380	57	63	70	79
355	485	67	76	86	98
400	544	78	82	97	106
450	610	87	93	107	117

When a motor drives a high inertia load, it may, after breaking of supply voltage, continue to rotate using its kinetic energy and be self-excited by a capacitor bank mounted at its terminals. The capacitors supply the reactive energy required for it to operate in asynchronous generator mode. Such self-excitation results in voltage holding and sometimes in high overvoltages.

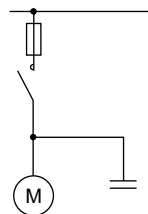

Fig. 9 Mounting capacitors at motor terminals.

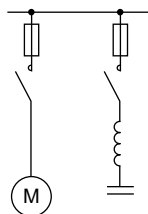

Fig. 10 Parallel-mounting of capacitors with separate operating mechanism.

Correction requirements of asynchronous motors

■ Case of mounting capacitors at the motor terminals

To avoid dangerous overvoltages caused by the self-excitation phenomenon, you must ensure that capacitor bank power verifies the following equation:

$$Q_c \leq 0,9 \times \sqrt{3} \times U_n \times I_0$$

- I_0 : motor off-load current I_0 can be estimated by the following expression:
 $I_0 = 2 \times I_n \times (1 - \cos \phi_n)$
- I_n : value of motor nominal current
- $\cos \phi_n$: $\cos \phi$ of the motor at nominal power
- U_n : nominal phase-to-phase voltage

■ Case of parallel-mounting of capacitors with separate operating mechanism

To avoid dangerous overvoltages due to self-excitation or in cases in which the motor starts by means of special switchgear (resistors, reactors, autotransformers), the capacitors will only be switched after starting.

Likewise, the capacitors must be disconnected before the motor is de-energised. In this case, motor reactive power can be fully corrected on full load.

Caution: if several banks of this type are connected in the same network, inrush current limiting reactors should be fitted.



Automatic compensation: installation advice

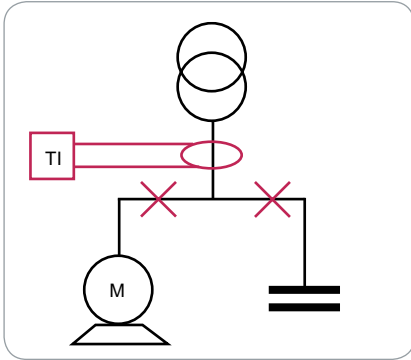

Fig. 11 Diagram of connection to a single LV busbar and CT location.

Single busbar compensation

General

An installation with a single LV busbar is that most often encountered. This type of installation requires that the reactive power can change with respect to the methods defined previously.

Compensation uses all the receiving devices of the installation and the amperage of the current transformer is determined according to the total current conducted through the main protection circuit breaker.

Precautions during installation

As mentioned previously, it will be necessary to ensure a complementary installation of the current transformer so that it can read the total consumption of the installation. It is indispensable to set up the current transformer (CT) in accordance with **Fig. 11**, and installing the system at any of the points indicated by a cross would result in the system malfunctioning.

Compensation with several busbars

Independent LV busbars

Another installation possibility is to have the various independent busbars which do not require to be connected to two identical transformers. For this reason: the reactive power requirement will be different for each busbar and need to be evaluated separately using the methods defined previously.

Compensation will use all the receiving devices and the amperage of each current transformer will be determined according to the total current through the main protection circuit breaker of each busbar.

Installation precautions

In a similar manner to the previous case, the location of each current transformer (CT) will need to be decided upon in the same way so that some transformers can read the consumption in each part of the installation separately.

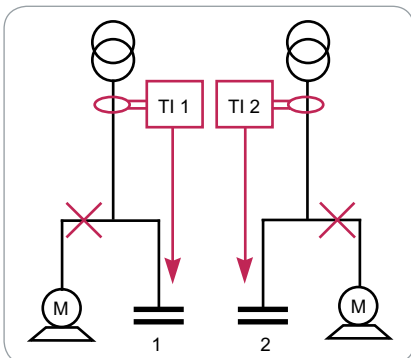

Fig. 12 Diagram of connection to independent LV busbars and CT location.

Compensation for a busbar supplied by various transformers

An installation differing from the above is one in which there are many transformers connected in parallel on the low voltage side.

Separate distribution transformers

Compensation in this installation can be obtained by placing together the two automatic batteries and their respective current transformers.

Equal distribution transformers

In this case, it will be possible to obtain compensation with a single bank in which the controller is powered by a summing transformer, itself powered by the two CTs of each transformer.

The maximum number of summing inputs is 5 (**Fig. 13**).

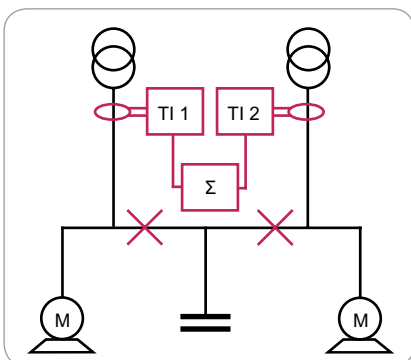

Fig. 13 Diagram of various transformers connected in parallel and TI location.

Installation precautions

■ Separate distribution transformers:

Each bank is powered by a separate CT connected to the output of each transformer. The settings and the installation must be made as if these were independent busbars.

■ Equal distribution transformers:

Compensation uses a single bank and the only precaution is to be made on start up: the C/K relation that needs to be programmed into the controller must consider the sum of all the CTs feeding the summing circuit.

General information about harmonics

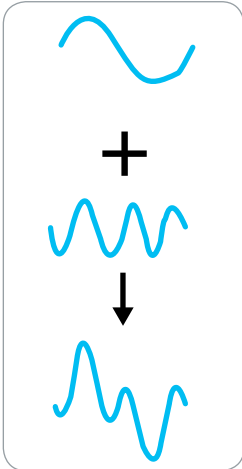

Fig. 14 Decomposition of a distorted wave.

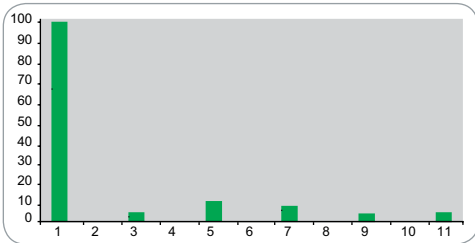

Fig. 15 Typical graph of the frequency spectrum
The frequency spectrum, also known as the spectral analysis, indicates the types of harmonic generator present on the network.

Introduction

Harmonics are usually defined by two main characteristics:

- Their amplitude:
value of the harmonic voltage or current.
- Their order:
value of their frequency with respect to the fundamental frequency (50 Hz).

Under such conditions, the frequency of a 5th order harmonic is five times greater than the fundamental frequency, i.e. 5 x 50 Hz = 250 Hz.

The root mean square value

The rms value of a distorted wave is obtained by calculating the quadratic sum of the different values of the wave for all the harmonic orders that exist for this wave:

Rms value of I:

$$I(A) = \sqrt{I_1^2 + I_2^2 + \dots + I_n^2}$$

The rms value of all the harmonic components is deduced from this calculation:

$$I_n(A) = \sqrt{I_2^2 + \dots + I_n^2}$$

This calculation shows one of the main effects of harmonics, i.e. the increased rms current passing through an installation, due to the harmonic components with which a distorted wave is associated.

Usually, the switchgear and cables or the busbar trunking of the installation is defined from the rated current at the fundamental frequency; all these installation components are not designed to withstand excessive harmonic current.



General information about harmonics

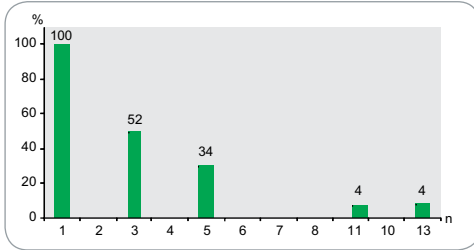

Fig. 16 Harmonic spectrum for single phase industrial devices, induction furnaces, welding machines, rectifiers, etc.

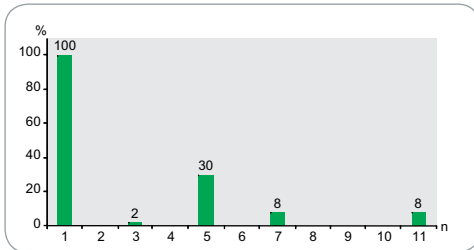

Fig. 17 Harmonic spectrum for 3 phases variable speed drives, asynchronous motors or direct current motors.

Harmonic measurement: distortion

The presence of varying amounts of harmonics on a network is called distortion. It is measured by the harmonic distortion rates:

■ Th: individual distortion rate

It indicates, as a %, the magnitude of each harmonic with respect to the value of the fundamental frequency:

$$Th (\%) = Ah / A1$$

Where:

Ah = the value of the voltage or current of the h-order harmonic.

A1 = the value of the voltage or current at the fundamental frequency (50 Hz).

■ THD: Total Harmonic Distortion

It indicates, as a %, the magnitude of the total distortion with respect to the fundamental frequency or with respect to the total value of the wave.

$$THD_{CIGREE} = \frac{\sqrt{\sum_z^h A_n^2}}{A_1} \quad THD_{IEC 555} = \frac{\sqrt{\sum_z^h A_n^2}}{\sum_1^h A_n^2}$$

The operating values used to find the true situation of the installations with respect to the degree of harmonic contamination are:

- **The total harmonic voltage distortion [THD(U)]** indicating the voltage wave distortion and the ratio of the sum of the harmonic voltages to the fundamental frequency voltage, all expressed as a %.
- **The total harmonic current distortion [THD(I)]** determining the current wave distortion and the ratio of the sum of the harmonic currents to the fundamental frequency current, expressed as a %.
- **The frequency spectrum (TFT)** is a diagram that gives the magnitude of each harmonic according to its order.
By studying it, we can determine which harmonics are present and their respective magnitude.

Interharmonics

Interharmonics are sinusoidal components with frequencies that are not integral multiples of the fundamental frequency (and therefore situated between the harmonics). They are the result of periodic or random variations of the power absorbed by different loads such as arc furnaces, welding machines and frequency converters (variable speed drives, cycloconvertors).

Causes and effects of harmonics

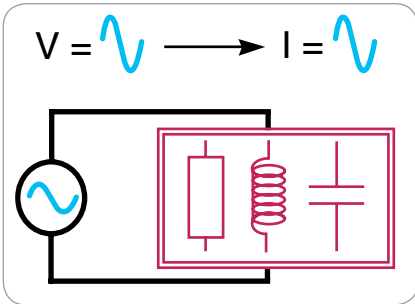

Fig. 18 Linear loads such as inductors, capacitors and resistors do not generate harmonics.

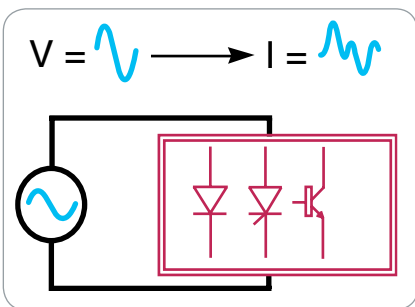

Fig. 19 Non-linear loads are those that generate harmonics.



Harmonic generators

Harmonics are generally produced by non-linear loads which, although powered by a sinusoidal voltage, absorb a non-sinusoidal current.

In short, non-linear loads are considered to behave as current sources that inject harmonics into the network.

The most common non-linear harmonic loads are those found in devices fed by power electronics, such as variable speed drives, rectifiers, converters, etc.

Loads such as saturable reactors, welding equipment, arc furnaces etc. also inject harmonics.

Other loads have a linear behaviour and do not generate harmonics: inductors, resistors and capacitors.

Main harmonic sources

We differentiate between these loads, according to whether they are used for industrial or residential applications:

- Industrial loads:
 - power electronics devices: variable speed drives, rectifiers, UPS, etc.
 - loads using an electric arc: arc furnaces, welding machines, lighting (fluorescent lamps, etc.); harmonics (temporary) are also generated when motors are started with an electronic starter and when power transformers come into service.
- Residential loads: TVs, microwave ovens, induction plates, computers, printers, fluorescent lamps, etc.

The following table is a guide to the various loads with information on the injected harmonic current spectrum.

Indications about the harmonic spectrum injected by various loads

Type of load	Harmonics generated	Comments
Transformer	Even and odd order	DC component
Asynchronous motors	Odd order	Interharmonics and subharmonics
Discharge lamp	3. ^o + odd	Can reach 30% of I1
Arc welding	3. ^o	
AC arc furnaces	Unstable variable spectrum	Non linear - asymmetric
Inductive filter rectifier	$h = K \times P \pm 1$ $I_h = I1/h$	UPS - variable speed drives V
Capacitive filter rectifier	$h = K \times P \pm 1$ $I_h = I1/h$	Electronic device power supply
Cycloconverter	Variables	Variable speed drives V
PWM controllers	Variables	UPS - DC - AC converter



Causes and effects of harmonics



Fig. 20 Cables.



Fig. 21 Induction furnace.



Fig. 22 VarplusCan capacitor.

The effects of harmonics on loads

The following two types of effects appear in the main equipment: immediate or short-term effects and long-term effects.

Immediate or short-term effects:

- Unwanted tripping of protection devices,
- Induced interference from LV current systems (remote control, telecommunications),
- Abnormal vibrations and noise,
- Damage due to capacitor thermal overload,
- Faulty operation of non-linear loads.

Long-term effects associated with current overload that causes overheating and premature deterioration of the equipment.

Affected devices and effects:

- Power capacitors:
 - additional losses and overheating,
 - fewer possibilities of use at full load,
 - vibrations and mechanical wear,
 - acoustic disComfort.
- Motors:
 - additional losses and overheating,
 - fewer possibilities of use at full load,
 - vibrations and mechanical wear,
 - acoustic disComfort.
- Transformers:
 - additional losses and overheating,
 - mechanical vibrations,
 - acoustic disComfort.
- automatic switch:
 - unwanted tripping due to the peak current being exceeded.
- Cables:
 - additional dielectric and chemical losses, especially on the neutral, when 3rd order harmonics are present,
 - overheating.
- Computers:
 - functional disruptions causing data losses or faulty operation of control equipment.
- Power electronics:
 - waveform interference: switching, synchronisation, etc.

Summary table of effects, causes and consequences of harmonics

Effects of the harmonics	Causes	Consequences
On the conductors	<ul style="list-style-type: none"> ■ The harmonic currents cause the I_{rms} to increase ■ The skin effect reduces the effective crosssection of the conductors as the frequency increases 	<ul style="list-style-type: none"> ■ Unwanted tripping of the protection devices ■ Overheated conductors
On the neutral conductor	<ul style="list-style-type: none"> ■ A balanced three-phase + neutral load generates 3rd order multiple odd harmonics 	<ul style="list-style-type: none"> ■ Closure of homopolar harmonics on the neutral, causing overheating and overcurrents
On the transformers	<ul style="list-style-type: none"> ■ Increased IRMS ■ Foucault losses are proportional to the frequency 	<ul style="list-style-type: none"> ■ Increased overheating due to the Joule effect in the windings ■ Increased losses in iron
On the motors	<ul style="list-style-type: none"> ■ Similar to those for the transformers and generation of a field added to the main one 	<ul style="list-style-type: none"> ■ Similar to those of transformers, plus efficiency losses
On capacitors	<ul style="list-style-type: none"> ■ Decreased capacitor impedance with increased frequency 	<ul style="list-style-type: none"> ■ Premature ageing, amplification of the existing harmonics

VarPlus Logic has all what you need for the simple and efficient operation of your automatic power factor correction equipment to maintain your power factor.

It is a simple and intelligent relay which measure, monitor and controls the reactive energy. Easy commissioning, step size detection and monitoring makes it different from others in the market.



VarPlus Logic VL6, VL12

Capacitor bank step monitoring

- Monitoring of all the connected capacitor steps.
- Real time power in "kvar" for the connected steps .
- Remaining step capacity per step as a % of the original power since installation.
- Derating since installation.
- Number of switching operations of every connected step.

System Measurement and monitoring

- THD(u) and THD(u) Spectrum 3rd to 19th – Measurement, Display and Alarm.
- Measurement of DQ – "kvar" required to achieve target cos phi.
- Present cabinet temperature and maximum recorded temperature.
- System parameters – Voltage, Current, Active, reactive and apparent power.
- Large LCD display to monitor real step status and other parameters.

Easy Commissioning

- Automatic Initialization and automatic step detection to do a auto commissioning.
- Automatic wiring correction - voltage and current input wiring correction.
- 1 A or 5 A CT secondary compatible.

Flexibility to the panel builder and retrofitting

- No step sequence restriction like in the traditional relays.
- Any step sequences with auto detect. No programming needed.
- Easy to retrofit the faulty capacitor with different power.
- Quick and simple mounting and wiring.
- Connect to the digitized Schindler solutions through RS485 communication in Modbus protocol.
- Seamless connection to the Schneider software and gateways.

Do more with VarPLUS Logic

- Programmable alarms with last 5 alarms log.
- Suitable for medium voltage applications.
- Suitable for 4 quadrant operations.
- Dual cos phi control through digital inputs or export power detection.
- Dedicated alarm and fan control relays.
- Advance expert programming Menu to configure the controller the way you need.
- New control algorithm designed to reduce the number of switching operations and quickly attain the targeted power fact.

Alarms

- Faulty Step.
- Configurable alarm for step derating.
- THDu Limit alarm.
- Temperature alarm.
- Self correction by switching off the steps at the event of THDu alarm, temperature alarm and overload limit alarm.
- Under compensation alarm.
- Under/Over Voltage Alarm.
- Low/High Current Alarm.
- Overload limit alarm.
- Hunting alarm.
- Maximum operational limits - Time and number of switching.

Range

Type	Number of step output contacts	Part number
VL6	06	VPL06N
VL12	12	VPL12N



General characteristics

Voltage and current Input

Direct supply voltage	90 – 550 V, 1ph, 50/60 Hz VA Burden: 6 VA 300 V LN / 519 V LL CAT III or 550 V CAT II
Type of input connection	Phase to phase or phase to neutral
Protection against voltage dips	Automatic disconnection of steps for dips > 15 ms (protection of capacitor)
CT secondary	1A or 5A compatible
CT primary range	Up to 9600 A
Current	15 mA – 6 A, 1PH, VA Burden : < 1 VA
Connection terminals	Screw type, pluggable. Section: 0.2 – 2.5 mm ² (0.2 – 1 mm ² for Modbus and digital inputs)

Power factor settings & algorithm selection

Regulation setting - Programmable	From Cos Phi 0.7c to 0.7i
Reconnection time -Programmable	From 1 to 6500 s
Response time -Programmable	From 1 to 6500 s
Possibility of dual cos Phi target	Yes, Through Digital Input or if export power detected
Program algorithm	AUTOMATIC (best fit) - Default LIFO PROGRESSIVE
Import export application compatibility	4- Quadrant operation for generator application

Program intelligence

Automatic Initialization and Automatic bank detection	Yes
Detection and display of power, number of switching & derating of all connected steps	Yes
Capacitor bank step sequence	Any sequence. No restriction/limitation on sequence

Dimensions

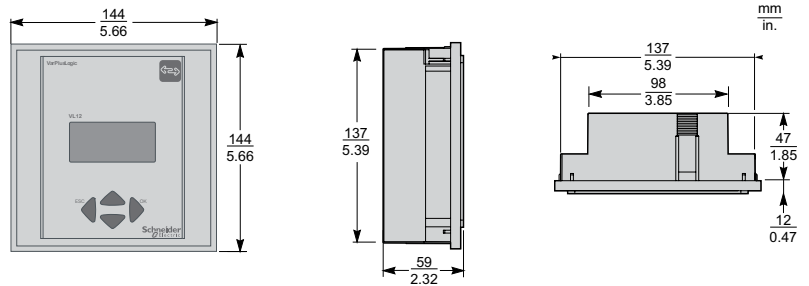

Mounting

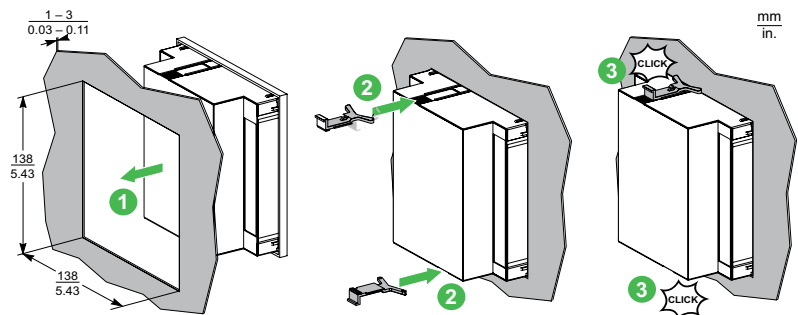

Phase-to-Neutral with VTs (3PH4W)

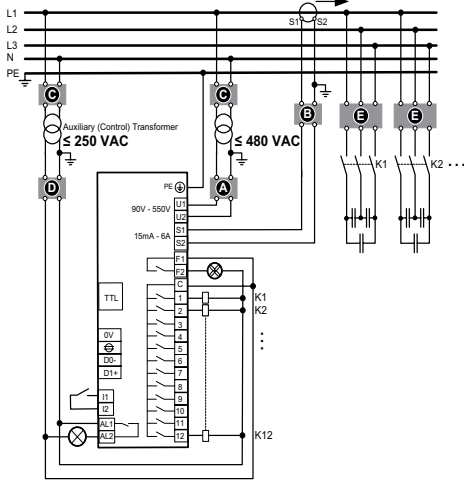

Phase-to-Phase with VTs (3PH3W)

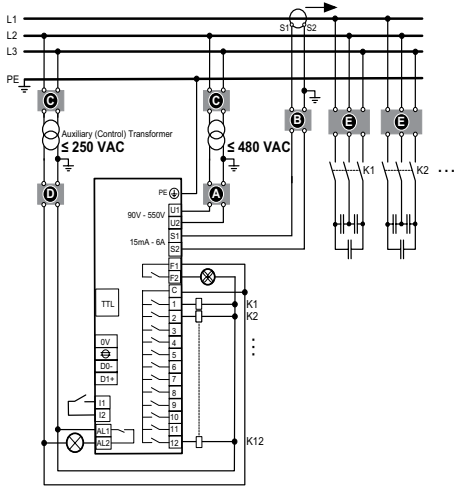

- A** Upstream protection
Voltage input: 2A certified circuit breakers or fuses
- B** Shorting block for CT
- C** VT primary fuses and disconnect switch
- D** Output relays: 10 A (max.) certified circuit breakers or fuses
(Applicable for applications with voltage transformers only)
- E** Capacitor primary fuses or CB's

General characteristics

Alarm and control

Control outputs (step output)	VL6: 6 relays VL12: 12 relays (NO contact) 250 V LN or LL (CAT III) DC Rating : 48 V DC / 1 A AC Rating : 250 V AC / 5 A Common root: 10 A max.
Dedicated fan control relay	Yes. Normal open contact (NO) 48 V DC / 1 A, 250 V AC / 5 A
Alarm contact	The relay contact is open when the controller is energized with no alarm and will close in the event of an alarm. The relay is a NC (Normally Close) when the controller is not energized. Rating : 48 V DC / 1 A, 250 V AC / 5 A
Digital Input for Cos phi2 target	Dry contact (internal supply 5 V, 10 mA)
Modbus RS-485 serial port (RTU)	Line polarization / termination, not included
Communication protocol	Modbus
Interface TTL	Service port. Only for internal use
Internal Temperature probe	Yes

Display and measurement

Display	LCD graphic 56 x 25 (Backlit)
Alarms log	5 last alarms
Voltage Harmonic Distortion measurement	THDu ; Individual odd harmonics distortion from H3 to H19
Measurement displayed and accuracy	Voltage, Current & Frequency: $\pm 1\%$ Energy measurements, Cos Phi, THD(u): $\pm 2\%$ Individual Voltage harmonics (H3 to H19): $\pm 3\%$ Temperature measurement : $\pm 3^\circ\text{C}$

Testing standards and conformities

Standards	IEC 61010-1 IEC 61000 6-2 IEC 61000 6-4: level B IEC 61326-1 UL 61010
Conformity and listing	Conformity and listing CE, NRTL, c NRTL, EAC

Mechanical specifications

Case	Front: Instrument case plastic RAL 7016 Rear: Metal
Degree of Protection	Front: IP41, (IP54 by using a gasket) Rear: IP20
Weight	0.6 kg
Size	144 x 144 x 58 mm (H x W x D)
Panel Cutout	138 x 138 (+0.5) mm, thickness 1 – 3 mm
Panel Mounting	Flush mounting

Storage condition

Temperature for operation	-20 °C +60 °C
Storage	-40 °C +85 °C
Humidity	0% - 95%, without condensation for operation and storage
Maximum pollution degree	2
Maximum altitude	$\leq 2000\text{m}$



Calculation of reactive power Selection Table

Calculation of reactive power: Selection table

The table gives a coefficient, according to the $\cos \varphi$ of the installation before and after power factor correction. Multiplying this figure by the active power gives the reactive power to be installed.

Before compensation		Capacitor power in kVar to be installed per kW of load to raise the power factor ($\cos \varphi$ or $\text{tg } \varphi$)													
$\text{tg } \varphi$	$\cos \varphi$	$\text{tg } \varphi$	0.75	0.59	0.48	0.45	0.42	0.39	0.36	0.32	0.29	0.25	0.20	0.14	0.00
		$\cos \varphi$	0.8	0.86	0.9	0.91	0.92	0.93	0.94	0.95	0.96	0.97	0.98	0.99	1
2.29	0.40		1.541	1.698	1.807	1.836	1.865	1.896	1.928	1.963	2.000	2.041	2.088	2.149	2.291
2.22	0.40		1.475	1.631	1.740	1.769	1.799	1.829	1.862	1.896	1.933	1.974	2.022	2.082	2.225
2.16	0.42		1.411	1.567	1.676	1.705	1.735	1.766	1.798	1.832	1.869	1.910	1.958	2.018	2.161
2.10	0.43		1.350	1.506	1.615	1.644	1.674	1.704	1.737	1.771	1.808	1.849	1.897	1.957	2.100
2.04	0.44		1.291	1.448	1.557	1.585	1.615	1.646	1.678	1.712	1.749	1.790	1.838	1.898	2.041
1.98	0.45		1.235	1.391	1.500	1.529	1.559	1.589	1.622	1.656	1.693	1.734	1.781	1.842	1.985
1.93	0.46		1.180	1.337	1.446	1.475	1.504	1.535	1.567	1.602	1.639	1.680	1.727	1.788	1.930
1.88	0.47		1.128	1.285	1.394	1.422	1.452	1.483	1.515	1.549	1.586	1.627	1.675	1.736	1.878
1.83	0.48		1.078	1.234	1.343	1.372	1.402	1.432	1.465	1.499	1.536	1.577	1.625	1.685	1.828
1.78	0.49		1.029	1.186	1.295	1.323	1.353	1.384	1.416	1.450	1.487	1.528	1.576	1.637	1.779
1.73	0.5		0.982	1.139	1.248	1.276	1.306	1.337	1.369	1.403	1.440	1.481	1.529	1.590	1.732
1.69	0.51		0.937	1.093	1.202	1.231	1.261	1.291	1.324	1.358	1.395	1.436	1.484	1.544	1.687
1.64	0.52		0.893	1.049	1.158	1.187	1.217	1.247	1.280	1.314	1.351	1.392	1.440	1.500	1.643
1.60	0.53		0.850	1.007	1.116	1.144	1.174	1.205	1.237	1.271	1.308	1.349	1.397	1.458	1.600
1.56	0.54		0.809	0.965	1.074	1.103	1.133	1.163	1.196	1.230	1.267	1.308	1.356	1.416	1.559
1.52	0.55		0.768	0.925	1.034	1.063	1.092	1.123	1.156	1.190	1.227	1.268	1.315	1.376	1.518
1.48	0.56		0.729	0.886	0.995	1.024	1.053	1.084	1.116	1.151	1.188	1.229	1.276	1.337	1.479
1.44	0.57		0.691	0.848	0.957	0.986	1.015	1.046	1.079	1.113	1.150	1.191	1.238	1.299	1.441
1.40	0.58		0.655	0.811	0.920	0.949	0.969	1.009	1.042	1.076	1.113	1.154	1.201	1.262	1.405
1.37	0.59		0.618	0.775	0.884	0.913	0.942	0.973	1.006	1.040	1.077	1.118	1.165	1.226	1.368
1.33	0.6		0.583	0.740	0.849	0.878	0.907	0.938	0.970	1.005	1.042	1.083	1.130	1.191	1.333
1.30	0.61		0.549	0.706	0.815	0.843	0.873	0.904	0.936	0.970	1.007	1.048	1.096	1.157	1.299
1.27	0.62		0.515	0.672	0.781	0.810	0.839	0.870	0.903	0.937	0.974	1.015	1.062	1.123	1.265
1.23	0.63		0.483	0.639	0.748	0.777	0.807	0.837	0.873	0.904	0.941	0.982	1.030	1.090	1.233
1.20	0.64		0.451	0.607	0.716	0.745	0.775	0.805	0.838	0.872	0.909	0.950	0.998	1.058	1.201
1.17	0.65		0.419	0.672	0.685	0.714	0.743	0.774	0.806	0.840	0.877	0.919	0.966	1.027	1.169
1.14	0.66		0.388	0.639	0.654	0.683	0.712	0.743	0.775	0.810	0.847	0.888	0.935	0.996	1.138
1.11	0.67		0.358	0.607	0.624	0.652	0.682	0.713	0.745	0.779	0.816	0.857	0.905	0.966	1.108
1.08	0.68		0.328	0.576	0.594	0.623	0.652	0.683	0.715	0.750	0.788	0.828	0.875	0.936	1.078
1.05	0.69		0.299	0.545	0.565	0.593	0.623	0.654	0.686	0.720	0.757	0.798	0.846	0.907	1.049
1.02	0.7		0.270	0.515	0.536	0.565	0.594	0.625	0.657	0.692	0.729	0.770	0.817	0.878	1.020
0.99	0.71		0.242	0.485	0.508	0.536	0.566	0.597	0.629	0.663	0.700	0.741	0.789	0.849	0.992
0.96	0.72		0.214	0.456	0.480	0.508	0.538	0.569	0.601	0.635	0.672	0.713	0.761	0.821	0.964
0.94	0.73		0.186	0.427	0.452	0.481	0.510	0.541	0.573	0.608	0.645	0.686	0.733	0.794	0.936
0.91	0.74		0.159	0.398	0.425	0.453	0.483	0.514	0.546	0.580	0.617	0.658	0.706	0.766	0.909
0.88	0.75		0.132	0.370	0.398	0.426	0.456	0.487	0.519	0.553	0.590	0.631	0.679	0.739	0.882
0.86	0.76		0.105	0.343	0.371	0.400	0.429	0.460	0.492	0.526	0.563	0.605	0.652	0.713	0.855
0.83	0.77		0.079	0.316	0.344	0.373	0.403	0.433	0.466	0.500	0.537	0.578	0.626	0.686	0.829
0.80	0.78		0.052	0.289	0.318	0.347	0.376	0.407	0.439	0.474	0.511	0.552	0.599	0.660	0.802
0.78	0.79		0.026	0.262	0.292	0.320	0.350	0.381	0.413	0.447	0.484	0.525	0.573	0.634	0.776
0.75	0.8			0.235	0.266	0.294	0.324	0.355	0.387	0.421	0.458	0.499	0.547	0.608	0.750
0.72	0.81			0.209	0.240	0.268	0.298	0.329	0.361	0.395	0.432	0.473	0.521	0.581	0.724
0.70	0.82			0.183	0.214	0.242	0.272	0.303	0.335	0.369	0.406	0.447	0.495	0.556	0.698
0.67	0.83			0.157	0.188	0.216	0.246	0.277	0.309	0.343	0.380	0.421	0.469	0.530	0.672
0.65	0.84			0.131	0.162	0.190	0.220	0.251	0.283	0.317	0.354	0.395	0.443	0.503	0.646
0.62	0.85			0.105	0.135	0.164	0.194	0.225	0.257	0.291	0.328	0.369	0.417	0.477	0.620
0.59	0.86			0.079	0.109	0.138	0.167	0.198	0.230	0.265	0.302	0.343	0.390	0.451	0.593
0.56	0.87			0.053	0.082	0.111	0.141	0.172	0.204	0.238	0.275	0.316	0.364	0.424	0.567
0.53	0.88			0.029	0.055	0.084	0.114	0.145	0.177	0.211	0.248	0.289	0.337	0.397	0.540
0.51	0.89				0.028	0.057	0.086	0.117	0.149	0.184	0.221	0.262	0.309	0.370	0.512
0.48	0.90					0.029	0.058	0.089	0.121	0.156	0.193	0.234	0.281	0.48	0.484

Find more about Power Quality Solutions

We deliver smart & cost-effective Power quality solutions to improve our customers' efficiency.

Reactive Energy Management

Low Voltage components



Find out more visit www.schneider-electric.com and download [PFCED310003EN](#)

AccuSine

Harmonic Filtering and Reactive Power Compensations

The Schneider Electric solution for active harmonic filtering in industrial and building installations



Find out more visit www.schneider-electric.com and download [AMTED109015EN](#)

Relevant documents

Relevant documents published by Schneider Electric

- Electrical Installation Guide.
- Expert Guide n°4: "Harmonic detection & filtering".
- Expert Guide n°6: "Power Factor Correction and Harmonic Filtering Guide"
- Technical Guide 152: "Harmonic disturbances in networks, and their treatment".
- White paper: controlling the impact of Power Factor and Harmonics on Energy Efficiency.

Relevant websites

- <http://www.schneider-electric.com>
- <https://www.schneider-electric.com/en/product-range/61501-varset-lv>
- <http://engineering.electrical-equipment.org/>
- <http://www.electrical-installation.org>

Relevant standards

- CSA 22.2 No.190 - Capacitors for power factor correction
- UL810 - Capacitors
- UL508a - Standard for industrial panels

Index of references

Reference	Page(s)	Reference	Page(s)	Reference	Page(s)
VLVAW2N					
VLVAW2N66075AB	27	VLVAF4P66100AA	29	AV030046BV5F1N	29
VLVAW2N66100AB	27	VLVAF4P66125AA	29	AV035046CV5F1N	29
VLVAW2N66075AA	27	VLVAF4P66150AA	29	AV040046AV8F1N	29
VLVAW2N66100AA	27	VLVAF4P66175AA	29	AV020066BV5G1N	31
VLVAW2N76050AB	27	VLVAF4P66200AA	29	AV025066CV5G1N	31
VLVAW2N76075AB	27	VLVAF4P76075AB	31	AV030066BV5G1N	31
VLVAW2N76100AB	27	VLVAF4P76100AB	31	AV035066CV5G1N	31
VLVAW2N76050AA	27	VLVAF4P76125AB	31	AV040066AV8G1N	31
VLVAW2N76075AA	27	VLVAF4P76150AB	31	AV 2 Sections	
VLVAW2N76100AA	27	VLVAF4P76175AB	31	AV045046CV5F2N	29
VLVAW3N					
VLVAW2N66075AB	27	VLVAF4P76200AB	31	AV050046AV8F2N	29
VLVAW2N66100AB	27	VLVAF4P76075AA	31	AV055046CV5F2N	29
VLVAW2N66075AA	27	VLVAF4P76100AA	31	AV060046AV8F2N	29
VLVAW2N66100AA	27	VLVAF4P76125AA	31	AV065046CV5F2N	29
VLVAW2N76050AB	27	VLVAF4P76150AA	31	AV070046AV8F2N	29
VLVAW2N76075AB	27	VLVAF4P76175AA	31	AV075046CV5F2N	29
VLVAW2N76100AB	27	VLVAF4P76200AA	31	AV080046AV8F2N	29
VLVAW2N76050AA	27	BV 1 Section		AV045066CV5G2N	31
VLVAW2N76075AA	27	BV025046CV5F1N	29	AV050066AV8G2N	31
VLVAW2N76100AB	27	BV030046BV5F1N	29	AV055066CV5G2N	31
VLVAW2N76050AA	27	BV020066BV5G1N	31	AV060066AV8G2N	31
VLVAW2N76075AA	27	BV025066CV5G1N	31	AV065066CV5G2N	31
VLVAW2N76100AA	27	BV030066BV5G1N	31	AV070066AV8G2N	31
VLVAW3N66125AA	27	BV 2 Sections		AV075066CV5G2N	31
VLVAW3N66150AA	27	BV035046CV5F2N	29	AV080066AV8G2N	31
VLVAW3N66175AA	27	BV040046AV8F2N	29	BT 1 Section	
VLVAW3N66200AA	27	BV045046CV5F2N	29	BT045046AVBF2N	33
VLVAW3N66225AA	27	BV050046AV8F2N	29	BT045066AVBG2N	33
VLVAW3N66250AA	27	BV055046CV5F2N	29	BT 2 Sections	
VLVAW3N76125AB	27	BV060046AV8F2N	29	BT060046AVBF2N	33
VLVAW3N76150AB	27	BV065046CV5F2N	29	BT090046AVBF3N	33
VLVAW3N76175AB	27	BV070046AV8F2N	29	BT060066AVBG2N	33
VLVAW3N76175AB	27	BV035066CV5G2N	31	BT090066AVBG3N	33
VLVAW3N76200AB	27	BV040066AV8G2N	31	BT 3 Sections	
VLVAW3N76225AB	27	BV045066CV5G2N	31	BT120046AVBF3N	33
VLVAW3N76250AB	27	BV050066AV8G2N	31	BT120066AVBG3N	33
VLVAW3N76125AA	27	BV055066CV5G2N	31	AT 1 Section	
VLVAW3N76150AA	27	BV060066AV8G2N	31	AT045046AVBF2N	33
VLVAW3N76175AA	27	BV065066CV5G2N	31	AT045066AVBG2N	33
VLVAW3N76200AA	27	BV070066AV8G2N	31	AT 2 Sections	
VLVAW3N76225AA	27	BV 3 Sections		AT060046AVBF2N	33
VLVAW3N76250AA	27	BV075046CV5F3N	29	AT090046AVBF3N	33
VLVAF4P					
VLVAF4P66075AB	29	BV080046AV8F3N	29	AT060066AVBG2N	33
VLVAF4P66100AB	29	BV075066CV5G3N	31	AT090066AVBG3N	33
VLVAF4P66125AB	29	BV080066AV8G3N	31	AT 3 Sections	
VLVAF4P66150AB	29	AV 1 Section		AT120046AVBF3N	33
VLVAF4P66175AB	29	AV025046CV5F1N	29	AT120066AVBG3N	33
VLVAF4P66200AB	29				
VLVAF4P66075AA	29				

Notes



Schneider Electric Industries SAS

35, rue Joseph Monier
CS 30323
92506 Rueil Malmaison Cedex
France

RCS Nanterre 954 503 439
Capital social 896 313 776 €
www.schneider-electric.com

08-2018
PFCED310004NAM

© 2018 - Schneider Electric - All rights reserved.
Toutes les marques déposées sont la propriété de Schneider Electric Industries SAS ou de ses filiales.