

Alle Rechte vorbehalten.
Tous droits réservés.
All rights reserved.
© Schneider Electric Austria Ges.m.b.H.

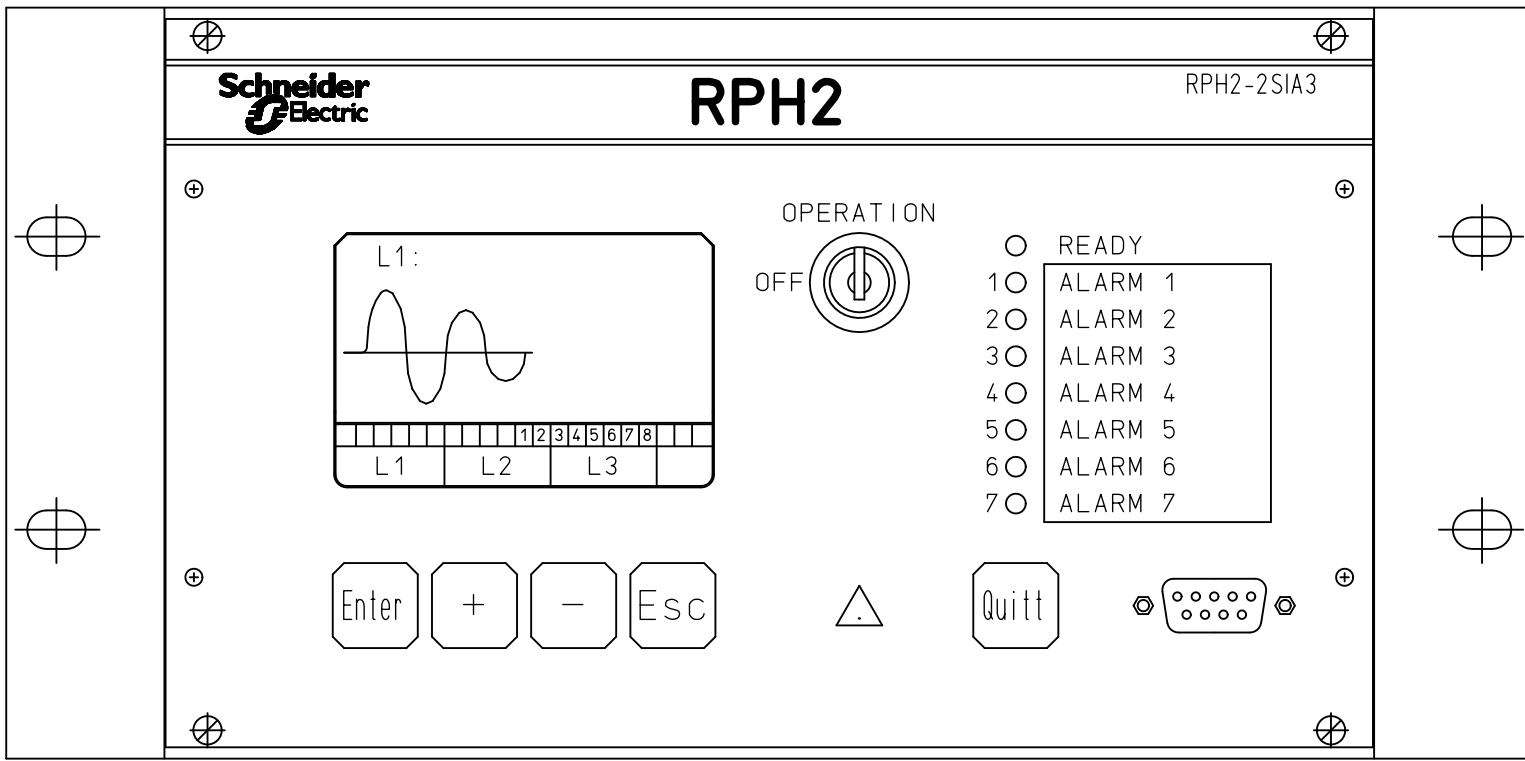

PROJEKT:
RPH2

09	-	31.05.16	Gu	DATE	1.10.96	POINT-ON-WAVE CONTROLLER RPH2 WIRING DIAGRAM	Schneider Electric	Cover sheet	Model: RPH2-2SIA3		01	
				DRAWN	THS/Höflinger							
				CHECK	THS/Samitz							
STATE	ALTERATION	DATE	NAME	STAND.		ORIG.	REPL.F.	REPL.T.		B _{A3}	58.010.111-26E	PAGE 01 16 PAGES

Alle Rechte vorbehalten.
Tous droits réservés.
All rights reserved.
© Schneider Electric Austria Ges.m.b.H.

front view

rear view

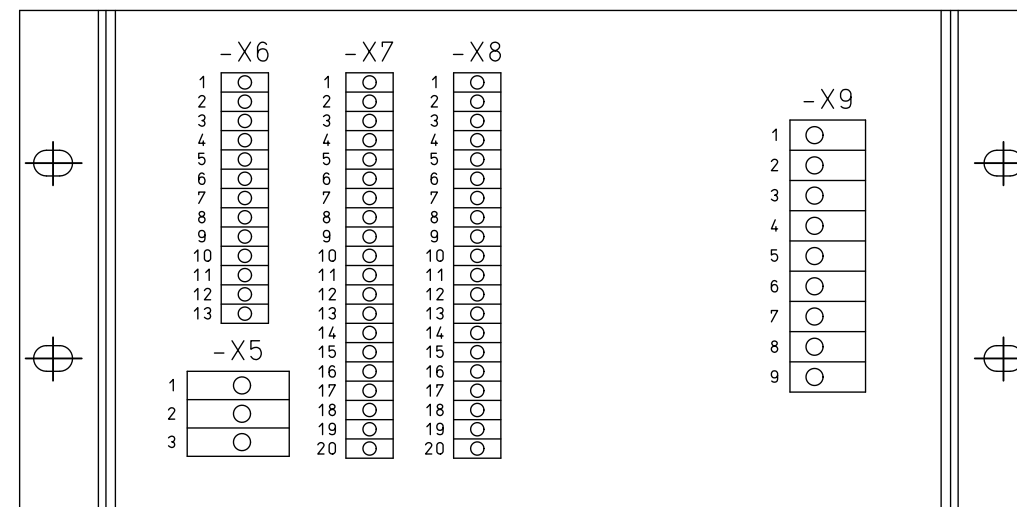
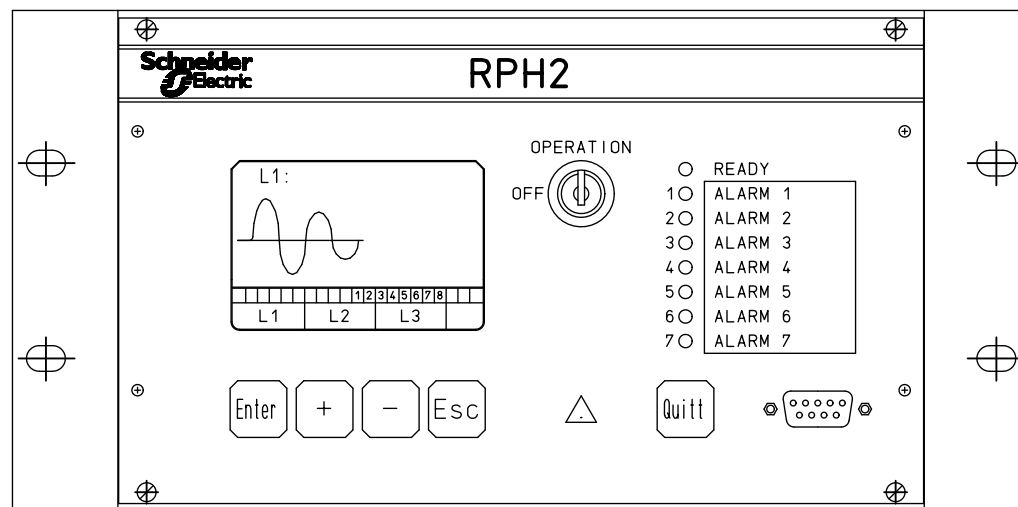

PROJEKT:
RPH2

09	-	31.05.16	Gu	DATE	1.10.96	POINT-ON-WAVE CONTROLLER RPH2 WIRING DIAGRAM		Front and rear view	Model: RPH2-2SIA3		03	
				DRAWN	THS/Höflinger							
				CHECK	THS/Samitz							
STATE	ALTERATION	DATE	NAME	STAND.		ORIG.	REPL.F.	REPL.T.		B _{A3}	58.010.111-26E	PAGE 03 16 PAGES

Alle Rechte vorbehalten.
Tous droits réservés.
All rights reserved.
© Schneider Electric Austria Ges.m.b.H.

PROJEKT:
RPH2

CB-control

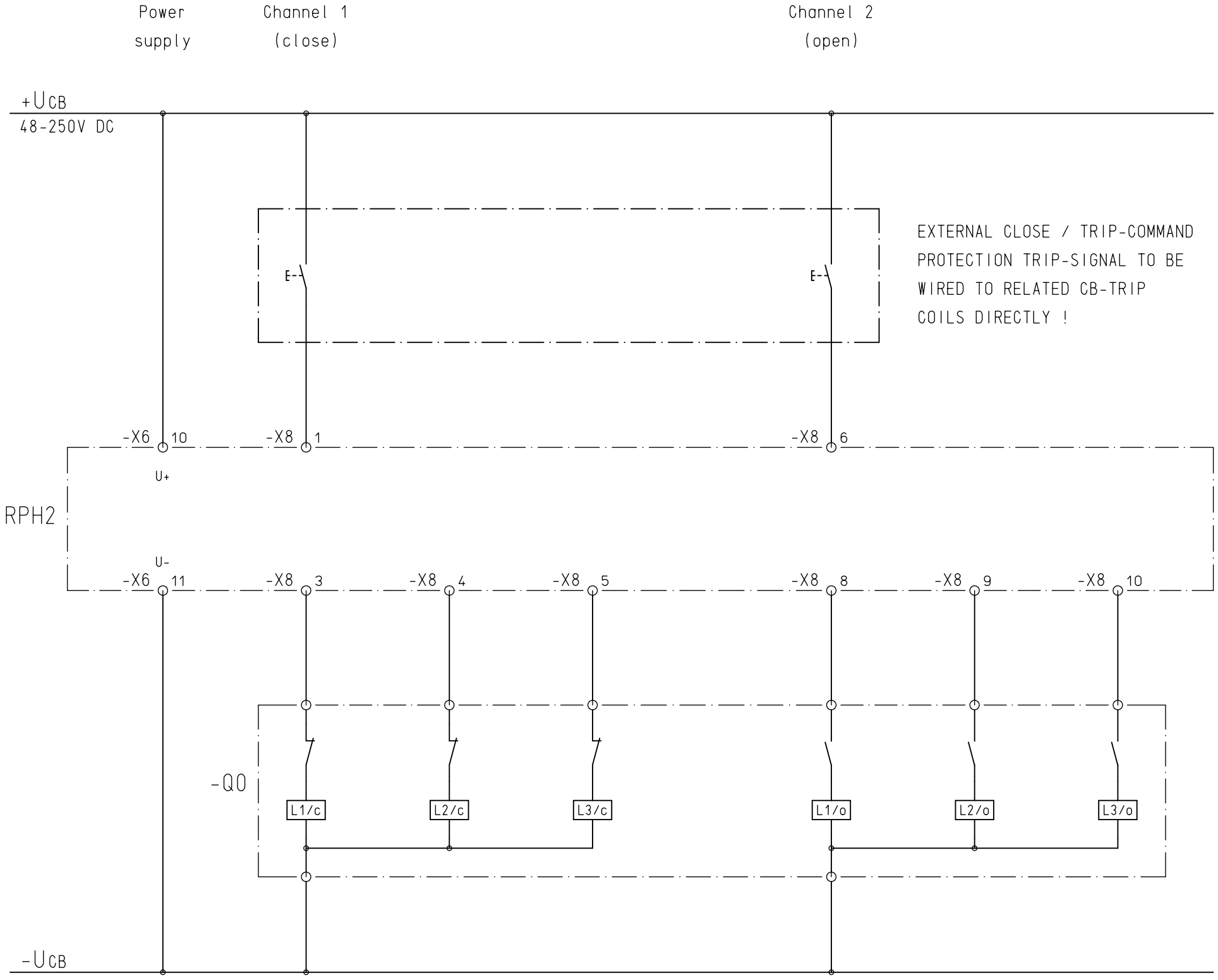

- Legend:
- Q0.....CB
 - Q8.....neutral earthing switch
 - T1.....line CT
 - T5.....busbar VT

09	-	31.05.16	Gu	DATE	1.10.96	POINT-ON-WAVE CONTROLLER RPH2 WIRING DIAGRAM		CB - control	Model: RPH2-2SIA3	= 04 + 04	
				DRAWN	THS/Höflinger						
				CHECK	THS/Samitz						
STATE	ALTERATION	DATE	NAME	STAND.		ORIG.	REPL.F.	REPL.T.	B _{A3}	58.010.111-26E	PAGE 04 16 PAGES

Alle Rechte vorbehalten.
Tous droits réservés.
All rights reserved.
© Schneider Electric Austria Ges.m.b.H.

System neutral isolated grounded Device not ready Alarm 1 CB aux contacts (Alarm reset) Optional Alarm 2 Alarm 3 Alarm 4 Alarm 5 Alarm 6 Alarm 7 real time clock sync. Optional

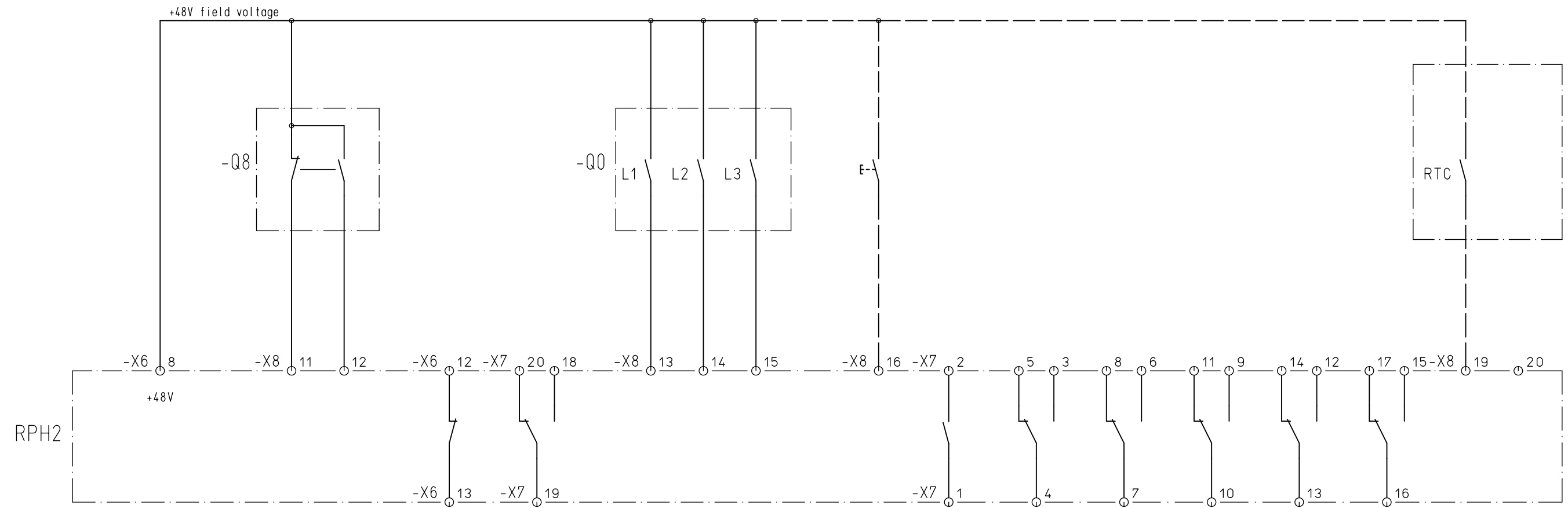

IF NO NEUTRAL EARTHING SWITCH
INSTALLED, TERMINAL -X6:8 TO
BE WIRED TO EITHER -X8:11 OR -X8:12

PROJEKT:
RPH2

09	-	31.05.16	Gu	DATE	1.10.96	POINT-ON-WAVE CONTROLLER RPH2 WIRING DIAGRAM		Monitoring inputs Alarm outputs	Model: RPH2-2SIA3		=	05		
				DRAWN	THS/Höflinger									
				CHECK	THS/Samitz									
STATE	ALTERATION	DATE	NAME	STAND.		ORIG.	REPL.F.	REPL.T.		B _{A3}	58.010.111-26E	PAGE 05 16 PAGES		

Alle Rechte vorbehalten.
Tous droits réservés.
All rights reserved.
© Schneider Electric Austria Ges.m.b.H.

PROJEKT:
RPH2

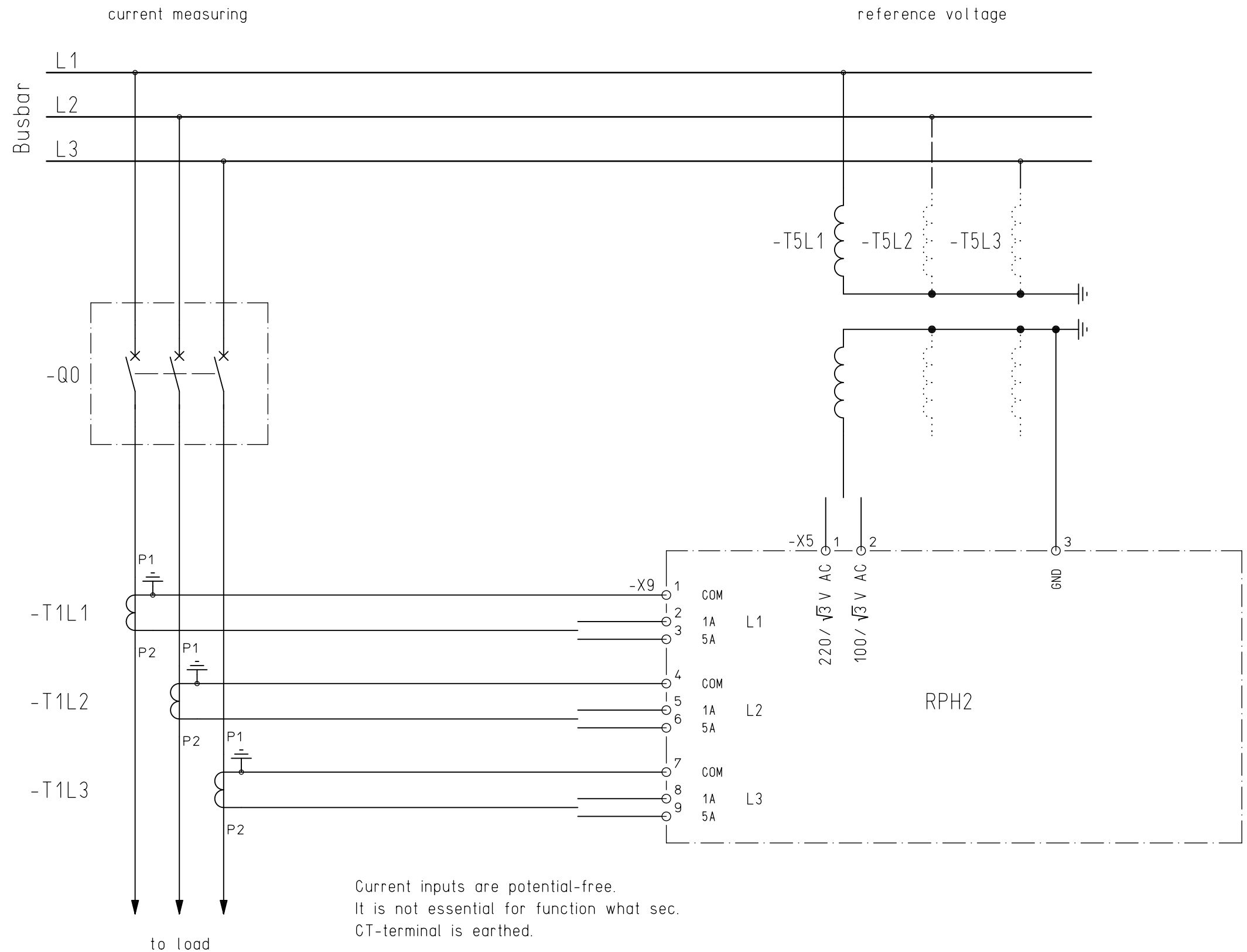

Current inputs are potential-free.
It is not essential for function what sec.
CT-terminal is earthed.

operative range of voltage input	
100/√3V AC	15...105V AC
220/√3V AC	30...230V AC

09	-	31.05.16	Gu	DATE	1.10.96	POINT-ON-WAVE CONTROLLER RPH2 WIRING DIAGRAM	Schneider Electric	Voltage inputs	Model: RPH2-2SIA3	=	06	
				DRAWN	THS/Höflinger							
				CHECK	THS/Samitz							
STATE	ALTERATION	DATE	NAME	STAND.		ORIG.	REPL.F.	REPL.T.		B _{A3}	58.010.111-26E	PAGE 06 16 PAGES

1 2 3 4 5 6 7 8

A B C D E F

A B C D E F

1 2 3 4 5 6 7 8

Alle Rechte vorbehalten.
Tous droits réservés.
All rights reserved.
© Schneider Electric Austria Ges.m.b.H.

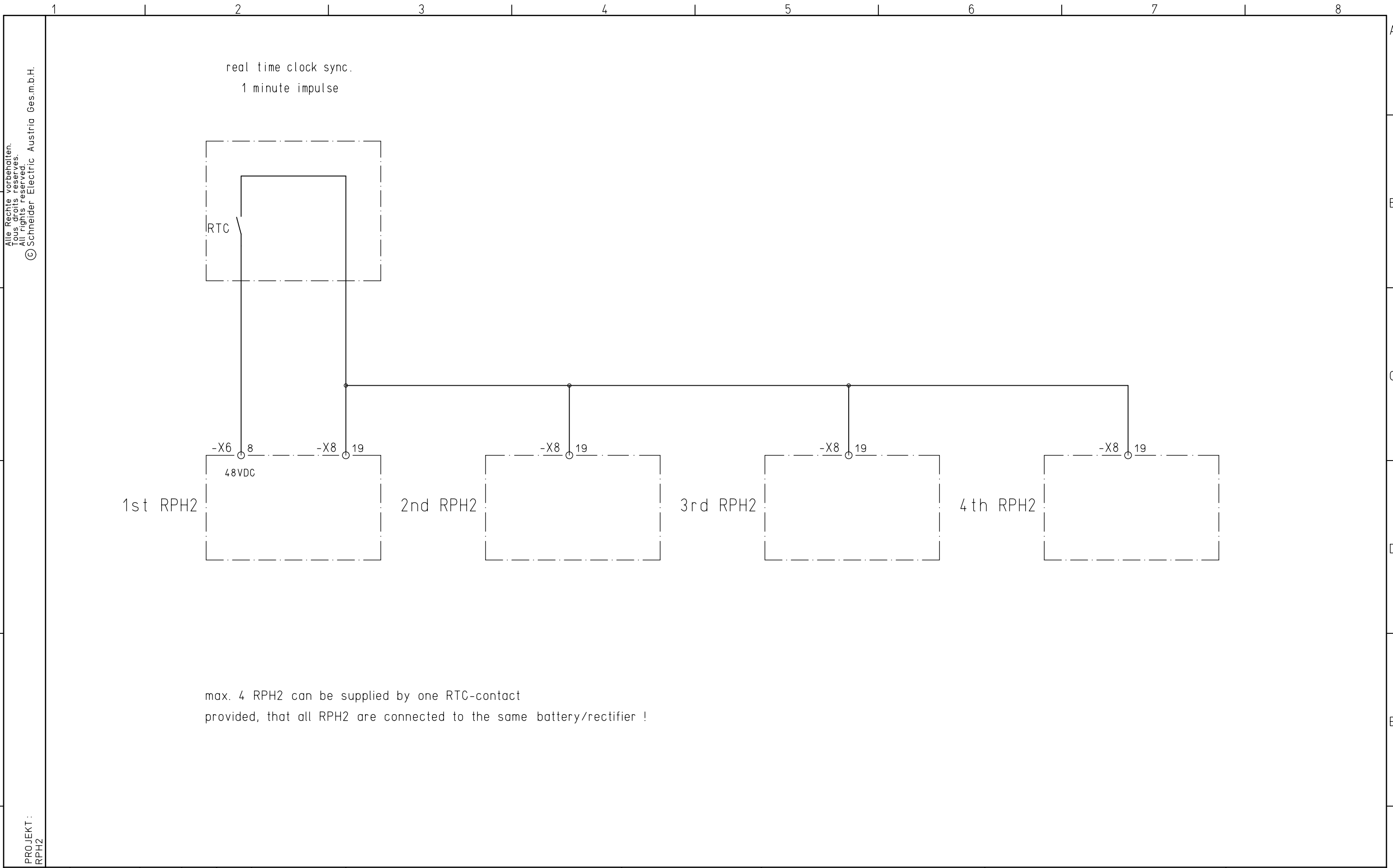

max. 4 RPH2 can be supplied by one RTC-contact
provided, that all RPH2 are connected to the same battery/rectifier !

09	-	31.05.16	Gu	DATE	1.10.96	POINT-ON-WAVE CONTROLLER RPH2 WIRING DIAGRAM		Real Time Clock Serial Connection	Model: RPH2-2SIA3		=	07		
				DRAWN	THS/Höflinger									
				CHECK	THS/Samitz									
STATE	ALTERATION	DATE	NAME	STAND.		ORIG.	REPL.F.	REPL.T.		B _{A3}	58.010.111-26E	PAGE 07 16 PAGES		

Alle Rechte vorbehalten.
Tous droits réservés.
All rights reserved.
© Schneider Electric Austria Ges.m.b.H.

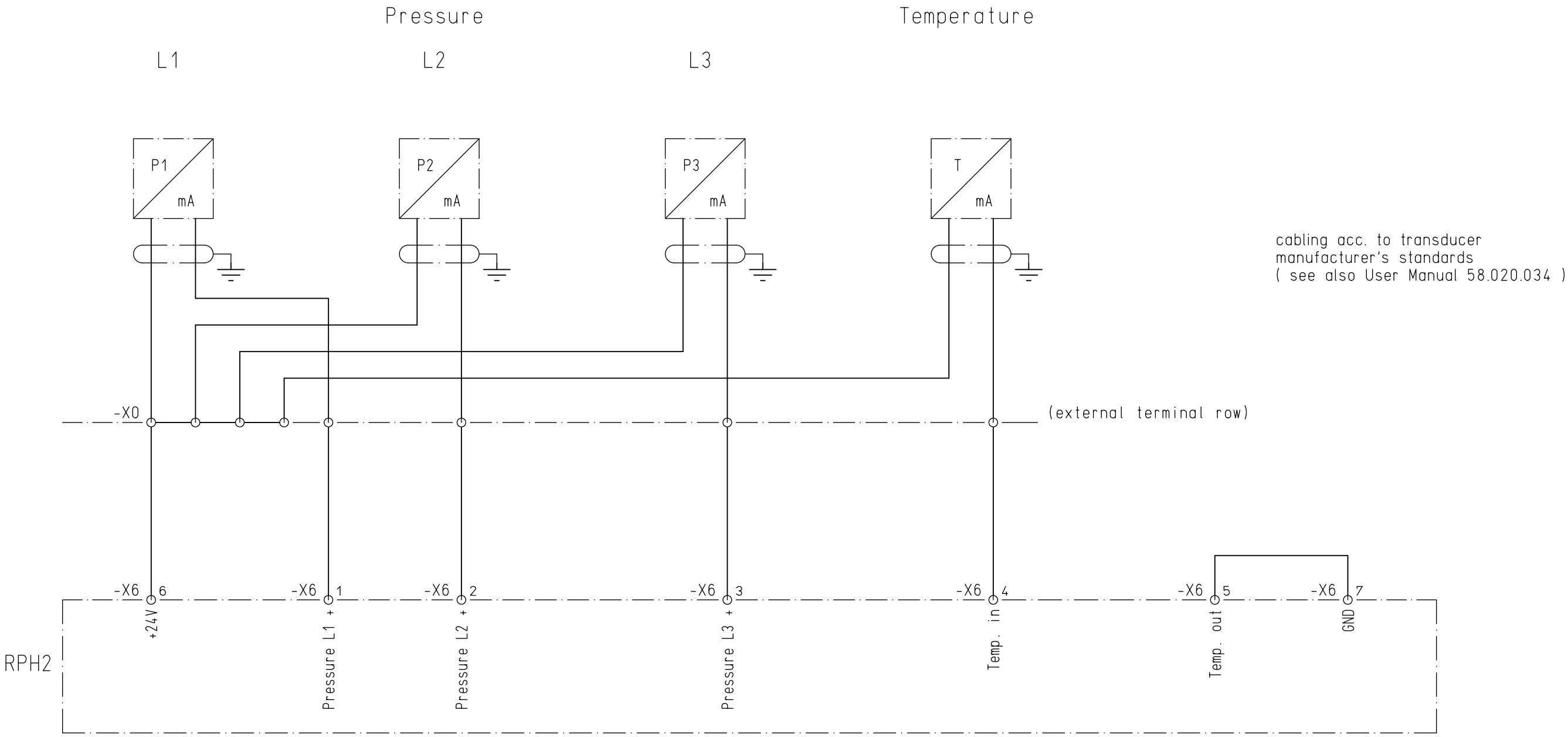

PROJEKT:
RPH2

09	-	31.05.16	Gu	DATE	1.10.96	POINT-ON-WAVE CONTROLLER RPH2 WIRING DIAGRAM		Transducer Circuits	Model: RPH2-2SIA3		=	08		
				DRAWN	THS/Höflinger								+	
				CHECK	THS/Samitz									
STATE	ALTERATION	DATE	NAME	STAND.		ORIG.	REPL.F.	REPL.T.		B _{A3}	58.010.111-26E	PAGE 08 16 PAGES		

Alle Rechte vorbehalten.
Tous droits réservés.
All rights reserved.
© Schneider Electric Austria Ges.m.b.H.

PROJEKT:
RPH2

Temperature transducer
(supplied by 1st RPH2)

2nd RPH2

3rd RPH2

max. 7 RPH2

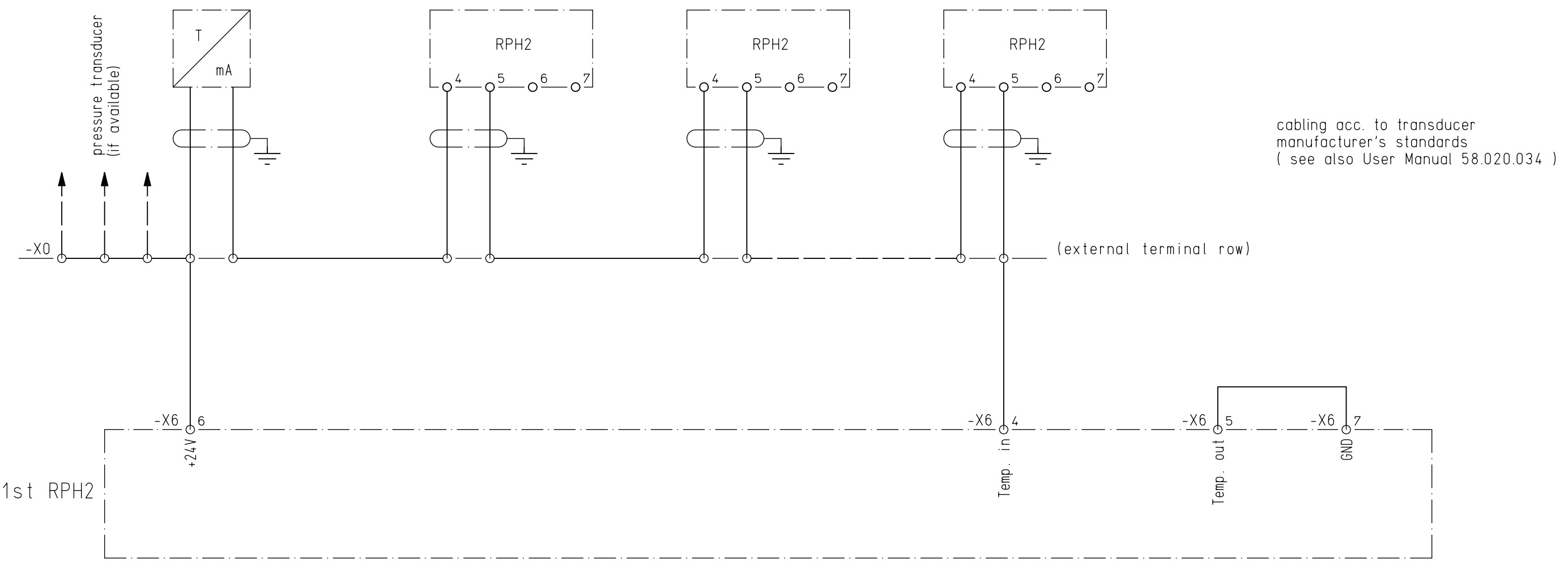

cabling acc. to transducer manufacturer's standards
(see also User Manual 58.020.034)

09	-	31.05.16	Gu	DATE	1.10.96	POINT-ON-WAVE CONTROLLER RPH2 WIRING DIAGRAM		Temp. Transducer Serial Connection	Model: RPH2-2SIA3	= 09 + 16
				DRAWN	THS/Höflinger					
				CHECK	THS/Samitz					
STATE	ALTERATION	DATE	NAME	STAND.		ORIG.	REPL.F.	REPL.T.		B _{A3} 58.010.111-26E PAGE 09 16 PAGES

Alle Rechte vorbehalten.
Tous droits réservés.
All rights reserved.
© Schneider Electric Austria Ges.m.b.H.

PROJEKT:
RPH2

CB-control

Channel 1
(close)

Channel 2
(open)

Alarm
Device failure
Bypass

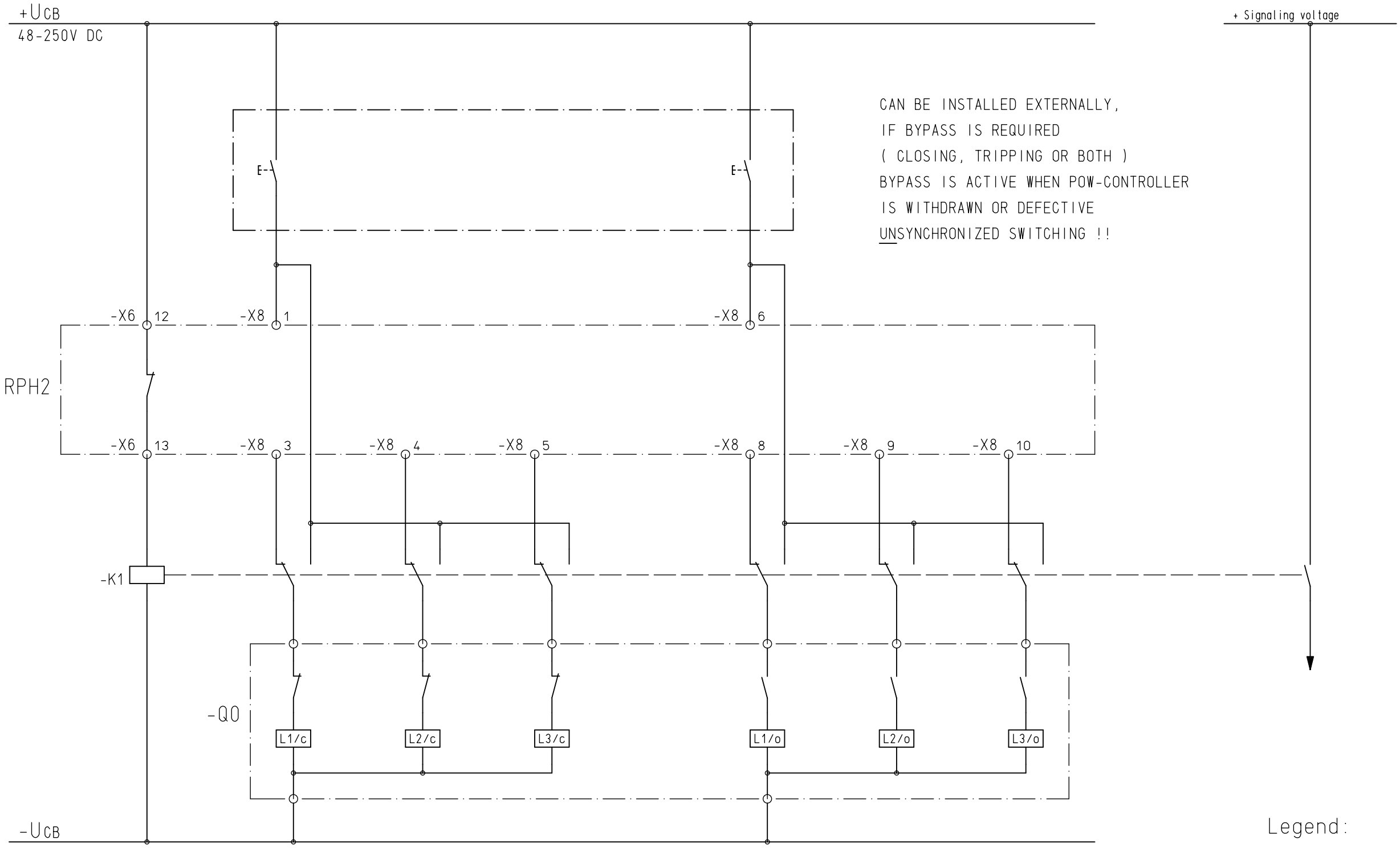

CAN BE INSTALLED EXTERNALLY,
IF BYPASS IS REQUIRED
(CLOSING, TRIPPING OR BOTH)
BYPASS IS ACTIVE WHEN POW-CONTROLLER
IS WITHDRAWN OR DEFECTIVE
UNSYNCHRONIZED SWITCHING !!

Legend:
-Q0.....CB
-K1.....aux contactor

09	-	31.05.16	Gu	DATE	1.10.96	POINT-ON-WAVE CONTROLLER RPH2 WIRING DIAGRAM	Schneider Electric	CB - control Bypass of CB - Command	Model: RPH2-2SIA3	B _{A3}	58.010.111-26E	PAGE 10 16 PAGES
				DRAWN	THS/Höflinger							
				CHECK	THS/Samitz							
STATE	ALTERATION	DATE	NAME	STAND.		ORIG.	REPL.F.	REPL.T.				

Alle Rechte vorbehalten.
Tous droits réservés.
All rights reserved.
© Schneider Electric Austria Ges.m.b.H.

PROJEKT:
RPH2

CB-control
Principle wiring for double-pole CB-control
Channel 1

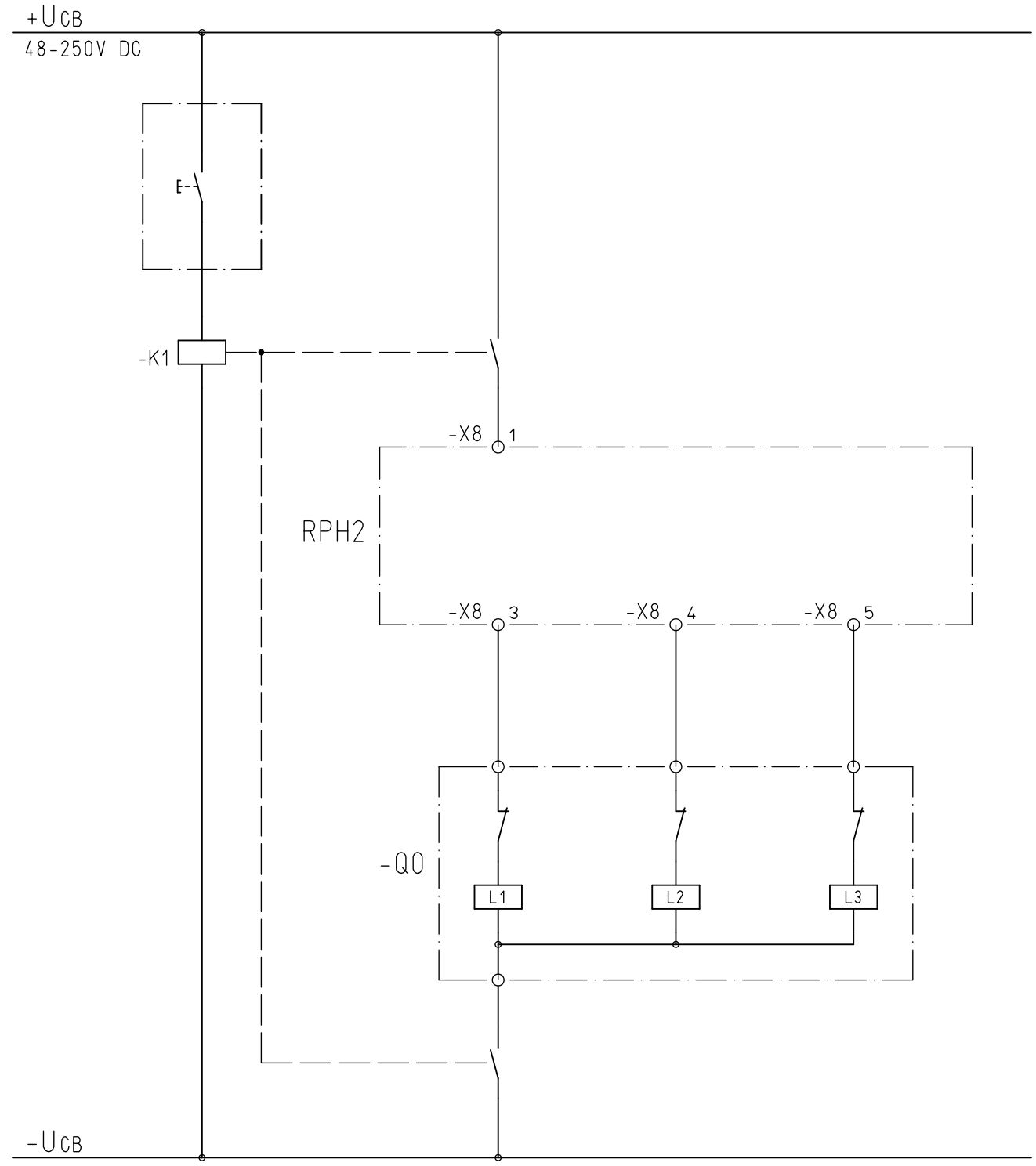

Principle of trip circuit supervision (one phase shown)

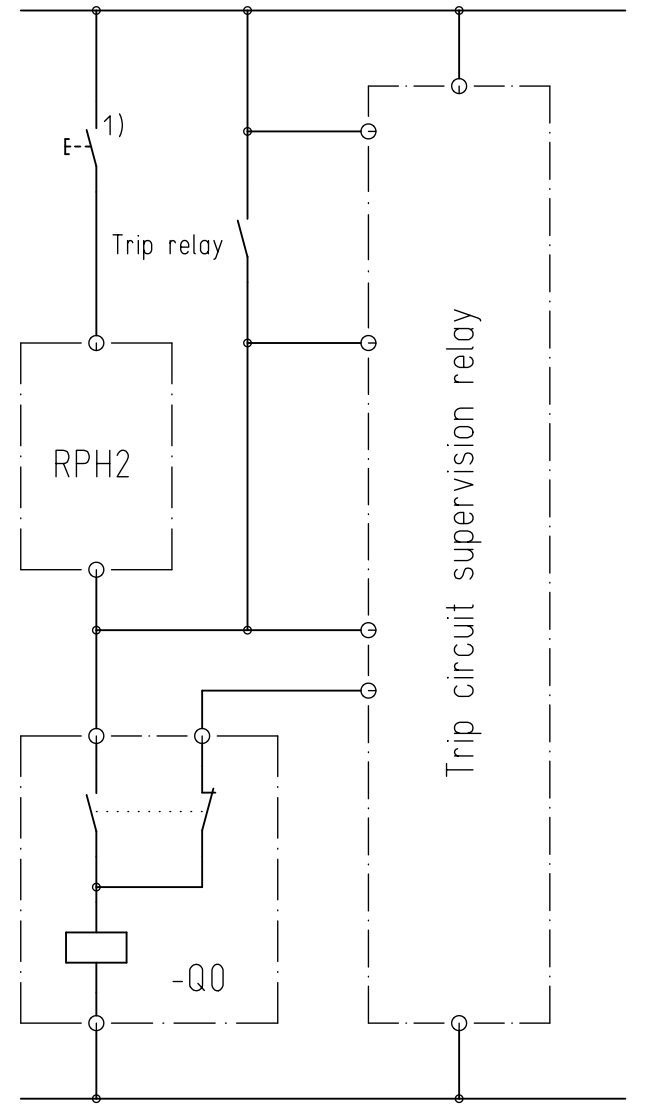

1) This contact must not be supervised !

Legend :

- Q0.....CB
- K1.....aux contactor

09	-	31.05.16	Gu	DATE	5. 5.99	POINT-ON-WAVE CONTROLLER RPH2 WIRING DIAGRAM
				DRAWN	THS/Höflinger	
				CHECK	THS/Samitz	
STATE	ALTERATION	DATE	NAME	STAND.		ORIG.



CB - control
special wiring

Model: RPH2-2SIA3

B_{A3} 58.010.111-26E

