

Ground Fault Protection

N° 2

Low Voltage Expert Guides

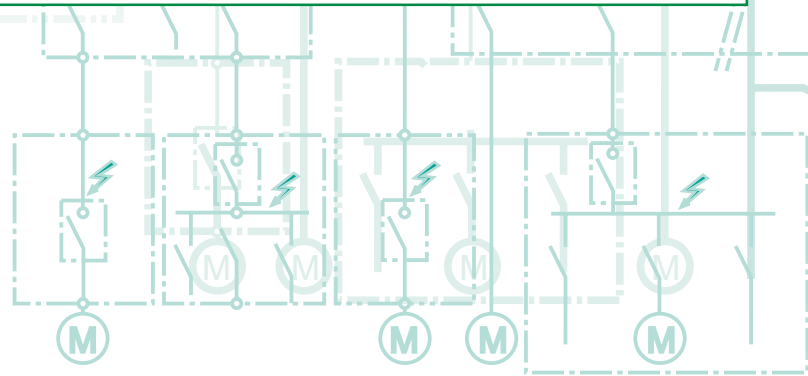
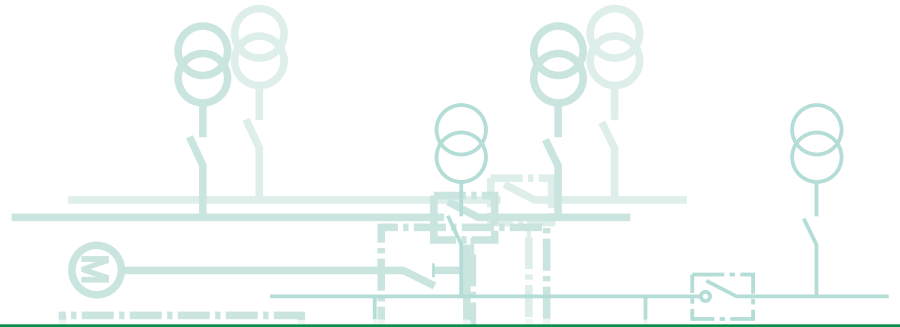

Merlin Gerin

Modicon

Square D

Telemecanique

Contents

1. The Role of “Ground Fault Protection”	3
1.1. Safety and Availability	3
1.2. Safety and Installation Standards	4
- 1.2.1. The IEC 60 364 Standard	4
- 1.2.2. The National Electric Code (NEC)	7
1.3. The Role and Functions of “Ground Fault Protection”	9
- 1.3.1. Earthing System	9
- 1.3.2. RCD and GFP	9
2. The GFP Technique	10
2.1. Implementation in the Installation	10
2.2. GFP Coordination	12
- 2.2.1. Discrimination between GFP Devices	12
- 2.2.2. Discrimination between upstream GFP Devices and downstream SCPDs	13
- 2.2.3. ZSI Logical Discrimination	14
2.3. Implementing GFP Coordination	15
- 2.3.1. Application Examples	15
2.4. Special Operations of GFP Devices	16
- 2.4.1. Protecting Generators	16
- 2.4.2. Protecting Loads	17
- 2.4.3. Special Applications	17
3. GFP Implementation	18
3.1. Installation Precautions	18
- 3.1.1. Being sure of the Earthing System	18
- 3.1.2. Being sure of the GFP Installation	18
3.2. Operating Precautions	20
- 3.2.1. Harmonic Currents in the Neutral conductor	20
- 3.2.2. Incidences on GFP Measurement	21
3.3. Applications	22
- 3.3.1. Methodology	22
- 3.3.2. Application: Implementation in a Single-source TN-S System	22
- 3.3.3. Application: Implementation in a Multisource TN-S System	23
4. Study of Multisource Systems	24
4.1. A Multisource System with a Single Earthing	24
- 4.1.1. Diagram 2	24
- 4.1.2. Diagrams 1 and 3	28
4.2. A Multisource System with Several Earthings	30
- 4.2.1. System Study	30
- 4.2.2. Solutions	31
5. Conclusion	34
5.1. Implementation	34
5.2. Wiring Diagram Study	34
- 5.2.1. Single-source System	34
- 5.2.2. Multisource / Single-ground System	35
- 5.2.3. Multisource / Multiground System	35
5.3. Summary Table	36
- 5.3.1. Depending on the Installation System	36
- 5.3.2. Advantages and Disadvantages depending on the Type of GFP	36
6. Installation and implementation of GFP solutions	37

The requirements for electrical energy power supply are:

- **safety**
- **availability.**

Installation standards take these 2 requirements into consideration:

- using techniques
- using protection specific switchgears to prevent insulation faults.

A **good coordination of these two requirements** optimizes solutions.

The Role of “Ground Fault Protection”

1.1. Safety and Availability

For the user or the operator, electrical power supply must be:

- risk free (safety of persons and goods)
- always available (continuity of supply).

These needs signify:

- in terms of safety, using technical solutions to prevent the risks that are caused by insulation faults.

These risks are:

- electrification (even electrocution) of persons
- destruction of loads and the risk of fire.

The occurrence of an insulation fault is not negligible. Safety of electrical installations is ensured by:

- respecting installation standards
- implementing protection devices in conformity with product standards (in particular with different IEC 60 947 standards).

- in terms of availability, choosing appropriate solutions.

The coordination of protection devices is a key factor in attaining this goal.

The IEC 60 364 standard defines 3 types of Earthing Systems (ES):

- TN system
- TT system
- IT system.

ES characteristics are:

- an insulation fault has varying consequences depending on the system used:
 - fault that is dangerous or not dangerous for persons
 - strong or very weak fault current.
- if the fault is dangerous, it must be quickly eliminated
- the PE is a conductor.

The **TT system** combined with **Residual Current Devices (RCD)** reduces the risk of fire.

1.2. Safety and Installation Standards

Defined by installation standards, basic principles for the protection of persons against the risk of electrical shocks are:

- the earthing of exposed conductive parts of equipment and electrical loads
- the equipotentiality of simultaneously accessible exposed conductive parts that tend to eliminate touch voltage
- the automatic breaking of electric power supply in case of voltage or dangerous currents caused by a live insulation fault current.

1.2.1. The IEC 60 364 Standard

Since 1997, IEC 364 is identified by a no.: 60 XXX, but its content is exactly the same.

1.2.1.1. Earthing Systems (ES)

The IEC 60 364 standard, in § 3-31 and 4-41, has defined and developed 3 main types of Earthing Systems (ES). The philosophy of the IEC standard is to take into account the touch voltage (U_c) value resulting from an insulation fault in each of the systems.

1/ TN-C and TN-S systems

- characteristics:
 - an insulation fault creates a dangerous touch voltage: it must be instantaneously eliminated
 - the insulation fault can be compared to a Phase-Neutral short-circuit ($I_d = \text{a few kA}$)
 - fault current return is carried out by a PE conductor. For this reason, the fault loop impedance value is perfectly controlled.

Protection of persons against indirect contact is thus ensured by Short-Circuit Protection Devices (SCPD). If the impedance is too great and does not allow the fault current to incite protection devices, it may be necessary to use Residual Current Devices (RCD) with low sensitivity ($I_S > 1 \text{ A}$).

Protection of goods is not "naturally" ensured.

The insulation fault current is strong.

Stray currents (not dangerous) may flow due to a low PE - Neutral transformer impedance.

In a TN-S system, the installation of RCDs allows for risks to be reduced:

- material destruction (RCD up to 30 A)
- fire (RCD at 300 mA).

But when these risks do exist, it is recommended (even required) to use a TT system.

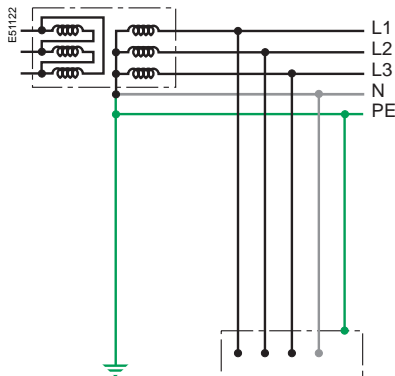

Diagram 1a - "TN-S system"

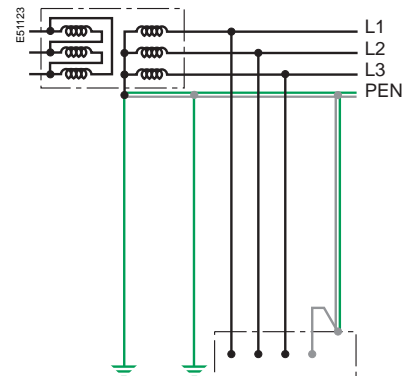

Diagram 1b - "TN-C system"

2/ TT system

■ characteristics:

- an insulation fault creates a dangerous touch voltage: it must be instantaneously eliminated
- a fault current is limited by earth resistance and is generally well below the setting thresholds of SCPDs ($I_d = \text{a few A}$).

Protection of persons against indirect contact is thus ensured by an RCD with medium or low sensitivity. The RCD causes the deenergizing of switchgear as soon as the fault current has a touch voltage greater than the safety voltage U_i .

Protection of goods is ensured by a strong natural fault loop impedance (some ω). The installation of RCDs at 300 mA reduces the risk of fire.

3/ IT system

■ characteristics:

- upon the first fault ($I_d \leq 1 \text{ A}$), the voltage is not dangerous and the installation can remain in service
- but this fault must be localised and eliminated
- a Permanent Insulation Monitor (PIM) signals the presence of an insulation fault.

Protection of persons against indirect contact is naturally ensured (no touch voltage).

Protection of goods is naturally ensured (there is absolutely no fault current due to a high fault loop impedance).

When a second fault occurs before the first has been eliminated, the installation's behaviour is analogue to that of a TN system ($I_d \gg 20 \text{ kA}$) or a TT system ($I_d \gg 20 \text{ A}$) shown below.

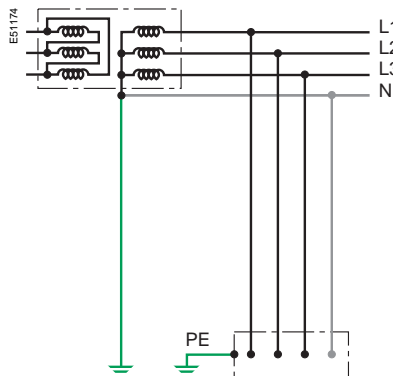

Diagram 2 - "TT system"

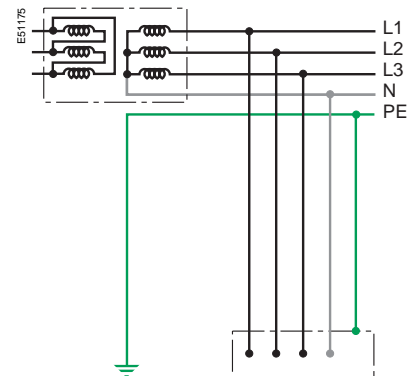

Diagram 3 - "IT system"

1.2.1.2. Protection using an RCD

RCDs with a sensitivity of 300 mA up to 30 A must be used in the TT system. Complementary protection using an RCD is not necessary for the TN or IT systems in which the PE is carried out using a conductor.

For this reason, the type of protection using an RCD must be:

- High Sensitivity (HS) for the protection of persons and against fire (30 mA / 300 mA)

- Low Sensitivity (LS) up to 30 A for the protection of belongings.

This protection can be carried out by using specific measuring toroids that cover all of the live conductors because currents to be measured are weak.

At the supply end of an installation, a system, which includes a toroid that measures the current in the PE, can even be carried out using High Sensitivity RCDs.

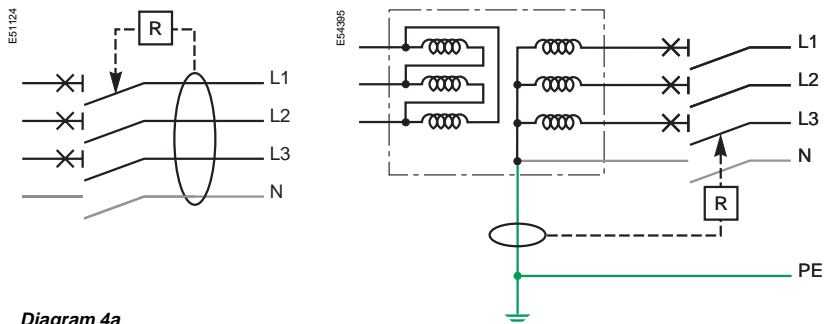
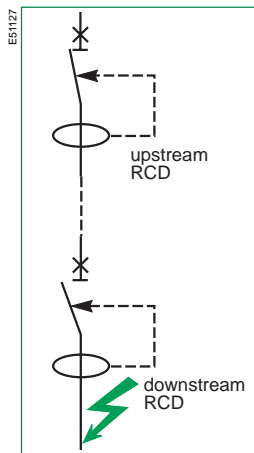

Diagram 4a

RCD Coordination

The coordination of RCD earth leakage functions is carried out using discrimination and/or by selecting circuits.



1/ Discrimination consists in only tripping the earth leakage protection device located just upstream from the fault. This discrimination can be at three or four levels depending on the installation; it is also called “vertical discrimination”. It should be both current sensitive and time graded.

■ current discrimination.

The sensitivity of the upstream device should be at least twice that of the downstream device.

In fact, IEC 60755 and IEC 60947-2 appendix B product standards define:

- non tripping of the RCD for a fault current equal to 50 % of the setting threshold
- tripping of the RCD for a fault current equal to 100 % of the setting threshold
- standardised setting values (30, 100, 300 mA and 1 A).

■ time graded discrimination.

RCDs do not limit fault current. The upstream RCD thus has an intentional delay that allows the downstream RCD to eliminate the fault independently.

Setting the upstream RCD's time delay should:

- take into account the amount of time the circuit is opened by the downstream RCD
- not be greater than the fault elimination time to ensure the protection of persons (1s in general).

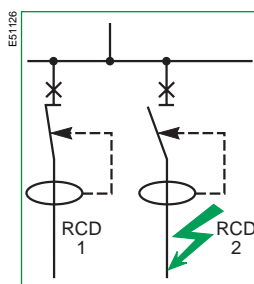

2) circuit selection consists in subdividing the circuits and protecting them individually or by group. It is also called “horizontal discrimination” and is used in final distribution.

In horizontal discrimination, foreseen by installation standards in certain countries, an RCD is not necessary at the supply end of an installation.

The National Electrical Code (NEC) defines an ES of the **TN-S** type

- non-broken Neutral conductor
- PE "conductor" made up of cable trays or tubes.

To ensure the protection of belongings and prevent the risk of fire in an electrical installation of this type, the NEC relies on techniques that use very low sensitivity RCDs called **GFP devices**.

GFP devices must be set in the following manner:

- **maximum threshold** (asymptote) at **1200 A**
- response time less than **1s** for a **fault of 3000 A** (setting of the tripping curve).

1.2.2. The National Electric Code (NEC)

1.2.2.1. Implementing the NEC

§ 250-5 of the NEC defines earthing systems of the TN-S* and IT type*, the latter being reserved for industrial or specific tertiary (hospitals) applications. The TN-S system is therefore the most used in commonplace applications.

* TN-S system is called S.G. system (Solidly Grounded) and IT system is called I.G. system (Insulated Grounding).

■ essential characteristics of the TN-S system are:

- the Neutral conductor is never broken
- the PE is carried out using a link between all of the switchgear's exposed conductive parts and the metal parts of cable racks: in general it is not a conductor
- power conductors can be routed in metal tubes that serve as a PE
- earthing of the distribution Neutral is done only at a single point - in general at the point where the LV transformer's Neutral is earthed - (see 250-5 and -21)
- an insulation fault leads to a short-circuit current.

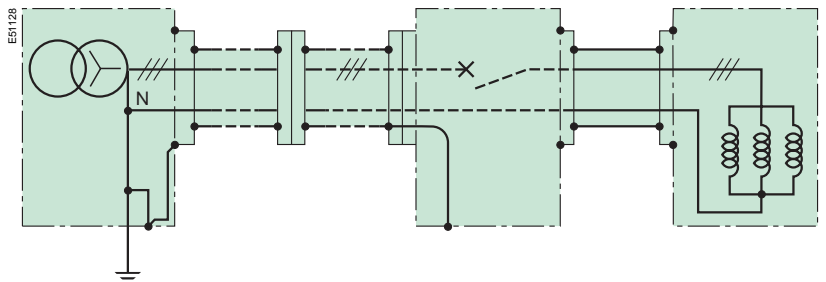

Diagram 6 - "NEC system"

Protection of persons against indirect contact is ensured:

- using RCDs in Power distribution because an insulation fault is assimilated with a short-circuit
- using High Sensitivity RCD devices ($I_{\Delta n} = 10 \text{ mA}$) at the load level.

Protection of belongings, studies have shown that global costs figure in billions of dollars per year without using any particular precautions because of:

- the possibility of strong stray current flow
- the difficultly controlled fault loop impedance.

For this reason, the NEC standard considers the risk of fire to be high. § 230 of the NEC thus develops a protection technique for "fire" risks that is based on the use of very low sensitivity RCDs. This technique is called GFP "- Ground Fault Protection". The protection device is often indicated by GFP".

■ § 230.95 of the NEC requires the use of a GFP device at least at the supply end of a LV installation if:

- the Neutral is directly earthed
- $150 \text{ V} < \text{Phase-to-Neutral voltage} < 600 \text{ V}$
- $I_{\text{Nominal}} \text{ supply end device} > 1000 \text{ A}$.

■ the GFP device must be set in the following manner:

- maximum threshold (asymptote) at 1200 A
- response time less than 1s for a fault of 3000 A (setting of the tripping curve).

Even though the NEC standard requires a maximum threshold of 1200 A, it recommends:

- settings around 300 to 400 A
- on the downstream outgoer, the use of a GFP device that is set (threshold, time delay) according to the rules of discrimination in paragraph 2.2.

■ exceptions for the use of GFP device are allowed:

- if continuity of supply is necessary and the maintenance personnel is well trained and omnipresent
- on emergency set generators
- for fire fighting circuits.

1.2.2.2. Protection using GFP Devices

GFP as in NEC § 230.95

These functions are generally built into an SCPD (circuit-breaker).

Three types of GFP are possible depending on the measuring device installed:

■ “Residual Sensing” RS

The “insulation fault” current is calculated using the vectorial sum of currents of instrument CT* secondaries .

*The CT on the Neutral conductor is often outside the circuit-breaker.

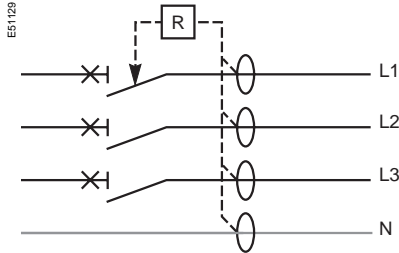

Diagram 7a - “RS system”

■ “Source Ground Return” SGR

The “insulation fault current” is measured in the Neutral - Earth link of the LV transformer. The CT is outside of the circuit-breaker.

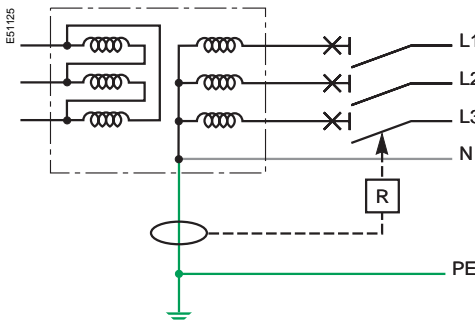

Diagram 7b - “SGR system”

■ “Zero Sequence” ZS

The “insulation fault” is directly calculated at the primary of the CT using the vectorial sum of currents in live conductors. This type of GFP is only used with weak fault current values.

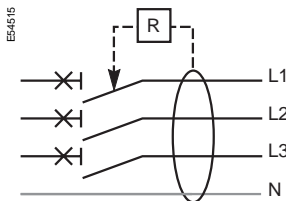

Diagram 7c - “ZS system”

1.2.2.3. Positioning GFP Devices in the Installation

GFP devices are used for the Protection against the risk of fire.

type/installation level	main-distribution	sub-distribution	comments
Source Ground Return (SGR)	<input type="checkbox"/>		used
Residual sensing (RS) (SGR)	<input type="checkbox"/>	■	often used
Zero Sequence (SGR)	<input type="checkbox"/>	■	rarely used

possible ■ recommended or required

To ensure protection against fire:

- the NEC defines the use of an RCD with very Low Sensitivity called GFP
- IEC 60 364 standard uses the characteristics of the TT system combined with Low or High Sensitivity RCDs.

These protections use the same principle: **fault current measurement** using:

- a sensor that is sensitive to earth fault or residual current (Earth fault current)
- a measuring relay that compares the current to the setting threshold
- an actuator that sends a tripping order to the breaking unit on the monitored circuit in case the threshold setting has been exceeded.

1.3. The Role and Functions of “Ground Fault Protection”

This type of protection is defined by the NEC (National Electrical Code) to ensure protection against fire on electrical power installations.

1.3.1. Earthing System

IEC standard:

- uses ES characteristics to manage the level of fault currents
- for this reason, only recommends fault current measuring devices that have very weak setting values (RCD with threshold, in general, < 500 mA).

The NEC:

- defines TN-S and IT systems
- recommends fault current protection devices with high setting values (GFP with threshold, in general, > 500 A) for the TN-S system.

Earthing System	TN-C System	TN-S System	TT System	IT-1st fault System
fault current	strong Id ≤ 20 kA	strong Id ≤ 20 kA	medium Id ≤ 20 A	weak Id ≤ 0,1 A
use of ES				
■ IEC 60 364	<input type="checkbox"/>	<input type="checkbox"/> <input type="checkbox"/> <input type="checkbox"/>	<input type="checkbox"/> <input type="checkbox"/>	<input type="checkbox"/>
■ NEC	forbidden	<input type="checkbox"/> <input type="checkbox"/> <input type="checkbox"/>	forbidden	<input type="checkbox"/>
fire :				
■ for IEC 60 364	not recommended	not recommended	recommended + RCD 300 mA	
■ for NEC	not applicable	GFP 1200 A	not applicable	

rarely used used often used

1.3.2. RCD and GFP

The insulation fault current can:

- either, cause tripping of Short-Circuit Protection Devices (SCPD) if it is equivalent to a short-circuit
- or, cause automatic opening of circuits using specific switchgear:
 - called RCD if the threshold setting value has High Sensitivity (HS) 30 mA or Low Sensitivity (LS) up to 30 A
 - called GFP for very Low Sensitivity setting values (> 100 A).

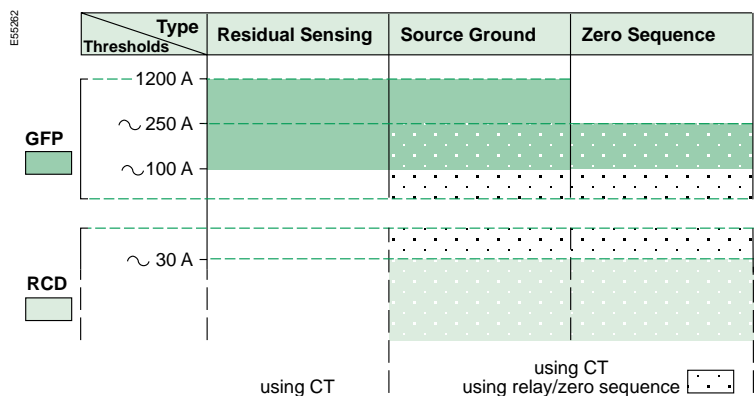

Implementing GFP

The measurement should be taken:
 ■ either, on all of the live conductors (3 Phases + Neutral if it is distributed).

GFP is of the RS or Z type.

■ or, on the PE conductor. GFP is of the SGR type.

Low Sensitivity GFP can only operate in the TN-S system.

The GFP Technique

2.1. Implementation in the Installation

Analysis of diagram 8 shows three levels.

A/ At the MSB level, installation characteristics include:

- very strong nominal currents (> 2000 A)
- strong insulation fault currents
- the PE of the source protection is easily accessible.

For this reason, the GFP device to be placed on the device's supply end is of the Residual Sensing or Source Ground Return type.

The continuity of supply requires total discrimination of GFP protection devices in case of downstream fault.

At this level, installation systems can be complex: multisource, etc. Management of installed GFP devices should take this into account.

B/ At the intermediate or sub-distribution switchboard, installation characteristics include:

- high nominal currents (from 100 A to 2000 A)
- medium insulation fault currents
- the PEs of protection devices are not easily accessible.

For this reason, GFP devices are of the Residual or Zero Sequence type (for their weak values).

Note: discrimination problems can be simplified in the case where insulation transformers are used.

C/ At the load level, installation characteristics include:

- weak nominal currents (< 100 A)
- weak insulation fault currents
- the PEs of protection devices are not easily accessible.

Protection of belongings and persons is carried out by RCDs with HS or LS thresholds.

The continuity of supply is ensured:

- using horizontal discrimination at the terminal outgoer level: an RCD on each outgoer
- using vertical discrimination near the protection devices on the upstream sub-distribution switchboard (easily done because threshold values are very different).

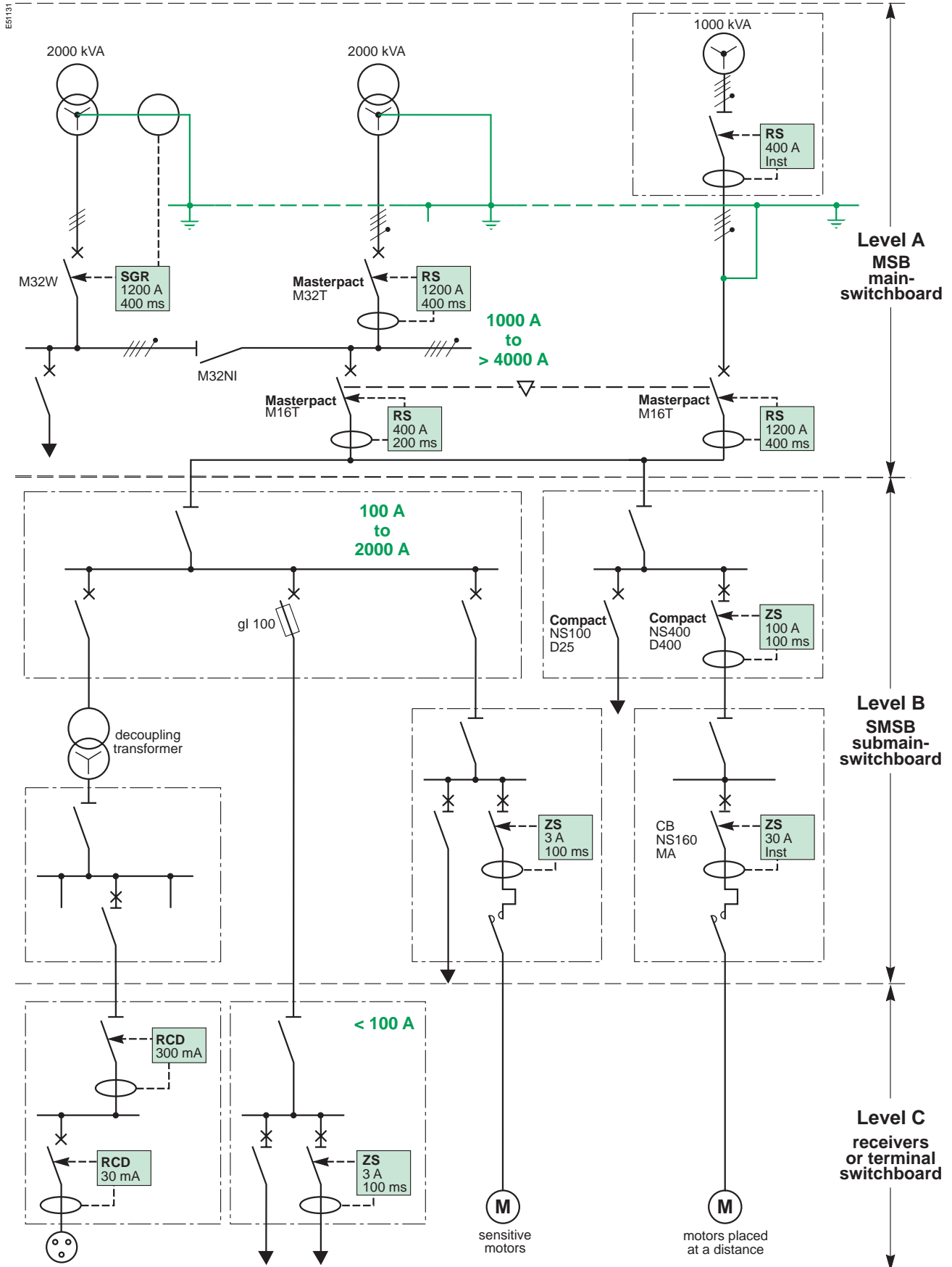

Diagram 8 - "general system"

Discrimination between Ground Fault Protection Devices must be current sensing and time graded. This discrimination is made between:

- upstream GFP and downstream GFP devices
- upstream GFP devices and short delay tripping of downstream devices.

“ZSI” logic discrimination guarantees the coordination of upstream and downstream devices. It requires a pilot wire between devices.

2.2. GFP Coordination

The NEC 230 § 95 standard only requires Ground Fault protection using a GFP device on the supply end device to prevent the risk of fire. However, insulation faults rarely occur on MSB busbars, rather more often on the middle or final part of distribution. Only the downstream device located just above the fault must react so as to avoid deenergisation of the entire installation.

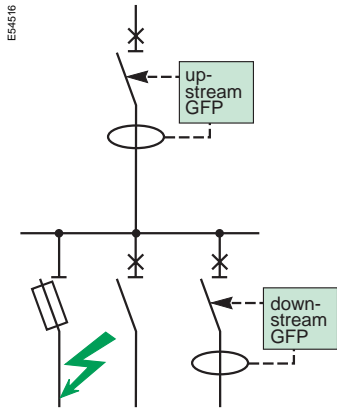

Diagram 9

The upstream GFP device must be coordinated with the downstream devices. Device coordination shall be conducted between:

- the upstream GFP device and any possible downstream GFP devices
- the upstream GFP device and the downstream SCPDs, because of the GFP threshold setting values (a few hundred amps), protection using GFP devices can interfere with SCPDs installed downstream.

Note: the use of transformers, which ensure galvanic insulation, Earthing System changes or voltage changes, solve discrimination problems (see § 2.4.3).

2.2.1. Discrimination between GFP Devices

Discrimination Rules: discrimination is of the current sensing and time graded type

These two types of discrimination must be simultaneously implemented.

■ **current sensing discrimination**

Threshold setting of upstream GFP device tripping is greater than that of the downstream GFP device. Because of tolerances on the settings, a 30 % difference between the upstream and downstream thresholds is sufficient.

■ **time graded discrimination**

The intentional time delay setting of the upstream GFP device is greater than the opening time of the downstream device. Furthermore, the intentional time delay given to the upstream device must respect the maximum time for the elimination of insulation faults defined by the NEC § 230.95 (i.e. 1s for 3000 A).

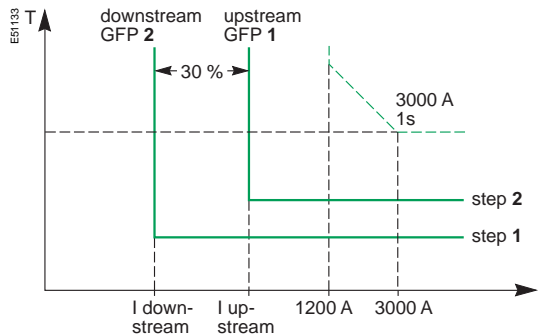
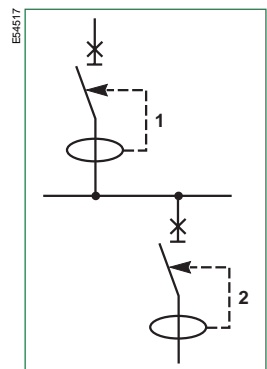

Diagram 10 - coordination between GFP devices



2.2.2. Discrimination between upstream GFP Devices and downstream SCPDs

Discrimination Rules between GFP Devices and downstream fuses

Because of threshold setting values of GFP devices (a few hundred amps), protection using GFP devices can interfere with protection using fuse devices installed downstream in case of an Earth fault.

If downstream switchgear is not fitted out with a Ground Fault Protection device, it is necessary to verify that the upstream GFP device setting takes the downstream fuse blowing curve into account.

A study concerning operating curves shows that total discrimination is ensured with:

- a ratio in the realm of 10 to 15 between the upstream GFP setting threshold and the rating of downstream fuses
- an intentional delay of the upstream GFP device that is greater than the breaking time of the downstream device.

A function of the $I^2t = \text{constant}$ type on the GFP device setting allows the discrimination ratio to be slightly improved.

The ratio can be greatly reduced by using a circuit-breaker thanks to the possibility of setting the magnetic threshold or the short delay of the downstream circuit-breaker.

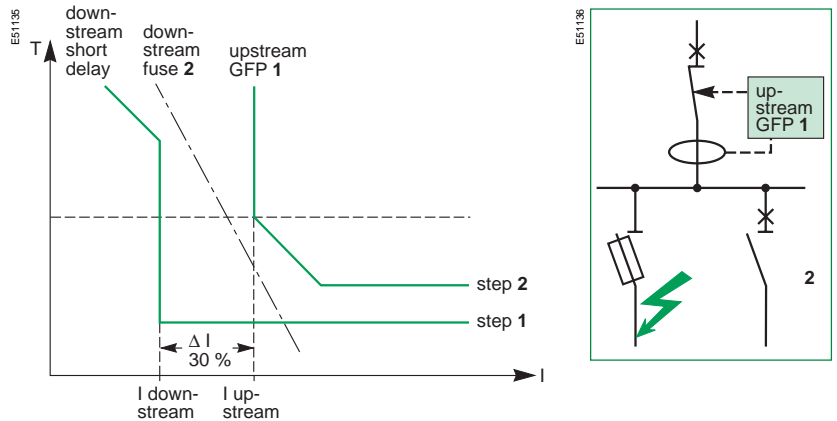

Diagram 11 - coordination between upstream GFP device and downstream devices

Discrimination Rules between GFP devices and circuit-breakers

- the above condition is equivalent to a GFP device setting at 1.5 times that of magnetic protection or time delay of the downstream circuit-breaker
- if this condition is not verified and so that it may be executed:
 - lower the magnetic setting threshold while being careful of nuisance tripping on the downstream outgoer dealt with (especially on the motor feeder)
 - raise the GFP device threshold while being careful of keeping the installation's protection against stray currents because this solution allows the flow of stronger currents.

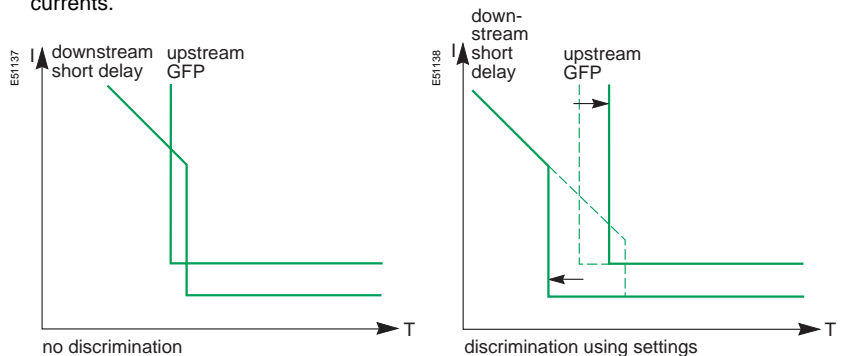

Diagram 12a

Diagram 12b

2.2.3. ZSI Logical Discrimination

ZSI = “ Zone Selective Interlocking”

Recommended and greatly used in the USA, it is installed using a pilot wire that links each of the downstream GFP device functions to the upstream GFP device function.

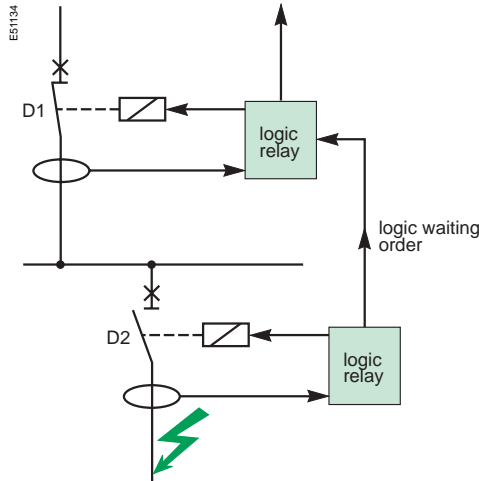

Upon fault, the relay located the nearest to the Earth fault (for ex. R1) sees the fault, sends a signal to the upstream relay (R2) to indicate to it that it has seen the fault and that it will immediately eliminate it. R2 receives this message, sees the fault but waits for the signal from R1 and also sends a signal to R3, etc. The R2 relay only trips after a time delay (some ten ms) if the fault is not eliminated by R1. (See examples 1 and 2).

Diagram 13a - ZSI discrimination

This technique allows:

- discrimination on 3 or more levels to be easily carried out
- great stress on the installation, which are linked to time-delayed tripping of protection devices, to be eliminated upon fault that is directly on the upstream busbars. **All protection devices are thus instantaneous.**

A pilot wire between all the protection devices dealt with is necessary for this technique.

Example 1:

- D1 to D3 circuit-breakers are fitted out with a CU that allows the implementation of logic discrimination:
- an insulation fault occurs at point C and causes a fault current of 1500 A.

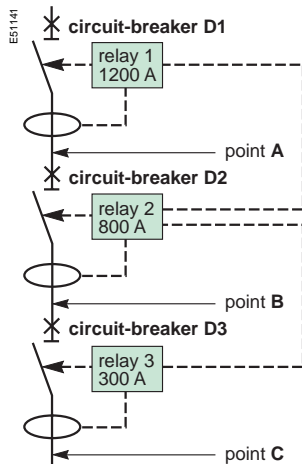

- relay no. 3 (threshold at 300 A) immediately gives the tripping order to the circuit-breaker (D3) of the outgoer dealt with:
- relay no. 3 also sends a signal to relay no. 2, which also detected the fault (threshold at 800 A), and temporarily cancels the tripping order to circuit-breaker D2 for a few hundred milliseconds, the fault elimination time needed by circuit-breaker D3
- relay no. 2 in turn sends a signal to relay no. 1
- relay no. 2 gives the order to open circuit-breaker D2 after a few hundred milliseconds only if the fault continues, i.e. if circuit-breaker D3 did not open
- id, relay no. 1 gives the order to open circuit-breaker D1 a few hundred milliseconds after the fault occurred only if circuit-breakers D2 and D3 did not open.

Diagram 13b - ZSI application

Example 2:

- an insulation fault occurs at point A and causes a fault current of 1500 A
- relay no. 1 (threshold at 1200 A) immediately gives the tripping order to circuit-breaker (A) that has not received a signal from the downstream relays
- instantaneous tripping of D1 **allows stresses on busbars to be greatly reduced.**

Discrimination rules between GFP devices and circuit-breakers implies a GFP device to be set at 1.5 times that of magnetic protection or short delay of the downstream circuit-breaker.

2.3. Implementing GFP Coordination

2.3.1. Application Examples

2.3.1.1. Discrimination between GFP devices

Example 1:

- circuit-breaker D1 is fitted out with a GFP device of the SGR type set at 1200 A index II (i.e. $\Delta t = 140$ ms)
- circuit-breaker D2 is fitted out with a GFP2 device of the RS type set at 400 A instantaneous
- an insulation fault occurs in B and causes a fault current of 1500 A:
- a study concerning tripping curves shows that the 2 relays “see” the fault current. But only GFP2 makes its device trip instantaneously
- discrimination is ensured if the total fault elimination time Δt by D2 is less than the time delay Δt of D1.

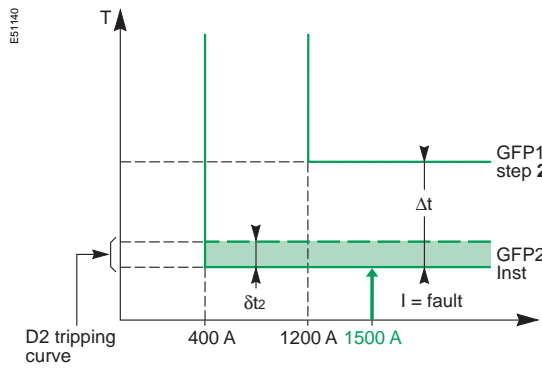

Diagram 14a - tripping curves

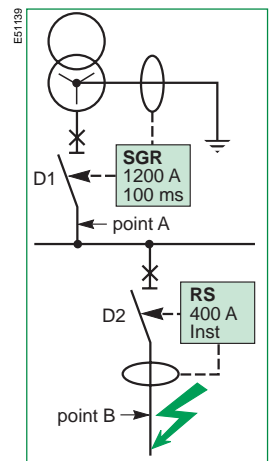

Diagram 12b

Example 2:

- an insulation fault occurs in A and causes a fault current of 2000 A:
- circuit-breaker D1 eliminates it after a time delay Δt
- the installation undergoes heat stress from the fault during time delay Δt and the fault elimination time Δt .

2.3.1.2. Discrimination between upstream GFP devices and downstream SCPDs

Example 1:

- the upstream circuit-breaker D1 is fitted out with a GFP device that has a threshold set at $1000 \text{ A} \pm 15\%$ and a time delay at 400ms:
 - circuit-breaker D2 has a rating of 100 A that protects distribution circuits. The short delay setting of D2 is at $10 I_n$ i.e. $1000 \text{ A} \pm 15\%$
 - an insulation fault occurs at point B causing a fault current I_d .
 - a study concerning tripping curves shows overlapping around the magnetic threshold setting value (1000 A i.e. $10 I_n \pm 15\%$) thus a loss of discrimination.
- By lowering the short delay threshold to $7 I_n$, discrimination is reached between the 2 protection devices whatever the insulation fault value may be.

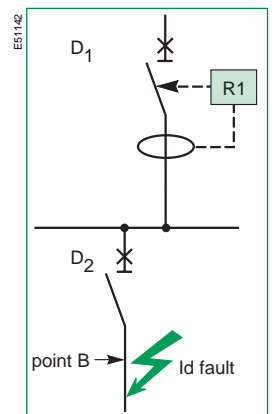

Diagram 14b

Protection using GFP devices can also be used to:

- protect generators
- protect loads.

The use of transformers on part of the installation allows insulation faults to be confined.

Discrimination with an upstream GFP device is naturally carried out.

2.4. Special Operations of GFP Devices

2.4.1. Protecting Generators

An insulation fault inside the metal casing of a generating set may severely damage the generator of this set. The fault must be quickly detected and eliminated. Furthermore, if other generators are parallelly connected, they will generate energy in the fault and may cause overload tripping. Continuity of supply is no longer ensured.

For this reason, a GFP device built-into the generator's circuit allows:

- the fault generator to be quickly disconnected and service to be continued
- the control circuits of the fault generator to be stopped and thus to diminish the risk of deterioration.

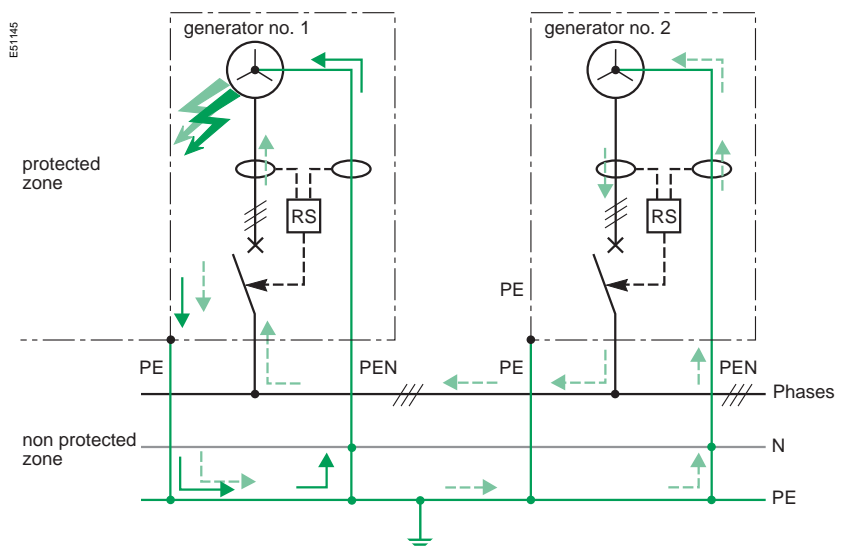

Diagram 15 - "generator protection"

This GFP device is of the "Residual sensing" type and is to be installed closest to the protection device as shown in a TN-C system, in each generator set with earthed exposed conducted parts using a separate PE:

- upon fault on generator no. 1:
 - an earth fault current is established in PE1 $I_{d1} + I_{d2}$ due to the output of power supplies 1 and 2 in the fault
 - this current is seen by the GFP1 device that gives the instantaneous disconnection order for generator 1 (opening of circuit-breaker D1)
 - this current is not seen by the GFP2 device. Because of the TN-C system.

This type of protection is called "restricted differential". Installed GFP devices only protect power supplies.

GFP is of the "Residual sensing" RS type.
GFP threshold setting: from 3 to 100 A depending on the GE rating.

2.4.2. Protecting Loads

A weak insulation fault in motor winding can quickly develop and finish by creating a short-circuit that can significantly deteriorate even destroy the motor. A GFP device with a low threshold (a few amps) ensures correct protection by deenergizing the motor before severe damage occurs.

GFP is of the "Zero Sequence" type.
GFP threshold setting: from 3 to 30 A depending on the load types.

2.4.3. Special Applications

It is rather common in the USA to include LV transformers coupled ΔY in the power distribution:

- to lower the voltage
- mix earthing systems
- ensure galvanic insulation between the different applications, etc.

This transformer also allows the discrimination problem between the upstream GFP device and downstream devices to be overcome. Indeed, fault currents (earth fault) do not flow through this type of coupling.

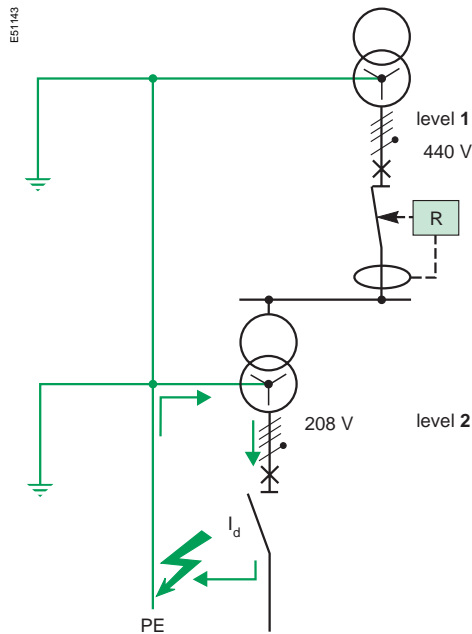

Diagram 16 - "transformers and discrimination"

GFP Implementation

Correct implementation of GFP devices on the network consists of:

- good protection against insulation faults
- tripping only when it is necessary.

The correct implementation of GFP devices depends on:

- the installed ES. The ES must be of the TN-S type
- the measurement carried out
- not forgetting the Neutral conductor current
- the correct wiring of an external CT, if used, to the primary as well as to the secondary,
- a good coordination (discrimination) between devices.

3.1. Installation Precautions

3.1.1. Being sure of the Earthing System

GFP is protection against fire at a high threshold (from a few dozen up to 1200 Amps):

- in an IT and/or TT type system, this function is not necessary: insulation fault currents are naturally weak, - less than a few Amps (see § 1.2.1) -
- in a TN-C system, PE conductors and Neutral are the same: for this reason, insidious and dangerous insulation fault currents cannot be discriminated from a normal Neutral current.

The system must be of the TN-S type.

The GFP function operates correctly only:

- with a true PE conductor, i.e. a protection conductor that only carries fault currents
- with an Earthing System that favors, upon insulation fault, the flow of a strong fault current.

3.1.2. Being sure of the GFP Installation

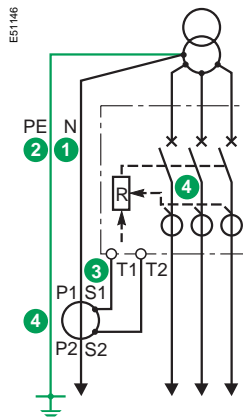

Diagram 17 - "RS system": upstream and downstream power supply

Residual Sensing System

First, it is necessary to verify that:

- all of the live conductors, including the Neutral conductor, are controlled by (the) measuring toroid(s)
- the PE conductor is not in the measuring circuit
- the Neutral conductor is not a PEN, or does not become one by system upgrading (case of multisource)
- the current measurement in the Neutral (if it is done by a separate CT) is carried out using the correct polarity (primary and secondary) so that the protection device's electronics correctly calculate the vectorial sum of Phases and Neutral currents
- the external CT has the same rating as the CT of phases

Note 1: the use of a 4P circuit-breaker allows problems to be resolved.

Note 2: the location of the measuring CT on the neutral conductor is independent from the type of switchgear power supply:

- upstream power supply or
- downstream power supply.

E54618

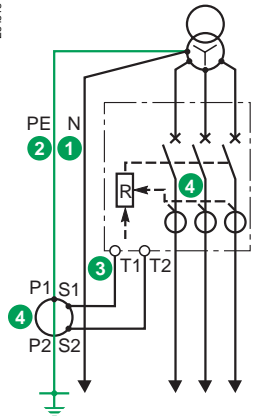

Source Ground Return System

It is necessary to ensure that:

- measurement is carried out on a PE conductor and not on a PEN ↗
- the precautions concerning the CT polarity described above are taken into account (even if the measurement is carried out by a single CT, it may subsequently be coupled to other CTs) ➤
- the external CT has the same rating as the CT of phases ↗.

Diagram 18 - "SGR system": upstream and downstream power supply

Coupling Measuring CTs

So as to correctly couple 2 measuring CTs or to connect an external CT, it is necessary:

- in all cases:
 - to verify that they all have the same rating
 - to verify polarity (primary as well as secondary).
- in the case of coupling at the wiring level of secondaries, it is suggested:
 - to put them in short-circuit when they are open (disconnected)
 - to connect terminals with the same markers together (S1 to S1 and S2 to S2)
 - Earth the secondary terminal S2 only one of the CTs
 - to carry out the coupling/decoupling functions on the links of S1 terminals.

E54619

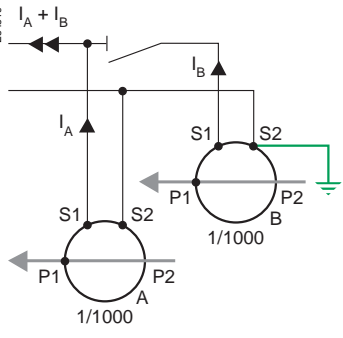

Diagram 19a - external CT coupling

During operation, the TN-S system must be respected.

A “multisource/multigrounding” installation must be carefully studied because the upstream system may be a TN-C and the Neutral conductor a PEN.

3.2. Operating Precautions

The main problem is ensuring that the TN-S system does not transform into a TN-C system during operation. This can be dangerous and can disturb the Neutral conductor in the case of strong current.

3.2.1. Harmonic Currents in the Neutral conductor

Strong natural current flow in the Neutral conductor is due to some non-linear loads that are more and more frequent in the electrical distribution (1):

- computer system cut-off power supply (PC, peripherals, etc.)
- ballast for fluorescent lighting, etc.

These loads generate harmonic pollution that contributes to making a strong earth fault current flow in the Neutral conductor.

These harmonic currents have the following characteristics:

- being thirds harmonic or a multiple of 3
- being permanent (as soon as loads are supplied)
- having high amplitudes (in any case significantly greater than unbalanced currents).

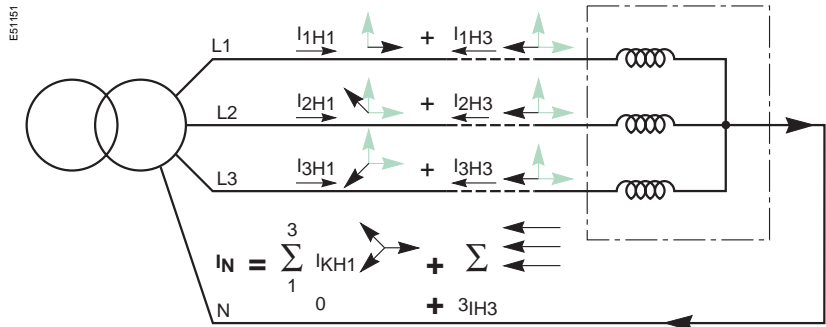

Diagram 20 - third harmonics flow

Indeed, given their frequency that is three times higher and their current shift in modules of $2\pi/3$, only third harmonic and multiples of three currents are added to the Neutral instead of being cancelled. The other orders can be ignored.

Facing this problem, several solutions are possible:

- oversizing the Neutral cable
- balancing the loads as much as possible
- connecting a coupled transformer Y_D that blocks third order harmonics currents.

The **NEC philosophy**, which does not foresee protection of the Neutral, recommends oversizing the Neutral cable by doubling it.

(1) A study conducted in 1990 concerning the power supply of computer type loads shows that:

- for a great number of sites, the Neutral current is in the realm of 25 % of the medium current per Phase
- 23 % of the sites have a Neutral current of over 100 % of the current per Phase.

3.2.2. Incidences on GFP Measurement

In a TN-S system, there are no incidences. But caution must be taken so that the TN-S system does not transform into a TN-C system.

In a TN-C system, the Neutral conductor and the PE are the same. The Neutral currents (especially harmonics) flow in the PE and in the structures.

The currents in the PE can create disturbances in sensitive switchgear:

- by radiation of structures
- by loss of equipotentiality between 2 switchgears.

A TN-S system that transforms into a TN-C system causes the same problems.

Currents measured by GFP devices on the supply end become erroneous:

- natural Neutral currents can be interpreted as fault currents
- fault currents that flow through the Neutral conductor can be desensitized or can cause nuisance tripping of GFP devices.

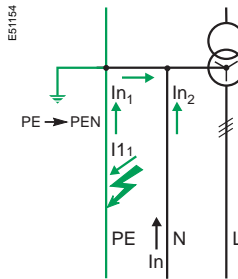

Diagram 21a - TN-S transformed into TN-C

Examples

case 1: insulation fault on the Neutral conductor

The TN-S system transforms into a TN-C system upon an insulation fault of the Neutral conductor. This fault is not dangerous and so the installation does not need to be deenergised.

On the other hand, current flow that is upstream from the fault can cause dysfunctioning of GFP device.

The installation therefore needs to be verified to make sure that this type of fault does not exist.

case 2: multisource with multigrounding

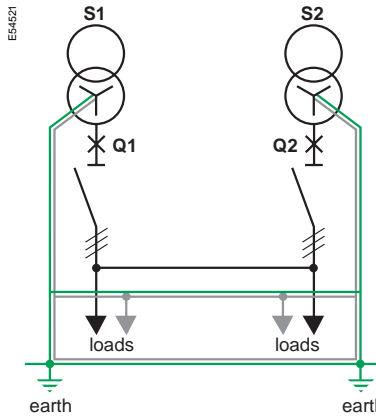

Diagram 21b - multisource / multigrounding system with a PEN conductor

This is a frequent case especially for carrying out an installation extension. As soon as two power supplies are coupled with several Earthings, the Neutral conductors that are upstream from couplings are transformed into PENs.

Note: a single earthing of the 2 power supplies reduces the problem (current flow of the Neutral in structures) but:

- Neutral conductors upstream from couplings are PENs
- this system is not very easy to correctly construct.

Note: the following code will be used to study the diagrams:

- Neutral
- P E
- P E N

Implementation of a system with a single power supply does not present any particular problems because a fault or Neutral current can not be deviated.

3.3. Applications

3.3.1. Methodology

The implementation mentioned in paragraph 3.1 consists in verifying 6 criteria.

■ **measurement**

a 0: the GFP device is physically correctly installed: the measuring CT is correctly positioned.

The next step consists in verifying on the single-line.

■ **TN-S system, i.e.**

□ operating without faults:

a 1: GFP devices do not undergo nuisance tripping with or without unbalanced and/or harmonic loads

a 2: surrounding sensitive switchgear is not disturbed.

□ operating with faults:

b 1: the GFP device on the fault outgoer measures the “true” fault value

b 2: GFP devices not dealt with do not undergo nuisance tripping.

■ **availability**

b 3: discrimination with upstream and downstream protection devices is ensured upon an insulation fault.

3.3.2. Application: Implementation in a Single-source TN-S system

It does not present any problems if the above methodology is respected.

■ **measurement**

a 0 criterion

It is necessary to verify that:

□ in a “Residual Sensing” system, all of the live cables are monitored and that the toroid on the Neutral conductor is correctly positioned (primary current direction, cabling of the secondary)

□ in a “Source Ground Return” system, the measurement toroid is correctly installed on the PE (and not on a PEN or Neutral conductor).

■ **TN-S system**

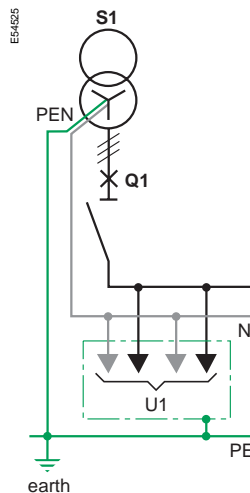

Diagram 22 - single-source

a 1 and a 2 criteria

□ current flowing through the Neutral can only return to the power supply on one path, if harmonic currents are or are not in the Neutral. The vectorial sum of currents (3 Ph + N) is nul.

Criterion a 1 is verified.

□ the Neutral current cannot return in the PE because there is only one connection of the Neutral from the transformer to the PE. Radiation of structures is not possible.

Criterion a 2 is verified.

b 1 and b 2 criteria

Upon fault, the current cannot return via the Neutral and returns entirely into the power supply via the PE. Due to this:

□ GFP devices located on the feeder supply system read the true fault current

□ the others that cannot see it remain inactive.

Criteria b 1 and b 2 are verified.

b 3 criterion

■ **availability**

□ discrimination must be ensured according to the rules in paragraph 2.2.

Criterion b 3 is then verified.

As soon as the network has at least 2 power supplies, the protection system decided upon must take into account problems linked to:

- third order harmonics and multiples of 3
 - the non-breaking of the Neutral
 - possible current deviations.
- Consequently, the study of a "multisource" diagram must clearly show the possible return paths:
- of the Neutral currents
 - of the insulation fault currents
- i.e. clearly distinguish the PE and the PEN parts of the diagram.

3.3.3. Application: Implementation in a Multisource TN-S system

The multisource case is more complex.

A multiple number of network configurations is possible depending on:

- the system (parallel power sources, Normal / Replacement power source, etc.)
- power source management
- the number of Neutral Earthings on the installation: the NEC generally recommends a single Earthing, but tolerates this type of system in certain cases (§ 250-21 (b))
- the solution decided upon to carry out the Earthing.

Each of these configurations requires a special case study.

The applications presented in this paragraph are of the multisource type with 2 power sources.

The different schematic diagrams are condensed in this table.

	Switchgear Position		
Operation	Q1	Q2	Q3
Normal N	C	C	O
Replacement R1	O	C	C
Replacement R2	C	O	C

C: Closed O: Open

The 6 criteria (a 0, a 1, a 2, b 1, b 2 and b 3) to be applied to each system are defined in paragraph 3-2-1.

To study all case figures and taking into account the symmetry between GFP1 and GFP2 devices, 12 criteria must be verified (6 criteria x 2 systems).

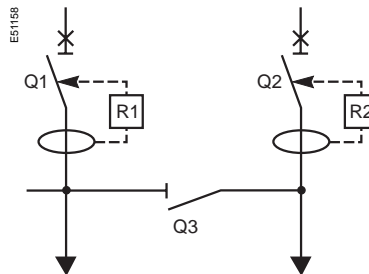

Diagram 24 - coupling

Study of Multisource Systems

4.1. A Multisource System with a Single Earthing

The Multisource / one Grounding diagram is characterised by a PEN on the incoming link(s):

- the diagram normally used is diagram 2 (Grounding is symmetrical and performed at coupling level)
- diagrams 1 and 3 are only used in source coupling.

Characteristics of diagram 2

Ground Fault Protection may be:

- of the SGR type
- of the RS type if uncoupling of the load Neutral is performed properly
- the incoming circuit-breakers are of the three-pole type.

Fault management does not require Ground Fault Protection on the coupler.

Characteristics of diagrams 1 and 3

These diagrams are not symmetrical. They are advantageous only when used in source coupling with a GE as a Replacement source.

These systems are not easily constructed nor maintained in the case of extension: second earthings should be avoided. Only one return path to the source exists:

- for natural Neutral currents
- for PE fault currents.

There are 3 types of diagram (figure 25):

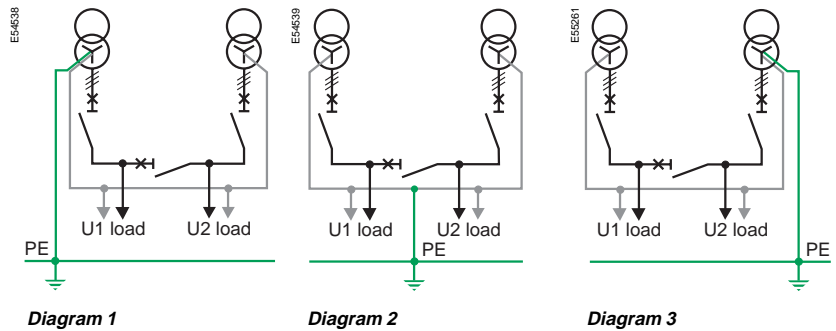

Diagram 1

Diagram 2

Diagram 3

Diagram 25

Diagram 2 is the only one used in its present state.

Diagrams 1 and 3 are only used in their simplified form:

- load U2 (diagram 1) or U1 (diagram 3) absent
- no Q3 coupling

The study of these diagrams is characterised by a PEN on the incoming link(s). Consequently, the incoming circuit-breakers Q1 and Q2 must be of the three-pole type.

4.1.1. Diagram 2

Once Earthing of the Neutral has been carried out using a distribution Neutral Conductor, the Neutral on supply end protection devices is thus considered to be a PEN. However, the Earthing link is a PE.

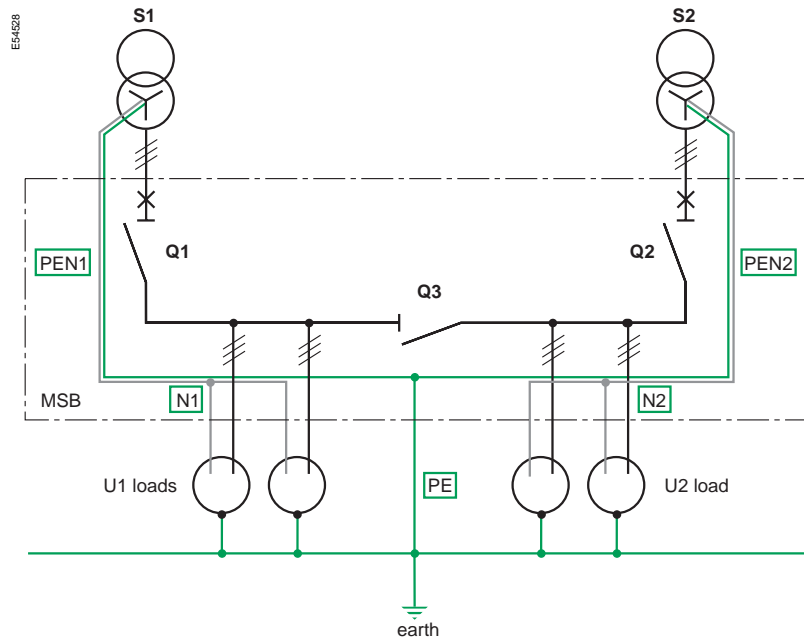

Diagram 26a

Reminder of the coding system used:

- Neutral
- P E
- P E N

4.1.1.1. Study 1 / diagram 2

The supply end Earth protection device can be implemented using GFP devices of the Source Ground Return type of which the measuring CTs are installed on this link (see diagram 26b).

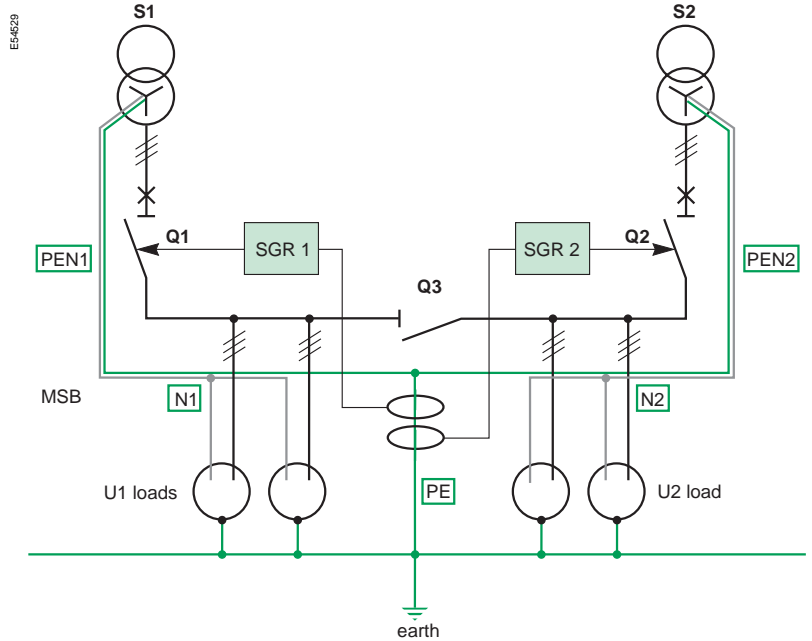

Diagram 26b - "Source Ground Return" type system

In normal N operation:

- a 0 is verified because it deals with a PE
- a 1, a 2 are verified as well (currents in the Neutral conductor cannot flow in the PE and the Earth circuits)
- b 1 is verified
- b 2 is not verified because it deals with a PE common to 2 parts of the installation
- b 3 can be verified without any problems.

Implemented GFP devices ensure installation safety because maximum leakage current for both installations is always limited to 1200 A.

But supply is interrupted because an insulation fault leads to deenergisation of the entire installation.

For example, a fault on U2 leads to the deenergisation of U1 and U2.

In R1 or R2 replacement operation:

All operation criteria are verified.

To completely resolve the problem linked to b 2 criterion, one can:

- implement a CT coupling system (Study 2)
- upgrade the installation system (Study 3).

4.1.1.2. Study 2 / diagram 2

Seeing that A1 (or A2) is:

- a PE in normal N operation
- a PEN in R1 (or R2) operation
- a Neutre in R2 (or R1) operation,

measuring CTs on the supply end GFP devices (of the SGR type) can be installed on these links.

In normal N operation (see diagram 27a)

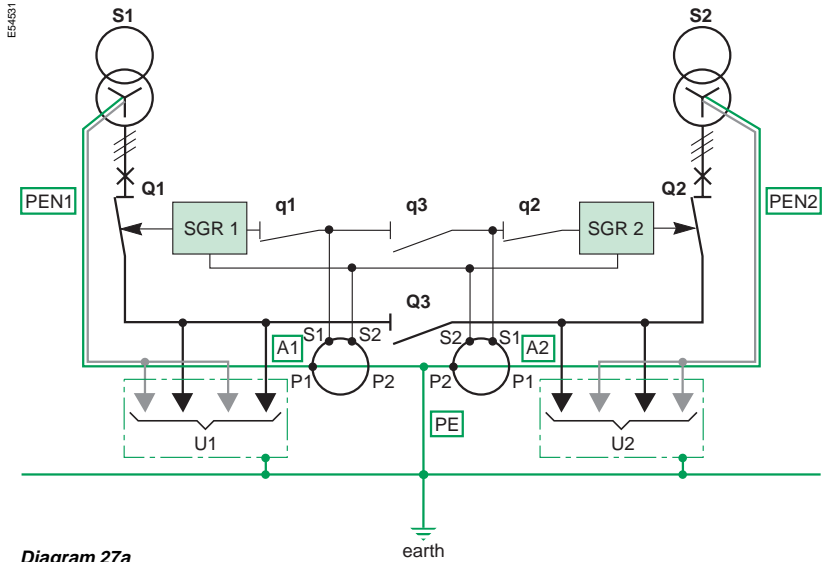

Diagram 27a

Operation criteria are verified because A1 (or A2) is a PE.

In R1 replacement operation (see diagram 27b)

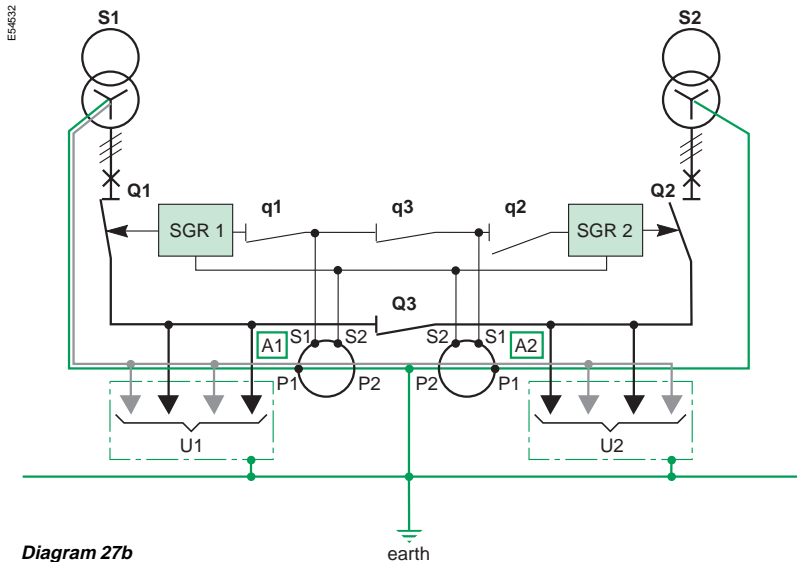

Diagram 27b

Since link A1 is a PEN for loads U1 and U2 and link A2 is a Neutral for load U2, the Neutral current measurement can be eliminated in this conductor by coupling the CTs (see figure 27b).

Fault currents are only measured by the Q1 measurement CT: no discrimination is possible between U1 and U2.

For this reason, all operation criteria are verified.

Note: measuring CTs must be **correctly polarised** and have the **same rating**.

In R2 replacement operation: same principle.

4.1.1.3. Study 3 / diagram 3

In this configuration, used in Australia, the Neutral on supply end devices is "remanufactured" downstream from the PE. It is however necessary to ensure that no other upstream Neutrals and/or downstream PEs are connected. This would falsify measurements.

Protection is ensured using GFP devices of the Residual type that have the Neutral CT located on this link (of course, polarity must be respected).

In N normal operation (see diagram 28a)

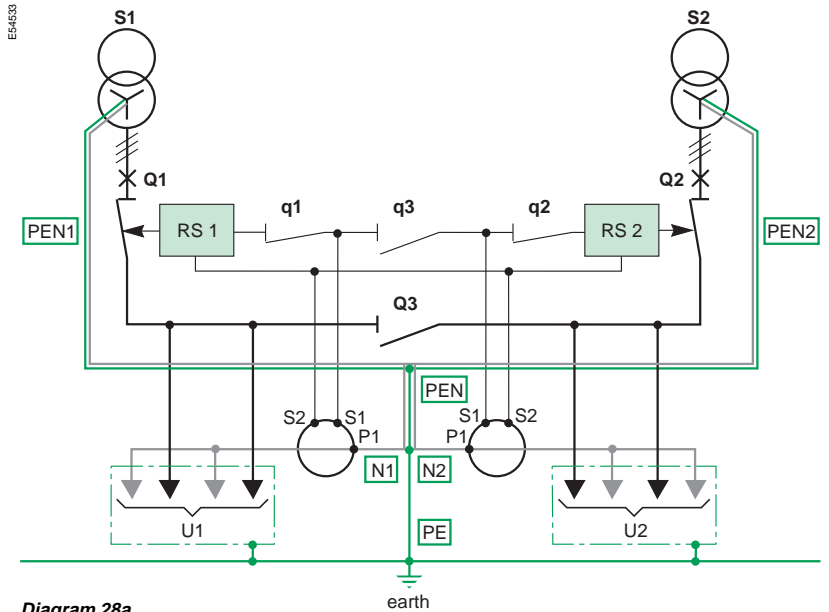

Diagram 28a

a1 and a2 criteria

The current that flows through the N1 (or N2) Neutral has only one path to return to the power source. The GFP1 (or GFP2) device calculates the vectorial sum of all Phases and Neutral currents. a1 and a2 criteria are verified.

b1 and b2 criteria

Upon fault on U1 (or U2), the current cannot return via the N1 (or N2) Neutral. It returns entirely to the power source via the PE and the PEN1 (or PEN2). For this reason, the GFP1 (or GFP2) device located on the feeder supply system reads the true fault current and the GFP2 (or GFP1) device does not see any fault current and remains inactive.

b3 criterion

Discrimination must be ensured according to the conditions defined in paragraph 2-2. Therefore, all criteria is verified.

In R1 (or R2) replacement operation (see diagram 28b)

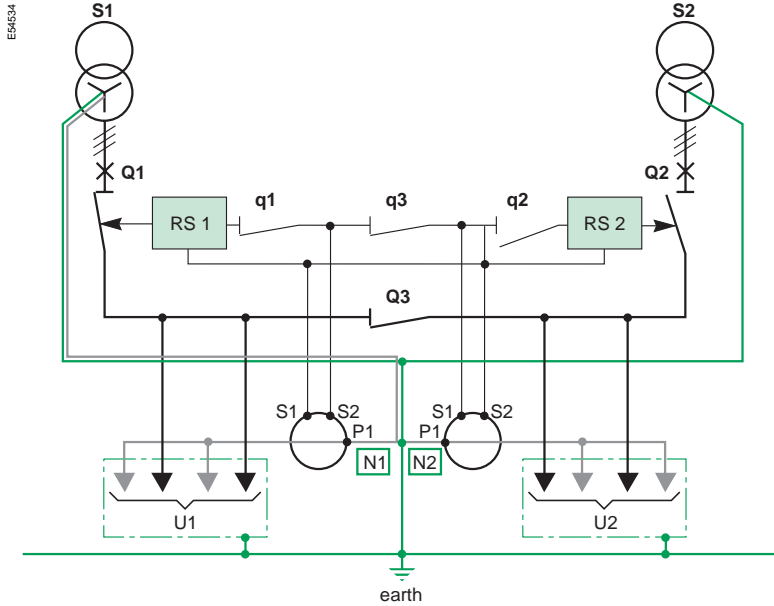

Diagram 28b

The N1 (or N2) functions are not affected by this operation and so as to manage protection of the 2 uses (U1 + U2), the sum of Neutral currents (N1+N2) must be calculated.

CT coupling carried out in diagram 28b allows for these two criteria to be verified.

In R2 replacement operation: same principle.

4.1.1.4. Comments

The diagram with symmetrical Grounding is used in Anglo-Saxon countries. It calls for strict compliance with the layout of the PE, Neutral and PEN in the main LV switchboard.

Additional characteristics

- management of fault currents without measuring CTs on the coupler
- complete testing of the GFP function possible in the factory: external CTs are located in the main LV switchboard
- protection only provided on the part of the installation downstream of the measuring CTs: a problem if the sources are at a distance.

4.1.2. Diagrams 1 and 3

Diagrams 1 and 3 (see figure 25) are identical.

Note: circuit-breakers Q1 and Q2 must be three-pole.

4.1.2.1. Study of the simplified diagram 1

The operating chart only has 2 states (Normal N or Replacement R2). The diagram and the chart below (see figure 29) represent this type of application: source 2 is often produced by GE.

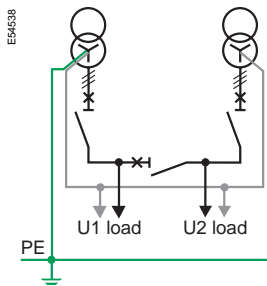

- without load U2
- without coupler Q3.

	Switchgear position	
Operation	Q1	Q2
Normal N	C	O
Replacement R2	O	C

C: Closed
O: Open

Diagram 29

ESB633

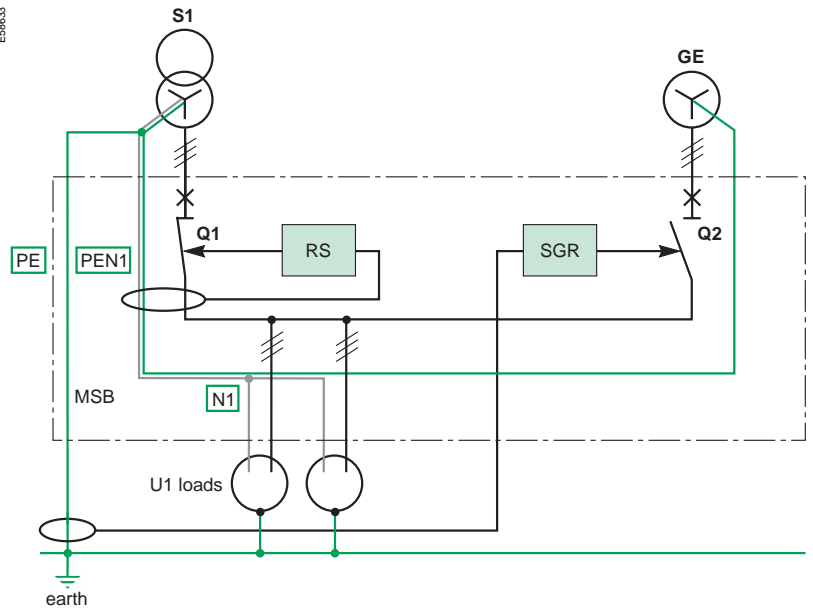

Diagram 30a

In Normal N operation

The diagram is the same as the Single source diagram (PE and Neutral separate). There is thus no problem in implementing Ground Fault Protection GFP1 of the RS or SGR type.

In R2 replacement operation

At Q2, the Neutral and the PE are common (PEN). Consequently, use of a Ground Fault Protection GFP2 of the SGR type with external CT on the PE is the only (simple) solution to be used.

4.1.2.2. Study of the complete diagram

This diagram offers few advantages and, moreover, requires an external CT to ensure proper management of the Ground Fault Protections.

ESB634

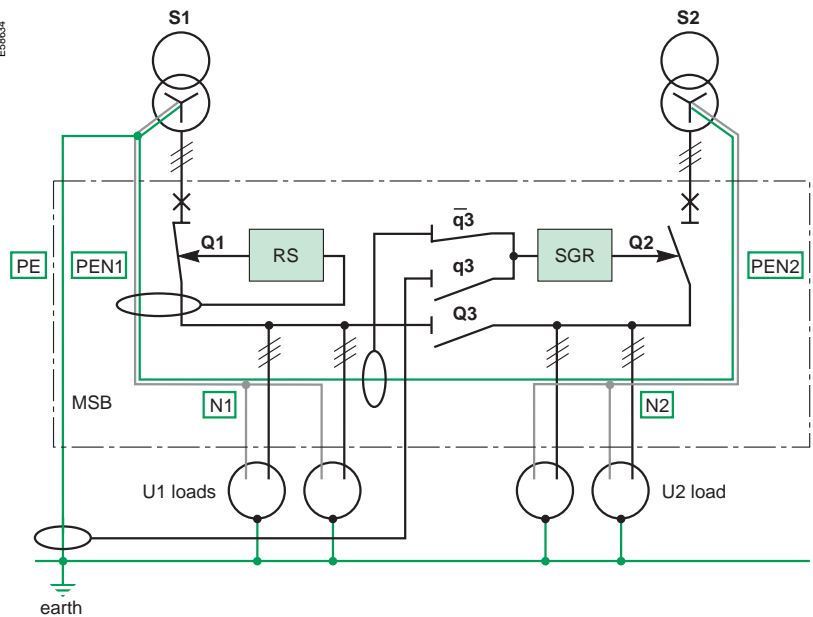

Diagram 30b

In Normal N operation

For Q1, the diagram is the same as that of a Single source diagram.

For Q2, GFP2 is of the SGR type with the measurement taken on PE2 (see fig. 30b).

In Normal R1 operation

The diagram is similar to a Single source diagram.

In Normal R2 operation

PE2 becomes a PEN. A 2nd external CT on the PE (see figure 30b) associated with relays takes the measurement.

The Multisource diagram with several earthings is easy to implement. However, at Ground Fault Protection (GFP) level, special relays must be used if the Neutral conductor is not broken. Use of four-pole incoming and coupling circuit-breakers eliminates such problems and ensures easy and effective management of Ground Fault Protection (GFP).

4.2. A Multisource System with Several Earthings

The Neutral points on the LV transformers of S1 and S2 power sources are directly Earthed. This Earthing can be common to both or separate. A current in the U1 load Neutral conductor can flow back directly to S1 or flow through the earthings.

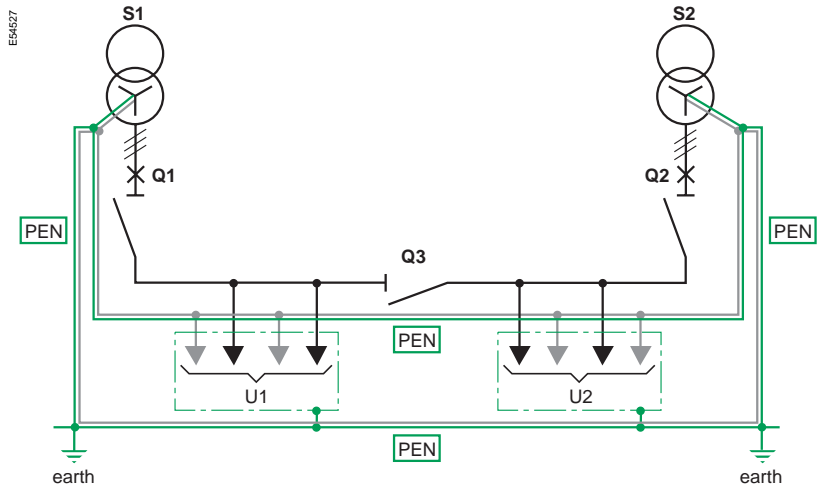

Diagram 31 - "multisource system with 2 Earthings"

4.2.1. System Study

■ by applying the implementation methodology to Normal operation.

a1 criterion: balanced loads without harmonics in U1 and U2

For U1 loads, the current in the Neutral is weak or non-existent. Currents in paths A and B are also weak or non-existent. The supply end GFP devices (GFP1 and GFP2) do not measure any currents. Operation functions correctly. Id, if one looks at U2 loads.

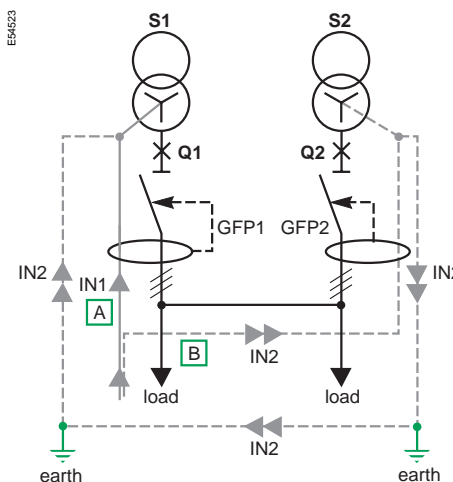

Diagram 32a - "a2 criterion": current flow in structures

a2 criterion with harmonics on U1 loads

Current flowing in the Neutral is strong and thus currents in paths A and B are strong as well. Supply end GFP devices (GFP1 and GFP2) measure a current that, depending on threshold levels, can cause nuisance tripping. Operation does not function correctly. Currents following path B flow in the structures. a2 criterion is not verified.

In event of a fault on the loads 1, the I_f current can flow back via the Neutral conductor (not broken) if it is shared in I_{f1} and I_{f2} .

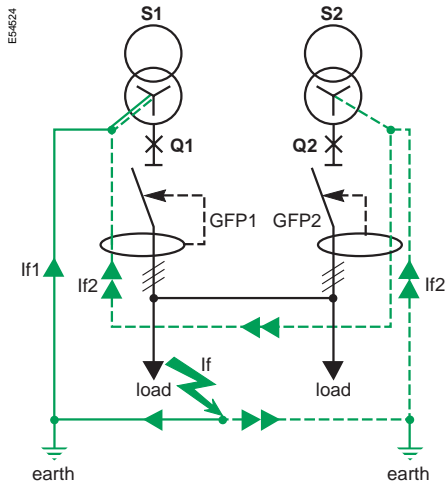

Diagram 32b - "b1 and b2 criteria"

b1 criterion

For the GFP1 device, the measured I_{f1} current is less than the true fault current. This can lead to the non-operation of GFP1 upon dangerous fault. Operation does not function correctly. b1 criterion is not verified.

b2 criterion

For the GFP2 device, an I_{f2} current is measured by the supply end GFP device, even though there is no fault. This can lead to nuisance tripping of the GFP1 device. Operation does not function correctly.

b3 criterion

A discrimination study is not applicable as long as the encountered dysfunctions have not been resolved.

■ in R1 (or R2) operation.

The dysfunctions encountered during Normal operation subsist.

The implementation of GFP devices on multisource systems, with several Earthings and with a connected Neutral, require a more precise study to be carried out. Furthermore, the Neutral current, which flows in the PE via path B, can flow in the metal parts of switchgear that is connected to the Earth and can lead to dysfunctioning of sensitive switchgear.

4.2.2. Solutions

4.2.2.1. Modified Differential GFP

Three GFP devices of the Residual Sensing type are installed on protection devices and coupling (cf. diagram 33a). By using Kirchoff's laws and thanks to intelligent coupling of the CTs, the incidence of the natural current in the Neutral (perceived as a circulating current) can be eliminated and only the fault current calculated.

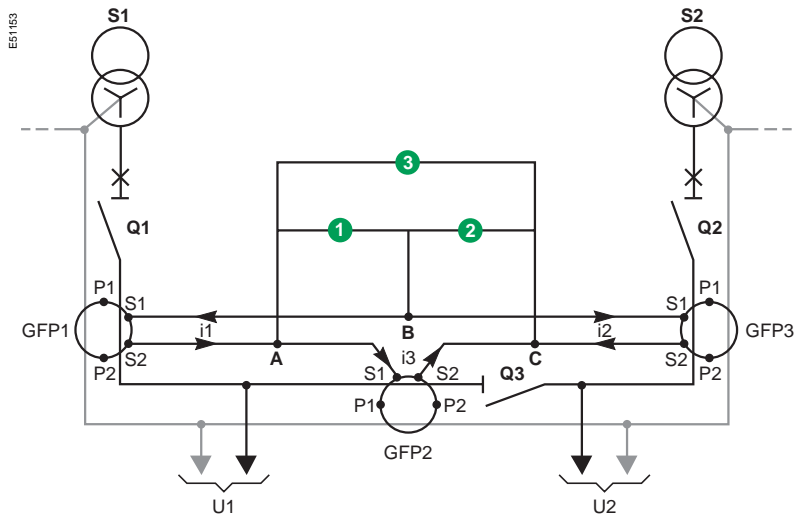

Figure 33a - "logique d'interverrouillage et reconstitution de la mesure"

Study 1: Management of Neutral currents

To simplify the reasoning process, this study is conducted on the basis of the following diagram:

- Normal operation N
- load U1 generating Neutral currents (harmonic and/or unbalance), i.e. phase $I_{U1} = \hat{a} \uparrow \text{ph}$, neutral $I_{U1} = I_N$
- no load U2, i.e. phase $I_{U2} = 0$, neutral $I_{U2} = 0$
- no faults on U1/U2, i.e. $\hat{a} \uparrow \text{ph} + \uparrow N = 0$.

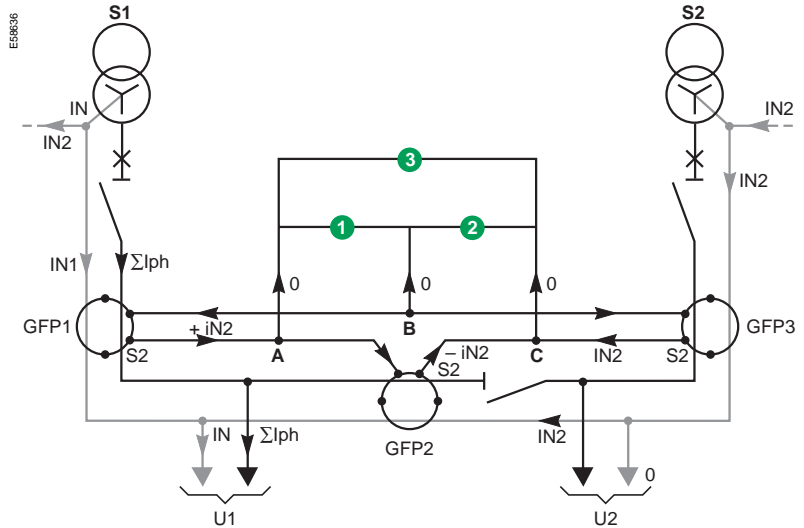

Diagram 33b - U1 Neutral current

■ From the remarks formulated above (see paragraph 4.2.1.), the following can be deduced:

- $\uparrow N = \uparrow N1 + \uparrow N2$
 - primary current in GFP1: $\uparrow 1 = \uparrow N1 + s \uparrow \text{ph} = -\uparrow N2$
 - secondary current of GFP1: $i1 = -iN2$
- Likewise, the measurement currents of GFP2 and GFP3:
- secondary current of GFP2: $i2 = iN2$
 - secondary current of GFP3: $i3 = -iN2$

■ With respect to secondary measurements, iA , iB and iC allow management of the following GFPs:

- $iA = i1 - i3 \text{ @ } iA = 0$
- $iB = i1 - i2 \text{ @ } iB = 0$
- $iC = i2 + i3 \text{ @ } iC = 0$

■ Conclusion: no (false) detection of faults: criterion a1 is properly verified.

Study 2: Management of fault currents

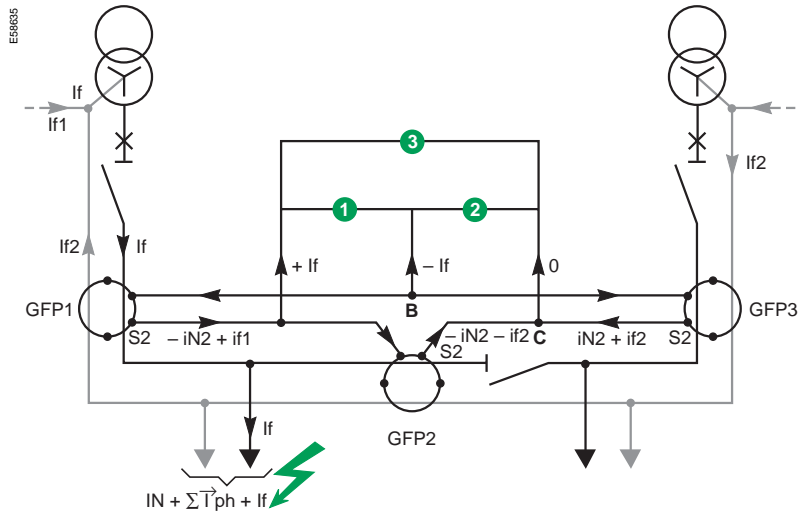

- ⊙ activated.
- activated.
- gives the fault value.

Diagram 33c - simplified fault on U1: no Neutral current ($s^1 \text{ph} = 0, I_N = 0$)

Same operating principle as for study 1, but:

- Normal operation N
- load U1 generating Neutral currents (harmonic and/or unbalance), i.e. phase IU1 = $\hat{a} \hat{I}_{ph}$, neutral IU1 = IN
- no load U2, i.e. phase IU2 = 0, neutral IU2 = 0
- faults on U1 ($\hat{I} f$), i.e. $\hat{a} \hat{I}_{ph} + \hat{I} N + \hat{I} f = \emptyset$.

■ Using study 1 and the remarks formulated above (see paragraph 4.2.1.), the following can be deduced:

- $\hat{I} f = \hat{I} f1 + \hat{I} f2$
 - primary current in GFP1: $\hat{I} 1 = \hat{I} N2 + \hat{I} - \hat{I} f2 = -\hat{I} N2 + \hat{I} f1$
 - secondary current of GFP1: $i1 = -iN2 + if1$.
- Likewise, the measurement currents of GFP2 and GFP3:
- secondary current of GFP2: $i2 = iN2 + if2$
 - secondary current of GFP3: $i3 = -iN2 - if2$.
 - i.e. at iA, iB and iC level: $iA = if$, $iB = -if$ and $ic = \emptyset$.

■ Conclusion: **exact** detection and measurement of the fault on study 1: no indication on study 2. Criteria b 1 and b 2 are verified.

Remarks: Both studies show us that it is extremely important to respect the primary and secondary positioning of the measurement toroids.

Extensively used in the USA, this technique offers many advantages:

- it only implements standard RS GFPs
- it can be used for complex systems with more than 2 sources: in this case coupling must also be standardised
- it can be used to determine the part of the diagram that is faulty when the coupling circuit-breaker is closed.

On the other hand, it does not eliminate the Neutral circulating currents in the structures. It can only be used if the risk of harmonic currents in the neutral is small.

4.2.2.2. Neutral Breaking

In fact, the encountered problem is mainly due to the fact that there are 2 possible paths for fault current return and/or Neutral current.

In Normal Operation

Coupling using a 4P switchgear allows the Neutral path to be broken. The multisource system with several Earthings is then equivalent to 2 single-source systems. This technique perfectly satisfies implementation criteria, including the a 2 criterion, because the TN-S system is completely conserved.

In R1 and R2 Operation

If this system is to be used in all case figures, three 4P devices must be used.

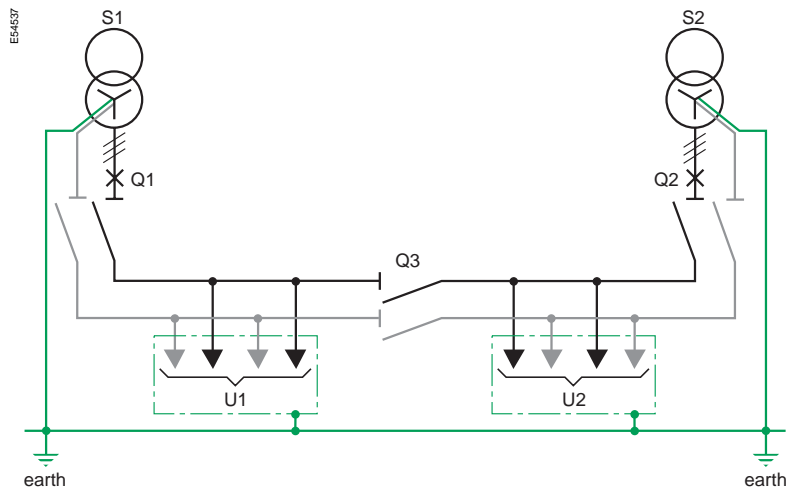

Diagram 34

This technique is used to correctly and simply manage Multisource diagrams with several Earthings, i.e.:

- GFP1 and GFP2, RS or SGR standards
- GFP3 (on coupling), RS standard not necessary, but enables management in R1 (or R2) operation of the fault on load U1 or U2.

Moreover, there are no more Neutral currents flowing in the structures.

Protection using GFP devices is vital for reducing the risk of fire on a LV installation using a TN-S system when Phases / PE fault impedance is not controlled.

To avoid dysfunctioning and/or losses in the continuity of supply, special attention is required for their implementation.

The Single-source diagram presents no problems.

The Multisource diagram must be carefully studied.

The Multisource diagram with multiple earthings and four-pole breaking at coupling and incomer level, simplifies the study and eliminates the malfunctions.

Conclusion

5.1 Implementation

The methodology, especially § 331 p. 22, must be followed:

- measurement:
 - physical mounting of CTs and connection of CT secondaries according to the rules of the trade
 - do not forget the current measurement in the Neutral conductor.
- Earthing System:
 - The system must be of the TN-S type.
- availability:
 - Discrimination between upstream GFP devices must be ensured with:
 - downstream GFP devices
 - downstream short delay circuit-breakers.

5.2 Wiring Diagram Study

Two case figures should be taken into consideration:

- downstream GFP in sub-distribution (downstream of eventual source couplings):
 - no system problem.
 - The GFP device is of the Residual Sensing (RS) type combined with a 3P or 4P circuit-breaker.
- upstream GFP at the incomer general protection level and/or at the coupling level, if it is installed: the system is to be studied in more detail.

5.2.1. Single-source System

This system does not present any particular problems if the implementation methodology is respected.

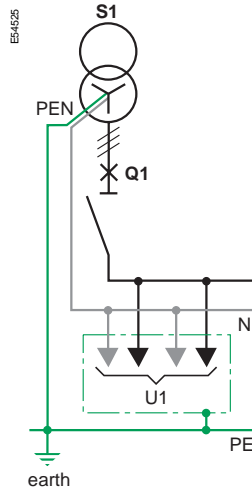

Diagram 22 - single-source system

5.2.2. Multisource / Single-ground System

This type of system is not easy to implement: it must be rigorously constructed especially in the case of extension (adding an additional source). It prevents the “return” of Neutral current into the PE.

Source and Coupling circuit-breakers must be 3P.

5.2.2.1. Normal Operation

To be operational vis-à-vis GFP devices, this system must have:

- either, a Neutral conductor for all the users that are supplied by each source: measurement is of the RS type.
- or, a PE conductor for all of the users that are supplied by each source: measurement is of the SGR type.

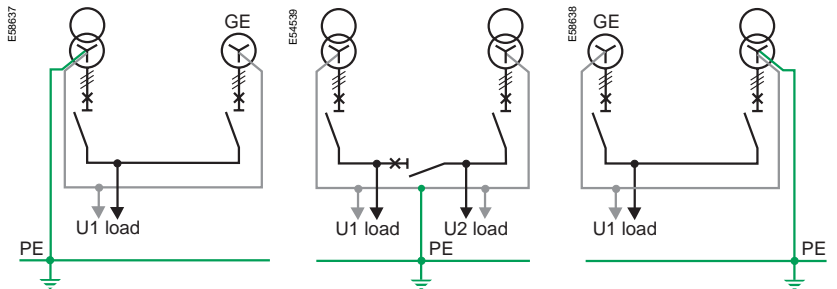

System 1
Only useful in source coupling (no Q3 coupling) = case of the GE

System 2
Accessible Neutral Conductors and PE for each source. The GFP1 (GFP2) device is:
■ of the RS type with an external CT on the Neutral conductor N1 (N2)
■ of the SGR type with an external CT on the PE conductor PE1 (PE2)

System 3
Only useful in source coupling (no Q3 coupling) = case of the GE

5.2.2.2. Replacement Operation

In replacement operation, the correct paralleling of external CTs allows for insulation fault management.

5.2.3. Multisource / Multiground System

This system is frequently used. Circulating current flow can be generated in PE circuits and insulation fault current management proves to be delicate. Efficiently managing this type of system is possible but difficult.

4P breaking at the incomer circuit-breaker level and coupling allow for simple and efficient management of these 2 problems.

This system thus becomes the equivalent of several single-source systems.

5.3 Summary Table

5.3.1. Depending on the Installation System

The table below indicates the possible GFP choices depending on the system.

Type of GFP	Installation Supply End						Sub-distribution All Systems					
	Single-source			Multisource / Single-ground			Multisource / Multiground			All Systems		
	GFP	combined 3P	CB 4P	GFP	combined 3P	CB 4P	GFP	combined 3P	CB 4P	GFP	combined 3P	CB 4P
Source Ground Return SGR	<input type="checkbox"/>	<input type="checkbox"/>	<input checked="" type="checkbox"/>	<input type="checkbox"/> (2)	<input checked="" type="checkbox"/>	<input type="checkbox"/>	<input type="checkbox"/>	<input type="checkbox"/>	<input checked="" type="checkbox"/> (4)	<input type="checkbox"/>	<input type="checkbox"/>	<input type="checkbox"/>
Residual Sensing RS	<input type="checkbox"/>	<input type="checkbox"/>	<input checked="" type="checkbox"/> (1)	<input type="checkbox"/> (2)	<input checked="" type="checkbox"/>	<input type="checkbox"/>	<input checked="" type="checkbox"/> (3)	<input type="checkbox"/>	<input checked="" type="checkbox"/> (4)	<input checked="" type="checkbox"/>	<input type="checkbox"/>	<input checked="" type="checkbox"/>
Zero Sequence (5) ZS	<input type="checkbox"/>	<input type="checkbox"/>	<input type="checkbox"/>	<input type="checkbox"/>	<input checked="" type="checkbox"/>	<input type="checkbox"/>	<input type="checkbox"/>	<input type="checkbox"/>	<input checked="" type="checkbox"/> (4)	<input type="checkbox"/>	<input type="checkbox"/>	<input type="checkbox"/>

(1) allows for an extension (2nd source) without any problems.

(2) if a Neutral for each source is available, the RS type can be used if a PE for each source is available, the SGR type can be used, in all cases, an SGR type can be used on the general PE (but with discrimination loss between sources).

(3) allows for protection standardisation.

(4) 3P is possible but the system is more complicated and there is Neutral current flow in the PE.

(5) used for weak current values (200 A).

Key:

- required or highly recommended,
- possible,
- forbidden or strongly disrecommended.

5.3.2. Advantages and Disadvantages depending on the Type of GFP

Different analyses, a comparative of different GFP types.

	Advantages	Disadvantages
Residual Sensing with 4P circuit-breaker (CT on built in Neutral)	CT of each Phase and Neutral built-into the circuit-breaker (standard product) Manufacturer Guarantee Assembled by the panel builder (can be factory tested) Safe thanks to its own current supply Can be installed on incomers or outgoers	Tolerance in measurements (only Low Sensitivity > 100 A)
with 3P circuit-breaker (CT on external Neutral)	Assembled by the panel builder (can be factory tested) Can be applied to different systems: a Neutral conductor can be used "separately" from the circuit-breaker Safe thanks to its own current supply Can be installed on incomers or outgoers	Tolerance in measurements (only LS > 100 A) Neutral current measurement cannot be forgotten The CT is not built into the circuit-breaker = good positioning of the Neutral's CT (direction)
Source ground return	Can be applied to different systems: a PE conductor can be used "separately" from the circuit-breaker Safe thanks to its own current supply Can be added after installation	The CT is not built into the circuit-breaker Requires access to the transformer (factory testing not possible) Cannot be installed on sub-distributed outgoers
Zero sequence	Can detect weak current values (< 50 A) Uses autonomous relays	Requires an auxiliary source Difficult installation on large cross-section conductors Toroid saturation problem (solutions limited to 300 A)

Installation and implementation of GFP solutions

Ground Fault Protection with Masterpact NT/NW	p 38
Ground Fault Protection with Compact NS630b/1600 and NS1600b/3200	p 40
Ground Fault Protection with RH relays and toroids of the A, OA and E types	p 44
Implementation in the installation	p 46
Study of discrimination between GFP	p 48
Study of ZSI discrimination	p 50

E55489



Ground Fault Protection with Masterpact NT/NW

Technical data and Settings

Trip units

Micrologic 6.0 A/P/H

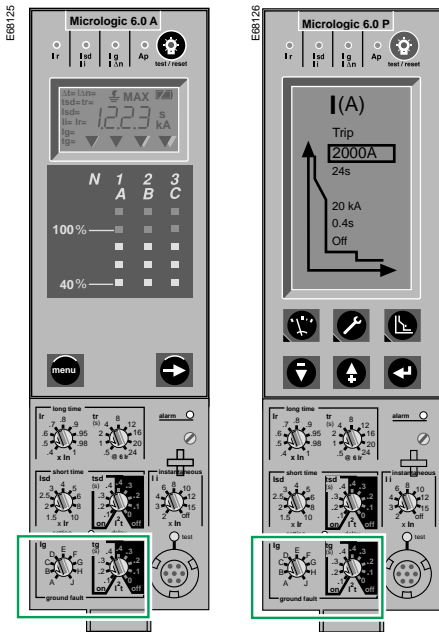

Micrologic 6.0 A

Micrologic 6.0 P/H

Micrologic 6.0 A/P/H Setting by switch

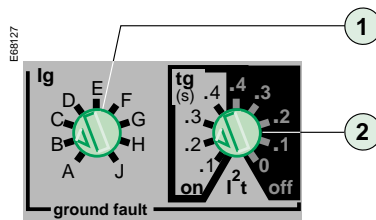

- 1 tripping threshold on a Ground fault.
- 2 time delay on a Ground fault and I²t on/off.

Micrologic 6.0 P/H Setting by keyboard

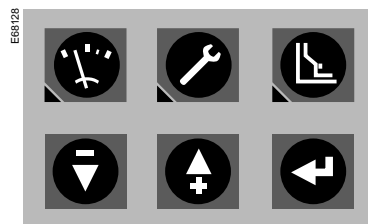

- 3 selection key of parameter I_g.
- 4 parameter setting and memorisation keys (including I_g).

The Micrologic 6.0 A/P/H trip units are optionally equipped with Ground Fault Protection. A ZSI terminal block allows several control units to be linked to obtain GFP total discrimination without time delay tripping

Catalog Numbers	
Micrologic 6.0A	33073
Micrologic 6.0P	47059
Micrologic 6.0H	47062

Functions	Micrologic 6.0A/P/H
"Ground Fault" Protection of the "residual" type or the "source ground return" type	■
Threshold setting	A B C D E F G H J
by switch	In ≤ 400 A I _g = In x ... 0,3 0,3 0,4 0,5 0,6 0,7 0,8 0,9 1
accuracy : ±10 %	400 A < In ≤ 1200 A I _g = In x ... 0,2 0,3 0,4 0,5 0,6 0,7 0,8 0,9 1
	In > 1200 A I _g = ... 500 640 720 800 880 960 1040 1120 1200
Time delay (th)	
settings	with I ² t ON 0 0,1 0,2 0,3 0,4
	with I ² t OFF 0,1 0,2 0,3 0,4
maximum overcurrent time without tripping (ms)	20 80 140 230 350
maximum breaking time (ms)	80 140 230 350 500
Indication of fault type (F) including Ground fault by LED on the front panel	■
Fault indication contact including Ground fault output by dry contact	■
Logic discrimination (Z)	
by opto-electronic contact	■
External supply by AD module (1)	■

(1) This module is necessary to supply the indication (but not necessary to supply the protection).

Note :

- With micrologic 6.0 P and H, each threshold over may be linked either to a tripping (protection) or to an indication, made by a programmable contact M2C or optional M6C (alarm). The both actions, alarm and protection, are also available.
- The ZSI cabling, identical for Masterpact NT/NW, Compact NS630b/1600 and Compact NS1600b/3200 is in details page 42
- The external supply module AD and battery module BAT, identical for Masterpact NT/NW, Compact NS630b/1600 and Compact NS1600b/3200, are in details page 42.

External Transformer (CT) for residual GF Protection

It is used with 3P circuit breakers and is installed on the neutral conductor to achieve a GFP protection of Residual type.

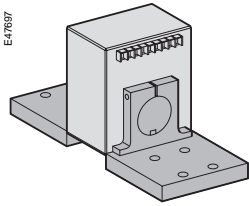

Cabling Précautions:

- Shielded cable with 2 twisted pairs
- Shielding connected to GND on one end only
- Maximum length 5 meters
- Cable cross-sectional area to 0.4 to 1.5 mm²
- Recommended cable: Belden 9552 or equivalent.
- The external CT rating may be compatible with the circuit breaker normal rating :
 NT06 à NT16 : CT 400/1600
 NW08 à NW20 : CT 400/2000
 NW25 à NW40 : CT 1000/4000
 NW40b à NW63 : CT 2000/6300

The signal connection Vn is necessary only for power measurement (Micrologic P/H)

If the 2000/6300 current transformer is used: signals SG1 and SG2 must be wired in series, signals X1 and X2 must be wired in parallel.

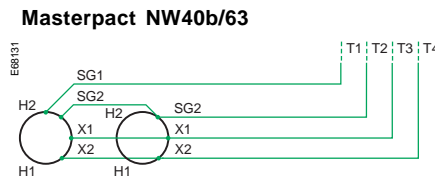
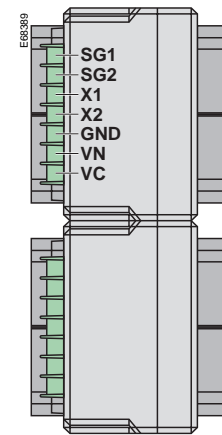
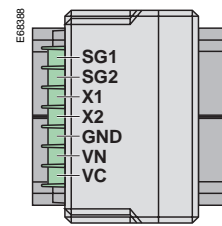
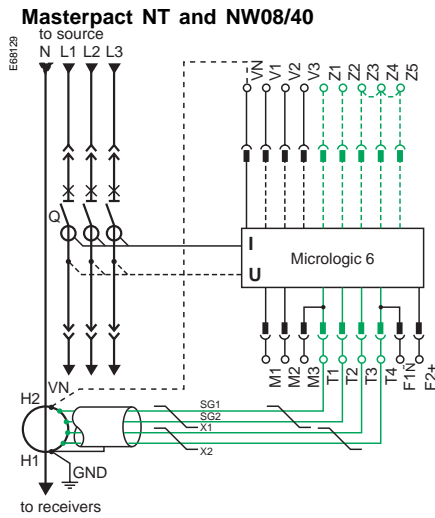

Whatever the Masterpact feeding type, by open or bottom side, the power connection and the terminal connection of external CT are compulsory the same of those phases CT ones.

Feeding by open side H2 is connected to source side and H1 to receiver side.
Feeding by bottom side H1 is connected to source side and H2 to receiver side.

Catalog Numbers ratings (A)	NT	NW
400/2000	33576	34035
1000/4000		34035
2000/6300		48182

External Transformer for Source Ground Return GFP protection

It is installed on the from LV transformer starpoint to the ground link and is connected to Micrologic 6.0 trip unit by "MDGF summer" module to achieve the Ground Fault Protection of SGR type.

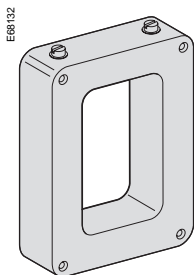

Cabling Protections:

- Unshielded cable with 1 twisted pair
- Shielding connected to GND on one end only
- Maximum length 150 meters

- Cable cross-sectional area to 0.4 to 1.5 mm²
- Recommended cable: Belden 9552 or equivalent.
- Terminals 5 et 6 are exclusives :
 the terminal 5 for Masterpact NW08 à 40
 the terminal 6 for Masterpact NW40b à 63

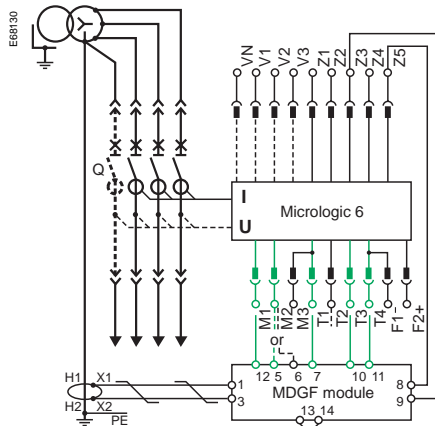

H1 is connected to source side and H2 to receiver side.

Catalog Numbers	
Current Transformer SGR	33579
MDGF module	48891

Ground Fault Protection with Masterpact NS630b/1600 and NS1600b/3200

Technical data and Settings

Trip Units Micrologic 6.0A

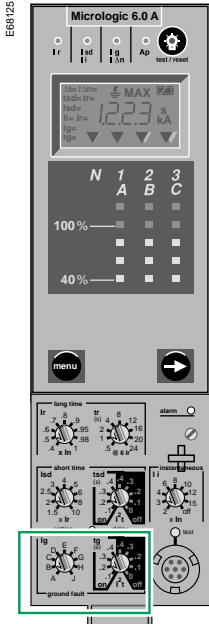

Setting by switch

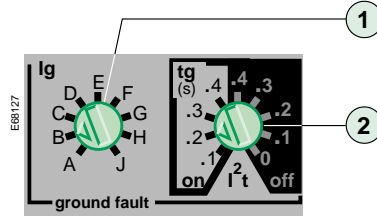

1 tripping threshold on a Ground fault.
2 time delay on a Ground fault and I₂t on/off.

The Micrologic 6.0 A/P/H trip units are optionally equipped with Ground Fault Protection. A ZSI terminal block allows several control units to be linked to obtain GFP total discrimination without time delay tripping

Catalog Numbers

Micrologic 6.0A

33071

Functions		Micrologic 6.0A									
"Ground Fault" Protection of the "residual" type or the "source ground return" type		■									
Threshold setting		A	B	C	D	E	F	G	H	J	
by switch	$I_n \leq 400 \text{ A}$ $I_g = I_n \times \dots$	0,3	0,3	0,4	0,5	0,6	0,7	0,8	0,9	1	
accuracy : ±10 %	$400 \text{ A} < I_n < 1200 \text{ A}$ $I_g = I_n \times \dots$	0,2	0,3	0,4	0,5	0,6	0,7	0,8	0,9	1	
	$I_n \geq 1200 \text{ A}$ $I_g = \dots$	500	640	720	800	880	960	1040	1120	1200	
Time delay (th) settings		0									
	with I ₂ t ON	0,1									
	with I ₂ t OFF	0,2									
	maximum overcurrent time without tripping (ms)	20	80	140	230	350					
	maximum breaking time (ms)	80	140	230	350	500					
Indication of fault type (F) including Ground fault by LED on the front panel		■									
Fault indication contact including Ground fault output by dry contact		■									
Logic discrimination (Z) by Ground T / W opto-electronic contact		■									
External supply by AD module (1)		■									

(1) This module is necessary to supply the indication (but not necessary to supply the protection).

Note :

- With micrologic 6.0 P and H, each threshold over may be linked either to a tripping (protection) or to an indication, made by a programmable contact M2C or optional M6C (alarm). The both actions, alarm and protection, are also available.
- The ZSI cabling, identical for Masterpact NT/NW, Compact NS630b/1600 and Compact NS1600b/3200 is in details page 42
- The external supply module AD and battery module BAT, identical for Masterpact NT/NW, Compact NS630b/1600 and Compact NS1600b/3200, are in details page 42.

External Transformer (CT) for residual GF Protection

It is used with 3P circuit breakers and is installed on the neutral conductor to achieve a GFP protection of Residual type.

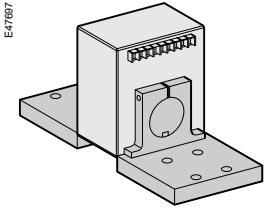

Cabling Précautions:

- Shielded cable with 2 twisted pairs
- Shielding connected to GND on one end only
- Maximum length 5 meters
- Cable cross-sectional area to 0.4 to 1.5 mm²
- Recommended cable: Belden 9552 or equivalent.
- The external CT rating may be compatible with the circuit breaker normal rating:
NS630b to NS1600: TC 400/1600
NS1600b to NS2000: TC 400/2000
NS2500 to NS3200: TC 1000/4000

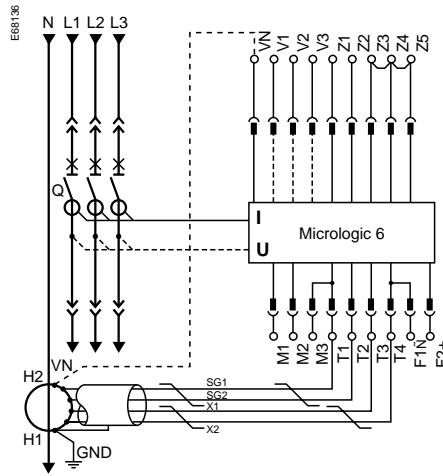

Whatever the Masterpact feeding type, by open or bottom side, the power connection and the terminal connection of external CT are compulsory the same of those phases CT ones.

Feeding by open side H2 is connected to source side and H1 to receiver side.
Feeding by bottom side H1 is connected to source side and H2 to receiver side.

Catalog Numbers ratings (A)	NS
400/2000	33576
1000/3200	34036

External transformer for source ground return (SGR) earth-fault protection

It is installed on the from LV transformer starpoint to the ground link and is connected to Micrologic 6.0 trip unit by "MDGF summer" module to achieve the Ground Fault Protection of SGR type..

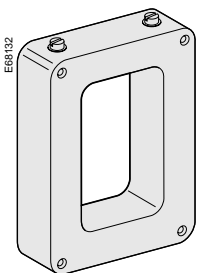

Cabling précautions:

- Unshielded cable with 1 twisted pair
- Shielding connected to GND on one end only
- Maximum length 150 meters
- Cable cross-sectional area to 0.4 to 1.5 mm²
- Recommended cable: Belden 9552 or equivalent.

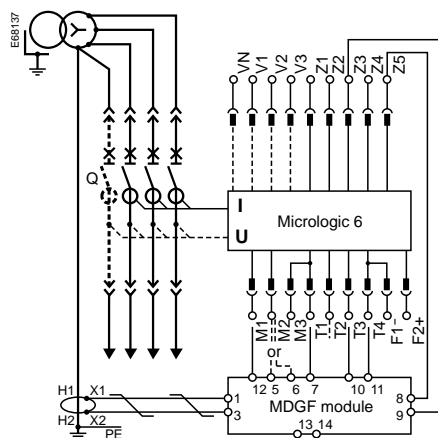

H1 is connected to source side and H2 to receiver side.

Catalog Numbers	
Current Transformateur SGR	33579

Ground Fault Protection with Compact CM

Zone selective interlocking

A pilot wire interconnects a number of circuit breakers equipped with Micrologic A/ P/H control units, as illustrated in the diagram above.

The control unit detecting a fault sends a signal from downstream, the circuit breaker remains closed for the full duration of its tripping delay. If there is no signal from downstream, the circuit breaker opens immediately, whatever the tripping-delay setting.

■ **Fault 1:**
only circuit breaker A detects the fault. Because it receives no signal from downstream, it immediately opens in spite of its tripping delay set to 0.3.

■ **Fault 2:**
circuit breakers A and B detect the fault. Circuit breaker A receives a signal from B and remains closed for the full duration of its tripping delay set to 0.3. Circuit breaker B does not receive a signal from downstream and opens immediately, in spite of its tripping delay set to 0.2.

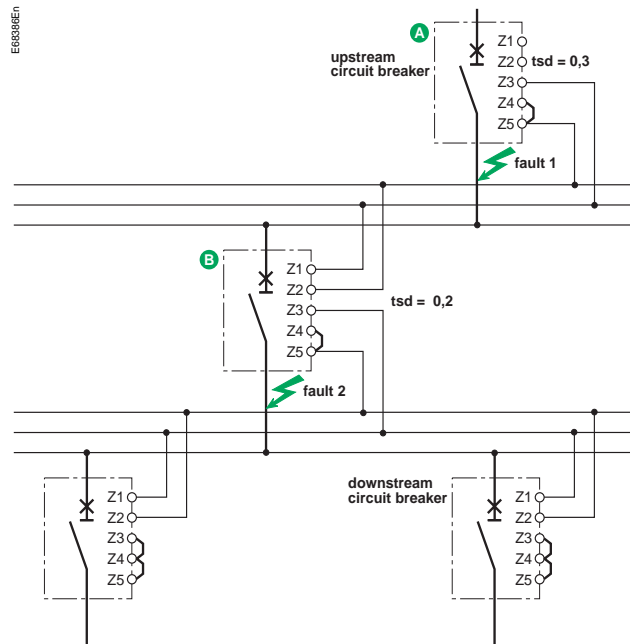

Note : the maximum length between two devices is 3000 m. The devices total number is 100 at the maximum.

External power-supply module

It makes possible to:

- Use the display even if the circuit breaker is open or not supplied.
- Powers both the control unit and the M2C and M6C programmable contacts .
- With Micrologic A, display currents of less than 20% of In.
- With Micrologic P/H, display fault currents after tripping and to time-stamp events (alarms and trips).

■ **Power supply :**
110/130, 200/240, 380/415 V AC (+10% - 15%), consumption 10 VA
24/30, 48/60, 100/125 V DC (+20% -20%), consumption 10 W.

■ **Output voltage:** 24 V DC, power delivered: 5W/5VA.

- Ripple < 5%
- Classe 2 isolation.

■ A Battery module makes it possible to use the display even if the power supply to the Micrologic control unit is interrupted.

Cabling precautions

- the cable length from the AD module to the Trip Unit must not be longer than 10 m.



Catalog Numbers	
External power-supply module	
24/30 V DC	54440
48/60 V DC	54441
125 V DC	54442
110 V AC	54443
220 V AC	54444
380 V AC	54445

Catalog Numbers	
Battery module	
Module BAT 24 V DC	54446

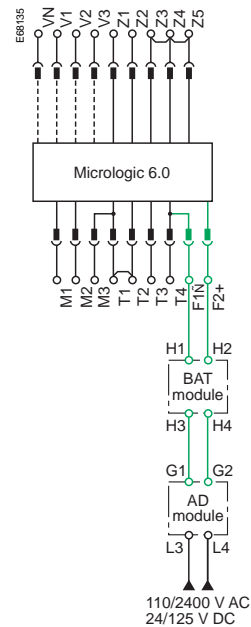

Technical data and Settings

STR53UE trip unit

The STR53UE trip unit is optionally equipped with Ground Fault Protection⁽¹⁾. This can be completed by the ZSI "Logic discrimination" option.

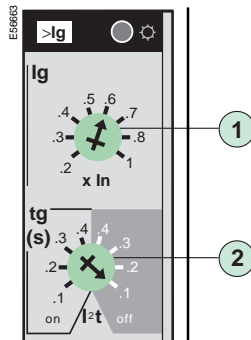
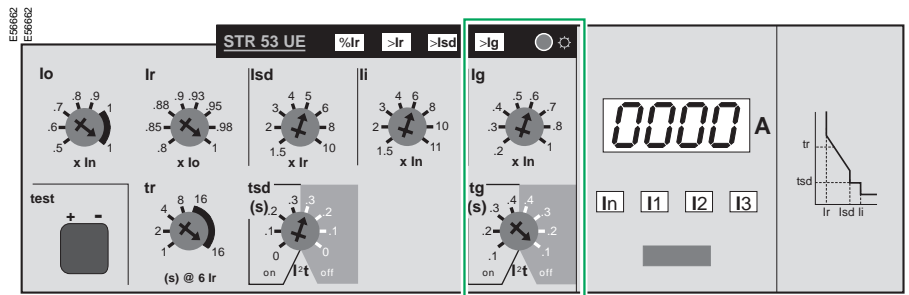

- 1 tripping threshold on Ground fault.
- 2 time delay on Ground fault and I^2t on/off.

(1) For Compact NS 100 to 630 A, Ground Fault Protection can be achieved in Zero Sequence up to 30 A by addition of a Vigi module.

Technical data of Ground Fault Protection for Compact C and Compact NS

Functions for Compact NS4400/630 "Ground Fault" protection (T)	STR53UE			
Type	residual current			
Tripping threshold I_g	adjustable (8 indexes) - 0.2 to 1 x I_n			
accuracy	± 15 %			
Tripping time	adjustable (4 indexes + function " $I^2t = cte$ ")			
maximum overcurrent time without tripping	60	140	230	350
total breaking time	£ 140	£ 230	£ 350	£ 500

Ground Fault Protection with the RH relays and toroids of the A, OA and E types

Technical data and settings

The protection provided is of the Zero sequence or Source Ground Return type. The RH relay acts on the MX or MN coil of the protection circuit-breaker.

RH328AP



Functions		RH328AP relays
Sensitivity I_{DN} number of thresholds		32: from 30 mA to 250 A, setting with 2 selectors
Time delay (ms)		0, 50, 90, 140, 250, 350, 500, 1s.
Early warning sensitivity		automatically set at $I_{DN}/2$
time delay		200 ms
Device test local		electronic + indicator light + contact
permanent		toroid/relay connection
Resetting		local and remote by breaking the auxiliary power supply
Local indication insulation fault and toroid link breaking by indicator light		by indicator light with latching mechanism
early warning		by indicator light without latching mechanism
Output contact fault contact	number	1 standard
	type of contact: changeover switches	with or without latching mechanism
early warning contact	number	1 with "failsafe" safety
	type of contact: changeover switches	without latching mechanism

Toroids



Toroids	Type A	λ (mm)	Type OA	λ (mm)	Type E	λ (mm)
Dimensions	TA	30	POA	46	TE30	30 (all thresholds)
	PA	50	GOA	110	PE50	50 (all thresholds)
	IA	80			IE80	80 (threshold \geq 300 mA)
	MA	120			ME120	120 (threshold \geq 300 mA)
	SA	200			SE200	200 (threshold \geq 300 mA)
	GA	300				

Cabling the Ground Fault Protection by Vigirex

Ground Fault Protection by Vigirex and associated Toroid controls the breaking device tripping coil: circuit-breaker or switch controlled.

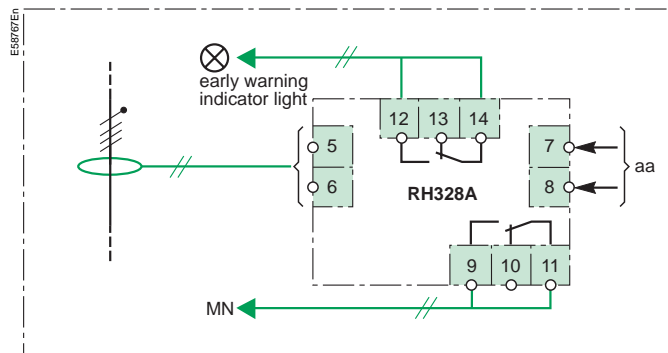

Vigirex cabling diagram

Implementation in the installation

EBB 1445n

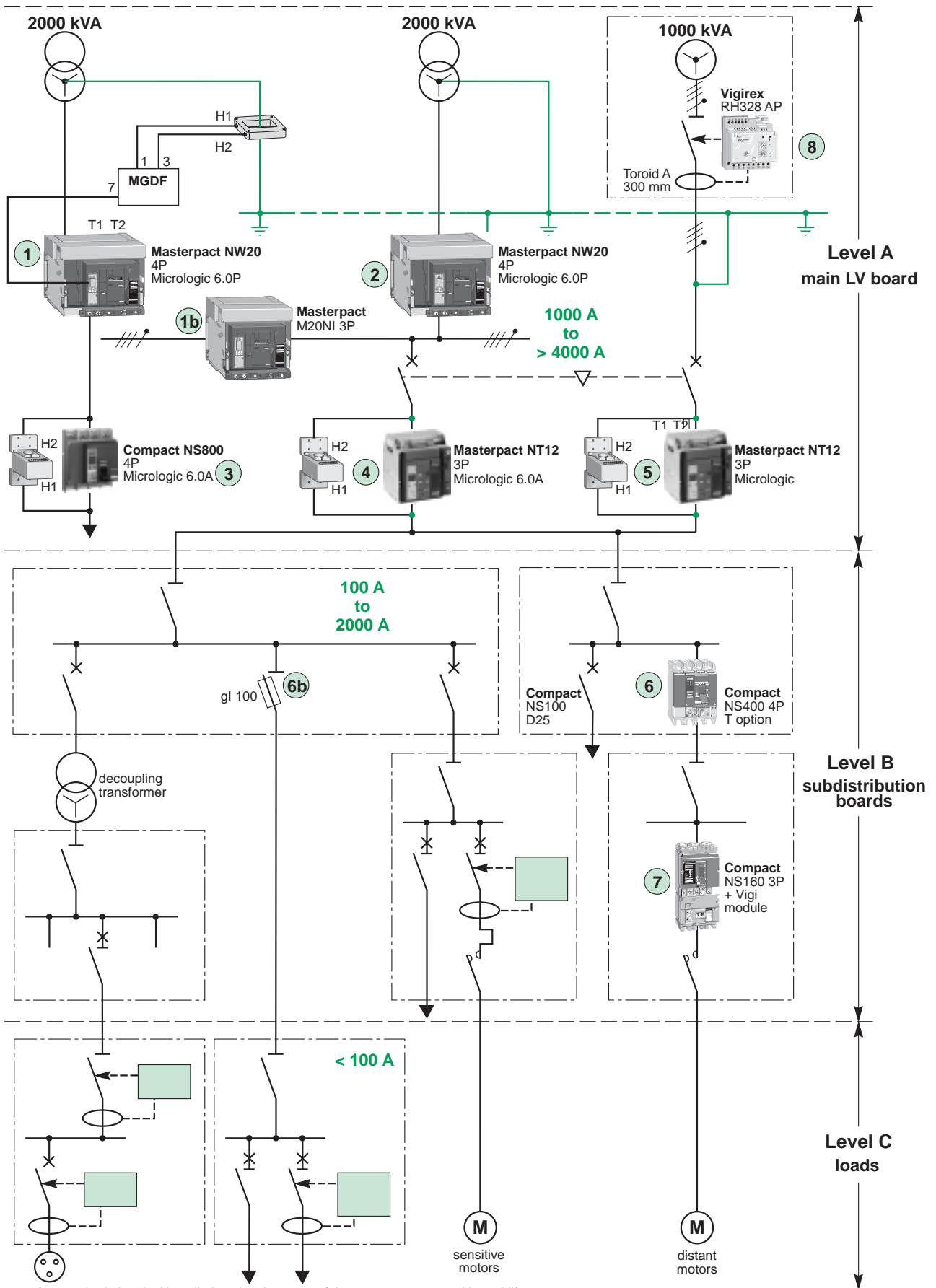

Diagram of a standard electrical installation showing most of the cases encountered in real life

Table summarising the GFP functions of the Merlin Gerin ranges

Standard GFP option

Type of GFP current range	Technical data	Masterpact NT 630 to 1600 A NW 800 to 6300 A	Compact NS 1600b to 3200 A	Compact NS 630b to 1600 A	Compact NS 400 to 630 A	Compact NS 100 to 250 A
Residual sensing	4P4D circuit breaker + current limit (* lower limit according to the rating)	Micrologic 6.0 A/P/H 1200 A (max.*) ± 10 %	Micrologic 6.0 A	Micrologic 6.0 A	STR53UE option T from 0,2 In to In	no
	time delay	Inst to 0,4 s (I ² t On or Off)			Inst. to 0,3 s	
	TCE	injustified			injustified	
	3P3D, 4P3D circuit breaker + current limit (* lower limit according to the rating)	Micrologic 6.0 A/P/H 1200 A (max.*) ± 10 %	Micrologic 6.0 A	Micrologic 6.0 A	no	no
	time delay	Inst to 0,4 s (I ² t On ou Off)				
	TCE ⁽¹⁾	yes ⁽²⁾				
Source Ground Return	4P4D, 3P3D, 4P3D circuit breaker + current limit (* lower limit according to the rating)	Micrologic 6.0 A/P/H 1200 A ± 10 %	Micrologic 6.0 A	Micrologic 6.0 A	no only by external relay (Vigirex)	no
	time delay	Inst to 0,4 s (I ² t On ou Off)				
	TCW ⁽³⁾ + MDGF	yes				
Zero Sequence	4P4D, 3P3D, 4P3D circuit breaker + current limit	Micrologic 7.0 A/P/H 0,5 to 30 A +0-20 %	Micrologic 7.0 A	Micrologic 7.0 A	only 4P4D+ internal Vigirex 300 mA to 30 A	30 mA to 3 A
	time delay	600 to 800 ms			Inst. to 0,3 s	Inst. to 0,3 s
	TCE	external			Internal	Internal

Option with Vigirex external relay

Type of GFP current range	Technical data	Masterpact NT 630 to 1600 A NW 800 to 6300 A	Compact NS 1600 to 3200 A	Compact NS 630 to 1600 A	Compact NS 400 to 630 A	Compact NS 100 to 250 A
Source Ground Return or Zero Sequence	3P3D, 4P3D, 4P4D circuit breaker + Vigirex relay + external current limit	30 mA to 250 A		30 mA to 250 A	30 mA to 250 A	30 mA to 250 A
	time delay	Inst to 1 s	Inst to 1 s	Inst to 1 s	Inst to 1 s	Inst to 1 s
	toroids 30 to 300 mm	yes	yes	yes	yes	yes

Option ZSI

Type of GFP current range	Technical data	Masterpact NT 630 to 1600 A NW 800 to 6300 A	Compact NS 1600 to 3200 A	Compact NS 630 to 1600 A	Compact NS 400 to 630 A	Compact NS 100 to 250 A
ZSI	3P3D, 4P3D, 4P4D circuit breaker by pilot wire	yes	yes	yes	yes	no

not feasible or unjustified

(1) If distributed Neutral conductor.

(2) TCE of the same rating as those installed in the circuit-breaker. To be positioned and connected with accuracy.

(3) TCW se connecte au Micrologic 6.0A/P/H/ par l'intermédiaire d'un boîtier MDGF summer.

Study of discrimination between GFP

The diagram on page 10 shows an industrial or tertiary LV electrical installation. The co-ordination rules must be implemented to guarantee safety and continuity of supply during operation.

Incoming circuit-breakers ① and ②, and coupling circuit-breaker ①b

- the incoming circuit-breakers are **four-pole**:
 - this is **compulsory** ⁽¹⁾ as both sources are grounded (Multisources / Multiple Groundings). Four-pole breaking eliminates circulation of natural currents via the PE conductor, thus easily guaranteeing a Ground Fault Protection free of malfunctions.
 - the coupling circuit-breaker ①b can be three-pole or four-pole ⁽¹⁾.

⁽¹⁾ if the diagram only had one grounding (e.g. at coupling level), the incoming and coupling circuit-breakers would have to be three-pole.

Discrimination of Ground Fault Protection

- in normal operation N, the discrimination rules between the incoming and outgoing circuit-breakers must be complied with for each source (S1 or S2),
- in Replacement R1 or R2 operation:
 - these must be applied to all the supplied outgoing (S1 and S2),
 - coupling can be equipped with a Ground Fault Protection function to improve discrimination (case of a fault on the busbar). This Protection must be selective both upstream and downstream. This is easily implemented if the ZSI function is activated,
 - switch or coupling circuit-breaker: when the Ground Fault Protection function is installed on the coupling, it may be provided by a circuit-breaker identical to the source protection devices. This ensures immediate availability on site of a spare part should one of the incoming circuit-breakers present an anomaly.

Time discrimination of the Ground Fault Protections

Implementation Examples

Example 1:

The time discrimination rules applied to Masterpact MW32 ② and NT12 ④ result in the settings described in the figure below. The indicated setting allows total discrimination between the 2 circuit-breakers.

Note: the time delay can be large at this level of the installation as the Busbars are sized for time discrimination.

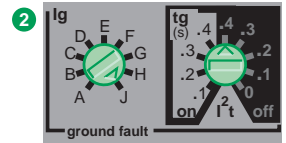
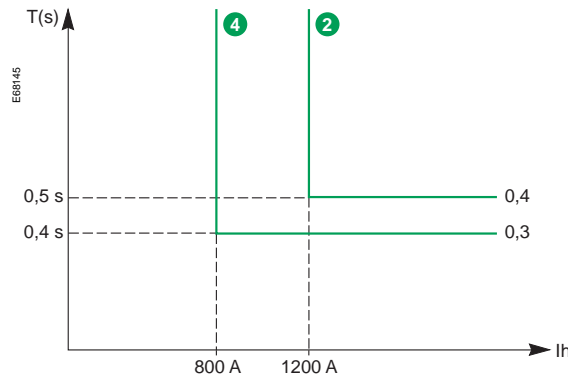

Micrologic 6.0A

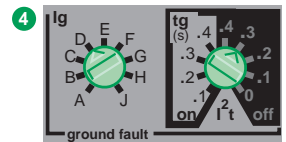

Micrologic 6.0P

Example 1a: optimised setting

Discrimination can be optimised by the implementation of the function "I't on". If we return to example 1, in event of a ground fault, discrimination between NT12 ④ and the gl 100 A fuse ⑥b is total.

Note: Ground Fault Protection is similar to a Phase/Neutral short-circuit protection.

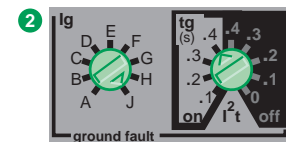
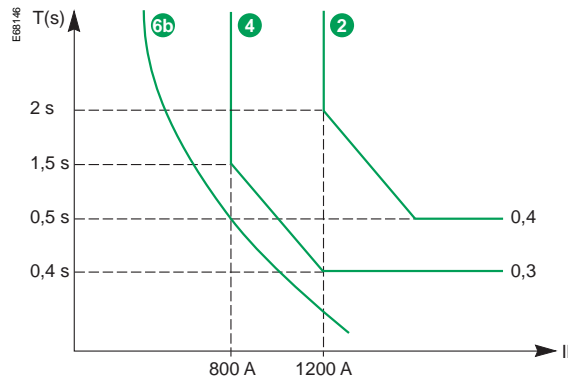

Micrologic 6.0A

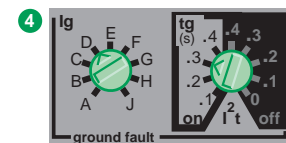

Micrologic 6.0A

Implementation examples

Example 2:

The discrimination rules applied to Masterpact MW32 **1** and Compact NS800 **3** result in the settings described in the figure below. The indicated setting allows total discrimination between the 2 circuit-breakers.

Note: time discrimination upstream does not present problems. On the other hand, downstream time discrimination is only possible with short-circuit protection devices with a rating \geq than 40 A. Use of the "I²t on" function improves this limit for the gI fuses placed downstream (see example 1a).

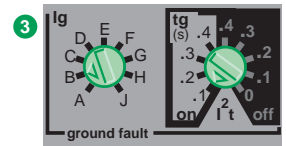
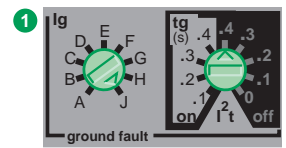
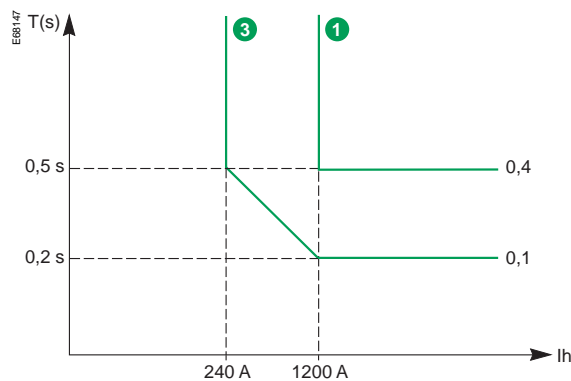

Micrologic 6.0A

Example 1b: optimised discrimination

Going back to example 1, on a fault downstream of circuit-breaker **7**, the Ground Fault Protections **4**, **6** and **7** are in series. Installation of a Vigicompact NS160 **7** allows total discrimination of the Ground Fault Protections as standards whatever the setting I_r of the Vigicompact NS 160.

Note: although thresholds may be very different (I_g = 400 A for NS400, I_g = 30 A for NS160), it is necessary to comply with time delay rules between protection devices (index 0.2 for NS400, index 0.1 for NS160).

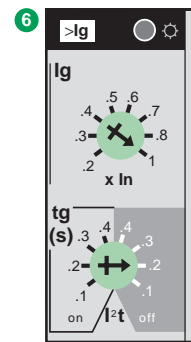
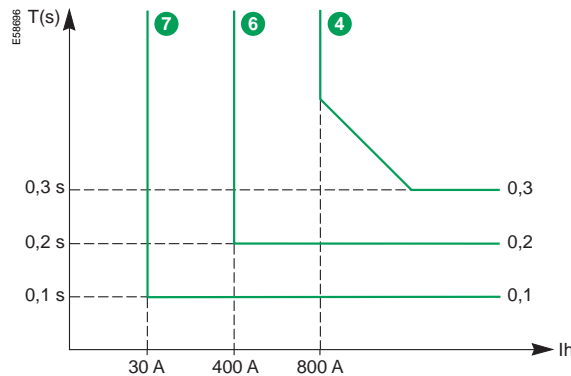

Special use of Ground Fault Protection

Generator protection

The principle

The Vigirex RH328 AP **9** is installed as generator protection. The principle of this protection is as follows:

- tripping in event of a ground fault **upstream** (protected area),
- non tripping in event of a ground fault **downstream** (unprotected area),

The constraints

The protection functions must:

- be very fast to avoid deterioration of the generator (and must control stopping and placing out of operation of the GE),
- be very fast to maintain continuity of supply (and must control the coupling device of the GE). This function is important in event of parallel-connected generators,
- have an average tripping threshold: normally from 30 A to 250 A. On the other hand, discrimination with the Ground Fault Protections of the installation is "naturally" provided (no effect on the "unprotected area"),

Setting of the protection device

Due to the above constraints, setting can be:

- threshold I_{Dn}: from 30 A to 250 A,
- time delay: instantaneous.

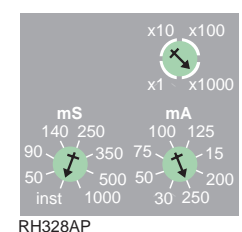
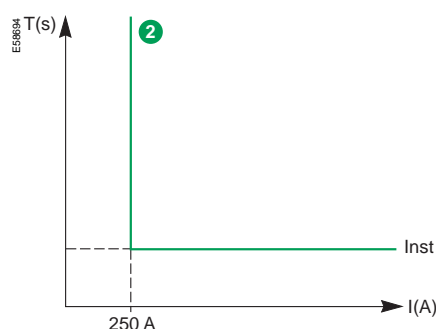
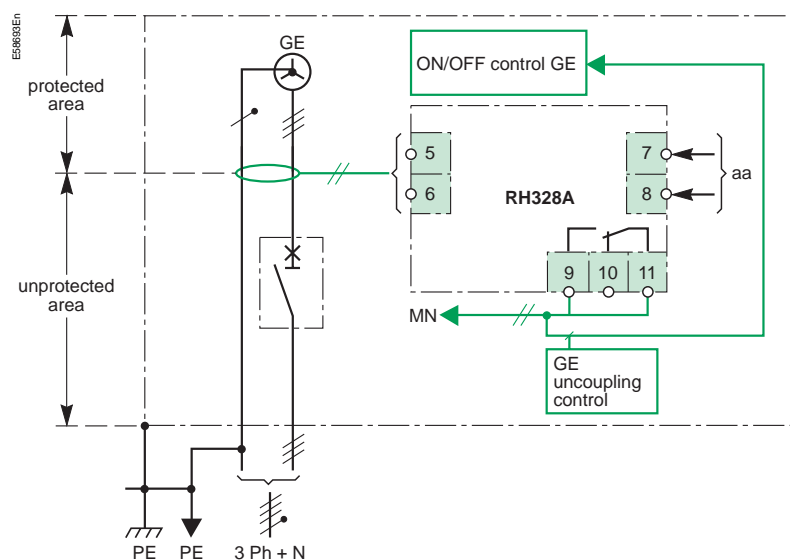

RH328AP

Additional technical information

Study of ZSI discrimination

Principle

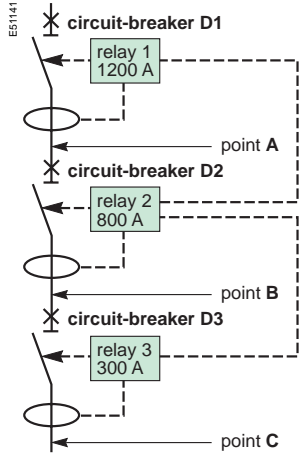

This type of discrimination can be achieved with circuit-breakers equipped with electronic control units designed for this purpose (Compact, Masterpact): only the Short Delay Protection (SD) or Ground Fault Protection (GFP) functions of the controlled devices are managed by Logic Discrimination. In particular, the Instantaneous Protection function - intrinsic protection function - is not concerned.

Settings of the controlled circuit-breakers

- time delay: the staging rules of the time delays of time discrimination must be applied,
 - thresholds: there are no threshold rules to be applied, but it is necessary to respect the natural staging of the ratings of the protection devices ($I_{crD1} > I_{crD2} > I_{crD3}$).
- Note:** this technique ensures discrimination even with circuit-breakers of similar ratings.

Principle

The Logic Discrimination function is activated by transmission of information on the pilot wire:

- ZSI input:
 - low level (no faults downstream): the protection function is on standby with a reduced time delay (≈ 0.1 s),
 - high level (presence of faults downstream): the Protection function in question moves to the time delay status set on the device,
- ZSI output:
 - low level: the circuit-breaker does not detect any faults and sends no orders,
 - high level: the circuit-breaker detects a fault and sends an order.

Operation

Chronogram

ES0937

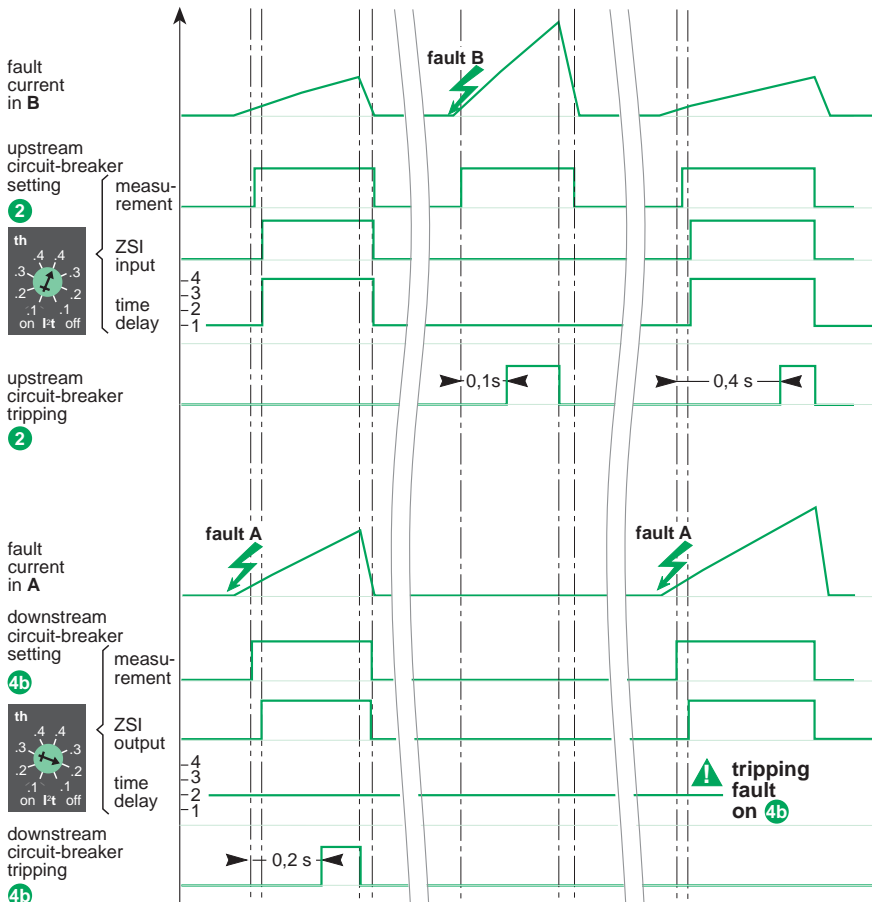
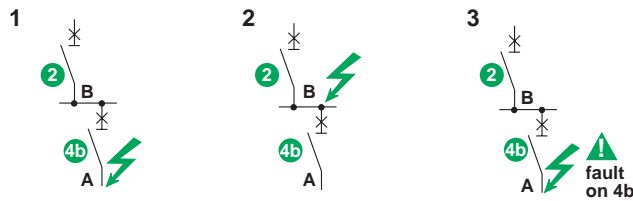

The analysis is conducted based on the diagram on page 46 showing the 2 Masterpacts 2 and 4b.

Masterpact settings

	time delay	threshold
4	index .4	< 1200 A
4 b	index .2	< 1200 A ⁽¹⁾

(1) complying with the rules stated above.

The downstream Masterpact 4b also has input ZSI shunted (ZSI input at "1"); consequently it keeps the time delay set in local (index .2) in order to guarantee time discrimination to the circuit-breakers placed downstream.

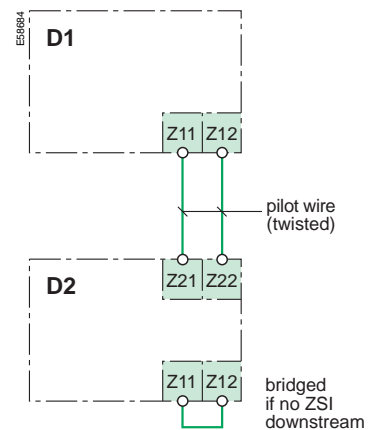

Operation

The pilot wire connects the Masterpact in cascade form. The attached chronogram shows implementation of the ZSI discrimination between the 2 circuit-breakers.

■ **case 1**

When a fault occurs in A, the 2 circuit-breakers detect it. The Masterpact ④ sends an order (ZSI output moves to the high level) to the ZSI input of the Masterpact ②. The time delay of Masterpact ② moves to its natural time delay index .4. Masterpact ④ trips after its time delay (index .2) and eliminates the fault.

■ **case 2**

The fault is located in B. Masterpact ② receives no ZSI information (input at low level). It detects the fault and eliminates it after its ZSI mini time delay of 0.1s. The constraints on the busbar are considerably fewer than for implementation of conventional time discrimination.

■ **case 3**

In event of an anomaly on circuit-breaker ④ protection is provided by the upstream Masterpact:

- in 0.1 s if the downstream circuit-breaker has not detected the fault,
- at the natural time delay of the upstream Masterpact (0.4 s for our example) if there is an anomaly of the downstream circuit-breaker (the most unfavourable case)

Multisource diagram with ZSI function

EG8133

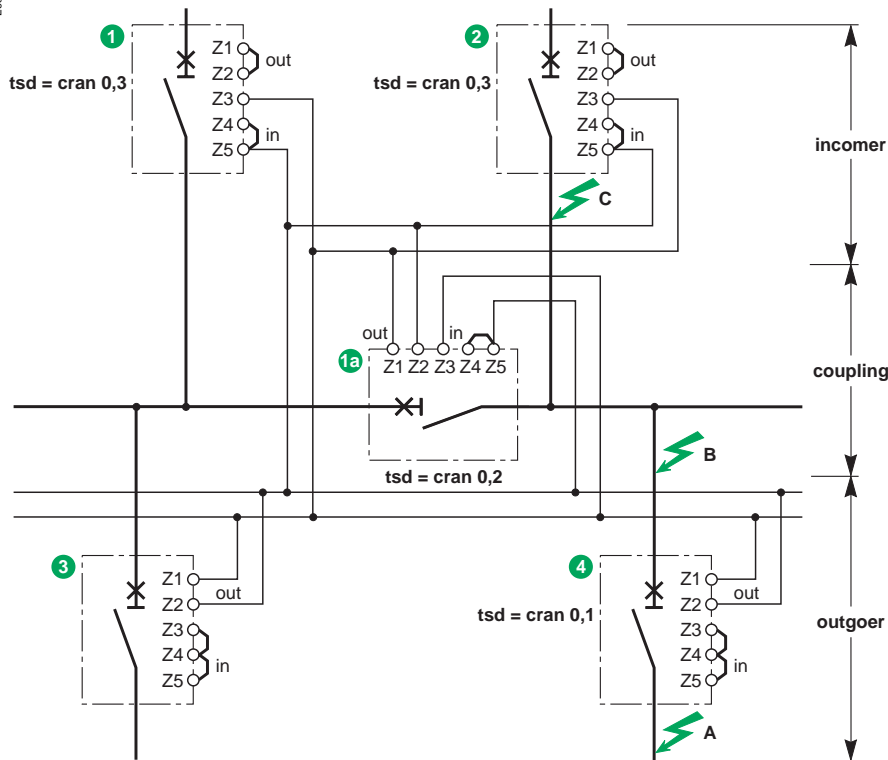

Pilot wire installation precautions

- length: 300 m,
- conductor type: twisted,
- number of devices:
 - 3 upstream devices,
 - 10 downstream devices.

Analysis of operation

The Masterpacts are connected according to their position in the installation:

- Masterpact ① and ② : index .4,
- Masterpact ①a : index .3,
- Masterpact ③ and ④: index .2.

The Masterpacts ③ and ④ have their ZSI input shunted (ZSI input at the high level).

■ **Normal N operation**

An insulation fault occurs downstream of the Masterpact ④ .

- the Masterpact ④ :
 - detects the fault,
 - sends a message to the upstream of the Masterpact ①, ② and ①a ,
 - does not receive any information,
- the Masterpacts ② and ①a receive the information but do not detect the fault; they are not concerned,
- the Masterpact ① receives the information and detects the fault: it moves to the standby position with a time delay at index 0.4,
- the Masterpact ④ eliminates the fault after the time delay index .2 and the system returns to its normal status.

■ **Replacement R2 operation**

the Masterpact ② is open, the Masterpacts ① and ①a are closed; an insulation fault occurs downstream of Masterpact ④ :

- the Masterpact ④ :
 - detects the fault,
 - sends a message to the upstream to Masterpacts ①, ② and ①a ,
 - does not receive any information,
- the Masterpact ② receives the information but is not in operation; it is not concerned,
- the Masterpacts ① and ①a receive the information and "see" the fault; they move to the standby position with a time delay at index 0.4 for ① and index 0.3 for ①a,
- the Masterpact ④ eliminates the fault after the time delay 0.1 and the system returns to its normal status.

Notes

Schneider Electric Industries SA

5, rue Nadar
92506 Rueil Malmaison - Cedex France
Tel : +33 (0)1 41 29 82 00
Fax : +33 (0)1 47 51 80 20

<http://www.schneiderelectric.com>

DBTP140GUI/EN

As standards, specifications and designs develop from time to time, always ask for confirmation of the information given in this publication.



This document has been printed on ecological paper.

Published by: Schneider Electric
Designed by: AMEG
Printed by:

07/00