

# Field Testing and Maintenance Guide

for Thermal-Magnetic and Micrologic™ Electronic-Trip Circuit Breakers



**Guía de servicio de mantenimiento y pruebas en campo**  
de los interruptores termomagnéticos y de disparo electrónico Micrologic™

**Guide d'essai sur place et d'entretien**

pour disjoncteurs thermomagnétiques et à déclenchement électronique  
Micrologic<sup>MC</sup>

Instruction Bulletin  
Boletín de instrucciones  
Directives d'utilisation

06001B1201 R07/13  
08/2013

Retain for Future Use. /  
Conservar para uso futuro. /  
À conserver pour usage ultérieur.





# Field Testing and Maintenance Guide

## for Thermal-Magnetic and Micrologic™ Electronic-Trip

### Circuit Breakers

### Class Number 0600

Instruction Bulletin  
0600IB1201 R07/13  
08/2013  
Retain for future use.



## Hazard Categories and Special Symbols

Read these instructions carefully and look at the equipment to become familiar with the device before trying to install, operate, service or maintain it. The following special messages may appear throughout this bulletin or on the equipment to warn of potential hazards or to call attention to information that clarifies or simplifies a procedure.



The addition of either symbol to a “Danger” or “Warning” safety label indicates that an electrical hazard exists which will result in personal injury if the instructions are not followed.



This is the safety alert symbol. It is used to alert you to potential personal injury hazards. Obey all safety messages that follow this symbol to avoid possible injury or death.

### **⚠ DANGER**

**DANGER** indicates an imminently hazardous situation which, if not avoided, **will result in** death or serious injury.

### **⚠ WARNING**

**WARNING** indicates a potentially hazardous situation which, if not avoided, **can result in** death or serious injury.

### **⚠ CAUTION**

**CAUTION** indicates a potentially hazardous situation which, if not avoided, **can result in** minor or moderate injury.

### **NOTICE**

**NOTICE** indicates a potentially hazardous situation which, if not avoided, **can result in** property damage.

**NOTE:** Provides additional information to clarify or simplify a procedure.

## Please Note

Electrical equipment should be installed, operated, serviced, and maintained only by qualified personnel. No responsibility is assumed by Schneider Electric for any consequences arising out of the use of this material.

# Table of Contents

- Section 1—Introduction** ..... 7
  - Inspection and Testing ..... 7
    - Thermal-Magnetic Circuit Breaker Testing Inaccuracies ..... 8
  - Safety Precautions ..... 8
- Section 2—Visual Inspection and Preventive Maintenance** ..... 9
  - Molded Case of Circuit Breakers ..... 9
  - Procedures ..... 9
    - Visual Inspections During Operation ..... 9
    - Maintenance Inspections ..... 10
    - Thermographic Inspection ..... 11
    - Additional Information ..... 11
- Section 3—Performance Tests for Thermal-Magnetic Circuit Breaker** ..... 12
  - General Circuit Breaker Performance Tests ..... 12
    - Field Testing Special 500 Vdc Circuit Breakers ..... 12
    - Field Testing AC Thermal-Magnetic Circuit Breakers ..... 13
  - Performance Tests ..... 13
    - Insulation Resistance Test ..... 13
    - Thermal-Magnetic Circuit Breaker Performance Tests ..... 14
  - Remove Test Connections ..... 17
  - Additional Information ..... 17
- Section 4—Performance Tests for PowerPact™ Circuit Breakers** ..... 18
  - Performance Tests ..... 18
    - Insulation Resistance Test (Dielectric Testing) ..... 18
    - Micrologic™ Trip Unit Checks ..... 19
    - Procedure to Defeat Zone-Selective Interlocking ..... 19
  - Secondary Injection ..... 19
  - Primary Injection Testing ..... 19
    - Circuit Breakers with Integral Ground Fault Protection ..... 22
    - Ground-Fault Protection and Indication
      - Only Tests for Radial Systems ..... 22
  - Remove Test Connections ..... 24
  - Additional Information ..... 25
- Section 5—Performance Tests for Electronic Trip Legacy LE/LX, ME/MX, PE/PX, and SE Circuit Breaker** ..... 26
  - General Circuit Breaker Performance Tests ..... 26
  - Micrologic™ Electronic-Trip Circuit Breaker Tests ..... 27
    - Circuit Breakers with Integral Ground Fault Protection ..... 29
    - Procedure for Circuit Breakers Used with Powerlogic™ Systems ..... 30
    - Procedure to Defeat Zone-Selective Interlocking ..... 30
    - Ground-Fault Protection and Indication
      - Only Tests for Radial Systems ..... 31
  - Remove Test Connections ..... 34
  - Additional Information ..... 34
- Section 6—Available Test Equipment** ..... 35
  - Test Equipment for L-, M-, N-, P- and S-Frame Circuit Breakers with Micrologic™ Trip Units ..... 35
    - Local Current Meter Kit ..... 35
    - Memory-Reset Module ..... 35
    - Primary Injection Test Kit ..... 35

---

Universal Test Set .....	35
Full-Function Test Kit .....	36
Hand-Held Test Kit .....	36
Available Test Equipment for PowerPact H/J/L Circuit Breakers with Micrologic Electronic-Trip Units .....	36
Pocket Tester .....	36
UTA Tester for Test and Maintenance .....	37

## Section 1—Introduction

### Inspection and Testing

The service life of molded case circuit breakers depends on proper application, correct installation, environmental conditions and preventive maintenance. Two levels of investigation can ensure that a circuit breaker is able to operate properly:

1. Inspection and preventive maintenance
2. Performance and verification tests.

To ensure continued suitable performance, periodically inspect the circuit breakers following the procedures outlined in this document. These test procedures will help diagnose operational problems and are provided as an aid or as follow-up to an inspection that reveals potential problems. The inspection, preventive maintenance, and field-testing instructions provided in this document are intended for use with electronic-trip molded-case circuit breakers with the Micrologic™ trip system, thermal-magnetic circuit breakers, and magnetic-only circuit breakers.

**Table 1: Circuit Breaker Inspection and Testing**

Circuit Breaker Type	Inspection	Performance Tests
Thermal-Magnetic Circuit Breakers	Section 2	Section 3
Magnetic-Only Circuit Breakers	Section 2	Section 3
PowerPact™ Circuit Breakers	Section 2	Section 4
Electronic Trip (Except for Masterpact and PowerPact) Circuit Breakers	Section 2	Section 5

For information on maintenance and testing of insulated case Masterpact circuit breakers, see bulletin 0613IB1202, Maintenance and Field Testing Guide for Masterpact NT and NW Circuit Breakers.

The standard generally used as a basis for field-testing requirements is the National Electrical Manufacturers Association Standard, NEMA AB 4, "Guidelines for Inspection and Preventive Maintenance of Molded Case Circuit Breakers Used in Commercial and Industrial Applications." If additional information or assistance is required, contact your local field sales office. For on-site service, contact the Customer Information Center twenty-four hours a day at 1-888-778-2733.

The inspection and preventive maintenance procedures outlined in this publication may be useful in setting up a routine inspection program. Conduct performance tests only if inspection or daily operation indicates that a circuit breaker may not be adequately providing the protection required by its application.

If questionable results are observed during inspection or performance tests, consult your local field sales office. If it is necessary to return a circuit breaker to the manufacturing facility, use proper packaging and packing materials to avoid shipping damage.

This publication is not intended, nor is it adequate, to verify proper electrical performance of a molded case circuit breaker that has been disassembled, modified, rebuilt, refurbished, or handled in any manner not intended or authorized by Schneider Electric.

## Thermal-Magnetic Circuit Breaker Testing Inaccuracies

During the last few years there have been increasing incidents of inaccurate field testing. Major obstacles to accurate field testing of circuit breakers are the variables present in modern installations, such as variations in enclosures, bussing, cabling and proximity to other equipment.

Another obstacle is Vac vs. Vdc test currents for direct current applications. Most manufacturers have tested and certified ac circuit breakers for use in low-voltage dc applications (250 Vdc or less). When applying thermal-magnetic circuit breakers, 1000 A frame or less, on low-voltage (< 250 Vdc systems) the circuit breaker's thermal characteristics remain unchanged. But the magnetic (instantaneous) characteristics do change and require a multiplier to determine the dc current necessary to trip the circuit breaker. The multipliers for use with Square D™ equipment are shown in the *Determining Current Carrying Capacities in Special Applications* data bulletin.

For circuit breakers above 1000 A and 500 Vdc circuit breakers, the correlation between ac current and dc current is not predictable. For accurate results, these circuit breakers must be tested using dc current. See "Field Testing Special 500 Vdc Circuit Breakers" on page 12 for testing information.

## Safety Precautions

1. Only qualified electrical workers with training and experience on low-voltage circuits should perform work described in these instructions. Workers must understand the hazards involved in working with or near low-voltage equipment. Such work should be performed only after reading this complete set of instructions.
2. Some inspections or procedures require that certain parts of the electrical system remain energized at hazardous voltage during the procedure. Observe all specific safety messages (Danger, Warning, Caution) throughout this manual.
3. Wear protective safety equipment, recognize potential hazard, and take adequate safety precautions when performing the procedures outlined in this manual.

## Section 2—Visual Inspection and Preventive Maintenance

Molded case circuit breakers normally require very little maintenance. The Company recommends that inspection procedures be performed on a regular basis. Inspection frequency depends on operating and environmental conditions associated with the application.

Visual inspections during operation can be performed any time electrical workers or maintenance personnel are in the vicinity of the electrical equipment.

Maintenance inspections can be done during normal maintenance intervals. It is recommended that the circuit breaker mechanism be exercised annually. Inspection and maintenance may be required more frequently if adverse operating or environmental conditions exist.

### Molded Case of Circuit Breakers

The molded case of a Square D molded case circuit breaker should not be opened. Opening the case or disassembling the circuit breaker voids the manufacturer's warranty and compromises the integrity of the device. Opened or otherwise inoperable circuit breakers should be destroyed or returned to the Company to prevent them from being returned to service. Removal of auxiliary or accessory covers does not constitute opening the molded case.

### Procedures

#### Visual Inspections During Operation

<p><b>⚠ DANGER</b></p> <p><b>HAZARD OF ELECTRIC SHOCK, EXPLOSION, OR ARC FLASH</b></p> <ul style="list-style-type: none"><li>• Apply appropriate personal protective equipment (PPE) and follow safe electrical work practices. See NFPA 70E or CSA Z462.</li><li>• This equipment must be installed and serviced by qualified electrical personnel.</li><li>• Take precautions to ensure that no accidental contact is made with live components during this check.</li></ul> <p><b>Failure to follow these precautions will result in death or serious injury.</b></p>
--

While circuit breaker is energized:

1. Verify circuit breaker application and rating.  
Make sure that the circuit breaker is properly applied within labeled voltage, ampere rating, maximum current interrupting ratings and to Company recommendations. Compare the circuit breaker faceplate data to the installation drawings. Verify trip unit settings on Micrologic™ electronic-trip circuit breakers with the coordination study. After completing inspection and maintenance procedures, insure that all trip unit settings for all functions are set according to the coordination study.
2. Check for overheating while equipment is energized.  
While the circuit breaker is normally operating, under load and at operating temperature, check the exposed, accessible, insulated face of the circuit breaker and adjacent dead front surfaces of the enclosure for overheating. To do this, use an infrared temperature probe to check the temperature. If the temperature exceeds 60°C, the cause should be investigated.  
Allow initially energized circuit breaker at least three hours to reach operating temperature. Compare the surface temperature of individual circuit breakers with the surface temperature of other circuit breakers in the installation. Circuit breaker surface temperatures vary according to loading, position in the panelboard and ambient temperature. If the surface temperature of a circuit breaker is considerably higher than adjacent circuit breakers, the cause should be investigated.  
Thermographic inspection methods may also be used to evaluate overheating with equipment energized (see Thermographic Inspection, 11).
3. Check for cracks in the molded case.  
Any circuit breaker with a cracked molded case should be replaced because its ability to withstand short-circuit interruption stresses is reduced.
4. Inspect the enclosure.  
The enclosure should be clean and dry. All covers and trip pieces should be in place.

## Maintenance Inspections

### **⚠ DANGER**

#### **HAZARD OF ELECTRIC SHOCK, EXPLOSION, OR ARC FLASH**

- Apply appropriate personal protective equipment (PPE) and follow safe electrical work practices. See NFPA 70E or CSA Z462.
- This equipment must be installed and serviced by qualified electrical personnel.
- Disconnect all power sources before performing maintenance inspections. Assume that all circuits are live until they are completely de-energized, tested, grounded and tagged. Consider all sources of power, including the possibility of backfeeding and control power.
- Always use a properly rated voltage sensing device to confirm power is off.
- Replace all devices, doors and covers before turning on power to this equipment.

**Failure to follow these precautions will result in serious injury or death.**

### **NOTICE**

#### **HAZARD OF EQUIPMENT DAMAGE**

Drawout connection lubrication must be reapplied each time the circuit breaker is removed from the cradle.

**Failure to follow these instructions can result in equipment damage**

While circuit breaker is de-energized:

1. Check for overheating while the equipment is de-energized.

Visually inspect electrical components for discoloration. This may indicate overheating. If there is no evidence of overheating or loose connections, do not disturb or re-torque connections.

Copper Connections:

If evidence of overheating is found on terminals, connectors, conductors or conductor insulation, clean and dress all affected connections and bus bars to NEMA Standards Publication AB4.

Aluminum Connections:

Overheated aluminum connectors must be replaced and damaged portions of the conductor removed. If the conductor is not long enough to properly terminate the circuit breaker when the damaged portion is removed, make an appropriate splice using a new length of rated conductor.

I-Line™ Panelboard Connections:

If the I-Line panelboard jaw connections are pitted, discolored or deformed, the circuit breaker must be replaced. I-Line jaws are gauged and tested during the manufacturing process. They are not field replaceable. Do not bend or adjust them.

If electrical joint compound is removed from I-Line connections, it must be reapplied before reinstallation of the circuit breaker(s). This compound is necessary to ensure the integrity of the connection. I-Line panelboard connections require Square D PJC-7201 joint compound.

Drawout Connections:

If circuit breaker drawout connections are discolored or deformed, the circuit breaker must be replaced.

Drawout connections must have lubrication applied each time the circuit breaker is removed from the cradle. This compound is necessary to ensure the integrity of the connection.

Drawout connections for SE circuit breakers require Square D PJC-8311 joint compound.

Drawout connections for PowerPact circuit breakers require grease kit S48899 to lubricate clusters and stabs.

After cleaning and/or replacing damaged parts, torque all connections to values specified by Square D. Refer to circuit breaker instruction bulletins for additional information regarding torque values. Bulletins are shipped with the circuit breakers and are available from the Square D internet technical library.

2. Exercise circuit breaker mechanism:

Toggle the circuit breaker handle on and off several times to ensure that mechanical linkages are free. Trip the circuit breaker with the push-to-trip button. Reset and turn the circuit breaker back on. Repeat to ensure operability. If the circuit breaker does not trip, or if it does not reset after tripping, it must be replaced.

3. Clean the circuit breaker.

Remove any buildup of dust, dirt, grease or moisture from circuit breaker surfaces with a lint-free dry cloth or vacuum cleaner. Do not use

compressed air. Use caution when using detergent-based cleaners or solvents: these may deteriorate faceplate, labels, and insulation materials. Clean contact surfaces of circuit breaker terminals and terminal pads or bus bars with a nonabrasive cleaner. Abrasive cleaners will remove plating, resulting in joint deterioration.

If electrical joint compound is removed from I-Line or SE drawout connections, Square D PJC-7201 or PJC-8311 joint compound, respectively, must be reapplied before reinstalling the circuit breakers. This compound is necessary to ensure the integrity of the connection.

### Thermographic Inspection

#### **⚠ DANGER**

##### **HAZARD OF ELECTRIC SHOCK, EXPLOSION, OR ARC FLASH**

Only qualified electrical workers with training and experience on low-voltage circuits should perform thermographic inspections. These workers must understand the hazards involved in working with or near low-voltage equipment. Perform such work only after reading this complete set of instructions.

**Failure to follow this precaution will result in death or serious injury.**

Infrared thermographic inspection techniques may be useful in evaluating the operating condition of circuit breakers and terminations. Comparison to stored infrared thermographic images may be useful for the preventive maintenance of circuit breakers and end-use equipment. The actual amount of heat emitted is a function of both load current and ambient conditions. Interpretation of infrared survey requires experience and training in this type of inspection.

Allow initially energized circuit breakers at least three hours to reach operating temperature. Compare the thermographic images of individual circuit breakers to previously stored images of the same circuit breakers.

### Additional Information

For more information concerning Square D circuit breakers, refer to the appropriate instruction manual. These manuals contain installation instructions, mounting information, safety features, wiring diagrams, and troubleshooting charts for specific circuit breakers.

## Section 3—Performance Tests for Thermal-Magnetic Circuit Breaker

### General Circuit Breaker Performance Tests

#### **⚠ DANGER**

##### **HAZARD OF ELECTRIC SHOCK, EXPLOSION, OR ARC FLASH**

- Apply appropriate personal protective equipment (PPE) and follow safe electrical work practices. See NFPA 70E or CSA Z462.
- This equipment must be installed and serviced by qualified electrical personnel.
- Turn off all power supplying this equipment before working on or inside equipment.
- Always use a properly rated voltage sensing device to confirm power is off.
- Replace all devices, doors and covers before turning on power to this equipment.
- Do not touch the circuit breaker terminals or the test leads while the circuit breaker is being tested.

**Failure to follow these instructions will result in death or serious injury.**

### Field Testing Special 500 Vdc Circuit Breakers

These tests check the performance of thermal-magnetic trip molded case circuit breakers.

Do the performance tests in the order given to maximize the accuracy of the test results.

**NOTE:** Never do the contact resistance test before doing the instantaneous primary injection testing. The primary injection testing will ensure the contacts are clear of resistive films, oxidation and foreign material.

The following tests are intended to verify that a circuit breaker is operating properly. Precisely controlled factory testing conditions are used to establish the characteristic trip curves. If field test results fall outside the characteristic trip curve tolerance band, carefully evaluate the test conditions and methods for accuracy.

When questionable conditions or results are observed during inspection and performance tests, consult your local field sales office. Circuit breakers with accessories or factory modifications may require special investigation. If it is necessary to return a circuit breaker to the manufacturing facility, use proper packaging and packing materials to avoid shipping damage.

Square D UL® Listed 500 Vdc circuit breakers are designed, manufactured and calibrated for use on ungrounded uninterruptable power supplies (UPS). The maximum nominal (loaded) voltage is 500 Vdc and the maximum floating (unloaded) voltage is 600 Vdc.

These circuit breakers are UL Listed when applied with all three poles connected in series as shown on the label of the circuit breaker. The series connection is customer provided and external to the circuit breaker.

Square D UL Listed 500 Vdc circuit breakers are special circuit breakers for dc applications only and must be tested using dc current.

- Select the correct time-current trip curve. The trip curves show both the thermal and magnetic trip ranges of the circuit breakers.
- Use a dc power supply to test the circuit breakers as follows:

Circuit Breaker	Time Constant <sup>1</sup>
≤ 400 A dc	≤ 20 ms
450–2500 A dc	≤ 25 ms

dc ripple constant ≤ 1% rms.

<sup>1</sup> Time constant is defined by UL 489 as "The time constant of the circuit is the time measured on the oscillogram where the current is 63.2 percent of the prospective current."

- Make sure ambient temperature and circuit breaker temperature is 25° C ± 3 degrees.

- Remove the circuit breaker from the enclosure. If removing the circuit breaker is not practical, test the circuit breaker in the end-use equipment. If the test results fall outside of the trip curve tolerance, remove the circuit breaker from the enclosure and retest.
- Use correctly sized cable (per National Electrical Code® [NEC®] tables) with a minimum of four feet (1.22 m) of cable per connection.
- Connect dc power supply to circuit breaker with all poles connected in series as shown on the circuit breaker label.
- Make sure connections to circuit breaker are properly torqued.
- Apply dc test current to trip the circuit breaker. The tripping mechanism in the circuit breaker reacts to the magnetic fields created by the current flowing through the circuit breaker. Apply a dc test current to the circuit breaker of approximately 70% of the expected value. If the circuit breaker does not trip, increase the test current on successive trials until it does trip. When the circuit breaker trips
  - a. Reset and close the circuit breaker.
  - b. Reapply the dc test current to trip the circuit breaker again.
  - c. Record the current and compare to the trip curve.

## Field Testing AC Thermal-Magnetic Circuit Breakers

Recommended steps to accurately field test circuit breakers (see test procedures in this manual for specific information):

- Use correct test equipment.
- Make sure ambient temperature and circuit breaker temperature is  $25^{\circ}\text{C} \pm 3$  degrees.
- Remove the circuit breaker from the enclosure. If removing the circuit breaker is not practical, test the circuit breaker in the end-use equipment. If the test results fall outside of the trip curve tolerance, remove the circuit breaker from the enclosure and retest.
- Use correctly sized cable (per NEC tables) with a minimum of four feet (1.22 m) of cable per connection.
- Test each pole individually.
- Make sure connections to circuit breaker are properly torqued.
- Test circuit breaker and record findings. The tripping mechanisms in the circuit breaker react to the magnetic fields created by the current flowing through the circuit breaker. When current flow is near the trip point of the circuit breaker, the magnetic fields can cause false tripping due to vibration. Do the following steps to minimize the effects of false tripping:
  - a. After each current pulse or when circuit breaker trips, reset and turn the circuit breaker on.
  - b. Reapply the test current to trip the circuit breaker again.
  - c. Record the current and compare to the trip curve.

## Performance Tests

### Insulation Resistance Test

Severe environmental conditions can reduce the dielectric strength of molded case circuit breakers. Check insulation resistance during electrical system testing.

To check the insulation resistance, perform the following steps:

1. De-energize and isolate the circuit breaker.
2. Clean the circuit breaker as described earlier.

## NOTICE

### HAZARD OF EQUIPMENT DAMAGE

Do not apply test voltage to control circuits or accessory terminals; damage to electronic and/or low-voltage components can result.

**Failure to follow these instructions will result in equipment damage.**

3. Using a megohmmeter with a capacity of 500–1000 Vdc, apply voltage from:
  - a. Each phase-to-ground with the circuit breaker on (circuit breaker contacts closed).
  - b. Phase-to-phase with the circuit breaker on (circuit breaker contacts closed).
  - c. Between each line and load terminal with the circuit breaker off (circuit breaker contacts open).
4. Record resistance values. Resistance values of less than one megohm (1,000,000 ohm) should be investigated.

## Thermal-Magnetic Circuit Breaker Performance Tests

### DANGER

#### HAZARD OF ELECTRIC SHOCK, EXPLOSION, OR ARC FLASH

- Apply appropriate personal protective equipment (PPE) and follow safe electrical work practices. See NFPA 70E or CSA Z462.
- This equipment must be installed and serviced by qualified electrical personnel.
- Turn off all power supplying this equipment before working on or inside equipment.
- Always use a properly rated voltage sensing device to confirm power is off.
- Replace all devices, doors and covers before turning on power to this equipment.

**Failure to follow these instructions will result in death or serious injury.**

## Inverse-Time Overcurrent Trip Test

1. Completely de-energize and remove the circuit breaker from service. Conduct the following tests at 300% of the circuit breaker ampere rating to verify the performance of the thermal tripping element on thermal-magnetic circuit breakers using a high-current, low-voltage ac power supply of less than 24 V.
2. Test in open air at 25°C (77°F) ambient temperature.
3. Trip times are measured from a “cold start.” A cold start, as defined by Underwriters Laboratories Inc. Standard 489 occurs at 25°C ± 3° (77°F ± 5°). Therefore, before beginning overcurrent testing, the circuit breaker must be in 25°C (77°F) ambient temperature long enough for all parts to reach that temperature. Circuit breakers that have been in higher ambient temperatures may take two to four hours to reach the steady state temperatures mentioned above.
4. Connect the circuit breaker to a power supply by using a minimum of four feet (1.2 m) of cable on each connection. Size the cable according to the ampere rating of the tested circuit breaker. Refer to the National Electrical Code Table 310-16; use the 75°C column for proper conductor sizing. Improperly sized cable will affect test results.
5. Test each pole of the circuit breaker individually at 300% of rated current using a high-current, low-voltage ac power supply.

**Table 2: Inverse-Time Overcurrent Trip Test<sup>1</sup>**

Rated Continuous Current	Maximum Trip Time	
	240 V	480 V / 600V
0–30 A	60 sec.	
31–50 A	80 sec.	100 sec.
51–100 A	140 sec.	160 sec.
101–150 A	200 sec.	250 sec.
151–225 A	230 sec.	275 sec.
226–400 A	300 sec.	350 sec.
401–600 A		450 sec.
601–800 A		500 sec.
801–1000 A		600 sec.
1001–1200 A		700 sec.
1201–1600 A		775 sec.
1601–2000 A		800 sec.
2001–2500 A		850 sec.
2501–5000 A		900 sec.

<sup>1</sup> For thermal-magnetic circuit breakers (at 300% of circuit breaker ampere rating). Derived from table 5-3, NEMA Standard AB 4-1996.

- Record and compare the trip test values to those in Table 2. As long as the recorded trip times are below the maximum trip times, the circuit breaker is providing acceptable thermal protection.

If verification of the manufacturer’s data is required, compare the trip times to the 300% trip range shown on the trip curve for the specific circuit breaker. If field test results fall outside the characteristic trip curve tolerance band, the test conditions and methods should be carefully evaluated for accuracy. A small error in test current results in a large error in trip time.

**Instantaneous (Magnetic) Trip Test**

This test simulates short-circuit conditions using a low-voltage test supply. To keep stray magnetic fields from affecting test results, test cables exiting the circuit breaker must be parallel with the current path of the circuit breaker for a minimum of 10 in (254 mm). Test results can also be influenced by the wave shape of the supply current. Use a power source with true sinusoidal output and a true RMS or analog ammeter to ensure accurate results. To verify the performance of the instantaneous (magnetic) trip element, proceed as follows:

**NOTE:** Test PA and PH circuit breakers with the circuit breaker mounted on a terminal pad kit (catalog number PALTB). PC circuit breakers should be tested with the circuit breaker mounted on the terminal pad kit provided with the circuit breaker.

Test NA and NC circuit breakers in the end-use equipment or lying flat on a piece of 1/8 in. (3 mm) thick steel.

- Set the circuit breaker instantaneous (magnetic) trip adjustment, if provided, to the high setting. Tests conducted at the high setting ensure instantaneous trip protection exists at all lower settings.
- Connect the circuit breaker to the low-voltage test source with any convenient length of conductor.
- Test each pole individually by the pulse method as follows:

The pulse method requires that the test equipment have a controlled closing and a pointer-stop ammeter, a calibrated image-retaining oscilloscope, or a high-speed, sampling-rate digital ammeter. The pulse method involves the following steps:

- Connect one pole of the test circuit breaker to the test equipment.
- Set the current control of the test equipment to a value approximately 70% of the instantaneous trip current setting.  
Example: If the instantaneous (magnetic) trip setting is 2000 A, set the test equipment to 1400 A.
- After the circuit breaker is properly connected and adjusted, apply current in approximately 10-cycle pulses.
- Starting at 70% of the instantaneous trip setting, increase the current of each pulse until the circuit breaker trips. After each pulse, move the circuit breaker handle to the full reset position and then to the on position.
- Repeat step D to recheck and verify this value. Start with the current level below the value measured in step D to ensure a “no trip” on the initial pulse.

- Record current level and trip time. To ensure protection of the rated conductor, the current necessary to trip the circuit breaker instantaneously must not exceed 140% of the high setting for circuit breakers 250 A frame size and below, and 125% of the high setting for circuit breakers 400 A frame size and above. These settings are printed

on the faceplate label of the circuit breaker. If currents higher than these maximum levels are necessary to trip the circuit breaker, consult your local field sales office.

If field test results fall outside the characteristic trip curve tolerance band, the test conditions and methods must be carefully evaluated for accuracy.

#### **Rated Current Hold-In Test**

This test should be performed only on circuit breakers that have been nuisance tripping under normal conditions.

Conduct the test in a 25°C (77°F) ambient temperature using a high-current, low-voltage ac power supply. Follow the same procedure used in the Inverse-time Overcurrent Trip Test, steps 1-3, page 14. Connect all poles of the circuit breaker in series using cables with the appropriate ampacity for the application. These cables should be 4 ft. (1.22 m) long per terminal (8 ft. [2.43 m] total between poles). All connectors must be properly torqued according to the circuit breaker label specifications.

The circuit breaker should not trip when 100% of the device's rated current is applied for one hour for circuit breakers rated less than 100 A, or two hours for circuit breakers rated more than 100 A. If the circuit breaker trips, reset and move the handle from the off to on position several times while under load, then repeat the test. If the tripping condition continues, contact your local field sales office.

#### **Contact Resistance Test**

Circuit breaker pole resistance tests are not reliable indicators of circuit breaker performance because the resistance values are influenced by a number of transient factors including contact surface oxidation, foreign material between the contacts, and testing methods. NEMA AB 4 paragraph 6.4.1 states: "The millivolt drop of a circuit breaker pole can vary significantly due to inherent variability in the extreme low resistance of the electrical contacts and connectors. Such variations do not necessarily predict unacceptable performance and shall not be used as the sole criteria for determination of acceptability."

High pole resistance may also be caused by eroded contacts, low contact force, and loose termination. The only one of these factors likely to be present on a new circuit breaker is a loose termination, since the contacts are new and there has been no opportunity for contact pressure to have drifted from the factory setting. A loose termination can be corrected in the field.

If a contact resistance test is done, it is important to do it after the contacts have been conditioned by instantaneous primary injection testing to ensure the contacts are clear of resistive films, oxidation and foreign material. If the circuit breaker has been in service with no performance issues, (overheating or nuisance tripping), contact resistance measurements are redundant and of little value.

Square D recommends that a DLRO (Digital Low Resistance Ohmmeter) be used, using a 10 A dc test current for circuit breaker ratings below 100 A, and using 100 A dc for circuit breakers rated 100 A and above. The median (middle) value of three readings (toggling the circuit breaker between each reading) should be recorded for each pole tested. If this value is equal to or less than the value listed in Table 3, the pole is acceptable. If the reading is higher, the cause should be investigated and corrected if possible. Contact your local field office for more information.

**Table 3: Maximum Micro-Ohms Per Pole**

Circuit Breaker		Micro-Ohms	Circuit Breaker		Micro-Ohms	Circuit Breaker		Micro-Ohms	Circuit Breaker		Micro-Ohms
Type	Rating	(u ohm)	Type	Rating	(u ohm)	Type	Rating	(u ohm)	Type	Rating	(u ohm)
FA, FH, FC	15	38,400	KA, KH	70	3,420	MA, MH	125	1,970	LD, LG, LJ, LL, LR	250	630
	20	23,100		80	2,620		175	1,120		400	240
	25	14,800		90	2,390		200	890		600	160
	30	10,400		100	1,930		225	730	NSF, CG, CJ	16	35,000
	35	7,860		110	1,620		250	600		25	14,000
	40	6,010		125	1,250		300	425		32	7,000
	45	5,180		150	890		350	322		40	6,000
	50	4,190		175	680		400	246		50	4,000
	60	2,910		200	540		500	180		63	2,800
	70	2,340		225	430		600	140		80	1,700
80	1,790	250	350	700	115	100	1,100				
90	1,430	KC, KI	110	1,620	800	96	NSJ	400	240		
100	1,160		125	1,250	900	83		600	140		
FD, FG, FJ	15		34,700	150	890	1000	67	MG, MJ	300	780	
	20	19,500	175	680	15	35,000	350		570		
	25	12,500	200	540	20	23,000	400		440		
	30	9,550	225	430	25	14,000	450		350		
	35	7,020	250	350	30	10,400	500		280		
	40	6,800	LA, LH	125	1,500	35	7,860		600	190	
	45	5,780		150	1,200	40	6,010		700	140	
	50	5,000		175	980	45	5,180		800	110	
	60	4,120		200	770	50	4,190		600	138	
	70	3,510		225	610	60	2,910		700	131	
80	3,170	250		510	70	2,340	800	105			
90	2,510	300		480	80	1,790	900	100			
100	2,260	350		330	90	1,430	1000	82			
110	2,060	400		310	100	1,200	1200	69			
125	1,800	LI, LC		300	589	110	1,160	NA, NC	600	132	
20	26,200		350	513	125	1,100	700		123		
25	17,700		400	308	150	1,020	800		100		
30	12,300		450	310	150	890	1000		77		
35	9,070		500	286	175	680	1200		66		
40	7,330		600	209	200	600	1400		61		
45	5,790		JD, JG, JJ, JL, JR			225	525		PA, PH, PC	1600	50
50	4,930					250	450			1800	43
60	3,420					NSF, CG, CJ	16			35,000	
70	3,020										
80	2,310										
90	1,980										
100	1,600										

**Remove Test Connections**

Upon completing testing:

- Remove test connections from circuit breaker.
- Inspect connections for damage caused by testing.

**Additional Information**

For more information concerning Square D circuit breakers, refer to the appropriate instruction manual. These manuals contain installation instructions, mounting information, safety features, wiring diagrams, and troubleshooting charts for specific circuit breakers.

## Section 4—Performance Tests for PowerPact™ Circuit Breakers

### Performance Tests

#### **⚠ DANGER**

##### **HAZARD OF ELECTRIC SHOCK, EXPLOSION, OR ARC FLASH**

- Apply appropriate personal protective equipment (PPE) and follow safe electrical work practices. See NFPA 70E or CSA Z462.
- This equipment must be installed and serviced by qualified electrical personnel.
- Turn off all power supplying this equipment before working on or inside equipment.
- Always use a properly rated voltage sensing device to confirm power is off.
- Replace all devices, doors and covers before turning on power to this equipment.
- Do not touch the circuit breaker terminals or the test leads while the circuit breaker is being tested.

**Failure to follow these instructions will result in death or serious injury.**

### Insulation Resistance Test (Dielectric Testing)

#### **NOTICE**

##### **HAZARD OF EQUIPMENT DAMAGE**

- Insulation resistance testing (dielectric tests) may damage Micrologic™ 5.0/6.0P or 5.0/6.0H trip units.
- Remove rating plug from trip unit prior to testing.
- Replace trip unit if rating plug was not removed during tests or if trip unit was exposed to more than 700 Vac.

**Failure to follow these instructions can result in equipment damage.**

These tests check the performance of PowerPact™ electronic trip circuit breakers.

Do the performance tests in the order given to maximize the accuracy of the test results.

**NOTE:** Never do the contact resistance test before doing the instantaneous primary injection testing. The primary injection testing will ensure the contacts are clear of resistive films, oxidation and foreign material.

The following tests are intended to verify that a circuit breaker is operating properly. Precisely controlled factory testing conditions are used to establish the characteristic trip curves. If field test results fall outside the characteristic trip curve tolerance band, carefully evaluate the test conditions and methods for accuracy.

When questionable conditions or results are observed during inspection and performance tests, consult your local field sales office. Circuit breakers with accessories or factory modifications may require special investigation. If it is necessary to return a circuit breaker to the manufacturing facility, use proper packaging and packing materials to avoid shipping damage.

Severe environmental conditions can reduce the dielectric strength of molded case circuit breakers. Check insulation resistance during electrical system testing. To check the insulation resistance, perform the following steps:

1. De-energize and isolate the circuit breaker.
2. Clean the circuit breaker as described earlier.
3. Using a megohmmeter with a capacity of 500 -1000 Vdc, apply voltage from: a. Each phase-to-ground with the circuit breaker on (circuit breaker contacts closed). b. Phase-to-phase with the circuit breaker on (circuit breaker contacts closed). c. Between each line and load terminal with the circuit breaker off (circuit breaker contacts open).
4. Record resistance values. Resistance values of less than one megohm (1,000,000 ohm) should be investigated.

**NOTE:** 5.2E 5.3E, 6.2E, 6.3E Micrologic trip units have some normal leakage due to internal circuits for metering. When testing systems with more than 10 circuit breakers with these trip units, it may be necessary to open some of the circuit breakers at a time to make sure all breakers and equipment is sound and insulation resistance is within acceptable limits.

## Micrologic™ Trip Unit Checks

Circuit breakers with Micrologic™ trip units can have their trip unit operation tested with secondary injection testing using the one of the available test kits. (See Section 6 for available test kits by circuit breaker.)

Secondary injection testing does not test the current transformers and connections. Primary injection testing can be used to ensure that all trip system connections have been correctly made.

If the circuit breaker is tested by the primary injection method, the Powerlogic™ system can remain connected to the circuit breaker during testing without affecting the results.

**NOTE:** Testing a circuit breaker connected to a Powerlogic system causes the Powerlogic system to react as if the circuit breaker were experiencing the actual faults.

## Procedure to Defeat Zone-Selective Interlocking

Zone-selective interlocking (ZSI) is a method of communication between electronic-trip overcurrent protective devices. ZSI allows interlocked devices at different levels to work together as a system in which a short circuit or ground fault is isolated and cleared with minimum time delay. The purpose of defeating ZSI is to verify the characteristics of the specific circuit breaker short-time and ground-fault trip delay functions.

## Secondary Injection

Field installation of a trip unit requires secondary injection testing with a Full-Function Test Kit for PowerPact P- and R-frame circuit breakers and a UTA for PowerPact H-, J-, and L-frame circuit breakers. This will ensure that the newly-installed trip unit is functioning properly. The test will require opening and closing the circuit breaker. Follow the procedures outlined in the instruction bulletins shipped with the circuit breaker and the Full-function Test Kit.

1. Make sure the circuit breaker is isolated from all upstream and downstream devices.
2. Perform secondary injection testing as outlined in the instruction bulletin shipped with the full-function test kit or UTA. Verify that all applicable trip unit functions are operating properly.
3. Repeat step 2 with the circuit breaker in the open position.

**NOTE:** The test kit states that the circuit breaker should be closed when performing the test. Do not close the circuit breaker for this step.

4. If any test fails, do not put the circuit breaker into service and contact the local sales office for factory authorization service.

## Primary Injection Testing

Primary injection testing can be used to ensure that all trip system connections have been correctly made.

**NOTE:** Secondary injection testing continues to be the Schneider Electric preferred method for testing circuit breakers. Improper primary injection testing can cause damage to the circuit breakers. Failure to conduct primary injection testing in the proper manner could result in circuit breakers passing testing, while ultimately damaging the integrity of the circuit breaker long term.

## NOTICE

### HAZARD OF EQUIPMENT DAMAGE

Make connection to the circuit breaker carefully using rated cable and appropriate connection methods. Do not use clamps or other methods that can score or otherwise damage the finish of the connectors.

**Failure to follow these instructions can result in equipment damage.**

1. If performing primary injection testing on fixed circuit breakers, connect circuit breaker to power supply using rated cable and appropriate connection method.
2. Record each of the original trip unit switch settings. (Settings must be reset after testing is complete.)
3. Set the long-time pickup ( $I_r$ ) switch (A) to the minimum setting.

Figure 1: Long-Time Pickup ( $I_r$ )

### PowerPact P- and R-Frame

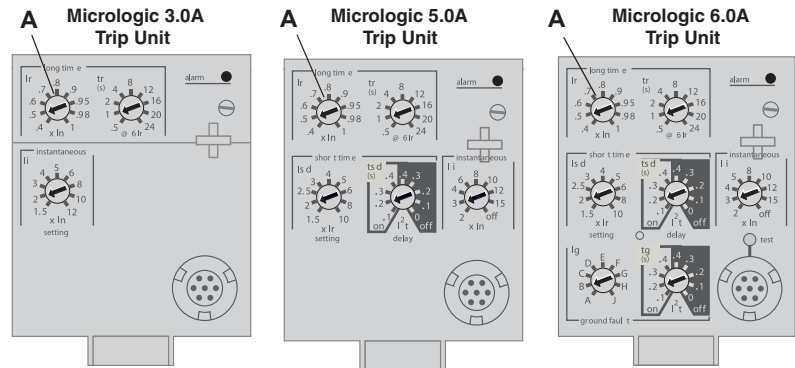

### PowerPact H-, J- and L-Frame

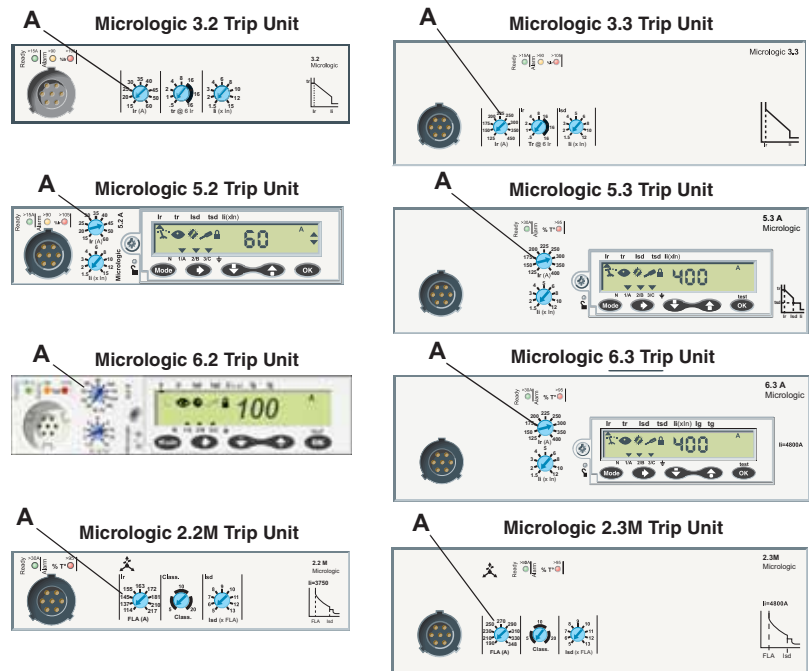

- a. For ground-fault and/or zone-selective interlocked trip units, use the test kit to inhibit ground-fault and zone-selective interlocking functions.
- b. If an auxiliary power supply is being used for the Micrologic trip unit, disconnect the auxiliary power supply.
- c. Find the primary injection current needed by multiplying the long-time pickup current (long-time pickup setting  $I_r$  x sensor plug  $I_n$  x 125% (i.e.  $I_r \times I_n \times 1.25$ ).

- d. Inject primary current into A-phase and monitor the overload indicator light. Verify that the overload indicator light (A) lights between 105% and 120% of the  $I_r \times I_n$  value.

**NOTE:** On H-, J-, and L-frame circuit breakers LED:

The green “Ready” LED (B) blinks slowly when the electronic trip unit is ready to provide protection. It indicates the trip unit is operating correctly.

Orange overload pre-alarm LED (C): steady on when  $I > 90\%$   $I_r$

Red overload LED (A): steady on when  $I > 105\%$   $I_r$

- e. Repeat for all phases and neutral (if applicable).
- f. If overload indicator light does not light correctly, check all trip unit connections and test setup. If unit still fails primary injection testing, contact the local sales office.

**Figure 2: Overload Indicator Light**

**PowerPact P- and R-Frame**

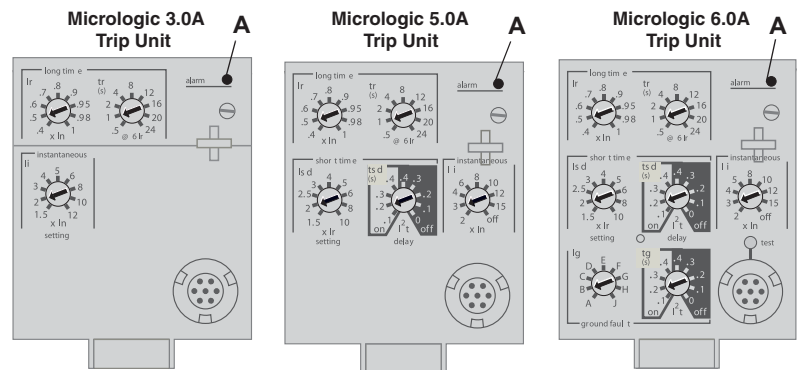

**PowerPact H-, J- and L-Frame**

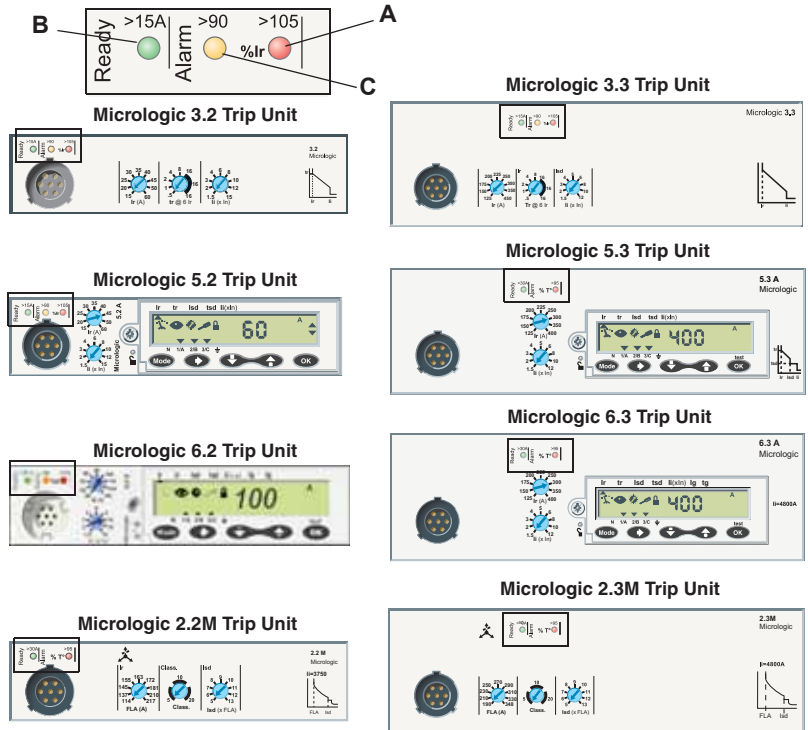

## Circuit Breakers with Integral Ground Fault Protection

### Ground-Fault Protection and Indication Only Tests for Radial Systems

#### **⚠ DANGER**

##### **HAZARD OF ELECTRIC SHOCK, EXPLOSION, OR ARC FLASH**

- Apply appropriate personal protective equipment (PPE) and follow safe electrical work practices. See NFPA 70E or CSA Z462.
- This equipment must be installed and serviced by qualified electrical personnel.
- Turn off all power supplying this equipment before working on or inside equipment.
- Always use a properly rated voltage sensing device to confirm power is off.
- Replace all devices, doors and covers before turning on power to this equipment.

**Failure to follow these instructions will result in death or serious injury.**

Micrologic™ electronic-trip circuit breakers with the integral ground-fault protection function require special attention when testing overload and short-circuit functions. The single-pole primary injection tests for the inverse-time overcurrent, short-time and instantaneous functions will cause ground-fault trips due to the return current path not going through the circuit breaker. To overcome this difficulty, use the Hand-Held, Full-Function, or UTA Test Kit to defeat the ground-fault function on PowerPact circuit breakers equipped with Micrologic trip units.

### Ground-Fault Trip Test

The ground-fault function of a Micrologic™ electronic-trip circuit breaker provides ground-fault protection for equipment with adjustable pickup and delay values. The ground-fault delay feature determines how long the circuit breaker waits before initiating a trip signal during a ground fault. Performance of the ground-fault functions of the circuit breaker can be tested using a high-current, low-voltage ac power supply.

#### Test Procedure

1. Completely de-energize and remove the circuit breaker from service.
2. Before testing, record pickup and delay setting for all functions. Reset the trip unit to these same settings after the test procedure is completed.
3. If testing a circuit breaker that is equipped with zone-selective interlocking, follow the procedure to defeat zone-selective interlocking on page 19. If you are using a secondary injection test kit for these tests, carefully read and follow the test kit instructions about zone-selective interlocking.

**NOTE:** Failure to defeat zone-selective interlocking will result in trip time inaccuracy.

4. Use these settings for the test:

Long-time Pickup/Ampere Rating = Max.

Long-time/Overload Delay = Max

Short-time/Short-circuit Delay = Max. ( $I^2t$  IN or ON)

Instantaneous = Max.

Ground-fault Pickup = Min.

Ground-fault Delay = 0.2

5. Follow the hookup procedure appropriate to the test application.  
For circuit breakers without a neutral current transformer, go to step 8.  
For circuit breakers with the integral ground-fault function in a three-phase, four-wire system, an externally-mounted neutral current transformer (CT) must be used. The neutral CT is connected to the circuit breaker by a shielded cable (14 AWG [2.1 mm<sup>2</sup>] wire is recommended).

**NOTE:** When testing, disconnect or turn off 24 Vdc control power to F1 and F2, if equipped and disconnect the Hand-Held or Full-Function Test Kit from the trip unit, if connected.

**Figure 3: Test Hookup Diagram for Neutral CT Phasing Test**

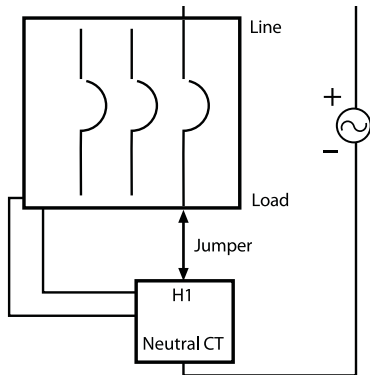

See circuit breaker instructions bulletin for connections to circuit breaker and neutral CT.

**Figure 4: Test Hookup Diagram for Neutral CT Size Test**

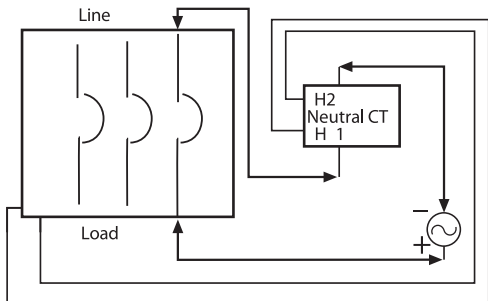

See circuit breaker instructions bulletin for connections to circuit breaker and neutral CT.

**Figure 5: Test Hookup Diagram for Circuit Breaker Without Neutral CT**

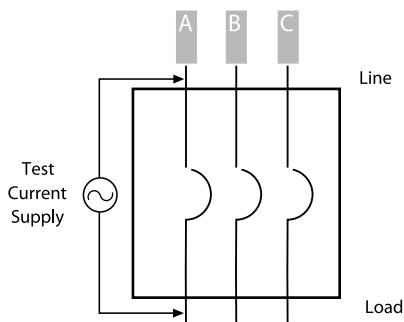

6. Verify correct phasing of the neutral CT (three-phase, four-wire systems) by performing a No Trip Test as follows:

- a. Connect the circuit breaker and neutral CT as shown in Figure 3. The jumper must go from the load connection on the circuit breaker to the H1 connection on the neutral CT (or the side of the neutral CT that has the red dot). Connect the secondary of the neutral CT according to the circuit breaker instruction manual or the neutral CT instructions.
- b. Apply current above the ground-fault pickup level and maintain longer than the ground-fault delay.
- c. The circuit breaker must not trip. No trip indicates that both the phase CT and neutral CT are phased properly.

7. Verify the correct size of the neutral CT (three-phase, four-wire systems) by performing a Trip Test as follows:

- a. Connect the circuit breaker and neutral CT as shown in Figure 4. Connect the polarity (+) terminal of the high current injection unit to the load side of the circuit breaker. The jumper must go from the line connection on the circuit breaker to the H1 connection on the neutral CT (or the side of the neutral CT that has the red dot). Connect the non-polarity (-) terminal of the high current injection unit to H2 on the neutral CT (on the line side of the circuit breaker). Connect the secondary of the neutral CT according to the circuit breaker instruction manual or the neutral CT instructions.
- b. Apply current.
- c. The circuit breaker must trip at half the value of the ground-fault pickup. Tripping indicates that both the phase CT and neutral CT have the same turns ratio (same size).

8. Test ground fault pickup and delay by performing a trip test as follows:

- a. Connect the circuit breaker as shown in Figure 5, (three-phase, three-wire systems) or Figure 6 (three-phase, four-wire systems).

**NOTE:** The recommended method of testing ground-fault pickup and delay is the “pulse” method. This method will be the most accurate, but requires that the test equipment have a calibrated image-retaining oscilloscope or high-speed sampling rate digital ammeter. An accurate timer is needed to monitor delay time.

- b. After the circuit is properly connected and closed, apply current in short pulses of 10-cycle duration. Starting at 70% of the expected trip value, increase the current on each succeeding pulse until the circuit breaker trips.

**Figure 6: Test Hookup Diagram for Ground-Fault Pickup and Delay Test**

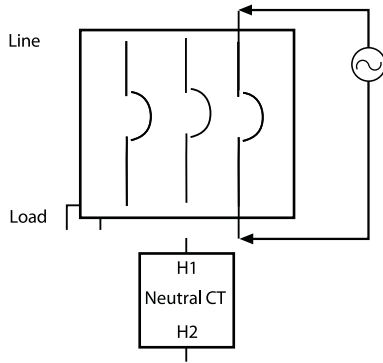

- c. Reclose the circuit breaker and reduce the current level; pulse again to determine if the pickup level found was overshoot.
- d. Repeat steps b and c to further isolate the pickup point.
- e. To determine delay time, test each pole of the circuit breaker individually at 150% of the ground-fault pickup setting. Monitor the time from this pickup point until the circuit breaker trips to obtain the delay time.
- f. Record pickup and delay values and compare the results to the trip curve.

The ground-fault test can also be done using secondary injection testing using the Full-Function Test Kit. Secondary injection testing does not test the current transformers and connections.

**Table 4: Maximum Micro-Ohms Per Pole**

PowerPact Type	Rating	Micro-Ohms (u ohm)
HD, HG, HJ, HL, HR	60	1,500
	100	1200
	150	600
JD, JG, JJ, JL, JR	250	450
	250	630
LD, LG, LJ, LL, LR	400	240
	600	160
	600	160
DG, DJ, DL	400	240
	600	140
PG, PJ, PK, PL	250	488
	400	200
	600	114
	800	78
	1000	55
RG, RJ, RK, RL	1200	39
	600	106
	800	81
	1000	63
	1200	53
	2000	38
2500	33	

**Contact Resistance Test**

Circuit breaker pole resistance tests are not reliable indicators of circuit breaker performance because the resistance values are influenced by a number of transient factors including contact surface oxidation, foreign material between the contacts, and testing methods. NEMA AB 4 paragraph 6.4.1 states: “The millivolt drop of a circuit breaker pole can vary significantly due to inherent variability in the extreme low resistance of the electrical contacts and connectors. Such variations do not necessarily predict unacceptable performance and shall not be used as the sole criteria for determination of acceptability.”

High pole resistance may also be caused by eroded contacts, low contact force, and loose termination. The only one of these factors likely to be present on a new circuit breaker is a loose termination, since the contacts are new and there has been no opportunity for contact pressure to have drifted from the factory setting. A loose termination can be corrected in the field.

If a contact resistance test is done, it is important to do it after the contacts have been conditioned by instantaneous primary injection testing to ensure the contacts are clear of resistive films, oxidation and foreign material. If the circuit breaker has been in service with no performance issues, (overheating or nuisance tripping), contact resistance measurements are redundant and of little value.

Square D recommends that a DLRO (Digital Low Resistance Ohmmeter) be used, using a 10 A dc test current for circuit breaker ratings below 100 A, and using 100 A dc for circuit breakers rated 100 A and above. the median (middle) value of three readings (toggling the circuit breaker between each reading) should be recorded for each pole tested. If this value is equal to or less than the value listed in Table 4, the pole is acceptable. If the reading is higher, the cause should be investigated and corrected if possible. Contact your local field office for more information.

**Remove Test Connections**

Upon completing testing:

- Remove test connections from circuit breaker.
- Inspect connections for damage caused by testing.
- Reset the long-time pickup switch to original settings, as recorded in above.
- If an auxiliary power supply is being used for the Micrologic trip unit, reconnect the auxiliary power supply.

## Additional Information

For more information concerning Square D Circuit breakers, refer to the appropriate instruction manual. These manuals contain installation instructions, mounting information, safety features, wiring diagrams, and troubleshooting charts for specific circuit breakers.

## Section 5—Performance Tests for Electronic Trip Legacy LE/LX, ME/MX, PE/PX, and SE Circuit Breaker

### General Circuit Breaker Performance Tests

#### **⚠ DANGER**

##### **HAZARD OF ELECTRIC SHOCK, EXPLOSION, OR ARC FLASH**

- Apply appropriate personal protective equipment (PPE) and follow safe electrical work practices. See NFPA 70E or CSA Z462.
- This equipment must be installed and serviced by qualified electrical personnel.
- Turn off all power supplying this equipment before working on or inside equipment.
- Always use a properly rated voltage sensing device to confirm power is off.
- Replace all devices, doors and covers before turning on power to this equipment.
- Do not touch the circuit breaker terminals or the test leads while the circuit breaker is being tested.

**Failure to follow these instructions will result in death or serious injury.**

#### **NOTICE**

##### **HAZARD OF EQUIPMENT DAMAGE**

Do not apply test voltage to control circuits or accessory terminals; damage to electronic and/or low-voltage components can result.

**Failure to follow these instructions will result in equipment damage.**

Do the performance tests in the order given to maximize the accuracy of the test results.

**NOTE:** Never do the contact resistance test before doing the instantaneous primary injection testing. The primary injection testing will ensure the contacts are clear of resistive films, oxidation and foreign material.

The following tests are intended to verify that a circuit breaker is operating properly. Precisely controlled factory testing conditions are used to establish the characteristic trip curves. If field test results fall outside the characteristic trip curve tolerance band, carefully evaluate the test conditions and methods for accuracy.

When questionable conditions or results are observed during inspection and performance tests, consult your local field sales office. Circuit breakers with accessories or factory modifications may require special investigation. If it is necessary to return a circuit breaker to the manufacturing facility, use proper packaging and packing materials to avoid shipping damage. Repacking instructions are contained in the circuit breaker instruction manual.

#### **Insulation Resistance Test**

Severe environmental conditions can reduce the dielectric strength of molded case circuit breakers. Check insulation resistance during electrical system testing.

To check the insulation resistance, perform the following steps:

1. De-energize the isolate the circuit breaker:
2. Clean the circuit breaker as described earlier.
3. Using a megohmmeter with a capacity of 500–1000 Vdc, apply voltage from:
  - a. Each phase-to-ground with the circuit breaker on (circuit breaker contacts closed).
  - b. Phase-to-phase with the circuit breaker on (circuit breaker contacts closed).
  - c. Between each line and load terminal with the circuit breaker off (circuit breaker contacts open).
4. Record resistance values. Resistance values of less than one megohm (1,000,000 ohm) should be investigated.

## Micrologic™ Electronic-Trip Circuit Breaker Tests

### NOTICE

#### HAZARD OF EQUIPMENT DAMAGE

- Circuit breakers are heavy and can be damaged with improper handling. Use care when handling and transporting circuit breaker to test equipment.
- Make connection to the circuit breaker carefully using rated cable and appropriate connection methods. Do not use clamps or other methods that can score or otherwise damage the finish of the connectors.

**Failure to follow these instructions can result in equipment damage.**

#### Long-time Trip Test

The long-time ampere rating defines the maximum level of current the circuit breaker will carry continuously. Micrologic™ electronic-trip circuit breakers pick up and begin timing when a phase current exceeds  $110\% \pm 10\%$  of the ampere rating. The long-time delay feature permits variations of the circuit breaker inverse-time delay characteristic. This delay determines how long the circuit breaker will carry a sustained overcurrent before initiating a trip signal. Performance of the inverse-time overcurrent functions of the circuit breaker can be tested using a high-current, low-voltage ac power supply.

1. Completely de-energize and remove the circuit breaker from service.
2. Before testing, record pickup and delay settings for all functions. Important: reset the trip unit to these same settings after the test procedure is completed.
3. If the Micrologic circuit breaker has the integral ground-fault protection function, see test procedures for circuit breakers with integral ground fault, page 29, before continuing with the test procedure.
4. Use the following settings for the test:  
Long-time/Ampere Rating = Max  
Long-time/Overload Delay = Min.  
Short-time/Short Circuit = Max.  
Short-time/Short Circuit Delay = Max. ( $I^2t$  IN or ON)  
Instantaneous = Max.

**NOTE:** Labeling and trip unit functions are specified by the circuit breaker series and catalog numbers. Series and catalog numbers are printed on the circuit breaker.

5. Connect the circuit breaker to a high-current, low-voltage ac power supply. Connect the circuit breaker to the test power source with any convenient length of adequately sized wiring.
6. Test all phases of the circuit breaker individually, or in pairs, for integral ground-fault equipped circuit breakers as required in the special test procedure on page 29.
7. Use the slow “run-up” test method to determine the pickup level. Slowly increase the current until the long-time pickup light glows steadily; this is defined as the pickup level.

**NOTE:** All Micrologic electronic-trip circuit breakers are equipped with Long-time/Overload Memory or thermal imaging. The Long-time/Overload Memory can be reset by using the appropriate memory reset module. See the local field sales office for additional information of the memory reset modules and test kits. If the memory-reset module is not used, wait at least 15 minutes to allow the memory to clear and reset before proceeding with the tests.

8. To determine the delay time, set the current to 300% of the ampere rating value. Monitor the time from this pickup point until the circuit breaker trips; this is the delay time.
9. Record pickup and delay values and compare them to the appropriate trip curve.

The long-time trip test can also be done using the UTS-3 secondary injection test kit. These secondary injection test sets do not test the current transformers and connections.

### Short-Time Trip Test

The short-time pickup characteristic of a Micrologic electronic-trip circuit breaker adjusts the level of current at which the short-time delay begins timing. Short-time pickup levels are multiples of sensor size times the rating plug multiplier. The short-time delay function determines how long the circuit breaker will wait before initiating a trip signal during a short circuit.

Performance of the short-time functions of the circuit breaker can be tested using a high-current, low-voltage ac power supply.

1. If testing a circuit breaker that is equipped with zone-selective interlocking, follow the Procedure to Defeat Zone-Selective Interlocking on page 30. If you are using a secondary injection test kit for these tests, carefully read and follow the test kit instructions about zone-selective interlocking.

**NOTE:** Failure to defeat zone-selective interlocking will result in tripping with no intentional delay.

2. If the Micrologic trip unit is equipped with the integral ground-fault protection function, see test procedures for circuit breaker with integral ground-fault, page 29, before continuing.
3. SE drawout circuit breakers with the integral ground-fault protection function require an adapter plug (catalog number SEPITK2) when completely removed from the cradle. The adapter plug makes the necessary jumper connections on the secondary circuit. These jumper connections are normally made when the circuit breaker is in the connected position. Follow the instructions provided with the plug to ensure proper application.

4. Use the following settings for the test:

Long-time Pickup/Ampere Rating - Max.

Long-time/Overload Delay = Max.

Short-time/Short-circuit Pickup = Min.

Short-time/Short-circuit Delay = Min.

Instantaneous = Max.

**NOTE:** For LE Series 1B, ME Series 3, 4, 5, 5A, 5B, NE Series 1, 2, 3, 3A, 3B, PE Series 4, 5, 6, 6A, 6B, and SE Series 2, 3, 3A, 3B trip units, the Min. Short-time/Short-circuit setting will be 0.1 I<sub>2t</sub> OUT.

5. Connect the circuit breaker to the test source with any convenient length of conductor.
6. For non-ground-fault circuit breakers, test all poles of the circuit breaker individually. For circuit breakers with integral ground-fault, test each pole of the circuit breaker as noted in the special test procedure on page 29.
7. Short-Time Pickup Test

After the circuit breaker is properly connected, inject the phase under test with a current value just below the minimum pickup value indicated by the trip curve. Test current duration must exceed expected delay time (determined from the trip curve). The circuit breaker should not trip.

Repeat the test using the maximum pickup value indicated by the trip curve. The circuit breaker should trip, indicating an acceptable pickup level. If the circuit breaker does not trip within the expected time, terminate the test to prevent thermal damage to the circuit breaker. If the precise pickup value is desired, repeat the test at current levels between the maximum and minimum. The lowest current value at which the circuit breaker trips is the pickup value.

#### 8. Short-Time Delay test

After the circuit breaker is properly connected, apply 150% of the nominal short-time pickup value. The circuit breaker should trip within the time limits defined by the trip curve. If the circuit breaker does not trip within the expected time limits, disengage the power supply to prevent thermal damage to the circuit breaker.

**NOTE:** All Micrologic electronic-trip circuit breakers are equipped with Long-Time/Overload Memory or thermal imaging. The overcurrent pulses used to test Short-time Pickup and Delay add to this memory. If the circuit breaker trips at a lower than expected current value after several overcurrent pulses, it may be tripping on the long-time function. The Long-time/Overload Memory can be reset using the appropriate memory reset module. If the memory reset module is not used, wait at least 15 minutes to allow the memory to clear and reset before proceeding with the tests.

The short-time trip test can also be done using the UTS-3 secondary injection test kit. These secondary injection test sets do not test the current transformers and connections.

#### Instantaneous Trip Test

The instantaneous trip function of a Micrologic electronic-trip circuit breaker determines the level of current at which the circuit breaker trips with no intentional delay. Performance of the instantaneous function of the circuit breaker can be tested using a high-current, low-voltage ac power supply.

1. If the Micrologic circuit breaker is equipped with the integral ground-fault protection function, see test procedures for circuit breaker with integral ground-fault, page 29, before continuing.
2. For non-ground-fault circuit breakers, test all poles of the circuit breaker individually. For circuit breakers with the integral ground-fault function, test each pole of the circuit breaker as noted in the special test procedure on page 29.
3. After the circuit breaker is properly connected and adjusted, apply current in approximately 10-cycle pulses. Start at 70% of the expected trip value, increase the current in each succeeding pulse until the circuit breaker trips.

**NOTE:** All Micrologic electronic-trip circuit breakers are equipped with Long-time/Overload Memory or thermal imaging. The overcurrent pulses used to test Short-time Pickup and Delay add to this memory. If the circuit breaker trips at a lower than expected current value after several Overcurrent pulses, it may be tripping on the long-time function. The Long-time/Overload Memory can be reset by using the appropriate memory reset module. If the memory reset module is not used, wait at least 15 minutes to allow the memory to clear and reset before proceeding with the tests.

4. Compare the pickup value to the trip curve for the tested circuit breaker. The instantaneous trip test can also be done using the UTS-3 secondary injection test kit. These secondary injection test sets do not test the current transformers and connections.

#### Circuit Breakers with Integral Ground Fault Protection

Micrologic electronic-trip circuit breakers with the integral ground-fault protection function require special attention when testing overload and short-circuit functions. The single-pole primary injection tests for the inverse-time overcurrent, short-time and instantaneous functions will cause ground-fault trips due to the return current path not going through the circuit breaker. To overcome this difficulty, use the looping method for Micrologic circuit breakers with the integral ground-fault feature.

**Figure 7: Special Overload and Short-circuit Test Procedures**

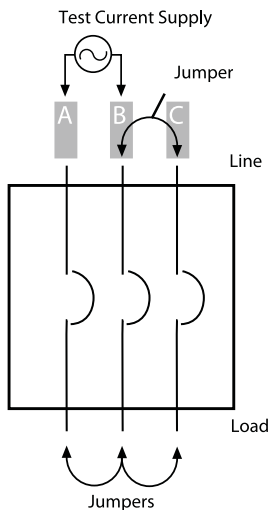

**Looping Method:**

Looping the current as shown in Figure 7, balances the amount of current entering and leaving the circuit breaker. This, in effect, eliminates ground-fault trips by keeping the internal ground-fault transformer balanced. Verification of successive poles can be made by varying the connections (loop AC, AB, BC).

**Exceptions:**

For SE fixed-type circuit breakers, connect terminals 16, 17, 18 and 19 together to defeat ground fault for test purposes. For SE drawout circuit breakers, use the adapter plug SEPITK2 to make the necessary connections.

**Procedure for Circuit Breakers Used with Powerlogic™ Systems**

LE, ME, NE, PE and SE circuit breakers connected to a Powerlogic™ system are connected via a communications adapter (catalog number CIM3F). If the circuit breaker is tested by the primary injection method, the Powerlogic system can remain connected to the circuit breaker during testing without affecting the results.

**NOTE:** Testing a circuit breaker connected to a Powerlogic system causes the Powerlogic system to react as if the circuit breaker were experiencing the actual faults.

When performing secondary injection testing using the UTS3 test set, the Powerlogic system must be disconnected from the circuit breaker. This is done by disconnecting the 4-pin plug connection on the adapter. The test set will indicate testing failed if the Powerlogic system is left connected when testing. After testing, reconnect the 4-pin plug to the adapter. Follow the instructions for the version of the Powerlogic software that is installed on the system to verify that communication has been re-established with the circuit breaker.

**Procedure to Defeat Zone-Selective Interlocking**

Zone-selective interlocking is a method of communication between electronic-trip overcurrent protective devices. Zone-selective interlocking allows interlocked devices at different levels to work together as a system in which a short circuit or ground fault is isolated and cleared with minimum time delay. The purpose of defeating zone-selective interlocking is to verify the characteristics of the specific circuit breaker short-time and ground-fault trip delay functions. This is accomplished by disconnecting restraint wiring and installing jumpers as required. This self-restrains the circuit breaker being tested. Label any restraint wires before disconnecting.

Table 5 outlines self-restraint (jumper) instructions for each of the Micrologic circuit breakers. Use wire size 14–18 AWG (1–2.1 mm).

**Table 5: Self-Restraint Settings**

Circuit Breaker Type/Trip Unit Series	Function (ST or GF)	Connect Terminal (Restraint IN)	To Terminal (Restraint OUT)
LE 1B	Short-time	#5	#6
LE 1B	Ground-fault	#7	#8
ME 3	Both	Violet wire	Violet wire
ME 4, 5, 5A, 5B	Short-time	#5	#6
ME 4, 5, 5A, 5B	Ground-fault	#7	#8
NE 1	Both	#6	#7
NE 2, 3, 3A, 3B	Short-time	#5	#6
NE 2, 3, 3A, 3B	Ground-fault	#7	#8
PE 4	Both	#6	#7
PE 5, 6, 6A, 6B	Short-time	#5	#6
PE 5, 6, 6A, 6B	Ground-fault	#7	#8
SE 2, 3, 3A, 3B (Fixed and Drawout)	Both	#23	#24
SE 2, 3, 3A, 3B (Fixed and Drawout)	Ground-fault	#20	#21
SE Drawout (Fully Removed From cradle)	Both	Use SEPTIK2 (see page 35)	Use SEPTIK2 (see page 35)

**NOTE:** If self-restraint jumpers are installed to defeat zone-selective interlocking for testing purposes, remove jumpers when testing is complete. Any restraint wires disconnected for the test should be reconnected at this time.

**Ground-Fault Protection and Indication Only Tests for Radial Systems**

**⚠ DANGER**

**HAZARD OF ELECTRIC SHOCK, EXPLOSION, OR ARC FLASH**

- Apply appropriate personal protective equipment (PPE) and follow safe electrical work practices. See NFPA 70E or CSA Z462.
- This equipment must be installed and serviced by qualified electrical personnel.
- Turn off all power supplying this equipment before working on or inside equipment.
- Always use a properly rated voltage sensing device to confirm power is off.
- Replace all devices, doors and covers before turning on power to this equipment.

**Failure to follow these instructions will result in death or serious injury.**

**Ground-Fault Trip Test**

The ground-fault function of a Micrologic electronic-trip circuit breaker provides ground-fault protection for equipment with adjustable pickup and delay values. The ground-fault delay feature determines how long the circuit breaker waits before initiating a trip signal during a ground fault. Performance of the ground-fault functions of the circuit breaker can be tested using a high-current, low-voltage ac power supply.

SE drawout circuit breakers with the integral ground-fault test feature require an adapter plug (Square D catalog number SEPITK2) when the circuit breaker is completely removed from the cradle. The adapter plug will make the necessary jumper connections on the secondary circuit. These jumpers are normally made when the circuit breaker is in the connected position. Follow the instructions provided with the adapter plug to ensure proper application.

**Test Procedure**

1. Completely de-energize and remove the circuit breaker from service.
2. Before testing, record pickup and delay setting for all function. Reset the trip unit to these same settings after the test procedure is completed.
3. If testing a circuit breaker that is equipped with zone-selective interlocking, follow the procedure to defeat zone-selective interlocking on page 30. If you are using a secondary injection test kit for these tests, carefully read and follow the test kit instructions about zone-selective interlocking.

**NOTE:** Failure to defeat zone-selective interlocking will result in trip time inaccuracy.

4. Use these settings for the test:
    - Long-Time Pickup/Ampere Rating = Max.
    - Long-Time/Overload Delay = Max
    - Short-Time/Short-Circuit Delay = Max. ( $I^2t$  IN or ON)
    - Instantaneous = Max.
    - Ground-Fault Pickup = Min.
    - Ground-Fault Delay = Min. ( $I^2t$  OUT of OFF)
- NOTE:** Do not use the INSTANT setting for ground-fault delay. On Series 2 SE circuit breakers, use ground-fault delay setting “2.”
5. Follow the hookup procedure appropriate to the test application.
    - For circuit breakers without a neutral current transformer, go to step 8.
    - For circuit breakers with the integral ground-fault function in a three-phase, four-wire system, an externally-mounted neutral current transformer (CT) must be used. The neutral CT is connected to the circuit breaker by a shielded cable (#14 AWG [2.5 mm] wire is recommended).

**Figure 8: Test Hookup Diagram for Neutral CT Phasing Test**

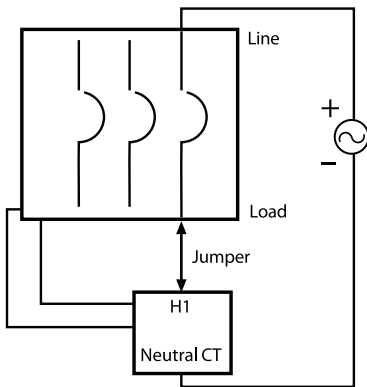

See circuit breaker instructions bulletin for connections to circuit breaker and neutral CT.

**Figure 9: Test Hookup Diagram for Neutral CT Size Test**

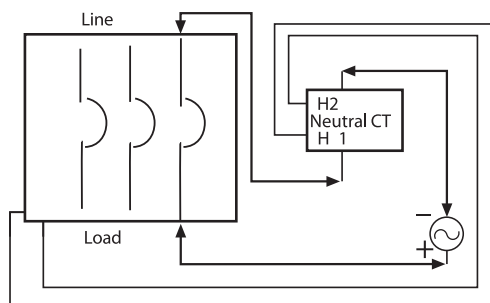

See circuit breaker instructions bulletin for connections to circuit breaker and neutral CT.

6. Verify correct phasing of the neutral CT (three-phase, four-wire systems) by performing a No Trip Test as follows:
  - a. Connect the circuit breaker and neutral CT as shown in Figure 8. The jumper must go from the load connection on the circuit breaker to the H1 connection on the neutral CT (or the side of the neutral CT that has the red dot). Connect the secondary of the neutral CT according to the circuit breaker instruction manual or the neutral CT instructions.
  - b. Apply current above the ground-fault pickup level and maintain longer than the ground-fault delay.
  - c. The circuit breaker must not trip. No trip indicates that both the phase CT and neutral CT are phased properly.
7. Verify the correct size of the neutral CT (three-phase, four-wire systems) by performing a Trip Test as follows:
  - a. Connect the circuit breaker and neutral CT as shown in Figure 9. Connect the polarity (+) terminal of the high current injection unit to the load side of the circuit breaker. The jumper must go from the line connection on the circuit breaker to the H1 connection on the neutral CT (or the side of the neutral CT that has the red dot). Connect the non-polarity (-) terminal of the high current injection unit to H2 on the neutral CT (on the line side of the circuit breaker). Connect the secondary of the neutral CT according to the circuit breaker instruction manual or the neutral CT instructions.
  - b. Apply current.
  - c. The circuit breaker must trip at half the value of the ground-fault pickup. Tripping indicates that both the phase CT and neutral CT have the same turns ratio (same size).

**Figure 10: Test Hookup Diagram for Circuit Breaker Without Neutral CT**

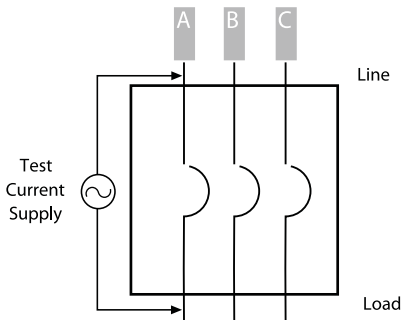

**Figure 11: Test Hookup Diagram for Ground-fault Pickup and Delay Test**

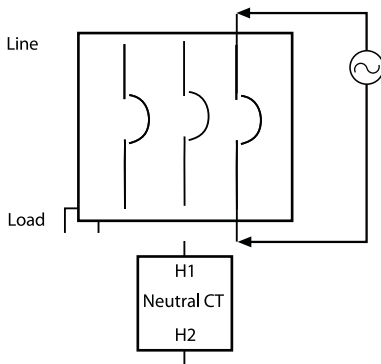

8. Test ground fault pickup and delay by performing a trip test as follows:
  - a. Connect the circuit breaker as shown in Figure 4, (three-phase, three-wire systems) or Figure 5 (three-phase, four-wire systems).
 

**NOTE:** The recommended method of testing ground-fault pickup and delay is the “pulse” method. This method will be the most accurate, but requires that the test equipment have a calibrated image-retaining oscilloscope or high-speed sampling rate digital ammeter. An accurate timer is needed to monitor delay time.
  - b. After the circuit is properly connected and closed, apply current in short pulses of 10-cycle duration. Starting at 70% of the expected trip value, increase the current on each succeeding pulse until the circuit breaker trips.
  - NOTE:** For Series 2 SE circuit breakers, current must be applied for a minimum of two seconds.
  - c. Reclose the circuit breaker and reduce the current level; pulse again to determine if the pickup level found was overshoot.
  - d. Repeat steps b and c to further isolate the pickup point.
  - e. To determine delay time, test each pole of the circuit breaker individually at 150% of the ground-fault pickup setting. Monitor the time from this pickup point until the circuit breaker trips to obtain the delay time.
  - f. Record pickup and delay values and compare the results to the trip curve.

The ground-fault test can also be done using the UTS-3 secondary injection test kit. These secondary injection test sets do not test the current transformers and connections.

**Tests for Ground-Fault Alarm Only: LE, ME, NE, PE and SE Circuit Breakers**

All LE, ME, NE, PE, and SE circuit breakers with the ground-fault alarm feature are supplied with an integral ground-fault test feature. A 120 V power source is required to operate the integral test feature. The test circuitry simulates a ground-fault when the test button on the front of the circuit breaker is depressed. The ammeter in the circuit breaker will indicate a current value while the push-to-test button is engaged.

**NOTE:** The ground-fault alarm only circuit breaker will not trip or indicate a trip when the push-to-test button on the front of the circuit breaker is pressed.

When connected to a Powerlogic system via a communications adapter (Square D catalog number CIM3F), the Powerlogic system will indicate a ground-fault current value while the push-to-test button is engaged. The Powerlogic system indicates an alarm condition if the push-to-test button is pressed for two seconds. The circuit breaker takes a maximum of one second to communicate an alarm condition. The Powerlogic system updates the condition only as frequently as the scan time is set on the Powerlogic system.

Instructions for the ground-fault trip test, page 31, can be applied to ground-fault alarm only circuit breakers with the following exceptions:

- A. Ground-fault alarm only circuit breakers have no trip or delay features. Therefore the Universal Test Set (catalog number UTS3) will display no time values.
- B. Ground-fault zone-selective interlocking is not available on ground-fault alarm only circuit breakers.
- C. If the pulse test method is used, the pulse signal must be long enough for the Powerlogic system to recognize the alarm condition.

When secondary injection testing using the UTS3 test set, the circuit breaker must be disconnected from the Powerlogic system. To disconnect the circuit breaker from the Powerlogic system, detach the 4-pin plug connection on the adapter. The test set will indicate the circuit breaker failed if the Powerlogic system remains connected when testing. After testing, reconnect the four-pin plug to the adapter. Follow the instructions for the version of Powerlogic software that is installed on the system to verify that the communication has been re-established with the circuit breaker.

**NOTE:** Testing a circuit breaker connected to a Powerlogic system causes the Powerlogic system to react as if the circuit breaker were experiencing the actual faults.

**Contact Resistance Test**

Circuit breaker pole resistance tests are not reliable indicators of circuit breaker performance because the resistance values are influenced by a number of transient factors including contact surface oxidation, foreign material between the contacts, and testing methods. NEMA AB 4 paragraph 6.4.1 states: “The millivolt drop of a circuit breaker pole can vary significantly due to inherent variability in the extreme low resistance of the electrical contacts and connectors. Such variations do not necessarily predict unacceptable performance and shall not be used as the sole criteria for determination of acceptability.”

High pole resistance may also be caused by eroded contacts, low contact force, and loose termination. The only one of these factors likely to be present on a new circuit breaker is a loose termination, since the contacts are new and there has been no opportunity for contact pressure to have drifted from the factory setting. A loose termination can be corrected in the field.

If a contact resistance test is done, it is important to do it after the contacts have been conditioned by instantaneous primary injection testing to ensure the contacts are clear of resistive films, oxidation and foreign material. If the circuit breaker has been in service with no performance issues, (overheating or nuisance tripping), contact resistance measurements are redundant and of little value.

Square D recommends that a DLRO (Digital Low Resistance Ohmmeter) be used, using a 10 A dc test current for circuit breaker ratings below 100 A, and using 100 A dc for circuit breakers rated 100 A and above. the median (middle) value of three readings (toggling the circuit breaker between each reading) should be recorded for each pole tested. If this value is equal to or less than the value listed in Table 6, the pole is acceptable. If the reading is higher, the cause should be investigated and corrected if possible. Contact your local field office for more information.

**Table 6: Maximum Micro-Ohms Per Pole**

Circuit Breaker		Micro-Ohms (u ohm)	Circuit Breaker		Micro-Ohms (u ohm)
Type	Rating		Type	Rating	
LE, LX	300	477	NE, NX	600	112
	350	416		700	106
	400	250		800	85
	450	310		900	81
	500	286		1000	66
	600	169		1200	56
ME, MX	125	1,600	PE, PX	600	106
	150	1,500		700	100
	175	914		800	81
	200	725		1000	63
	225	593		1200	53
	250	488		1400	49
	300	344		1600	41
	350	261		1800	35
	400	200		2000	31
	450	146		2500	33
	500	114		600	106
	600	94		700	100
	700	78		800	81
	800	68		1000	63
		1200	53		

**Remove Test Connections**

Upon completing testing:

- Remove test connections from circuit breaker.
- Inspect connections for damage caused by testing.
- Reset the long-time pickup switch to original settings, as recorded in above.
- If an auxiliary power supply is being used for the Micrologic trip unit, reconnect the auxiliary power supply.

**Additional Information**

For more information concerning Square D circuit breakers, refer to the appropriate instruction manual. These manuals contain installation instructions, mounting information, safety features, wiring diagrams, and troubleshooting charts for specific circuit breakers.

## Section 6—Available Test Equipment

### Test Equipment for L-, M-, N-, P- and S-Frame Circuit Breakers with Micrologic™ Trip Units

#### Local Current Meter Kit

Local current meters (catalog numbers ALAM and ALAMP) offer real-time current metering capabilities and, if the circuit breaker trips, the meters indicate the type of trip:

- Overload
- Short circuit
- Ground fault

The current meter provides a simple means of troubleshooting the cause of a trip, and comes installed in all full-function (LE, ME, NE, PE and SE) circuit breakers. The current meter provides on-line assistance with:

- Identifying overloaded or unbalanced phases
- Defining the level of ground-fault current flowing on the circuit

The ALAM kit is for use with all series of L-, M-, N- and S-frame Micrologic™ electronic-trip circuit breakers. The ALAMP kit is for use on all series of P-frame Micrologic Electronic-trip circuit breakers, and is different only because of the orientation of the trip unit cavity.

#### Memory-Reset Module

Memory reset modules (catalog numbers MTMB, MTM2 and MTM3) are used to reset the long-time memory on Micrologic electronic-trip circuit breakers. This allows faster primary injection testing of the circuit breaker.

- The MTMB module is for use with Micrologic Series B electronic-trip systems.
- The MTM3 module is for use with Micrologic Series 3 trip systems
- The MTM2 module is for use with Series 2 SE electronic-trip circuit breakers.

#### Primary Injection Test Kit

Adapter plug kits (catalog numbers SEPITK1 and SEPITK2) use jumpers in certain terminals to properly connect the secondary sensing wiring in SE drawout construction circuit breakers. The SEPITK1 test kit is for use with Series 1 SED circuit breakers; the SEPITK2 test kit is for use with Series 2 and above SED circuit breakers.

#### Universal Test Set

The optional Universal Test Set (catalog number UST3) is a microprocessor-based system used to test all LE, LX, LXI, ME, MX, NE, NX, PE, PX and SE Micrologic circuit breakers. This test set will thoroughly test each function of the trip unit. The Universal Test Set is a secondary injection tester and does not take current transformer tolerances into consideration.

The UTS3 test set includes:

- The test module for standard and full-function Micrologic Series B trip systems
- A self-test module
- A power cord
- A ribbon cable
- An instruction manual

## Test Equipment for PowerPact™ P/R Circuit Breakers with Micrologic Electronic Trip Units

### Full-Function Test Kit

The Full-Function Test Kit is a microprocessor-based system used to test Compact™ NSJ, and PowerPact™ circuit breakers with Micrologic electronic-trip units. The Full-Function Test Kit is a secondary injection tester and does not test the current transformers and connections.

The Full-Function Test Kit is designed to be used as a stand-alone test unit or in conjunction with a personal computer. The Full-Function Test Kit alone performs the following tests:

- Protection function verification (LSIG)
- Compliance with trip curve
- Electrical and mechanical tests of trip system
- Zone-selective interlocking tests
- Inhibition of ground-fault protection for use during primary injection testing
- Inhibition of thermal imaging for use during primary injection testing
- Supply control power to the trip unit to energize displays

### Hand-Held Test Kit

The Hand-Held Test Kit is a small battery-powered unit. It is designed to provide convenient secondary injection tests on Compact NSJ and PowerPact circuit breakers with Micrologic electronic-trip units. The Hand-Held Test Kit is powered by five 9 V batteries and can be used to do the following:

- Verify trip unit operation by tripping the circuit breaker with a secondary injection signal
- Supply control power to the trip unit to energize displays
- Inhibit thermal imaging for primary injection testing
- Inhibit ground-fault for primary injection testing
- Zone-selective interlocking tests<sup>1</sup>

## Available Test Equipment for PowerPact H/J/L Circuit Breakers with Micrologic Electronic-Trip Units

### Pocket Tester



Pocket Tester

The pocket tester connects to the Micrologic trip unit test connector. It powers up the Micrologic trip unit and the Ready LED. It supplies the screen, allows settings to be made using the keypad, and provides thermal memory inhibit functions.

The pocket tester runs off of two Alkaline AA batteries.

<sup>1</sup> Only provides power to trip unit to indicate a ZSI signal was received. Will not initiate the command to send a ZSI restraint signal.

## UTA Tester for Test and Maintenance

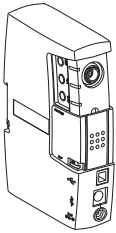

UTA Tester Module

The UTA Tester includes:

- configuration and maintenance module
- power supply (110–220 Vac / 50-60 Hz 24 Vdc - 1 A)
- special Micrologic cable for connection to the trip-unit test connector
- standard USB cable
- standard RJ45 cable
- user manual

Included in the UTA Tester, the UTA Tester module tests Micrologic trip unit operation and provides access to all parameters and settings. It connects to the Micrologic trip unit test connector and can operate in two modes.

Stand-alone mode to:

- supply the Micrologic trip unit with power and check operation using the Ready LED

- Provides ground-fault inhibit and thermal memory inhibit

PC mode, connected to a PC with a USB or Bluetooth link. This mode provides access to protection settings, alarm settings and readings of all indicators. Using the associated RSU software utility, it is possible to store, in a dedicated file for each device, all the data that can transferred to another device.

This mode also offers operating-test functions:

- check on trip time delay (trip curve)
- check on non-tripping time (coordination)
- check on ZSI function
- alarm simulation
- display of setting curves
- display of currents
- printing of test reports
- optional Bluetooth link (to PC).

