

What is the use of direction setting as Line and Busbar in directional protection?

First of all this setting is available through both directional overcurrent/ earth fault in advance parameters. Please see following figures in below.

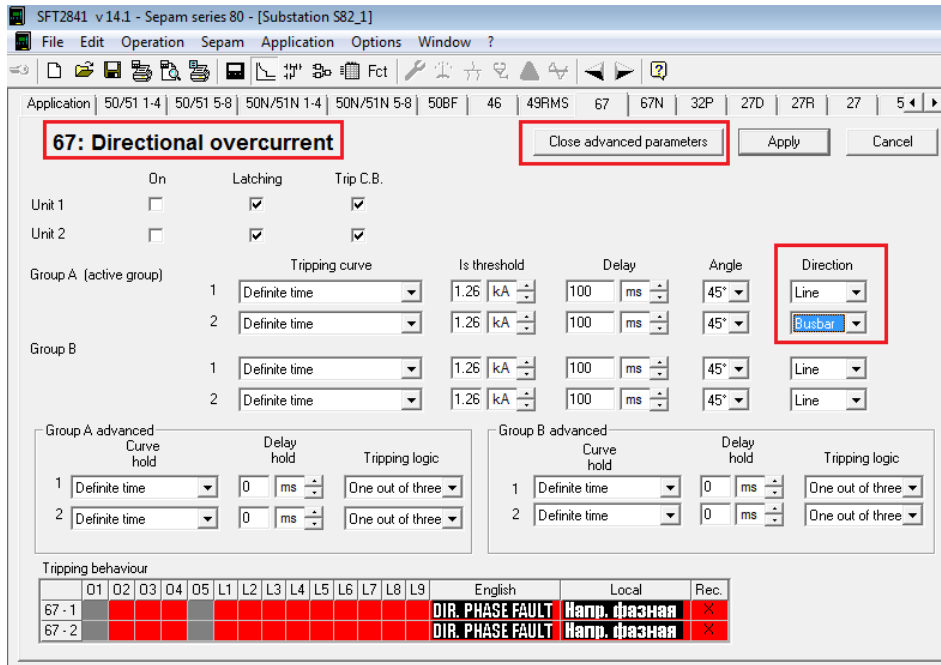

Figure 1: direction setting in 67

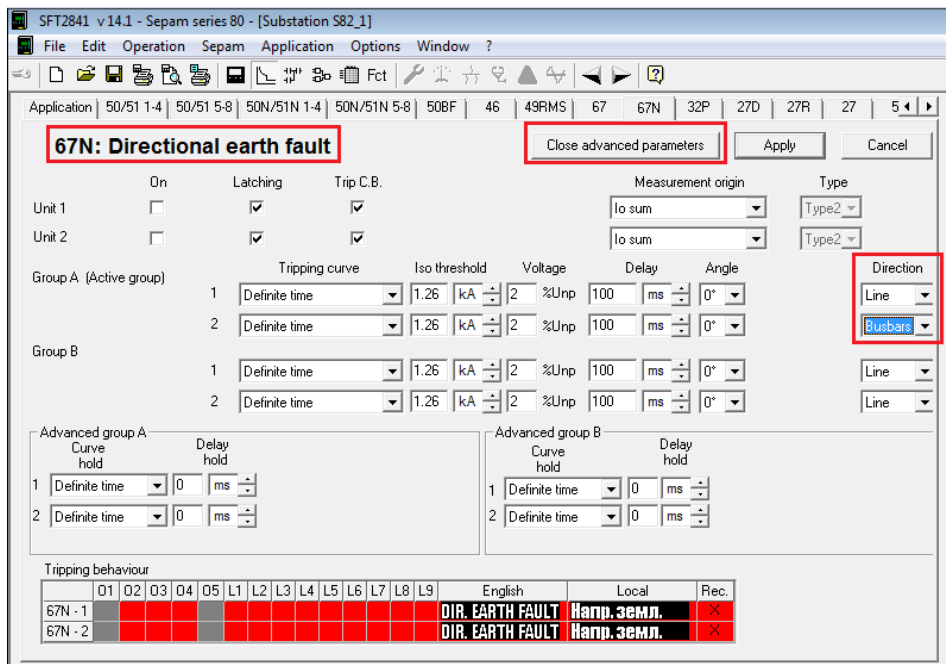

Figure 2: direction setting in 67N

This setting is enormously important as will affect the tripping behavior of directional protection.

As an illustration (using the figures printed in 67 directional protection in Sepam user manuals), you can see here in figure 3 that relay operating zone could either start to trip in line or in busbar direction. The operation zone of relay should be decided and set by this setting option.

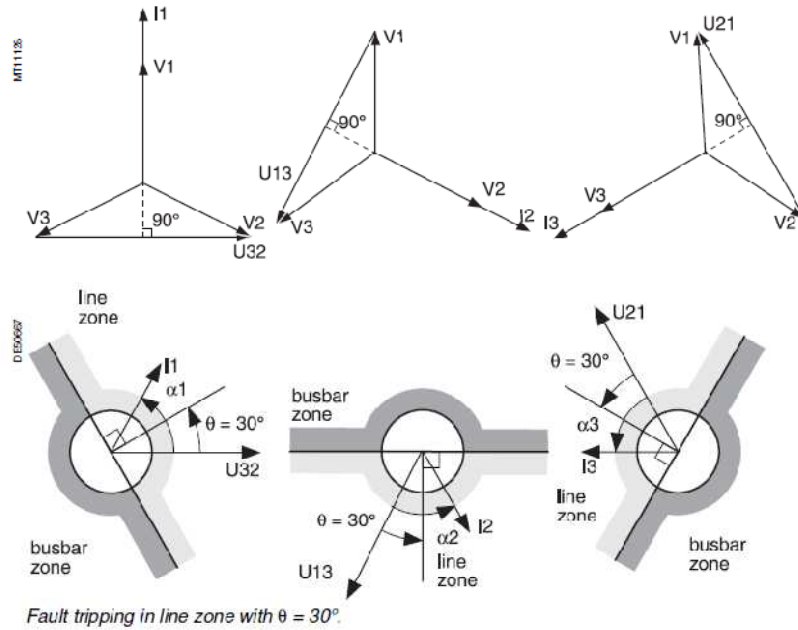

Figure 3- different operating zones according to line or bus-bar direction setting

We grab your attention into the fact that, in order to make it easier to be understood, the voltage and the current vectors in above figures are in line, actually it is because of assuming the load as a resistance load. With this assumption and also considering below connection diagram between CTs installed on power lines and the relay and also power flowing from A point to B, then you would have the same line direction and bus direction as printed in Figure3. Actually as line voltage (U32, U13, U21) are used as a reference to distinguish polarization of voltage so in following diagram voltage transformer also is shown.

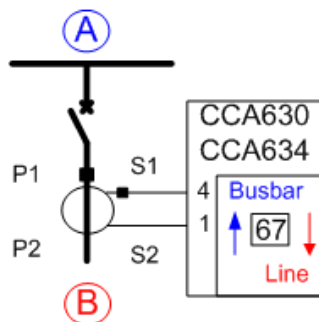

Figure 4

Just to give some examples to make it clearer, following schemes are identical. Assume that power is flowing from point A to point B. It means that current is entering terminal 4 in both cases. Moreover we have got voltage reference (an important index for directional calculation) on the bus-bar side (where voltage source is connected).

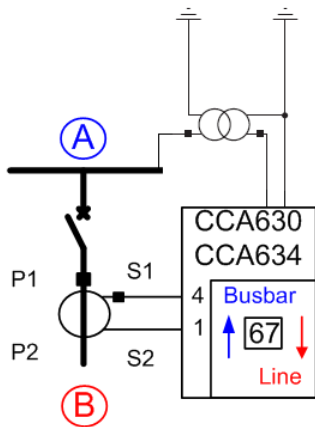

Figure 5

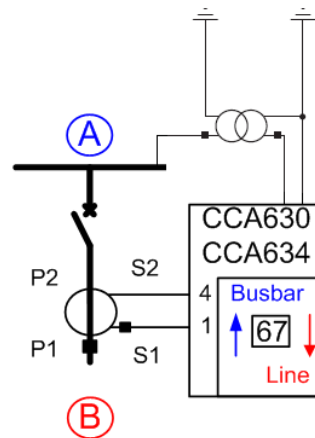

Figure 6

In Figure 5 and 6, while the direction is set to bus-bar all faults in position A will be detected. Also while direction is set to Line then all faults in position B will be detected.

These following schemes also are identical. Assume that power is flowing from point A to point B. It means that current is entering terminal 1 in both cases. Moreover we have got voltage reference (an important index for directional calculation) on the bus-bar side (where voltage source is connected).

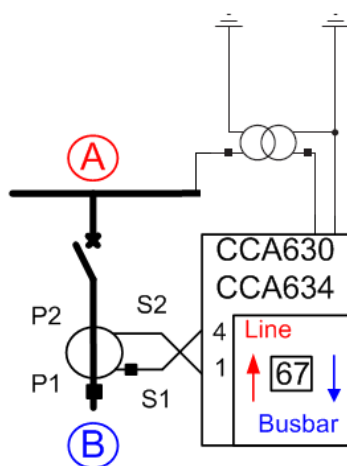

Figure 7

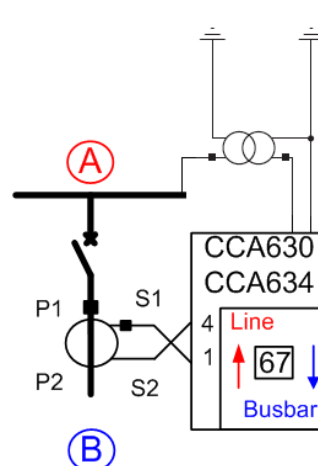

Figure 8

In Figure 7 and 8, while the direction is set to bus-bar all faults in position B will be detected. Also while direction is set to Line then all faults in position A will be detected. AEDL3