

# Programming

## Description of the HMI

### Functions of the display and the keys

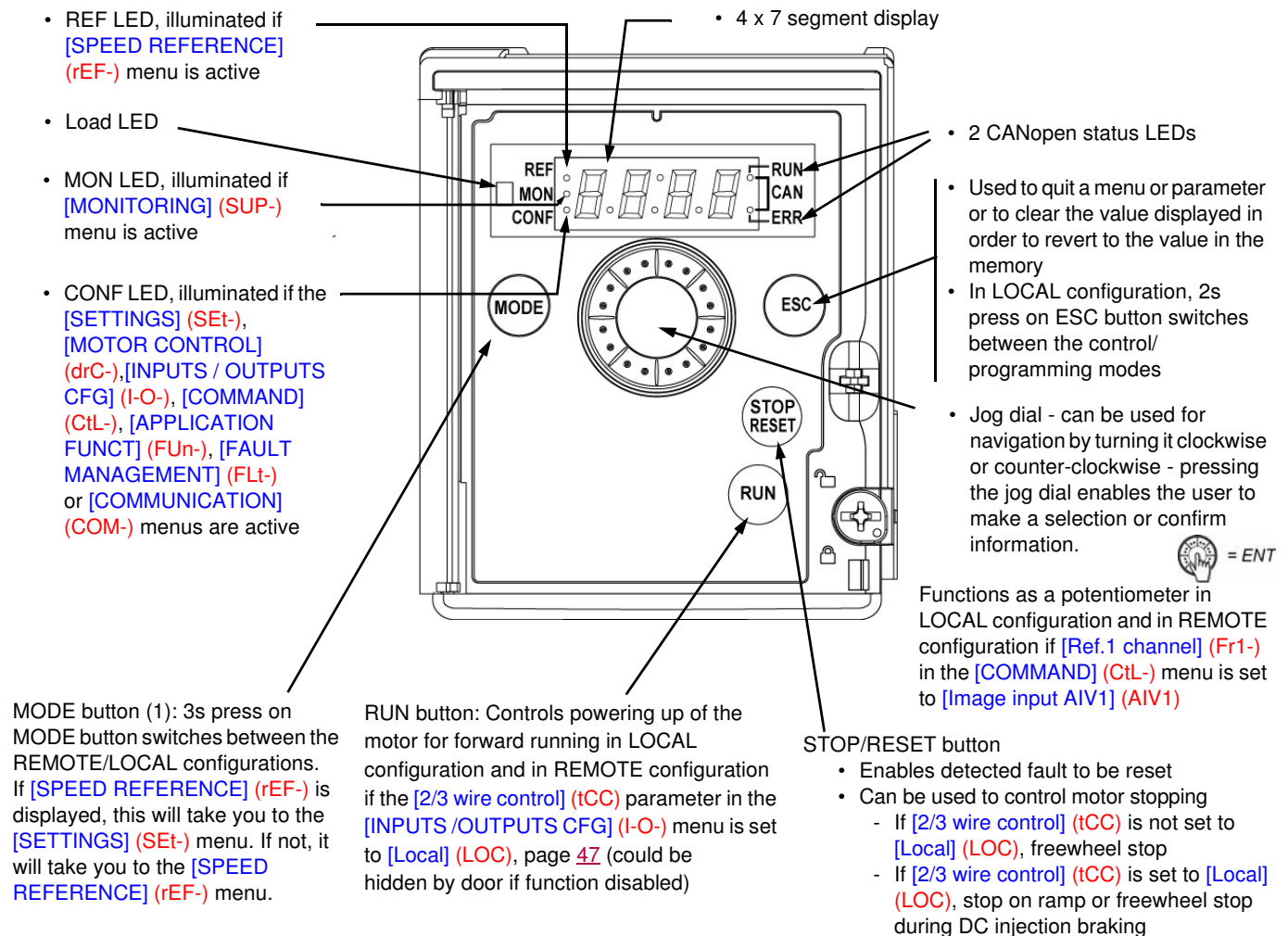

**Note1:** In LOCAL configuration, the three Leds REF, MON, and CONF are blinking simultaneously in programming mode and are working as a Led chaser in control mode.

#### Normal display, with no fault code displayed and no startup:

- **43.0**: Displays the parameter selected in the **[MONITORING] (SUP-)** menu (default: motor frequency). If the current is limited, the display flashes. In such cases, CLI will appear at the top left if an ATV61/ATV71 graphic display terminal is connected to the drive.
- **InIt**: Initialization sequence
- **r d y**: Drive ready
- **d C b**: DC injection braking in progress
- **n S t**: Freewheel stop
- **F S t**: Fast stop
- **t U n**: Auto-tuning in progress

In the event of a detected fault, the display will flash to notify the user accordingly. If an ATV61/ATV71 graphic display terminal is connected, the name of the detected fault will be displayed.

- (1) If the drive is locked by a code (**[PIN code 1] (COd)**, page 103), pressing the Mode key enables you to switch from the **[MONITORING] (SUP-)** menu to the **[SPEED REFERENCE] (rEF-)** menu and vice versa. It is no longer possible to switch between LOCAL and REMOTE configurations.

# Programming

## REMOTE and LOCAL configuration

The LOCAL configuration allows to activate automatically the embedded RUN button and the jog dial as a potentiometer. In that configuration, the speed adjustment will also be effective on remote keypads. MODE button on ATV12 remote display terminal and on ATV61/71 graphic display terminal (function key F4) is also active to switch from one configuration to another.

[Ref.1 channel] (Fr1) is set to [AI Virtual 1] (AIV1) and [2/3 wire control] (tCC) are set to [2 wire] (2C) when switching to LOCAL configuration.

For parameters interdependencies reasons, switching from one configuration to another will change other parameters (for example : Input/Output assignment will return to their factory value). **Choose the configuration (REMOTE or LOCAL) before starting the parameters adjustment of the drive.**

## Structure of the menus

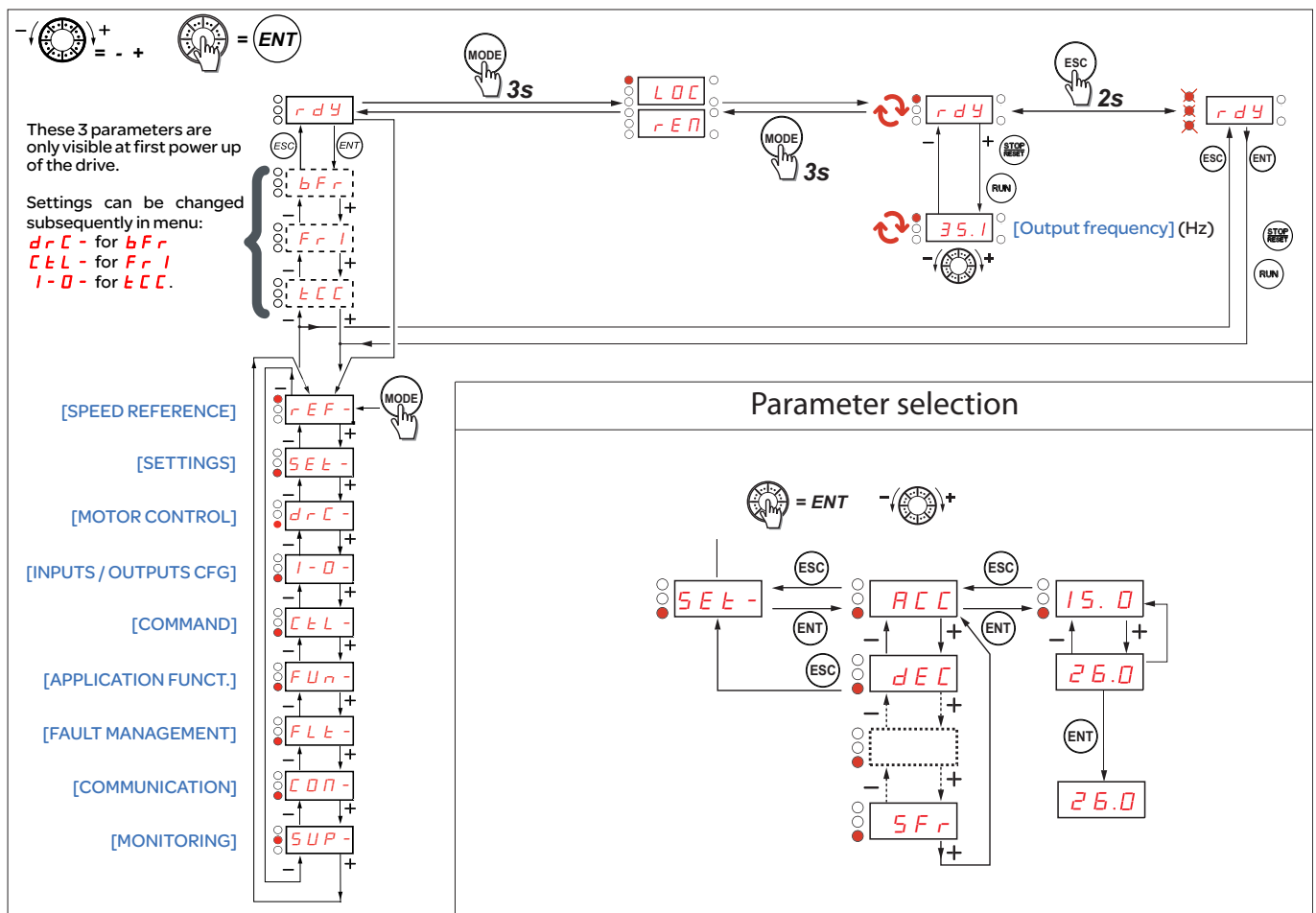

On the 7-segment display, a dash after menu and submenu codes is used to differentiate them from parameter codes.

Examples: [APPLICATION FUNCT.] (FU n-) menu, [Acceleration] (ACC) parameter

# [MOTOR CONTROL] (drC-) menu

rEF -  
SEt -  
**drC -**  
I-D -  
CLt -  
FU -  
FLt -  
COn -  
SUP -

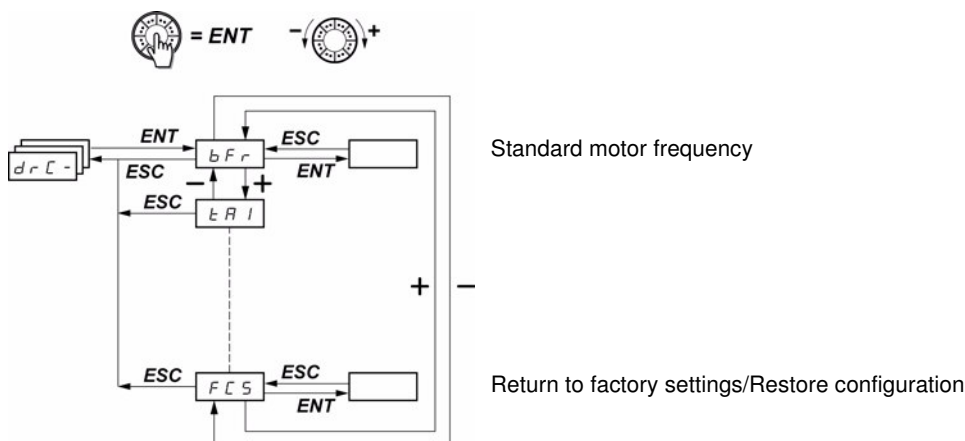

With the exception of [Auto tuning] (tUn), which can power up the motor, parameters can only be changed in stop mode, with no run command present.

On the optional ATV31 remote display terminal, this menu can be accessed with the switch in the position.

Drive performance can be optimized by:

- Entering the values given on the motor rating plate in the Drive menu
- Performing an auto-tune operation (on a standard asynchronous motor)

Code	Description	Adjustment range	Factory setting
<b>bFr</b> SD 60	<input type="checkbox"/> <b>[Standard mot. freq]</b> [50Hz IEC] (50): 50 Hz: IEC [60Hz NEMA] (60): 60 Hz: NEMA This parameter modifies the presets of the following parameters: [High speed] (HSP), page 33, [Freq. threshold] (Ftd), page 39, [Rated motor freq.] (FrS), page 41, and [Max frequency] (tFr), page 44.		[50Hz IEC] (50)
<b>UnS</b>	<input type="checkbox"/> <b>[Rated motor volt.]</b> Nominal motor voltage given on the rating plate. When the line voltage is lower than the nominal motor voltage, set [Rated motor volt.] (UnS) to the same value as the line voltage for the drive terminals. ATV312●●●M2: 100 to 240 V ATV312●●●M3: 100 to 240 V ATV312●●●N4: 100 to 500 V ATV312●●●S6: 100 to 600 V	In accordance with the drive rating	In accordance with the drive rating
<b>FrS</b>	<input type="checkbox"/> <b>[Rated motor freq.]</b> Nominal motor frequency marked on the rating plate. The factory setting is 50 Hz, or 60 Hz if [Standard mot. freq] (bFr) is set to 60 Hz. <b>Note:</b> The ratio $\frac{[\text{Rated motor volt.}] (UnS) \text{ (in volts)}}{[\text{Rated motor freq.}] (FrS) \text{ (in Hz)}}$ must not exceed the following values: ATV312●●●M2: 7 max. ATV312●●●M3: 7 max. ATV312●●●N4: 14 max. ATV312●●●S6: 17 max. The factory setting is 50 Hz, or preset to 60 Hz if [Standard mot. freq] (bFr) is set to 60 Hz.	10 to 500 Hz	50 Hz
<b>nCr</b>	<input type="checkbox"/> <b>[Rated mot. current]</b> Nominal motor current given on the rating plate.	0.25 to 1.5 In (1)	In accordance with the drive rating

(1) In corresponds to the nominal drive current indicated in the Installation Manual and on the drive nameplate.

# [MOTOR CONTROL] (drC-) menu

rEF -  
SEt -  
drC -  
I-D -  
CLL -  
FUN -  
FLt -  
CON -  
SUP -

Code	Description	Adjustment range	Factory setting
nSP	<input type="checkbox"/> <b>[Rated motor speed]</b>  0 to 9,999 rpm then 10.00 to 32.76 krpm If, rather than the nominal speed, the nameplate indicates the synchronous speed and the slip in Hz or as a %, calculate the nominal speed as follows: <ul style="list-style-type: none"> <li>• Nominal speed = synchronous speed x <math>\frac{100 - \text{slip as a \%}}{100}</math> or</li> <li>• Nominal speed = synchronous speed x <math>\frac{50 - \text{slip in Hz}}{50}</math> (50 Hz motors) or</li> <li>• Nominal speed = synchronous speed x <math>\frac{60 - \text{slip in Hz}}{60}</math> (60 Hz motors)</li> </ul>	0 to 32,760 rpm	In accordance with the drive rating
COS	<input type="checkbox"/> <b>[Motor 1 Cosinus Phi]</b>  Motor Cos Phi given on the motor rating plate	0.5 to 1	In accordance with the drive rating
rSC nD InIt BBBB	<input type="checkbox"/> <b>[Cold stator resist.]</b>  <input type="checkbox"/> [No] (nO): function inactive. For applications which do not require high performance or do not tolerate automatic auto-tuning (passing a current through the motor) each time the drive is powered up. <input type="checkbox"/> [Init] (InIt): activates the function. To improve low-speed performance whatever the thermal state of the motor. <input type="checkbox"/> Value of cold state stator resistance used, in mΩ. <b>Note:</b> <ul style="list-style-type: none"> <li>• It is strongly recommended that this function is activated for mechanical handling applications.</li> <li>• The function should only be activated [Init] (InIt) when the motor is cold.</li> <li>• When [Cold stator resist.] (rSC) = [Init] (InIt), the [Auto-tuning] (tUn) parameter is forced to [Power on] (POn). At the next run command the stator resistance is measured with an auto-tune. The [Cold stator resist.] (rSC) then changes to a value of (BBBB) and maintains it, [Auto-tuning] (tUn) is still forced to [Power on] (POn). The [Cold stator resist.] (rSC) parameter remains at [Init] (InIt) as long as the measurement has not been performed.</li> <li>• Value BBBB can be forced or changed using the jog dial (1).</li> </ul>		[No] (nO)

(1) Procedure:

- Check that the motor is cold.
- Disconnect the cables from the motor terminals.
- Measure the resistance between 2 of the motor terminals (U. V. W.) without modifying its connection.
- Use the jog dial to enter half the measured value.
- Increase the factory setting of [IR compensation] (UFR), page 33, to 100% rather than 20%.

**Note:** Do not use [Cold stator resist.] (rSC) if it is not set to [No] (nO) or = [Power on] (POn) with catch on the fly ([CATCH ON THE FLY] (FLr-), page 93).

# [MOTOR CONTROL] (drC-) menu

rEF -  
SEt -  
drC -  
I - D -  
CLL -  
FUN -  
FLt -  
CON -  
SUP -

Code	Description	Adjustment range	Factory setting
tUn	<p><input type="checkbox"/> [Auto tuning]</p> <p style="text-align: center;"><b>⚡ ⚠ DANGER</b></p> <p><b>HAZARD OF ELECTRIC SHOCK, EXPLOSION, OR ARC FLASH</b></p> <ul style="list-style-type: none"> <li>During auto-tuning the motor operates at nominal current.</li> <li>Do not work on the motor during auto-tuning.</li> </ul> <p><b>Failure to follow these instructions will result in death or serious injury.</b></p> <p style="text-align: center;"><b>⚠ WARNING</b></p> <p><b>LOSS OF CONTROL</b></p> <ul style="list-style-type: none"> <li>It is essential that the [Rated motor volt.] (UnS), [Rated motor freq.] (FrS), [Rated motor freq.] (nCr), [Rated motor speed] (nSP), [Motor 1 Cosinus Phi.] (COS) parameters are configured correctly before starting auto-tuning.</li> <li>When one or more parameters have been changed after auto-tuning has been performed, [Auto-tuning] (tUn) will return [No] (nO) and the procedure will have to be repeated.</li> </ul> <p><b>Failure to follow these instructions will result in death, serious injury, or equipment damage.</b></p> <ul style="list-style-type: none"> <li><input type="checkbox"/> [No] (nO): Auto-tuning not performed</li> <li><input type="checkbox"/> [Yes] (YES): Auto-tuning is performed as soon as possible, then the parameter automatically changes to [Done] (dOnE) or [No] (nO) in the event that Auto-tuning is not successful [AUTO TUNING FAULT] (tnF) is displayed if [Autotune fault mgt] (tnL) = [Yes] (YES), page 95).</li> <li><input type="checkbox"/> [Done] (dOnE): Use of the values given the last time auto-tuning was performed</li> <li><input type="checkbox"/> [Drv running] (rUn): Auto-tuning is performed every time a run command is sent.</li> <li><input type="checkbox"/> [Power on] (POn): Auto-tuning is performed on every power-up.</li> <li><input type="checkbox"/> [LI1] to [LI16] (LI1) to (LI6): Auto-tuning is performed on the transition from 0 → 1 of a logic input assigned to this function.</li> </ul> <p style="text-align: center;"><b>⚡ ⚠ DANGER</b></p> <p><b>HAZARD OF ELECTRIC SHOCK OR ARC FLASH</b></p> <p>When [Auto tuning] (tUn) is set [Power on] (POn), Auto tune will be performed every time the power will be switched on.</p> <ul style="list-style-type: none"> <li>Check this action will not endanger personnel or equipment in any way.</li> </ul> <p><b>Failure to follow these instructions will result in death or serious injury.</b></p> <p><b>Note:</b> [Auto-tuning] (tUn) is forced to [Power on] (POn) if [Cold stator resist.] (rSC) = [Init] (InIt). Auto-tuning is only performed if no command has been activated. If a "freewheel stop" or "fast stop" function is assigned to a logic input, this input must be set to 1 (active at 0). Auto-tuning may take 1 to 2 seconds. Do not interrupt the process. Wait for the display to change to [Done] (dOnE) or [No] (nO).</p>		[No] (nO)
tUS	<p><input type="checkbox"/> [Auto tuning state]</p> <p>(For information only, cannot be modified)</p> <ul style="list-style-type: none"> <li><input type="checkbox"/> [Not done] (tAb): The default stator resistance value is used to control the motor.</li> <li><input type="checkbox"/> [Pending] (PEnd): Auto-tuning has been requested but not yet performed.</li> <li><input type="checkbox"/> [In Progress] (PrOG): Auto-tuning in progress.</li> <li><input type="checkbox"/> [Failed] (FAIL): Auto-tuning was unsuccessful.</li> <li><input type="checkbox"/> [Done] (dOnE): The stator resistance measured by the auto-tuning function is used to control the motor.</li> <li><input type="checkbox"/> [Entered R1] (Strd): The cold state stator resistance ([Cold stator resist.] (rSC) which is not set to [No] (nO)) is used to control the motor.</li> </ul>		[Not done] (tAb)

nO  
YES  
  
dOnE  
rUn  
POn  
LI1  
to  
LI6

tAb  
PEnd  
PrOG  
FAIL  
dOnE  
Strd

# [FAULT MANAGEMENT] (FLt-) menu

rEF -  
SEt -  
drC -  
I-D -  
CLL -  
FUN -  
FLt -  
COP -  
SUP -

Code	Description	Adjustment range	Factory setting
<b>OPL</b>  nO YES OAC	<input type="checkbox"/> <b>[Output Phase Loss]</b>  <div style="background-color: black; color: white; text-align: center; padding: 5px;"> <b>⚠ ⚠ DANGER</b> </div> <div style="background-color: yellow; padding: 5px;"> <b>HAZARD OF ELECTRIC SHOCK, EXPLOSION, OR ARC FLASH</b>            If <b>[Output Phase Loss] (OPL)</b> is set to <b>nO</b> loss of cable is not detected            • Check this action will not endanger personnel or equipment in any way   <b>Failure to follow these instructions will result in death or serious injury.</b> </div> <input type="checkbox"/> <b>[No] (nO)</b> : Function inactive <input type="checkbox"/> <b>[Yes] (YES)</b> : Tripping on the <b>[MOTOR PHASE LOSS] (OPF)</b> <input type="checkbox"/> <b>[Output cut] (OAC)</b> : No tripping on a <b>[MOTOR PHASE LOSS] (OPF)</b> , but management of the output voltage in order to avoid an overcurrent when the link with the motor is re-established and catch on the fly performed even if <b>[Catch on the fly] (FLr) = [No] (nO)</b> . To be used with output contactor. <b>[Output Phase Loss] (OPL)</b> is forced to <b>[Yes] (YES)</b> if <b>[Brake assignment] (bLC)</b> is not set to <b>[No] (nO)</b> , page <b>85</b> .		<b>[Yes] (YES)</b>
<b>IPL</b>  nO YES	<input type="checkbox"/> <b>[Input phase loss]</b>  This parameter is only accessible on 3-phase drives. <input type="checkbox"/> <b>[No] (nO)</b> : Ignore <input type="checkbox"/> <b>[Yes] (YES)</b> : Detected fault management with fast stop		<b>[Yes] (YES)</b>
<b>OHL</b>  nO YES rPP FSt	<input type="checkbox"/> <b>[Overtemp fault mgt]</b>  <div style="text-align: center; background-color: yellow; padding: 5px;"> <b>CAUTION</b> </div> <div style="background-color: yellow; padding: 5px;"> <b>RISK OF DAMAGE TO THE MOTOR</b>            Inhibiting drive overheating fault detection results in the drive not being protected. This invalidates the warranty.            • Check that the possible consequences do not present any risk.   <b>Failure to follow these instructions can result in equipment damage.</b> </div> <input type="checkbox"/> <b>[Ignore] (nO)</b> : Ignore <input type="checkbox"/> <b>[Freewheel] (YES)</b> : Detected fault management with freewheel stop <input type="checkbox"/> <b>[Ramp stop] (rMP)</b> : Detected fault management with stop on ramp <input type="checkbox"/> <b>[Fast stop] (FSt)</b> : Detected fault management with fast stop		<b>[Freewheel] (YES)</b>
<b>OLL</b>  nO YES rPP FSt	<input type="checkbox"/> <b>[Overload fault mgt]</b>  <div style="text-align: center; background-color: yellow; padding: 5px;"> <b>CAUTION</b> </div> <div style="background-color: yellow; padding: 5px;"> <b>RISK OF DAMAGE TO THE MOTOR</b>            If <b>[Overload fault mgt]</b> is set to <b>nO</b>, motor thermal protection is no longer provided by the drive. Provide an alternative means of thermal protection.   <b>Failure to follow these instructions can result in equipment damage.</b> </div> <input type="checkbox"/> <b>[Ignore] (nO)</b> : Ignore <input type="checkbox"/> <b>[Freewheel] (YES)</b> : Detected fault management with freewheel stop <input type="checkbox"/> <b>[Ramp stop] (rMP)</b> : Detected fault management with stop on ramp <input type="checkbox"/> <b>[Fast stop] (FSt)</b> : Detected fault management with fast stop		<b>[Freewheel] (YES)</b>

## Diagnostics and troubleshooting (continued)

### Fault detection codes that can be reset with the automatic restart function after the cause has disappeared (continued)

Code	Name	Probable cause	Remedy
<b>O L F</b>	<b>[MOTOR OVERLOAD]</b>	<ul style="list-style-type: none"> <li>Triggered by excessive motor current</li> <li><b>[Cold stator resist.] (rSC)</b> parameter value incorrect</li> </ul>	<ul style="list-style-type: none"> <li>Check the <b>[Mot. therm. current] (ItH)</b> setting, page 33, of the motor thermal protection, check the motor load. Wait for the drive to cool before restarting.</li> <li>Remeasure <b>[Cold stator resist.] (rSC)</b>, page 42.</li> </ul>
<b>O P F</b>	<b>[MOTOR PHASE LOSS]</b>	<ul style="list-style-type: none"> <li>Loss of one phase at drive output</li> <li>Output contactor open</li> <li>Motor not connected or motor power too low</li> <li>Instantaneous instability in the motor current</li> </ul>	<ul style="list-style-type: none"> <li>Check the connections from the drive to the motor.</li> <li>If an output contactor is being used, set <b>[Output Phase Loss] (OPL)</b> to <b>[Output cut] (OAC)</b> (<b>[FAULT MANAGEMENT] (FLt-)</b> menu, page 94).</li> <li>Test on a low-power motor or without a motor: In factory settings mode, motor output phase loss detection is active (<b>[Output Phase Loss] (OPL) = [Yes] (YES)</b>). To check the drive in a test or maintenance environment without having to switch to a motor with the same rating as the drive (particularly useful in the case of high-power drives), deactivate motor phase loss detection (<b>[Output Phase Loss] (OPL) = [No] (nO)</b>).</li> <li>Check and optimize the <b>[IR compensation] (UFr)</b>, <b>[Rated motor volt.] (UnS)</b>, and <b>[Rated mot. current] (nCr)</b> parameters, and perform an <b>[Auto tuning] (tUn)</b> operation, page 43.</li> </ul>
<b>O S F</b>	<b>[MAINS OVERVOLTAGE]</b>	<ul style="list-style-type: none"> <li>Line voltage is too high.</li> <li>Disturbed line supply</li> </ul>	<ul style="list-style-type: none"> <li>Check the line voltage.</li> </ul>
<b>P H F</b>	<b>[INPUT PHASE LOSS]</b>	<ul style="list-style-type: none"> <li>Drive incorrectly supplied or a fuse blown</li> <li>Failure of one phase</li> <li>Three-phase ATV312 used on a single-phase line supply</li> <li>Unbalanced load</li> </ul> <p>This protection only operates with the drive on load</p>	<ul style="list-style-type: none"> <li>Check the power connection and the fuses.</li> <li>Reset</li> <li>Use a three-phase line supply.</li> <li>Disable the detection by setting <b>[Input phase loss] (IPL) = [No] (nO)</b> (<b>[FAULT MANAGEMENT] (FLt-)</b> menu, page 94).</li> </ul>
<b>S L F</b>	<b>[MODBUS FAULT]</b>	<ul style="list-style-type: none"> <li>Interruption in communication on the Modbus bus</li> <li>Remote display terminal enabled (<b>[HMI command] (LCC) = [Yes] (YES)</b>, page 61) and terminal disconnected.</li> </ul>	<ul style="list-style-type: none"> <li>Check the communication bus</li> <li>Refer to the relevant product documentation.</li> <li>Check the link with the remote display terminal.</li> </ul>