

Earth-leakage protection

Connection of the rectangular-sensor secondary circuit:

Compact NS equipped with a Micrologic 7 A/P:
use the cable shipped with the rectangular sensor.

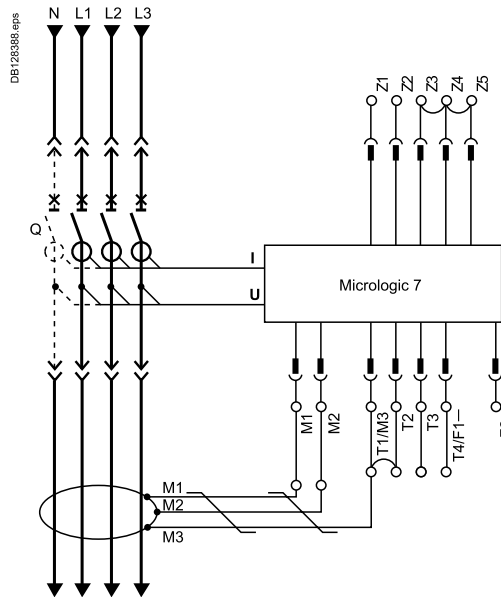

Neutral protection

- Three pole circuit breaker:
 - neutral protection is impossible with Micrologic A/E
 - with Micrologic P, an external neutral transformer is necessary; the connection diagram is the same as for residual earth-fault protection.
- Four pole circuit breaker:
 - Compact NS equipped with Micrologic A/E/P
 - the current transformer for external neutral is not necessary.

Zone selective interlocking

Zone-selective interlocking is used to reduce the electrodynamic forces exerted on the installation by shortening the time required to clear faults, while maintaining time discrimination between the various devices.

A pilot wire interconnects a number of circuit breakers equipped with Micrologic A/E/P control units, as illustrated in the diagram above.

The control unit detecting a fault sends a signal upstream and checks for a signal arriving from downstream. If there is a signal from downstream, the circuit breaker remains closed for the full duration of its tripping delay. If there is no signal from downstream, the circuit breaker opens immediately, regardless of the tripping-delay setting.

Fault 1.

Only circuit breaker A detects the fault. Because it receives no signal from downstream, it immediately opens in spite of its tripping delay set to 0.3.

Fault 2.

Circuit breakers A and B detect the fault. Circuit breaker A receives a signal from B and remains closed for the full duration of its tripping delay set to 0.3. Circuit breaker B does not receive a signal from downstream and opens immediately, in spite of its tripping delay set to 0.2.

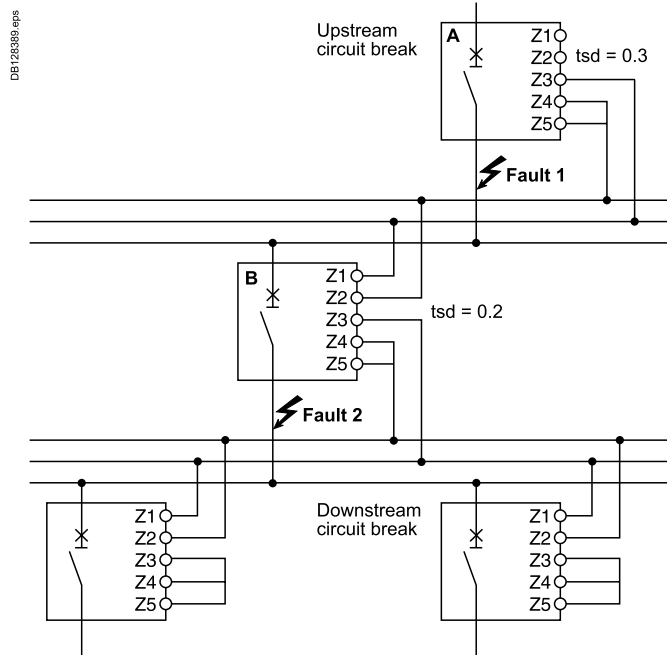

Wiring

- Maximum impedance: 2.7 Ω / 300 m.
- Capacity of connectors: 0.4 to 2.5 mm².
- Wires: single or multicore.
- Maximum length: 3000 m.
- Limits to device interconnection:
 - the common ZSI - OUT (Z1) and the output ZSI - OUT (Z2) can be connected to a maximum of 10 upstream devices
 - a maximum of 100 downstream devices may be connected to the common ZSI - IN (Z3) and to an input ZSI - IN CR (Z4) or GF (Z5).