

Command Mode Selection and Priorities

The diagram below illustrates the control inputs and selection logic which determine the source of the drive's start/stop and speed reference commands.

Command and Reference Switching

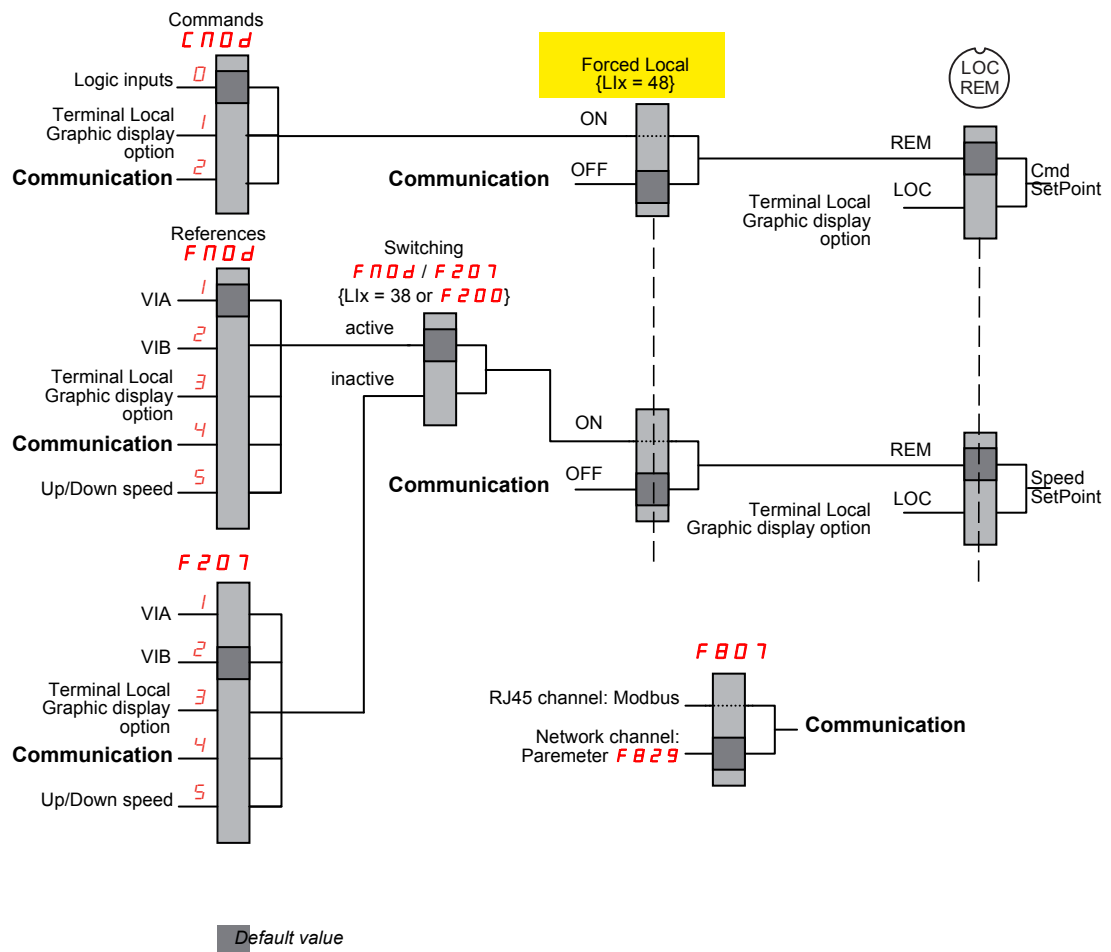

Parameters [\[Command mode sel\] \(CND\)](#) and [\[Frequency mode sel\] \(FND\)](#) are the first layers of logic used by the drive to determine its command [CND](#) and speed reference [FND](#) source.

[\[Remote spd ref 2\] \(F207\)](#) is a secondary speed reference source that may override the source selected by [FND](#) (see page 87).

The speed reference source identified by [F207](#) takes control if either:

- A logic input assigned to function 38 (frequency reference source switching) is enabled, or
- Parameter [\[Auto/man speed ref\] \(F200\)](#) is set to 1 and the drive's output frequency is equal to or less than 1 Hz (see page 118).

If a serial communication link is established, it can take control of the ATV212 drive, overriding inputs identified by [CND](#), [FND](#), and [F207](#). Control is restored to [CND](#), [FND](#), and [F207](#) only if:

- The serial communication link relinquishes control, or
- A logic input assigned to function 48 (forced local) is enabled.

The final layer of logic used by the drive to determine its command source is the LOC/REM key on the graphic display option.

When the drive and embedded HMI is set to local mode (by pressing the LOC/REM key, lighting the local mode LED), the drive responds only to commands from the embedded and graphic display option.