

# VIO

## VAM I/O units

### User Manual

VIO/en M/C006  
03/2020





# Table of Contents

1 About this manual.....	9
1.1 Purpose.....	9
1.2 Abbreviations and terms.....	9
2 Main properties.....	10
3 User interface.....	11
3.1 VAM 3LSE fiber sensor I/O unit.....	11
3.2 VAM 3LXSE fiber sensor I/O unit.....	12
3.3 VAM 10LSE point sensor I/O unit.....	13
3.4 VAM 10LDSE point sensor I/O unit.....	14
3.5 VAM 12LSE point sensor I/O unit.....	15
3.6 VAM 12LDSE point sensor I/O unit.....	17
3.7 VAM 4CSE current I/O unit.....	18
3.8 VAM 4CRL current I/O unit.....	19
3.9 VAM 4CDSE current I/O unit.....	20
3.10 VAMP 4RSE trip multiplier relay.....	21
4 Programming switches.....	22
4.1 Switches for arc sensor I/O units.....	22
4.1.1 VAM 10LSE / VAM 10LDSE, VAM 3LSE / VAM 3LXSE.....	23
4.1.2 VAM 12LSE / VAM 12LDSE.....	24
4.2 Switches for current I/O units.....	24
5 Adjusting the overcurrent setting.....	27
6 BI/BO connection.....	28
7 Connections.....	29
7.1 VAM 3LSE / VAM 3LXSE interfaces.....	30
7.2 VAM 10LSE interfaces.....	31
7.3 VAM 10LDSE interfaces.....	33
7.4 VAM 12LSE interfaces.....	34
7.5 VAM 12LDSE interfaces.....	36
7.6 VAM 4CSE interfaces.....	37
7.7 VAM 4CRL interfaces.....	39
7.8 VAM 4CDSE interfaces.....	40
7.9 VAMP 4RSE interfaces.....	41
8 I/O Technical data.....	43
8.1 Connections.....	43
8.2 Auxiliary power supply.....	44
8.3 Digital inputs.....	44
8.4 Trip contacts.....	46
8.5 Environmental conditions.....	47

8.6 Package.....	47
8.7 Disturbance tests.....	47
8.8 Electrical safety tests.....	48
8.9 Environmental tests.....	49
8.10 Casing.....	49
<b>9 Construction.....</b>	<b>51</b>
9.1 Dimensional drawings.....	51
9.1.1 VAM 3LSE / 3LXSE DIN rail mounting.....	51
9.1.2 VAM 10LSE DIN rail mounting.....	52
9.1.3 VAM 10LDSE Flush mounting.....	53
9.1.4 VAM 12LSE DIN rail mounting.....	54
9.1.5 VAM 12LDSE Flush mounting.....	55
9.1.6 VAM 4CSE / 4CRL DIN rail mounting.....	55
9.1.7 VAM 4CDSE Flush mounting.....	57
9.1.8 VAMP 4RSE DIN rail mounting.....	58
9.1.9 VA 1 DA.....	59
9.1.10 VA 1 EH.....	59
9.1.11 VYX 001.....	60
9.1.12 VYX 002.....	60
9.2 I/O unit mounting and wiring.....	61
9.2.1 VAM 10LSE, VAM 12LSE, VAM 4CSE, VAM 4CRL, VAM 3LSE, VAM 3LXSE.....	62
9.2.2 VAM 10LDSE, VAM 12LDSE, VAM 4CDSE.....	62
9.3 Connecting the VAMP 321 I/O units.....	62
9.4 Connecting the secondary circuits of the current transformers (VAM 4CSE / VAM 4CDSE / VAM 4CRL only).....	63
9.5 Connecting the trip circuits of the circuit breakers.....	64
9.6 Connecting the central unit to the I/O unit.....	64
9.7 Connecting separate auxiliary supplies.....	65
9.8 Connecting VAMP 4RSE.....	67
9.9 Wiring multiple central units.....	68
9.10 Arc sensors.....	68
9.10.1 VA 1 DA arc flash sensor.....	69
9.10.1.1 Mounting the sensors to the switchgear.....	71
9.10.1.2 Connecting the sensors to the device.....	73
9.10.2 VA 1 EH.....	74
9.10.3 ARC-SLx.....	74
9.10.4 VA 1 DP.....	75
<b>10 Order information.....</b>	<b>77</b>

## Legal information

The Schneider Electric brand and any registered trademarks of Schneider Electric Industries SAS referred to in this guide are the sole property of Schneider Electric SA and its subsidiaries. They may not be used for any purpose without the owner's permission, given in writing. This guide and its content are protected, within the meaning of the French intellectual property code (Code de la propriété intellectuelle français, referred to hereafter as "the Code"), under the laws of copyright covering texts, drawings and models, as well as by trademark law. You agree not to reproduce, other than for your own personal, noncommercial use as defined in the Code, all or part of this guide on any medium whatsoever without Schneider Electric's permission, given in writing. You also agree not to establish any hypertext links to this guide or its content. Schneider Electric does not grant any right or license for the personal and noncommercial use of the guide or its content, except for a non-exclusive license to consult it on an "as is" basis, at your own risk. All other rights are reserved.

Electrical equipment should be installed, operated, serviced and maintained only by qualified personnel. No responsibility is assumed by Schneider Electric for any consequences arising out of the use of this material.

As standards, specifications and designs change from time to time, please ask for confirmation of the information given in this publication.

# Safety information

## Important information

Read these instructions carefully and look at the equipment to become familiar with the device before trying to install, operate, service or maintain it.

The following special messages may appear throughout this publication or on the equipment to warn of potential hazards or to call attention to information that clarifies or simplifies a procedure.



This is the safety alert symbol. It is used to alert you to potential personal injury hazards. Obey all safety messages that follow this symbol to avoid possible injury or death.



The addition of either symbol to a “Danger” or “Warning” safety label indicates that an electrical hazard exists which will result in personal injury if the instructions are not followed.

### **⚠ DANGER**

**DANGER** indicates a hazardous situation which, if not avoided, **will result in death or serious injury**.

### **⚠ WARNING**

**WARNING** indicates a hazardous situation which, if not avoided, **could result in death or serious injury**.

### **⚠ CAUTION**

**CAUTION** indicates a hazardous situation which, if not avoided, **could result in minor or moderate injury**.

### **NOTICE**

**NOTICE** is used to address practices not related to physical injury.

## Please note

Electrical equipment must only be installed, operated, serviced, and maintained by qualified personnel. A qualified person is one who has skills and knowledge related to the construction, installation, and operation of electrical equipment and has received safety training to recognize and avoid the hazards involved.

No responsibility is assumed by Schneider Electric for any consequences arising out of the use of this material.

**Protective grounding**

The user is responsible for compliance with all the existing international and national electrical codes concerning protective grounding of any device.

# EU directive compliance

## EMC compliance

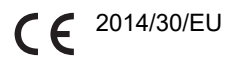

Compliance with the European Commission's EMC Directive. Product Specific Standard was used to establish conformity:

- EN 60255-26 2013

## Product safety

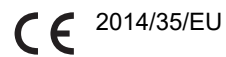

Compliance with the European Commission's Low Voltage Directive. Product Specific Safety Standard was used to establish conformity:

- EN 60255-27 2014

# 1 About this manual

## 1.1 Purpose

This manual contains a functional description of the VAM I/O units and technical data.

**NOTE:** For applications in the US, Canada and Mexico, use specific documents reviewed in line with the requirements of the relevant regulatory authorities. Contact your local Schneider Electric office for assistance.

## 1.2 Abbreviations and terms

Table 1 - Abbreviations and terms

Term	Description
BI	Binary input
BO	Binary output
Document file	Stores information about the IED settings, events and fault logs.
FPGA	Field-programmable gate array
HMI	Human-machine interface
IED	Intelligent electronic device
LCD	Liquid crystal display
LED	Light-emitting diode
Local HMI	IED front panel with display and push-buttons
PC	Personal computer
VAMPSET	Configuration tool for VAMP protection devices

## 2 Main properties

Arc flash protection system is a modular system consisting of a central unit, I/O units and arc sensors. The main purpose of the VAM I/O units is to detect arc light or short circuit current and deliver this information (zone information) to the arc protection central unit and the other VAM I/O units. Additionally VAM I/O units can be used for tripping appropriate circuit breakers.

Due to its modularity, the system is suitable for a range of arc protection applications, from simple systems with one central unit and one I/O unit to more complex solutions comprising several central units used for selective arc protection.

The I/O unit **VAM 10LSE / VAM 10LDSE, VAM 12LSE / VAM 12LDSE** serves as link between the system's point sensors and the central unit. Each I/O unit has connections for ten arc sensors, one portable pin sensor and one trip output.

The I/O unit **VAM 3LSE / VAM3LXSE** serves as link between the system's fibre sensors and the central unit. Each I/O unit has connections for three arc sensors, one pin sensor and one trip output.

The I/O unit **VAM 4CSE / VAM 4CDSE / VAM 4CRL** serves as link between the system's current inputs and the central unit. Each I/O unit has connections for three current transformers and one trip output.

The arc sensor **VA 1 DA** is activated by strong light. The sensor transforms the light information into the current signal, which is forwarded through the I/O unit to the central unit. The arc sensor **VA 1 EH** also operates on the same principle.

The pin sensor **VA 1 DP** has the same functions as an arc sensor but can be temporarily connected to an I/O unit. The sensor can be fixed to the breast pocket of a technician to improve safety when working with live switchgear.

**The door mounted** VAM I/O units with the letter D in the type designations VAM 10LDSE, VAM 12LDSE and VAM 4CDSE are door mounted versions for the corresponding VAM 10LSE, VAM 12LSE and VAM 4CSE units. The functionality is exactly the same.

## 3 User interface

Usually, there is no need to use the front panel during normal operation, since all the necessary information can be read from the central unit display. However, after a new installation or a system expand you will need to program certain functions (zone/address, trip output) in the I/O unit.

**NOTE:** If you unfasten the terminal blocks during installation, remember to tighten the fixing screws after installation! Also tighten the screws even if you did not unfasten the blocks.

I/O units include a LED test function. When devices are powered up, all units latch the front panel indications for a few seconds.

### 3.1 VAM 3LSE fiber sensor I/O unit

Figure 1 - VAM 3LSE fiber sensor I/O unit front panel

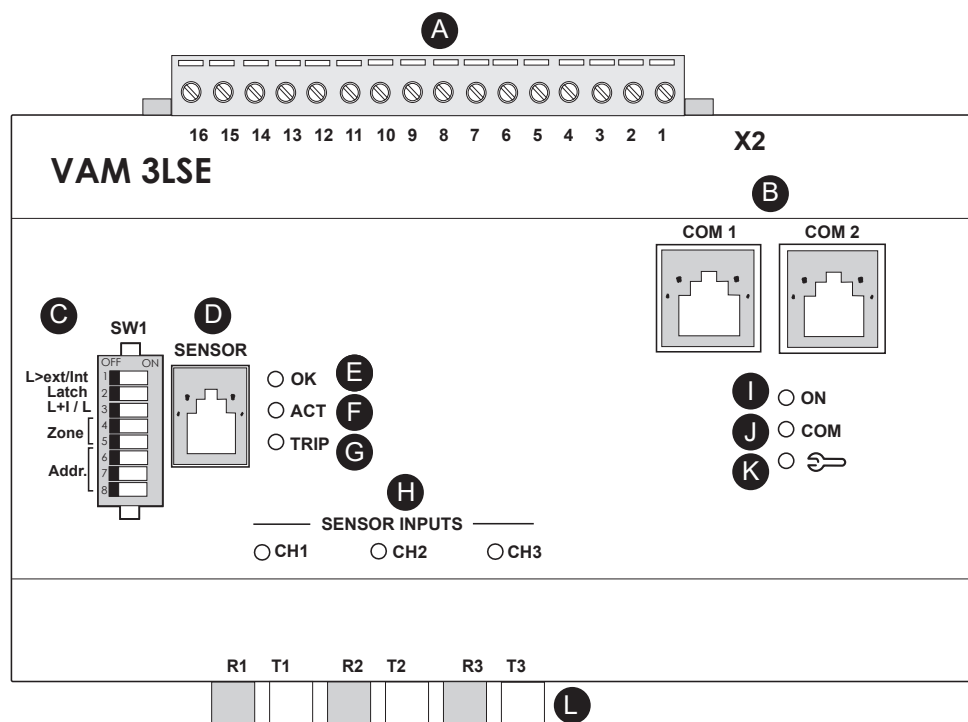

- A.** Terminal block for external communication and BI/O channels and trip signal
- B.** Connector sockets for the VX001 modular cables
- C.** Programming switches
- D.** Connection for portable arc sensor (VA 1 DP)
- E.** Portable arc sensor VA 1 DP connected and operational
- F.** Portable arc sensor activated
- G.** I/O unit trip relay activated
- H.** LED lights indicating sensor activation
- I.** Power indicator light, indicates that the supply voltages of each component are in order
- J.** COM indicator light, lit when the central units and I/O units are communicating

**K.** Error indicator light, indicates an internal fault (for example, faulty arc sensor or changes in the amount of sensors) detected by the component's self-diagnostics

**L.** Terminals for three fibre sensors

## 3.2 VAM 3LXSE fiber sensor I/O unit

Figure 2 - VAM 3LXSE fiber sensor I/O unit front panel

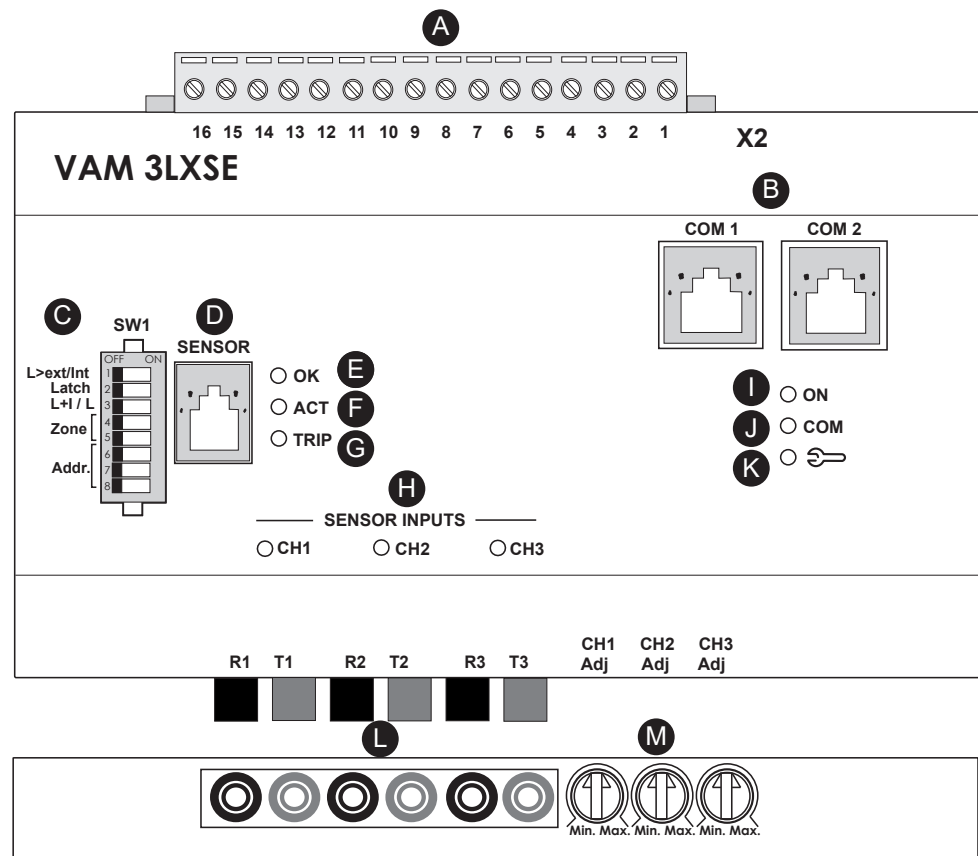

**A.** Terminal block for external communication and BI/O channels and trip signal

**B.** Connector sockets for the VX001 modular cables

**C.** Programming switches

**D.** Connection for portable arc sensor (VA 1 DP)

**E.** Portable arc sensor VA 1 DP connected and operational

**F.** Portable arc sensor activated

**G.** I/O unit trip relay activated

**H.** LED lights indicating sensor activation

**I.** Power indicator light, indicates that the supply voltages of each component are in order.

**J.** COM indicator light, lit when the central units and I/O units are communicating

**K.** Error indicator light, indicates an internal fault (for example, faulty arc sensor or changes in the amount of sensors) detected by the component's self-diagnostics

- L. Terminals for three fibre sensors
- M. Sensitivity adjustments for each fibre sensor channels

### 3.3 VAM 10LSE point sensor I/O unit

Figure 3 - VAM 10LSE point sensor I/O unit front panel

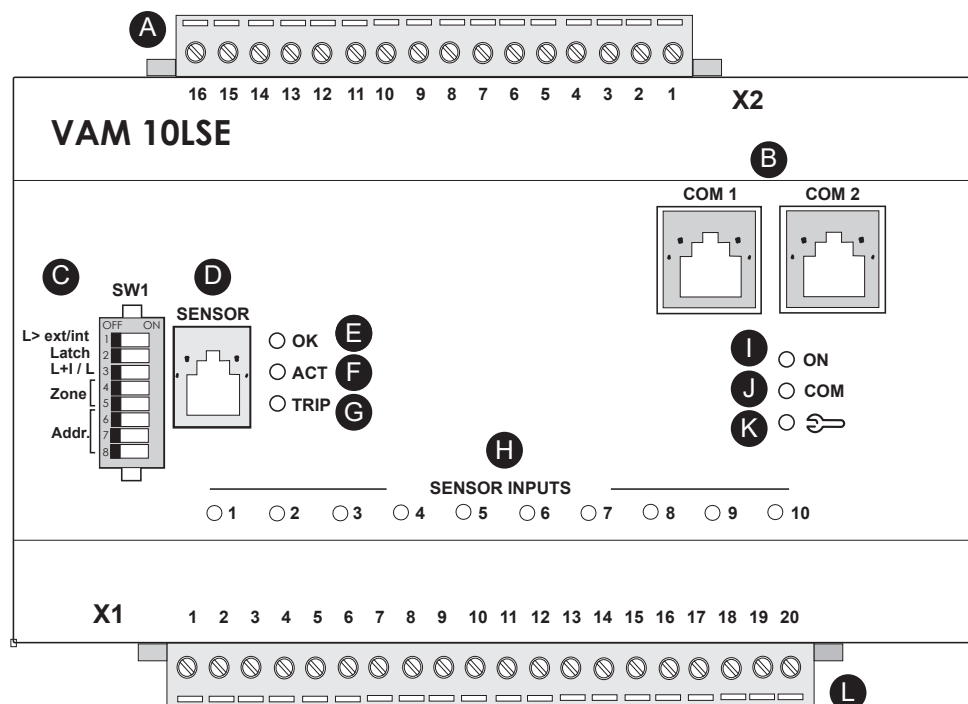

- A. Terminal block for external communication and BI/O channels and trip signal
- B. Connector sockets for the VX001 modular cables
- C. Programming switches
- D. Connection for portable arc sensor (VA 1 DP)
- E. Portable arc sensor VA 1 DP connected and operational
- F. Portable arc sensor activated
- G. I/O unit trip relay activated
- H. LED lights indicating sensor activation
- I. Power indicator light, indicates that the supply voltages of each component are in order.
- J. COM indicator light, lit when the central units and I/O units are communicating
- K. Error indicator light, indicates an internal fault (for example, faulty arc sensor or changes in the amount of sensors) detected by the component's self-diagnostics
- L. Terminals for three fibre sensors

### 3.4 VAM 10LDSE point sensor I/O unit

Figure 4 - VAM 10LDSE point sensor I/O unit front and back panel

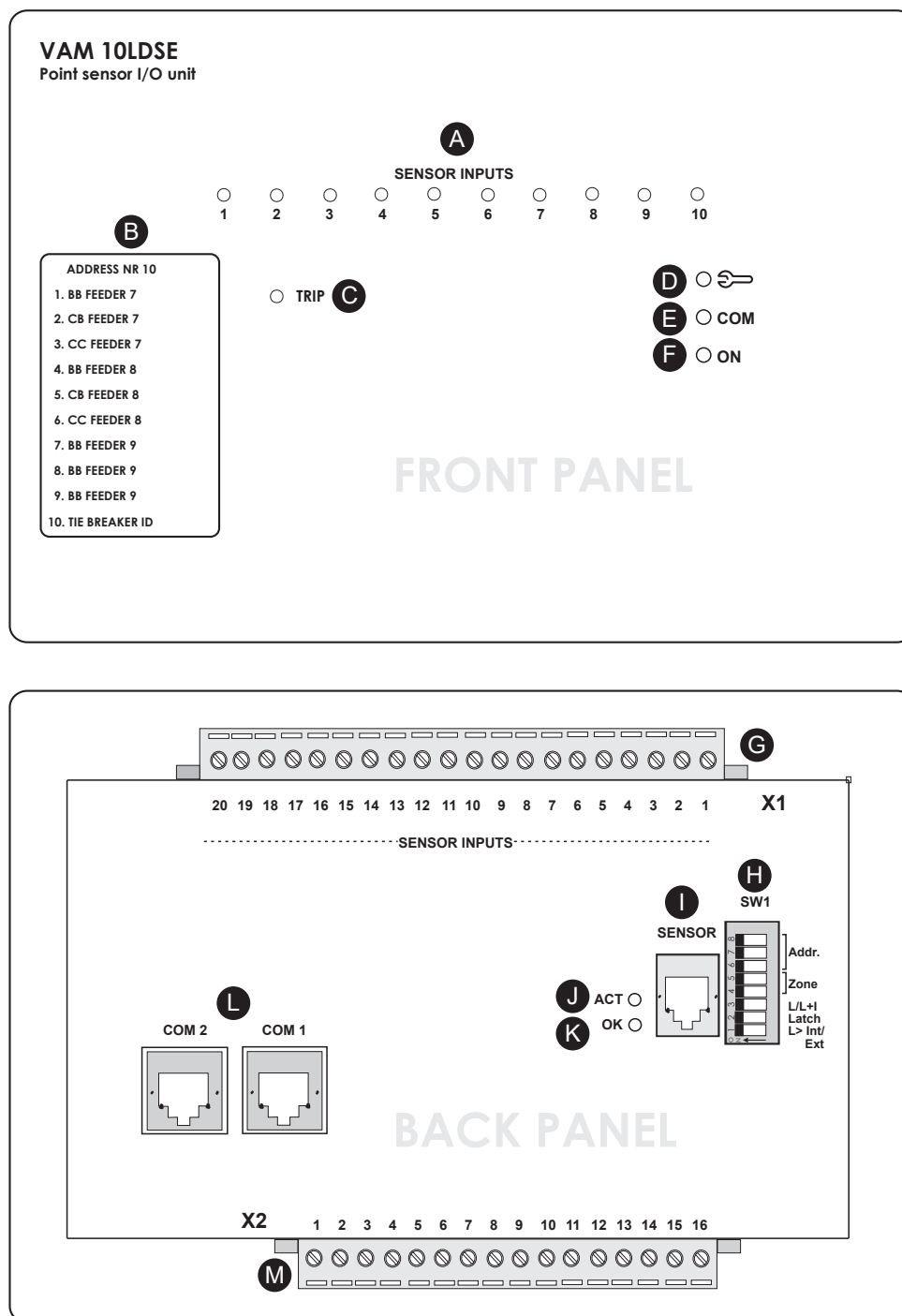

- A.** LED lights indicating sensor activation
- B.** Text pocket for sensor-specific labels
- C.** I/O unit trip relay activated
- D.** Error indicator light, indicates an internal fault (for example, faulty arc sensor or changes in the amount of sensors) detected by the component's self-diagnostics
- E.** COM indicator light, lit when the central unit and I/O units are communicating.

- F. Power indicator light, indicates that the supply voltages of each component are in order.
- G. Terminal block for ten arc sensors
- H. Programming switches
- I. Connection for portable arc sensor (VA 1 DP)
- J. Portable arc sensor activated
- K. Portable arc sensor VA 1 DP connected and operational
- L. Connector sockets for the VX001 modular cables
- M. Terminal block for external communication and BI/O channels and trip signal

### 3.5 VAM 12LSE point sensor I/O unit

VAM 12L is primary design for selective feeder trip applications. The unit comprises 3 electromechanical trip normally open contacts and one trip alarm change over contact.

The unit has 10 Arc sensor inputs. Three sensors (of the ten) inputs are dedicated, and are controlling their own trip relay. The unit is ideal for selective trip of cable compartment in case of an ARC fault. VAM 12L can selectively handle 3 feeders. The rest of the sensors can then supervise the busbar and breaker compartments and will operate in the zone selected by the unit address switches.

Figure 5 - VAM 12LSE point sensor I/O unit front panel

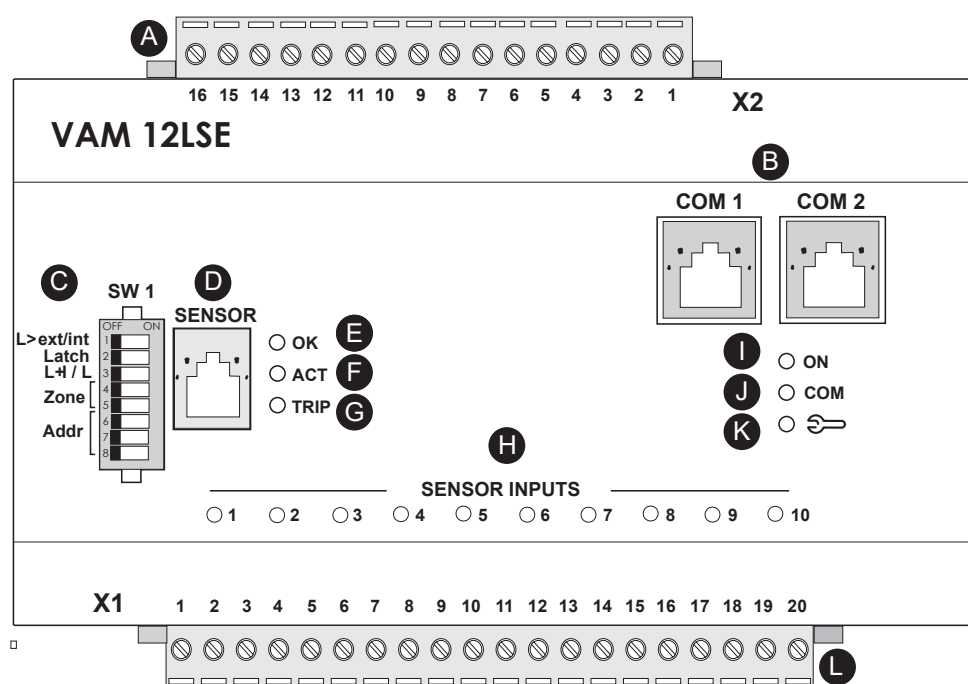

- A. Terminal block for external communication and BI/O channels and trip signal
- B. Connector sockets for the VX001 modular cables
- C. Programming switches
- D. Connection for portable arc sensor (VA 1 DP)
- E. Portable arc sensor VA 1 DP connected and operational
- F. Portable arc sensor activated

- G.** I/O unit trip relay activated
- H.** LED lights indicating sensor activation
- I.** Power indicator light, indicates that the supply voltages of each component are in order.
- J.** COM indicator light, lit when the central units and I/O units are communicating
- K.** Error indicator light, indicates an internal fault (for example, faulty arc sensor or changes in the amount of sensors) detected by the component's self-diagnostics
- L.** Terminals for three fibre sensors

### 3.6 VAM 12LDSE point sensor I/O unit

Figure 6 - VAM 12LDSE point sensor I/O unit front and back panel

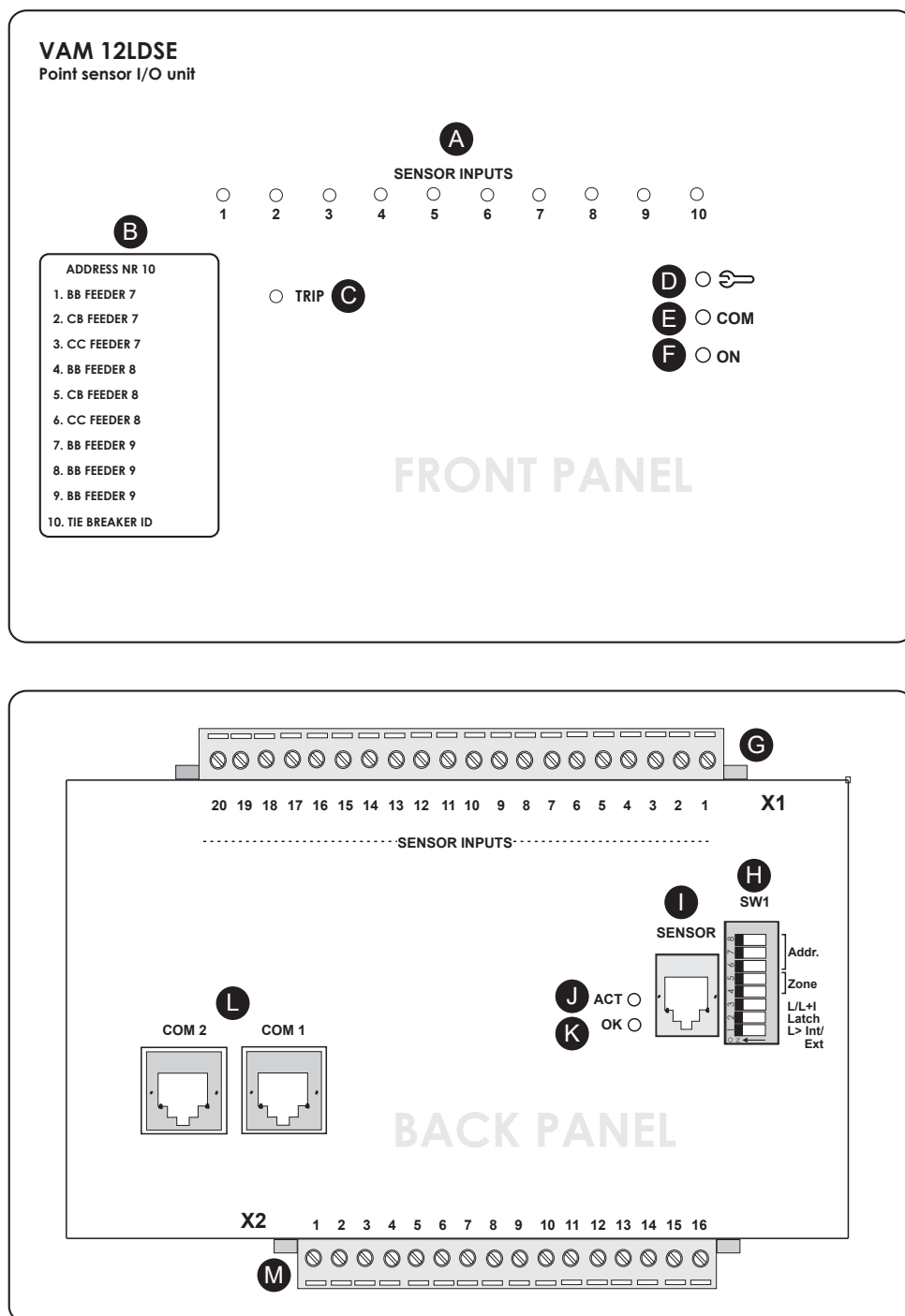

- A. LED lights indicating sensor activation
- B. Text pocket for sensor-specific labels
- C. I/O unit trip relays activated
- D. Error indicator light, indicates an internal fault detected by the component's self-diagnostics. Such faults include faulty arc sensor or changes in the amount of sensors.
- E. COM indicator light, lit when the central unit and I/O units are communicating.

- F. Power indicator light, indicates that the supply voltages of each component are in order.
- G. Terminal block for ten arc sensors
- H. Programming switches
- I. Connection for portable arc sensor (VA 1 DP)
- J. Portable arc sensor activated
- K. Portable arc sensor VA 1 DP connected and operational
- L. Connector sockets for the VX001 modular cables
- M. Terminal block for output relays

### 3.7 VAM 4CSE current I/O unit

Figure 7 - VAM 4CSE current I/O unit front panel

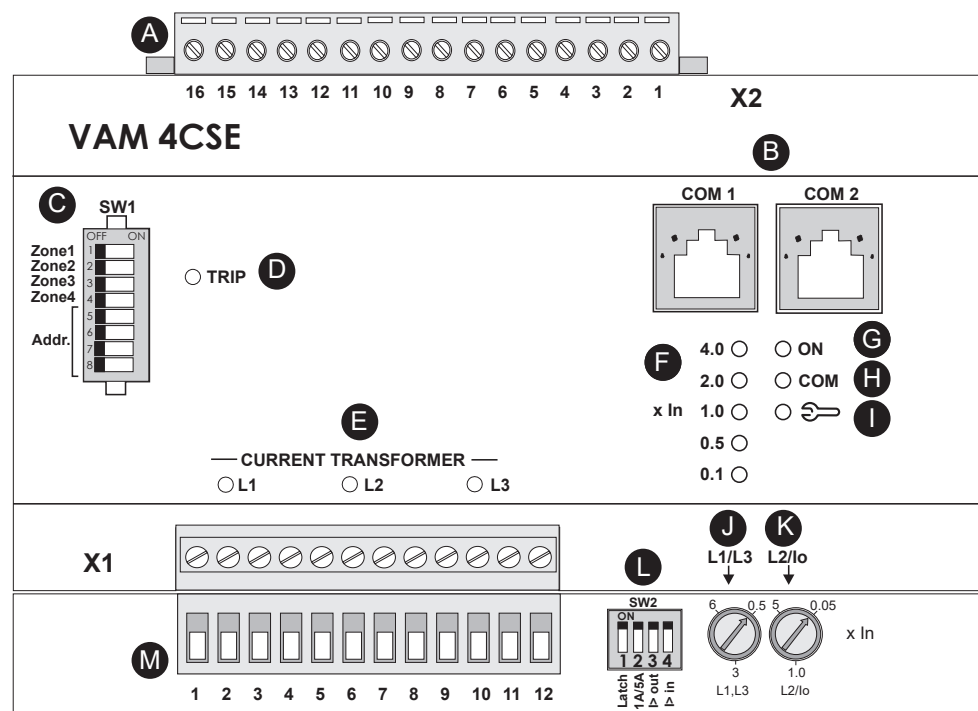

- A. Terminal block for external communication and BI/O channels and trip signal
- B. Connector sockets for the VX001 modular cables
- C. Programming switches
- D. I/O unit trip relay activated
- E. LED lights indicating that I> stage has started
- F. Indicator LEDs for current setting
- G. Power indicator light, indicates the supply voltages of each component are in order.
- H. COM indicator light, lit when the central units and I/O units are communicating.
- I. Error indicator light, indicates an internal fault detected by the component's self-diagnostics. Such faults include faulty current transformer or phase current unbalance.
- J. Overcurrent setting knob ( $I_{L1}$ ,  $I_{L3}$ ), setting range 0.5–6 x  $I_N$

**K.** Overcurrent setting knob ( $I_{L1}$ ,  $I_o$ ), setting range  $0.05\text{--}5 \times I_N$

**L.** Current transformer programming switches

**M.** Terminals for three current transformers

## 3.8 VAM 4CRL current I/O unit

Figure 8 - VAM 4CRL current I/O unit front panel

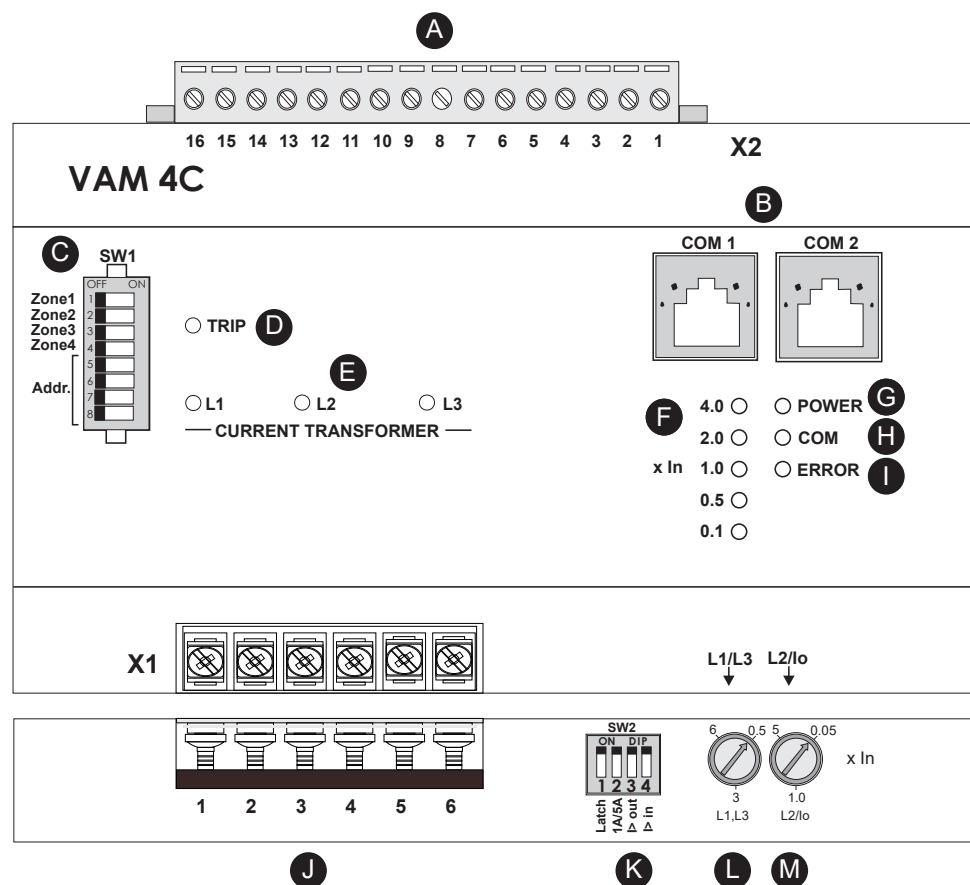

**A.** Terminal block for external communication and BI/O channels and trip signal

**B.** Connector sockets for the VX001 modular cables

**C.** Programming switches

**D.** I/O unit trip relay activated

**E.** LED lights indicating that  $I >$  stage has started

**F.** Indicator LEDs for current setting

**G.** Power indicator light, indicates the supply voltages of each component are in order.

**H.** COM indicator light, lit when the central units and I/O units are communicating.

**I.** Error indicator light, indicates an internal fault detected by the component's self-diagnostics. Such faults include faulty current transformer or phase current unbalance.

**J.** Terminals for three current transformers

**K.** Current transformer programming switches

- L. Overcurrent setting knob ( $I_{L1}$ ,  $I_{L3}$ ), setting range  $0.5-6 \times I_N$
- M. Overcurrent setting knob ( $I_{L2}$ ,  $I_0$ ), setting range  $0.05-5 \times I_N$

### 3.9 VAM 4CDSE current I/O unit

Figure 9 - VAM 4CDSE current I/O unit front and back panel

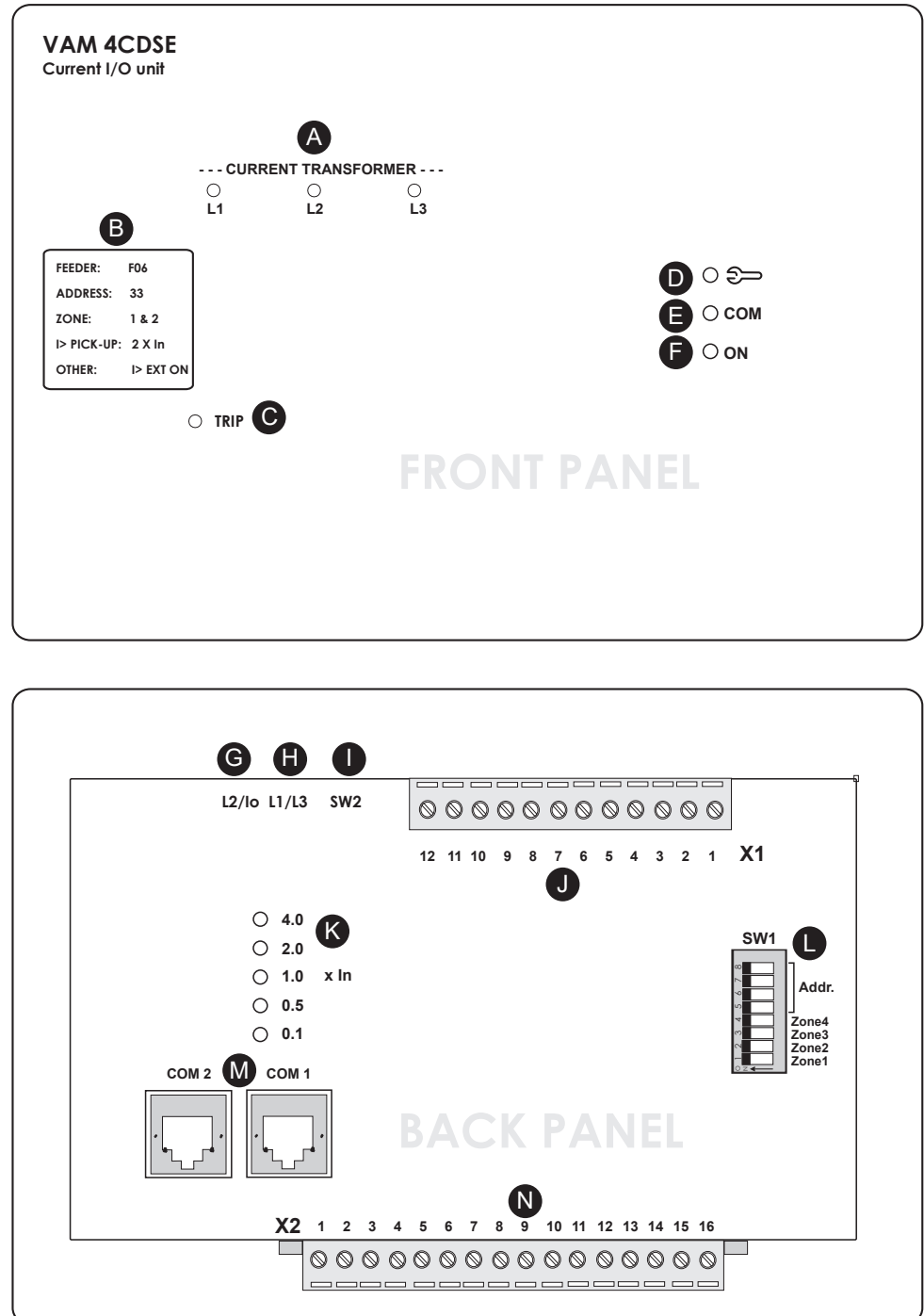

- A. LED lights indicating that I> stage has started
- B. Text pocket
- C. I/O unit trip relay activated

- D.** Error indicator light, indicates an internal fault (for example, faulty current transformer or phase current unbalance) detected by the component's self-diagnostics
- E.** COM indicator light, lit when the central units and I/O units are communicating.
- F.** Power indicator light, indicates the supply voltages of each component are in order.
- G.** Overcurrent setting knob ( $I_{L2}$ ,  $I_0$ ), setting range  $0.05\text{--}5 \times I_N$
- H.** Overcurrent setting knob ( $I_{L1}$ ,  $I_{L3}$ ), setting range  $0.5\text{--}6 \times I_N$
- I.** Current transformer programming switches
- J.** Terminals for three current transformers
- K.** Text pocket
- L.** Programming switches
- M.** Connector sockets for the VX001 modular cables
- N.** Terminal block for external communication and BI/O channels and trip signal

### 3.10 VAMP 4RSE trip multiplier relay

Figure 10 - VAMP 4RSE trip multiplier relay front panel

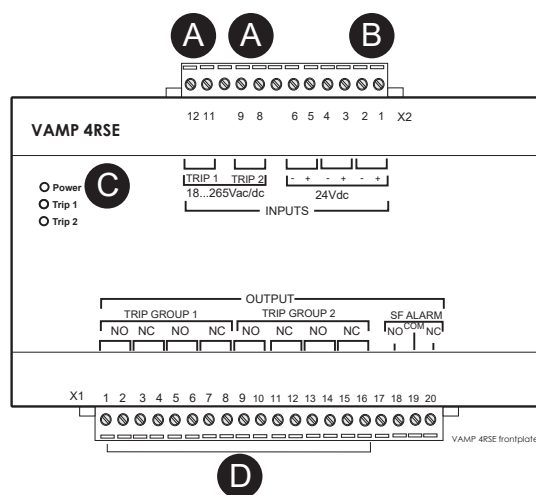

- A.** Terminals for incoming trip signal (e.g. 24 Vdc from VAM I/O unit binary output, 2 groups). Control voltage range is 18–265 Vad/dc.
- B.** Terminals for external operating voltage (+24 Vdc). Can be supplied by central units or I/O units.
- C.** Power LED, indicates that the external operating voltage of +24 Vdc is connected.
- D.** Terminals for outgoing trip signals (8 potential-free contacts, 4 normally open, 4 normally closed).

## 4 Programming switches

Before system implementation, check the positions of the programming switches in accordance with the following basic principles:

- Each I/O unit connected to the communication bus has its own address (each I/O unit have an unique address).
- Set the programming switches before connecting the supply voltage.
- If you have to change the switch positions once the supply voltage has been connected, disconnect the supply voltage to the unit in question for the duration of the programming and re-configure the system.
- If position of the switch is changed, re-install the system again in the central unit.

### 4.1 Switches for arc sensor I/O units

The programming switches of the I/O units are used to determine the unit address and trip relay function.

The system accommodates up to 16 units including possible central units in master or slave mode.

Eight addresses are reserved for each protection zone:

- **Zone 1** addresses 0–7
- **Zone 2** addresses 8–15
- **Zone 3** addresses 16–23
- **Zone 4** addresses 24–31

The programming switches have different weight factors. To create an address for the I/O unit, turn switches with different values to the ON position and calculate the sum of their weight factors. The following table shows the weight factors of each programming switch.

Table 2 - Programming switch weight factors

Switch No.	Weight factor
8	1
7	2
6	4
5	8
4 <sup>1</sup>	16

<sup>1</sup> VAM 10LSE / VAM 10LDSE, VAM 12LSE / VAM 12LDSE, and VAM 3LSE / VAM 3LXSE only

**NOTE:** Note the position of the VAM 12LDSE, VAM 10LDSE and VAM 4CDSE dip switches.

Figure 11 - Programming switches for VAM 10LSE, VAM 10LDSE, VAM 12LSE, VAM 12LDSE, VAM 3LSE and VAM 3LXSE

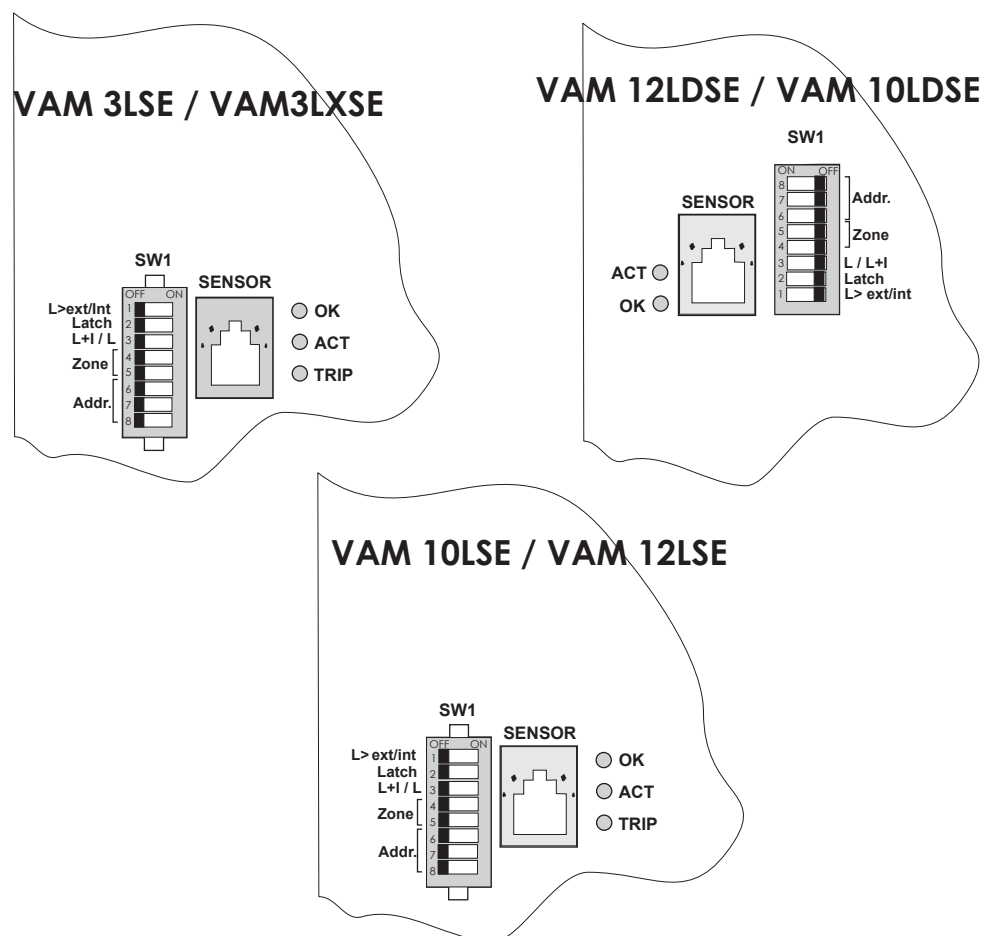

### 4.1.1 VAM 10LSE / VAM 10LDSE, VAM 3LSE / VAM 3LXSE

**Switch 1** determines which light activation activates the arc stage. When the switch position is ON, the arc stage only activates on the light information provided by the unit's own sensors. In OFF position the arc stage activates on the light information received from any unit in the same protection zone.

**Switch 2** determines the trip relay latch. When the switch is in ON position the trip relay remains engaged after the arc trip until the fault is acknowledged at the central unit's panel. In the OFF position the trip relay follows the arc fault.

**Switch 3** determines the arc trip criteria. When the switch is in ON position the trip is based on light information only; in OFF position both fault currents exceeding the current limit and light information are required.

## 4.1.2 VAM 12LSE / VAM 12LDSE

Table 3 - Behavior of the output relays

		Output relays				Zone output
		Trip 1	Trip 2	Trip 3	Alarm	
L>ext/int dip in ON POSITION	Sensor 1	x	-	-	x	-
	Sensor 2	-	x	-	x	-
	Sensor 3	-	-	x	x	-
	Sensor 4-10	-	-	-	-	x
	Zone activation	-	-	-	-	-
L>ext/int dip in OFF POSITION	Sensor 1	x	-	-	x	-
	Sensor 2	-	x	-	x	-
	Sensor 3	-	-	x	x	-
	Sensor 4-10	x	x	x	x	x
	Zone activation	x	x	x	x	-

When the L>ext/int DIP switch is in “L>int” position, the output relays are only activated by dedicated sensors.

- **SENSOR 1** activates T1.
- **SENSOR 2** activates T2.
- **SENSOR 3** activates T3.
- **SENSORS 4 to 10** are normally sending light information to system according to zone setting.

If the switch is in “L>ext” position, all output relays are also controlled by the selected zone information. This activation source can be any sensor channel 4 to 10 or from an external I/O unit configured to the same zone.

**NOTE:** The L>ext/int dip’s position is indicated as it is found on the switch, not by the markings on the front panel.

## 4.2 Switches for current I/O units

The address range for current I/O units is (32), 33–47. To determine the address of a current I/O unit, add the sum of the weight factors to 32 (for example, programming switch values total 7, address of the current I/O unit  $32 + 7 = 39$ ).

**NOTE:** Do not configure address 32 for the VAM 4Cx unit because 32 is reserved for the master unit of the arc flash protection system.

Other programming switches have different functions in different units, as described below.

**VAM 4CSE / VAM 4CDSE / VAM 4CRL**

Figure 12 - Programming switches of VAM 4CSE / VAM 4CDSE / VAM 4CRL

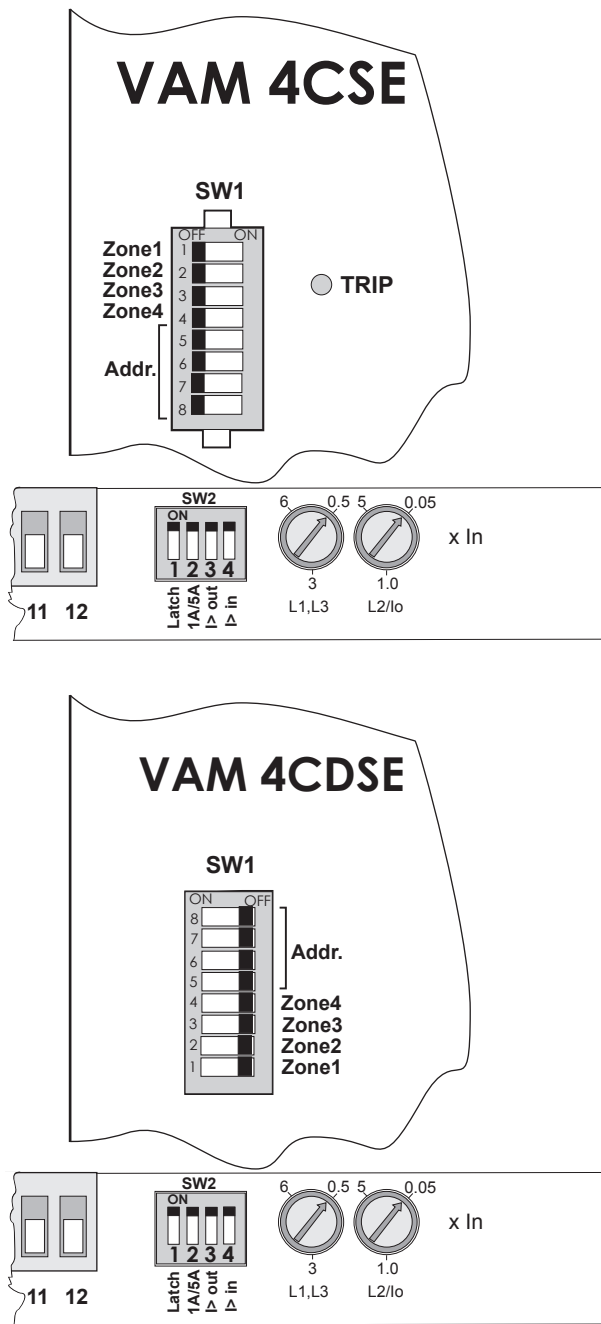

Table 4 - VAM 4CSE / VAM 4CDSE / VAM 4CRL DIP switches weight factors

Switch No.	Weight factor
8	1
7	2

Switch No.	Weight factor
6	4
5	8

Table 5 - SW1 switch settings

Switch	Definition	Description
1	Zone 1	System operating zone 1 (light information)
2	Zone 2	System operating zone 2 (light information)
3	Zone 3	System operating zone 3 (light information)
4	Zone 4	System operating zone 4 (light information)
5	Addr	Address weighting coefficient 8
6	Addr	Address weighting coefficient 4
7	Addr	Address weighting coefficient 2
8	Addr	Address weighting coefficient 1

Table 6 - SW2 switch settings

Switch	Definition	Description
1	Latch	Position "0" (switch down): trip relay is only operational while the protection is activated Position "1" (switch up): trip relay changes to latching status after trip
2	1A / 5A <sup>2</sup>	Position "0" (switch down): rated secondary current of the current transformer is 1 A Position "1" (switch up): rated secondary current of the current transformer is 5 A
3	I> out	Position "0" (switch down): unit does not transmit the current criteria to other units Position "1" (switch up): unit transmits the current criteria to other units
4	I> in	Position "0" (switch down): unit does not receive the current criteria from other units Position "1" (switch up): unit receives the current criteria from other units

<sup>2</sup> As in CT

## 5 Adjusting the overcurrent setting

The principles for changing the current setting in VAM 4CSE / VAM 4CDSE / VAM 4CRL units are the same as for the central unit. You can see the estimated current setting from the LED bar on the right side of the unit.

The most accurate way of setting the current limit for the unit is as follows:

1. Turn the potentiometer to the maximum value.
2. Feed a test current corresponding to the required setting using a testing device.
3. Lower the setting until the current activation indicator LED of the I/O unit and / or the I>ext indicator LED in VAMP 221 the central unit are / is lit.

Figure 13 - Example of adjusting the current setting in VAM 4CSE

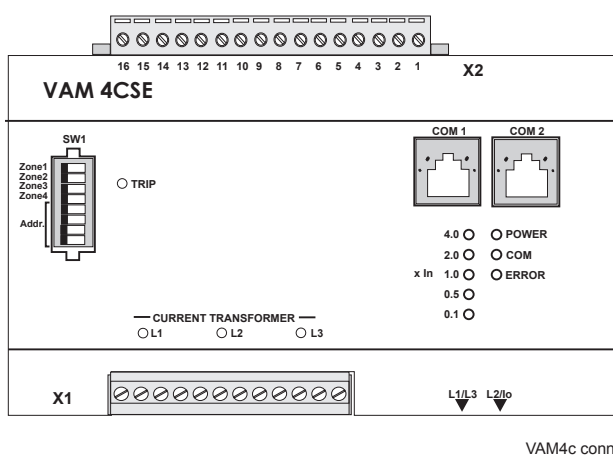

## 6 BI/BO connection

Each I/O unit also has a BI/O bus. The light I/O units (VAM 10LSE / VAM 10LDSE, VAM 12LSE / VAM 12LDSE, VAM 3LSE / VAM 3LXSE) can transmit trip signal to the central unit or current I/O unit. The current I/O unit (VAM 4CSE / VAM 4CDSE / VAM 4CRL) can receive the light information and send the current information either to other I/O units or the multiplying relay.

**NOTE:** The DI/DO on the VAM units are fast BI/BO signals.

Table 7 - DI and DO connections in the standard delivery of VAM 10LSE and VAM 3LSE / VAM 3LXSE

DI	X2-8	Zone shift 1(2, 2(1, 3(4, 4(3
GND	X2-7	
Trip out	X2-10	Trip signal, 24 V dc
GND	X2-9	Trip signal earth

Table 8 - DI and DO connections in the standard delivery of VAM 4CSE / VAM 4CDSE / VAM 4CRL units

L>in	X2-8	Light input, 24–48 V dc
GND	X2-7	Light input earth
Trip out	X2-10	Trip signal
GND	GND	Trip signal earth

**NOTE:** L>in light input in VAM 4CSE / VAM 4CDSE / VAM 4CRL (X2-7 & X2-8) is master light input. This means that incoming light zone dip switch settings do not matter and unit trips when this input is active and there is current over the set limit.

## 7 Connections

Ground the VAM I/O units according to the *Construction* chapter of this document.

### **DANGER**

#### **HAZARD OF ELECTRIC SHOCK, EXPLOSION, OR ARC FLASH**

- Apply appropriate personal protective equipment (PPE) and follow safe electrical work practices. See NFPA 70E, NOM-029-STPS-2011, or CSA Z462.
- The arc fault detection system is not a substitute for proper PPE when working on or near equipment being monitored by the system.
- Information on this product is offered as a tool for conducting arc flash hazard analysis. It is intended for use only by qualified persons who are knowledgeable about power system studies, power distribution equipment, and equipment installation practices. It is not intended as a substitute for the engineering judgement and adequate review necessary for such activities.
- Only qualified personnel should install and service this equipment. Read this entire set of instructions and check the technical characteristics of the device before performing such work.
- Perform wiring according to national standards (NEC) and any requirements specified by the customer.
- Observe any separately marked notes and warnings.
- NEVER work alone.
- Before performing visual inspections, tests, or maintenance on this equipment, disconnect all sources of electric power. Assume all circuits are live until they are completely de-energized, tested, and tagged. Pay particular attention to the design of the power system. Consider all sources of power, including the possibility of backfeeding.
- Always use a properly rated voltage sensing relay to ensure that all power is off.
- The equipment must be grounded.
- Connect the device's protective ground to functional earth according to the connection diagrams presented in this document.
- Do not open the device. It contains no user-serviceable parts.
- Install all devices, doors and covers before turning on the power to this device.

**Failure to follow these instructions will result in death or serious injury.**

### **DANGER**

#### **HAZARD OF ELECTRIC SHOCK, EXPLOSION, OR ARC FLASH**

Always connect the grounding conductor before connecting the power supply.

**Failure to follow these instructions will result in death or serious injury.**

#### **Related topics**

[Construction](#) on page 51

## 7.1 VAM 3LSE / VAM 3LXSE interfaces

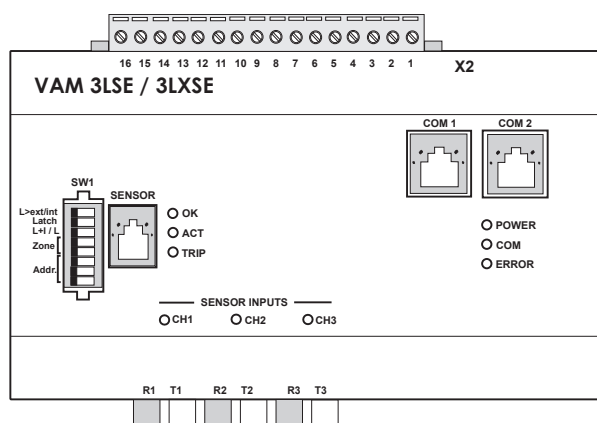

Table 9 - VAM 3LSE / VAM 3LXSE interfaces

Connector			
X1-R1:	Fiber receiver connection	Channel 1	
X1-T1:	Fiber transmitter connection		
X1-R2:	Fiber receiver connection	Channel 2	
X1-T2:	Fiber transmitter connection		
X1-R3:	Fiber receiver connection	Channel 3	
X1-T3:	Fiber transmitter connection		
X2-1:	+24V supply from master unit or external power supply		= COM1, COM2
X2-2:	GND		
X2-3:	CAN-L	Zone information (L>, L<)	
X2-4:	CAN-H		
X2-5:	Serial B	master slave com	
X2-6:	Serial A		

Connector			
X2-7:	DI GND	Zone change (1 -> 2; 2 -> 1; 3 -> 4; 4 -> 3)	
X2-8:	DI (24-48Vdc)		
X2-9:	DO GND	Trip signal (DI&DO)	
X2-10:	DO +24Vdc		
X2-11:	+ Temp sensor	Not in use	
X2-12:	- Temp sensor		
X2-13:			
X2-14:			
X2-15:	Trip relay (NO)		
X2-16:	Trip relay (NO)		

## 7.2 VAM 10LSE interfaces

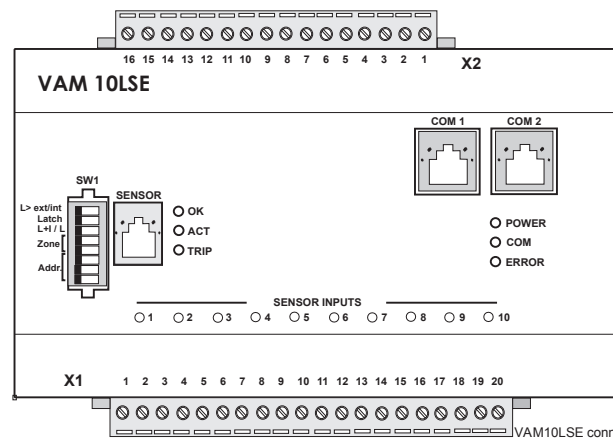

Table 10 - VAM 10LSE interfaces

Connector			
X1-1, 2:	Arc sensor channel 1		
X1-3, 4:	Arc sensor channel 2		
X1-5, 6:	Arc sensor channel 3		
X1-7, 8:	Arc sensor channel 4		

<b>Connector</b>			
X1-9, 10:	Arc sensor channel 5		
X1-11, 12:	Arc sensor channel 6		
X1-13, 14:	Arc sensor channel 7		
X1-15, 16:	Arc sensor channel 8		
X1-17, 18:	Arc sensor channel 9		
X1-19, 20:	Arc sensor channel 10		
X2-1:	+24V supply from masterunit or external power supply		=COM1, COM2
X2-2:	GND		
X2-3:	CAN-L	Zone information (L>, I>)	
X2-4:	CAN-H		
X2-5:	Serial B	Master slave com	
X2-6:	Serial A		
X2-7:	DI GND	Zone change (1 -> 2; 2 ->1; 3 -> 4; 4 -> 3)	
X2-8:	DI (24 – 48Vdc)		
X2-9:	DO GND	Trip signal	
X2-10:	DO +24Vdc		
X2-11:	+ Temp sensor	Not in use	
X2-12:	- Temp sensor		
X2-13:			
X2-14:			
X2-15:	Trip relay (NO)		
X2-16:	Trip relay (NO)		

## 7.3 VAM 10LDSE interfaces

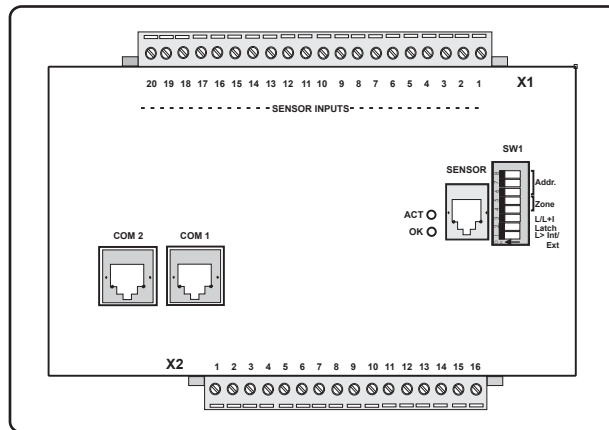

Table 11 - VAM 10LDSE interfaces

Connector			
X1-1, 2:	Arc sensor channel 1		
X1-3, 4:	Arc sensor channel 2		
X1-5, 6:	Arc sensor channel 3		
X1-7, 8:	Arc sensor channel 4		
X1-9, 10:	Arc sensor channel 5		
X1-11, 12:	Arc sensor channel 6		
X1-13, 14:	Arc sensor channel 7		
X1-15, 16:	Arc sensor channel 8		
X1-17, 18:	Arc sensor channel 9		
X1-19, 20:	Arc sensor channel 10		
X2-1:	+24V supply from masterunit or external power supply		=COM1, COM2

Connector			
X2-2:	GND		
X2-3:	CAN-L	Zone information (L>, I>)	
X2-4:	CAN-H		
X2-5:	Serial B	Master slave com	
X2-6:	Serial A		
X2-7:	DI GND	Zone change (1 -> 2; 2 ->1; 3 -> 4; 4 -> 3)	
X2-8:	DI (24-48Vdc)		
X2-9:	DO GND		
X2-10:	DO +24Vdc		
X2-11:	+ Temp sensor	Not in use	
X2-12:	- Temp sensor		
X2-13:			
X2-14:			
X2-15:	Trip relay (NO)		
X2-16:	Trip relay (NO)		

## 7.4 VAM 12LSE interfaces

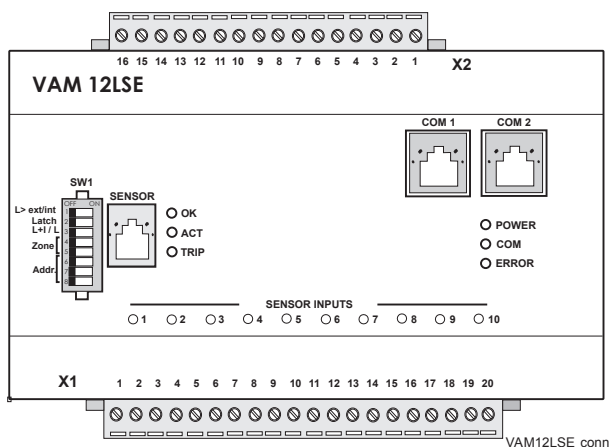

Table 12 - VAM 12LSE interfaces

Connector		
X1-1, 2:	Arc sensor channel 1	
X1-3, 4:	Arc sensor channel 2	
X1-5, 6:	Arc sensor channel 3	
X1-7, 8:	Arc sensor channel 4	
X1-9, 10:	Arc sensor channel 5	
X1-11, 12:	Arc sensor channel 6	
X1-13, 14:	Arc sensor channel 7	
X1-15, 16:	Arc sensor channel 8	
X1-17, 18:	Arc sensor channel 9	
X1-19, 20:	Arc sensor channel 10	
X2-1:	+24v supply from masterunit or external power supply	
X2-2:	GND	
X2-3:		
X2-4:	COM	Alarm
X2-5:	NO	
X2-6:	NC	
X2-7:		
X2-8:	Trip relay 3 (NO)	
X2-9:	Trip relay 3 (NO)	
X2-10:		
X2-11:	Trip relay 2 (NO)	
X2-12:	Trip relay 2 (NO)	
X2-13:		
X2-14:		
X2-15:	Trip relay 1 (NO)	
X2-16:	Trip relay 1 (NO)	

## 7.5 VAM 12LDSE interfaces

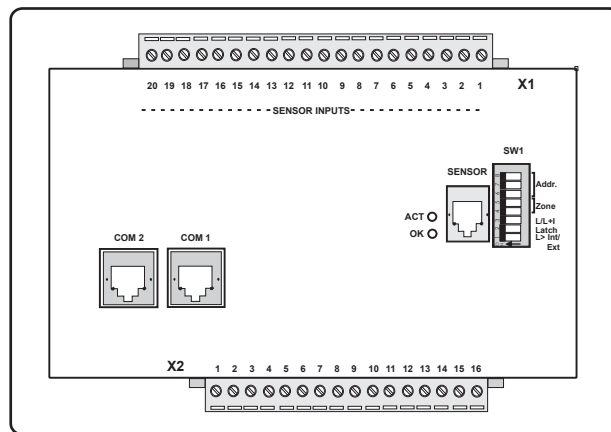
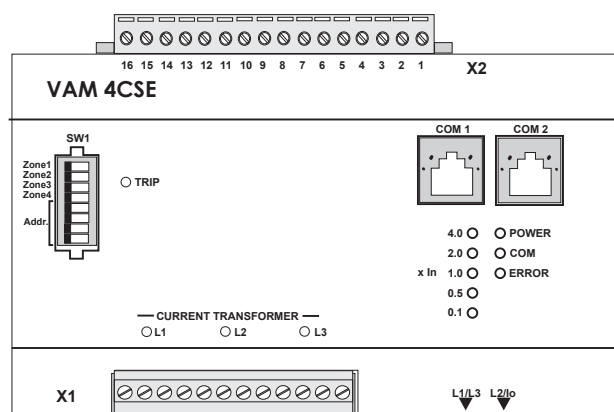

Table 13 - VAM 12LDSE interfaces

Connector			
X1-1, 2:	Arc sensor channel 1		
X1-3, 4:	Arc sensor channel 2		
X1-5, 6:	Arc sensor channel 3		
X1-7, 8:	Arc sensor channel 4		
X1-9, 10:	Arc sensor channel 5		
X1-11, 12:	Arc sensor channel 6		
X1-13, 14:	Arc sensor channel 7		
X1-15, 16:	Arc sensor channel 8		
X1-17, 18:	Arc sensor channel 9		
X1-19, 20:	Arc sensor channel 10		
X2-1:	+24v supply from masterunit or external power supply		

Connector			
X2-2:	GND		
X2-3:			
X2-4:	COM	Alarm	
X2-5:	NO		
X2-6:	NC		
X2-7:			
X2-8:	Trip relay 3 (NO)		
X2-9:	Trip relay 3 (NO)		
X2-10:			
X2-11:	Trip relay 2 (NO)		
X2-12:	Trip relay 2 (NO)		
X2-13:			
X2-14:			
X2-15:	Trip relay 1 (NO)		
X2-16:	Trip relay 1 (NO)		

## 7.6 VAM 4CSE interfaces



VAM4c conn

Table 14 - VAM 4CSE interfaces

Connector			
X1-1, 3:	Current input IL1		
X1-5, 7:	Current input IL2 / Io		
X1-9, 11:	Current input IL3		
X2-1:	+24V supply from master unit or external power supply		= COM1, COM2
X2-2:	GND		
X2-3:	CAN-L	Zone information (L>, I>)	
X2-4:	CAN-H		
X2-5:	Serial B	master slave com	
X2-6:	Serial A		
X2-7:	DI GND	L>	
X2-8:	DI (24-48Vdc)		
X2-9:	DO GND	TRIP	
X2-10:	DO +24Vdc		
X2-11:			
X2-12:			
X2-13:			
X2-14:			
X2-15:	Trip relay (NO)		
X2-16:	Trip relay (NO)		

## 7.7 VAM 4CRL interfaces

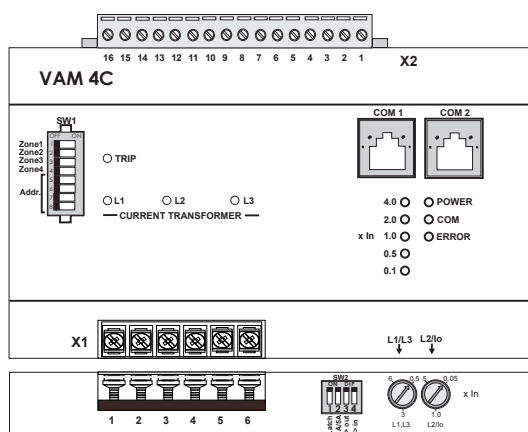

Table 15 - VAM 4CRL interfaces

Connector			
X1-1, 2:	Current input IL1		
X1-3, 4:	Current input IL2 / Io		
X1-5, 6:	Current input IL3		
X2-1:	+24V supply from master unit or external power supply		= COM1, COM2
X2-2:	GND		
X2-3:	CAN-L	Zone information (L>, I>)	
X2-4:	CAN-H		
X2-5:	Serial B	master slave com	
X2-6:	Serial A		
X2-7:	DI GND	L>	
X2-8:	DI (24-48Vdc)		
X2-9:	DO GND	TRIP	
X2-10:	DO +24Vdc		
X2-11:			
X2-12:			
X2-13:			
X2-14:			

Connector			
X2-15:	Trip relay (NO)		
X2-16:	Trip relay (NO)		

## 7.8 VAM 4CDSE interfaces

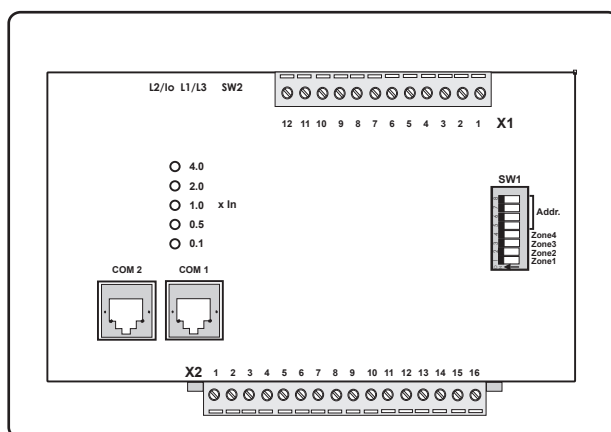

Table 16 - VAM 4CDSE interfaces

Connector			
X1-1, 3:	Current input IL1		
X1-5, 7:	Current input IL2 / Io		
X1-9, 11:	Current input IL3		
X2-1:	+24V supply from master unit or external power supply		= COM1, COM2
X2-2:	GND		
X2-3:	CAN-L	Zone information (L>, I>)	
X2-4:	CAN-H		
X2-5:	Serial B	master slave com	
X2-6:	Serial A		
X2-7:	DI GND	L>	
X2-8:	DI (24-48Vdc)		
X2-9:	DO GND	TRIP	
X2-10:	DO +24Vdc		

Connector			
X2-11:			
X2-12:			
X2-13:			
X2-14:			
X2-15:	Trip relay (NO)		
X2-16:	Trip relay (NO)		

## 7.9 VAMP 4RSE interfaces

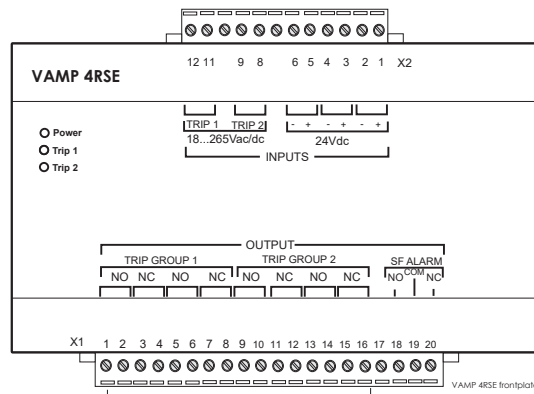

Table 17 - VAMP 4RSE interfaces

Connector			
X1-1, 2:	Trip relay (NO), Trip group 1.		
X1-3, 4:	Trip relay (NC), Trip group 1.		
X1-5, 6:	Trip relay (NO), Trip group 1.		
X1-7, 8:	Trip relay (NC), Trip group 1.		
X1-9, 10:	Trip relay (NO), Trip group 2.		
X1-11, 12:	Trip relay (NC), Trip group 2.		
X1-13, 14:	Trip relay (NO), Trip group 2.		

Connector			
X1-15, 16:	Trip relay (NC), Trip group 2.		
X1-17:			
X1-18:	NO	SF Alarm relay	
X1-19:	COM		
X1-20:	NC		
X2-1:	Aux voltage supply +24 Vdc		
X2-2:	GND		
X2-3:	Aux voltage supply +24 Vdc		
X2-4:	GND		
X2-5:	Aux voltage supply +24 Vdc		
X2-6:	GND		
X2-7:			
X2-8:	TRIP 2. Input 18–265 Vac/dc	Trip group 2.	
X2-9:	TRIP 2. Input 18–265 Vac/dc		
X2-10:			
X2-11:	TRIP 1. Input 18–265 Vac/dc	Trip group 1.	
X2-12:	TRIP 1. Input 18–265 Vac/dc		

## 8 I/O Technical data

### 8.1 Connections

Table 18 - VAM 3LSE

Sensor connections	3 fibre loop sensors (type ARC-SLx) 1 portable arc sensor (type VA 1 DP)
--------------------	---

Table 19 - VAM 3LXSE

Sensor connections	3 fibre loop sensors (type ARC-SLx) - sensitivity adjust range compared to 3L 0.5 (max) – 1.5 (min) 1 portable arc sensor (type VA 1 DP)
--------------------	---

Table 20 - VAM 10LSE, VAM 10LDSE, VAM 12LSE, VAM 12LDSE

Sensor connections	10 arc sensors (type VA 1 DA or VA 1 EH) 1 portable arc sensor (type VA 1 DP)
Terminal: - MSTB2.5 - 5.08	Cross-section area of wire Maximum 2.5 mm <sup>2</sup> (13–14 AWG) Minimum 1.5 mm <sup>2</sup> (15–16 AWG)

Table 21 - VAM 4CSE, VAM 4CDSE, VAM 4CRL

<b>Rated current L1 / L3</b>	1 or 5 A (optional) 50/60Hz
Current measuring zone	0–6 A (0–6*I <sub>N</sub> [I <sub>N</sub> = 1 A]); 0–30 A (0–6* I <sub>N</sub> [I <sub>N</sub> = 5 A])
Thermal withstand capability	300 A (for 1 s) 100 A (for 10 s) 20 A (continuous)
Power consumption	<0.3 VA
<b>Rated current L2 / I<sub>0</sub></b>	1 or 5 A (optional) 50/60Hz
Current measuring zone	0–6 A (0–6*I <sub>N</sub> [I <sub>N</sub> = 1 A]); 0–30 A (0–6*I <sub>N</sub> [I <sub>N</sub> = 5 A])
Thermal withstand capability	300 A (for 1 s) 100 A (for 10 s) 20 A (continuous)

Power consumption	<0.3 VA
Terminal: - single or multi-strand wire	Cross-section area of wire Maximum 4 mm <sup>2</sup> (11–12 AWG) Minimum 2.5 mm <sup>2</sup> (13–14 AWG)

## 8.2 Auxiliary power supply

Table 22 - VAM 10LSE, VAM 10LDSE, VAM 12LSE, VAM 12LDSE, VAM 4CSE, VAM 4CDSE, VAM 4CRL, VAM 3LSE, VAM 3LXSE

Rated voltage $U_{AUX}$	24 V dc (supplied by master unit or Class 2 power supply)
Power consumption	< 1 W (in normal mode) < 1.5 W (output relays activated)
Terminal: - MSTB2.5 - 5.08 (RJ 45 when supply from central unit)	- Cross-section area of wire Maximum 2.5 mm <sup>2</sup> (14 AWG) Minimum 1.5 mm <sup>2</sup> (16 AWG)

Table 23 - VAMP 4RSE

Rated voltage $U_{AUX}$	24 V dc (supplied by master unit or Class 2 power supply)
Current consumption - one relay group activated - both relay groups activated	20 mA stby 80 mA 180 mA

Table 24 - VA 1 DA, VA 1 EH, VA 1 DP

Rated voltage $U_{AUX}$	12 V dc (from I/O unit)
Power consumption	< 35 mW (in normal mode) < 450 mW (activated)

## 8.3 Digital inputs

**NOTE:** No digital inputs are available in VAM 12LSE and VAM 12LDSE.

Table 25 - VAM 10LSE, VAM 10LDSE, VAM 3LSE, VAM 3LXSE

Number of inputs	1 pcs I> in 1 arc fault trip out
Internal operating voltage	24–48 V dc (BIO in) 24 V dc (BIO out)
Load capacity (max.)	5 mA
Terminal: - MSTB2.5–5.08	Cross-section area of wire Maximum 2.5 mm <sup>2</sup> (14 AWG) Minimum 1.5 mm <sup>2</sup> (16 AWG)
Connection cable	Twisted pair with shield. Shield shall be grounded.

Table 26 - VAM 4CSE, VAM 4CDSE, VAM 4CRL

Number of inputs	1 pcs L> in 1 pcs I> out
Internal operating voltage	24–48 V dc (BIO in) 24 V dc (BIO out)
Load capacity (max.)	5 mA
Terminal: - MSTB2.5–5.08	Cross-section area of wire Maximum 2.5 mm <sup>2</sup> (14 AWG) Minimum 1.5 mm <sup>2</sup> (16 AWG)
Connection cable	Twisted pair with shield. Shield shall be grounded.

Table 27 - VAMP 4RSE

Operating voltage	18–265 V ac/dc
Current consumption	2 mA

## 8.4 Trip contacts

Table 28 - VAM 10LSE, VAM 10LDSE, VAM 12LSE, VAM 12LDSE, VAM 4CSE, VAM 4CDSE, VAM 4CRL, VAM 3LSE, VAM 3LXSE

Number of contacts for VAM 10LSE, VAM 10LDSE, VAM 4CSE, VAM 4CDSE, VAM 4CRL, VAM 3LSE, VAM 3LXSE	1 closing contact (relay T1)
Number of contacts for VAM 12LSE, VAM 12LDSE	3 closing contacts (relay T1)
Rated voltage	250 V ac/dc
Continuous withstand capacity	5 A
Make and carry for 0.5s	30 A
Make and carry for 3s	15 A
Breaking capacity, dc(L/R=40 ms)	
At 48 V dc:	1 A
At 110 V dc:	0.44 A
At 220 V dc:	0.22 A
Relay material	AgNi 90/10
Terminal: - MSTB2.5–5.08	Cross-section area of wire Maximum 2.5 mm <sup>2</sup> (14 AWG) Minimum 1.5 mm <sup>2</sup> (16 AWG)
Operate time (typical)	8 ms (+-20%)

Table 29 - VAMP 4RSE

4N/O / 4N/C rated voltage	250 V ac/dc
Operation time (typical)	< 10 ms
Continuous withstand capacity	5 A
Make and carry for 0.5s	30 A
Make and carry for 3s	15 A
N/O breaking capacity dc (L/R=40ms)	
At 48 V dc	1 A
At 110 V dc	0.44 A

At 220 V dc	0.22 A
Contact material	AgNi 90/10
Terminal: - MSTB2.5–5.08	Cross-section area of wire Maximum 2.5 mm <sup>2</sup> (14 AWG) Minimum 1.5 mm <sup>2</sup> (16 AWG)

## 8.5 Environmental conditions

Table 30 - Environmental conditions

Operating temperature range	-10 – 55°C (14 – 131°F)
Transport and storage temperature range	
- VAM I/O units	-40 – 70°C (-40 – 158°F)
- ARC SLm, VA 1 xx sensors	-40 – 85°C (-40 – 185°F)
Relative air humidity	< 95% (condensation not allowed)
Maximum operating altitude	2000 m (6561.68 ft)

## 8.6 Package

Table 31 - Package

Dimensions (WxHxD)	-
VAMP 4RSE, VAM I/O units	157 x 92 x 25 mm / 6.18 x 3.62 x 0.98 in
Weight (unit, box and user instructions)	-
VAMP 4RSE, VAM I/O units	0.62 kg (1.369 lb)

## 8.7 Disturbance tests

Table 32 - Disturbance tests

Test	Standard & Test class / level	Test value
<b>Emission</b>	EN 61000-6-4 / IEC 60255-26	
- Conducted	EN 55011, Class A / IEC 60255-25	0.01–30 MHz
- Emitted	EN 55011, Class A / IEC 60255-25	30–1000 MHz

Test	Standard & Test class / level	Test value
<b>Immunity</b>	EN 61000-6-2 / IEC 60255-26	
- 1 Mhz damped oscillatory wave	IEC 60255-22-1	±2.5 kVp CM, ±1.0 kVp DM
- Static discharge (ESD)	EN 61000-4-2 Level 4 / IEC 60255-22-2 Class 4	8 kV contact, 15 kV air
- Emitted HF field	EN 61000-4-3 Level 3 / IEC 60255-22-3	80–2700 MHz, 10 V/m
- Fast transients (EFT)	EN 61000-4-4 Level 4 / IEC 60255-22-4 Class A	4 kV, 5/50 ns, 5 kHz
- Surge	EN 61000-4-5 Level 3 / IEC 60255-22-5	2 kV, 1.2/50 µs, CM 1 kV, 1.2/50 µs, DM
- Conducted HF field	EN 61000-4-6 Level 3 / IEC 60255-22-6	0.15–80 MHz, 10 Vemf
- Power-frequency magnetic field	EN 61000-4-8	300 A/m (continuous), 1000 A/m 1–3 s
- Pulse magnetic field	EN 61000-4-9 Level 5	1000 A/m, 1.2/50 µs

## 8.8 Electrical safety tests

Table 33 - Electrical safety tests

Test	Standard & Test class / level	Test value
- Impulse voltage withstand	EN 60255-5, Class III	5 kV, 1.2/50 µs, 0.5 J
- Dielectric test	EN 60255-5, Class III	2 kV, 50 Hz
- Insulation resistance	EN 60255-5	
- Protective bonding resistance	EN 60255-27	

## 8.9 Environmental tests

Table 34 - Environmental tests

Test	Standard & Test class / level	Test value
<b>Device in operation</b>		
- Dry heat	EN / IEC 60068-2-2, Bd	65°C (149°F)
- Cold	EN / IEC 60068-2-1, Ad	-25°C (-13°F)
- Damp heat, cyclic	EN / IEC 60068-2-30, Db	<ul style="list-style-type: none"> <li>From 25°C (77°F) to 55°C (131°F)</li> <li>From 93% RH to 98% RH</li> <li>Testing duration: 6 days</li> </ul>
- Damp heat, static	EN / IEC 60068-2-78, Cab	<ul style="list-style-type: none"> <li>40°C (104°F)</li> <li>93% RH</li> <li>Testing duration: 10 days</li> </ul>
<b>Device in storage</b>		
- Dry heat	EN / IEC 60068-2-2, Bb	70°C (158°F)
- Cold	EN / IEC 60068-2-1, Ab	-40°C (-40°F)

## 8.10 Casing

Table 35 - VAM 10LSE, VAM 4CSE, VAM 4CRL, VAMP 4RSE, VAM 3LSE, VAM 3LXSE

Housing class (IEC 60529)	IP20
Housing class (NEMA)	NEMA 1
Housing class (UL 508)	Open type
Dimensions (W x H x D)	157 x 92 x 25 mm / 6.18 x 3.62 x 0.98 in
Material	1 mm (0.039 in) steel plate
Weight	0.52 kg (1.148 lb)
Colour code	RAL 7032 (housing) / RAL 70035 (back plate)

Table 36 - VAM 10LDSE, VAM 12LDSE, VAM 4CDSE

Housing class (IEC 60529)	IP54
Housing class (NEMA)	Front: NEMA 2 Rear: NEMA 1
Housing class (UL 508)	Front: Open type Rear: Open type
Dimensions (W x H x D)	185 x 120 x 25 mm / 7.28 x 4.72 x 0.98 in
Material	1 mm (0.039 in) steel plate
Weight	0.60 kg (1.325 lb)
Colour code	RAL 7032 (housing) / RAL 70035 (back plate)

Table 37 - VA 1 DA, VA 1 EH, VA 1 DP

Housing class (IEC 60529)	IP21
Housing class (NEMA)	NEMA 1
Housing class (UL 508)	Open type
Dimensions (W x H x D)	25 x 55 x 14 mm (VA 1 DA) Φ11 x 62 mm (VA 1 EH) Φ40 x 7 mm (VA 1 DP)
Material	Plastic
Weight	0.01 kg
Cable length	VA 1 DA and VA 1 EH: 6 m or 20 m VA 1 DP: 5 m

# 9 Construction

## 9.1 Dimensional drawings

### 9.1.1 VAM 3LSE / 3LXSE DIN rail mounting

VAM 3LSE/3LXSE DIN RAIL MOUNTING

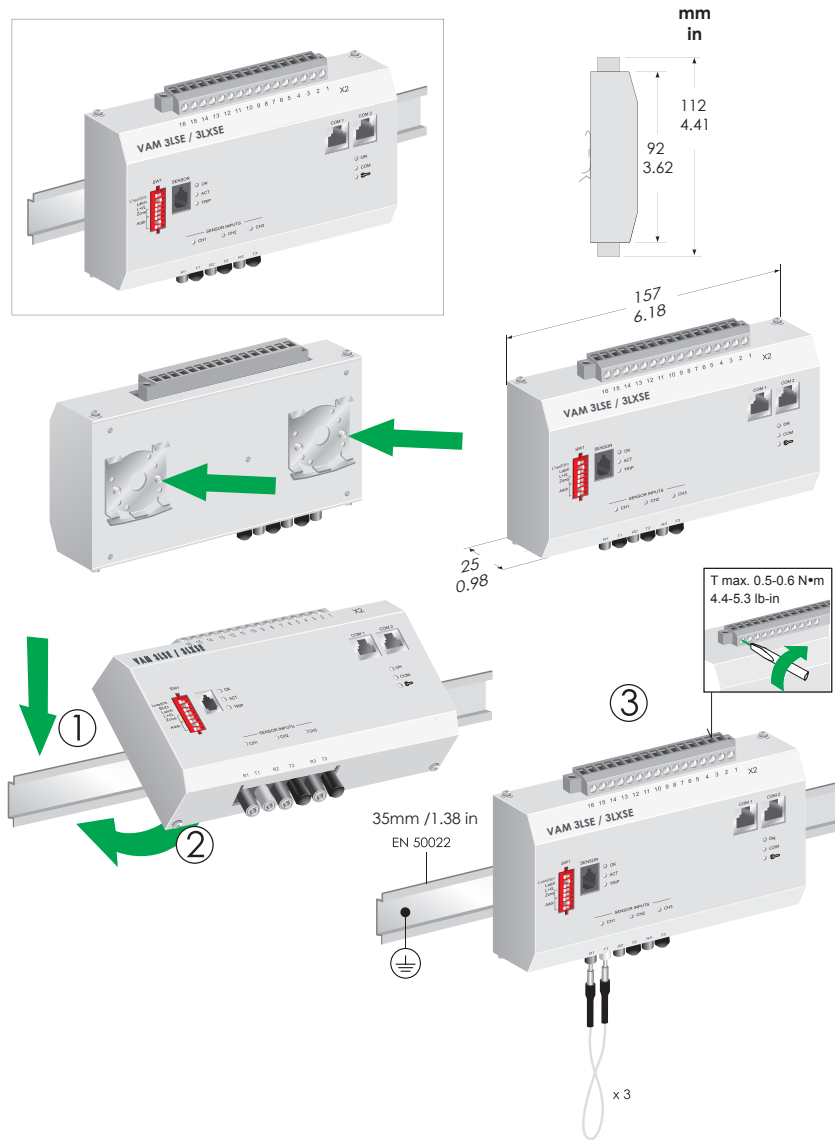

## 9.1.2 VAM 10LSE DIN rail mounting

### VAM 10L DIN RAIL MOUNTING

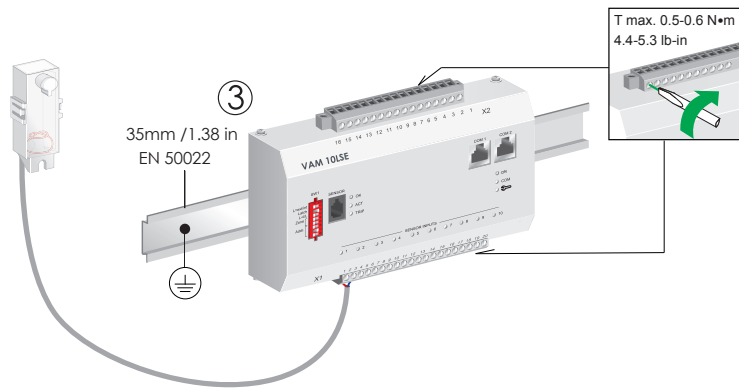
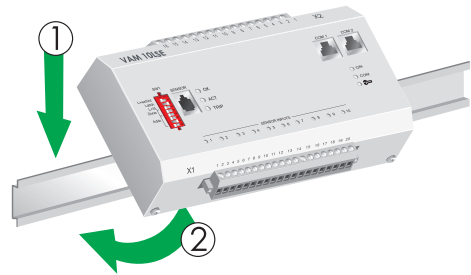
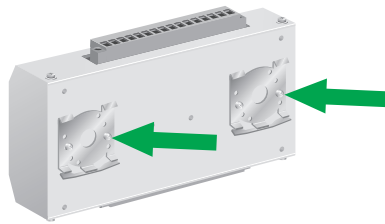
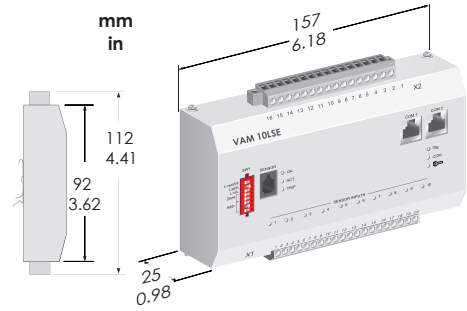
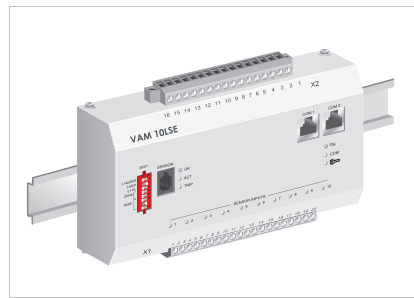

### 9.1.3 VAM 10LDSE Flush mounting

#### VAM 10LDSE FLUSH MOUNTING

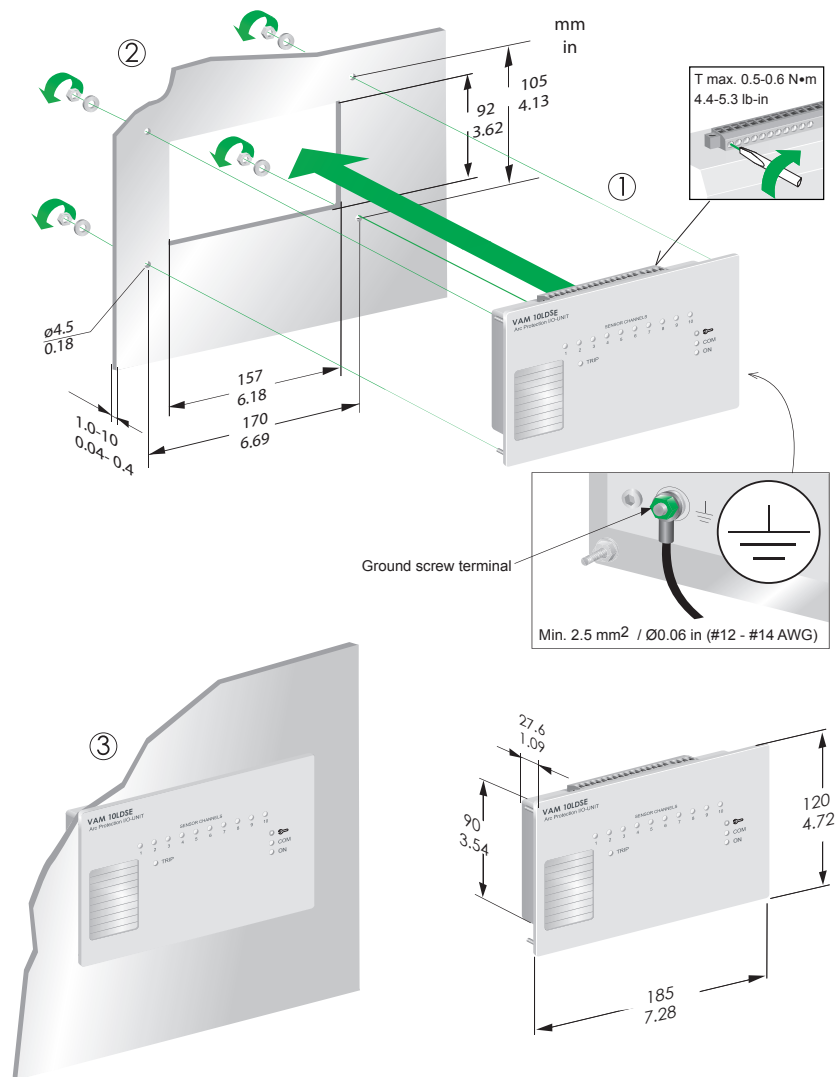

## 9.1.4 VAM 12LSE DIN rail mounting

### VAM 12LSE DIN RAIL MOUNTING

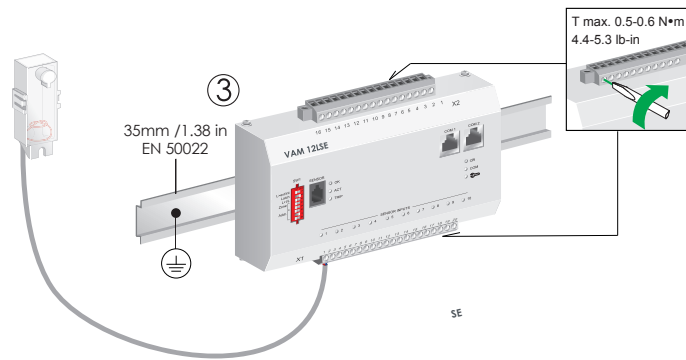
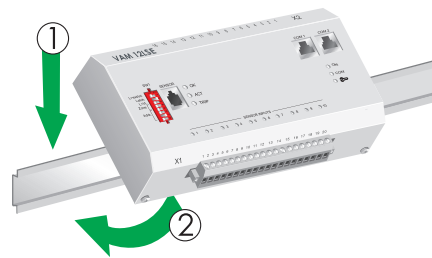
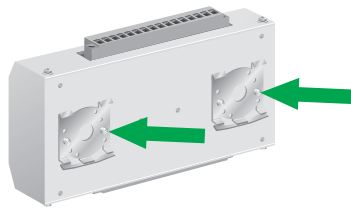
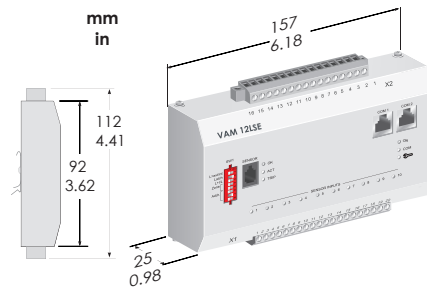
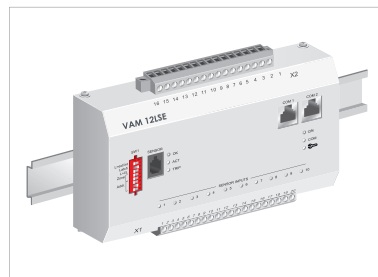

### 9.1.5 VAM 12LDSE Flush mounting

VAM 12LD FLUSH MOUNTING

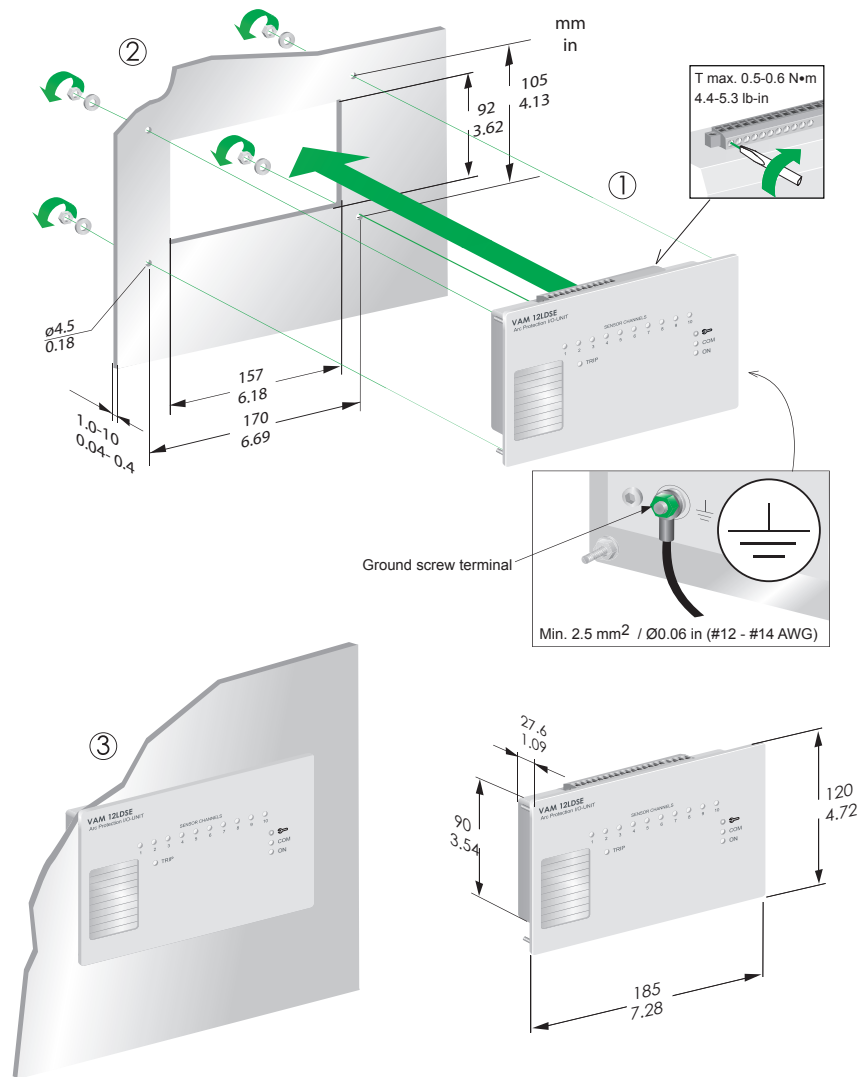

### 9.1.6 VAM 4CSE / 4CRL DIN rail mounting

The example is given with VAM 4CSE.

VAM 4C DIN RAIL MOUNTING

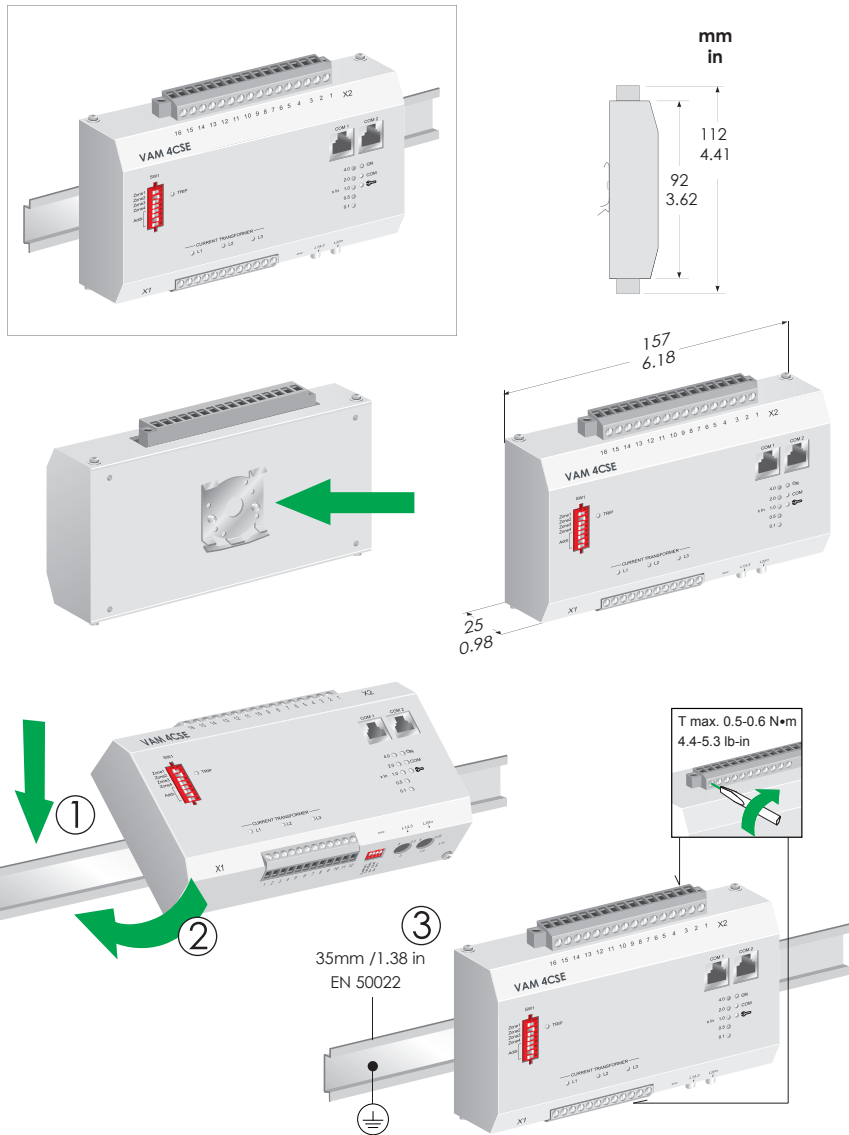

### 9.1.7 VAM 4CDSE Flush mounting

#### VAM 4CDSE FLUSH MOUNTING

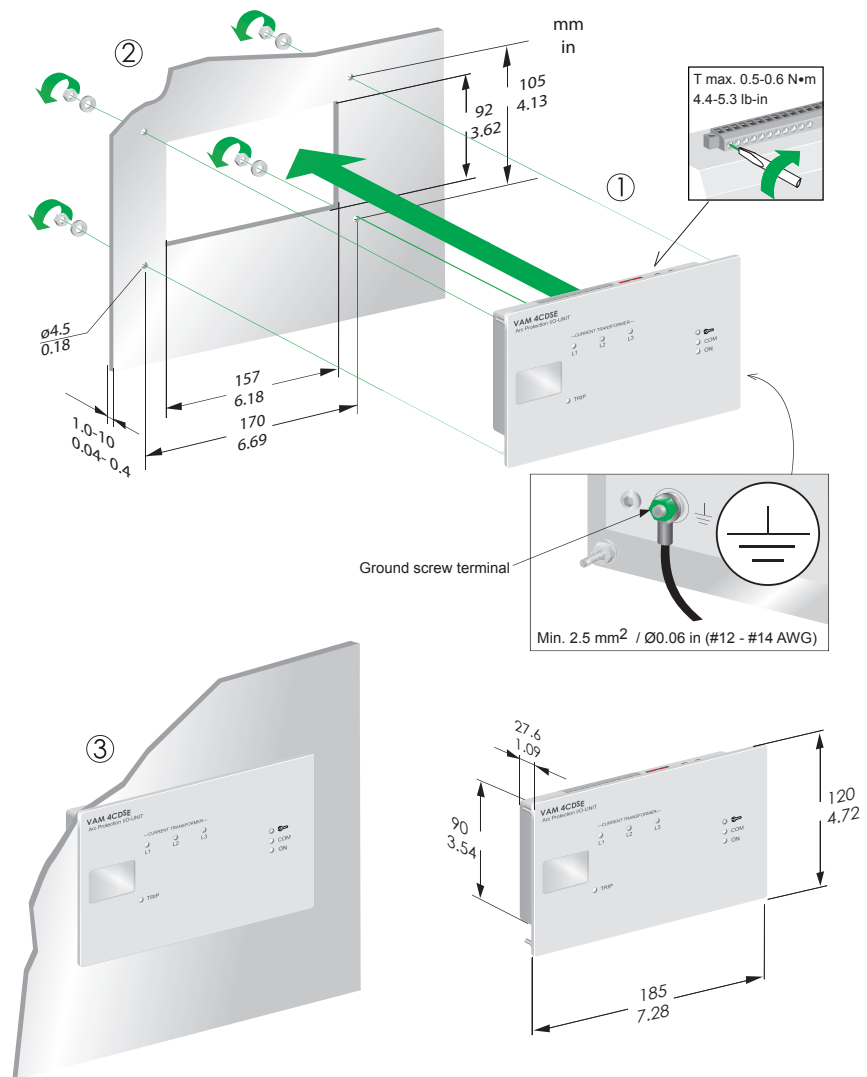

## 9.1.8 VAMP 4RSE DIN rail mounting

### VAMP 4RSE DIN RAIL MOUNTING

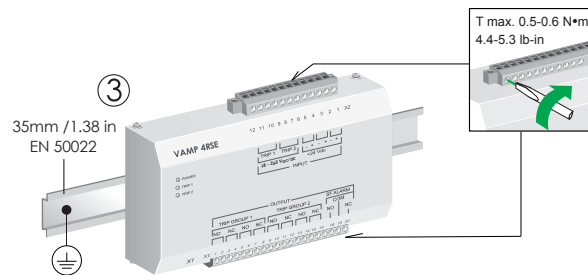
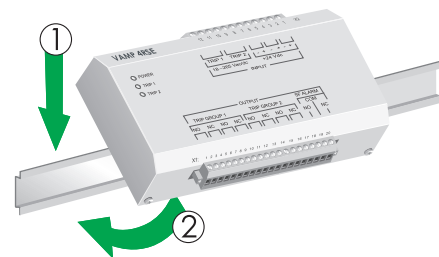
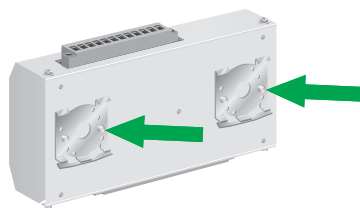
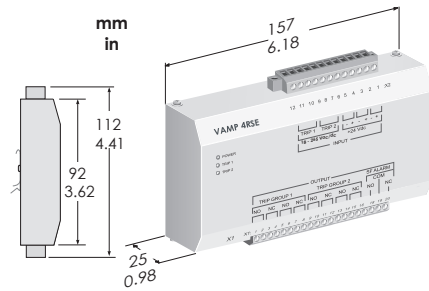
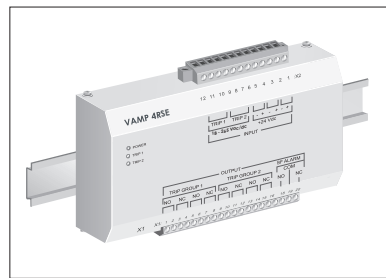

### 9.1.9 VA 1 DA

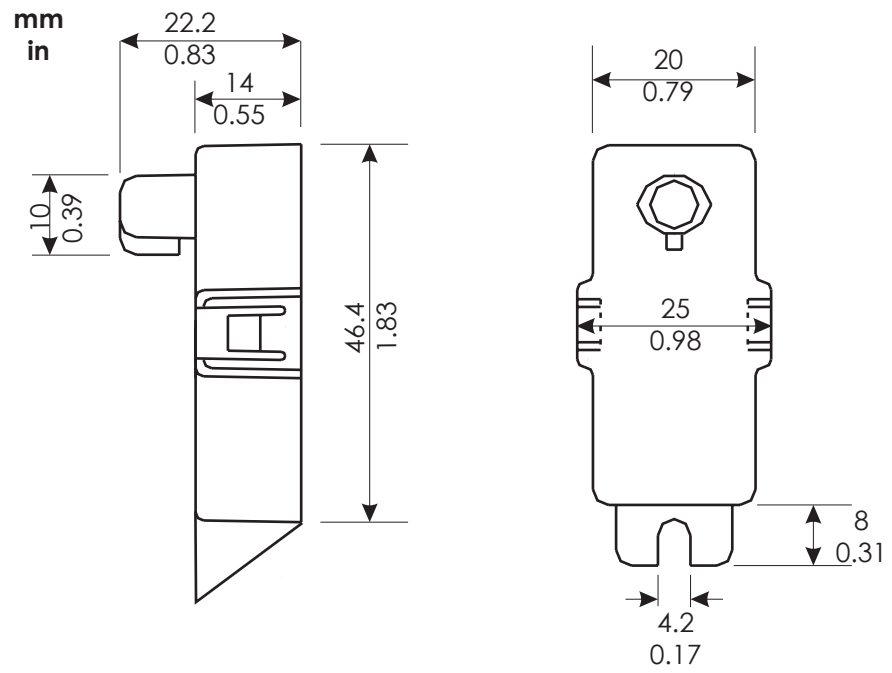

### 9.1.10 VA 1 EH

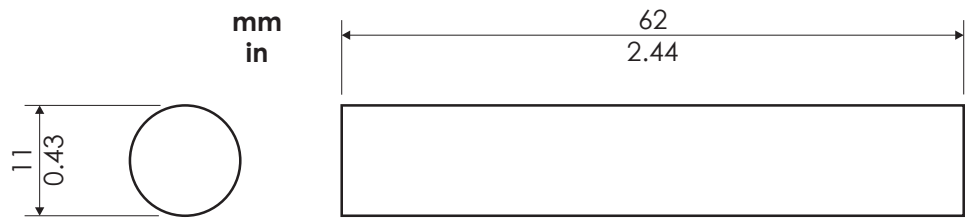

VA1EH\_mittakuva

### 9.1.11 VYX 001

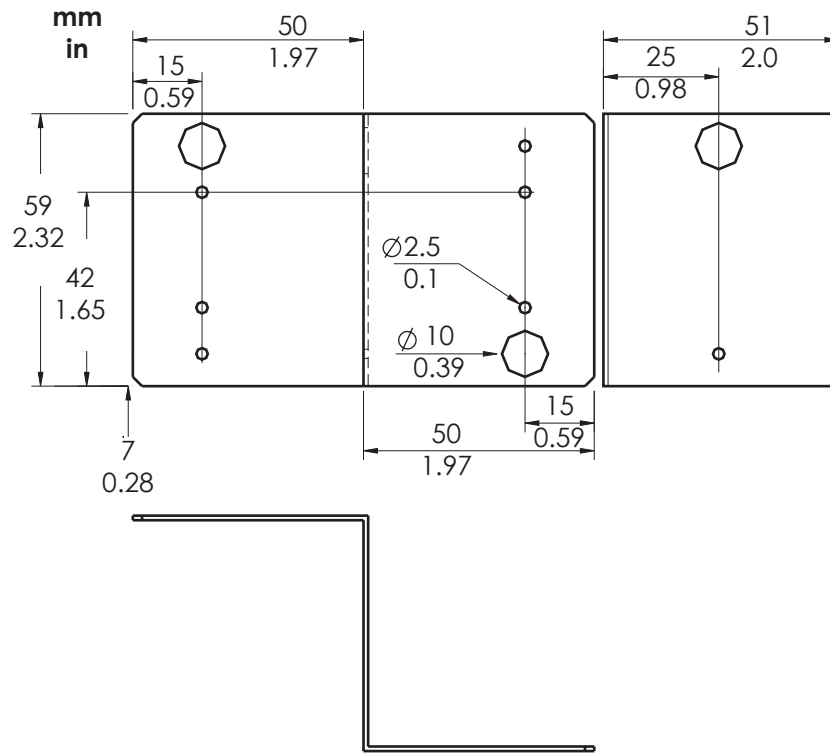

### 9.1.12 VYX 002

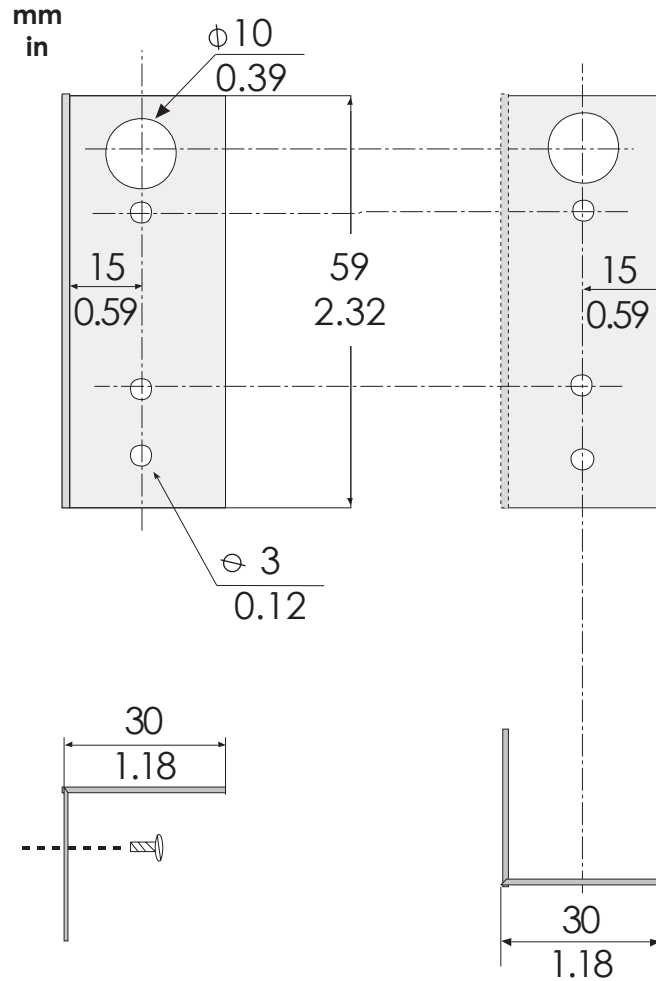

## 9.2 I/O unit mounting and wiring

### DANGER

#### HAZARD OF ELECTRIC SHOCK, EXPLOSION, OR ARC FLASH

- Apply appropriate personal protective equipment (PPE) and follow safe electrical work practices. See NFPA 70E, NOM-029-STPS-2011, or CSA Z462.
- The arc fault detection system is not a substitute for proper PPE when working on or near equipment being monitored by the system.
- Information on this product is offered as a tool for conducting arc flash hazard analysis. It is intended for use only by qualified persons who are knowledgeable about power system studies, power distribution equipment, and equipment installation practices. It is not intended as a substitute for the engineering judgement and adequate review necessary for such activities.
- Only qualified personnel should install and service this equipment. Read this entire set of instructions and check the technical characteristics of the device before performing such work.
- Perform wiring according to national standards (NEC) and any requirements specified by the customer.
- Observe any separately marked notes and warnings.
- NEVER work alone.
- Before performing visual inspections, tests, or maintenance on this equipment, disconnect all sources of electric power. Assume all circuits are live until they are completely de-energized, tested, and tagged. Pay particular attention to the design of the power system. Consider all sources of power, including the possibility of backfeeding.
- Always use a properly rated voltage sensing relay to ensure that all power is off.
- The equipment must be grounded.
- Connect the device's protective ground to functional earth according to the connection diagrams presented in this document.
- Do not open the device. It contains no user-serviceable parts.
- Install all devices, doors and covers before turning on the power to this device.

**Failure to follow these instructions will result in death or serious injury.**

#### Safety instructions

Always observe the national electrical safety regulations when working under live conditions. The unit manufacturer is not liable for damage due to incorrect working methods or failure to observe safety instructions.

The correct handling of the unit under all mounting and operating conditions forms the foundation for its safe use.

**⚡⚠ DANGER****HAZARD OF ELECTRIC SHOCK, EXPLOSION, OR ARC FLASH**

Observe any separately marked notes and warnings.

The wiring work must be performed according to national standards and any requirements specified by the customer.

Do not connect the auxiliary supply voltage until the installation has been completed.

**Failure to follow this instruction will result in death or serious injury.**

**Before installation**

Before installation, make sure the environmental conditions comply with the requirements specified in the *Connections* chapter of this document.

**NOTE:** The unit contains components liable to damage if exposed to an electrostatic discharge (ESD). Do not open the unit unless you have taken appropriate protective measures against ESD.

**⚠ WARNING****HAZARD OF UNEXPECTED OPERATION**

The manufacturer cannot guarantee operational safety in environments that do not satisfy the specified environmental conditions.

**Failure to follow these instructions can result in death, serious injury, or equipment damage.**

**Related topics**

[Connections](#) on page 29

**9.2.1 VAM 10LSE, VAM 12LSE, VAM 4CSE, VAM 4CRL, VAM 3LSE, VAM 3LXSE**

The units are designed for mounting on a DIN rail. Mount the units on the rail in such a way that the indicator lights on the front panel are visible and the sensor wiring can be made as easily as possible.

**9.2.2 VAM 10LDSE, VAM 12LDSE, VAM 4CDSE**

The units are designed for mounting on a door. Hence all indicators are clearly visible in normal operation.

**9.3 Connecting the VAMP 321 I/O units**

The I/O units can be connected to the components listed below:

- Enclosure current transformer secondary circuits (VAM 4CSE, VAM 4CDSE and VAM 4CRL I/O units only)
- Circuit breaker trip circuits
- External auxiliary supply circuits
- Connections to the VAMP 321 central unit or other I/O units (data communication and auxiliary supply)
- Connections to other central units or detection relays (digital input (DI) or digital output (DO) bus)

## 9.4 Connecting the secondary circuits of the current transformers (VAM 4CSE / VAM 4CDSE / VAM 4CRL only)

Connect the secondary circuits of the current transformers to the following screw connectors:

- X1-1, X1-3 ( $L_1$ )
- X1-5, X1-7 ( $L_2/I_0$ )
- X1-9, X1-11 ( $L_3$ )

The arc protection system can also be single or two-phase connected. Three-phase connection is nevertheless recommended for optimal operating speed.

### DANGER

#### HAZARD OF ELECTRICAL SHOCK

Do not open the secondary circuit of a live current transformer.

Disconnecting the secondary circuit of a live current transformer may cause dangerous overvoltages.

**Failure to follow these instructions will result in death or serious injury.**

**NOTE:** The current measuring channels  $L_1$  and  $L_3$  must be used in connection with two-phase current measuring. Single-phase current or ground fault current must always be connected to the current measuring channel  $L_2/I_0$ ; otherwise, an unbalance error will occur.

The specified operating time can only be guaranteed for three-phase current measurement and with the proper voltage supply to all system components, minimum allowed auxiliary voltage is 21.6 Vdc.

The VAM 4CSE / VAM 4CDSE / VAM 4CRL overcurrent unbalance alarm settings recognizes if the two-phase or three-phase monitoring is being used based on the connections made to the unit and the overcurrent limits set for each connection. The two-phase connection monitoring is triggered when the  $L_2/I_0$  connection overcurrent limit differs from the  $L_1/L_3$  overcurrent limit settings by 90% or more. This is because in the event two-phase monitoring is used, the  $L_2/I_0$  connection is the connection used to monitor the ground current.

Therefore, the current limit set for the  $L_2/I_0$  connection should reflect limits associated with anticipated ground currents. The remaining  $L_1/L_3$  currents should be balanced, and overcurrent settings for the  $L_1/L_3$  connection should be reflected as such. The two-phase monitoring mode is also referred to as “ground-fault mode.”

The three-phase monitoring is triggered when the  $L_2/I_0$  and  $L_1/L_3$  overcurrent limit settings are similar, reflecting that each phase is understood to be in balance with the other two phases.

If detected, the system gives an unbalance alarm after a 10-second delay time. The alarm does not affect other operations of the arc detection system.

The phase discontinuity settings are non-adjustable since all the setting values have been programmed in the current-monitoring unit.

## 9.5 Connecting the trip circuits of the circuit breakers

Connect the circuit breaker's trip circuit to the following pins:

**TRIP1: X2-15, X2-16**

For example, in the event of an arc fault, the output contact will close at specified time when three-phase current measurement is used.

The output trip relay of the light I/O units (VAM 10LSE and VAM 3LSE) operates during faults in its own zone. In the current I/O unit (VAM 4CSE), select the protection zone controlling the I/O unit using the programming switches.

If several trips are required, the multiplying relay VAMP 4RSE can be used. If VAMP 4RSE is used, make sure that proper voltage supply is connected to device.

## 9.6 Connecting the central unit to the I/O unit

Connect the central unit to the I/O units with a modular cable of type VX001. The modular cable carries all information between the central unit and I/O units, including data in serial form, arc fault messages and operating supply to the I/O units.

### **⚠ CAUTION**

#### **HAZARD OF EQUIPMENT DAMAGE**

Do not connect modular cables in a closed loop.

**Failure to follow these instructions can result in personal injury or equipment damage.**

### **NOTICE**

#### **HAZARD OF EQUIPMENT DAMAGE**

Only VAMP communication cable type VX001 shall be used.

Modular cable wiring shall be placed on the control cabling trays as far from the primary cable, bus bar and bus ducts as possible.

Do not connect Ethernet to ARC I/O Bus!

**Failure to follow these instructions can result in equipment damage.**

1. Connect the VX001 cable to the arc I/O COM interface of the central units.

2. Connect the cable to COM1 or COM2 on the first I/O unit.
3. Route the cable from COM1 or COM2 on the first I/O unit to COM1 or COM2 in the next unit, etc.

All the COM1 and COM2 interfaces are identical, i.e. the cable can always be connected to either interface. The maximum total length of the modular cable, taking into account all the I/O units connected to the central unit, is 100 m.

**NOTE:** Use only star connection for I/O units. Maximum single bus cable length is 30 meters.

## 9.7 Connecting separate auxiliary supplies

When routing modular cables over long distances (30 meters of modular cabling) or when the system contains more than 4 I/O units you should preferably use a separate auxiliary +24Vdc voltage supply with output monitoring along with the modular bus cabling.

Recommended types of power supplies with output monitoring:

- Easergy PS25 EMS58586 (48W @ 24Vdc)
- With optional battery:
  - EMS58584: 12V, 2.5Ah, 5 years life span
  - EMS58589: 12V, 5.5Ah, 12 years life span
- or any equivalent type of power supply with the above functionality

**NOTE:** Use of power supplies without voltage monitoring is not recommended.

Connect the auxiliary supply to the 24 V terminals of the last I/O unit. Use at least 1.5mm<sup>2</sup> (AWG 16) size twisted pair cable.

**NOTE:** It is recommended to use external wiring to connect auxiliary supply to all units. Pay particular attention to the polarity of the wire and cable connections.

Table 38 - Connecting separate auxiliary supplies





	Additional power supply cabling is recommended, min. 1.5 mm <sup>2</sup> (AWG 16)
	
	Power supply cabling, min. 1.5 mm <sup>2</sup> (AWG 16)
	
	Modular Arc I/O bus cable

Figure 14 - External power supply wiring

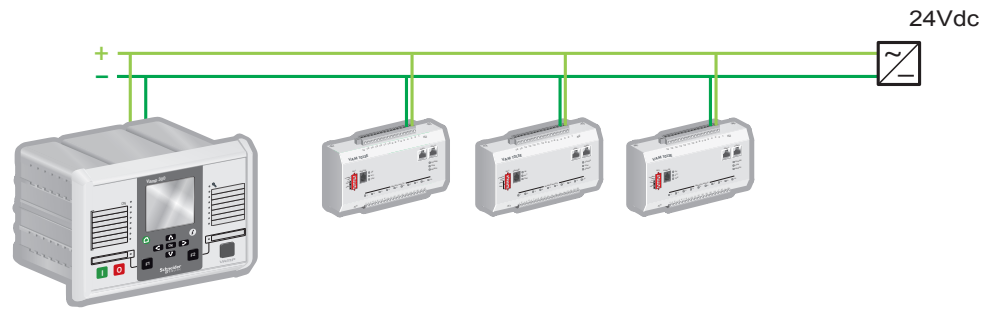
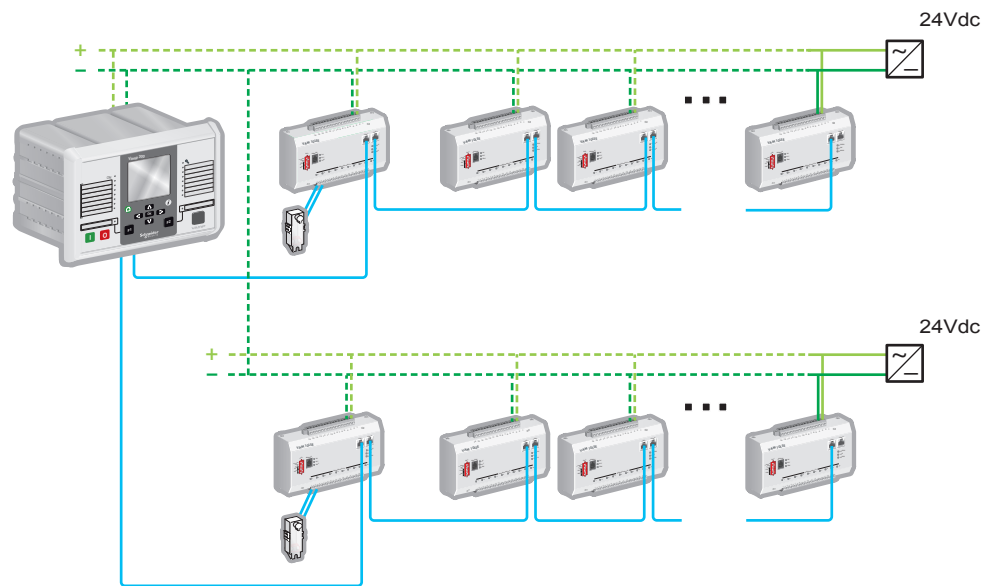
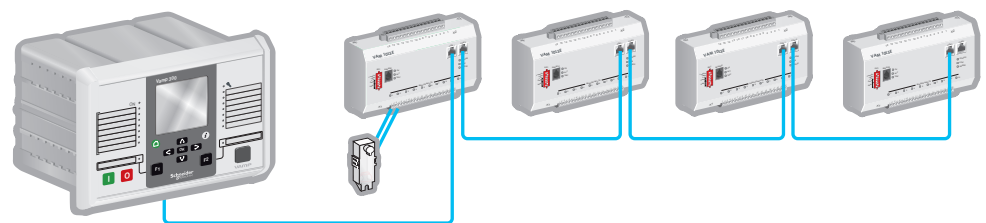

Figure 15 - Protection system wiring configuration



Two branch design, length of cabling must not exceed 100 m combine total in both branches.

Figure 16 - Small protection system wiring configuration, one branch design



If four or less I/O units are used, total cable length is below 30 m. No power supply is needed.

Figure 17 - Protection system wiring configuration, one branch design

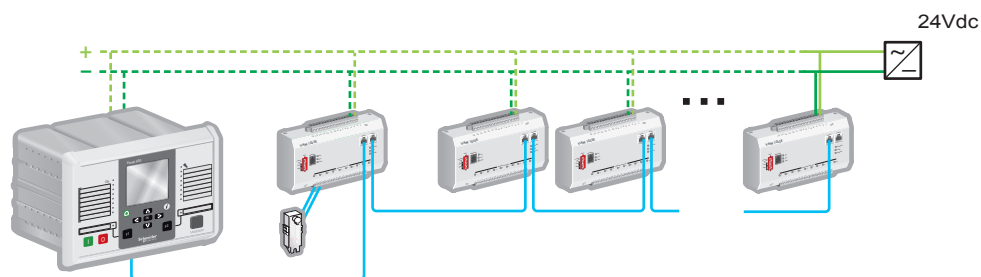

Systems having more than four I/O units must be equipped with separate auxiliary supply.

## 9.8 Connecting VAMP 4RSE

The multiplying relay VAMP 4RSE can be used when additional trip outputs are needed.

VAMP 4RSE comprises 4 N/O contacts and 4 N/C contacts. They are divided into two separate groups which can be independently controlled by e.g. the binary output of the I/O units or the central unit.

Figure 18 - VAMP 4RSE block diagram

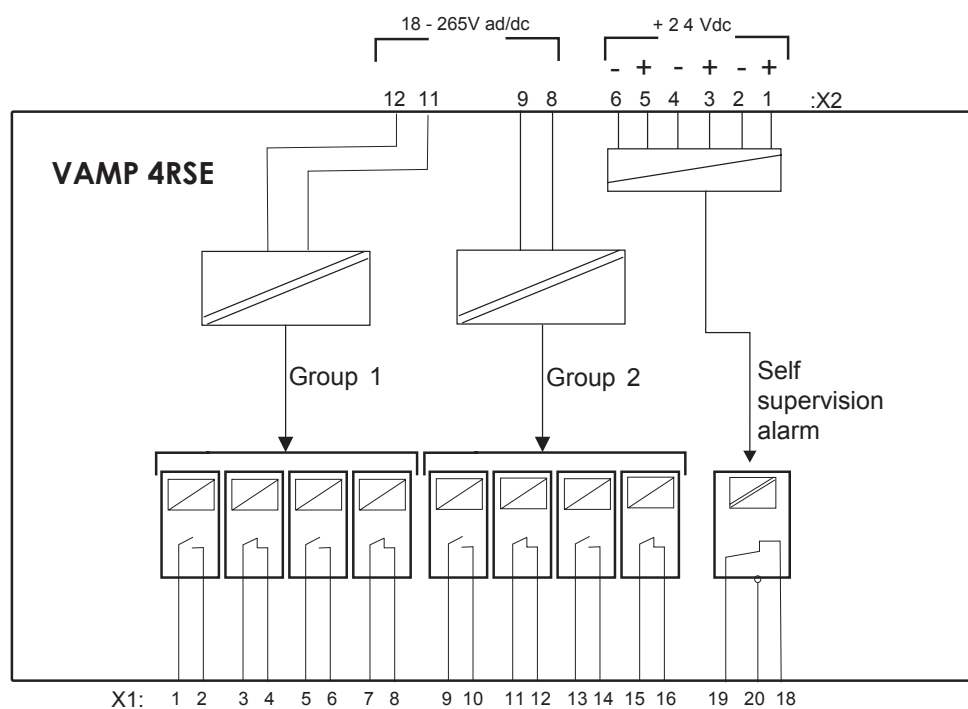

1. Attach the VAMP 4RSE unit to a DIN rail.
2. Connect the auxiliary voltage ( +24V ) to terminal X2-1 (+) and X2-2 (-).

Terminals X2-3 and X2-5 are parallel inputs to X2-1(+). Terminals X2-4 and X2-6 are parallel inputs to X2-2(1). The auxiliary voltage ( +24V ) can be supplied from the central unit or nearest slave ( X2-1 (+), X2-2 (-)).

3. Connect the required signal (18-265 V ad/dc) to the trip control inputs.

Input "TRIP 1" ( X2-11, X2-12 ) is controlling the trip group 1.

Input "TRIP 2" ( X2-8, X2-9 ) is controlling the trip group 2.

There are 2xN/C + 2xN/O contacts per trip group.

If necessary, input TRIP 1 and 2 can be connected in parallel. Then all trip relays will operate simultaneously.

## 9.9 Wiring multiple central units

A maximum of 16 I/O units and/or central units in 'slave' mode can be connected to one communication bus. In this case, the units can operate on a maximum of four protection zones (depending on their programming switches). The light and current signals given by the I/O units, including address information, are transferred to each central unit.

If more than one central unit is to be connected to the same communication bus, one central unit must be in central unit mode and the other central units in sub-unit mode.

In applications with multiple central units the central units can be interconnected also via BI/O connections (binary input/output). In this case, each part of the system can control four protection zones per system communication bus. In this case, arc and overcurrent information is transferred between the central units without address information.

**NOTE:** When configuring Vamp 221 arc protection system with multiple central units, disconnect I/O-units from central units in slave mode during their installation procedure.

## 9.10 Arc sensors

Mount the sensors on the switchgear in such a way that they cover the protection zone as completely as possible. The line of sight must be free between the sensor and the supervised area.

If point sensors are used in open compartments (such as bus-bar sections), there should be a sensor approximately every 5 meters. Due to the wide detection range of the sensors and the light reflection inside the switchgear, the mounting position is not critical.

### Connecting sensors VA 1 DA and VA 1 EH to the I/O units

The sensors are delivered with 6-metre standard cables or 20-metre shielded cables (to be specified in the order).

After mounting the sensors, connect them to the I/O units as follows:

- Draw the wire to the nearest I/O unit using the shortest route possible and cut it to a suitable length.
- Connect the arc sensors to the screw terminals X1-1...20. The polarity of the arc sensor cables is not critical.

### Connecting the ARC-SLx sensors to the I/O units

The sensors are delivered in standard lengths (to be specified in the order) equipped with terminals compatible with VAM 3L units.

After mounting the sensors, connect them to the I/O units as follows:

- Draw each end of the sensor to the I/O unit and carefully form a loop of the extra fibre.
- Connect the arc sensors to plug-in terminals X1-R1, T1...R3, T3. While the polarity of the arc sensors is not critical, you must connect each end of the fibre to the same channels.

**NOTE:** Check that the sensor positioning has not changed during shipping and commissioning.

Use a separate VAMP Arc Flash Protection Testing Manual for testing testing each sensor during commissioning.

### 9.10.1 VA 1 DA arc flash sensor

**⚠ DANGER**

**HAZARD OF NON-DETECTED LIGHT**

Clean the arc sensor periodically as instructed in this user manual and after an arc flash fault.

**Failure to follow these instructions will result in death or serious injury.**

VA 1 DA is a point-type arc flash sensor. The sensor activated by strong light. It transforms the light information into the current signal that is used by the device to detect arc flash light.

Figure 19 - Sensor dimensions

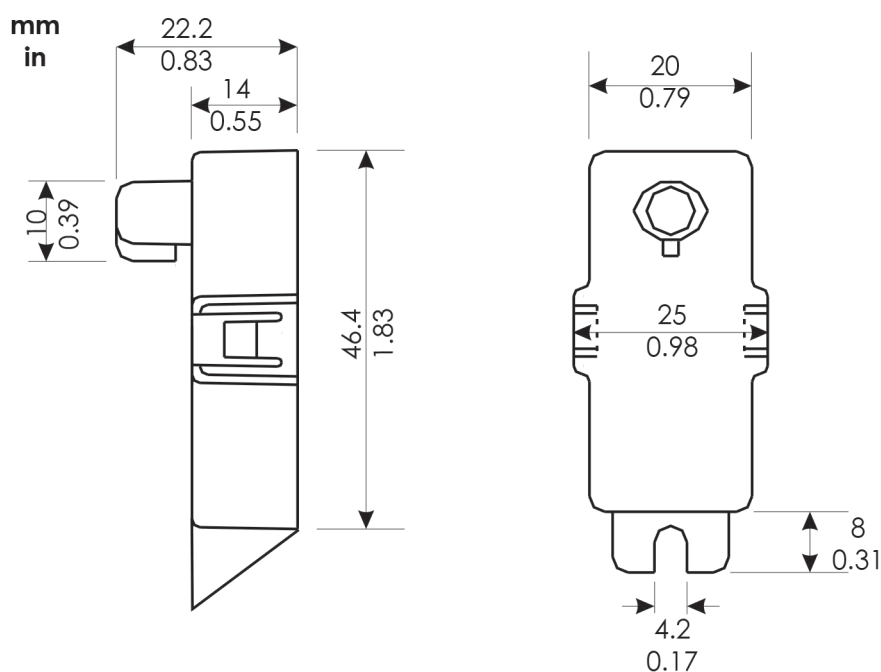

The sensor features include:

- standard 8000–10000 lux visible light sensitivity
- wide area arc flash detection
- maximum 2 ms detection time
- standard cable length 6 m (236.22 in) or 20 m (787.40 in) (cut to length on site)
- easy to install (two-wired non-polarity sensitive connection)

**⚠ DANGER**

**HAZARD OF NON-DETECTED LIGHT**

Never attempt to extend the length of arc flash sensor cables.

**Failure to follow these instructions will result in death or serious injury.**

### 9.10.1.1 Mounting the sensors to the switchgear

## DANGER

### HAZARD OF ELECTRIC SHOCK, EXPLOSION, OR ARC FLASH

- Apply appropriate personal protective equipment (PPE) and follow safe electrical work practices. See NFPA 70E, NOM-029-STPS-2011, or CSA Z462.
- The arc fault detection system is not a substitute for proper PPE when working on or near equipment being monitored by the system.
- Information on this product is offered as a tool for conducting arc flash hazard analysis. It is intended for use only by qualified persons who are knowledgeable about power system studies, power distribution equipment, and equipment installation practices. It is not intended as a substitute for the engineering judgement and adequate review necessary for such activities.
- Only qualified personnel should install and service this equipment. Read this entire set of instructions and check the technical characteristics of the device before performing such work.
- Perform wiring according to national standards (NEC) and any requirements specified by the customer.
- Observe any separately marked notes and warnings.
- NEVER work alone.
- Before performing visual inspections, tests, or maintenance on this equipment, disconnect all sources of electric power. Assume all circuits are live until they are completely de-energized, tested, and tagged. Pay particular attention to the design of the power system. Consider all sources of power, including the possibility of backfeeding.
- Always use a properly rated voltage sensing relay to ensure that all power is off.
- The equipment must be grounded.
- Connect the device's protective ground to functional earth according to the connection diagrams presented in this document.
- Do not open the device. It contains no user-serviceable parts.
- Install all devices, doors and covers before turning on the power to this device.

**Failure to follow these instructions will result in death or serious injury.**

Install arc flash sensors inside the switchgear. There are two options for mounting the sensors:

- in customer-drilled holes on the switchgear
- on VYX001 Z-shape or VYX002 L-shape mounting plates available from Schneider Electric or locally fabricated from supplied drawings

Figure 20 - VYX 001 mounting plate for sensor

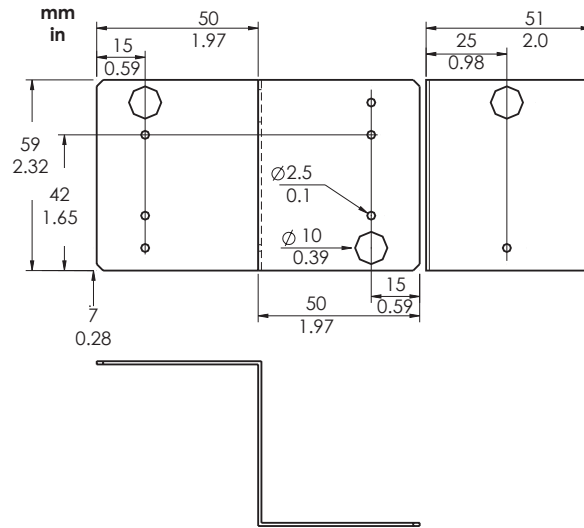

Figure 21 - VYX 002 mounting plate for sensor

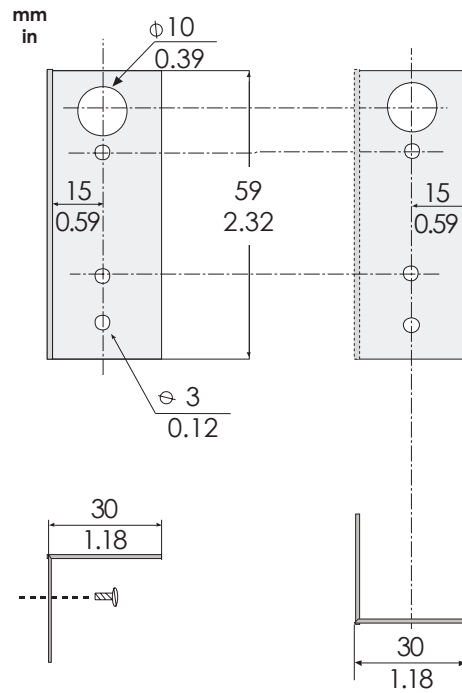
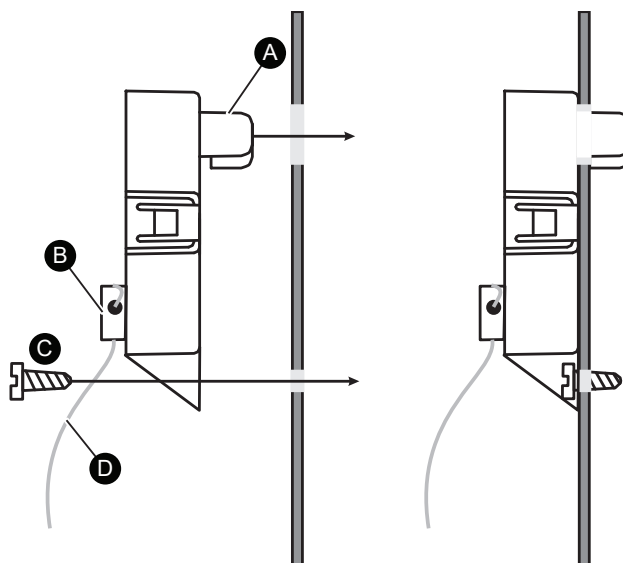

Figure 22 - Mounting the sensor



- A. Active part of the sensor
- B. Cable clamp
- C. Fastening screw 4 x 15 mm
- D. Sensor cable

1. Press the active part of the sensor through the 10 mm hole in the panel surface.
2. Fix it using a 4 mm screw.

### 9.10.1.2 Connecting the sensors to the device

The sensors are delivered with 6 or 20 m cables.

## ⚠ DANGER

### HAZARD OF NON-DETECTED LIGHT

Never attempt to extend the length of arc flash sensor cables.

**Failure to follow these instructions will result in death or serious injury.**

After mounting the sensors, connect them to the device.

1. Route the wire to the nearest device using the shortest route possible.  
Cut the wire to a suitable length.  
Take into account the wiring methods inside the equipment. This should be compliant with local regulations.
2. Connect the arc sensors to the screw terminals.  
The polarity of the arc sensor cables is not critical.

## 9.10.2 VA 1 EH

You can install the arc sensor onto the switchgear wall from the outside. Press the active part of the sensor through the 10.5-mm hole in the wall.

You can also surface mount the sensor. To do this, push the sensor into a plastic mounting tube and fix it with heat shrink tubing.

**NOTE:** The sensor must not be exposed to direct sunlight or other strong light. Do not mount the sensor directly under a light source.

Figure 23 - Arc sensor VA 1 EH



## 9.10.3 ARC-SLx

ARC-SLx is a fibre sensor that can be mounted on the switchgear to monitor several compartments simultaneously (various bus-bar compartments, etc.).

The fibre must not touch any live parts of the switchgear or other hot components, since too high temperatures may destroy the fibre.

When mounting the sensor on the switchgear, ensure that the bending radius is long enough (min. 50 mm) and that it is safe from the sharp edges of the switchgear.

**NOTE:** The sensor must not be exposed to direct sunlight or other strong light. Do not mount the sensor directly under a light source.

**NOTE:** To avoid false tripping, cover any unused channels of the I/O unit.

Figure 24 - ARC-SLx



#### 9.10.4 VA 1 DP

The portable pin sensor can be temporarily connected to the I/O units. It is used to improve safety when working with live switchgear, for example. Attach the sensor close to the working area, for example in the breast pocket of the maintenance man.

A pin sensor operates in the same way as a fixed arc sensor. The only difference is free mobility within the limits of the connecting cable.

Figure 25 - Pin sensor VA 1 DP



**NOTE:** To avoid faulty tripping, disconnect the pin sensor from the system immediately after use.

**⚠ DANGER**

**HAZARD OF ELECTRIC SHOCK, ELECTRIC ARC OR BURNS**

Ensure that trip signal will control main breaker in case of Arc flash incident!

**Failure to follow these instructions will result in death or serious injury.**

## 10 Order information

Order code	Description	Note
VAM 3LSE	Fibre sensor I/O unit (VAMP 221 and 321)	3 fibre loops, 1 trip relay
VAM 3LXSE	Fibre sensor I/O unit (VAMP 221 and 321)	3 fibre loops, 1 trip relay, adjustable sensitivity
VAM 4CSE	Current I/O unit (VAMP 221 and 321)	3 current inputs, 1 trip relay
VAM 4CDSE	Current I/O unit (VAMP 221 and 321)	3 current inputs, 1 trip relay, flush mounting
VAM 4CRL	Current I/O unit (VAMP 221 and 321)	3 current inputs, 1 trip relay, ring-lug connector
VAM 10LSE	Point sensor I/O unit (VAMP 221 and 321)	10 sensor inputs, 1 trip relay
VAM 10LDSE	Point sensor I/O unit (VAMP 221 and 321)	10 sensor inputs, 1 trip relay, flush mounting
VAM 12LSE	Point sensor I/O unit (VAMP 221 and 321)	10 sensor inputs, 3 trip relays
VAM 12LDSE	Point sensor I/O unit (VAMP 221 and 321)	10 sensor inputs, 3 trip relays, flush mounting
VAMP 4RSE	Trip multiplier relay	4 x NO, 4 x NC, 2 groups
VA 1 DA-6	Arc sensor	Cable length 6 m (19.69 ft)
VA 1 DA-20	Arc sensor	Cable length 20 m (65.62 ft)
VA 1 DA-6s	Arc Sensor, shielded	Cable length 6 m (19.69 ft)
VA 1 DA-20s	Arc Sensor, shielded	Cable length 20 m (65.62 ft)
VA 1 DA-6-HF	Arc Sensor, halogen free	Cable length 6 m (19.69 ft)
VA 1 DA-20-HF	Arc Sensor, halogen free	Cable length 20 m (65.62 ft)
VA 1 EH-6	Arc Sensor (Pipe type)	Cable length 6 m (19.69 ft)
VA 1 EH-20	Arc Sensor (Pipe type)	Cable length 20 m (65.62 ft)
VA 1 EH-6S-IP	Arc Sensor, shielded (Pipe type, IP65)	Cable length 6 m (19.69 ft)
VA 1 EH-20S-IP	Arc Sensor, shielded (Pipe type, IP65)	Cable length 20 m (65.62 ft)
VA 1 EH-20-IP	Arc Sensor (Pipe type, IP65)	Cable length 20 m (65.62 ft)
VA 1 DP-5	Portable Arc Sensor	Cable length 5 m (16.41 ft)
VA 1 DP-5D	Portable Arc Sensor	Cable length 5 m (16.41 ft)
VA 1 GIS-1,5	Arc Sensor, shielded with GIS adapter	Cable length 1.5 m (4.93 ft)

Order code	Description	Note
VA 1 GIS-3	Arc Sensor, shielded with GIS adapter	Cable length 3 m (9.85 ft)
VA 1 GIS-5	Arc Sensor, shielded with GIS adapter	Cable length 5 m (16.41 ft)
VA 1 GIS-10	Arc Sensor, shielded with GIS adapter	Cable length 10 m (32.81 ft)
ARC SLM-x	Fibre sensor, 8 000 lx	x = fiber length <sup>3</sup>
VX001-xx	Modular Cable VAM - VAM ( xx = Cable length [m] )	Preferred Cable Lengths <sup>4</sup>
VX031-5	Extension cable for VA1DP-5D	Cable length 5 m (16.41 ft)
VX052-3	USB programming cable (VAMPSET)	Cable length 3 m (9.85 ft)
VX072	VAMP 300/321 profibus cable	Cable length 3 m (9.85 ft)
VYX 001	Surface Mounting Plate for Sensors	Z-shaped
VYX 002	Surface Mounting Plate for Sensors	L-shaped
VYX 628	Surface Mounting Plate for VA 1 DV Sensor	U-shaped
VYX 695	Projection for 300-series	Height 45 mm (1.78 in)
VSE001PP	Fibre optic Interface Module (plastic - plastic)	Max. distance 30 m (99 ft)
VSE002	RS485 Interface Module	
VPA 3CG	Profibus DP fieldbus option board	
3P001	Line amplifier for arc protection BI/O channels	DIN rail mount
3P004	Supply unit, 100-240AC/24DC/1.3A	Supply unit

<sup>3</sup> **Fibre lengths:** 1, 5, 10, 15, 20, 25, 30, 35, 40, 50, 60 or 70 m

<sup>4</sup> **Cable lengths:** 1, 3, 5, 7, 10, 15, 20, 25 & 30 m



## Schneider Electric

35 rue Joseph Monier  
92500 Rueil Malmaison - France  
Phone: +33 (0) 1 41 29 70 00  
[www.schneider-electric.com](http://www.schneider-electric.com)

As standards, specifications, and designs change from time to time,  
please ask for confirmation of the information given in this publication.

© 2020 Schneider Electric All Rights Reserved.

VIO/en M/C006 — 03/2020