

# PowerLogic power-monitoring units

## EM3500 Series DIN Rail Meter

Technical data sheet



# EM3500

## Functions and characteristics

PB105431



PowerLogic™ EM3500

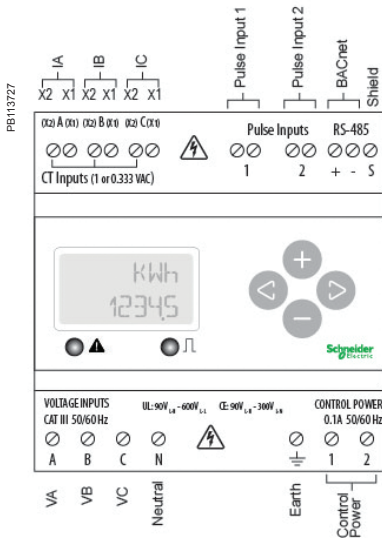

EM3500 parts and connection terminals

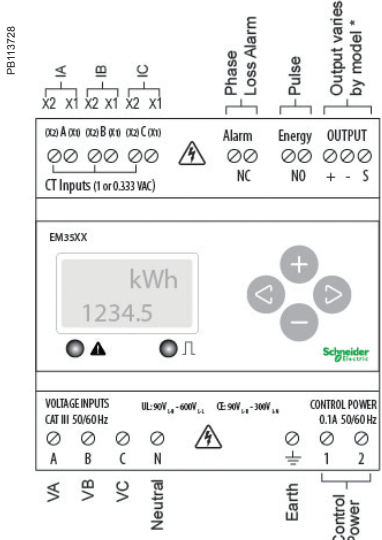

EM3502/EM355x parts and connection terminals

### Description

The EM3500 Series DIN Rail Meter combines exceptional performance and easy installation to deliver a cost-effective solution for power monitoring applications. The EM35xx can be installed on standard DIN rail or surface mounted as needed. Pulse output and phase alarms provide additional versatility. The Modbus and BACnet output options offer added flexibility for system integration. The data logging capability (EM3555 and EM3560) protects data in the event of a power failure. Modbus, pulse output, and phase alarms are all provided to suit a wide variety of applications.

Additional pulse inputs on EM3560 provide an easy way to incorporate simple flow sensors to track gas, water, steam, or other energy forms using a BACnet system in addition to full monitoring of electrical energy.

EM35xxA (Pulse, Modbus, BACnet) models designed for use exclusively with U018 Rope CTs where integrator and power supply for the CTs are built into the meter. Fewer devices to purchase and faster to install. (Not recommended for high harmonic applications.)

The EM3555 models adds a bi-directional monitoring feature designed expressly for renewable energy applications, allowing measurement of power imported from the utility grid as well as power exported from the renewable energy source (e.g. solar panels). In this way, a facility administrator track all energy data, ensuring accuracy in billing and crediting.

### Applications

- Energy monitoring in building automation systems
- Renewable energy monitoring
- Energy management
- Commercial submetering
- Industrial monitoring
- Cost allocation

### Features

#### All Models: A compact solution for panelboard monitoring

- DIN rail mounting option; easy installation
- ANSI 12.20 0.5% accuracy, IEC 62053-22 Class 0.5S; great for cost allocation
- Real energy output and phase loss alarm output on EM3502(A), EM3550(A), and EM3555 models; one device serves multiple applications
- 90-600 VAC; application versatility with fewer models to stock
- Bright backlit LCD; easy visibility in dark enclosures
- Data logging capability EM3555 and EM3560(A); safeguard during power failures
- EM35xx models compatible with LVCTs from 5A to 32000A; wide range of service types
- User-enabled password protection; prevents tampering
- EM35xxA models are designed to work exclusively with U018 Rope Style CTs 20-5000A range. Eliminate site walks, save time and money. (Not recommended in high harmonic applications.)
- System integration via Modbus EM355xx(A) or BACnet MS/TP EM356xx(A); convenient compatibility with existing systems
- Native BACnet MS/TP support (no gateway) with serial rates up to 115.2 kbaud EM3560, EM3561, EM3560A, & EM3561A

#### EM3555 Models: An essential solution for Solar and other renewable energy applications

- Bi-directional metering (4-quadrant); allows net metering
- Data logging capability; ensures long term data retrieval
- CSI approved

Model	Description	Part Numbers
EM3502	Pulse out only	METSEEM3502
EM3550	Modbus - 2 quadrant	METSEEM3550
EM3555	Modbus - 4 quadrant with logging	METSEEM3555
EM3560	BACnet with logging	METSEEM3560
EM3502A	Pulse Rope CT model	METSEEM3502A
EM3550A	Modbus Rope CT Model	METSEEM3550A
EM3560A	BACnet w/ logging Rope CT Model	METSEEM3560A
EM3561	BACnet without logging	METSEEM3561
EM3561A	BACnet without loggingRope CT Model	METSEEM3561A

# EM3500

## Functions and characteristics (cont.)

PB106437



EM3500 in enclosure with door open

PB113747

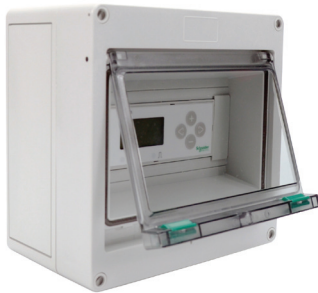

EM3500 in enclosure with door open

### Selection guide

#### Electrical characteristics

Inputs	Control Power, AC	50/60 Hz; 5VA max.; 90V min.; UL Maximums: 600V L-L (347V L-N); CE Maximums: 300V L-N (520V L-L)	
	Control Power, DC	3W max.; UL and CE: 125 to 300VDC (external DC current limiting required)	
	Voltage Input	UL: 90 V L-N to 600 V L-L ; CE: 90 V L-N to 300 V L	
	Current Input	Scaling	5 A to 32,000 A Non "A" models only 20A to 5000A for "A" models only
		Input Range	1/3V and 1V nominal LVCT (selectable) Non "A" models only U018 CTs only for "A" models
	Pulse Inputs (EM3560 & EM3560A)	Two sets of contact inputs to pulse accumulators	
Accuracy	Real Power and Energy	0.2% (ANSI C12.20, IEC 62053-22 Class 0.2S) EM3555 only	
Outputs	All Models (EM3560, EM3560A, EM3561 & EM3561A)	Real Energy Pulse: N.O. static; Alarm contacts: N.C. static	
	EM3502	Reactive energy pulse 30 VAC/DC	
	EM3550, EM3555, EM3550A	RS-485 2-wire Modbus RTU (1200 baud to 38.4 kbaud)	
	EM3560, EM3560A, EM3561, EM3561A	RS-485 2-wire BACnet MS/TP (9600 baud to 115.2 kbaud)	

#### Mechanical characteristics

Mounting	DIN Rail or 3-point screw mount
----------	---------------------------------

#### Environmental conditions

Operating temperature Range	-30° to 70°C (-22° to 158°F)
Storage Temperature Range	-40° to 85°C (-40° to 185°F)
Humidity Range	<95% RH noncondensing

#### Accessories

NEMA 4x enclosure (EM3500-ENC, pictured)
Split-core low voltage CTs (LVCTxx)
Fuse kits (EFP1, EFP2, EFP3)

#### Safety

US and Canada (cULus) UL508 (open type device)/CSA 22.2 No. 14-05
Europe (CE) EN61010-1:2001

# EM3500

## Functions and characteristics (cont.)

	EM3502	EM3550	EM3560	EM3561	EM3555	EM3502A	EM3550A	EM3560A	EM3561A
<b>Measurement Capability, Full Data Set</b>									
Bi-directional Energy Measurements					■				
Power (3-phase total and per phase): Real (kW) Reactive (kVAR), and Apparent (kVA)	■	■	■	■	■	■	■	■	■
Power Factor: 3-phase average & per phase	■	■	■	■	■	■	■	■	■
Present Power Demand: Real (kW), Reactive (kVAR), and Apparent (kVA)	■	■	■	■	■	■	■	■	■
Import and Export totals of Present Power Demand: Real (kW), Reactive (kVAR), & Apparent (kVA)					■				
Peak Power Demand: Real (kW), Reactive (kVAR), and Apparent (kVA)	■	■	■	■	■	■	■	■	■
Current (3-phase average and per phase)	■	■	■	■	■	■	■	■	■
Voltage: Line-Line and Line-Neutral (3-phase average and per phase)	■	■	■	■	■	■	■	■	■
Frequency	■	■	■	■	■	■	■	■	■
ANSI C12.20 0.5% accuracy, IEC 62053-22 Class 0.5S	■	■	■	■		■	■	■	■
ANSI C12.20 0.2% accuracy, IEC 62053-22 Class 0.2S					■				
Accumulated Net Energy: Real (kWh), Reactive (kVARh), and Apparent (kVAh)	■	■	■	■	■	■	■	■	■
Accumulated Real Energy by phase (kWh)	■	■	■	■	■	■	■	■	■
Import and Export Accumulators of Real and Apparent Energy					■				
Reactive Energy Accumulators by Quadrant (3-phase total & per phase)					■				
Demand Interval Configuration: Fixed or Rolling Block	■	■	■	■	■	■	■	■	■
Demand Interval Configuration: External Sync to Comms		■	■	■	■		■	■	■
<b>Data Logging (Store up to 60 days at 15-minute interval)</b>									
Data Logging: 10 16-Bit Configurable (can include Date/Time) Data Buffers					■				
Data Logging: 3 Timestamped 32-Bit Configurable Data Buffers				■					■
<b>Outputs</b>									
Alarm Output (N.C.)	■	■	■		■	■	■	■	■
1 Pulse Output (N.O.)		■			■		■		
2 Pulse Outputs (N.O.)	■					■			
RS-485 Serial (Modbus RTU Protocol)		■			■		■		
RS-485 Serial (BACnet MS/TP Protocol)			■	■				■	■
LON FT Serial (LonTalk Protocol)									
<b>Inputs</b>									
2 Pulse Contact Accumulator Inputs				■					■
1 Pulse Contact Accumulator Input			■					■	

FB 105436

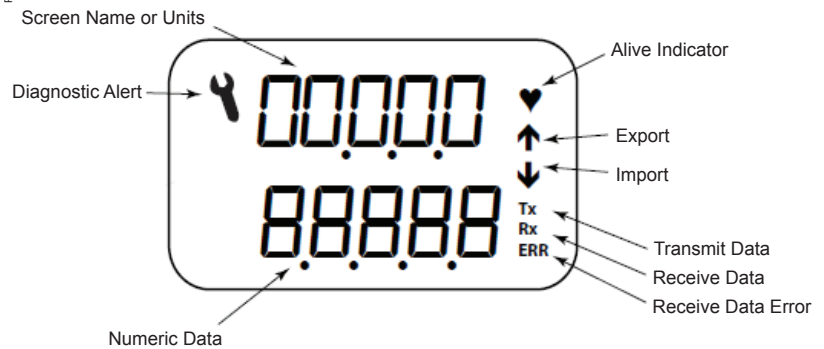

# EM3500

## Functions and characteristics (cont.)

### EM3500 dimensions

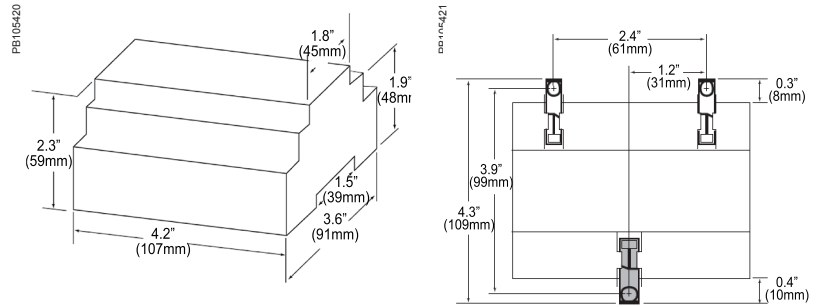

### EM3500 dimensions

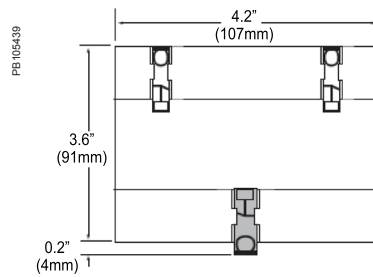

Bottom View (DIN Mount Option)

### EM3500 connections

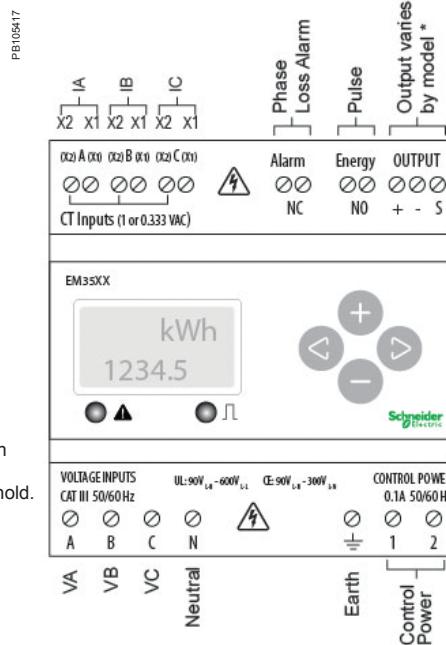

Two 5-character rows of display text.  
Top row alphanumeric;  
Bottom row numeric only

The red Alarm LED lights when any of the 3 phase voltages drop below the selected threshold.

The green Energy LED lights momentarily each time the Energy output pulse is active.

Please see EM3500 User Guide and EM3500 Install Guide for safe and correct wiring and connection information.

Schneider Electric Industries SAS  
35, Rue Joseph Monier,  
CS 30323  
F - 92506 Rueil Malmaison Cedex

RCS Nanterre 954 503 439  
Capital social 896 313 776  
[www.schneider-electric.com](http://www.schneider-electric.com)

PLSED310037EN

As standards, specifications and designs develop from time to time, please ask for confirmation of the information given in this document.

 *Printed on recycled paper*  
Design: Schneider Electric  
Photos: Schneider Electric  
Printing: Altavia Connexion - Made in France



April 2014