

EM3560

Compact Power and Energy Meter

Installation Guide

ZL0094-0A

11/2011



HAZARD CATEGORIES AND SPECIAL SYMBOLS

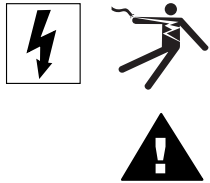

Read these instructions carefully and look at the equipment to become familiar with the device before trying to install, operate, service or maintain it. The following special messages may appear throughout this bulletin or on the equipment to warn of potential hazards or to call attention to information that clarifies or simplifies a procedure.

The addition of either symbol to a “Danger” or “Warning” safety label indicates that an electrical hazard exists which will result in personal injury if the instructions are not followed.

This is the safety alert symbol. It is used to alert you to potential personal injury hazards. Obey all safety messages that follow this symbol to avoid possible injury or death.

⚠ DANGER

DANGER indicates an imminently hazardous situation which, if not avoided, **will result in** death or serious injury.

⚠ WARNING

WARNING indicates a potentially hazardous situation which, if not avoided, **can result in** death or serious injury.

⚠ CAUTION

CAUTION indicates a potentially hazardous situation which, if not avoided, **can result in** minor or moderate injury.

CAUTION

CAUTION, used without the safety alert symbol, indicates a potentially hazardous situation which, if not avoided, **can result in** property damage.

NOTE: Provides additional information to clarify or simplify a procedure.

PLEASE NOTE

Electrical equipment should be installed, operated, serviced, and maintained only by qualified personnel. No responsibility is assumed by Schneider Electric for any consequences arising out of the use of this material.

FCC NOTICE

This equipment has been tested and found to comply with the limits for a Class B digital device, pursuant to part 15 of the FCC Rules. These limits are designed to provide reasonable protection against harmful interference when the equipment is operated in a residential environment. This equipment generates, uses, and can radiate radio frequency energy and, if not installed and used in accordance with the instruction manual, may cause harmful interference to radio communications. Operation of this equipment in a residential area is likely to cause harmful interference in which case the user will be required to correct the interference at his own expense.

This Class B digital apparatus complies with Canadian ICES-003.

CONTENTS

Safety Precautions.....	1
Installation Overview.....	1
Specifications.....	2
Introduction.....	4
Parts of the EM Series.....	4
Dimensions.....	5
Data Output.....	6
Installation.....	7
Supported System Types.....	8
Wiring.....	9
Wiring Diagrams.....	10
Control Power.....	11
Fuse Recommendations.....	11
Wiring Notes.....	11
Display Screen Diagram.....	12
Quick Setup Instructions.....	13
Pulse Contact Inputs.....	14
User Interface Menu Abbreviations Defined.....	15
User Interface for Data Configuration.....	16
Alert/Reset Information.....	17
User Interface for Setup.....	18
RS-485 Communications.....	20
BACnet Default Settings.....	21
BACnet Programming Information.....	22
BACnet PICS.....	23
Data Logging.....	31
Troubleshooting.....	33
China RoHS Compliance Information.....	33

SAFETY PRECAUTIONS

⚠ DANGER

HAZARD OF ELECTRIC SHOCK, EXPLOSION, OR ARC FLASH

- Follow safe electrical work practices. See NFPA 70E in the USA or applicable local codes.
- This equipment must only be installed and serviced by qualified electrical personnel.
- Read, understand, and follow the instructions before installing this product.
- Turn off all power supplying equipment before working on or inside the equipment.
- Always use a properly rated voltage sensing device to confirm power is off.
- **DO NOT DEPEND ON THIS PRODUCT FOR VOLTAGE INDICATION.**
- Only install this product on insulated conductors.
- Install device in an appropriate electrical and fire enclosure per local regulations.
- ESD sensitive equipment. Ground yourself and discharge any static charge before handling this device.
- Any covers that may be displaced during the installation must be reinstalled before powering the unit.
- Do not install on the load side of a Variable Frequency Drive (VFD), aka Variable Speed Drive (VSD) or Adjustable Frequency Drive (AFD).

Failure to follow these instructions will result in death or serious injury.

INSTALLATION OVERVIEW

A. DIN Rail Mounting

The meter can be mounted in two ways: on standard 35 mm DIN rail or screw-mounted to the interior surface of the enclosure.

1. Disconnect and lock out power. Use a properly rated voltage sensing device to confirm power is off.
2. Attach mounting clips to the underside of the housing by sliding them into the slots from the inside. The stopping pegs must face the housing, and the outside edge of the clip must be flush with the outside edge of the housing.
3. Snap the clips onto the DIN rail.
4. To prevent horizontal shifting across the DIN rail, use two end stop clips.

B. Screw Mounting

1. Disconnect and lock out power. Use a properly rated voltage sensing device to confirm power is off.
2. Attach the mounting clips to the underside of the housing by sliding them into the slots from the outside. The stopping pegs must face the housing, and the screw hole must be exposed on the outside of the housing.
3. Use three #8 screws (not supplied) to mount the meter to the inside of the enclosure.

NOTE: For detailed instructions, please see the "Installation" section later in this guide.

SPECIFICATIONS

Table 1 Specifications

Type	Description
Measurement Accuracy	
Real Power and Energy	IEC 62053-22 Class 0.5S, ANSI C12.20 0.5%
Reactive Power and Energy	IEC 62053-23 Class 2, 2%
Current	0.4% (+0.015% per °C deviation from 25°C) from 5% to 100% of range; 0.8% (+0.015% per °C deviation from 25°C) from 1% to 5% of range
Voltage	0.4% (+0.015% per °C deviation from 25°C) from 90 V L-N to 600 VAC L-L
Sample Rate	2520 samples per second, no blind time
Data Update Rate	1 sec
Type of Measurement	True RMS; One to three phase AC system
Input Voltage Characteristics	
Measured AC Voltage	Minimum 90 V _{L-N} (156 V _{L-L}) for stated accuracy; UL Maximums: 600 V _{L-L} (347 V _{L-N}); CE Maximums: 300 V _{L-N} (520 V _{L-L})
Metering Over-Range	+20%
Impedance	2.5 MΩ _{L-N} /5 MΩ _{L-L}
Frequency Range	45 to 65 Hz
Input Current Characteristics	
CT Scaling	Primary: Adjustable from 5 A to 32,000 A
Measurement Input Range	0 to 0.333 VAC or 0 to 1.0 VAC (+20% over-range)
Impedance	10.6 kΩ (1/3 V mode) or 32.1 kΩ (1 V mode)
Control Power	
AC	5 VA max.; 90 V min.; UL Maximums: 600 V _{L-L} (347 V _{L-N}); CE Maximums: 300 V _{L-N} (520 V _{L-L})
DC*	3 W max.; UL and CE: 125 to 300 VDC
Ride Through Time	100 msec at 120 VAC
Input	
Pulse	Solid-State or mechanical contacts (current less than 1 mA)
Minimum Pulse Width	20 msec
Output	
RS-485	2-wire, 9600 to 115.2 kbaud, BACnet MS/TP
Mechanical Characteristics	
Weight	0.62 lb (0.28 kg)
IP Degree of Protection (IEC 60529)	IP40 front display; IP20 Meter
Display Characteristics	Back-lit blue LCD
Terminal Block Screw Torque	3.5 in·lb (0.4 N·m) nominal/4.4 in·lb (0.5 N·m) max.
Terminal Block Wire Size	14 to 24 AWG
Rail	T35 (35mm) DIN Rail per EN50022

Type	Description
Environmental Conditions	
Operating Temperature	-30° to 70°C (-22° to 158°F)
Storage Temperature	-40° to 85°C (-40° to 185°F)
Humidity Range	<95% RH (non-condensing)
Altitude of Operation	3 km max.
Metering Category	
US and Canada	CAT III; for distribution systems up to 347 V _{L-N} /600 VAC _{L-L}
CE	CAT III; for distribution systems up to 300 V _{L-N} /480 VAC _{L-L}
Dielectric Withstand	Per UL 508, EN61010
Conducted and Radiated Emissions	FCC part 15 Class B, EN55011/EN61000 Class B; (residential and light industrial)
Conducted and Radiated Immunity	EN61000 Class A (heavy industrial)
Safety	
US and Canada (cULus)	UL508 (open type device)/CSA 22.2 No. 14-05
Europe (CE)	EN61010-1:2001

* External DC current limiting is required, see fuse recommendations.

For use in a Pollution Degree 2 or better environment only. A Pollution Degree 2 environment must control conductive pollution and the possibility of condensation or high humidity. Consideration must be given to the enclosure, the correct use of ventilation, thermal properties of the equipment and the relationship with the environment.

Always use this product in the manner specified or the protection provided by the product may be impaired.

Provide a disconnect device to disconnect the meter from the supply source. Place this device in close proximity to the equipment and within easy reach of the operator, and mark it as the disconnecting device. The disconnecting device shall meet the relevant requirements of IEC 60947-1 and IEC 60947-3 and shall be suitable for the application. In the US and Canada, disconnecting fuse holders can be used. Provide overcurrent protection and disconnecting device for supply conductors with approved current limiting devices suitable for protecting the wiring. If the equipment is used in a manner not specified by the manufacturer, the protection provided by the device may be impaired.

FCC PART 15 INFORMATION

NOTE: This equipment has been tested by the manufacturer and found to comply with the limits for a class B digital device, pursuant to part 15 of the FCC Rules. These limits are designed to provide reasonable protection against harmful interference when the equipment is operated in a residential environment. This equipment generates, uses, and can radiate radio frequency energy and, if not installed and used in accordance with the instruction manual, may cause harmful interference to radio communications. Operation of this equipment in a residential area may cause harmful interference in which case the user will be required to correct the interference at his own expense. Modifications to this product without the express authorization of the manufacturer nullify this statement.



INTRODUCTION

The EM3560 DIN Rail Power Meter provides a solution for measuring energy data with a single device. Inputs include Control Power, CT, and 3-phase voltage. The EM3560 supports BACnet MS/TP protocol, data logging, and pulse contact inputs. The LCD screen on the faceplate allows instant output viewing.

The meter is housed in a plastic enclosure suitable for installation on T35 DIN rail according to EN50022. The EM3560 can be mounted with any orientation over the entire ambient temperature range, either on a DIN rail or in a panel. The meter is not sensitive to CT orientation, reducing installation errors.

Parts of the EM Series

Figure 1 shows the parts of the EM Series Compact Power and Energy Meter.

Figure 1 EM Series Meter

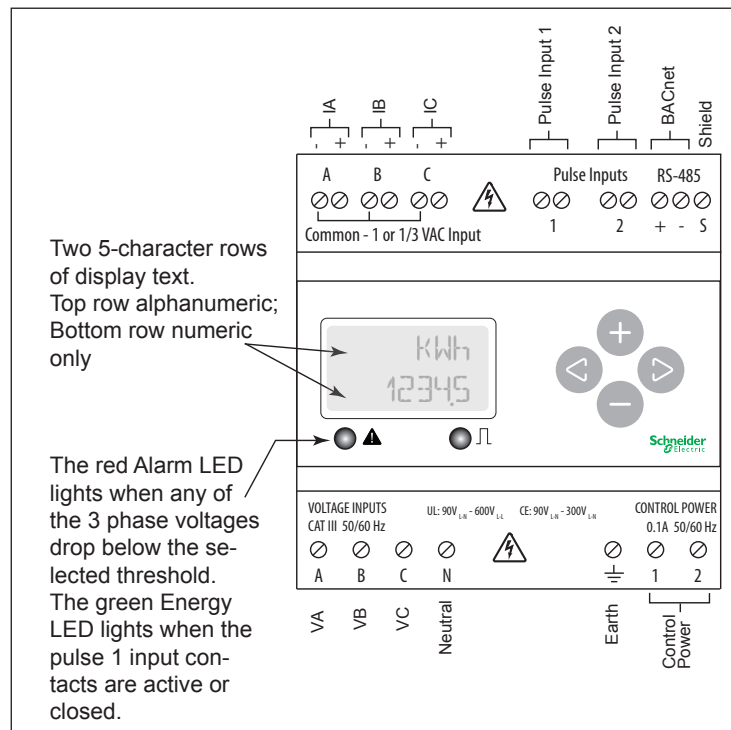

DIMENSIONS

Figure 2 EM Series Dimensions

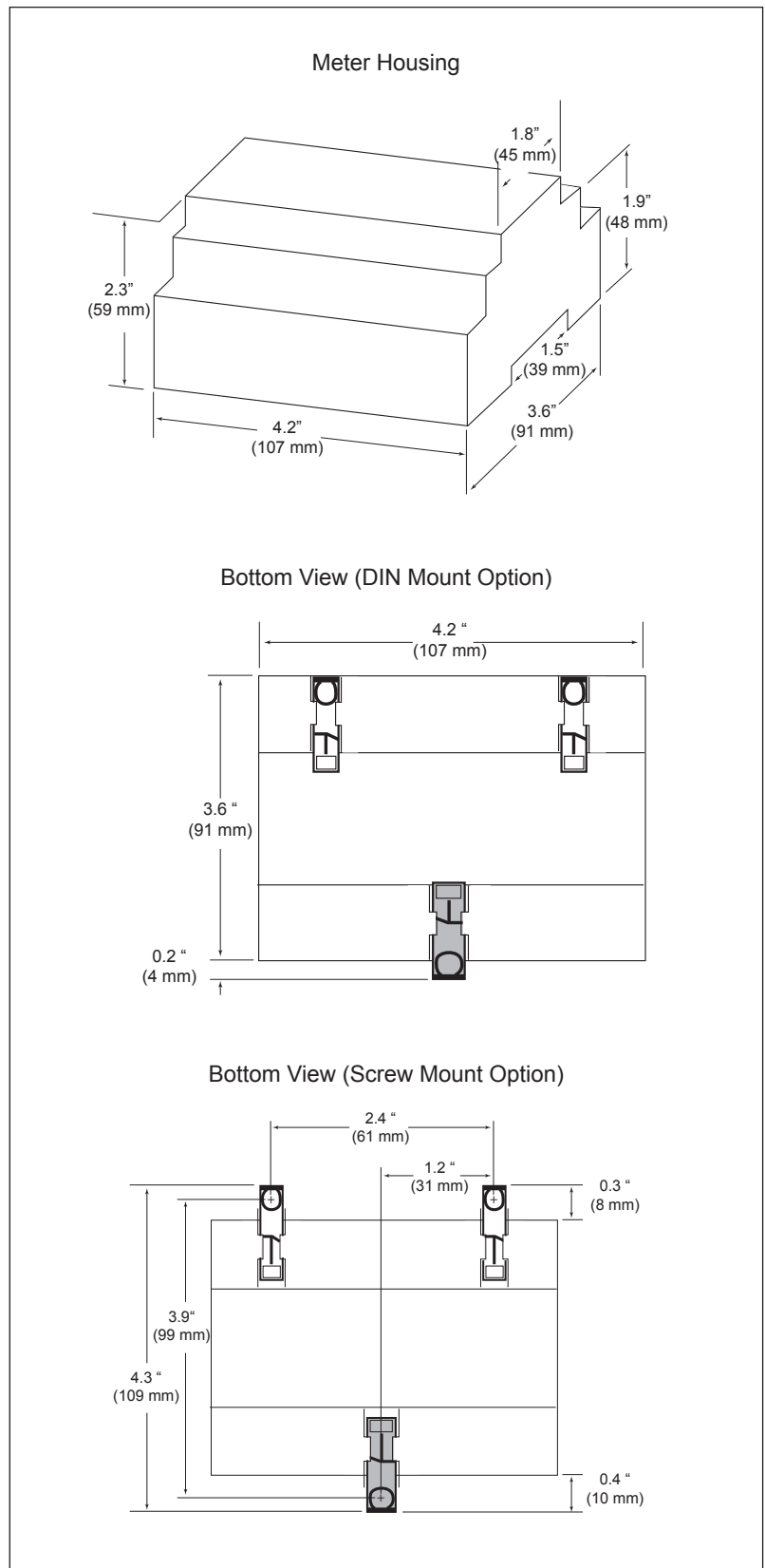

DATA OUTPUT

Table 2 Data Output

Full Data Set (FDS):
Power (kW)
Energy (kWh)
Configurable for CT & PT ratios, system type, and passwords
Diagnostic alerts
Current: 3-phase average
Volts: 3-phase average
Current: by phase
Volts: by phase line-line and line-neutral
Power: real, reactive, and apparent 3-phase total and per phase
Power Factor: 3-phase average and per phase
Frequency
Power Demand: most recent and peak
Demand Configuration: fixed, rolling block, and external sync
Data Logging:
Real Time Clock: uses BACnet time synchronization services
3 BACnet Log_Events: each buffer holds 5760 32-bit entries (user configures which 3 data points are stored in these buffers)
User configurable logging interval (when configured for a 15 minute interval, each buffer holds 60 days of data)
Continuous and Single Shot logging modes: user selectable
Auto write pause: read logs without disabling the meter's data logging mode

INSTALLATION

A. DIN Rail Mounting

The meter can be mounted in two ways: on standard 35 mm DIN rail or screw-mounted to the interior surface of the enclosure.

1. Disconnect and lock out power. Use a properly rated voltage sensing device to confirm power is off.
2. Attach mounting clips to the underside of the housing by sliding them into the slots from the inside. The stopping pegs must face the housing, and the outside edge of the clip must be flush with the outside edge of the housing.
3. Snap the clips onto the DIN rail. See diagram of the underside of the housing (Figure 3).

Figure 3 Attach mounting clips for DIN rail

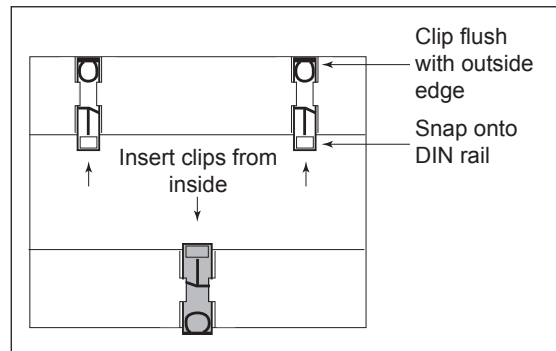

4. To prevent horizontal shifting across the DIN rail, use two end stop clips.

B. Screw Mounting

1. Disconnect and lock out power. Use a properly rated voltage sensing device to confirm power is off.
2. Attach the mounting clips to the underside of the housing by sliding them into the slots from the outside. The stopping pegs must face the housing, and the screw hole must be exposed on the outside of the housing.
3. Use three #8 screws (not supplied) to mount the meter to the inside of the enclosure. See diagram of the underside of the housing (Figure 4).

Figure 4 Attach clips for screw mounting

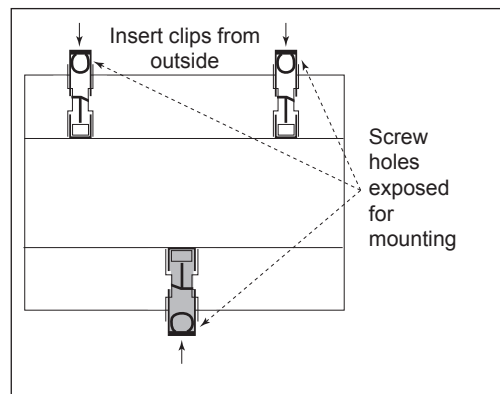

SUPPORTED SYSTEM TYPES

The EM3560 power meters have a number of different possible system wiring configurations (see Wiring Diagrams, page 5). To configure the meter, set the System Type via the User Interface or by writing the Present_Value of AV2 with the System Type value in the table below. The System Type tells the meter which of its current and voltage inputs are valid, which are to be ignored, and if neutral is connected. Setting the correct System Type prevents unwanted energy accumulation on unused inputs, selects the formula to calculate the Theoretical Maximum System Power, and determines which phase loss algorithm is to be used. The phase loss algorithm is configured as a percent of the Line-to-Line System Voltage (except when in System Type 10) and also calculates the expected Line to Neutral voltages for system types that have Neutral (12 & 40).

Values that are not valid in a particular System Type will display as “----” on the User Interface or as QNAN in the BACnet objects.

Table 3 Supported System Types

Number of wires	CTs		Voltage Connections			System Type		Phase Loss Measurements			Wiring Diagram
	Qty	ID	Qty	ID	Type	BACnet object AV2	User Interface: SETUP>S SYS	VLL	VLN	Balance	Diagram number
Single-Phase Wiring											
2	1	A	2	A, N	L-N	10	1L + 1n		AN		1
2	1	A	2	A, B	L-L	11	2L	AB			2
3	2	A, B	3	A, B, N	L-L with N	12	2L + 1n	AB	AN, BN	AN-BN	3
Three-Phase Wiring											
3	3	A, B, C	3	A, B, C	Delta	31	3L	AB, BC, CA		AB-BC-CA	4
4	3	A, B, C	4	A, B, C, N	Grounded Wye	40	3L + 1n	AB, BC, CA	AN, BN, CN	AN-BN-CN & AB-BC-CA	5, 6

WIRING

⚠ DANGER





HAZARD OF ELECTRIC SHOCK, EXPLOSION, OR ARC FLASH

- Apply appropriate personal protective equipment (PPE) and follow safe electrical work practices. See NFPA 70E in the USA or applicable local codes.
- This equipment must only be installed and serviced by qualified electrical personnel.
- Turn off all power supplying equipment before working on or inside the equipment.
- Always use a properly rated voltage sensing device to confirm power is off.
- Read, understand, and follow the instructions before installing this product.

Failure to follow these instructions will result in death or serious injury.

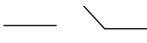
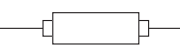
To avoid distortion, use parallel wires for control power and voltage inputs.
The following symbols are used in the wiring diagrams on the following pages.

Table 4 Wiring Symbols

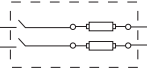
Symbol	Description
	Voltage Disconnect Switch
	Fuse (installer is responsible for ensuring compliance with local requirements. No fuses are included with the meter.)
	Earth ground
	Current Transducer
	Potential Transformer
	Protection device containing a voltage disconnect switch with a fuse or disconnect circuit breaker. The protection device must be rated for the available short-circuit current at the connection point.

CAUTION

RISK OF EQUIPMENT DAMAGE

- This product is designed only for use with 1V or 0.33V current transducers (CTs).
- DO NOT USE CURRENT OUTPUT (e.g. 5A) CTs ON THIS PRODUCT.

Failure to follow these instructions can result in overheating and permanent equipment damage.

WIRING DIAGRAMS

WARNING

RISK OF ELECTRIC SHOCK

CT negative terminals are referenced to the meter's neutral and may be at elevated voltages

- Do not contact meter terminals while the unit is connected
- Do not connect or short other circuits to the CT terminals

Failure to follow these instructions can result in death or serious injury.

Diagram 1: 1-Phase Line-to-Neutral 2-Wire System 1 CT

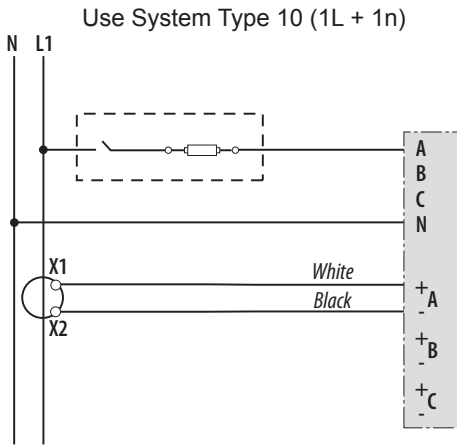

Diagram 2: 1-Phase Line-to-Line 2-Wire System 1 CT

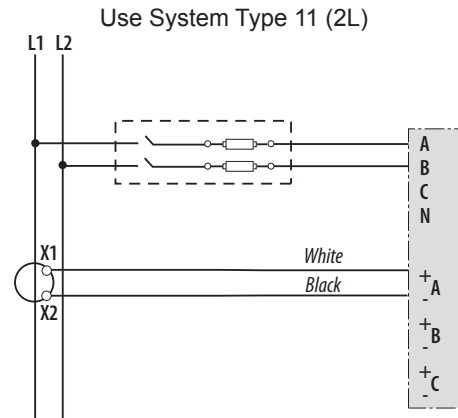

Diagram 3: 1-Phase Direct Voltage Connection 2 CT

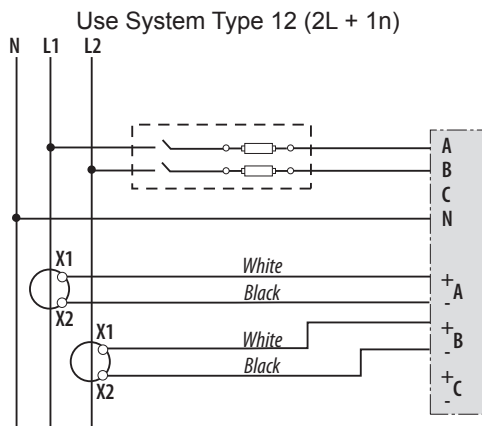

Diagram 4: 3-Phase 3-Wire 3 CT no PT

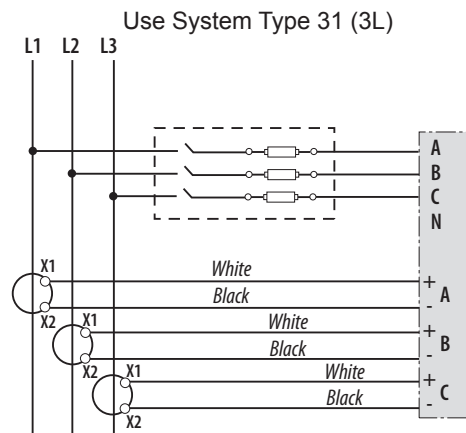

Diagram 5: 3-Phase 4-Wire Wye Direct Voltage Input Connection
3 CT

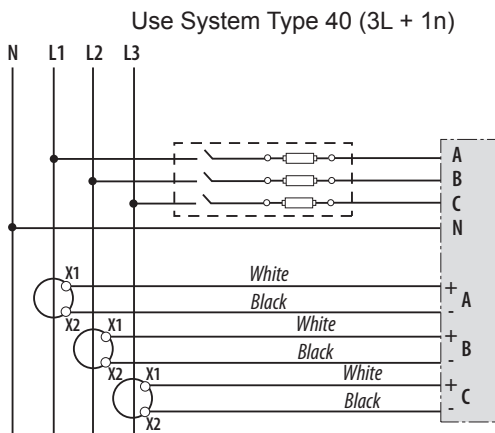
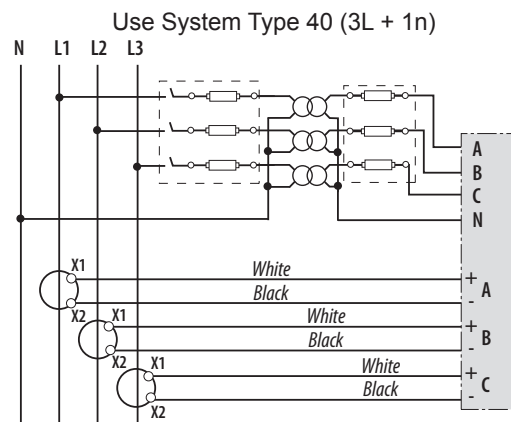
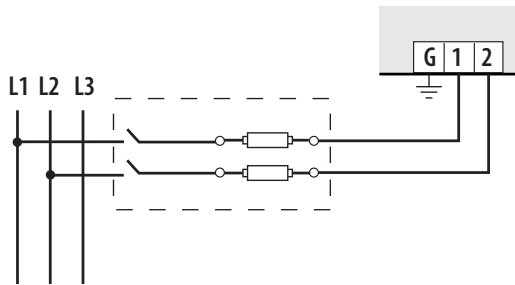

Diagram 6: 3-Phase 4-Wire Wye Connection 3 CT 3 PT



CONTROL POWER

Direct Connect Control Power (Line to Line)



Line to Line from 90VAC to 600 VAC (UL) (520 VAC for CE). In UL installations the lines may be floating (such as a delta). If any lines are tied to an earth (such as a corner grounded delta), see the Line to Neutral installation limits. In CE compliant installations, the lines must be neutral (earth) referenced at less than 300 VAC_{L-N}.

Direct Connect Control Power (Line to Neutral)

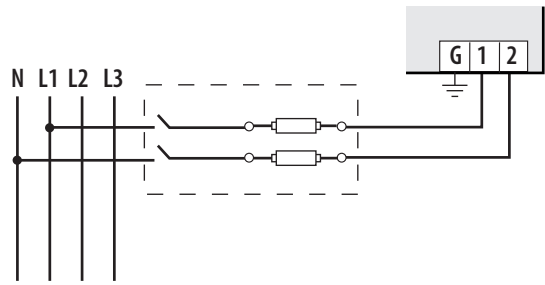

Line to Neutral from 90 VAC to 347 VAC (UL) or 300 VAC (CE)

Direct Connect Control Power (DC Control Power)

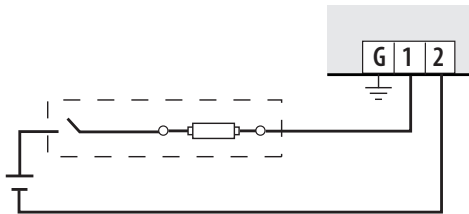

DC Control Power from 125 VDC to 300 VDC (UL and CE max.)

Control Power Transformer (CPT) Connection

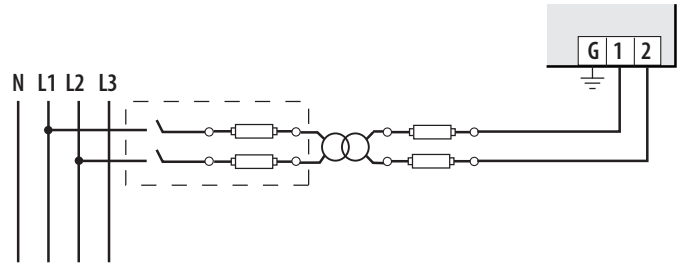

The Control Power Transformer may be wired L-N or L-L. Output to meet meter input requirements

FUSE RECOMMENDATIONS

Keep the fuses close to the power source (obey local and national code requirements).

For selecting fuses and circuit breakers, use the following criteria:

- Select current interrupt capacity based on the installation category and fault current capability.
- Select over-current protection with a time delay.
- The voltage rating should be sufficient for the input voltage applied.
- Provide overcurrent protection and disconnecting means to protect the wiring. For DC installations, external circuit protection must be provided. Suggested: 0.5 Amp AC time delay high interrupt capability fuses.
- The earth connection is required for electromagnetic compatibility (EMC) and is not a protective earth ground.

WIRING NOTES

- Use 14-24 gauge wire for all connections.
- When tightening terminals, ensure that the correct torque is applied: 3.5 - 4.4 in-lb (0.4-0.5 N·m).

DISPLAY SCREEN DIAGRAM

Figure 5 Display Screen

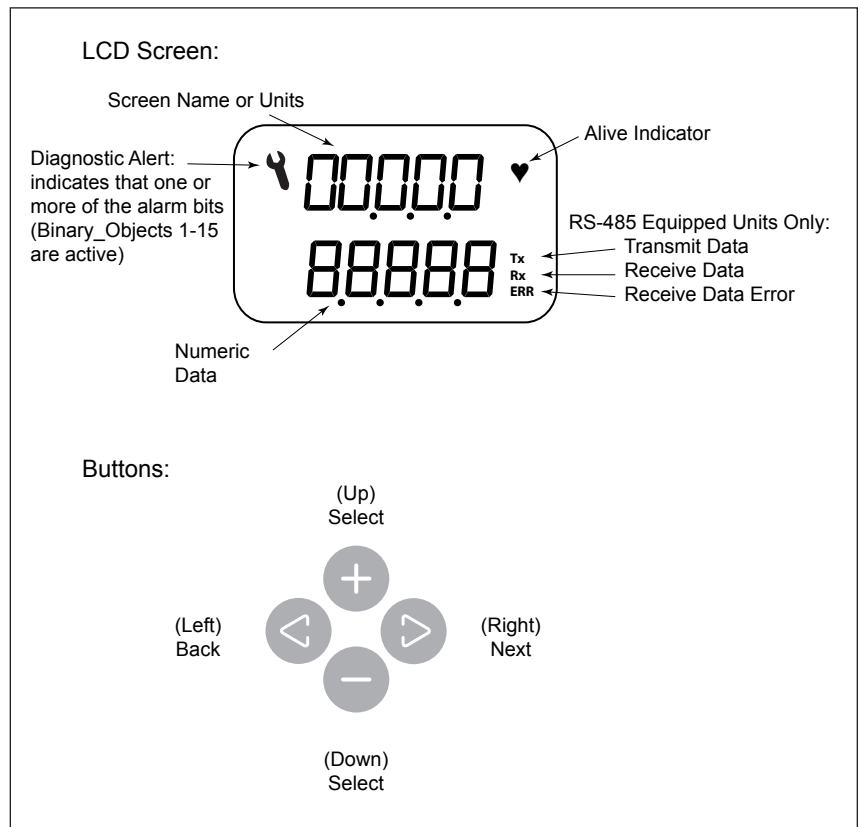

QUICK SETUP INSTRUCTIONS

Use this section to enter:

- BACnet communication parameters
- CT (Current Transducer) output voltage and input current ranges
- The service type to be monitored

These instructions assume the meter is set to factory defaults. If it has been previously configured, all optional values should be checked.

To Navigate to the Setup screens:

1. Press **+** or **-** repeatedly until **SETUP** screen appears.
2. Press **▶** to get to the **PSWD** screen.
3. Press **▶** to move through the digits. Use the **+** or **-** buttons to enter your password (the default is 00000).
4. Press **▶** to move to the first Setup screen (**S BAC**)
5. Use **+** or **-** to select the parameter screen you want to set.
6. After you set the parameters you want, use **+** or **-** to select the next Setup screen or **◀** to exit the Setup screens (return to **SETUP**).

To Enter BACnet communication parameters

1. Navigate to the **S BAC** (set BACnet) Setup screen (see section A above).
2. Press **▶** to go to the **MAC** screen and through the address digits. Use **+** or **-** to select the BACnet MAC address (default is 001).
3. Press **▶** to accept the value and go to the **BAUD** screen. Use **+** or **-** to select the baud rate (default is 768K).
4. Press **▶** to go to the **ID1** screen and through the upper four digits of the Device Instance. Use **+** or **-** to select the ID digits. The setup screen splits the Device ID into two parts, the most significant four digits (ID1) and the least significant three digits (ID2). The EM3560 supports BACnet Device ID values from 1 to 4,193,999. Units are shipped with a factory default setting that is pseudo-randomly generated in the range from 1,000,000 to 3,097,151.
5. Press **▶** to accept the value and go to the **ID2** screen and through the lower three digits of the Device Instance. Use **+** or **-** to select the ID digits.
6. Press **▶** to accept the value and go back to the **S BAC** screen.

To Enter the CT (Current Transducer) output voltage and input current ranges:

1. Navigate to the **S CT** (Set Current Transducer) Setup screen (see section A above).
2. Press **▶** to go to the **CT V** screen. Use **+** or **-** to select the voltage mode Current Transducer output voltage (default is 033).
3. Press **▶** to go to the **CT SZ** screen and through the digits. Use **+** or **-** to select the CT size in amps (default is 100). accept the value and
4. Press **▶** to accept the value and go back to the **S CT** screen.

To Enter the service type to be monitored:

1. Navigate to the \mathbb{S} $\mathbb{S}\mathbb{S}$ (Set System) Setup screen (see section A above).
2. Press \mathbb{S} to go to the $\mathbb{S}\mathbb{S}\mathbb{T}\mathbb{M}$ screen. Use \oplus or \ominus to select the configuration (see wiring diagrams - default is $\mathbb{S}\mathbb{L}\mathbb{N}$ - \mathbb{N}).
3. Press \mathbb{S} to go back to the \mathbb{S} $\mathbb{S}\mathbb{S}$ screen. For full setup instructions, see the configuration instructions on the following pages.

PULSE CONTACT INPUTS

The EM3560 has two inputs with pulse accumulators for solid state or mechanical contacts in other sensors, such as water or gas flow meters. These inputs are isolated from the measured circuits and referenced to the communication signal ground. Use with contacts that do not require current to remove oxidation.

Figure 6 Pulse Contact Inputs

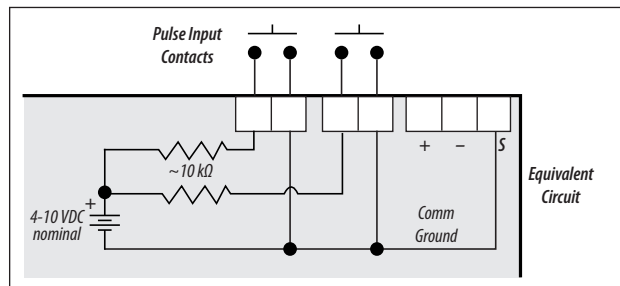

UI MENU ABBREVIATIONS DEFINED

The user can set the display mode to IEC or IEEE notation in the SETUP menu.

Table 5 IEC and IEEE Abbreviations

Main Menu		
IEC	IEEE	Description
D	D	Demand
MAX	M	Maximum Demand
P	W	Present Real Power
Q	VAR	Present Reactive Power
S	VA	Present Apparent Power
A	A	Amps
UAB, UBC, UAC	VAB, VBC, VAC	Voltage Line-to-Line
V	VLN	Voltage Line-to-Neutral
PF	PF	Power Factor
U	VLL	Voltage Line-to-Line
HZ	HZ	Frequency
KSh	KVAh	Accumulated Apparent Energy
KQh	KVARh	Accumulated Reactive Energy
KPh	KWh	Accumulated Real Energy
PLOSS	PLOSS	Phase Loss
LOWPF	LOWPF	Low Power Factor Error
F ERR	F ERR	Frequency Error
I OVR	I OVR	Over Current
V OVR	V OVR	Over Voltage
PULSE	PULSE	kWh Pulse Output Overrun (configuration error)
_PHASE	_PHASE	Summary Data for 1, 2, or 3 active phases
ALERT	ALERT	Diagnostic Alert Status
INFO	INFO	Unit Information
MODEL	MODEL	Model Number
OS	OS	Operating System
RS	RS	Reset System
SN	SN	Serial Number
RESET	RESET	Reset Data
PASWD	PASWD	Enter Reset or Setup Password
ENERG	ENERG	Reset Energy Accumulators
DEMND	DEMND	Reset Demand Maximums
↑		Import
↓		Export
PULS_	PULS_	Pulse Counter (if equipped)

USER INTERFACE FOR DATA CONFIGURATION

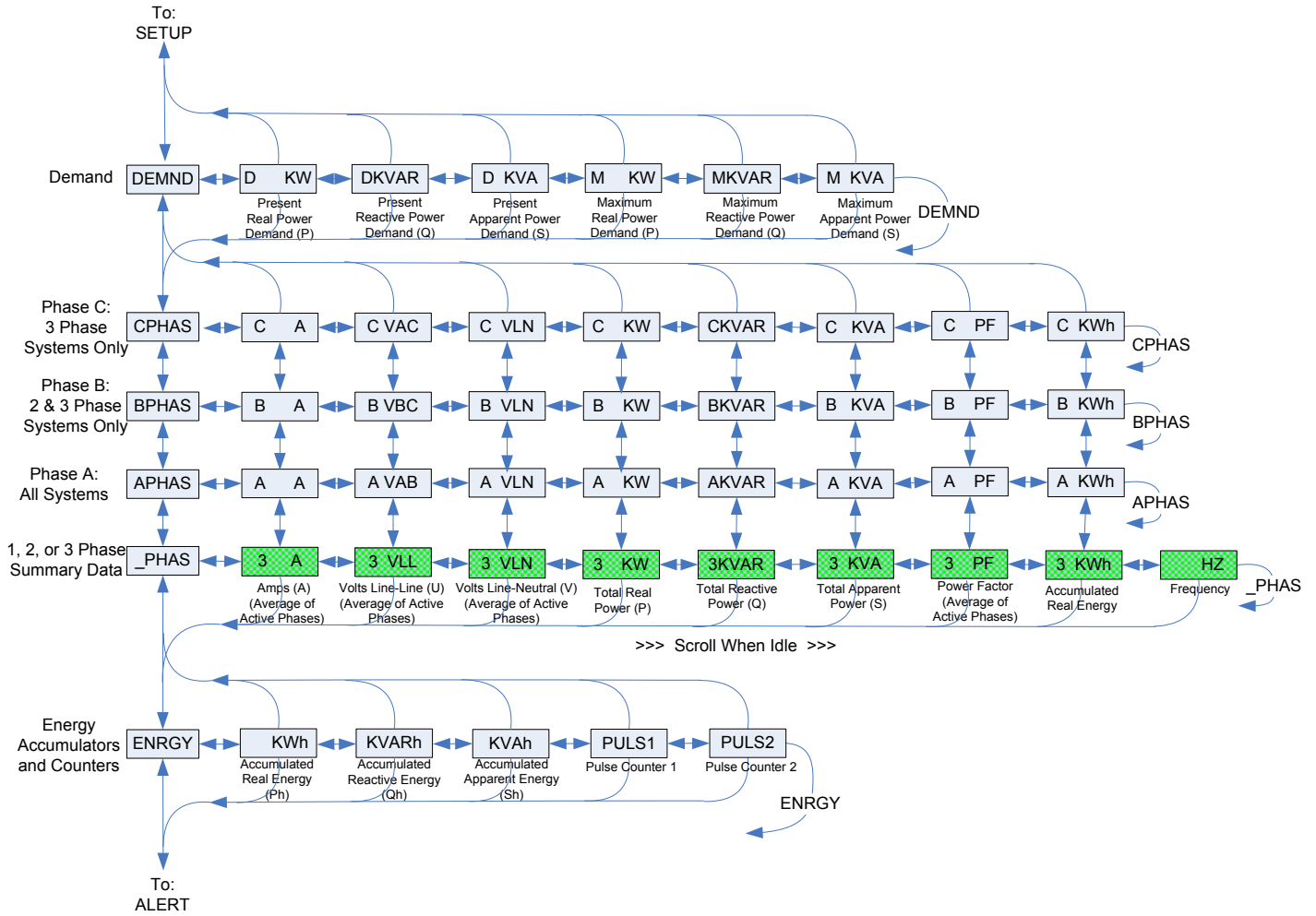

USER INTERFACE FOR ALERTS

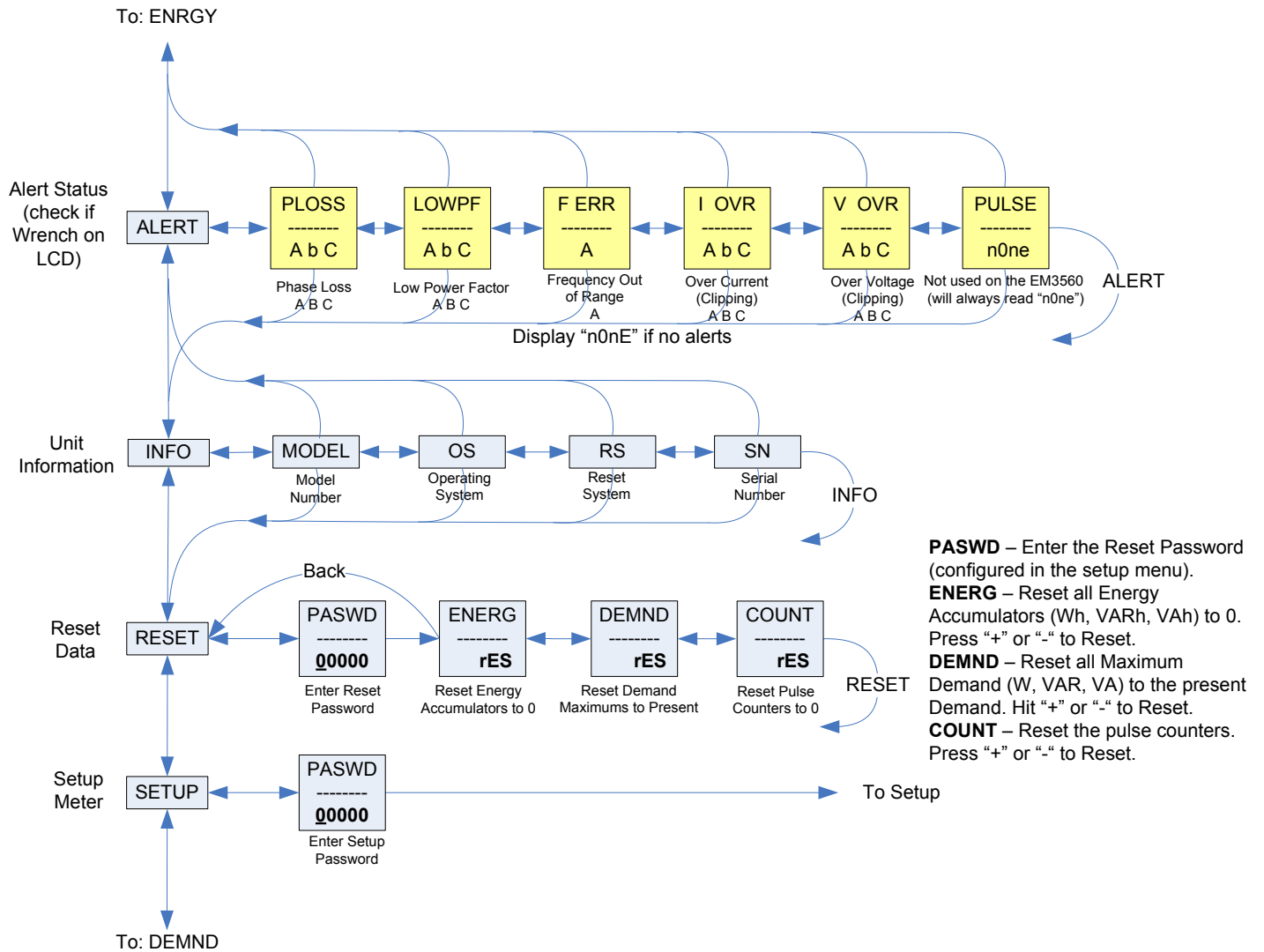

USER INTERFACE FOR SETUP

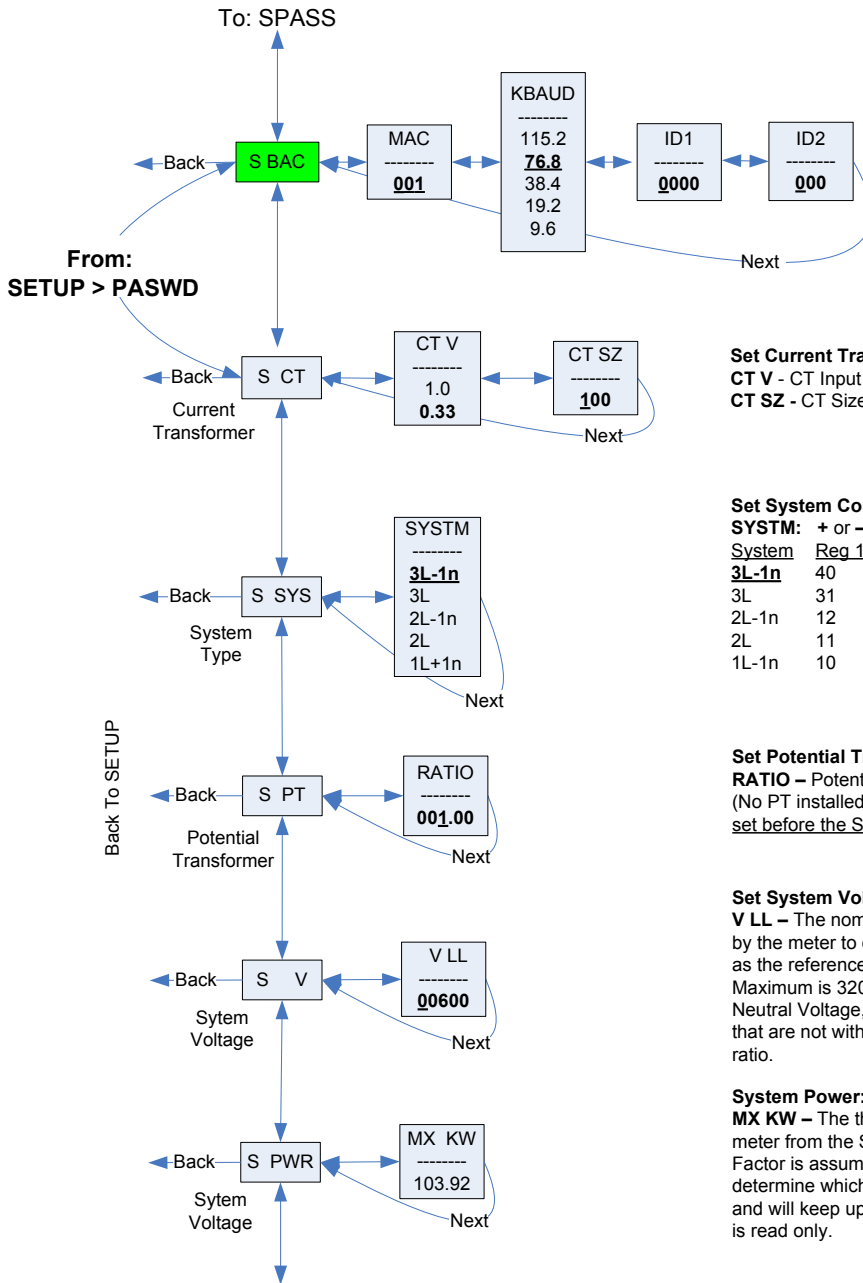

Set Communications Parameters:
ADDR – BACnet MS/TP MAC Address: 0 – 127.
 Press + to increment the selected (blinking) digit.
 Press - to select the digit to the left.
BAUD - Baud Rate: 9600 – 115200 Baud
BACnet ID: These two screens set the 7 digit BACnet device ID. Screen ID1 is the most significant 4 digits and ID2 the least significant three digits. This is in the range of 0 - 4,194,302.

Set Current Transducer:
CT V - CT Input Voltage: + or - to Select 1.0 or .33V.
CT SZ - CT Size: in Amps. Maximum is 32000 Amps.

Set System Configuration:
SYSTEM: + or - to step through the following System Type options:

System	Reg 130	CTs	Description
3L-1n	40	3	Wye Three Phase: A, B, & C with Neutral (Default).
3L	31	3	Delta Three Phase: A, B & C; no Neutral
2L-1n	12	2	Single Split Phase: A & B with Neutral
2L	11	1	Single Phase: A & B; no Neutral
1L-1n	10	1	Single Phase: A to Neutral

Set Potential Transformer Ratio:
RATIO – Potential transformer step down is RATIO:1. Default is 1:1 (No PT installed). See Install for wiring diagrams. This value must be set before the System Voltage (if used).

Set System Voltage:
V LL – The nominal Line to Line Voltage for the system. This is used by the meter to calculate the theoretical maximum system power, and as the reference voltage for setting the Phase Loss threshold. Maximum is 32000 Volts. For system type 1+N (10), this is a Line to Neutral Voltage, indicated by "V LN". Note: the meter will reject settings that are not within the meter's operating range when divided by the PT ratio.

System Power:
MX KW – The theoretical Maximum System Power is calculated by the meter from the System Voltage, CT size, and System Type. Power Factor is assumed to be unity. The value of System Power is used to determine which combinations of pulse weight and duration are valid and will keep up with the maximum power the meter will see. This value is read only.

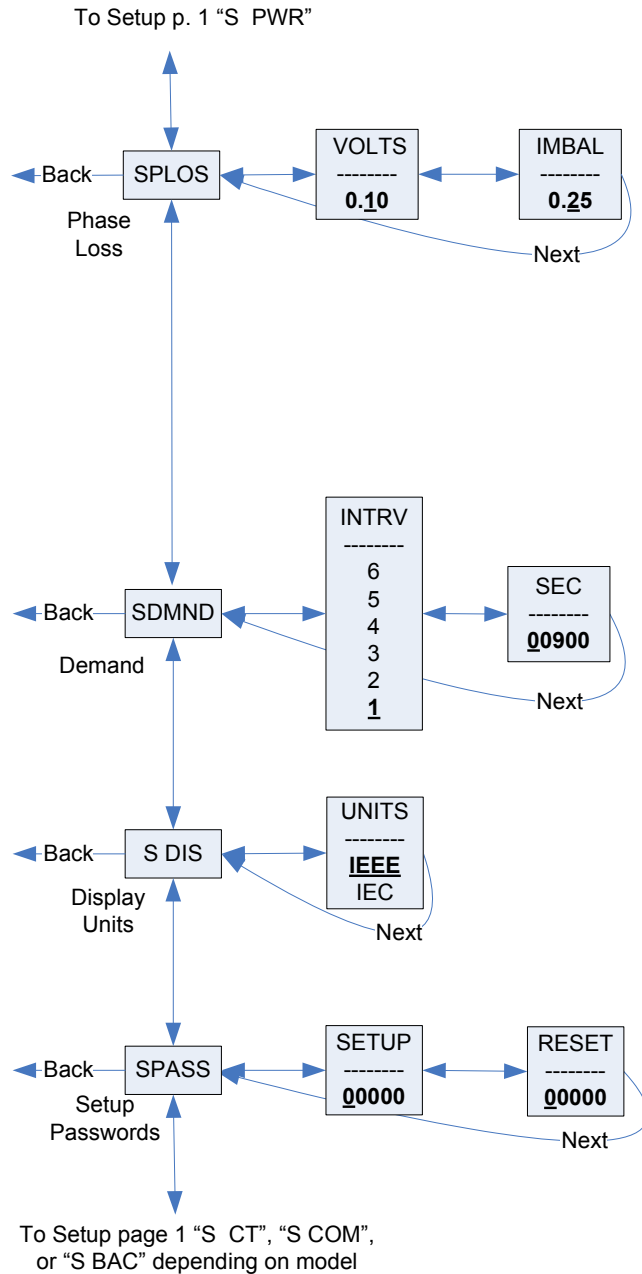

Set Phase Loss:

VOLTS - Phase Loss Voltage: The fraction of the system voltage below which Phase Loss Alarm is on. For system types with neutral, the Line to Neutral voltage is also calculated and tested. If the System Voltage is 600 and the fraction is set to 0.10, then the Phase Loss threshold will be 60 volts.

IMBAL - Phase Loss Imbalance: The fractional difference in Line to Line voltages above which Phase Loss Alarm is on. For system types with neutral, the Line to Neutral voltages are also tested. For system types 1+N (10) and 2 (11), imbalance is not tested.

Set Demand Interval:

INTRV - The number of Sub-Intervals (1 to 6) in a Demand Interval. Default is 1 (block demand).

SEC - Sub-Interval length in seconds. Default is 900 (15 minutes). Set to 0 for external sync-to-comms.

Set Display Units: +/- to switch between:

IEEE - VLL VLN W VAR VA Units.

IEC - U V P Q S Units.

Set Passwords:

SETUP - The Password to enter the SETUP menu.

RESET - The Password to enter the RESET menu.

RS-485 COMMUNICATIONS

Daisy-chaining Devices to the Power Meter

The RS-485 slave port allows the power meter to be connected in a daisy chain with up to 63 2-wire devices. In this bulletin, communications link refers to a chain of devices that are connected by a communications cable.

Figure 7 Daisy-chaining multiple devices

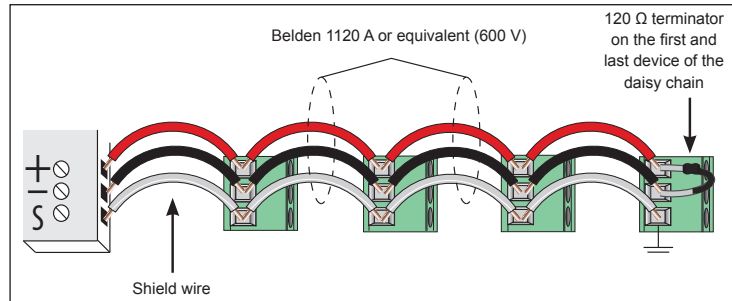

- The terminal's voltage and current ratings are compliant with the requirements of the EIA RS-485 communications standard.
- The RS-485 transceivers are $\frac{1}{4}$ unit load or less.
- RS-485+ has a 47 k Ω pull up to +5V, and RS-485- has a 47 k Ω pull down to Shield (RS-485 signal ground).
- Wire the RS-485 bus as a daisy chain from device to device, without any stubs. Use 120 Ω termination resistors at each end of the bus (not included).
- Shield is not internally connected to Earth Ground.
- Connect Shield to Earth Ground somewhere on the RS-485 bus.
- Use 14-24 gauge wire for all connections.
- When tightening terminals, ensure that the correct torque is applied: 3.5 - 4.4 in-lb (0.4-0.5 N·m).

Figure 8 Torque requirements

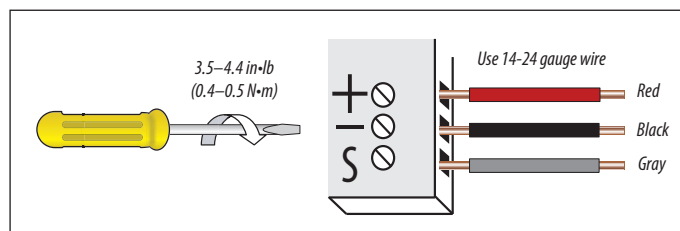

BACNET DEFAULT SETTINGS

Table 6 BACnet Defaults

Setting	Default Value*	BACnet Object
Setup Password	00000	n/a
Reset Password	00000	n/a
System Type	40 (3 + N) Wye	AV2
CT Primary Ratio	100 A	AV3
CT Secondary Ratio	0.33 V	AV4
PT Ratio	1:1 (none)	AV5
System Voltage	600 V L-L	AV6
Max. Theoretical Power	Calculated from AV2, AV3, AV5 & AV6 (with all default settings, this would be 103.92 kW)	AI45
Display Mode	1 (IEEE Units)	AV7
Phase Loss Voltage Threshold	10% of System Voltage	AV8
Phase Loss Voltage Threshold	25% Phase to Phase Imbalance	AV9
Demand: number of subintervals per interval	1 (block mode)	AV10
Demand: sub-interval length	900 sec (15 min) (AV11 default value is 90000 [1/100 seconds])	AV11
BACnet MAC Address	001	n/a
BACnet MS/TP Baud Rate	76.8 kBaud	n/a
BACnet MS/TP Max_Master	127	Device
BACnet Device_ID	Pseudo-random value from 1,000,000 to 3,097,151	Device
BACnet Device Location	Installed location not yet identified	Device
Trend_Log Object 1 Log_Device_Object_Property	AI1 (Real Energy)	TL1
Trend_Log Object 2 Log_Device_Object_Property	AI27 (Reactive Energy)	TL2
Trend_Log Object 3 Log_Device_Object_Property	AI34 (Total Real Present Demand)	TL3

* Default values are preset at the factory. Once changed, there is no way to automatically reset defaults. They must be restored individually. The baud rate and MAC address are set through the user-interface screens, and the others are set by re-writing each Object (see BACnet Programming Information section, next page).

BACNET PROGRAMMING INFORMATION

The EM3560 is programmable via BACnet protocol and can easily be connected to a BACnet IP network using an off-the shelf BACnet router. It uses five types of BACnet objects. A standard PICS (below) describes the required characteristics of the BACnet implementation, but this additional descriptive context may be helpful to the integrator.

In addition to the required properties, the device object utilizes some optional properties to support other functionality, Time Synchronization (primarily used for data/trend logging on the device) and Description and Location properties to simplify installation and maintenance. Configure all of the meter's functions, other than Data Logging and writable Device Properties, by writing the Present_Value of the 11 Analog_Value objects. These values (except for the configuration register, AV1, which will always return zero when read) are all readable and stored in nonvolatile memory so that they are retained if power to the device is interrupted.

Data values other than log information and alerts are all accessed by reading the Present_Value of the 52 Analog_Input objects. Most of these values are instantaneous readings of measured service parameters. Some of them, (AI1, AI26, AI27, AI37-AI45, AI47, AI50 and AI51) represent accumulated values and are stored in nonvolatile memory as well. If power to the device is interrupted, these values are retained, but no additional information is accumulated until the device completes its re-initialization.

Alerts are used to indicate conditions of potential concern to the installer or the system, such as input voltage or current on any phase that exceeds the meter's measurement range, phase voltage below the Phase Loss Threshold set by the user, or Power Factor below 0.5 on any phase. Alerts are accessible by reading the Present_Value of the 15 Binary_Input objects, or as a group by reading the Present_Value of Analog_Input object 52. Alerts are not latched and do not generate events to system. They indicate presence of these conditions at the time they are read, but the device does not latch and store them until they are read (if the condition changes before they are read, the alert will go away).

All Analog_Value, Analog_Input, and Binary_Input objects implement the reliability property and use it to indicate that the Present_Value properties are functional, valid and current. For complete assurance, check the Reliability property for a No_Fault_Detected status before reading the Present_Value of any AV, AI or BI objects.

Data Logging is implemented using three Trend_Log objects, which are described in more detail in the section on Data Logging.

BACNET PROTOCOL IMPLEMENTATION CONFORMANCE STATEMENT (PICS)

Date: Feb 1, 2011
Vendor Name: Schneider Electric
Product Name: EM3560 Energy Meter
Product Model Number: EM3560
Applications Software Version: 1
Firmware Revision: x.xxx
BACnet Protocol Revision: 4
Product Description: 3-phase electrical energy meter

BACnet Standardized Device Profile (Annex L): BACnet Application Specific Controller (B-ASC)

List all BACnet Interoperability Building Blocks Supported (Annex K): DS-RP-B, DS-RPM-B, DS-WP-B, DM-DDB-B, DM-DOB-B, DM-DCC-B, T-VMT-I-B, DM-TS-B

Segmentation Capability: Segmentation not supported

Standard Object Types Supported: No dynamic Creation or Deletion supported; no proprietary properties or object types

1. Device Object:

- Optional Properties Supported: Max_Master, Max_Info_Frames, Description, Location, Local_Time, Local_Date
- Writable Properties: Object_Identifier, Object_Name, Max_Master, Location
- Property Range Restrictions: Object_Identifier – May only write values from 1 to 4,193,999; Location – (limited to 64 characters); Max_Master – May only write values from 1 to 127

2. Analog_Input Object:

- Optional Properties Supported: Description, Reliability
- No Writable Properties.

3. Analog_Value Object:

Optional Properties Supported: Description, Reliability

Writable Properties: Only the Present_Value is writable.

Property Range Restrictions:

- AV1: May only write 30078, 21211, 21212, and 16498.
- AV2: May only write 10, 11, 12, 31 and 40.
- AV3: May only write values from 5 to 32000.
- AV4: May only write values 1 and 3.
- AV5: May only write values from 0.01 to 320.0
- AV6: May only write values such that AV6/AV5 is from 82 to 660 (absolute range is 82-32000). To ensure AV6 accepts/rejects the proper values, AV5 should be set (written) first.
- AV7: May only write values 0 and 1.
- AV8: May only write values from 1 to 99.
- AV9: May only write values from 1 to 99.
- AV10: May only write values from 1 to 6.
- AV11: May only write the value 0 or a value from 1000 to 3276700 in multiples of 100.

Note that all accumulated values (AI1, AI26-27, AI37-45, AI47 and AI50-51) and the Record_Count of the TrendLogs (TL1 to TL3) will be reset when this object is written.

4. Binary_Input Object:

- Optional Properties Supported: Description, Reliability
- No Writable Properties

5. Trend_Log Object:

- Optional Properties Supported: Description,
- Writable Properties: Log_Enable, Start_Time, Stop_Time, Log_DeviceObjectProperty, Log_Interval, Stop_When_Full, Record_Count
- Property Range Restrictions:
- Log_DeviceObjectProperty: May only be set to the Present_Value of local objects AI1 through AI44 (only the Present_Value of objects AI1 through AI44 may be logged).
- Log_Interval: May only write the value 0 or values from 1000 to 3276700 in multiples of 100.

Data Link Layer Options: MS/TP master (Clause 9), baud rate(s): 9600, 19200, 38400, 76800, 115200

Device Address Binding: Static device binding is not supported. (No client functionality is included).

Networking Options: None

Character Sets Supported: ANSI X3.4

Legend

R/W R=read only; R/W=read or write

NV Value is stored in non-volatile memory. The value will still be available if the meter experiences a power loss and reset.

Units Lists the physical units that a register holds.

Device Object

Property	R/W	NV	Value Returned	Additional information
Object_Identifier	R/W	NV	Device<n>	n is the 7 digit ID # set in the ID1 & ID2 Setup screens on the meter. The BACnet Device ID is a Decimal number from 1 to 4,193,999 that can be entered or viewed on the user screens or through this property. The default value set at the factory is a pseudo-random number from 1,000,000 to 3,097,151 to reduce the likelihood of conflicts if multiple units are installed using their default IDs.
Object_Type	R	NV	Device (8)	
Object_Name	R	NV	Schneider EM Series Energy Meter - S/N: <serial number>	
Vendor_Name	R	NV	Schneider Electric	
Vendor_Identifier	R	NV	133	
Model_Name	R	NV	EM3560 Energy Meter	
Firmware_Revision	R	NV	<Current Revision #>	"xyyy". This is the BACnet processor firmware version in the format <xyyy>, with an implied decimal point between the first two digits (x.yyy)
Application_Software_Version	R	NV	<Current version #>	"RS= xyyy, OS=xyyy, BACnet Gateway=xyyy" The format <xyyy> has an implied decimal point between the first two digits (x.yyy)
Location	R/W	NV	<Location>	Limited to 64 Characters - Default value is "Installed location not yet identified"
Description	R	NV	Schneider EM3560 DIN-Rail Energy Meter S/N <serial number>	

Property	R/W	NV	Value Returned	Additional information
Protocol_Version	R	NV	1	BACnet Protocol Version 1.
Protocol_Revsion	R	NV	4	BACnet Protocol Revision 4.
Local_Date	R		Date	Set via BACnet Time Synchronization only - reverts to Jan 1, 2000 if control power drops.
Local_Time	R		Time	Set via BACnet Time Synchronization only - reverts to 12:00:00 AM if control power drops.
Segmentation_Supported	R	NV	NO_SEGMENTATION (3)	Segmentation is not supported.
Max_Master	R/W	NV	1-127 (Factory Default is 127)	Highest possible MAC Address for Master nodes on the local MS/TP network.
Max_Info_Frames	R	NV	1	Maximum number of information frames allowed before passing the MS/TP token.
Max_APDU_Length_Accepted	R	NV	480	
APDU_Timeout	R	NV	60000	
Number_of_APDU_Retries	R	NV	0	
System_Status	R	NV	Operational (0)	
Protocol_Sevices_Supported	R	NV	0b00000000000010110100000000000011110000	
Protocol_Object_Types_Supported	R	NV	0b101100001000000000001000000000	
Object_List	R	NV	DE1,AI1,AI2,AI3,AI4,AI5,AI6,AI7,AI8,AI9,AI10,AI11,AI12,AI13,AI14,AI15,AI16,AI17,AI18,AI19,AI20,AI21,AI22,AI23,AI24,AI25,AI26,AI27,AI28,AI29,AI30,AI31,AI32,AI33,AI34,AI35,AI36,AI37,AI38,AI39,AI40,AI41,AI42,AI43,AI44,AI45,AI46,AI47,AI48,AI49,AI50,AI51,AI52,AV1,AV2,AV3,AV4,AV5,AV6,AV7,AV8,AV9,AV10,AV11,BI1,BI2,BI3,BI4,BI5,BI6,BI7,BI8,BI9,BI10,BI11,BI12,BI13,BI14,BI15,TR1,TR2,TR3	
Device_Address_Binding	R	NV	∅	
Database_Revsion	R	NV	0	

Analog_Value Objects

Use the Present_Value property of the Analog_Value object for all writable variables in the meter other than those used specifically for BACnet configuration or Time Synchronization (in the Device Object) or Data Logging (in the Trend_Log object).

Values are checked when written, and errors are returned for invalid entries. This table describes how those variables are used by the meter, what values are valid, what their defaults are, and how to use them. When writing values to the Present_Value properties of Analog_Value BACnet objects, there can be a delay of up to about two seconds to validate and store the new value. An immediate read of the same property before that delay has elapsed can return the prior value (even if the new value was accepted). To read a value immediately after it is written, check the Reliability property first. When it reports a No_Fault_Detected status, the Present_Value of the object will be current.

These objects support the Description and Reliability object properties and all required Analog_Value object properties, but Present_Value is the only writable property.

#	Name	Description	R/W	NV	Units	Range	Factory Default Value	Additional information
AV1	Config	Configuration	R/W		n/a	n/a	Always returns "0" when read	Command Register: - Write 30078 (0x757E) to clear all energy accumulators to 0 (All). - Write 21211 (0x52DB) to begin new Demand Sub-Interval calculation cycle and log another data value on Trend_Log objects TL1-TL3 (when the meter is in Manual "Sync-to Comms" mode). This takes effect at the end of the next 1 second calculation cycle. Write no more frequently than every 10 seconds. - Write 21212 (0x52DC) to reset Max Demand values to Present Demand Values. Takes effect at the end of the next 1 second calculation cycle. Write no more frequently than every 10 seconds. - Write 16498 (0x4072) to clear pulse counters to 0.
AV2	System_Type	System Type	R/W	NV	n/a	40, 31, 12, 11, 10	40	System_Type: - Write 10 for Single-Phase: A + N - Write 11 for Single-Phase: A + B - Write 12 for Split-Phase: A + B + N - Write 31 for 3-Phase : A + B + C, no N - Write 40 for 3-Phase Y: A + B + C + N
AV3	CT_Ratio_Primary	CT Ratio - Primary	R/W	NV	Amps	5-32000	100	Current Transducer Size - Primary Current Range (Default is set for 100A CTs)
AV4	CT_Ratio_Secondary	CT Ratio - Secondary	R/W	NV	1/Volts	1,3	1	Current Transducer Type – Secondary Interface - Enter 1 for CTs with 1V outputs (Default) - Enter 3 for CTs with 1/3V outputs
AV5	PT_Ratio	PT Ratio	R/W	NV	Value	0.01 - 320.0	1	Potential Transformer Ratio - The default is 1.00 (1:1), which is no PT attached. Set this value before setting the System Voltage (below).
AV6	System_Voltage	System Voltage	R/W	NV	Volts	from 82 (times the PT_Ratio in AV5) to 660 (times the PT_Ratio in AV5 - absolute limits are 82-32000)	600	System Voltage – This voltage is Line to Line unless in System Type 10 (in object AV2), in which case it is Line to Neutral. This value is used to by the meter to calculate the full scale power for the analog outputs and pulse configuration (see below), and as full scale for phase loss (in object AV8). Do not set the meter to voltages outside the range of 82-660 volts times the PT Ratio in object AV5.
AV7	Display_Units	Display Units	R/W	NV	n/a	0,1	1	Display Units: 0 = IEC (U, V, P, Q, S), 1 = IEEE (default: VLL, VLN, W, VAR, VA)

#	Name	Description	R/W	NV	Units	Range	Factory Default Value	Additional information
AV8	Phase_Loss_Voltage_Threshold	Phase Loss Voltage Threshold	R/W	NV	Percent	1-99	10	Phase Loss Voltage Threshold in percent of System Voltage (in object AV6). Default is 10 (10%). Any phase (as configured in AV2) whose level drops below this threshold triggers a Phase Loss alert - i.e. if the System voltage is set to 480 V L-L, the L-N voltage for each phase should be 277 V. When the threshold is set to 10%, if any phase drops more than 10% below 277 V, (less than 249 V), or if any L-L voltage drops more than 10% below 480 V (less than 432 V) the corresponding phase loss alarm bit will be true.
AV9	Phase_Loss_Imbalance_Threshold	Phase Loss Imbalance Threshold	R/W	NV	Percent	1-99	25	Phase Loss Imbalance Threshold in Percent. Default is 25% phase to phase difference. For a 3-phase Y (3 + N) system type (40 in object AV2), both Line to Neutral and Line to Line voltages are tested. In a 3-phase Δ System type (31 in object AV2), only Line to Line voltages are examined. In a single split-phase (2 + N) system type (12 in object AV2), just the line to neutral voltage are compared.
AV10	Subintervals	Number of Subintervals Per Demand Interval	R/W	NV		1-6	1	Number of Sub-Intervals per Demand Interval. Sets the number of sub-intervals that make a single demand interval. For block demand, set this to 1. Default is 1. When Sub-Interval Length (in object AV11) is set to 0 (sync-to-comms mode), the value of this object is ignored.
AV11	Subinterval_Length	Subinterval Length	R/W	NV	hundredths of a second	0, 10-32767	90000	Sub-Interval Length in hundredths of a second. For sync-to-comms mode, which allows manual triggering of demand intervals and the logging of another Trend_Log record, set this value to 0 and write 21211 to the reset register (object AV1) each time the sub-interval must be externally reset. Default is 90000 (15 minutes). This variable is tied directly to the Log_Interval property of all three Trend_Log objects (their value is always the same as this one). Changing any of these four properties will change all of them.

Analog_Input Objects

Use the Present_Value property of the Analog_Input objects for all read-only numeric variables in the meter other than those used specifically for device configuration (in the Device Object) or Data Logging (in the Trend_Log object).

These objects support the Description and Reliability object properties and all required Analog_Input object properties. None of them are writable. The values that are not instantaneous (i.e., Accumulated Energy, Max Demand, Pulse Input Counts) are non-volatile. They are not updated while Control Power is inactive, but their past values are retained when Control Power is restored.

For complete assurance, check the Reliability property for a No_Fault_Detected status before reading the Present_Value. If the line voltage or input frequency of the system being monitored falls out of the supported range, the corresponding alert bits (BI1-BI7) will be set and the reliability property of any values that cannot be accurately measured under those conditions will return Unreliable_Other.

#	Object_Name	Description	R/W	NV	Units	NA	Additional information
AI1	Energy	Real Energy Consumption	R	NV	kWh	0 - 3.4+E38	Resolution is limited by data type (when value exceeds 7 digits; reset more often to maximize resolution)
AI2	kW_Total	Total Real Power	R		kW	0 - Max_Power (AI45)	
AI3	kVAR_Total	Total Reactive Power	R		kVAR	0 - Max_Power (AI45)	
AI4	kVA_Total	Total Apparent Power	R		kVA	0 - Max_Power (AI45)	
AI5	PF_Total	Total Power Factor	R		Power Factor	0.00 - 1.00	1.00 for 100%

#	Object_Name	Description	R/W	NV	Units	NA	Additional information
AI6	Volts_LL_Avg	Voltage L-L Average	R		Volts		
AI7	Volts_LN_Avg	Voltage L-N Average	R		Volts		
AI8	Current_Avg	Current Average	R		Amps		
AI9	kW_A	Real Power Phase A	R		kW	0 - Max_Power (AI45)	
AI10	kW_B	Real Power Phase B	R		kW	0 - Max_Power (AI45)	
AI11	kW_C	Real Power Phase C	R		kW	0 - Max_Power (AI45)	
AI12	PF_A	Power Factor Phase A	R		Power Factor	0.00 - 1.00	1.00 for 100%
AI13	PF_B	Power Factor Phase B	R		Power Factor	0.00 - 1.00	1.00 for 100%
AI14	PF_C	Power Factor Phase C	R		Power Factor	0.00 - 1.00	1.00 for 100%
AI15	Volts_AB	Voltage Phase A-B	R		Volts		
AI16	Volts_BC	Voltage Phase B-C	R		Volts		
AI17	Volts_AC	Voltage Phase A-C	R		Volts		
AI18	Volts_AN	Voltage Phase A-N	R		Volts		
AI19	Volts_BN	Voltage Phase B-N	R		Volts		
AI20	Volts_CN	Voltage Phase C-N	R		Volts		
AI21	Current_A	Current Phase A	R		Amps		
AI22	Current_B	Current Phase B	R		Amps		
AI23	Current_C	Current Phase C	R		Amps		
AI24	Reserved_AI24	Reserved	R		n/a	QNAN	
AI25	Frequency	Frequency	R		Hz	45.0-65.0	Will return QNAN if frequency is out of range (or no voltage input present on Phase A)
AI26	kVAh	Apparent Energy Consumption	R	NV	kVAh	0 - 3.4+E38	The UNITS property of object AI26 will report that these units are kWh because there is no unit type in the BACnet standard for kVAh.
AI27	kVARh	Reactive Energy Consumption	R	NV	kVARh	0 - 3.4+E38	The UNITS property of object AI27 will report that these units are kWh because there is no unit type in the BACnet standard for kVARh.
AI28	kVA_A	Apparent Power Phase A	R		kVA	0 - Max_Power (AI45)	
AI29	kVA_B	Apparent Power Phase B	R		kVA	0 - Max_Power (AI45)	
AI30	kVA_C	Apparent Power Phase C	R		kVA	0 - Max_Power (AI45)	
AI31	KVAR_A	Reactive Power Phase A	R		kVAR	0 - Max_Power (AI45)	
AI32	KVAR_B	Reactive Power Phase B	R		kVAR	0 - Max_Power (AI45)	
AI33	KVAR_C	Reactive Power Phase C	R		kVAR	0 - Max_Power (AI45)	
AI34	KW_Present_Demand	Total Real Power Present Demand	R		kW	0 - Max_Power (AI45)	
AI35	KVAR_Present_Demand	Total Reactive Power Present Demand	R		kVAR	0 - Max_Power (AI45)	
AI36	KVA_Present_Demand	Total Apparent Power Present Demand	R		kVA	0 - Max_Power (AI45)	

#	Object_Name	Description	R/W	NV	Units	NA	Additional information
AI37	KW_Max_Demand	Total Real Power Maximum Demand	R	NV	kW	0 - Max_Power (AI45)	This retains the largest value measured for Total Real Power Demand (AI34) for any single demand interval since the Max Demand were last explicitly reset via AV1 (this is also reset when the demand interval is changed).
AI38	KVAR_Max_Demand	Total Reactive Power Maximum Demand	R	NV	KVAR	0 - Max_Power (AI45)	This retains the largest value measured for Total Reactive Power Demand (AI35) for any single demand interval since the Max Demand were last explicitly reset via AV1 (this is also reset when the demand interval is changed).
AI39	KVA_Max_Demand	Total Apparent Power Maximum Demand	R	NV	kVA	0 - Max_Power (AI45)	This retains the largest value measured for Total Apparent Power Demand (AI36) for any single demand interval since the Max Demand were last explicitly reset via AV1 (this is also reset when the demand interval is changed).
AI40	Pulse_Count_1	Pulse Count #1	R	NV	#	0 - 4294967040	Running count of contact closures on Pulse1 input since last reset. Write 16498 (0x4072) to the Present_Value property of Analog_Value object AV1 to reset both Pulse Counters to 0.
AI41	Pulse_Count_2	Pulse Count #2	R	NV	#	0 - 4294967040	Running count of contact closures on Pulse2 input since last reset. Write 16498 (0x4072) to the Present_Value property of Analog_Value object AV1 to reset both Pulse Counters to 0.
AI42	KWH_A	Real Energy Consumption Phase A	R	NV	kWh	0 - 3.4+E38	
AI43	KWH_B	Real Energy Consumption Phase B	R	NV	kWh	0 - 3.4+E38	
AI44	KWH_C	Real Energy Consumption Phase C	R	NV	kWh	0 - 3.4+E38	
AI45	Max_Power	Theoretical Maximum System Power	R	NV	kW	0 - 1.84467e19	Theoretical Maximum System Power – This is the theoretical maximum power the meter expects to see on a service. It is calculated by the meter from the System Type (in object AV2), CT Size (in object AV3), and System Voltage (in object AV6) - Power Factor is assumed to be unity. The register is updated whenever the user changes any of these parameters.
AI46	Reserved_AI46	Reserved	R			0	will return "0"
AI47	Energy Resets	Count of Energy Accumulator Resets	R	NV		0 - 32767	Running count of how many times the energy counter has been reset
AI48	Reserved_AI48	Reserved	R			0	will return "0"
AI49	Reserved_AI49	Reserved	R			0	will return "0"
AI50	Power Up Count	Power Up Counter	R	NV		0 - 32767	Running count of product power-up cycles (Control Power)
AI51	Ouput Config	Ouput Configuration	R	NV		0 - 15	EM3560 models will return "0"
AI52	Reserved_AI52	Alert Summary Register	R			0 - 32767	This contains a decimal value that represents the status of all 15 Binary_Object alert values in one number that can be read without having to access multiple objects. It is a decimal representation of a 15-bit hexadecimal value produced by combining the 15 alert bits into one number, where the bit value of Object BI1 is the least significant bit and BI15 is the most significant bit.

Binary_Input Objects

Use the Present_Value properties of the Binary_Input objects as alerts for conditions of potential concern regarding to the system measurement. These values are dynamic and are not latched, so if the condition is resolved, the alert will go inactive, whether it has been read or not.

These objects support the Description and Reliability object properties and all required Binary_Input object properties. None of them are writable. For complete assurance, check the Reliability property for a No_Fault_Detected status before reading the Present_Value.

To test the meter's alert status, read the Present_Value of each of the Binary_Objects representing the alert bits of interest, or read the Present_Value of AI52, which combines all 15 bits into a single decimal value. AI52 represents the status of all 15 Binary_Object alert values in one number that can be read without having to access multiple objects. The bit value of Object BI1 is the least significant bit and BI15 is the most significant bit.

#	Name	Description	R/W	Range	Additional information
BI1	Volts_Error_A	Voltage Out of Range Phase A	R	0=INACTIVE, 1=ACTIVE	Phase A Input Voltage exceeds meter's measurement range
BI2	Volts_Error_B	Voltage Out of Range Phase B	R	0=INACTIVE, 1=ACTIVE	Phase B Input Voltage exceeds meter's measurement range
BI3	Volts_Error_C	Voltage Out of Range Phase C	R	0=INACTIVE, 1=ACTIVE	Phase C Input Voltage exceeds meter's measurement range
BI4	Current_Error_A	Current Out of Range Phase A	R	0=INACTIVE, 1=ACTIVE	Phase A Current out of range
BI5	Current_Error_B	Current Out of Range Phase B	R	0=INACTIVE, 1=ACTIVE	Phase B Current out of range
BI6	Current_Error_C	Current Out of Range Phase C	R	0=INACTIVE, 1=ACTIVE	Phase C Current out of range
BI7	Frequency_Error	Frequency Error	R	0=INACTIVE, 1=ACTIVE	Phase A Frequency out of range
BI8	Reserved_BI8	Reserved	R	0=INACTIVE, 1=ACTIVE	will always return "INACTIVE"
BI9	Phase_Loss_A	Phase Loss Phase A	R	0=INACTIVE, 1=ACTIVE	Phase Loss - Phase A voltage dropped below the Phase Loss Threshold set by user
BI10	Phase_Loss_B	Phase Loss Phase B	R	0=INACTIVE, 1=ACTIVE	Phase Loss - Phase B voltage dropped below the Phase Loss Threshold set by user
BI11	Phase_Loss_C	Phase Loss Phase C	R	0=INACTIVE, 1=ACTIVE	Phase Loss - Phase C voltage dropped below the Phase Loss Threshold set by user
BI12	Power_Factor_A	Low Power Factor Phase A	R	0=INACTIVE, 1=ACTIVE	Phase A Power Factor less than 50% (commonly due to mis-wiring of CTs/PTs to meter)
BI13	Power_Factor_B	Low Power Factor Phase B	R	0=INACTIVE, 1=ACTIVE	Phase B Power Factor less than 50% (commonly due to mis-wiring of CTs/PTs to meter)
BI14	Power_Factor_C	Low Power Factor Phase C	R	0=INACTIVE, 1=ACTIVE	Phase C Power Factor less than 50% (commonly due to mis-wiring of CTs/PTs to meter)
BI15	RTC_Reset	RTC Reset	R	0=INACTIVE, 1=ACTIVE	Real-Time Clock reset. This goes active when Control Power is applied to the meter after an interruption (since it does not use a battery backup), and it stays active until a Time_Synchronization occurs. It indicates that the Real-Time clock has re-initialized to a default setting (00:00:00:00 on Jan 1, 2000) and should not be relied upon. The clock will be running; the meter will operate and even log data, but the date and time will not be correct until a Time_Synchronization occurs.

DATA LOGGING

The EM3560 includes a data logging feature that records three meter parameters, accessible via BACnet using Trend_Log objects. All three Trend_Log objects utilize shared data logging resources in the meter, so all three are controlled in unison. All writable properties other than Log_Device_Property_Object are common to all three Trend_Log objects. Changes to these properties (Log Enable, Start Time, Stop Time, Log Interval, Stop When Full or Record Count) for any one of the objects will be reflected in the corresponding property of all three objects. The Log_Interval property is also common with the Demand_Subinterval (Present_Value of AV11), since logging records are updated synchronously with demand calculations.

Default settings cause logging to begin immediately, with 15 minute intervals and no stop time. When full, the buffer will wrap and overwrite the oldest data first (unless the Stop When Full property is used).

Configuration

Use Log_Device_Object_Property to select the meter parameter to log with each object. Set this property to point to Present_Value property of any of the Analog_Input objects. The default the values for the Log_Device_Object_Property of the three Trend_Log objects are set as follows:

- TL1 = Real Energy Consumption (AI1 Present_Value)
- TL2 = Reactive Energy Consumption (AI27 Present_Value)
- TL3 = Total Real Power Present Demand (AI34 Present_Value)

The Log_Interval (& Demand Subinterval) can be set from 10 seconds to 32767 seconds (values of 1000 to 3276700). The subinterval timer, which determines how often the meter's demand accumulators are updated, also triggers writing to the Trend_Log log buffers. Use the Log_Interval property to set the data logging time subinterval, in units of hundredths of a second (0.01 seconds). The default subinterval is 15 minutes (a value of 90000 in the Log_Interval property). The Buffer_Length is fixed at 5760, so at a 15 minute interval setting, the buffers hold 60 days of data.

Use the Stop_When_Full property to select either Single Shot (Stop_When_Full = TRUE) or Continuous mode (Stop_When_Full = FALSE) for data logging. The default mode is Continuous. In Single Shot mode, the meter records data only until the buffer is full. Data for this time period is kept, but newer energy information is lost. In Continuous mode, the meter continues to record energy data as long as the meter is operating. The buffer can only hold 5760 entries at one time, however, so when the number of records exceeds 5760, the oldest entry is deleted to make room for the newest.

To start data logging with any of the three Trend_Log objects, set the Log_Enable property to TRUE or set the Start_Time and Stop_Time properties appropriately and wait for logging to commence at Start_Time.

By default, the Record_Count property of the Trend_Log objects is initialized to Zero.

Reading Data

Access logged data with corresponding timestamps via the Log_Buffer property of the Trend_Log object using the BACnet ReadRange service. The EM3560 supports both the "by Position" and "by Sequence Number" modes of the ReadRange service, but not the "by Time" mode.

Trend_Log

Trend_Log Properties Used	R/W	Units	Additional information
Object_Name	R	Trend_Log_<n>	Where n is 1-3 (there are three instances of Trend_Log objects available).
Description	R	Trend Log <n>	Where n is 1-3 (there are three instances of Trend_Log objects available).
Log_Enable	W	Binary	Set this to TRUE to enable logging or FALSE to disable logging. The default is TRUE. The value is set to FALSE internally if logging stops for other reasons (i.e. buffer is full).
Start_Time	W	Date/Time	Sets the Date/Time when data logging will Start (if Log_enable is TRUE). Set to a Date/Time earlier than the Local_Date/Local_Time properties of the Device object and Set Log_Enable TRUE to start logging immediately.
Stop_Time	W	Date/Time	Sets the Date/Time when data Logging will STOP (if still running). Stop_Time will be ignored if ""wildcard"" values are used in any of the fields.
Log_Device_Object_Property	W	BACnetDeviceObjectPropertyReference	Set (point) this to the Present_Value of any of objects AI1 through AI49 to establish which parameter to log. Default values are: TL1 = Real Energy Consumption (Array of AI1 Present_Value) TL2 = Reactive Energy Consumption (Array of AI27 Present_Value) TL3 = Total Real Power Present Demand (Array of AI34 Present_Value)
Log_Interval	W	0.01 seconds	Logging period in hundredths of a second. Default is 90000 (15 minute intervals); minimum value is 1000 (10 seconds). This property can also be set to Zero, which will change all three Trend_Logs and the Demand calculation to a manual mode (sometimes referred to as "Sync to Comms". In manual mode, the demand interval is updated and another record is logged upon a manual command, which is issued by writing the value 21211 to the Present_Value of object AV1.
Stop_When_Full	W	Binary	Set this to TRUE to stop logging when the buffer is full (single-shot mode) or FALSE to continue when full (wrap & overwrite oldest data entries).
Buffer_Size	R	5760	Length of Log Data buffer (# of records).
Log_Buffer	R	List of BACnetLongRecord	Contains the data values logged, with timestamps.
Record_Count	W	Unsigned 32-bit integer	This is an integer count of how many records logged since the Trend_Log objects were last reset. Writing a Zero to this property resets the logs of all three objects. This value defaults to Zero, but, by default, logging will start automatically at 15 minute intervals.
Total_Record_Count	R	Unsigned 32-bit integer	This is an integer count of how many records logged since the Trend_Log objects were created (the factory state of the meter). This count is unaffected by resetting the Record Count or by power failures.
Event_State	R	Binary	

TROUBLESHOOTING

Problem	Cause	Solution
The maintenance wrench icon appears in the power meter display.	There is a problem with the inputs to the power meter.	See the Alert sub-menu or the Diagnostic Alert BACnet Binary_Input objects.
The display is blank after applying control power to the meter.	The meter is not receiving adequate power.	Verify that the meter control power is receiving the required voltage. Verify that the heart icon is blinking. Check the fuse.
The data displayed is inaccurate.	Incorrect setup values	Verify the values entered for power meter setup parameters (CT and PT ratings, system type, etc., see Setup section).
	Incorrect voltage inputs	Check power meter voltage input terminals to verify adequate voltage.
	Power meter is wired improperly.	Check all CTs and PTs to verify correct connection to the same service, PT polarity, and adequate powering (see Wiring Diagrams section).
Cannot communicate with power meter from a remote personal computer.	Power meter address is incorrect.	Verify that the meter is correctly addressed (see Setup section).
	Power meter baud rate is incorrect.	Verify that the baud rate of the meter matches that of all other devices on its communications link (see Setup section).
	Communications lines are improperly connected.	Verify the power meter communications connections (see Communications section). Verify the terminating resistors are properly installed on both ends of a chain of units. Units in the middle of a chain should not have a terminator. Verify the shield ground is connected between all units.

CHINA ROHS COMPLIANCE INFORMATION (EFUP TABLE)

部件名称	产品中有毒有害物质或元素的名称及含量Substances					
	铅 (Pb)	汞 (Hg)	镉 (Cd)	六价铬 (Cr(VI))	多溴联苯 (PBB)	多溴二苯醚 (PBDE)
电子线路板	X	0	0	0	0	0
0 = 表示该有毒有害物质在该部件所有均质材料中的含量均在 SJ/T11363-2006 标准规定的限量要求以下。 X = 表示该有毒有害物质至少在该部件的某一均质材料中的含量超出SJ/T11363-2006标准规定的限量要求。						
Z000057-0A						

EM3560
Installation Guide

Schneider Electric
295 Tech Park Dr. Suite 100
La Vergne TN, 37086

For technical support:
Global-PMC-Tech-support@schneider-electric.com
(00) + 1 250 544 3010

Contact your local Schneider Electric sales
representative for assistance or go to
www.schneider-electric.com

ION, Modbus, and PowerLogic are either trademarks or registered trademarks of Schneider Electric in France, the USA and other countries. Other trademarks used are the property of their respective owners.

Electrical equipment should be installed, operated, serviced, and maintained only by qualified personnel. No responsibility is assumed by Schneider Electric for any consequences arising out of the use of this material.

ZL0094-0A 11/2011

© 2011 Schneider Electric. All Rights Reserved.