

PowerLogic® High Density Metering System 1-Meter Enclosure Installation Guide

Retain for future use.

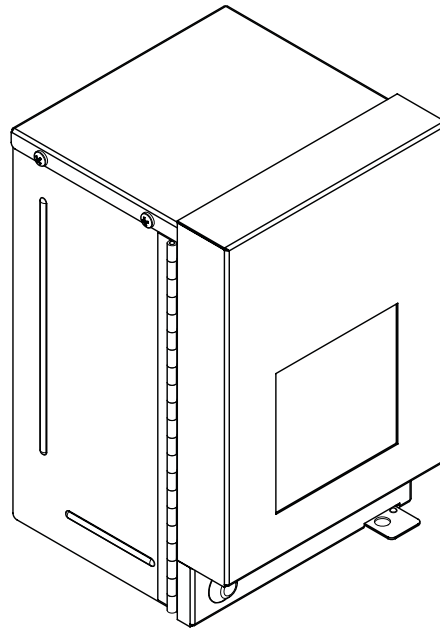

HAZARD CATEGORIES AND SPECIAL SYMBOLS

Read these instructions carefully and look at the equipment to become familiar with the device before trying to install, operate, service or maintain it. The following special messages may appear throughout this bulletin or on the equipment to warn of potential hazards or to call attention to information that clarifies or simplifies a procedure.



The addition of either symbol to a “Danger” or “Warning” safety label indicates that an electrical hazard exists which will result in personal injury if the instructions are not followed.



This is the safety alert symbol. It is used to alert you to potential personal injury hazards. Obey all safety messages that follow this symbol to avoid possible injury or death.

DANGER

DANGER indicates an imminently hazardous situation which, if not avoided, **will result in** death or serious injury.

WARNING

WARNING indicates a potentially hazardous situation which, if not avoided, **can result in** death or serious injury.

CAUTION

CAUTION indicates a potentially hazardous situation which, if not avoided, **can result in** minor or moderate injury.

CAUTION

CAUTION, used without the safety alert symbol, indicates a potentially hazardous situation which, if not avoided, **can result in** property damage.

NOTE: Provides additional information to clarify or simplify a procedure.

PLEASE NOTE

Electrical equipment should be installed, operated, serviced, and maintained only by qualified personnel. No responsibility is assumed by Schneider Electric for any consequences arising out of the use of this material.

SECTION 1: 1-METER ENCLOSURE

Introduction 1
1-Meter Cabinet 1
Parts and Accessories 3
Box Contents 3
Topics Not Covered 3
Safety Precautions 4
Specifications 4
Mounting the Enclosure 5
Mounting Dimensions 6
Wiring Connections 8
Shorting Block Use 9
Current Transformers 10
Wiring Diagrams 10
Control Power 12
Communications 13
Initializing the Meters 14
Cover Plates 14

APPENDIX A: METER WIRING DIAGRAMS

Safety Precautions 15
PM210 without CPT 16
PM210 with CPT 17
PM750 without CPT 18
PM750 with CPT 19
ION6200 without CPT 20
ION6200 with CPT 21

SECTION 1— 1-METER ENCLOSURE

INTRODUCTION

The PowerLogic® High Density Metering System is used to monitor the amount of electricity used in individual units of multi-unit residential or commercial buildings. The system consists of one or more power meters housed in a wall-mounted metal cabinet or enclosure. Multiple enclosures may be installed at a single location.

A meter is assigned to a tenant who occupies an individual unit within a complex. The meter monitors and records the energy consumed inside the unit. At pre-determined times, tenant billing software polls the meter through a communications link to gather usage information. This information can be used as a means of monitoring overall electrical usage or to generate an electric bill for the tenant.

NOTE: Some states do not permit sub-billing. Before billing tenants, check your state and local regulations.

1-Meter Cabinet

The 1-Meter cabinet is available in two configurations (see Figure 1–1). The Type 1 configuration has a clear, viewing window in the door but does not have a rain hood. The Type 3R configuration has a rain hood and a solid door (no viewing window).

The UL description for Type 1 and Type 3R are as follows:

- Type 1—Indoor use primarily to provide a degree of protection against limited amounts of falling dirt.
- Type 3R—Outdoor use primarily to provide a degree of protection against rain, sleet, and damage from external ice formation.

The door is equipped with a hasp for a lock or seal.

Figure 1–1: 1-Meter Enclosure

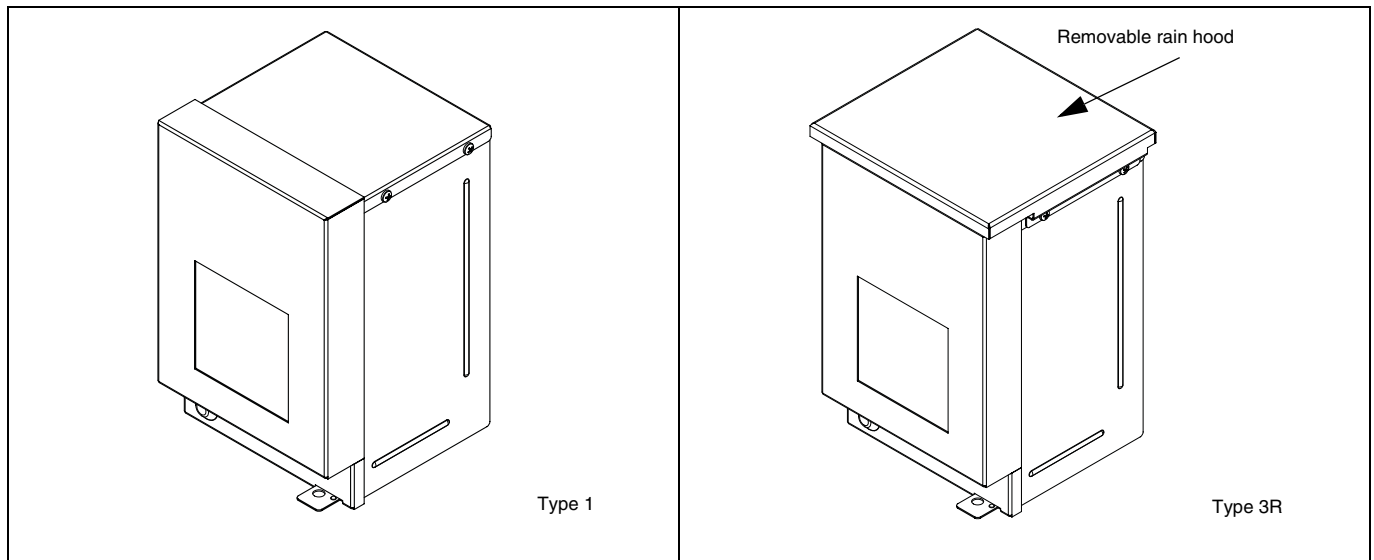

The meter, interior components, and wiring connections are covered by a protective, removable, exterior case. To access the interior, remove the case from the supporting base/backplate (see Figure 1–2). The meter is positioned on a supporting bracket attached to the base/backplate that swivels outward to allow access to the back of the meter and terminals for field wiring.

To remove the case, complete these steps:

1. Open the door.
2. Remove the front bonding screw.
3. Lift the case up and out to slide off the base/backplate.

To re-install the case, reverse the steps .

Figure 1–2: Case removal

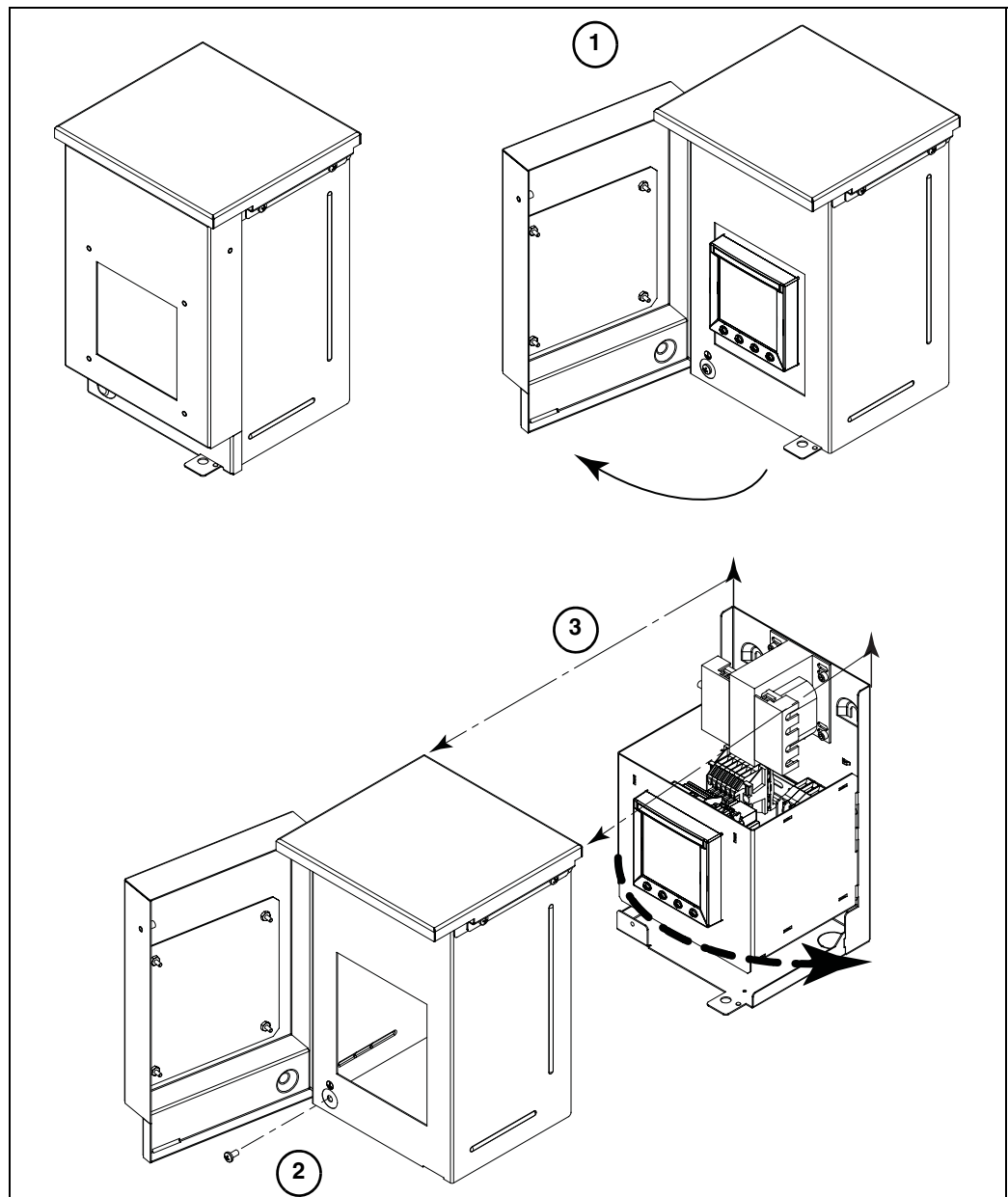

The bracket has a small locking feature to hold open in the 90° position. The bracket can be swiveled out by lifting up slightly and out from the left side.

Parts and Accessories

The 1-Meter Cabinet can house any of the following PowerLogic meters:

- PM210
- PM750
- ION6200

The enclosure is shipped with a meter already installed and wired. Table 1–1 lists part numbers and accessories for the High Density Metering System—1-Meter Cabinet.

Table 1–1: Parts and Accessories

Description	Part Number
PowerLogic Power Meter	See Power Meter installation document (PM210, PM750, ION6200).
Cover Plate Assembly Kit	96DINCVRPLT

Box Contents

The following components are shipped with the 1-Meter Cabinet:

- Enclosure containing pre-installed meter, shorting block, and wiring harness
- Shorting screws (already mounted)
- MCT2W terminating resistor
- Cover plate assembly kit (when meter is supplied)
- Installation bulletin for meter
- This installation guide

Topics Not Covered

Meter documentation is shipped with the enclosure. For more information on your particular meter, see the meter installation bulletin (also available in the technical library at www.powerlogic.com).

PowerLogic® Tenant Metering Software is purchased separately and includes installation and use instructions.

SAFETY PRECAUTIONS

This section contains important safety precautions that must be followed before attempting to install, service, or maintain electrical equipment. Carefully read and follow the safety precautions outlined below.

⚠ DANGER	
HAZARD OF ELECTRIC SHOCK, EXPLOSION, OR ARC FLASH	
<ul style="list-style-type: none"> • Apply appropriate personal protective equipment (PPE) and follow safe electrical work practices. See NFPA 70E. • This equipment must be installed and serviced only by qualified electrical personnel. • Turn off all power supplying this equipment before working on or inside equipment. • Always use a properly rated voltage sensing device to confirm that power is off. • Replace all devices, doors, and covers before turning on power to this equipment. 	
Failure to follow this instruction will result in death or serious injury.	

SPECIFICATIONS

Table 1–2: Technical specifications

PHYSICAL CHARACTERISTICS	
Dimensions	
Without hood	W 7.42 inches, H 11.32 inches, D 7.37 inches [W 189 mm, H 287.74 mm, D 187.86 mm]
With hood	W 7.88 inches, H 11.92 inches, D 7.50 inches [200.03 mm, H 302.84 mm, D 190.47 mm]
Mounting	Wall mount
Weight (maximum including meter, hood, and CPT)	15.5 lbs./7kg.
COMMUNICATIONS	
RS485 port	2-wire, up to 19200 baud, Modbus RTU
POWER	
Power specifications vary according to equipment configuration. See separate power specifications in Table 1–3.	
ENVIRONMENTAL CHARACTERISTICS	
Operating temperature	
PM210, PM750	-10° C to +55° C
ION6200	-20° C to +70° C
Storage temperature	-40° C to +85° C
Humidity rating	5 to 95% RH at 50° C (non-condensing)
Pollution degree	2
Altitude	3000 m
STANDARDS	
US and Canada	
Enclosure	UL 50; UL 508A
Meter Accuracy Rating	
PM210	ANSI C12.16 Accuracy Class 1
PM750	ANSI C12.20 Accuracy Class 0.5
ION6200	ANSI C12.20 Accuracy Class 0.5

Table 1–3: Power specifications

Meter	Specification
Without CPT	
PM210	115 to 415 ± 10% Vac, 5 VA; 50 to 60 Hz or 125 to 250 ± 20% Vdc, 3W
PM750	115 to 415 ± 10% Vac, 5 VA; 50 to 60 Hz or 125 to 250 ± 20% Vdc, 3W
ION6200	100 to 240 Vac, 13 VA; 50 to 60 Hz or 110 to 300 Vdc, 3W
With CPT	
PM210	400 to 480 Vac, 5 VA; 50 to 60 Hz
PM750	400 to 480 Vac, 5 VA; 50 to 60 Hz
ION6200	400 to 480 Vac, 13 VA; 50 to 60 Hz
CT inputs	
CT inputs	5 A nominal, 6 A maximum
Voltage Inputs	
PM210/PM750	
	10 to 480 Vac (L-L)
	10 to 277 Vac (L-N)
	10 to 1.6 MVac with external VT
ION6200	
	103 to 690 Vac (L-L)
	60 to 400 Vac (L-N)

MOUNTING THE ENCLOSURE

Mount the metering cabinet next to the distribution panelboard that serves the load to be monitored.

Four (4) pre-drilled 3/8-inch holes are provided on the backplane of the enclosure for mounting. Use #10 or up to 5/16-inch screws, with washers as needed, to attach the enclosure to the wall. Always mount with four (4) screws. Figure 1–3 shows the pre-drilled mounting holes and knockout points for the electrical conduit.

Figure 1–3: Mounting holes and conduit knockouts

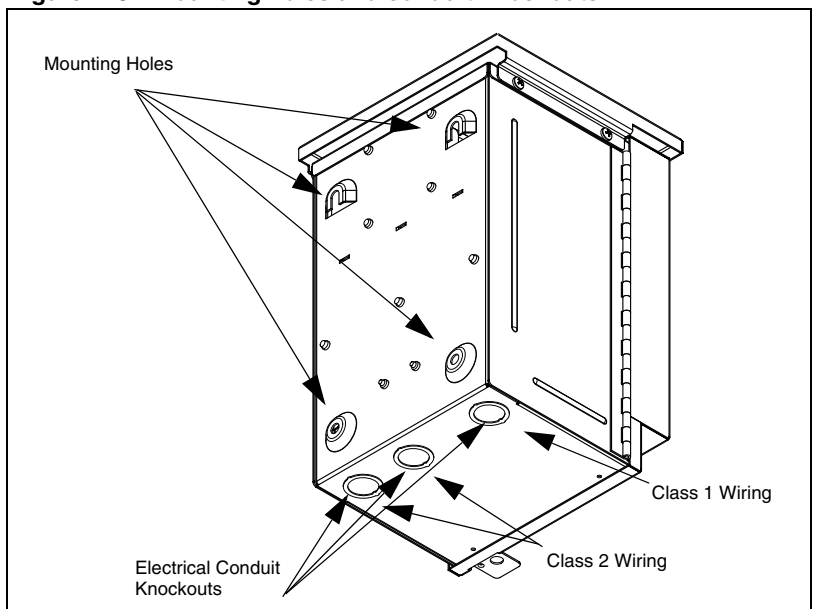

CAUTION

EQUIPMENT DAMAGE HAZARD

- Do not drill into the enclosure. Drilling will produce metal shavings that may fall into vents, reduce spacings, and possibly create electrical short circuits.

Failure to follow this instruction can result in equipment damage.

Mounting Dimensions

Figure 1–5 shows dimensions for the enclosure with the hood.
Measurements shown are in [millimeters] and inches.

Figure 1–4: Dimensions for enclosure without hood

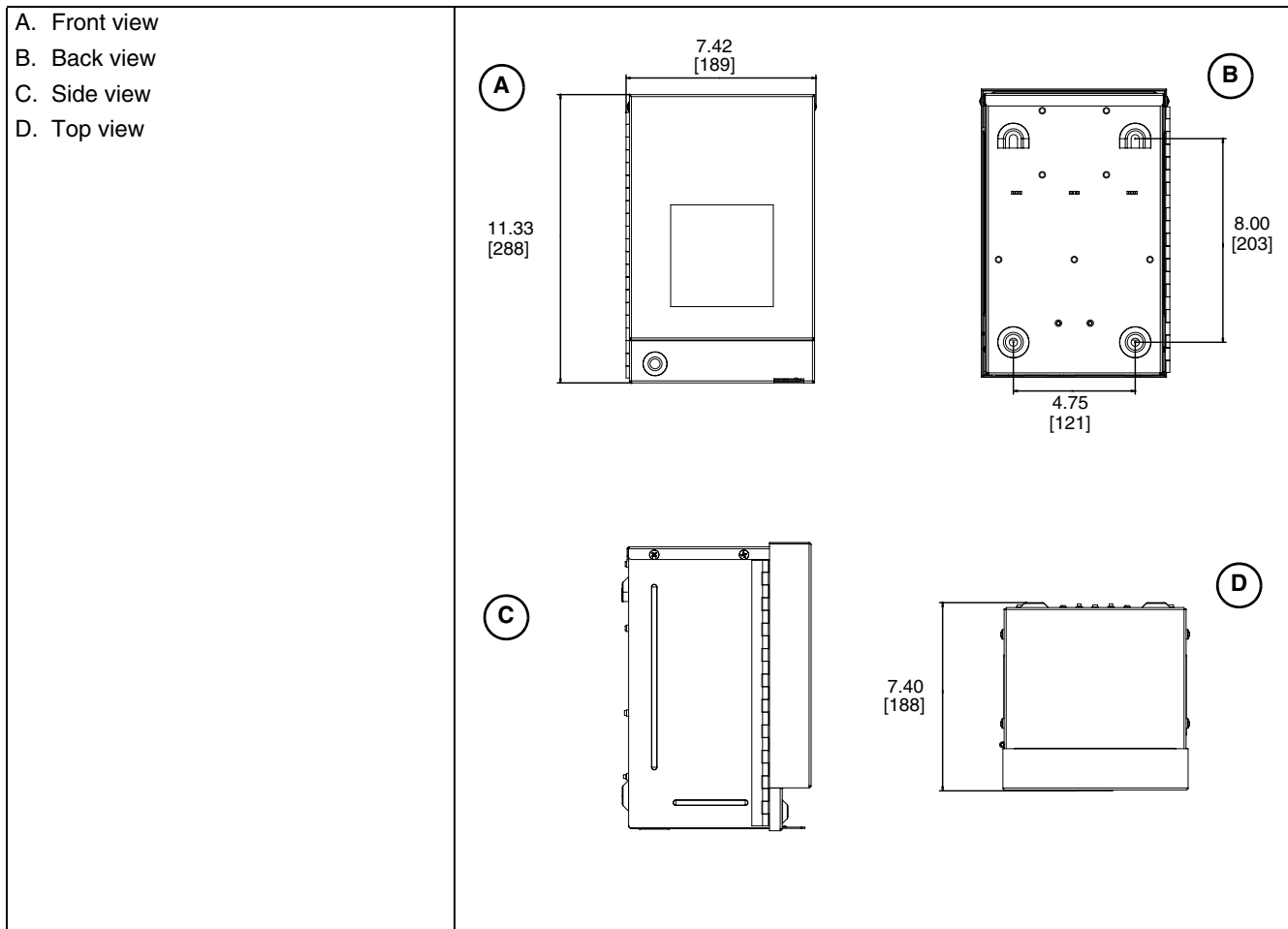
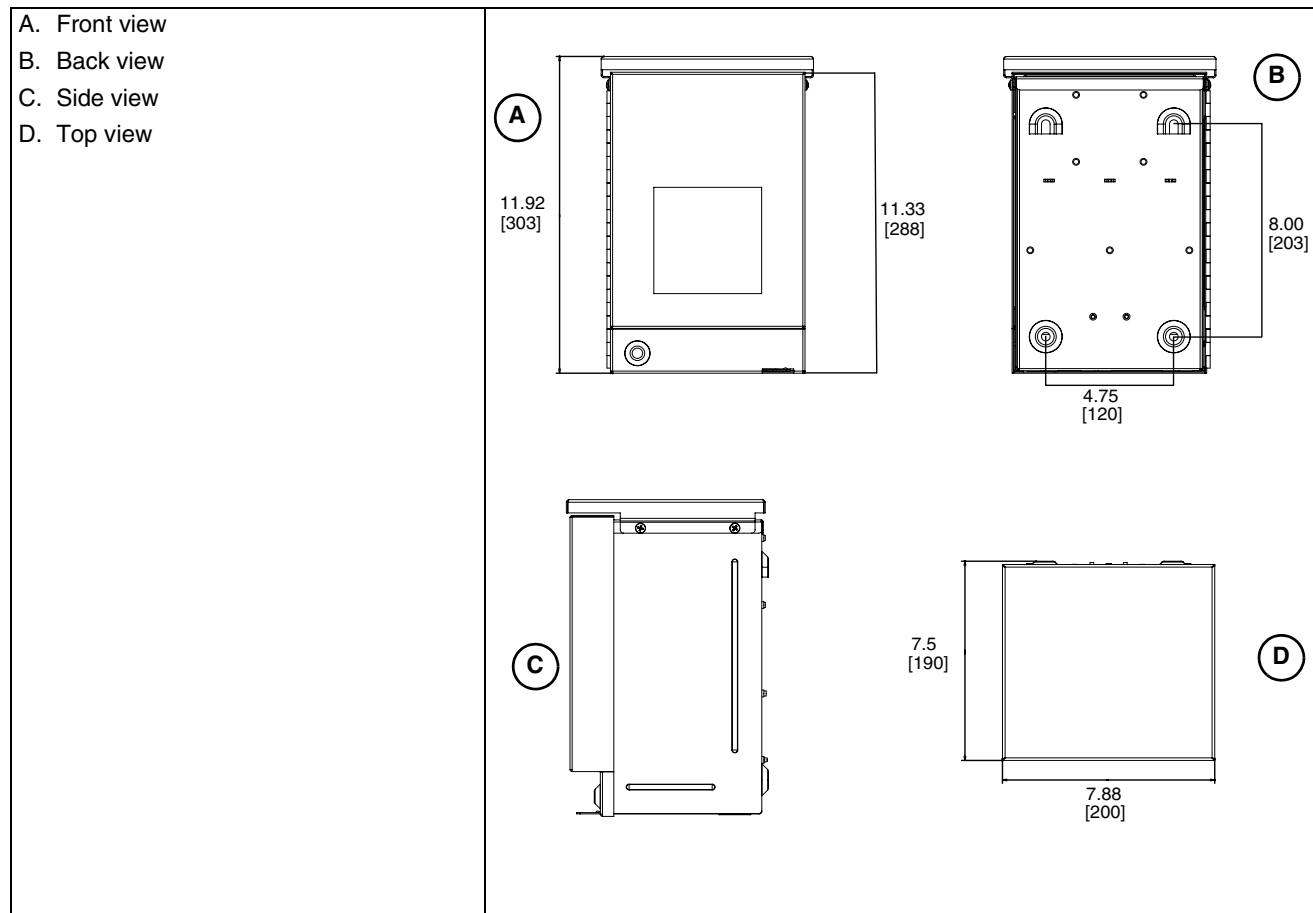

Figure 1-5: Dimensions for enclosure with hood



WIRING CONNECTIONS

Conduit knockouts are provided on the enclosure (see Figure 1–3 on page 5). To comply with national and local standards, Class 1 (voltage input) wiring must be kept separate from Class 2 (current transformer and communications) wiring. Refer to NEC code and local codes before installing.

NOTE: Control power and voltage inputs require overcurrent protection external to the cabinet.

NOTE: Conduit hubs shall be rated to the same weather rating as the enclosure and must comply with the standard for Conduit, Tubing and Cable Fittings, UL 514B.

NOTE: Voltage inputs shall be connected to the load side of a Class CC, G, J, RK1, RK5, L or T 7A branch circuit fuse or inverse-time/instantaneous-trip circuit breaker. Use copper conductors only.

NOTE: The wiring configuration is designed specifically for the High Density Metering System application. Do not change the wiring configuration.

DANGER

HAZARD OF ELECTRIC SHOCK, EXPLOSION, OR ARC FLASH

- Turn off all power supplying this equipment before working on or inside equipment.
- Use a properly rated voltage sensing device to confirm that all power is off.
- Replace all devices, covers, and close all doors before turning on power to this equipment.
- Before energizing enclosure, all unused spaces must be filled with blank covers.
- Use only established wiring configuration designed for the High Density Metering System.

Failure to follow this instruction will result in death or serious injury.

Shorting Block Use

See Figure 1-6 and follow the instructions below for using the shorting block.

Figure 1-6: Shorting Block Use

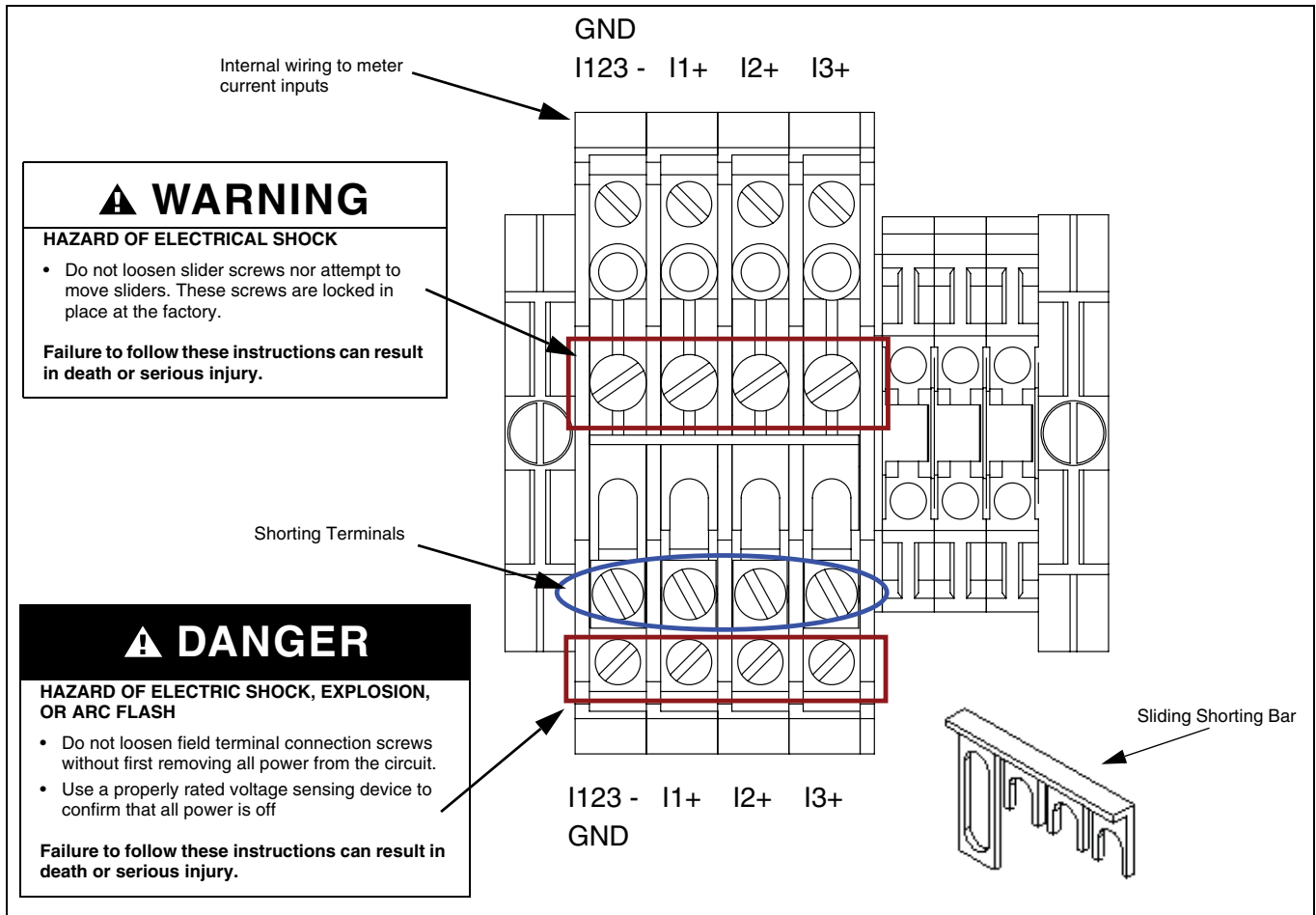

Shorting Terminals (default)

To short the terminals, complete these steps:

1. Turn off all power supplying this equipment before working on or inside this equipment. Use a properly rated voltage sensing device to confirm that all power is off.
2. Loosen the four (4) shorting bar screws.
3. Slide shorting bar toward field terminals or bottom of the enclosure.
4. Tighten all four (4) shorting bar screws (6 ± 1 in. lbs.).

Removing Short from Terminals (operational)

To remove short from terminals, complete these steps:

1. Turn off all power supplying this equipment before working on or inside this equipment. Use a properly rated voltage sensing device to confirm that all power is off.
2. Loosen all four (4) shorting bar screws.
3. Slide shorting bar away from field terminals or toward the top of the enclosure.
4. Tighten the left-most (GND) shorting bar screw.

Current Transformers

Field-installed current transformer (CT) leads require stripped wire terminal connections. The CT shorting block is shipped in the shorted position by default from the factory.

⚠ DANGER

HAZARD OF ELECTRIC SHOCK, EXPLOSION, OR ARC FLASH







- Never open circuit a CT; use the shorting block to short circuit the leads of the CT before attaching or removing any meter.

Failure to follow this instruction will result in death or serious injury.

Wiring Diagrams

The wiring diagrams in this manual use the symbols shown in Table 1–4.

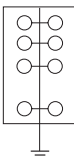
Table 1–4: Wiring Diagram Symbols

Symbol	Description
	Voltage disconnect switch
	Fuse
	Earth Ground
	Protective conductor terminal symbol
	Current transformer
	Shorting block
	Potential transformer
	US equivalent: 

NOTE: The disconnect circuit breaker must be placed within reach of the power meter and labeled: **Disconnect Circuit Breaker for Power Meter.**

Figure 1-7: 1-Phase 2-Wire System Line-to-Neutral 1CT

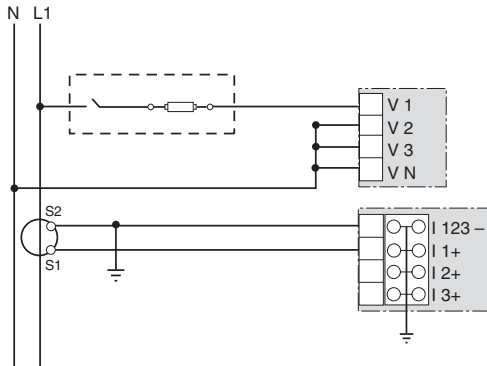

- For PM210 and PM750, use System type 10.
- For ION6200, use Volts Mode 2W.
- To avoid distortion, use parallel wires for control power and voltage inputs. Keep the fuse close to the power source.

Figure 1-8: 1-Phase 2-Wire System Line-to-Line 1CT

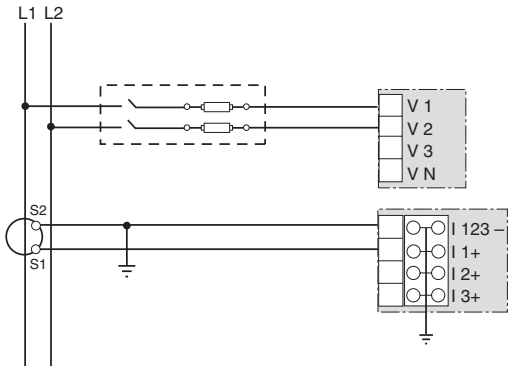

- For PM210 and PM750, use System type 11.
- For ION6200, use Volts Mode 2W.
- To avoid distortion, use parallel wires for control power and voltage inputs. Keep the fuse close to the power source.
- Use with 120/240 V systems.

Figure 1-9: 1-Phase Direct Voltage Connection 2 CT

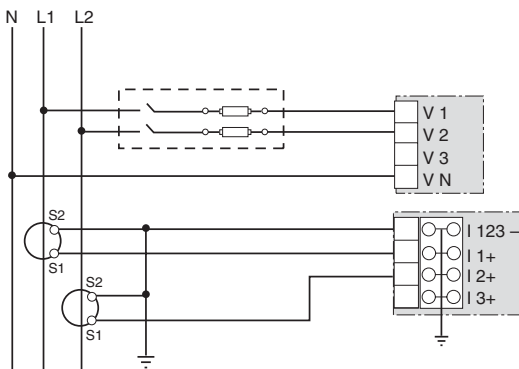

- For PM210 and PM750, use System type 12.
- For ION6200, use Volts Mode 2W.
- To avoid distortion, use parallel wires for control power and voltage inputs. Keep the fuse close to the power source.

Figure 1-10: 3-Phase 3-Wire 2 CT no PT

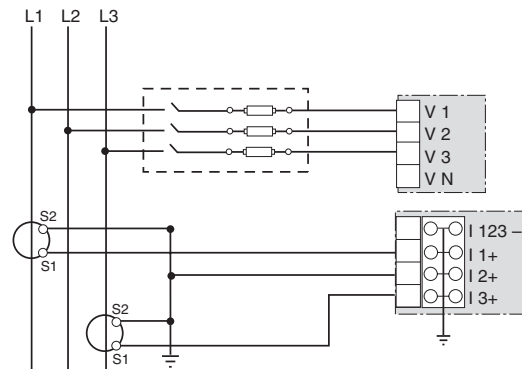

- For PM210 and PM750, use System type 30.
- For ION6200, use Volts Mode Delta Direct.

Figure 1-11: 3-Phase 3-Wire 3 CT no PT

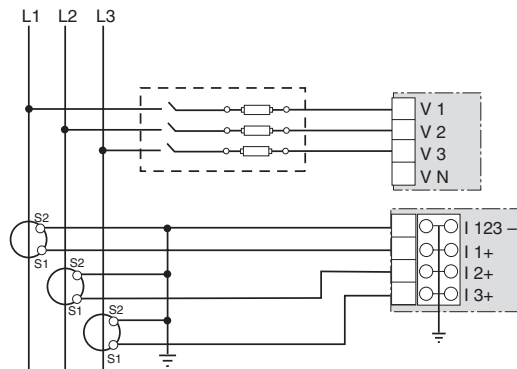

- For PM210 and PM750, use System type 31.
- For ION6200, use Volts Mode Delta Direct.

Figure 1-12: 3-Phase 4-Wire Wye Direct Voltage Input Connection 3 CT

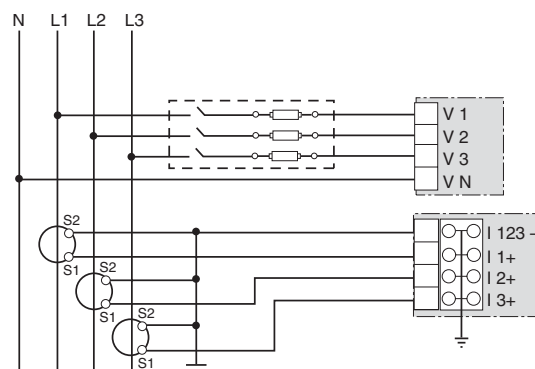

- For PM210 and PM750, use System type 40.
- For ION6200, use Volts Mode 4W-Wye.
- Use with 480Y/277 V and 208Y/120 V systems.

Control Power

Control power wiring depends on the installed meter. For the PM210 and PM750, see Figure 1–13 and Figure 1–14. For the ION6200, see Figure 1–15 and Figure 1–16.

Power Meters PM210 and PM750

Figure 1–13: Direct Connect Control Power (Phase to Phase) < 415 + 10% Vac

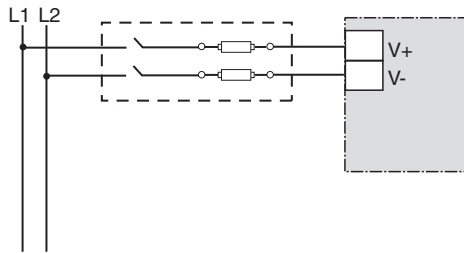
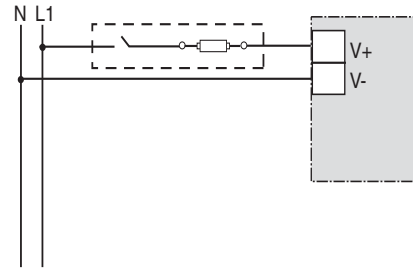

Figure 1–14: Direct Connect Control Power (Phase to Neutral) < 300 + 10% Vac



- Control power source > 415 Vac (L-L) or > 300 Vac (L-N) require a control power transformer. A control power transformer is available in this enclosure by specifying an input voltage range of "4T," which allows control power connections up to 480 Vac.

ION6200 Meter

Figure 1–15: Direct Connect Control Power (Phase to Phase) < 240 + 10% Vac

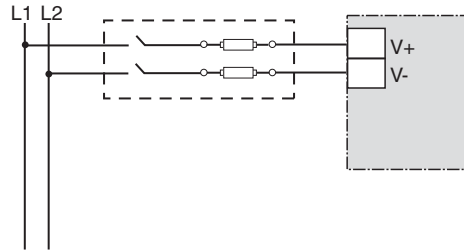
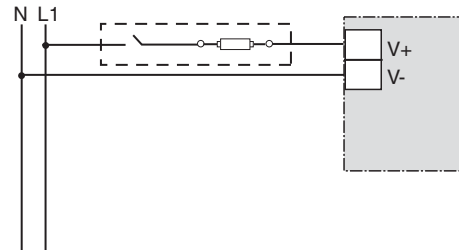

Figure 1–16: Direct Connect Control Power (Phase to Neutral) < 240 + 10% Vac



- Control power source > 240 Vac requires a control power transformer. A control power transformer is available in this enclosure by specifying an input voltage range of "4T," which allows control power connections up to 480 Vac.

Using jumpers, control power can be derived from the phase conductors. Control power can also be supplied by a separate feed.

Communications

The meters use common daisy-chain wiring and communicate using Modbus protocol over RS485. The last meter in the chain must be terminated. Figure 1-17 shows the communications connections.

Figure 1-17: RS485 Serial Modbus connection

- Last panel on daisy chain must be terminated. Use the MCT2W terminating resistor, included with enclosure.

NOTE: Torque all screws to 10± 1 in.-lbs.

NOTE: Multiple enclosures can be daisy-chained together. The maximum number of meters on a daisy-chain is 32. See the separate meter instruction bulletin for more information on communications connections.

NOTE: Terminator should be removed when connecting additional enclosures.

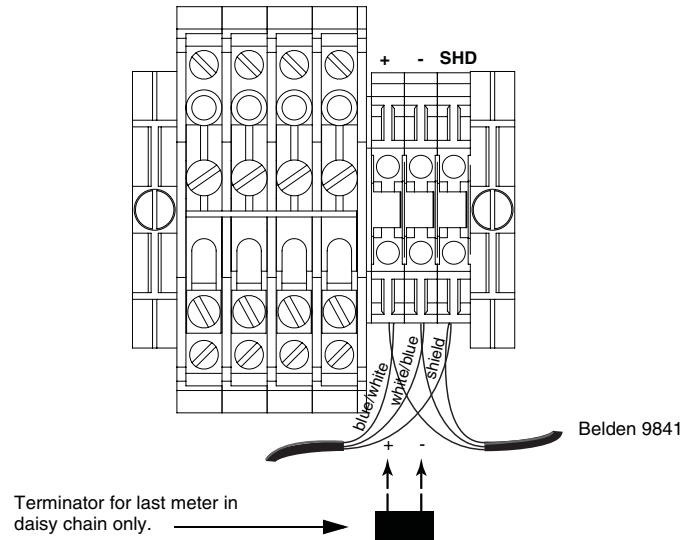

INITIALIZING THE METERS

The meter must be initialized before placing into service. For instructions on initializing the meters, see the meter instruction bulletin shipped with the cabinet (also available at www.powerlogic.com).

COVER PLATES

Cover plates are used to cover openings when no meter is present. Any time a meter is removed from the enclosure, a cover plate must be attached unless another meter is inserted into the slot. Figure 1–18 shows the cover plate assembly.

Figure 1–18: Cover plate

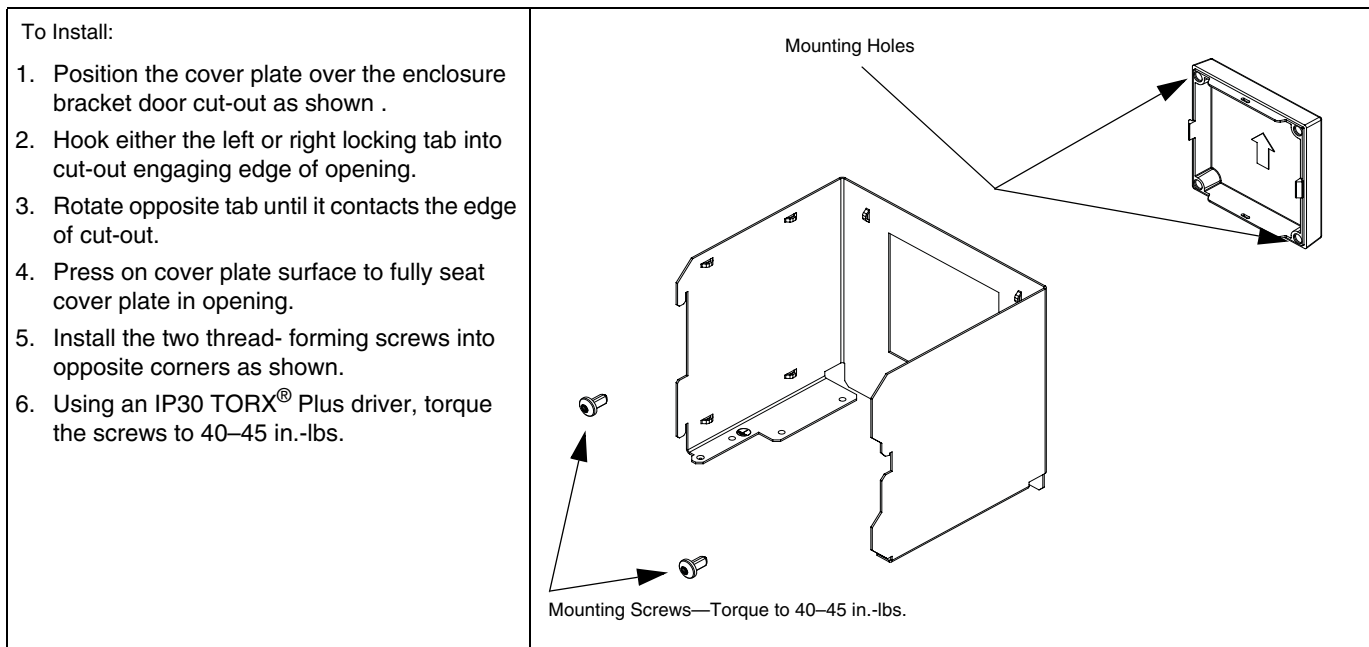

APPENDIX A—METER WIRING DIAGRAMS

Factory wiring diagrams for supported meters are shown in this appendix.

See meters on the following pages:

- PM210 without CPT on page 16
- PM210 with CPT on page 17
- PM750 without CPT on page 18
- PM750 with CPT on page 19
- ION6200 without CPT on page 20
- ION6200 with CPT on page 21

SAFETY PRECAUTIONS

⚠ DANGER
HAZARD OF ELECTRIC SHOCK, EXPLOSION, OR ARC FLASH
<ul style="list-style-type: none">• Turn off all power supplying this equipment before working on or inside equipment.• Use a properly rated voltage sensing device to confirm that all power is off.• Replace all devices, covers, and close all doors before turning on power to this equipment.• Before energizing enclosure, all unused spaces must be filled with blank covers.• Use only established wiring configuration designed for the High Density Metering System.
Failure to follow this instruction will result in death or serious injury.

PM210 WITHOUT CPT

TOP

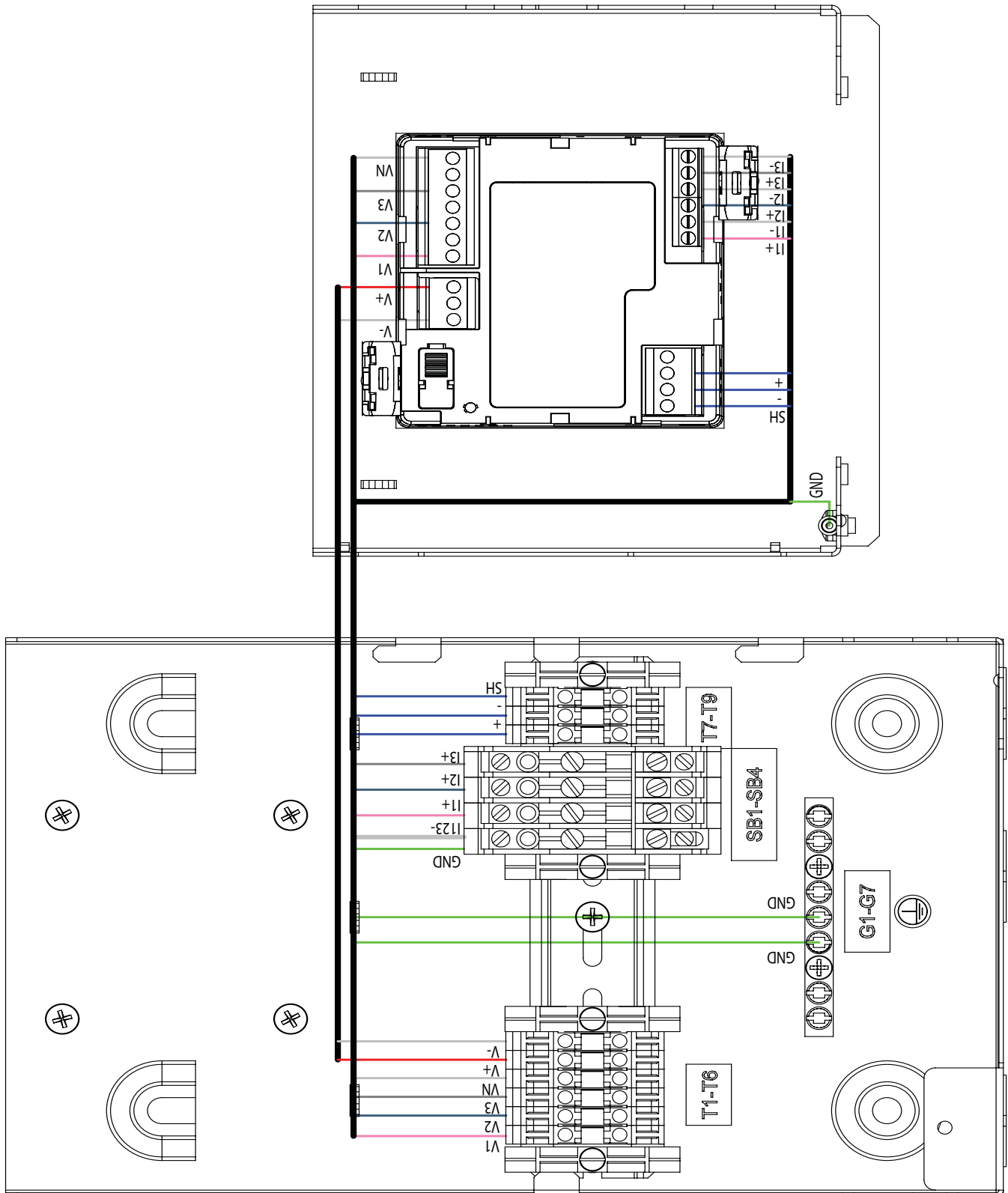

PM210 WITH CPT

TOP

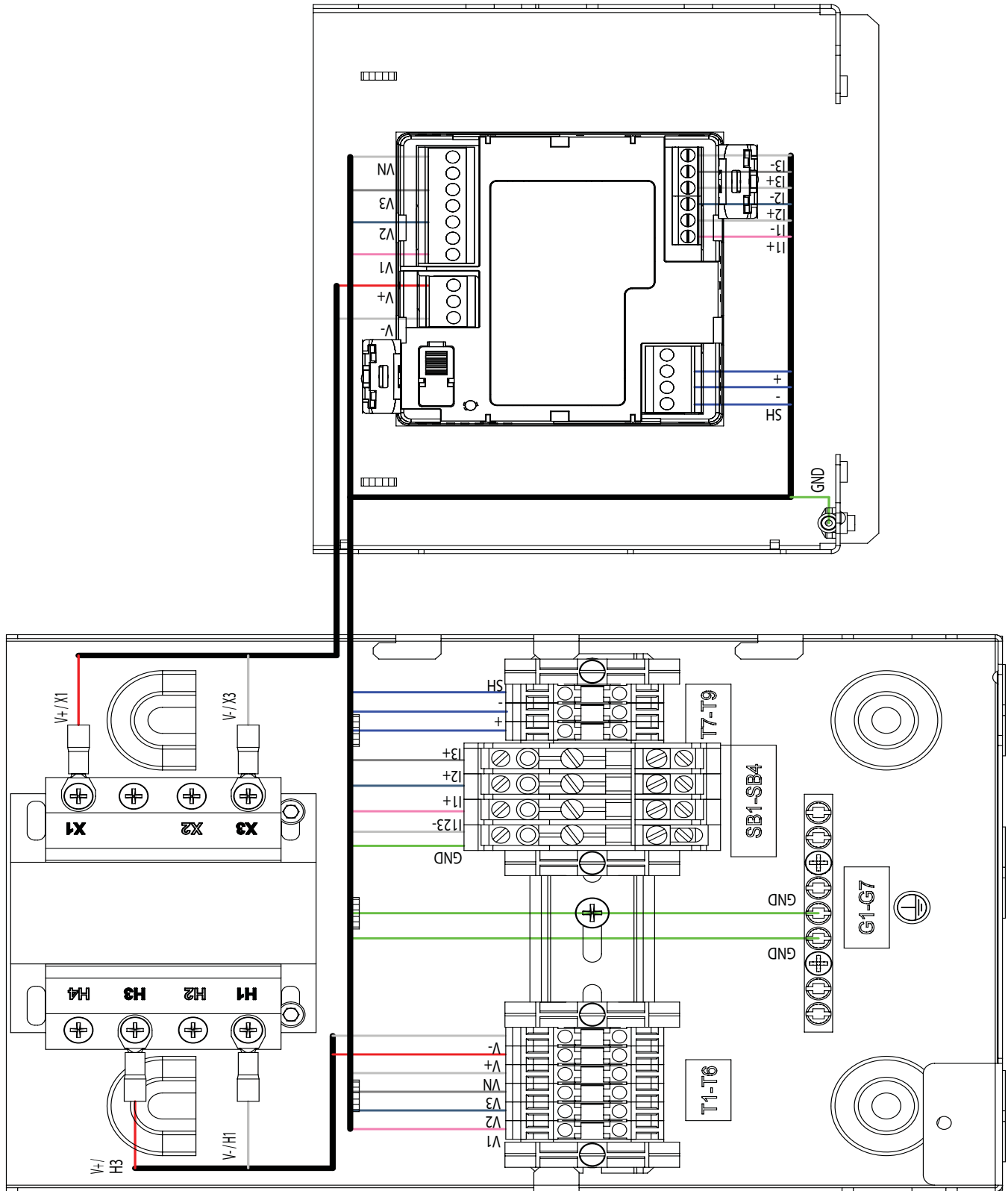

PM750 WITHOUT CPT

TOP

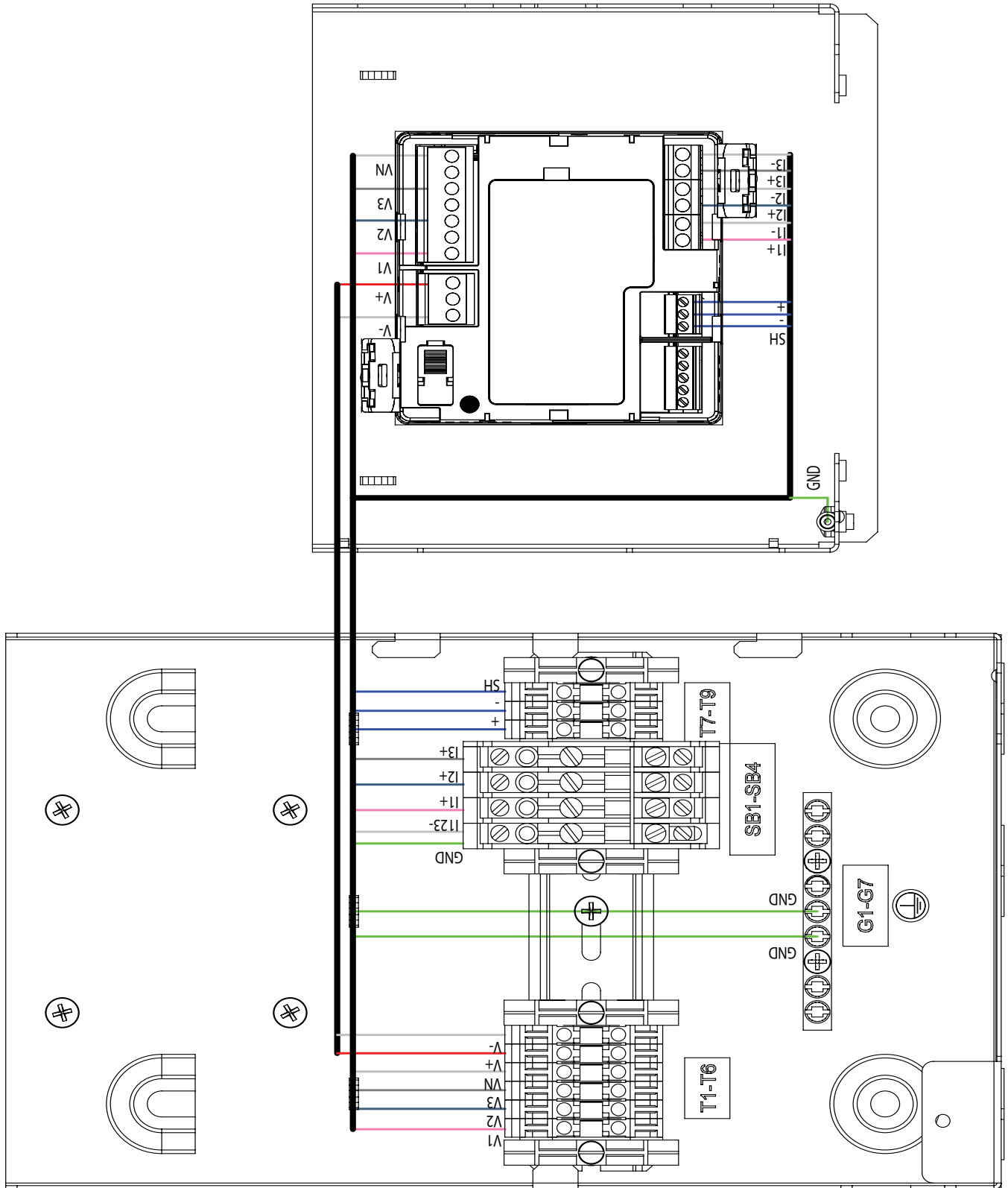

PM750 WITH CPT

TOP

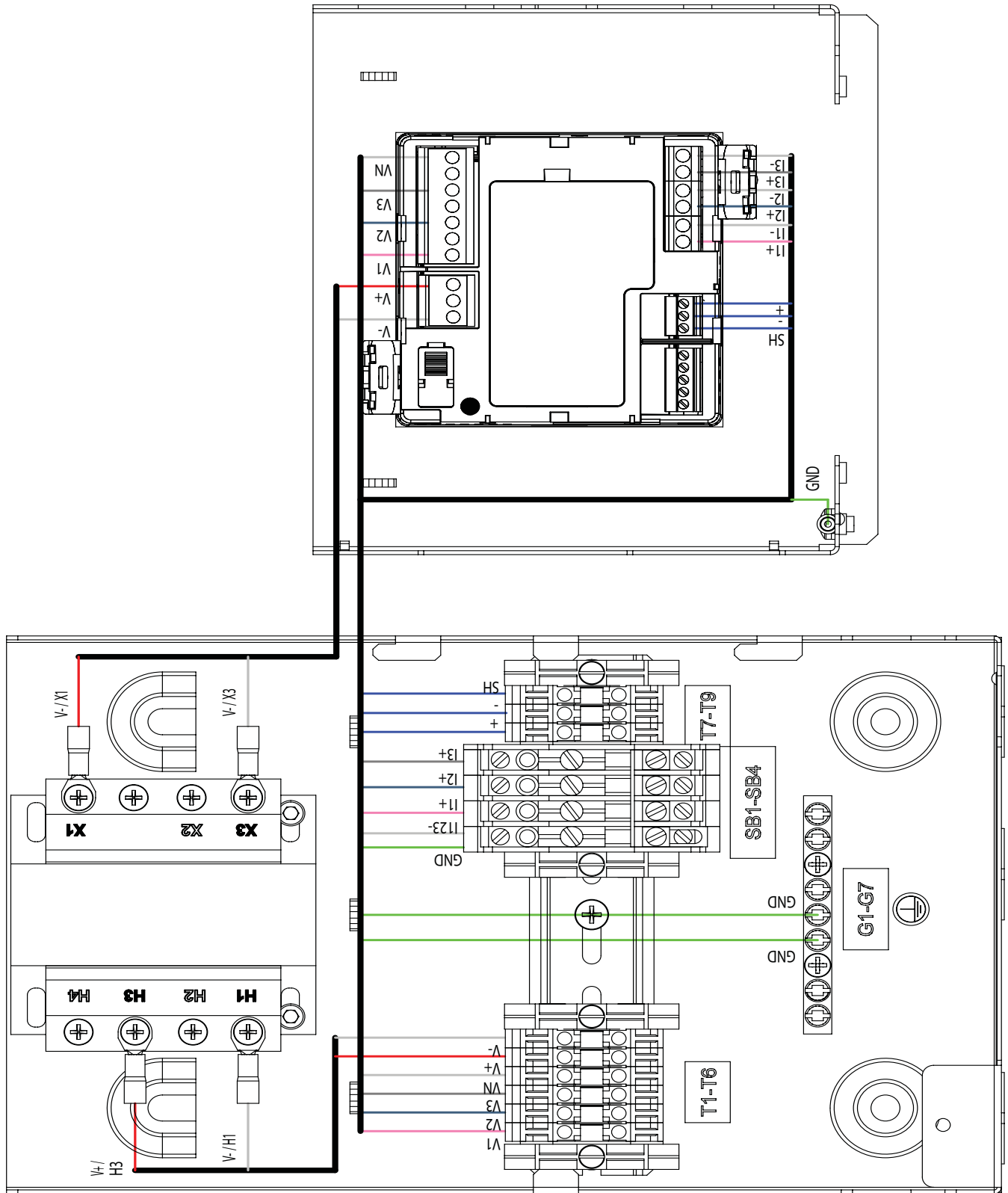

ION6200 WITHOUT CPT

TOP

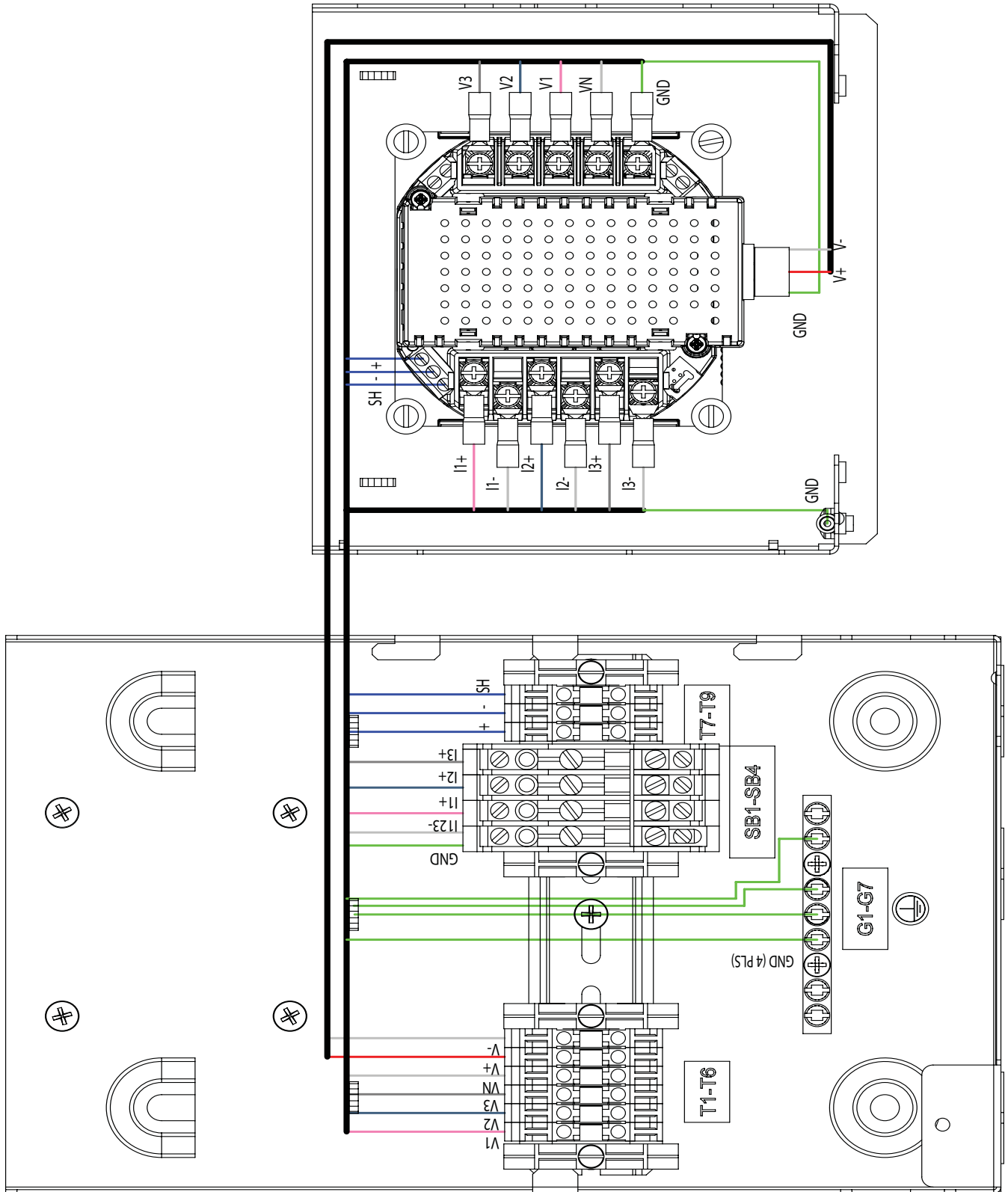

ION6200 WITH CPT

TOP

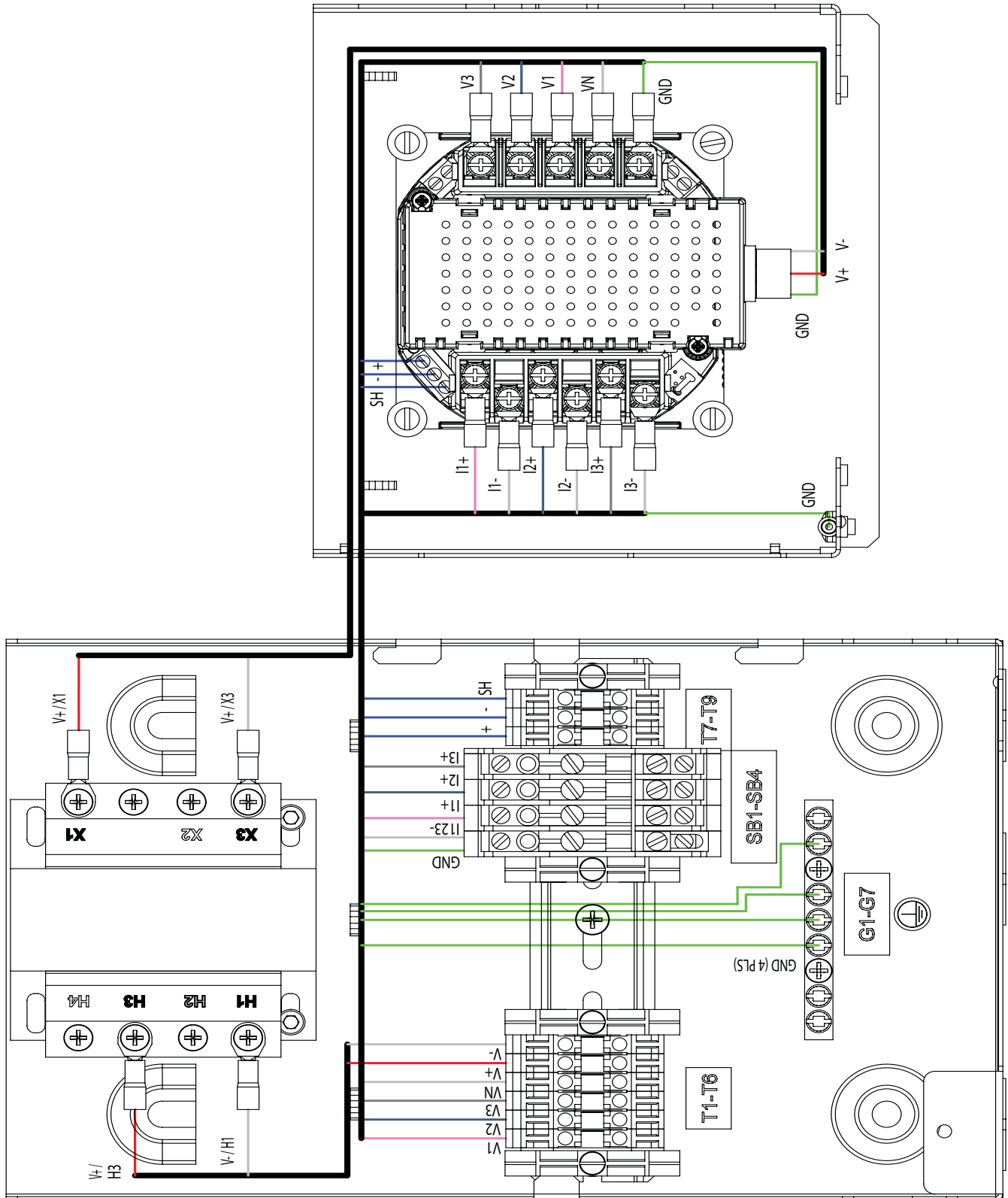

Schneider Electric
295 Tech Park Drive, Suite 100
La Vergne, TN 37086 USA
1-888-778-2733
www.SquareD.com

Electrical equipment should be installed, operated, serviced, and maintained only by qualified personnel. No responsibility is assumed by Schneider Electric for any consequences arising out of the use of this material.

70000-0286-01 09/2007
All Rights Reserved