

Description of functions

RI stored energy operating mechanism Wiring diagram

PE57164



Manual or electrical operation of the RI stored energy operating mechanism

This gives the device an opening and closing speed that is independent of the operator whether the order is electrical or manual.

The electrical control mechanism carries out reclosing cycles and is automatically recharged by a geared motor each time after closing.

It consists of:

- the stored energy operating mechanism which stores in springs the energy required to open and close the device
- a manual lever-operated spring arming device
- a geared electrical arming device which automatically re-arms the control mechanism as soon as the circuit breaker is closed (optional)
- manual order devices by push buttons on the front panel of the device
- an electrical remote closing device containing a release with an antipumping relay
- an electrical opening order device comprising one or several release units which can be of the following type:
 - shunt opening
 - undervoltage
 - Mitop, a low consumption release, used only with the self protection relay.
- an operation counter
- an "open/closed" position indicator device with a mechanical indicator
- a device for indicating "charged" operating mechanism status by mechanical indicator and electrical contact (optional)
- a module of 14 auxiliary contacts whose availability varies according to the diagram used.

Wiring diagram (principle)

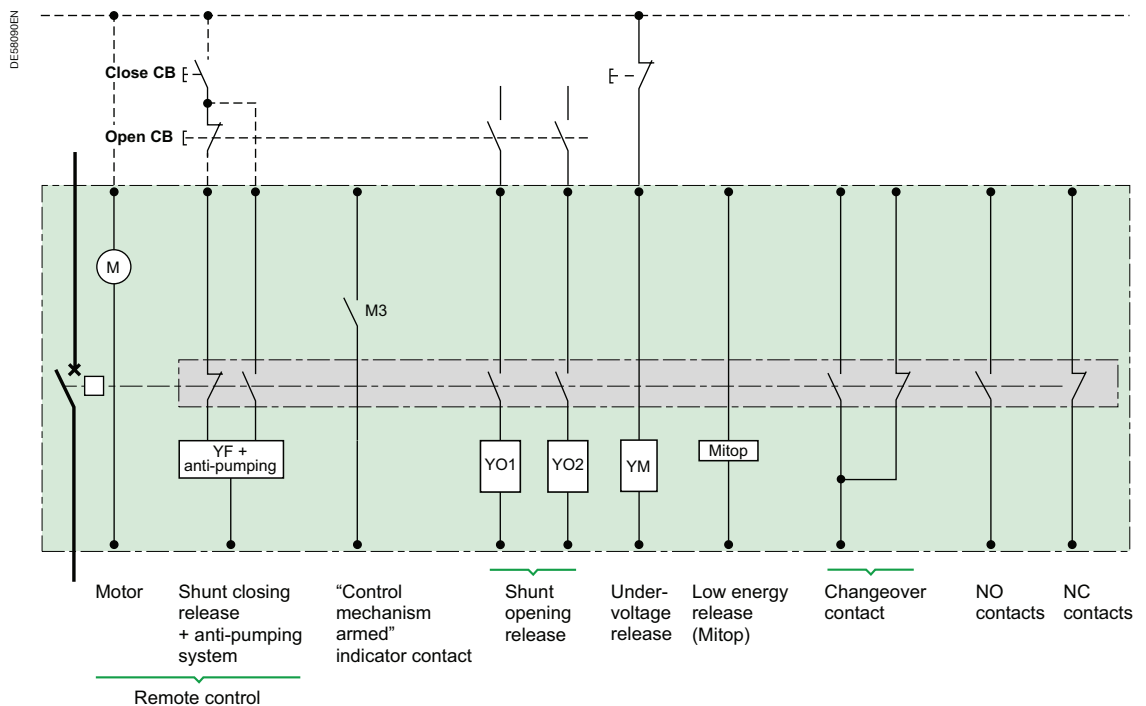

Description of functions

Opening circuit

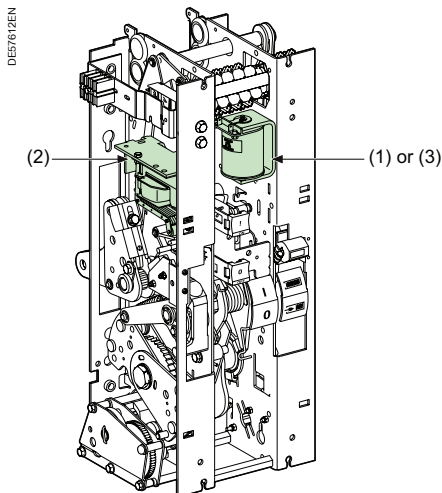

Operating mechanism

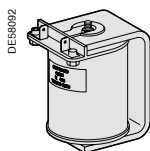

Shunt opening release (1)

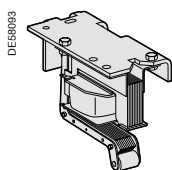

Undervoltage release (2)

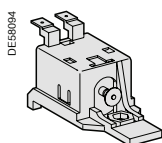

Low energy release (3)

Composition

The opening circuit can be produced using the following components:

- shunt opening release (on energizing) (YO1)
- second shunt opening release (on energizing) (YO2)
- undervoltage release (YM)
- low energy release (Mitop).

Note: see the table of the releases' combinations "Order form" page.

Shunt opening release (YO1 and YO2)

Energizing this unit causes instant opening of the circuit breaker.

Characteristics

Power supply	See "Order form" page	
Threshold	V AC	0.85 to 1.1 Ur
	V DC	0.7 to 1.1 Ur
Consumption	V AC	160 VA
	V DC	50 W

As an option, the tripping circuit monitoring (supervision) enables to ensure that the Circuit breaker is ready to open.

Undervoltage release (YM)

This release unit causes the systematic opening of the circuit breaker when its supply voltage drops below a value less than 35% of the rated voltage, even if this drop is slow and gradual. It can open the circuit breaker between 35% and 70% of its rated voltage. If the release unit is not supplied power, manual or electrical closing of the circuit breaker is impossible. Closing of the circuit breaker is compulsory when the supply voltage of the release unit reaches 85% of its rated voltage.

Characteristics

Power supply	See "Order form" page		
Threshold	Opening	0.35 to 0.7 Ur	
	Closing	0.85 Ur	
Consumption	Triggering	V AC	400 VA
		V DC	100 W
	Latched	V AC	100 VA
		V DC	10 W

Low energy release (Mitop)

This specific release unit comprises a low consumption unit and is specifically used with self-powered relays.

Characteristics

Power supply	Direct current
Threshold	0.6 A < I < 3 A

Any tripping due to the Mitop release unit is momentarily indicated by an SDE type changeover contact.

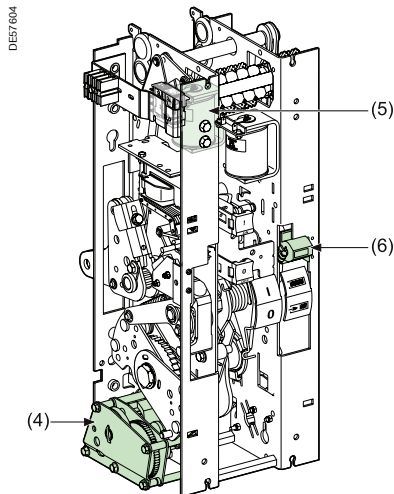

Operating mechanism

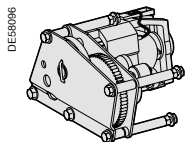

Electrical motor with gearing (4)

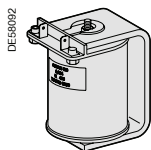

Shunt closing release (5)

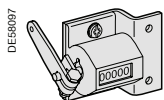

Operation counter (6)

Function

Remote control enables the remote opening and closing of the circuit breaker.

Composition

The remote control mechanism comprises:

- an electrical motor with gearing
- a shunt closing release combined with an anti-pumping device
- an operation counter.

Electrical motor with gearing (M)

The electrical motor arms and re-arms the stored energy unit as soon as the circuit breaker is closed. This allows the instant closing of the device after opening.

The arming lever is only used as a back-up operating mechanism in the case of any auxiliary power supply.

The M3 contact indicates the end of arming operations.

Characteristics

Power supply	See "Order form" page	
Threshold	V AC/V DC	0.85 to 1.1 Ur
Consumption	V AC	380 VA
	V DC	380 W

Shunt closing release (YF)

This allows the remote closing of the circuit breaker when the operating mechanism is armed.

Characteristics

Power supply	See "Order form" page	
Threshold	V AC	0.85 to 1.1 Ur
	V DC	0.85 to 1.1 Ur
Consumption	V AC	160 VA
	V DC	50 W

The anti-pumping relay enables the guaranteeing of opening priority in the case of a permanent closing order. This therefore avoids the device being caught in a uncontrolled opening-closing loop.

Operation counter

The operation counter is visible on the front panel.

It displays the number of switching cycles (CO) that the device has carried out.

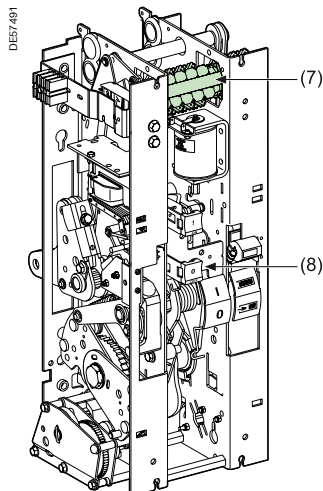

Operating mechanism



Auxiliary contacts (7)

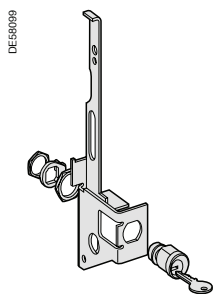

Keylocking kit (8)

“Open/closed” auxiliary contacts

The number of contacts available depends on the options chosen on the operating mechanism.

In the basic configuration, the circuit breaker’s operating mechanism comprises a total of:

- 6 normally closed contacts (NC)
- 7 normally open contacts (NO)
- 1 changeover contact (CHG).

The usage procedure for auxiliary contacts is given in the following table:

Options		
	NC contact	NO contact
Remote control	1	1
Shunt opening release (each one) YO1/YO2	0	1
Undervoltage release YM	0	0
Low energy release (Mitop)	0	0

In order to know the final number of available contacts, you must deduct the total number of contacts included in the circuit breaker (6 NC + 7 NO + 1 CHG), the number of contacts used given in the table above.

E.g.: a circuit breaker equipped with a remote control and a shunt trip unit has the following available contacts:

6 NC + 5 NO + 1 CHG.

With a undervoltage release instead of the shunt trip, this circuit breaker would have the following available contacts:

6 NC + 6 NO + 1 CHG.

Shunt opening release combination				
	1st release	Shunt opening release YO1	Undervoltage release YM	Mitop
2nd release				
Without		6NC + 5NO + 1CHG	6NC + 6NO + 1CHG	6NC + 6NO + 1CHG
Shunt opening release YO2		6NC + 4NO + 1CHG		
Undervoltage release YM		6NC + 5NO + 1CHG		
Mitop		6NC + 5NO + 1CHG	6NC + 6NO + 1CHG	

Locking the circuit breaker in the “open” position

This key-operated device allows the circuit breaker to be locked in the “open” position.

The circuit breaker is locked in the open position by blocking the opening push button in the “engaged” position.

Locking is achieved using a Profalux or Ronis captive key type keylock.