

# StruxureWare™

## Power Monitoring Expert 8.1 Application Modules

### Configuration Guide

7EN42-0131-00

04/2016





## Legal Information

The Schneider Electric brand and any registered trademarks of Schneider Electric Industries SAS referred to in this guide are the sole property of Schneider Electric SA and its subsidiaries. They may not be used for any purpose without the owner's permission, given in writing. This guide and its content are protected, within the meaning of the French intellectual property code (Code de la propriété intellectuelle français, referred to hereafter as "the Code"), under the laws of copyright covering texts, drawings and models, as well as by trademark law. You agree not to reproduce, other than for your own personal, noncommercial use as defined in the Code, all or part of this guide on any medium whatsoever without Schneider Electric's permission, given in writing. You also agree not to establish any hypertext links to this guide or its content. Schneider Electric does not grant any right or license for the personal and noncommercial use of the guide or its content, except for a non-exclusive license to consult it on an "as is" basis, at your own risk. All other rights are reserved.

Electrical equipment should be installed, operated, serviced and maintained only by qualified personnel. No responsibility is assumed by Schneider Electric for any consequences arising out of the use of this material.

As standards, specifications and designs change from time to time, please ask for confirmation of the information given in this publication.

# Safety Information

## Important Information

Read these instructions carefully and look at the equipment to become familiar with the device before trying to install, operate, service or maintain it. The following special messages may appear throughout this bulletin or on the equipment to warn of potential hazards or to call attention to information that clarifies or simplifies a procedure.



The addition of either symbol to a "Danger" or "Warning" safety label indicates that an electrical hazard exists which will result in personal injury if the instructions are not followed.



This is the safety alert symbol. It is used to alert you to potential personal injury hazards. Obey all safety messages that follow this symbol to avoid possible injury or death.

### **⚠ DANGER**

**DANGER** indicates a hazardous situation which, if not avoided, **will result in** death or serious injury.

### **⚠ WARNING**

**WARNING** indicates a hazardous situation which, if not avoided, **could result in** death or serious injury.

### **⚠ CAUTION**

**CAUTION** indicates a hazardous situation which, if not avoided, **could result in** minor or moderate injury.

### **NOTICE**

**NOTICE** is used to address practices not related to physical injury.

## Please Note

Electrical equipment should be installed, operated, serviced and maintained only by qualified personnel. No responsibility is assumed by Schneider Electric for any consequences arising out of the use of this material.

A qualified person is one who has skills and knowledge related to the construction, installation, and operation of electrical equipment and has received safety training to recognize and avoid the hazards involved.

# Safety Precautions

During installation or use of this software, pay attention to all safety messages that occur in the software and that are included in the documentation. The following safety messages apply to this software in its entirety.

<b> WARNING</b>
<b>UNINTENDED EQUIPMENT OPERATION</b>
<ul style="list-style-type: none"><li>• Do not use the software for critical control or protection applications where human or equipment safety relies on the operation of the control action.</li><li>• Do not use the software to control time-critical functions because communication delays can occur between the time a control is initiated and when that action is applied.</li><li>• Do not use the software to control remote equipment without securing it with an authorized access level, and without including a status object to provide feedback about the status of the control operation.</li></ul>
<b>Failure to follow these instructions can result in death or serious injury.</b>

<b> WARNING</b>
<b>INACCURATE DATA RESULTS</b>
<ul style="list-style-type: none"><li>• Do not incorrectly configure the software, as this can lead to inaccurate reports and/or data results.</li><li>• Do not base your maintenance or service actions solely on messages and information displayed by the software.</li><li>• Do not rely solely on software messages and reports to determine if the system is functioning correctly or meeting all applicable standards and requirements.</li><li>• Consider the implications of unanticipated transmission delays or failures of communications links.</li></ul>
<b>Failure to follow these instructions can result in death, serious injury, equipment damage, or permanent loss of data.</b>



# Contents

---

<b>Application Modules</b> .....	<b>11</b>
<b>Breaker Performance</b> .....	<b>12</b>
Breaker Aging Configuration Tool .....	12
Supported devices .....	12
Setting up the system .....	13
Configuring breaker devices .....	17
Configuring switchboards .....	19
Configuring groups .....	21
Pasting the Circuit Breaker Aging framework in VIP .....	23
Opening Vista diagrams and linking the status .....	24
Circuit Breaker Aging Report .....	25
<b>Energy Analysis</b> .....	<b>27</b>
Energy Regression Analysis Report .....	27
Configure and Generate the Energy Regression Analysis Report .....	27
<b>Energy Billing</b> .....	<b>31</b>
<b>IT Billing</b> .....	<b>32</b>
Energy by IT Customer Report .....	32
<b>Emergency Power Supply System (EPSS)</b> .....	<b>34</b>
Configuration Overview .....	35
Emergency Power Supply System (EPSS) .....	35
Sequence of Events .....	36
Generator Performance Configuration Tool with EPSS Test Module .....	39
Start the Generator Performance Configuration Utility with EPSS .....	39
Define Generators for EPSS .....	42
Define Transfer Switches for EPSS .....	51
Define Equipment for EPSS .....	55
Define Groups for EPSS .....	56
View Run History for EPSS .....	60
Generate EPSS Vista Diagrams .....	63
EPSS Test Report .....	68
Report Prerequisites .....	68
EPSS Test Report Example .....	69
Smart Device Data Collector .....	77
Generator and ATS Data Workflow .....	77
Start the Smart Device Data Collector .....	78
Log Data for ATS Load Transfer Tests .....	81

---

Log Generator Data .....	85
<b>Generator Performance .....</b>	<b>88</b>
Generator Performance Configuration Tool .....	89
Start the Generator Performance Configuration Tool .....	89
Define Generators .....	91
Define Equipment .....	93
Define Groups .....	95
View Run History .....	98
Generator Activity Report .....	102
Report Prerequisites .....	102
Configure and Generate the Generator Activity Report .....	103
Generator Activity Report Example .....	104
Generator Battery Health .....	106
Configure the Battery Health Framework .....	107
Battery Health Waveform Capture Results .....	113
Generator Battery Health Report .....	114
Generator Battery Health Export .....	117
Generator Load Summary Report .....	121
Report Prerequisites .....	121
Configure and Generate the Generator Load Summary Report .....	121
Generator Load Summary Report Example .....	122
Generator Test Report .....	124
Report Prerequisites .....	124
<b>Power Capacity .....</b>	<b>125</b>
Branch Circuit Power Report .....	125
Generator Power Configuration Utility .....	126
Generator Configuration Restrictions .....	126
Define generator systems .....	127
Define Generator Groups .....	131
Define Generators .....	132
Define Generator Loads .....	133
Define Generator Utilities .....	133
Generator Power Report .....	134
Generator Power Capacity Measurements .....	134
UPS Power Configuration Utility .....	135
UPS Power Configuration Restrictions .....	135
Define UPS Systems .....	136
Define UPS groups .....	140

Define UPS modules .....	141
Define UPS loads .....	142
UPS Power Report .....	142
UPS Power Report Capacity Measurements .....	142
<b>Power Efficiency .....</b>	<b>144</b>
Power Losses Configuration Utility .....	144
Power Losses Configuration Restrictions .....	145
Define the Power Losses components .....	146
Define Transformers for Power Losses .....	146
Define UPS modules for Power Losses .....	147
Power Losses Report .....	148
Power Losses Reporting Measurements .....	148
Power Usage Effectiveness (PUE) Summary Report .....	150
<b>UPS Performance .....</b>	<b>154</b>
Uninterrupted Power Supply (UPS) Auto Test .....	154
Adding UPSs to Management Console .....	154
Configuring UPS Groups with UPS Configuration Tool .....	154
Generating a Vista diagram .....	156
Pasting UPS framework in VIP .....	157
Setting up Vista Diagram status .....	160
Running a report .....	161
Uninterrupted Power Supply (UPS) Auto Test Report .....	161
Uninterrupted Power Supply (UPS) Battery Health Report .....	163
Configuring the UPS Battery Health Framework .....	164
Configure and Generate the UPS Battery Health Report .....	167
UPS Battery Health Report Example .....	167
<b>Telvent Weather Data Import Service .....</b>	<b>169</b>
Configure the data import service .....	169
Run the Modbus Service Configuration Tool .....	169
Configure the Management Console .....	171
Verifying the service is active .....	174
<b>AccuSine® Power Correction System (PCS) device .....</b>	<b>175</b>
Configuring the AccuSine PCS device .....	175
Verifying the device is active .....	176
<b>Reference .....</b>	<b>178</b>
ION Power Meter Configuration .....	179
Supported ION Power Meters .....	179
Maintenance and Backups .....	180

---

Prerequisites .....	180
Add ION Devices to the System .....	181
Deploying ATS Frameworks for EPSS .....	182
Deploying Generator Frameworks .....	192
Non-ION Power Meter Configuration .....	201
Supported Power Meters .....	201
Prerequisites .....	201
Configuring PM800 Series Meters .....	202
Configuring CM3000 and CM4000 Series Meters .....	220
Configure Auto-Enable Data Logs for CM4000 and PM800 series .....	236
Configuring Momentum PLC .....	239
Configuring SER-2408/SER-3200 .....	250
Adding the SER-2408/SER-3200 to Management Console .....	252
Verify Device Communications in Vista .....	255
Assign Measurements for Generators or ATS Equipment .....	256
Interpreting the Energy Regression Analysis Report results .....	259
Reading the report .....	260
Interpreting the report .....	264
Generator System Redundancy Types .....	266
UPS System Redundancy Types .....	270
Uninterrupted Power Supply (UPS) Battery Health Report calculations .....	278

# Application Modules

In addition to the foundational solution, a set of application modules is available to use with Power Monitoring Expert, and the Data Center and Healthcare Editions (hereafter collectively referred to as Power Monitoring Expert). Depending on your system, these modules enhance the capabilities of Power Monitoring Expert by helping to better manage system equipment, increase power efficiency and capacity, monitor and log data to capture electrical events, and bill tenants.

The following diagram illustrates the application modules that can be used with Power Monitoring Expert:

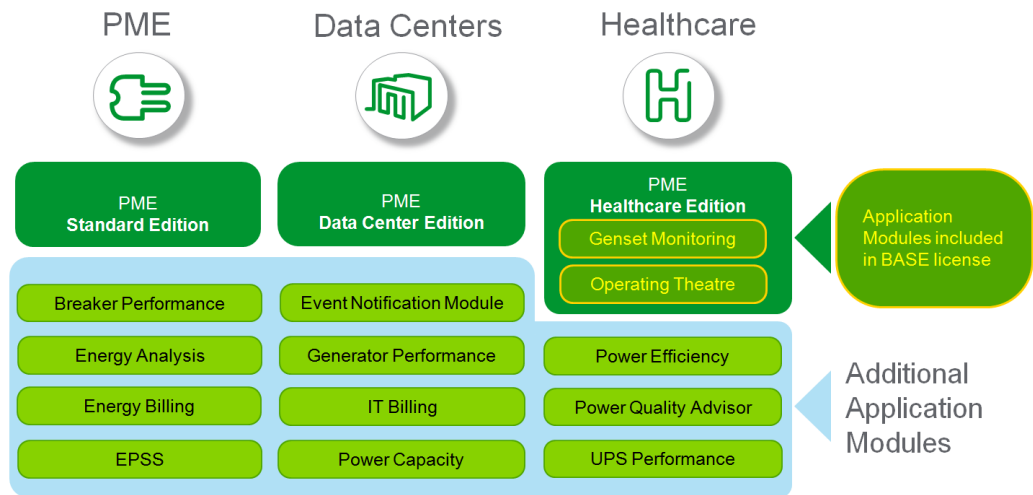

This guide includes detailed information on how to configure the Power Monitoring Expert application modules.

**NOTE:** Each application module requires a license to be used. Contact your Schneider Electric representative for more information.

# Breaker Performance

Breaker Performance Module lets you manage and report on breaker performance and wear.

The Breaker Performance Module includes the following configuration tool and report:

- ["Breaker Aging Configuration Tool" on page 12](#)
- ["Circuit Breaker Aging Report" on page 25](#)

## Breaker Aging Configuration Tool

The Breaker Aging Configuration Tool supplies circuit breaker aging and wear data for devices in your system to Power Monitoring Expert. Using this feature, you can monitor and report on the status of circuit breaker aging and wear in your electrical system.

<b> WARNING</b>
<p><b>INACCURATE DATA RESULTS</b></p> <p>Do not install incorrect drivers for the circuit breakers in your system. This can lead to algorithms not functioning correctly and to incomplete or inaccurate reports and/or data results.</p> <p><b>Failure to follow these instructions can result in death, serious injury, or equipment damage.</b></p>

## Supported devices

The Breaker Aging Configuration Tool in Power Monitoring Expert supports the following devices:

Standard / Country	Circuit Breaker Range	Control Unit Range
IEC	<ul style="list-style-type: none"> <li>• Masterpact NT</li> <li>• Masterpact NW</li> <li>• Compact NS630b-3200</li> </ul>	<ul style="list-style-type: none"> <li>• Micrologic 2 A/E</li> <li>• Micrologic 5 A/E/P/H</li> <li>• Micrologic 6 A/E/P/H</li> <li>• Micrologic 7 A/P/H</li> </ul>
	Micrologic 5.2/6.2/5.3/6.3 A/E	<ul style="list-style-type: none"> <li>• Micrologic 5 A/E</li> <li>• Micrologic 6 A/E/E-M</li> </ul>
China	Compact NS630b-1600	<ul style="list-style-type: none"> <li>• Micrologic 2 A</li> <li>• Micrologic 5 A</li> <li>• Micrologic 6 A</li> </ul>
	Masterpact MT	<ul style="list-style-type: none"> <li>• Micrologic 2 A</li> <li>• Micrologic 5 A/E/D/P/H</li> <li>• Micrologic 6 A/E/D/P/H</li> <li>• Micrologic 7 A/P/H</li> </ul>
	PowerPact H-, J-, and D-Frame	Same as above

Standard / Country	Circuit Breaker Range	Control Unit Range
USA	<ul style="list-style-type: none"> <li>• Masterpact NT for IEC, UL, and ANSI standards</li> <li>• Masterpact NW for IEC, UL, and ANSI standards</li> <li>• Compact NS630b-3200</li> <li>• PowerPact H-, J-, and L-Frame</li> </ul>	<ul style="list-style-type: none"> <li>• Micrologic 2 A</li> <li>• Micrologic 3 A</li> <li>• Micrologic 5 A/P/H</li> <li>• Micrologic 6 A/P/H</li> </ul>
	PowerPact H-, J-, and D-Frame	Same as above

## Setting up the system

### Adding Circuit Breaker devices

Add all necessary Circuit Breaker devices to your Power Monitoring Expert system using the Management Console.

Add any necessary Power E Box devices to the Management Console. These devices are optional for the breaker aging and wear calculations.

For instructions on how to add Circuit Breaker devices to Management Console, see ["Adding the SER-2408/SER-3200 to Management Console" on page 252.](#)

### Starting the ION software Modbus Gateway service

1. Open the Windows Services panel by clicking **Start > Administrative Tools > Services.**
2. Make sure that **ION software Modbus Gateway Service** is both enabled and started/running. If the service is not enabled, then start and enable the service.

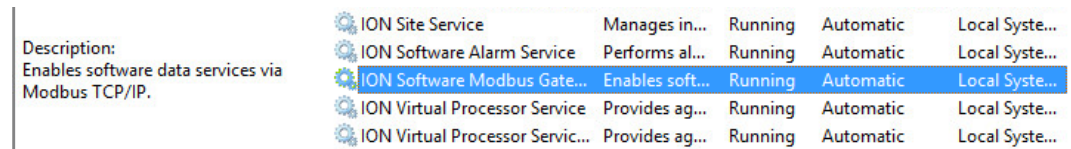

### Adding new calculation service provider

1. In Windows Explorer navigate to `... \[Install path] \system \bin` and double-click **ModbusServiceConfigurationTool.exe** to run it. The configuration dialog appears.
2. Click **Add**. The **Add Service Window** dialog appears.

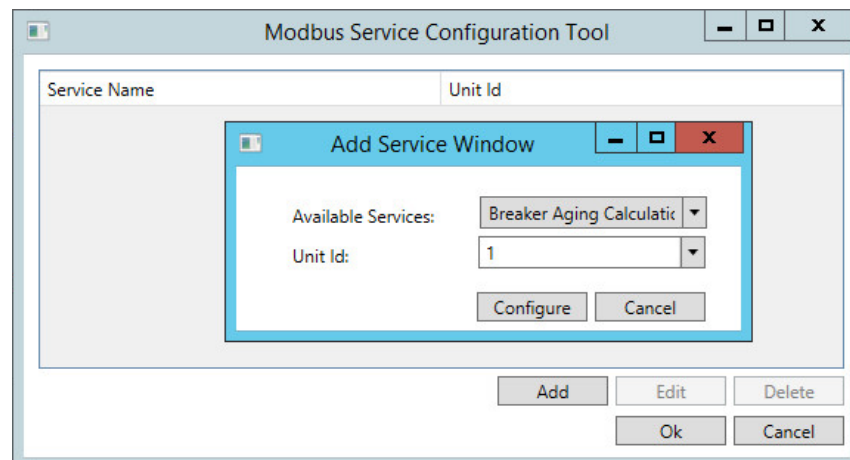

3. **Available Services:** Select **Breaker Aging Calculation Service** from the dropdown list.
4. **Unit ID:** Enter a value of "1" if this is the first service provider you are adding. Otherwise, enter the next logical value for Unit ID.

**NOTE:** If you have already setup the ["Telvent Weather Data Import Service" on page 169](#) and have used UNIT ID = 1, then you must input a unit ID other than 1, (for example, 2).

5. Click **Configure**. The **Breaker Aging Service Configuration** dialog appears. Leave these values as the default.

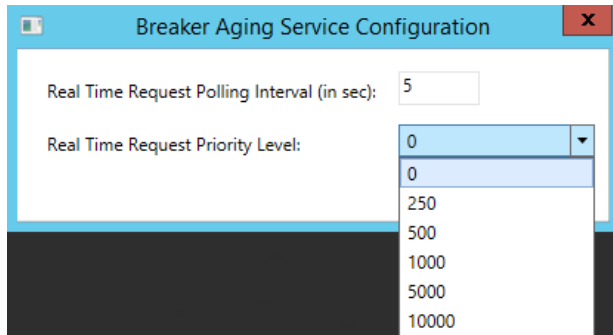

**Note:** These settings are for advanced users only and may be modified if certain load conditions in the system require that the polling priority and frequency of real-time meter data be decreased or increased.

These settings only apply to real-time data requests for breaker aging and wear calculations, and are independent of other types of requests in the system (such as VISTA diagrams, Gadgets, and so forth)

**Real Time Request Polling Interval (in sec):** This is the frequency (in seconds) that is used to request real-time meter data for calculations.

**Real Time Request Priority Level:** This is the level of priority for real-time meter request. The levels are:

Frequency (in seconds)	Priority
0	Low
250	Medium
500	High
1000	Intermediate
5000	Urgent
10000	Control

6. Click **OK** to proceed. The **Breaker Aging Calculation Service** appears in the list.

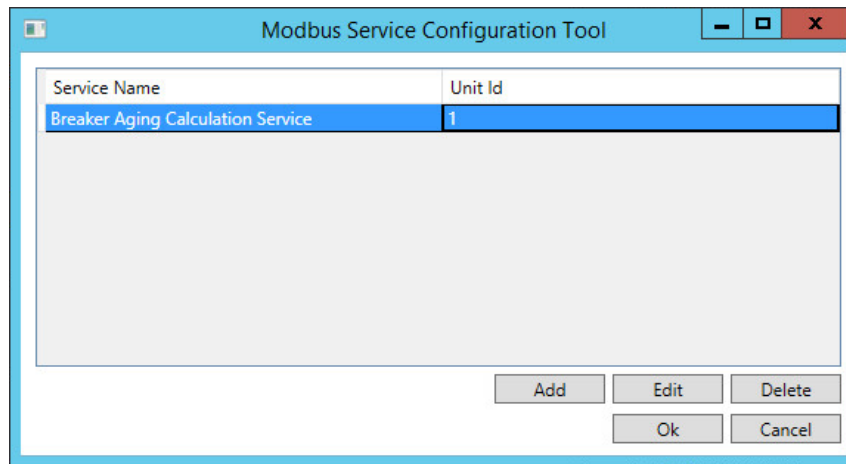

A dialog appears informing you about the configuration change.

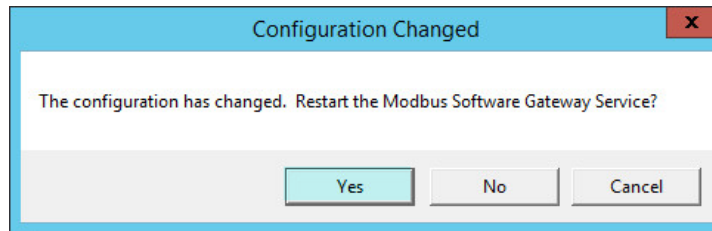

7. Click **Yes** to continue and to restart the Modbus Software Gateway Service.

## Adding new site for the calculation service

Add a new site in Management Console that will communicate with the Circuit Breaker Aging Calculation service.

---

**Note:** These steps are only necessary if you have not yet set up and configured a site for a service (that uses the Modbus Software Gateway Service), such as the **Telvent Weather Data Import Service**. If you have already set up and configured a site for a service, you can ignore the following steps.

---

1. Open **Management Console**. The **Management Console** dialog appears.
2. In the left pane, click **Site**.
3. Right-click on the dialog and choose **New > Ethernet Gateway Site**.

The **Ethernet Gateway Site Configuration** dialog appears. Complete the fields. Items in red are mandatory.

Ethernet Gateway Site Configuration	
Name	BreakerAgingWearSite
TCP/IP Address	STANDALONE
TCP/IP Port	ModbusTCP Device 502
Computer	STANDALONE
Time Synch ION Enabled	No
Time Synch 300X Enabled	No
Time Synch 3720 Enabled	No
Enabled	Yes
Description	

Name  
Enter a name to identify the site.

OK Cancel

4. **Name:** Enter **BreakerAgingWearSite**.
5. **TCP/IP Address:** Enter *<your local PME server IP address>*.
6. **TCP/IP Port:** Enter **ModbusTCP Device|502**.
7. **Computer:** Enter *<your local PME server IP address>*.
8. Click **OK**. The new site is created.

## Adding new device for the calculation service

Add a new device in Management Console to the new BreakerAgingWearSite that will communicate with the Circuit Breaker Aging Calculation service.

1. Open **Management Console**. The **Management Console** dialog appears.
2. In the left pane, click **Device**.
3. Right-click on the dialog and choose **New > Serial Device on Ethernet Gateway Site**. The **Serial Device Configuration** dialog appears. Complete the fields. Items in red are mandatory.

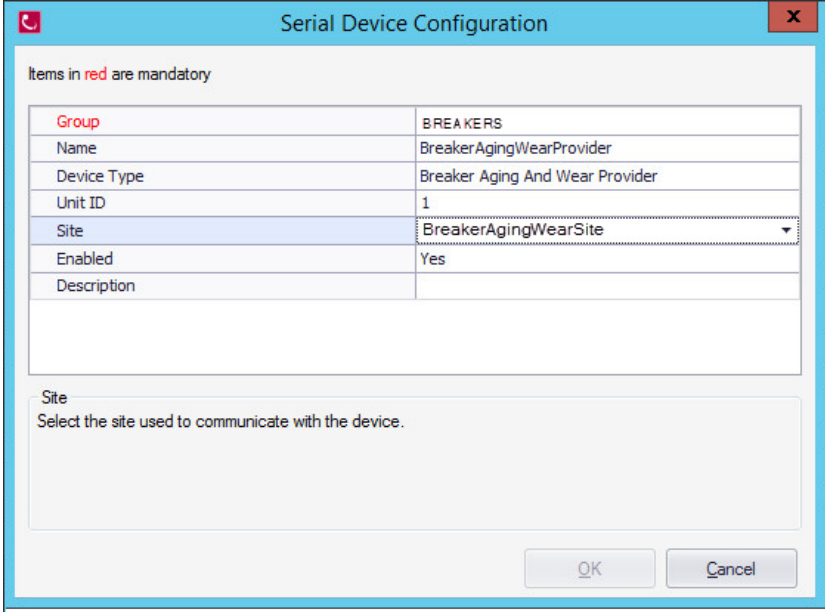

Items in red are mandatory

<b>Group</b>	BREAKERS
Name	BreakerAgingWearProvider
Device Type	Breaker Aging And Wear Provider
Unit ID	1
Site	BreakerAgingWearSite
Enabled	Yes
Description	

Site  
Select the site used to communicate with the device.

OK Cancel

4. **Group:** Enter **BREAKERS**.
5. **Name:** Enter **BreakerAgingWearProvider**.
6. **Device Type:** Enter **Breaker Aging And Wear Provider**.
7. **Unit ID:** Enter the same Unit ID you configured in the Modbus Gateway Service configuration tool.
8. **Site:** Enter the same site name you entered in the configuration tool. Ideally, the site name you enter can be shared for both Breaker Aging and Telvent.
9. **Enabled:** Enter **Yes**.
10. Click **OK**. The new device appears in the list.

## Configuring breaker devices

Use the Breaker Aging Configuration Tool to configure breaker devices.

To configure breaker devices:

1. Navigate to the `... \system\bin` folder and double-click **Breaker Aging Configuration Tool**. If this is the first time you are configuring data, choose the regional setting for circuit breaker and wear library and then click **OK**.

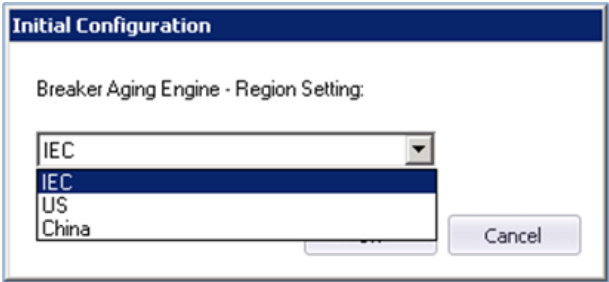

Initial Configuration

Breaker Aging Engine - Region Setting:

IEC  
IEC  
US  
China

Cancel

The **Breaker Aging Configuration Tool** dialog appears.

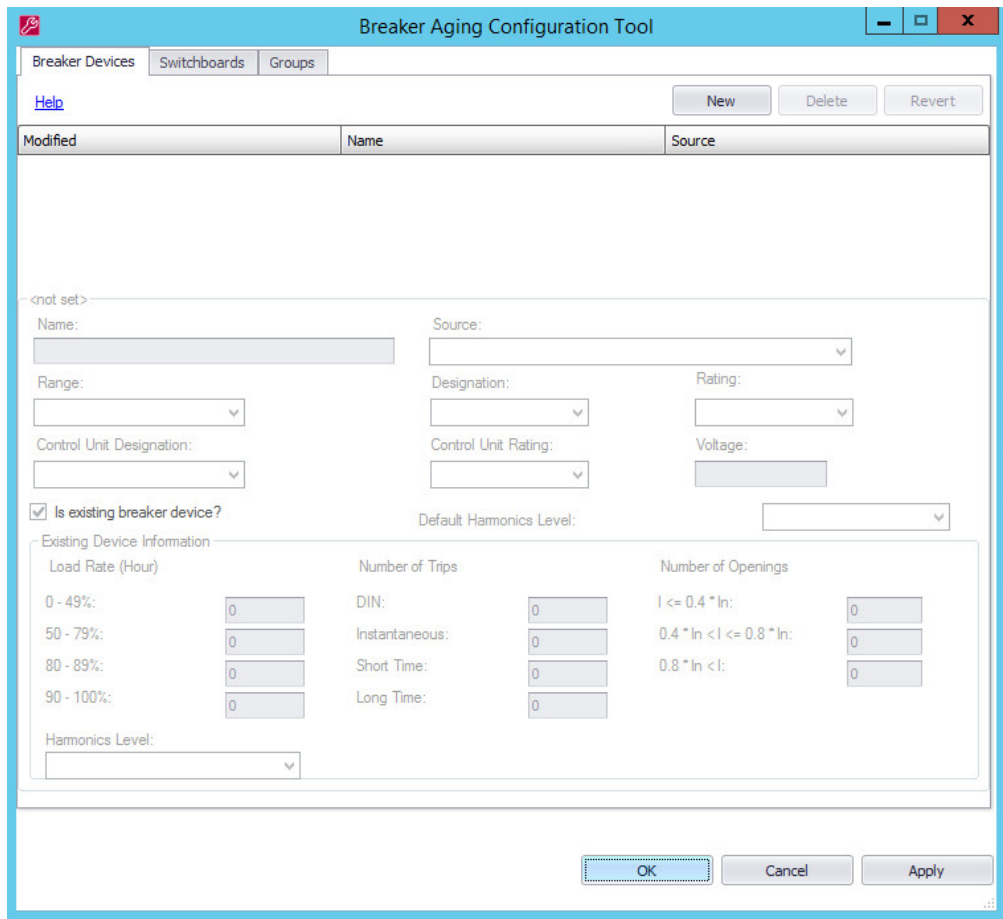

2. Click the **Breaker Device** tab, and then click **New** to add one or more breakers to the system. The configuration dialog appears.
3. For each breaker device enter the following information:
  - **Name:** Enter a unique name to identify this breaker in the generated Vista diagrams and the Circuit Breaker Aging report.
  - **Source:** Associate the device that is to provide data for this breaker (such as load values, total harmonic distortion, and so forth). Note that you can only associate each device in the system with one breaker device.
  - Use the dropdown lists to select values for **Range**, **Designation**, **Rating**, and **Control Unit Rating**.
  - **Voltage:** Enter a value.
4. Click **Is existing breaker device?** if the breaker device already exists in the system.
5. If you select this check box, complete the available fields for each existing breaker device.

## NOTICE

### UNINTENDED OPERATION

If you select the check box for **Is existing breaker device?**, then go to the SEC website and search for "Is existing breaker device." Open and read the knowledgebase article, and then follow the instructions.

**Failure to follow the instructions in the knowledgebase article will result in this feature not functioning as intended.**

After you finish adding and configuring all necessary breaker devices, create any switchboards necessary.

## Configuring switchboards

Use the Breaker Aging Configuration Tool to configure switchboards.

To configure the switchboards:

1. In Windows Explorer navigate to the `... \system\bin` folder and double-click **Breaker Aging Configuration Tool**. If this is the first time you are configuring data, choose the regional setting for circuit breaker and wear library and then click **OK**.

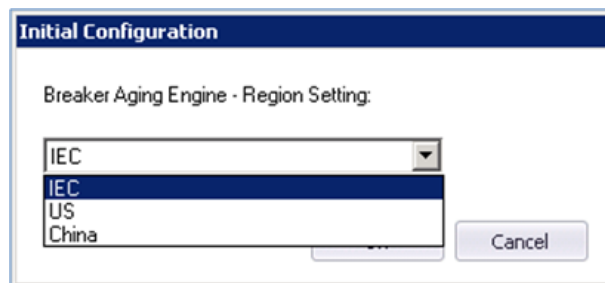

The **Breaker Aging Configuration Tool** dialog appears.

2. Click the **Switchboard** tab, and then click **New** to add one or more Switchboards to the system. The configuration dialog appears.

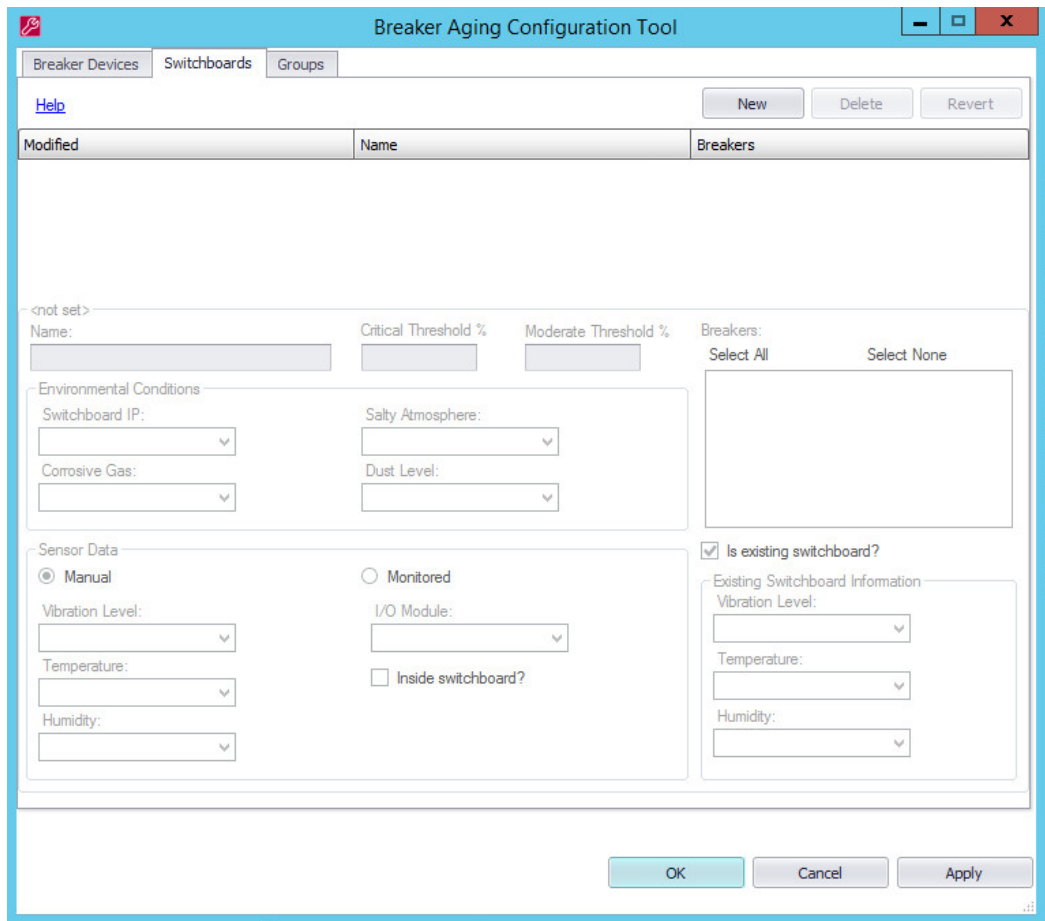

3. For each switchboard enter the following information:

- **Name:** Enter a unique name to identify this switchboard in the generated Vista diagrams and the Circuit Breaker Aging report
- **Critical Threshold %** and **Moderate Threshold %:** Enter default values (0-100%) to be used for each breaker associated with this switchboard when performing analysis of their electrical aging and electrical wear levels.

---

**Note:** If necessary, a Power E Box device can be shared across multiple switchboards.

- **Environmental Conditions:** Use dropdown lists to select values for **Switchboard IP**, **Salty Atmosphere**, **Corrosive Gas**, and **Dust Level**.
- **Sensor Data:** Select one of two modes, and then use the dropdown lists to select values for the parameters.
  - **Manual:** Define static values for humidity, temperature and vibration levels experience in the switchboard.
  - **Monitored:** Associate the switchboard with an optional IO device (Power E Box) in the system that is to provide real-time values for humidity, temperature, and vibration levels measured in the switchboard. If necessary, a Power E Box device can be shared across multiple switchboards. The device must first be configured in the Management Console.

---

**Note:** If you enter a value of "0" (zero), that level is ignored for the calculations.

- **Breakers:** Select one or more breakers from the list. Note that each breaker can be associated with only one switchboard in the system.
4. Click **Is existing switchboard?** if the switchboard already exists in the system.

## **NOTICE**

### **UNINTENDED OPERATION**

If you select the check box for **Is existing switchboard?**, go to the [PME Exchange Community web site](#) and search for "Is existing switchboard." Open and read the knowledgebase article, and then follow the instructions.

**Failure to follow the instructions in the knowledgebase article will result in this feature not functioning as intended.**

5. If you select this check box, use the dropdown lists to complete the fields for **Vibration Level**, **Temperature**, and **Humidity** for each existing switchboard.

After you finish configuring all existing switchboards, create any groups as necessary.

## Configuring groups

Use the Breaker Aging Configuration Tool to configure groups. You must groups in order to generate the Circuit Breaker Aging Report.

To configure groups:

1. Navigate to the `... \system\bin` folder and double-click **Breaker Aging Configuration Tool**. If this is the first time you are configuring data, choose the regional setting for circuit breaker and wear library and then click **OK**.

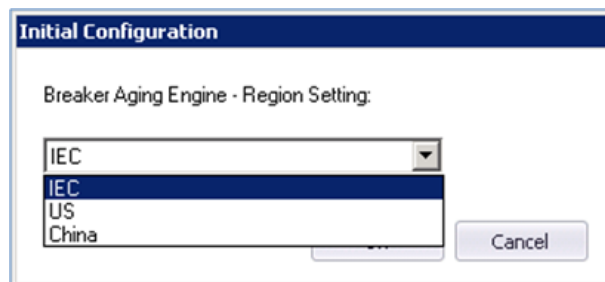

The **Breaker Aging Configuration Tool** dialog appears.

2. Click the **Groups** tab, and then click **New** to add one or more Switchboards to the system. The configuration dialog appears.

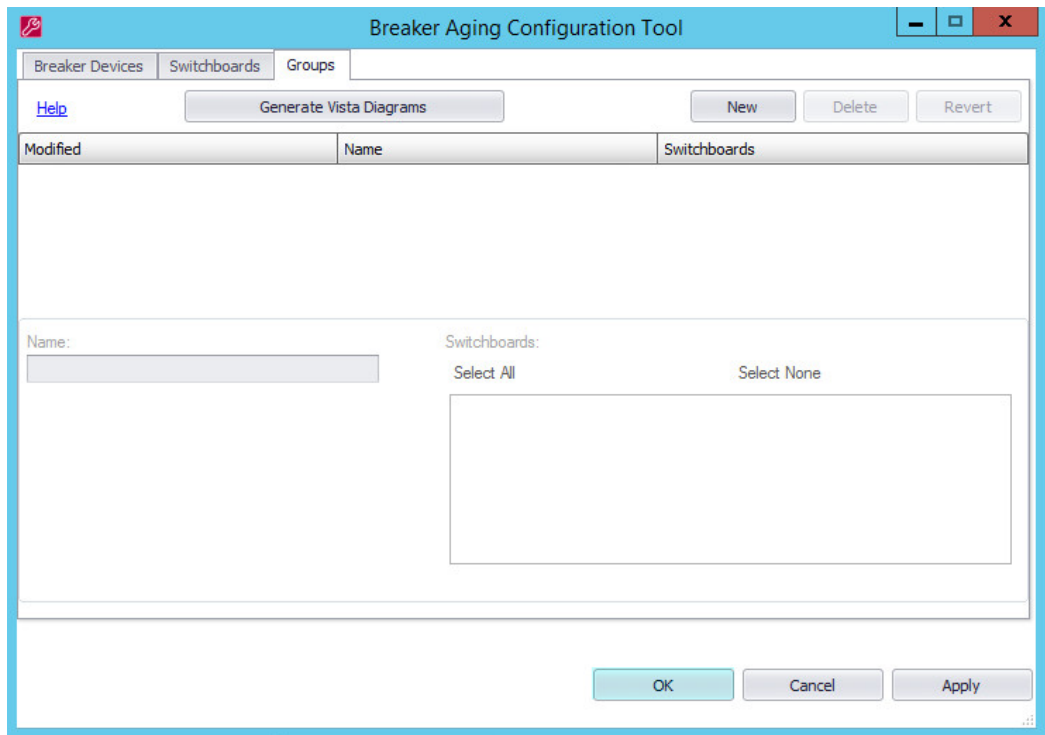

3. For each group enter the following information:
  - **Name:** Enter a unique name to identify this group in the generated Vista diagrams and the Circuit Breaker Aging report
  - **Switchboards** Select one or more switchboards from the list. Note that a switchboard can be used in multiple groups, if necessary.

After you have created all breakers, switchbreakers, and groups, you can generate a set of optional Vista diagrams.

4. Click the **Groups** tab, and then click **Generate Vista Diagrams**. A **Vista Diagram Generation** configuration dialog appears.

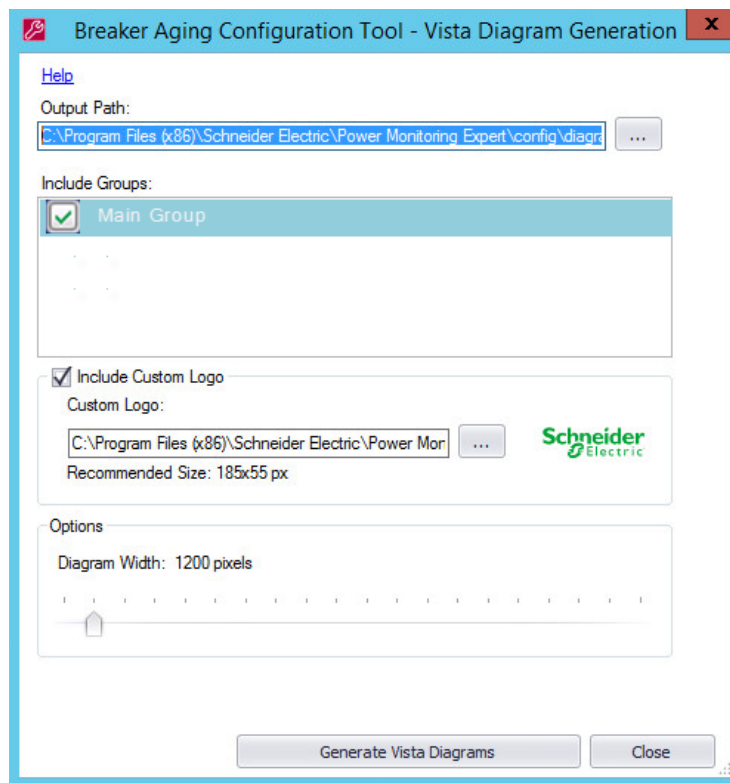

**Note:** The **Output Path** shows the location where the Vista diagram .dgm file is saved after clicking **Generate Vista Diagrams**.

5. Click **Include Custom Logo** and then navigate to and select the file in order to include a custom logo in your diagrams. Otherwise, a Schneider Electric logo appears.
6. Under **Options**, drag the indicator to define the width of Vista diagrams you generate.
7. Click **Generate Vista Diagrams** to generate the .dgm files, then click **OK** and **Close**.

## Pasting the Circuit Breaker Aging framework in VIP

### **⚠ WARNING**

#### **UNINTENDED EQUIPMENT OPERATION**

- ION modules and registers must only be configured by personnel with a thorough understanding of ION architecture and the system in which the meters and software are installed.
- Do not use meters or the software for critical control or protection applications where human or equipment safety relies on the operation of the control circuit.
- Do not use an ION meter's digital output for any safety critical application due to possible unexpected change of state during power cycles, power outages, configuration changes or firmware upgrades.

**Failure to follow these instructions can result in death, serious injury, or equipment damage.**

1. Open the **Designer** tool and open the **VIP.<servername>**. node.

2. Drag a Grouping Object and open it.
3. Go to ...\\config\\fmwk\\BreakerAging\\CB Aging Grouping Status Framework.fwn and select **Edit > Paste** to paste the framework. Depending on the number of Circuit Breakers and groups, you may need to set up the framework.
4. Connect the inputs of each AND/OR module (Circuit Breaker) to the critical operation and battery usage status.
5. Repeat this step for each Circuit Breaker in the group and for all of the Circuit Breakers in the other groups.
6. Save the framework after you finish modifying the framework based on your Circuit Breaker system.

## Opening Vista diagrams and linking the status

1. Log in to Vista, select Open File and then browse to ...\\config\\diagrams\\ud\\BreakerAging\\Groups.dgm.
2. Manually link the status object to the framework you pasted in VIP in the previous steps.

Healthcare example:

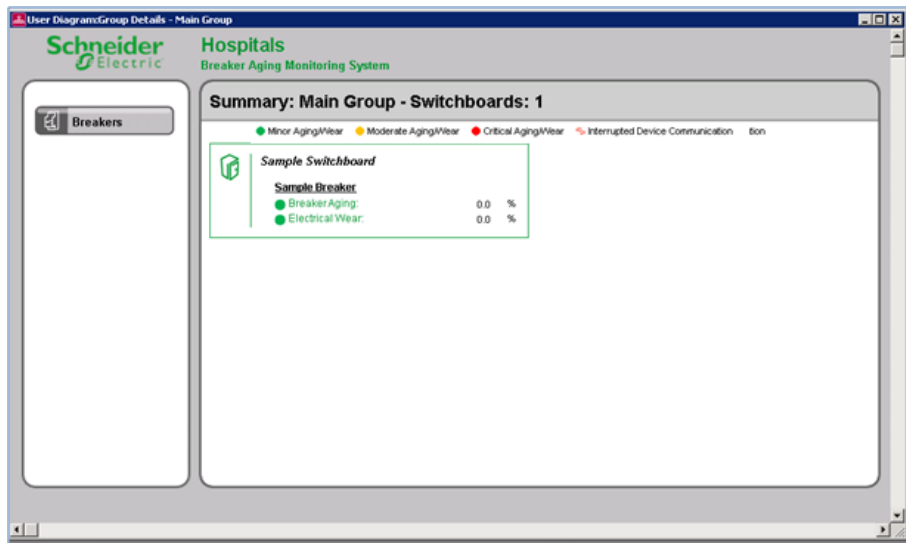

Data Center example:

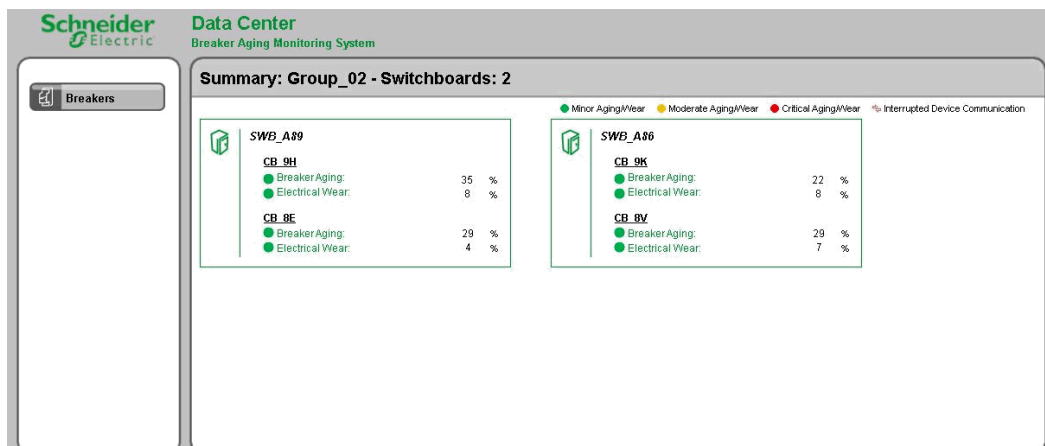

- Repeat this step for all other groups. Your Circuit Breaker Monitoring system is now setup.

For example:

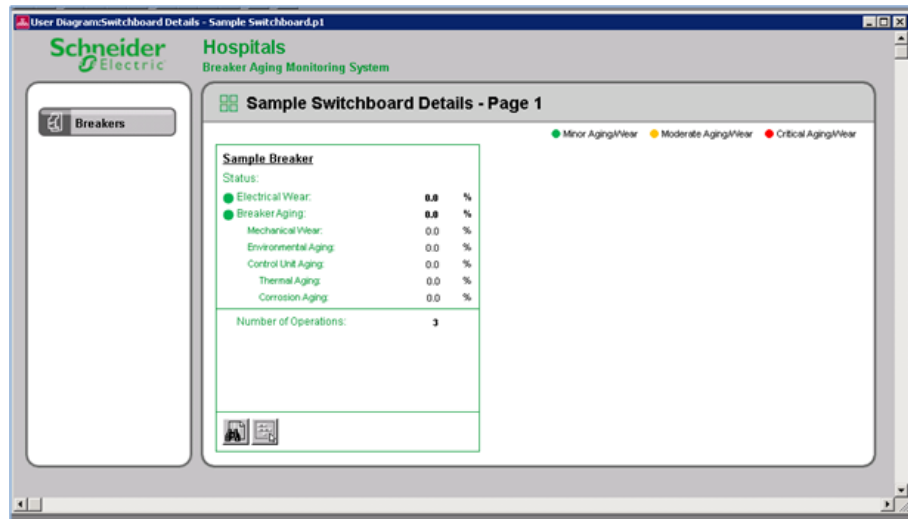

**Note:** Any Circuit Breakers in the groups that require attention show a red LED indicator.

- Manually link the status object from the framework you pasted in the VIP in previous steps.

After you finish configuring all circuit breakers, you can configure and generate the Circuit Breaker Aging Report.

## Circuit Breaker Aging Report

Use Power Monitoring Expert > Web Applications > Reports to configure and generate the Circuit Breaker Aging Report.

- Complete the fields to define the report:

- **Title** - Enter a name for the report. It appears in the header section of the report.
- **Select Group** - Select a group from the dropdown list to be used for determining which switchboards and breakers are used for the analysis.
- **Grouped By** - Select from the dropdown list to determine how the circuit breaker aging and electrical wear analysis results are sorted.

**Switchboard Name first and Threshold Level second** - The results are sorted first by the names (in alphabetical order) of all the switchboards associated with the selected group, and then by the criticality level in descending order of importance (Critical, Moderate, Minor).

**Threshold Level first and Switchboard Name second** - The results are sorted first by criticality level in descending order of importance (Critical, Moderate, Minor), and then by the names (in alphabetical order) of all the switchboards associated with the selected group

- **Include Breakers with Minor Aging and Wear** - Select Yes or No. Selecting Yes allows all of the breakers to appear in the report regardless of the current electrical aging and electrical wear levels. Selecting No allows only breakers with moderate or critical electrical aging and electrical wear to appear.

- **Include Data Warnings** - Select Yes or No.
2. Click **Generate Report** to produce the report.

For more information on generating and managing reports, see the "Reports" section of the Web Applications help file.

# Energy Analysis

The Energy Analysis Module lets you understand energy usage patterns to find energy waste, analyze transformer and circuit capacity as configurations change, determine what factors contribute most to energy usage, and assess energy usage by process area or by product output.

The Energy Analysis Module consists of the following reports:

- ["Energy Regression Analysis Report" on page 27](#)
- Duration Curve Report <sup>1</sup>
- Energy Usage per State Report <sup>1,2</sup>
- Multi Equipment Operation Reports <sup>1,2</sup>
- Power Usage per State Report <sup>1,2</sup>
- Single Equipment Operation Reports <sup>1,2</sup>

1. For more information on how to use the Energy Analysis reports, see Power Monitoring Expert Web Applications help.

2. For more information on how to configure the equipment state reports, see the *Power Monitoring Expert Equipment State Report Configuration Guide* on the PME Exchange Community.

## Energy Regression Analysis Report

The **Energy Regression Analysis** report allows you to analyze building energy systems, monitor energy consumption, and monitor for anomalies or changes in system behavior. Based on the report results, you can perform energy efficiency upgrades or fixes as needed, or model energy data one independent variable at a time with a wide range of desired independent variables.

## Configure and Generate the Energy Regression Analysis Report

Use the Reports module in Web Applications to configure and generate the Energy Regression Analysis Report.

1. Complete the fields to define the report:
  - **Title** - Enter a name for the report. It appears in the header section of the report.
  - **Driver Data Source** - Select a grouping and single source for the report.
  - **Driver Data Quantity** - Select a grouping and a corresponding single quantity that is used to calculate the values for the X-axis of the Regression Analysis Chart. For example, you can use a weather data source and quantity as the driver for the model you intend to generate.
  - **Model Data Source** - Select a grouping and single source for the report.

- **Model Data Quantity** - Select a grouping and a corresponding single quantity that is used to calculate the values for the X-axis of the Regression Analysis Chart. For example, you can use a building electrical consumption data source and quantity as the input data for the model you intend to generate.
- **Reporting Period** - Select from the list to specify a period of time for the report that is used to query data from the database for driver and model data. Select the server time from the next dropdown list.
- **Regression Type** - Select Single Line or Broken Line as the type of line to be used in the report.
- **X-Axis Calculation Method** - Select how data is grouped for the X-axis values from these calculation method options: Cooling Degree Days (CDD), Heating Degree Days (HDD), Average (AVG), Sum, and Delta.

Driver quantity data is retrieved differently depending on which calculation method you select:

- **Cooling Degree Days**: All data points within the selected reporting period that are above the Degree Days Pivot Point temperature are retrieved from the database. Any data point at or below the Degree Days Pivot Point temperature is set to 0.
- **Heating Degree Days**: All data points within the selected reporting period that are below the Degree Days Pivot Point temperature are retrieved from the database. Any data point at or above the Degree Days Pivot Point temperature is set to 0.
- **Average**: All data points within the selected reporting period are retrieved from the database.
- **Sum**: All data points within the selected reporting period are retrieved from the database, and values are summed with previous points as they are inserted into the X data table.
- **Delta**: All data points within the selected reporting period are retrieved from the database, and values are calculated by subtracting previous points before inserting them into the X data table.

---

**NOTE:** This parameter depends on selecting the Driver Data Quantity parameter. You can select either "Cooling Degree Days" or "Heating Degree Days" only if the driver data is weather temperature data in Celsius or Fahrenheit degrees.

- 
- **Degree Days Pivot Point** - Enter a value in degrees Celsius to define what the base temperature in the heating degree days and cooling degree days calculations. By default, this value is set to 18, which represents 18 degrees Celsius.

---

**NOTE:** This parameter depends on selecting the Driver Data Quantity parameter. The units for this value must match the units for the Driver Data Quantity value.

- 
- **Y-Axis Calculation Method** - Select how data is grouped for the Y-axis values from these calculation method options: Average, Sum, and Delta.

Model quantity data is retrieved differently depending on which calculation method you select:

- **Average**: All data points within the selected reporting period are retrieved from the database.

- **Sum:** All data points within the selected reporting period are retrieved from the database, and values are summed with previous points as they are inserted into the Y data table.
- **Delta:** All data points within the selected reporting period are retrieved from the database, and values are calculated by subtracting previous points before inserting them into the Y data table.

---

**NOTE:** This parameter depends on selecting the Model Data Quantity parameter. Select **Sum** only if the model data is interval data. Select **Delta** only if the model data is cumulative data.

---

- **Aggregation Interval** - Select how driver and model data will be combined to be processed from these two options:
  - **Day** - For daily aggregation, the data collected over the designated reporting period is grouped into days, and an average value is taken for each day.
  - **Week** - For weekly aggregation, the data collected over the designated reporting period is grouped into weeks, and an average value is taken for each week.
- **Exclude Incomplete Weeks** - Determines whether or not incomplete sets of data from the report calculations are removed.

When you select **Yes**, any week that does not have a value very close to the start (within the first hour of the first day of the week) and a value very close to the end (within the last hour of the last day of the week) is considered incomplete, and any data for that week will be disregarded.

This parameter depends on the Aggregation Period parameter. This check is only used when you select "Week" for the aggregation period.

- **Exclude Incomplete Days** - Determines whether or not incomplete sets of data from the report calculations are removed.

When you select **Yes**, then any day that does not have at least 80% of the calculated average number of values collected per day is considered incomplete, and any data for that day will be disregarded.

This parameter depends on the X- and Y- Axis Calculation Method parameters. This check is used on both axes when you select "CDD," "HDD," "AVG," or "Sum."

- **Exclude Days with Rollover** - Determines whether or not an incorrect set of data from the report calculations is removed due to a meter register rollover.

When you select **Yes**, then if the absolute value of the data point at the end of the day is greater than the absolute value of the data point at the beginning of the day, rollover has occurred, and any data for that day will be disregarded.

This parameter depends on the Y- Axis Calculation Method parameter. This check is only used on the Y-axis when you select "Delta."

- **Deviation Type** - Allows you to select "Percent" or "Absolute Value" deviation type from the list to specify how the report determines when data exceptions appear in the report charts and tables. These deviations refer to discrepancies in the Y-axis between the ideal regression line and real data points.

There are two deviation types:

- **Percent** - Select "Percent" to specify that the maximum authorized deviation value has percentage units. Exceptions are displayed on the charts and logged in the Exceptions Table for any data points whose Y value falls outside of the designated percent range above or below the ideal regression line. This range will grow as one shifts rightwards along the regression line and Y values become larger.
- **Absolute Value** - Select "Absolute Value" to specify the maximum authorized deviation value has the same units as the Y-axis measurement. Exceptions are displayed on the charts and logged in the Exceptions Table for any data points whose Y value falls outside of the designated value range above or below the ideal regression line. This range will stay constant as one shifts rightwards along the regression line.
- **Max Authorized Deviation** - Enter a value in the field. This parameter depends on what you select for Deviation Type. If you select "Percent," the units for Max Authorized Deviation will be percent. If you select "Absolute Value," the units for Max Authorized Deviation will correspond to the units for the Model Data Quantity.
- **Include Data Warnings** - Select "Yes" to include informational messages related to the report, or "No" to exclude these messages.
- **Include Report Parameters Summary** - Select "Yes" to include a summary of the input parameters at the beginning of the generated report, or select "No" to exclude them.

2. Click **Generate Report** to produce the report.

See ["Interpreting the Energy Regression Analysis Report results" on page 259](#) for information on reading and interpreting the report.

For more information on generating and managing reports, see the "Reports" section of the Web Applications help file.

# Energy Billing

The Energy Billing Module is a fully functional energy-based billing reporting system that consists of the following reports:

- Billing Report
- Billing Summary Report
- Multiple Billing Report
- Multiple Billing Export Report

For more information on how to use the Billing module, see the [Billing Module Toolkit](#) on the PME Exchange Community web site

# IT Billing

The IT Billing Module provides information on energy usage for use within a data center facility for billing purposes.

The IT Billing Module includes the ["Energy by IT Customer Report" on page 32](#).

The IT Billing Module also includes the ["Energy Billing" on page 31](#).

## Energy by IT Customer Report

The Energy by IT Customer Report is used by data center operators to generate a report that provides information regarding energy usage for customers within the data center facility.

---

**NOTE:** This report requires a license to be used. Contact your Schneider Electric representative for more information.

---

Use the Energy by IT Customer Report to:

- Troubleshoot your billing system
  - Export your billing system (for CSV export)
  - Examine customer specific energy usage.
- 

**NOTE:** For the Energy by IT Customer Report to provide accurate information, devices must be installed, configured, and communicating correctly, the hierarchy must be set up and configured correctly, and the Managed Circuits feature run each time a device configuration change is made. If any of these tasks are not performed correctly, your reports will provide inaccurate information.

---

For more information on generating and managing reports, see the "Reports" section of the Web Applications help file.

---

**NOTE:** Report output will vary depending on which hierarchy you are using.

---

### Energy by IT Customer Report Example

The Energy by IT Customer Report data depends on the selections you make while configuring the report and the contents of the Power Monitoring Expert or Data Center database.



IT Energy Billing  
Facility A  
Victoria, British Columbia

Peak Demand Timestamp: Calculated by Customer 7/31/2015 12:00:00 AM - 8/7/2015 12:00:00 AM (Server Local)

**Customer Summary**

**Data Warnings**  
No data warnings.

Customer	Time Range	Energy (kWh)	Peak Demand (kW)	Peak Current (A)	Peak Timestamp
Customer 1	7/31/2015 - 8/7/2015	4,233.6**	25.2	210.0	7/31/2015 12:15:00 AM**

\* Value estimated  
\*\* Value based on incomplete data  
\*\*\* Expected value missing

# Emergency Power Supply System (EPSS)

The Emergency Supply System (EPSS) Module is a licensable module you can add to Power Monitoring Expert solutions.

Power Monitoring Expert provides data monitoring and logging to capture electrical events and readings. The EPSS module provides the specific tools and reports to help facilities manage the power data specifically for EPSS tests or during loss of power from a main utility.

Schneider Electric or Schneider Electric System Integrators generate reports that government and organizational inspectors may view as an aid to help determine if an EPSS is in an adequate state to generate electrical power during a utility outage.

---

**NOTE:** A Power Monitoring Expert system supports both Open Transition Transfer (OTT) and Closed Transition Transfer (CTT). By default, the Power Monitoring Expert system is set for OTT. However, if your customer needs to run a CTT test, navigate to the [Power Monitoring Expert Exchange Community](#) web site, in the Install and Maintain section, and then download and run the necessary SQL script.

---

In addition to the features provided by the base system, the EPSS provides these capabilities:

- **Vista diagrams** – Generates the system Vista diagrams based on the transfer switch and backup generator configuration.
- **Real-time data in Vista** – Diagrams show electrical data, generator status, transfer switch status and electrical data, and fuel management data.
- **EPSS Test Report** – A comprehensive report of load supporting capabilities for the transfer switches, generators, and equipment. You can use this report to evaluate the overall condition of the EPSS.
- **Run history viewer** – Displays Test, Load Shedding, and Power Outage run activities stored in the system history.
- **Smart Device Data Collector**– Displays ATS load transfer data, logs standard data for generators, and can also log custom data values.

## WARNING

### INACCURATE REPORT RESULTS

- Do not incorrectly configure the EPSS system, this can lead to inaccurate reports and/or data results.
- Do not rely solely on EPSS reports to determine if the EPSS system is functioning correctly or meeting all applicable standards and requirements.
- Use EPSS reports as a supplement to proper workplace practices or equipment maintenance, not as a substitute.

**Failure to follow these instructions can result in death, serious injury, or equipment damage.**

## Configuration Overview

To configure Power Monitoring Expert with the EPSS Test module, follow these steps:

1. Obtain and install a license for the EPSS Test module.
2. Set up the installed ION meters, including ATS and generator frameworks. See ["ION Power Meter Configuration" on page 179](#) for details.
3. Set up the installed non-ION meters, including digital and analog outputs. See ["Non-ION Power Meter Configuration" on page 201](#) for details.
4. Generate and configure Vista diagrams of EPSS equipment. See ["Generate EPSS Diagrams" on page 64](#).
5. Set up reporting entities in the configuration tool. See ["Generator Performance Configuration Tool with EPSS Test Module" on page 39](#).
6. Configure and run the EPSS Test Report. See ["EPSS Test Report" on page 68](#).
7. (Optional) Configure and run the Smart Device Data Collector. See ["Smart Device Data Collector" on page 77](#).

Before you start the configuration process, review the following sections to learn more about the EPSS Test module.

## Emergency Power Supply System (EPSS)

An Emergency Power Supply System (EPSS) provides emergency electrical power to any facilities requiring continuous power, 24 hours a day, 7 days a week. Among these facilities are hospitals and medical centers.

In many jurisdictions, hospitals and medical centers need to test their emergency power supply systems on a periodic basis and keep records of such tests. Hospitals and medical centers in the USA, for example, must meet the standards specified by the Joint Commission on Accreditation of Hospital Organizations (JCAHO) to operate their facilities.

These standards include the testing of generator systems. These JCAHO standards are derived from both National Fire Protection Association (NFPA) and National Electrical Code (NEC) requirements.

Power Monitoring Expert uses the Generator Performance Configuration Tool with EPSS Test Module to generate reports that government and organizational inspectors may view as an aid to help determine if an EPSS is in an adequate state to generate electrical power during a utility outage. These reports demonstrate compliance not only with the JCAHO standards, but also with the standards mandated by many other geographies, such as:

- National Electric Code Article 220.87 for the United States of America.
- HTM 0601 for the United Kingdom.
- AS/NZS 3009 for Australia and New Zealand.
- 60364-7-710 for Europe.
- CSA Z32 for Canada.

## Sequence of Events

The following diagram represents what happens in a backup power system when the power supply system is tested.

The diagram depicts:

- The ATS events Normal, Test, and Emergency along the top.
- The corresponding GEN (generator) events Stop, Start, and Running along the bottom.

These ATS and GEN events are required by the Test Report to execute its logic.

You can use this diagram to identify which events in the power system correspond to the ATS and GEN events represented in the diagram, and to help ensure that the correct signals are wired to the meter's digital inputs.

The diagram also identifies which events are used to control logging of Analog and Load Profile data, shown beginning at GEN Start in the diagram.

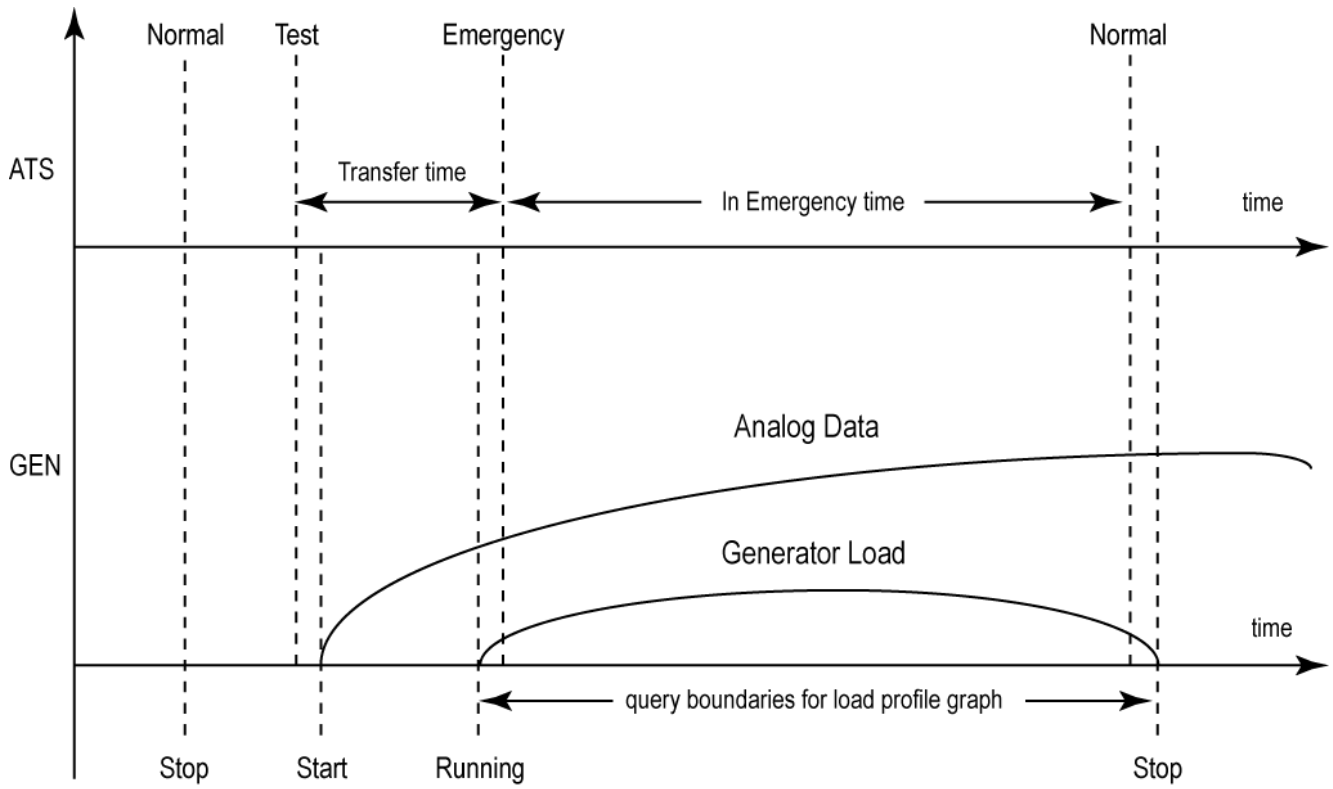



# Generator Performance Configuration Tool with EPSS Test Module

The Generator Performance Configuration Tool with EPSS Test Module is an application that helps you configure the transfer switches, generators and other equipment for reporting the data and status of the power system, including EPSS components. The reports will not work until the required parameters in the tool are set up.

In the configuration tool, you can also generate the Vista diagrams for the configured devices. This feature of the tool produces the diagrams faster than building the diagrams manually. Generated diagrams may still need some adjustment—you can use Vista to finalize the diagrams

After your system is configured using the Generator Performance Configuration Tool, you can use the following generator-related reports:

- Generator Activity Report
- Generator Battery Health Report
- Generator Capacity Report (available for Power Monitoring Expert 8.1 Healthcare Edition only)
- Equipment Capacity Report (available for Power Monitoring Expert 8.1 Healthcare Edition only)
- EPSS Test Report (requires a license for the EPSS Module)

---

**NOTE:** If your installation does not include the EPSS, see "[Generator Performance Configuration Tool](#)" on page 89.

---

## Prerequisites

- Before opening the configuration tool, make sure the sources - which represent metering devices - are added in Management Console and they are communicating.

## Start the Generator Performance Configuration Utility with EPSS

To start the Generator Performance Configuration Tool with EPSS Test Module, open the StruxureWare Power Monitoring Expert folder on the desktop and double-click the Generator Performance Configuration Tool shortcut.

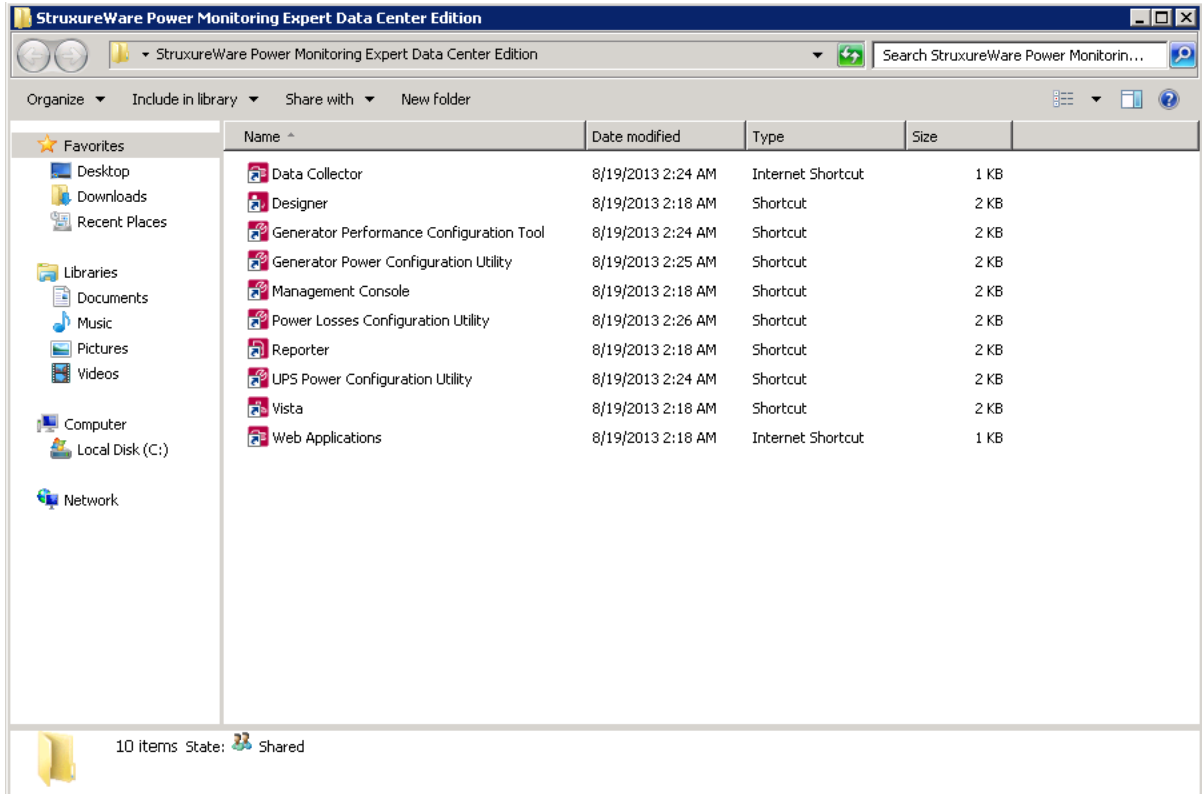

The Generator Performance Configuration Tool with EPSS Test Module window contains these tabs: **Groups**, **Generators**, **Transfer Switches**, **Equipment**, and **Run History**. On these tabs, you create the entities and groups for equipment in the system. You also create Vista diagrams and view data for prior test run results. Use the tabs to define new entities or update existing entities.

When you first use the configuration utility, define generators, transfer switches, and other equipment on the applicable tabs. After you do this, define the device groups on the **Groups** tab. The device groups are necessary for reporting and Vista diagrams.

Use the following tabs to configure the tool:

- **Groups** tab - ["Define Groups for EPSS" on page 56](#)
- **Generators** tab - ["Define Generators for EPSS" on page 42](#)
- **Transfer Switches** tab - ["Define Transfer Switches for EPSS" on page 51](#)
- **Equipment** tab - ["Define Equipment for EPSS" on page 55](#)
- **Run History** tab - ["View Run History for EPSS" on page 60](#)

Use the following common controls for the tabs:

- **Help** - Click this to view online help for the tab.
- **New** - Creates a new entry in the grid.
- **Delete** - Deletes the selected entry from the grid.

- **Revert** - Returns a modified record to its original values, if **OK** or **Apply** have not been clicked.
- **OK** - Saves all changes and exits the configuration tool.
- **Cancel** - Exits the tool without saving changes.
- **Apply** - Saves all changes and leaves the tool open.

The **Modified** column in the grid area shows the status of the row data:

+ (plus) - a new entry.

\* (asterisk) - a modified entry.

! (exclamation mark) - entry needs more information before it can be saved.

## Define Generators for EPSS

Use the **Generators** tab to create or update entities representing the generators in the emergency power supply system. Configure this tab to successfully generate reports for generator data. After you configure, you can generate the Generator Test, Generator Load Summary, Generator Capacity, and the Generator Battery Health reports from this information.

The screenshot shows the 'Generator Performance Configuration Tool with EPSS Test Module - Power Monitoring Expert for Healthcare' window. The 'Generators' tab is active, displaying a table of generator entries. The 'Prairie Heart Gen' entry is selected, and its configuration details are shown in the lower panel.

Modified	Name	Description	Source	Nameplate Rating	Nameplate Unit	Evaluation Method
	Pavillion Gen	Test Auto	PAV.GEN	750	kW	Load
*	Prairie Heart Gen	Test Auto	PHI.GEN	500	kW	Load
	Test Generator	Test Auto	Warp.7650	1	kVA	Load
	Warp Generator	Test Auto	Warp.GeneratorOne	1200	kW	Load

The configuration panel for 'Prairie Heart Gen' includes the following fields:

- Name:** Prairie Heart Gen
- Description:** Test Auto
- Electrical Data:**
  - Source: PHI.GEN
  - Prime Nameplate Rating: 500
  - Unit: kW
- Engine Temperature Data:**
  - Source: Unassigned
  - Unit: C
  - Measurement: Unassigned
- Exhaust Gas Temperature Data:**
  - Source: Unassigned
  - Unit: C
  - Measurement: Unassigned
  - Single Exhaust (selected) / Dual Exhaust
- Evaluation Method:** Load
- Engine Data Measurements:** Assign Engine Data
- Status Measurements:**
  - Source: PHI.GEN
  - Starting: No Measurement selected. Active Value: 1
  - Running: A-55 Status (PM8M26). Active Value: 1
  - Stopped: A-55 Status (PM8M26). Active Value: 0
  - Monitor for EPS Available?: No Measurement selected. Active Value: 1, Req. Time (Seconds): 1
- Battery Waveforms:**
  - Source: Unassigned
  - Measurement: Unassigned

You can perform the following actions on this tab:

- Click **New** to define the properties of the generators in the system. See ["Edit Generator Properties" on page 43](#).
- Click **Clone** to define a new generator that is similar to an existing generator. The system copies many details of the existing device into the new entry. You can then enter the unique details of the new device. If you need to define several devices that are similar, this feature can help you define them quickly. See ["Clone Generator Properties" on page 46](#).
- Click **Delete** to remove records from the system.
- Click **Revert** (before you click **Apply** or **OK**) if you make changes to a record and want to revert to your initial settings.

## Edit Generator Properties

The **Edit Generator** area on the tab is used to create a generator entry and to define specific values for it.

1. On the **Generator** tab, click **New**.
2. Complete the following fields to define a generator.
  - **Name** - Enter a unique name to identify the generator.
  - **Description** - optional. You can add specific information about the generator, such as make and model.

### Electrical Data

- **Source** - Select a source name from the dropdown list. The source represents the device that records the electrical data from the generator.
- **Prime Nameplate Rating** - Enter the maximum power load for the generator. Refer to the generator's nameplate for this value.
- **Unit** - Select the unit of measurement for the power load.

### Engine Temperature Data

- (Optional) To capture engine temperature data, check the box and complete these fields:
  - **Source** - Select a source name. The source represents the device that records the engine temperature of the generator.
  - **Measurement** - Select the engine temperature measurement.
  - **Unit** - Select either F (for Fahrenheit) or C (for Celsius) for the temperature unit of measurement.

The Evaluation Method does not convert units from one type to another. Set the Unit type for Engine Temperature Data on the **Generators** tab to the same Unit type in the Evaluation Method.

- Click **Edit Evaluation Method** to open the **Evaluation Method** editor. The **Evaluation Method** editor is used to select the evaluation method and the respective pass/fail criteria that you want to use when evaluating a generator. See ["Edit Evaluation Method" on page 47](#).
- Click **Assign Engine Data** to open the **Engine Data Measurements** editor. The **Engine Data Measurements** editor is used to define engine data values and other custom data values for generators. Defining engine data measurements is optional. See ["Edit Engine Data" on page 49](#).
- Click **Assign Engine Data** to open the **Assign Engine Data Measurement** editor. The **Engine Data Measurement** editor is used to associate engine data values with specific generator measurements. For information about this activity, see ["Assign Engine Data" on page 49](#).

### Exhaust Gas Temperature Data

- (Optional) If exhaust gas data is not being captured, you do not need to select and complete these values. To capture exhaust data, check the box and complete these fields:
  - **Source** - Select a source name. The source represents the device that records the exhaust gas temperature of the generator.
  - **Single Exhaust** or **Dual Exhaust** - Select one of these options to indicate whether the exhaust gas temperature is measured for a single exhaust or a dual exhaust generator.
  - **Measurement** - Select the exhaust gas temperature measurement.
  - **Unit** - Select either F (for Fahrenheit) or C (for Celsius) for the temperature unit of measurement.
  - Click **Edit Evaluation Method** to open the **Evaluation Method** editor. The **Evaluation Method** editor is used to select the evaluation method and the respective pass/fail criteria that you want to use when evaluating a generator. See ["Edit Evaluation Method" on page 47](#).
  - Click **Assign Engine Data** to open the **Engine Data Measurements** editor. The **Engine Data Measurements** editor is used to define engine data values and other custom data values for generators. Defining engine data measurements is optional. See ["Edit Engine Data" on page 49](#).
  - Click **Assign Engine Data** to open the **Assign Engine Data Measurement** editor. The **Engine Data Measurement** editor is used to associate engine data values with specific generator measurements. For information about this activity, see ["Assign Engine Data" on page 49](#).

### Status Measurements

- Use this area to configure the states used to record the status of a generator. A generator can be in one of three states: **Starting**, **Running**, and **Stopped**. When a generator is in one of the states, the active value is stored in the measurement. The states appear in the **Events Summary** section of the EPSS Test Report.
  - **Source** - Select a source name. The source represents the ION device that records the status of a generator.
  - **Starting** - (Optional) This state indicates that the generator is starting. Select the check box, select the measurement that provides the starting state input, and enter the active value for the measurement. If this setting does not apply to your installation, do not select the check box.
  - **Running** - This state indicates that the generator is running. Select a measurement that provides the running state input, and enter the active value for the measurement.
  - **Stopped** - This state indicates that the generator has stopped. Select a measurement that provides the stopped state input, and enter the active value for the measurement.

Two stop signals could be sent from the generator controller – the initial stop signal, which is followed by 3-5 minute cooling period, and the final stop signal after the cooling period is complete. If the generator has two stop signals, be sure to use the measurement for the first stop signal before the generator goes into the cooling mode. Do not use the stop signal after the cooling period.

The active value for the measurements can be any value you choose.

For example, assume that the system has been configured with measurements of `GENStarting`, `GENRunning`, and `GENStopped`. You assign these measurements to the **Starting**, **Running**, and **Stopped** states respectively and enter 1 as the Active Value for each.

- When the generator starts, the active value for `GENStarting` becomes 1, and **Starting** is the state for the generator.
- When the generator is running, the active value for `GENRunning` becomes 1, and **Running** is the state for the generator.
- When the generator stops, the active value for `GENStopped` becomes 1, and **Stopped** is the state for the generator.

When an EPSS Test Report is generated, the states for the generator, and the time when they occurred, are included in the **Events Summary** section of the report. See Power Monitoring Expert Web help for information about this report.

#### **Additional notes about the Status Measurements:**

If there is only one measurement to indicate that the generator is either running or stopped, then you select that measurement for both the **Running** and **Stopped** states, and assign a different active value for each. For example, if the measurement used to indicate whether a generator is running or not is `GenRunningStopped`, define the states like this:

For the **Running** state:

1. Select `GenRunningStopped` as the measurement.
2. Set the Active Value to 1.

When the generator is running, the active value for `GenRunningStopped` is 1, and **Running** is the state for the generator.

For the **Stopped** state:

1. Select `GenRunningStopped` as the status measurement.
2. Set the Active Value to 0.

When the generator is stopped, the active value for `GenRunningStopped` is 0, and **Stopped** is the state for the generator.

- **Monitor for EPS Available** - (Optional) This state indicates that the emergency backup source is available.

Select the check box, select the measurement that provides the available state input, and then enter the active value for the measurement. If this setting does not apply to your installation, do not select the check box.

Recommended state is 0 or 1.

- **Required Time (Seconds)** - Enter a value in seconds. The Required Time value specifies the amount of time required to be considered a pass.

If you click **Apply** at this point, you can run the EPSS Test Report for date ranges, but not for a run history.

### Battery Waveforms

- (Optional) Use this area to if you want to configure and generate the Generator Battery Health Report. To enable the report, check the box and complete these fields:
  - **Source** - Select a source name that is performing the waveform capture. This option is only available for ION7550 and ION7650 meters.
  - **Measurement** - Select the measurement recording the battery waveform. For a typical configuration, this is the V4 waveform.

3. Click **Apply** to save the changes and remain on the tab.
4. Repeat these steps to define other generators.
5. If you are defining several similar generators, use the **Clone** button. See "[Clone Generator Properties](#)" on page 46.

## Clone Generator Properties

You can use the clone feature to copy the properties of an existing generator entity and use those properties as the baseline for multiple generators. The clone feature can help you define several similar generators quickly.

1. On the **Generators** tab, select the generator you want to use as the baseline for another generator.
2. Click **Clone** to create a new generator based on a selected entity. Many fields are copied from the selected generator. The fields which are not copied have an information icon to indicate where you need to enter data, as follows:
  - **Name** - Enter a unique name to identify the generator.
  - **Electrical Data - Source** - Select a source name from the dropdown list. The source represents the device that records the electrical data from the generator.
  - **Status Measurements - Source** - Select a source name. The source represents the metering device that records the status of a generator.

For information about other generator properties, see "[Edit Generator Properties](#)" on page 43.

## Edit Evaluation Method

The **Evaluation Method** editor is used to select the evaluation method and the respective pass/fail criteria that you want to use when evaluating a generator.

1. Click **Edit Evaluation Method** to open the **Edit Evaluation Method** editor.

**Edit Evaluation Method for Main Gen 1**

Evaluation Method: Load Bank ✓ Number of Stages: 3

Stage One Criteria

Suggested Load %: 25 Run Duration (Minutes): 30

Stage Two Criteria

Suggested Load %: 50 Run Duration (Minutes): 30

Stage Three Criteria

Suggested Load %: 75 Run Duration (Minutes): 60

**Stage One:**  
Electrical Load must be at least 25% of the Nameplate Rating for at least 30 minutes.

**Stage Two:**  
Electrical Load must be at least 50% of the Nameplate Rating for at least 30 minutes.

**Stage Three:**  
Electrical Load must be at least 75% of the Nameplate Rating for at least 60 minutes.

OK Cancel

2. Complete the following to set up evaluation criteria for a generator:
  - **Evaluation Method** - Select an evaluation method. For **Load Bank**, you can select from one to three stages to include in the evaluation. If you select **Load Bank**, the **Generator Load Summary** section of the EPSS Test Report shows the details of the selected stages of the load bank test. The stages are represented on the graph. The table below describes the evaluation methods.
  - **Number of Stages** - Select the number of stages for the evaluation if you selected **Load Bank**.
  - **Suggested Load %** or **Minimum Exhaust Gas Temperature** - Depending on the evaluation method that you selected, enter a numerical value for the percentage or for the temperature.
  - **Run Duration (Minutes)** - Enter the minimum number of minutes that the test needs to run for evaluation purposes.
3. Click **OK** to save the evaluation criteria and return to the **Generators** tab.

The evaluation methods and their respective pass/fail criteria are listed in the following table. **Load** is the default evaluation method.

<b>Evaluation Method</b>	<b>Pass/Fail Criteria</b>
Load	The generator must run at an electrical load % that is equal to or greater than the manufacturer's suggested electrical load % for the run duration.
Engine Temperature	The generator must run at an engine temperature that is less than or equal to the engine temperature for the duration.
Exhaust Gas Temperature	The generator must run at an exhaust gas temperature that is equal to or greater than the manufacturer's suggested exhaust gas temperature for the run duration.
Load Bank	The generator must pass the stages selected for the electrical load bank test. If more than one stage is selected, the generator must pass each stage consecutively.
Load OR Engine Temperature	The generator must pass either the electrical load or the engine temperature test.
Load OR Exhaust Gas Temperature	The generator must pass either the electrical load or the exhaust gas test.
Load AND Exhaust Gas Temperature	The generator must pass both the electrical load and the exhaust gas test.
Load AND Engine Temperature	The generator must pass both the electrical load and the engine temperature test.
Load OR Engine Temperature OR Exhaust Gas Temperature	The generator must pass either the electrical load or the exhaust gas test or the exhaust gas test.
Load OR Engine Temperature AND Exhaust Gas Temperature	The generator must pass either the electrical load or the engine temperature test and the exhaust gas temperature test.
Load AND Engine Temperature OR Exhaust Gas Temperature	The generator must pass both the electrical load and the engine temperature test OR the exhaust gas temperature test.
Load AND Engine Temperature AND Exhaust Gas Temperature	The generator must pass both the electrical load and the engine temperature test and the exhaust gas temperature test.

You can edit the test criteria for a test method by selecting the test name and then updating its criteria. The following table shows the default test criteria for each evaluation method. Confirm that these values meet the regulations mandated by local jurisdictions, or meet the minimum values recommended by the manufacturer, and update them if necessary.

<b>Test Name</b>	<b>Stage</b>	<b>Minimum</b>	<b>Run Duration</b>
Load	1	30 %	30 minutes
Engine Temperature	1	140 F	30 minutes
Exhaust Gas Temperature	1	900 F	30 minutes
Load Bank	1	25 %	30 minutes
Load Bank	2	50 %	30 minutes
Load Bank	3	75 %	60 minutes

## Edit Engine Data

The **Engine Data Measurements** editor is used to define engine data values and other custom data values for generators. The items being measured, typically analog data, can differ from generator to generator. Battery voltage and coolant temperature are two common measurements.

If you want to use the Smart Device Data Collector to log generator data, add the engine data values you need. These values can also be reported on the Trend Report, Tabular Report, EPSS Test Report, and dashboard gadgets.

Follow these steps to add engine data values and other custom data values.

1. Click **Edit Engine Data** to open the **Edit Engine Data Measurements** editor.

Modified	Name	Unit
	Coolant temperature	F
+	Battery voltage	V

Name:  Units:

2. Click **New** to enable the input fields.
3. Complete the following to define new data values:
  - **Name** - Enter a name for the data value.
  - **Units** - Enter a unit of measure for the data value.
4. Click **OK** to save the new data value and return to the **Generators** tab.

Next, assign these data values to generator measurements. See ["Assign Engine Data" on page 49](#) for instructions.

## Assign Engine Data

The **Engine Data Measurement** editor is used to associate engine data values with specific generator measurements. See ["Edit Engine Data" on page 49](#) for instructions to define custom engine data values.

1. Click **Assign Engine Data** to open the **Assign Engine Data Measurement** editor.

Modified	Engine Data Measurement	Source	Measurement
+	Coolant temperature	EPSS.GEN1	Coolant Temperature
!	Battery voltage	EPSS.GEN1	

Engine Data Measurement:   Data Collector

Source:

Measurement:

2. Click **New**.
3. Complete these fields to associate a data value with a specific measurement:
  - **Engine Data Measurement** - Select the data value. The dropdown list contains all of the data values that were configured on the Edit Engine Data Measurements screen.
  - **Source** - Select the device name that records the generator data.
  - **Measurement** - Select the measurement for the data value.
  - **Data Collector** - Check this option to enable users to enter measurement data through the Smart Device Data Collector web tool. See ["Smart Device Data Collector" on page 77](#). This data can also be included in the EPSS Test Report.
4. Click **OK** to save your changes and return to the **Generators** tab.

## Define Transfer Switches for EPSS

Use the **Transfer Switches** tab to configure the automatic transfer switch entities in the system. Complete this tab when you are configuring the EPSS Test Report.

Modified	Name	Description	Source	Priority Level	Required Transfer Time
	Main TS 1	Test Auto Transfer Switch	MAIN.TS_1	Critical	10
	Main TS 10	Test Auto Transfer Switch	MAIN.TS_10	Critical	10
	Main TS 10A	Test Auto Transfer Switch	MAIN.TS_10A	Critical	10
	Main TS 10B	Test Auto Transfer Switch	MAIN.TS_10B	Critical	10
	Main TS 11	Test Auto Transfer Switch	MAIN.TS_11	Critical	10
	Main TS 11A	Test Auto Transfer Switch	MAIN.TS_11A	Critical	10
	Main TS 12	Test Auto Transfer Switch	MAIN.TS_12	Critical	10
	Main TS 12A	Test Auto Transfer Switch	MAIN.TS_12A	Critical	10
	Main TS 12B	Test Auto Transfer Switch	MAIN.TS_12B	Critical	10

Edit Transfer Switch: Main TS 1

Name: Main TS 1

Description: Test Auto Transfer Switch

Priority Level: Critical

Required Transfer Time: 10 seconds

Status Measurements

Source: MAIN.TS\_1  Data Collector

Normal: A-S2 Status Active Value: 1

Test: A-S4 Status Active Value: 1

Emergency: A-S1 Status Active Value: 1

Monitor for Power Outage? Active Value: 1

No Measurement selected.

Rating: Unit:

Source: Unassigned Measurement: Unassigned

OK Cancel Apply

You can perform the following actions on this tab:

- Click **New** to create a transfer switch entry and to define specific values for it. See ["Edit Transfer Switch Properties"](#) on page 52 for instructions.
- Click **Clone** to define a new transfer switch that is similar to an existing entry. The system copies many details of the existing device into the new entry. You can then enter the unique details of the new device. If you need to define several devices that are similar, this feature can help you define them quickly. For more information, see ["Clone Transfer Switches"](#) on page 53.
- Click **Delete** to remove records from the system.
- Click **Revert** (before you click **Apply** or **OK**) if you make changes to a record and want to revert to your initial settings.

- Click **Edit Priority Levels** to open the **Priority Levels** editor. The **Edit Priority Levels** editor is used to select at least one priority level that you want to apply to your transfer switches. See "[Edit Priority Levels](#)" on page 54 for instructions.

## Edit Transfer Switch Properties

The **Edit Transfer Switch** area on the tab is used to create a transfer switch entry and to define specific values for it.

1. Click **New** to create a transfer switch entity.
2. Complete the following to define a transfer switch.
  - **Name** - Enter a unique name to identify the transfer switch.
  - **Description** - optional. Enter other information that you want to use to identify the transfer switch.
  - **Load Data** - Check this box if you want to generate the Equipment Capacity Management Report for the ATS.
    - **Source** - Select a meter source that is recording electrical data from the ATS.
    - **Measurement** - Select the electrical measurement item you want to track when the report is generated, such as Current Phase Average.
    - **Rating** - Enter the rating value for the measurement, such as 400.
    - **Unit** - Enter the unit of measurement, such as A.
  - **Priority Level** - Select a priority level from the dropdown list. You need to assign a priority level to each transfer switch. After you assign a priority level, the required transfer time for it appears under the dropdown list.
  - **Status Measurements** - Configure the states used to record the status of the ATS. When a transfer switch is in one of the states, the active value is stored in the measurement. The states appear in the **Events Summary** section of the EPSS Test Report.
    - **Data Collector** - Check this option to enable users to enter measurement data through the Smart Device Data Collector web tool. See "[Smart Device Data Collector](#)" on page 77. This data can also be included in the EPSS Test Report.
    - **Source** - Select a source name. The source represents the device that records the status of a transfer switch.
    - **Normal** - The ATS is in the Normal position and power is supplied to the load from the utility. Select the measurement that provides the input indicating that the ATS is in the **Normal** state, and then enter the active value for the measurement.
    - **Test** - The ATS is in the Test mode. Select the measurement that provides the input indicating that the ATS is in the **Test** state, and then enter the active value for the measurement.

- **Emergency** - The ATS is in the Emergency position and power is supplied to the load from the generator. Select the measurement that provides the input indicating that the ATS is in the **Emergency** state, and then enter the active value for the measurement.
- **Monitor for Power Outage** - If you are monitoring utility power, select this option. Select the measurement that indicates a power outage occurred and enter the **Active Value** for the measurement.

The active value for the measurements can be any value you choose.

For example, assume that the system has measurements called EPSS\_Norm, EPSS\_Test, EPSS\_Emerg, and EPSS\_Util. You assign these measurements to the **Normal**, **Test**, **Emergency**, and **Power Outage** states and enter 1 as the active value for each.

When the ATS is in the Normal position, the active value for EPSS\_Norm is 1, and **Normal** is the state for the ATS. When the ATS is set to the Test mode, the active value for EPSS\_Test is 1, and **Test** is the state for the ATS. When the ATS is in the Emergency position, the active value for EPSS\_Emerg is 1, and **Emergency** is the state for the ATS. If a power outage occurs, the active value for EPSS\_Util is 1, and **Power Outage** is the state for the ATS.

In the EPSS Test Report, the states for the ATS and the time when they occurred are included in the Events Summary section.

In the Automatic Transfer Switch Summary section of the report, the states are used to derive the Transfer Time and In Emergency time:

- **Transfer Time** - The duration (in seconds) to switch to the **Emergency** state. For Test mode, the Transfer Time is the time to switch from the **Normal** state to the **Emergency** state once the test signal has been received. When an actual power outage occurs, the Transfer Time is the time to switch from the **Normal** state to the **Emergency** state once the power outage signal has been received.
- **In Emergency** - The duration (in hours, minutes, and seconds) the ATS receives power from the generators. This is the time between the **Emergency** state and the **Normal** state.

3. Click **Apply** to save the changes and remain on the tab.
4. Repeat these steps to define other transfer switches.
5. If you are defining several similar transfer switches, use the **Clone** button. See "[Clone Transfer Switches](#)" on page 53.

## Clone Transfer Switches

You can use the clone feature to copy the properties of an existing transfer switch entity and use those properties as the baseline for multiple transfer switches. The clone feature can help you define several similar transfer switches quickly.

1. On the **Transfer Switches** tab, select the transfer switch you want to use as the baseline for another transfer switch.
2. Click **Clone** to create a new transfer switch based on a selected entity. Many fields are copied from the selected transfer switch. The fields which are not copied have an information icon to indicate where you need to enter data, as follows:
  - **Name** - Enter a unique name to identify the generator.

- **Status Measurements - Source** - Select a source name.

For information about other transfer switch properties, see ["Edit Priority Levels" on page 54](#).

3. Click **Apply** to save the new transfer switch entity.

## Edit Priority Levels

The **Edit Priority Levels** editor is used to select at least one priority level that you want to apply to your transfer switches.

1. Click **Edit Priority Levels** to open the **Edit Priority Levels** editor.

Modified	Name	Required Transfer Time	Power Outage Enabled	Color
	Critical	10	<input checked="" type="checkbox"/>	Red
	Equipment	30	<input type="checkbox"/>	Blue
	Life Safety	10	<input checked="" type="checkbox"/>	Yellow

Name:  Required Transfer Time (Seconds):

Evaluate this Priority Level when reporting on Power Outages ■ 255, 0, 0

OK Cancel

2. Click **New** to add a priority level.
3. Complete the following to define priority levels:
  - **Name** - Enter a unique name to identify the priority level.
  - **Required Transfer Time (Seconds)** - Enter the transfer time in seconds. This value indicates the maximum acceptable time for the ATS to switch from the **Test** state to the **Emergency** state.
  - **Evaluate this Priority Level when reporting on Power Outages** - Select this check box to include a priority level in the pass or fail grading. Clear the check box to exclude the priority level from grading. By excluding a priority level, you can exclude non-critical switches from evaluation.

For example, if a transfer switch has a priority level of Life Safety and it must be graded as a result of a power outage, then select this check box. Conversely, if a transfer switch has a priority level of Equipment, this transfer switch may not have to be graded as a result of a power outage. In this case, clear the check box.

- **Color Picker** - Select the color that the priority level detail will appear in the test report.

Default priority levels are shown in the following table. You can change any of these to a priority level scheme of your choice.

Name	Required Transfer Time	Power Outage Enabled
Life Safety	10	True
Critical	10	True
Equipment	30	False

- Click **OK** to save the priority level and return to the **Transfer Switch** tab.

## Define Equipment for EPSS

Use the **Equipment** tab to create a logical device with a source measurement and rating. You can add these logical devices to device groups for reporting. Complete this tab when you are configuring reports.

The screenshot shows the 'Generator Performance Configuration Tool - Power Monitoring Expert for Healthcare' interface. The 'Equipment' tab is active, displaying a table of equipment records. Below the table, the 'Edit Equipment: Equip1' dialog is open, allowing for configuration of the selected equipment.

Modified	Name	Rating	Unit	Description
*	Equip1	100	kW	
	Equip2	1500	kW	Test Auto
	IONE7650_Meter1	2000	kW	Test Auto
	IONE7650_Meter2	2600	kW	Test Auto
	laurel_North.S1	1000	kW	Test Auto

**Edit Equipment: Equip1**

Name: Equip1

Description:

Load Data Source: EPSS.G1

Measurement: Active Energy Delivered Phase A

Rating: 100 Unit: kW

You can perform the following actions on this tab:

- Click **New** to enter new record for a device. See ["Edit Equipment Sources" on page 56](#) for instructions to define the devices.
- Click **Clone** to copy an existing record and make minor changes. The system copies many details of the existing device into the new entry. You can then enter the unique details of the new device. If you need to define several devices that are similar, this feature can help you define them quickly.
- Click **Delete** to remove records from the system.
- Click **Revert** (before you click **Apply** or **OK**) if you make changes to a record and want to revert to your initial settings.

## Edit Equipment Sources

The **Equipment** tab displays the equipment load sources and measurements defined in the system.

1. Click **New** to create a record.
2. Complete these fields:
  - **Name** - Enter a unique name to identify the record.
  - **Description** - Enter additional information about the device. Optional.
  - **Source** - Select the load source for the device.
  - **Measurement** - Select the measurement for the device.
  - **Rating** - Enter the maximum rated load for the device.
  - **Unit** - Enter the unit of the measurement.
3. Click **Apply** to save the record and remain on the tab.
4. Repeat these steps to enter additional devices.

## Define Groups for EPSS

A performance group is a combination of generators, transfer switches, and other equipment for reporting and generating Vista diagrams. Complete the **Groups** tab when you are configuring reports.

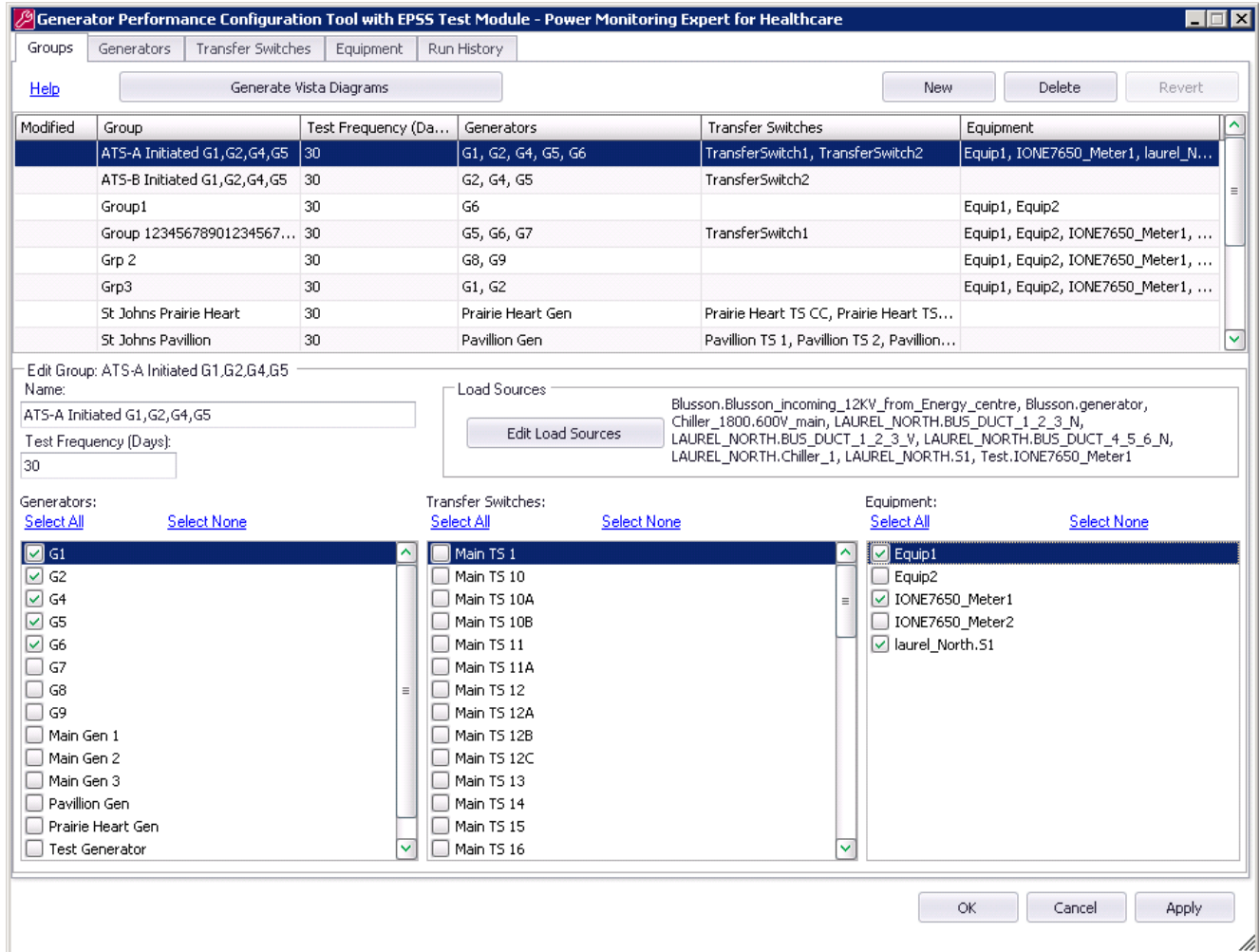

You can perform the following actions on this tab:

- Click **New** to create a new group for generating reports and Vista diagrams. A group can contain any device that has been configured on the other tabs. See ["Edit Groups" on page 58](#) for instructions to define the groups.
- Click **Delete** to remove records from the system.
- Click **Revert** (before you click **Apply** or **OK**) if you make changes to a record and want to revert to your initial settings.
- Click the **Edit Load Sources** to associate a group with the electrical loads that the group of generators must carry in a power outage. See ["Edit Group Load Sources" on page 59](#) for instructions.
- Click **Generate Vista Diagrams** to generate the frameworks for the EPSS groups. You can select which groups to include in the diagrams. See ["Generate EPSS Vista Diagrams" on page 63](#) for instructions.

## Edit Groups

The **Groups** tab displays the device groups defined in the system. The generators, and transfer switches, and other equipment must be defined on their respective tabs before you can add them to a group.

1. Click **New** to create a group.
2. Complete the following to define the values for a group:
  - **Name** - Enter a unique name to identify the group.
  - **Test Frequency** - Select the frequency, in days, that the group should be tested. Refer to local regulations for an appropriate value.
  - **Generators** - Select the generators to include in the group.
  - **Equipment** - Select the equipment to include in the group.
  - **Transfer Switches** - Select transfer switches to include in the group.

The **Select All** and **Select None** options let you work easily with large numbers of sources by selecting all check boxes or clearing all check boxes at the same time.
3. Click **Apply** to save the group and remain on the tab.
4. Repeat these steps to create other groups.

## Edit Group Priority Levels

The following reports use priority levels:

- Generator Capacity Report – Priority level values are required to accurately display the colors indicated in the priority levels.
- EPSS Test Report – Priority level values are required for the ATSS in the system to PASS or FAIL an ATS based on the required transfer time of the priority level.

Default priority levels are setup as default.

The **Edit Priority Levels** editor is used to select at least one priority level that you want to apply to the equipment groups. The default priority level names and transfer times are:

- Critical - 10 sec
- Equipment - 30 sec
- Life Safety - 10 sec

You can change any of these names and transfer times and add new priority levels as necessary.

1. Click **Edit Priority Levels**. The **Priority Levels** screen appears.

Modified	Name	Required Transfer Time	Color
	Critical	10	Red
	Equipment	30	Blue
	Life Safety	10	Orange

Name:

Required Transfer Time (Seconds):

255, 0, 0

2. Click **New** to add a priority level.
3. Complete the following to define priority levels:
  - **Name** - Enter a unique name to identify the priority level.
  - **Required Transfer Time (Seconds)** - Enter the transfer time in seconds. This time indicates the maximum acceptable time it takes the equipment to move from the **Test** state to the **Emergency** state.
  - **Color** - Click the color box to select a color for the priority level. This color appears on the Generator Capacity Report summary page, where the generator loads are compared.
4. Click **OK** to save the priority level and return to the **Groups** tab.

## Edit Group Load Sources

On the **Select Load Sources** screen, you can associate a group with the various electrical loads that the group of generators must carry during a power outage.

Be sure to define the priority levels for the system before you configure load sources. See ["Edit Priority Levels" on page 54](#) for instructions.

1. Click **Edit Load Sources**. The **Edit Load Sources** screen appears.

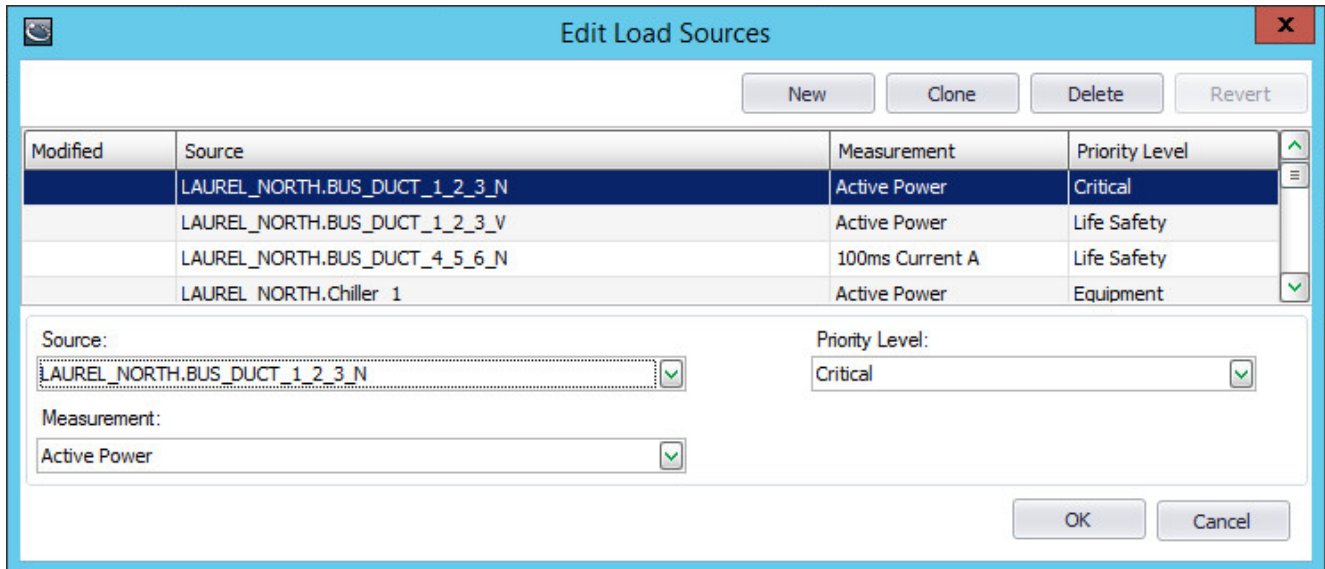

2. Click **New** to add a load source.
3. Complete these fields:
  - **Source** - Select the measurement source.
  - **Measurement** - Select the measurement to monitor.
  - **Priority Level** - Select the priority level to assign to the load source.
4. Click **OK** to save the new load source and return to the **Groups** tab.

You can use the **Clone** button to associate a group with several sources where the load is logged against the same measurement. The cloned group contains the same measurement and priority level as the original.

## View Run History for EPSS

Use the **Run History** tab to view or modify run activities that represent the Test, Load Shedding, and Power Outage activities that have occurred in the system. The history indicates when components of the EPSS have become active, such as when a generator was running or when a transfer switch entered test or emergency status. The runs stored in history can be used as input for reports and dashboards in Power Monitoring Expert.

Because the system stores the history of these activities, you can generate useful reports about the equipment operation. The reports can identify when the system was active, why the system was active, and what devices were active.

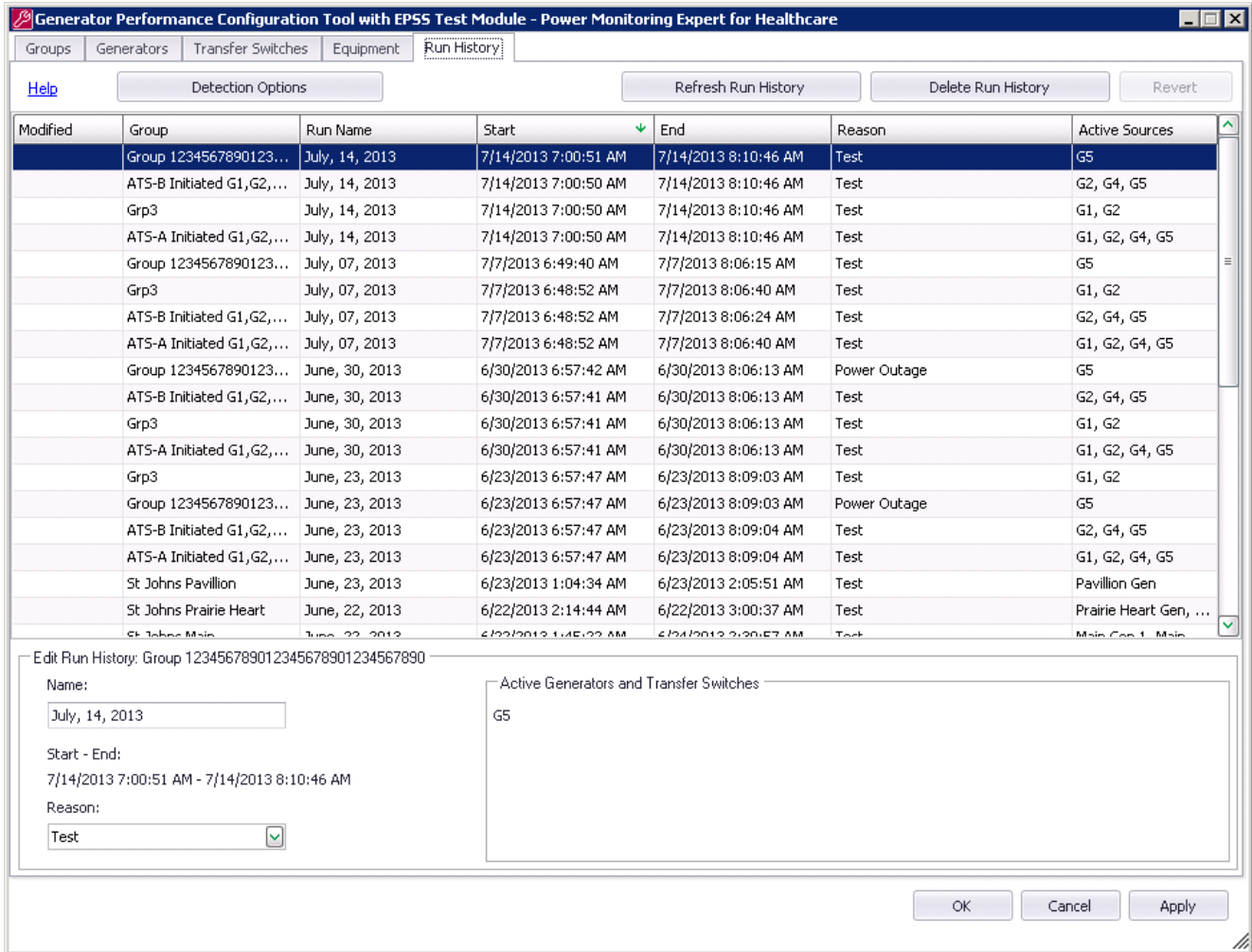

The first time the history records are generated on the **Run History** tab, the system may take a long time depending on the amount of history present in the system. When changes occur in the EPSS configuration, the run history must be generated again.

For example if you remove a generator from a group, the run history for that group needs to be rebuilt because that generator may have been the reason for the detection of a run. Now that the generator is not part of the group, the system needs to build the run history again to have accurate data.

You can perform the following actions on this tab:

- Click **Detection Options** to modify the criteria of a run event that will cause it to appear on this tab. See ["Modify Run Detection Options" on page 62](#).
- Click **Refresh Run History** to update the tab with the latest run events that have occurred in the system.
- Click **Delete Run History** to remove all run event records from the tab.
- Modify the name and run reason for a run event. See ["Modify Run Details" on page 62](#).

## Modify Run Detection Options

The run detection options can be defined to help guard against bad data in the system. To record actual run activities, you can set the parameters so the system only records runs that fall within the criteria.

The minimum run length value is present to prevent false positives, which may occur during commissioning when the states of the generators and transfers switches are changing quickly and seemingly at random. This may be due to signals being recorded that really do not reflect actual generator or transfer switch activity.

You can set the maximum run length to eliminate "hanging" runs. A hanging run occurs when the stop signal for a generator is not recorded properly. As a result, every time during the test it records a running signal but there is no way for the system to know when it stops. If the system does not see a stop signal, it sets the end of the run to be the start of the run plus the maximum run duration. Therefore you cannot determine how long the generator was actually running.

Complete the following steps to define the run criteria for the system to store runs in history.

1. Click **Detection Options**. The **Run Detection Options** screen appears.

2. Change the values in the minimum and maximum fields.
3. Click **OK** to save the changes and return to the **Runs** tab.
4. Click **Refresh** to update the tab with the run events that match the new detection criteria.

## Modify Run Details

The system defines run data, such as name, start time, end time, reason, and active sources automatically. You can change the name of the run event and the reason for the run.

- The default run name is the start date of the run, such as `June 12 2011`. If a group has multiple runs on the same date, the subsequent runs have the same date with the run number appended, such as `June 12 2011 Run 2` and `June 12 2011 Run 3`.
- The system automatically detects the reason for the run. If the detected reason is incorrect, you can change the reason. For example, the reason appears as `Test`, but the run is actually `Load Shedding`.

Other details about the run event cannot be modified directly. If the sources for a run are not correct, you can exclude or include specific sources when generating a report based on this run.

1. Click the run record you want to modify. The run details appear below the grid.

2. In the **Name** field, change the suggested run name as necessary.
3. In the **Reason** list, select the correct reason for the run.
4. Click **OK** to save the changes for the run.

## Generate EPSS Vista Diagrams

After the generators, transfer switches, and device groups are configured, you can generate the Vista diagrams for the configured devices. The same information can be built manually in Vista, but the Generator Performance Configuration Tool with EPSS Test Module provides a way to build these diagrams automatically. Vista diagrams help provide you with real time insight into the system.

See ["Set up the Template Diagram" on page 63](#) and ["Generate EPSS Diagrams" on page 64](#) for instructions.

After the diagrams are generated, you can open them in Vista or Designer and optimize the designs. See ["Vista Diagram Examples" on page 65](#) for descriptions and examples of the generated diagrams.

EPSS Vista diagrams are useful to the customer so they can see real-time information about the status of the generators, transfer switches, and other components of the system. The diagrams can include the customer logo and a map of the customer's facility. The customer can view the diagrams in the Diagrams module of Power Monitoring Expert after the diagrams have been linked to the Diagrams module.

The system includes a template that you can use to set up certain parts of the diagrams before you generate them.

### Set up the Template Diagram

The template diagram allows you to produce a consistent structure for the generated diagrams. The template file is used as a basis for the dynamically generated EPSS diagrams. The template is a normal diagram file that the system uses to apply common elements to the generated diagrams.

With the template, you can apply linked-button elements to the generated diagrams, which will help you reduce the amount of time to configure the diagrams.

Follow these steps to set up the diagram template.

1. Open the Vista Diagrams application.
2. Open the `Epss_Template.dgm` file in the folder:  
    `...\config\diagrams\ud\EPSS\templates`
3. To the left side of the diagram, add the buttons with the appropriate links.
4. Do not link the EPSS button to any diagram, because you will already be on the EPSS pages when they are generated.
5. Save and close the template diagram.

When diagrams are being generated by the configuration tool, the template is read in and any objects on the diagram will be added to every diagram created by the tool.

**NOTE:** On the generated diagrams, the background image is dynamically created. The background does not come from the EPSS template diagram.

## Generate EPSS Diagrams

Before you generate the EPSS Vista diagrams, make sure all devices and groups are configured correctly. Save the changes you have made to the EPSS configuration.

1. Click the **Groups** tab.
2. Click **Generate Vista Diagrams**. The Vista Diagram Generation screen appears.

The screenshot shows the 'Vista Diagram Generation' dialog box. It includes the following fields and options:

- Output Path:** C:\Program Files (x86)\Schneider Electric\NON Enterprise\config\diagrams\ud\EP
- Diagram Width:** 1000 pixels
- Included EPSS Groups:**
  - St Johns Hospital - Complete
  - St Johns Main
  - St Johns Pavillion
  - St Johns Prarie Heart
- Transfer Switch Options:**
  - Normal Color:  Default Color
  - Emergency Color:  Default Color
  - Include Test Button on Transfer Switches
  - Include Links to EPSS Groups on Generators and ATS diagrams
- Include Facility Logo:** 
  - Facility Logo: C:\Users\config\diagrams\images\epss\se.png
  - Recommended Size: 185x55 px
- Generate Facility Map:** 
  - Facility Name: Facility Map
  - Facility Map: [Browse]
  - Recommended Width: 786 px

Buttons: Generate Vista Diagrams, Done

3. In the **Output Path** field, enter or select the folder where you want to store the diagrams.
4. (Optional) In the **Included EPSS Groups** box, select the device groups that you want to generate diagrams for. Uncheck any groups you do not want to generate.
5. (Optional) In the **Transfer Switch Options** box, select the colors you want to use for normal and emergency status.
6. (Optional) Check the **Include Test Button on Transfer Switches** option if you want to add a control object for each ATS on the diagrams. This object allows you to manually test the ATS from the diagram. The control must be manually linked using Vista once the diagrams have been created.
7. (Optional) Check the **Include Links to EPSS Groups...** option if you want the device diagrams to have a link to the EPSS Group diagram.
8. In the **Diagram Width** field, select the horizontal width in pixels of the diagrams.

9. Select **Facility Logo** and enter the image file if you want the diagrams to include the customer logo at the top-left of every diagram.
10. Select **Generate Facility Map** if you want to include a map with the diagrams. If you do this, you will be able to add the generator and transfer switch device locations to the map.
  - Enter the **Facility Name** to appear on the map.
  - Select the image file for the map.
11. Click **Generate Vista Diagrams** to generate and store the diagrams in the selected output folder.

Several diagrams will be created: the homepage that lists all EPSS groups, summary pages that list all generators and transfer switches, and the detail pages for each EPSS Group, Generator and ATS in the system.

You can open the diagrams in Vista and optimize the designs if necessary. Refer to *ION Reference* for information about configuring the modules in the diagram.

See the next section "[Vista Diagram Examples](#)" on page 65 for descriptions and examples of the generated diagrams.

## Vista Diagram Examples

When you generate the Vista diagrams, several diagrams are produced.

- **Home Page diagram** - One Home Page diagram is generated. This diagram contains a navigation bar that has links for the facility map, device group diagrams, and device diagrams.
- **Group diagrams** - For each group selected on the configuration screen, one group diagram is produced. This diagram contains an object for each generator or transfer switch in the group. A Online diagram for each device group is also generated and linked to the diagrams. You will need to manually configure the generated Online diagrams. Several default objects are included for assistance.
- **Device detail diagrams** - For each generator and transfer switch in a group, a diagram is generated. The device diagram includes status information for the device, including run status, test parameters, and real-time electrical data.
- **Facility Map** - This diagram is generated if the option was selected on the configuration screen. This diagram includes a moveable icon for each generator and transfer switch in all the selected device groups. On the map diagram, you can drag and drop the device icons to the map to represent the physical locations of those devices.

### Home Page Diagram

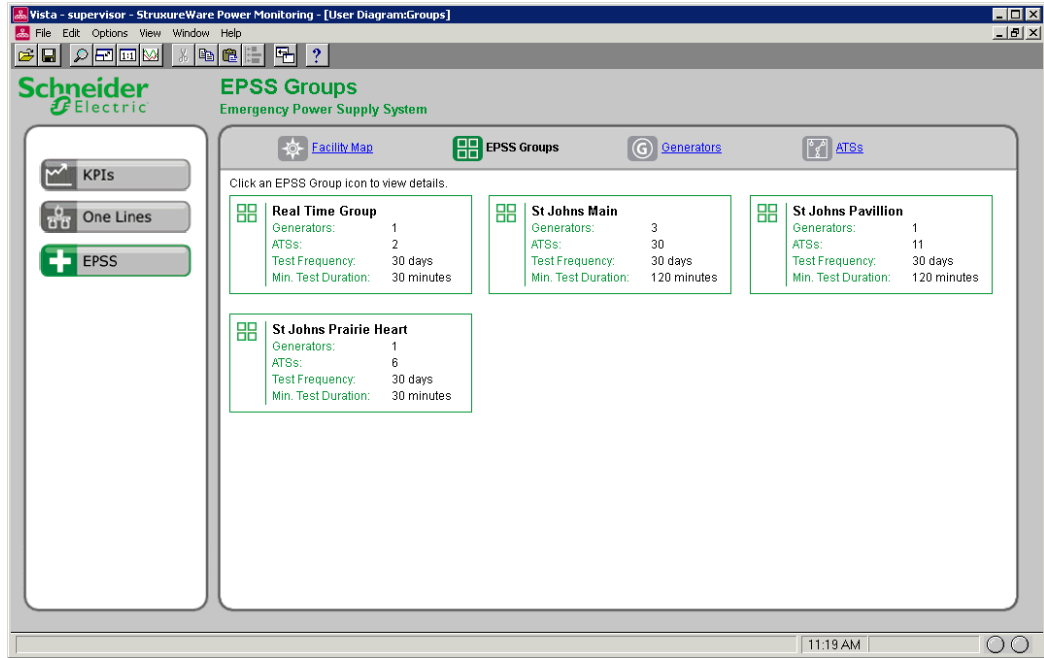

### EPSS Group Diagram

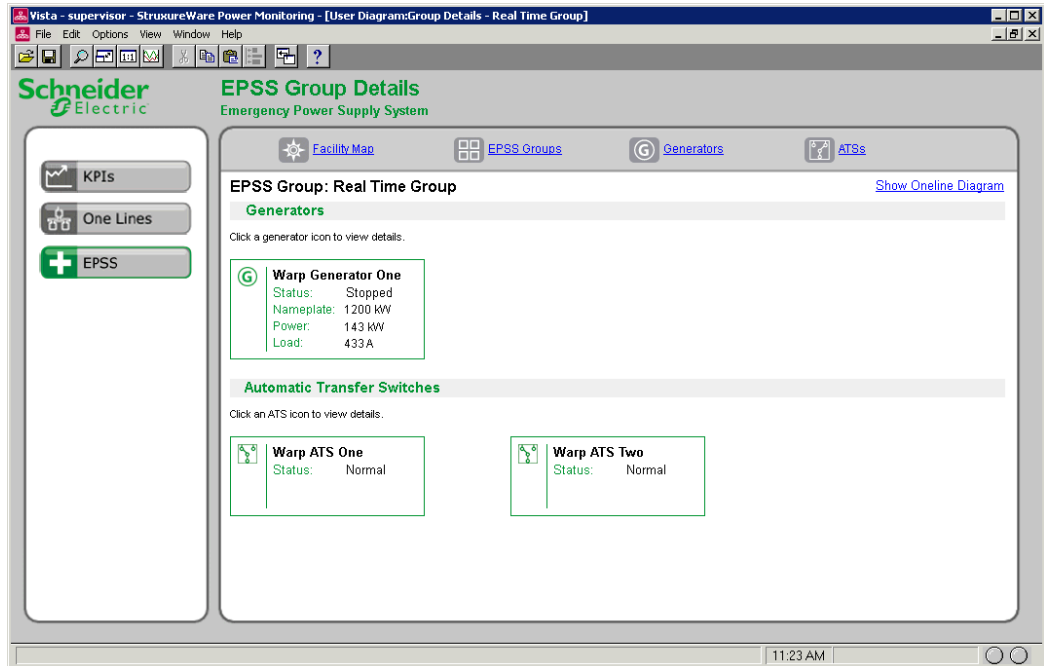

### Device Diagram

**Schneider Electric** Generator Details  
Emergency Power Supply System

EPSS Groups Generators ATSSs

**Generator: Prairie Heart Gen**

Status: **Running** Description: EPSS Group  
Load: kW TestAuto: [StJohns Prairie Heart](#)  
Nameplate Rating: 500 kW

**Test Parameters**

Test Evaluation Method: Load

Required Load: 30% (150 kW)  
Required Duration (Load): 30 minutes

Required Time to Emergency Power Source Available: 4 seconds

**Electrical Data**

Voltage  Current  Power

Other

### Facility Map

Vista - supervisor - StructureWare Power Monitoring - [User Diagram:Facility Map]

**Schneider Electric** Facility Map  
Emergency Power Supply System

Facility Map EPSS Groups Generators ATSSs

St Johns Prairie Heart

St Johns Pavilion

Medical Office Building  
1550 N. 115th St.

Medical Arts Building  
1530 N. 115th St.

St Johns Main

Real Time Group

After Hours, Please Use Side Entrance

North 120th Street

North 115th Street

Main Entrance

8:58 AM

## EPSS Test Report

The EPSS Test Report shows the run details and overall status for generators and transfer switches in the group. For example, the report shows the transfer time of the lead ATS and indicates whether the transfer time passes or does not pass the test requirements.

Use the Reports module in Web Applications to configure and generate the EPSS Test Report.

For more information on generating and managing reports, see the "Reports" section of the Web Applications help file.

## Report Prerequisites

In the Generator Performance Configuration Tool with EPSS Test Module, define the following tabs and fields in order to generate the report.

### Generators Tab

- **Name** - Enter a name for the generator entity.
- **Electrical Data** - Enter the measurement source, nameplate rating, and unit of measurement.
- **Status Measurements** - Enter the source of the status measurement and the start, run, and stop values. Configure the meters that provide these measurements.
- **Evaluation Method** - "Load" is default, but you can change this to accommodate customer requirements.

See ["Define Generators for EPSS" on page 42](#) for instructions on the above settings.

### Transfer Switches Tab

- **Name** - Enter a name for the ATS entity.
- **Status Measurements** - Select the source of the status measurement and the start, run, and stop values. Configure the meters that provide these measurements.
- **Priority Levels** - Default levels are provided, however you can change these levels to accommodate customer requirements.

See ["Define Transfer Switches for EPSS" on page 51](#) for instructions on the above settings.

### Groups Tab

- **Name** - Enter a name for the group entity.
- Select at least one entity from the **Generators**, **Transfer Switches**, or **Equipment** lists. The group can contain entities from each list combined.

See ["Define Groups for EPSS" on page 56](#) for instructions.

After these required items are defined, the report can be configured and generated, as described next.

## EPSS Test Report Example

The following images are examples of various sections of an EPSS Test Report in the order in which they occur.

### Title Page

The title page of the test report shows the title, company name, group, the name of the person preparing the report, and the test period.



### EPSS Report - May 2010

For

Park Royal Hospital

EPSS Main East

Prepared By

John Hancock

Test Period

5/3/2010 1:00:00 AM - 5/3/2010 3:00:00 AM (Server Local)

Generated on: 8/5/2010 1:02:33 PM

Page 1 of 2

### Sources

The **Sources** section shows the devices in the selected group.

#### Sources in Report Group: EPSS Main East

Source	Type	Description
ATS 01	Transfer Switch	This is a Life Safety Load ATS Device. Refer to EPSS operating procedure before testing this device.
ATS 02	Transfer Switch	This is a Critical Load ATS Device
ATS 03	Transfer Switch	This is a Non-Essential Load ATS Device
Gen 01	Generator	Cummins generator.

## Events Summary

The **Events Summary** section shows the status of the generators and transfer switches in the group.

### ATS and Generator Events Summary

Timestamp	Source Name	Status
5/3/2010 1:00:54.24 AM	ATS 01	Test
5/3/2010 1:00:54.54 AM	Gen 01	Start
5/3/2010 1:01:03.04 AM	Prairie Heart Gen	Emergency Power Source Available
5/3/2010 1:01:03.34 AM	ATS 01	Emergency
5/3/2010 1:01:24.24 AM	ATS 02	Test
5/3/2010 1:01:24.54 AM	ATS 02	Emergency
5/3/2010 1:01:46.31 AM	ATS 03	Test
5/3/2010 1:01:46.58 AM	ATS 03	Emergency
5/3/2010 1:59:18.90 AM	ATS 01	Normal
5/3/2010 1:59:19.90 AM	ATS 02	Normal
5/3/2010 1:59:29.89 AM	ATS 03	Normal
5/3/2010 2:06:21.63 AM	Gen 01	Stopped

## Automatic Transfer Switch Summary

The **Automatic Transfer Switch Summary** section includes sections for the **Lead ATS**, the **Time to Emergency Power Source Available**, and **All Automatic Transfer Switches** in the group.

### Automatic Transfer Switch Summary

#### Lead ATS

Lead ATS	Transfer Time	Required Transfer Time	Test Status
ATS 01	9.10 s	10 s	PASS

#### All Automatic Transfer Switches

Transfer Switch	Priority Level	Transfer Time	In Emergency (hh:mm:ss)
ATS 01	Life Safety	9.10 s	00:58:15
ATS 02	Critical	0.30 s	00:57:55
ATS 03	Non-Essential Equipment	0.27 s	00:57:43

### Generator Summary

The **Generator Summary** section shows the evaluation method is being used to determine the status of the generator being tested.

Generator Summary		
Generator: Gen 01		Nameplate: 1000 kW
Start Time: 5/3/2010 1:01:03 AM		Stop Time: 5/3/2010 2:06:21 AM
Evaluation Method	Overall Test Status	
Load and Exhaust Gas Temperature	PASS	
Test	Stage	Test Status
Load	One	PASS
Exhaust Gas Temperature	One	PASS

This example shows the Load Bank evaluation method was used on the generator.

Generator Summary		
Generator: Gen 01		Nameplate: 1000 kW
Start Time: 5/3/2010 1:01:03 AM		Stop Time: 5/3/2010 2:06:21 AM
Evaluation Method	Overall Test Status	
Load Bank	FAIL	
Test	Stage	Test Status
Load Bank	One	PASS
Load Bank	Two	PASS
Load Bank	Three	FAIL

### Generator Load Summary

The **Generator Load Summary** section shows a chart of the electrical load data for the generator being tested.

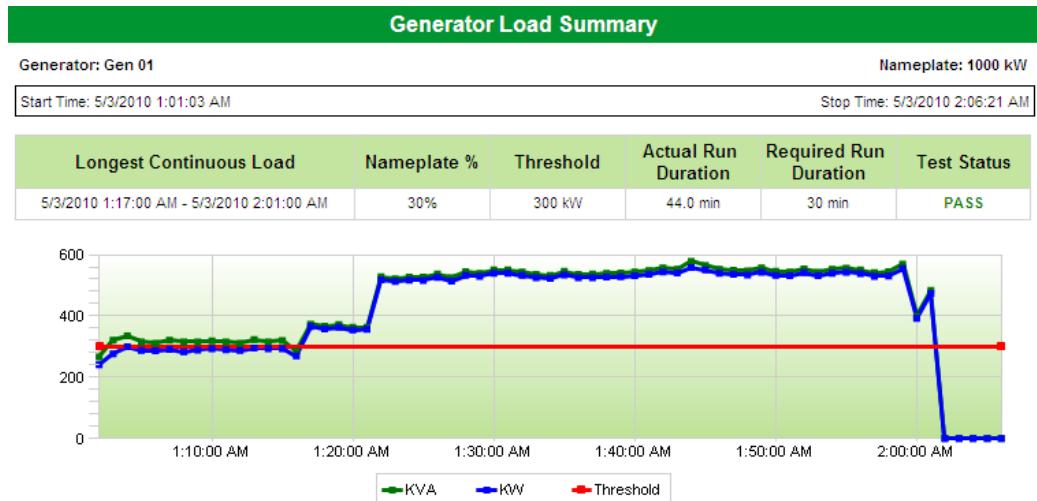

This is an example showing the Load Bank evaluation method was used.

**Generator Load Summary**

Generator: Gen 01 Nameplate: 1000 kW  
 Start Time: 5/3/2010 1:01:03 AM Stop Time: 5/3/2010 2:06:21 AM

Longest Continuous Load	Nameplate %	Threshold	Actual Run Duration	Required Run Duration	Test Status
5/3/2010 1:17:00 AM - 5/3/2010 1:27:00 AM	30%	300 kW	10.0 min	10 min	PASS
5/3/2010 1:27:00 AM - 5/3/2010 1:59:00 AM	50%	500 kW	32.0 min	10 min	PASS
No Load Found	70%	700 kW	0.0 min	10 min	FAIL

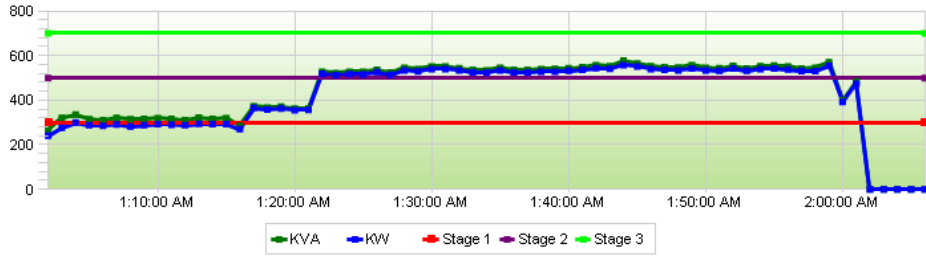

**Longest Continuous Load**

This section includes a table summarizing the minimum, average, and maximum electrical readings for the longest continuous load by load bank stages. The following images show data for each stage of the load bank test.

**Min, Avg, Max Readings for the Longest Continuous Load**

Generator: Gen 01 Nameplate: 1000 kW  
 Start Time: 5/3/2010 1:01:03 AM Stop Time: 5/3/2010 2:06:21 AM

Stage One		1:17:00 AM - 1:27:00 AM			
Measurement	Min	Avg	Max	Units	
Active Power	355.00	438.90	526.00	kW	
Apparent Power	363.00	447.90	537.00	kVA	
Current Phase A	449.00	559.60	674.00	A	
Current Phase B	421.00	519.70	624.00	A	
Current Phase C	434.00	531.20	632.00	A	
Voltage Phases AB	482.00	482.00	482.00	V	
Voltage Phases AN	278.00	278.00	278.00	V	

Stage Two				1:27:00 AM - 1:59:00 AM
Measurement	Min	Avg	Max	Units
Active Power	514.00	535.33	558.00	kW
Apparent Power	525.00	547.85	578.00	kVA
Current Phase A	659.00	688.82	729.00	A
Current Phase B	608.00	633.79	666.00	A
Current Phase C	619.00	646.12	679.00	A
Voltage Phases AB	482.00	482.00	482.00	V
Voltage Phases AN	278.00	278.06	279.00	V
Voltage Phases BC	482.00	482.03	483.00	V
Voltage Phases BN	278.00	278.03	279.00	V
Voltage Phases CA	482.00	482.03	483.00	V
Voltage Phases CN	278.00	278.03	279.00	V

Stage Three	
No Load Found	

### Generator Engine Temperature Summary

This example shows the Load AND Engine Temperature AND Exhaust Gas Temperature evaluation method used on the generator.

Generator Summary		
Generator: G1	Nameplate: 100 kW	
Start Time: 3/17/2015 7:00:50 AM	Stop Time: 3/17/2015 8:10:45 AM	
Evaluation Method	Overall Test Status	
Load AND Engine Temperature AND Exhaust Gas Temperature	PASS	
Test	Stage	Test Status
Load	One	PASS
Engine Temperature	One	PASS
Exhaust Gas Temperature	One	PASS

Generated on: 3/20/2015 12:35:35 PM Page 5 of 10

This section also includes a chart of the engine temperature readings for the longest continuous load and a table summarizing the minimum, average, and maximum engine temperature readings for the longest continuous load.

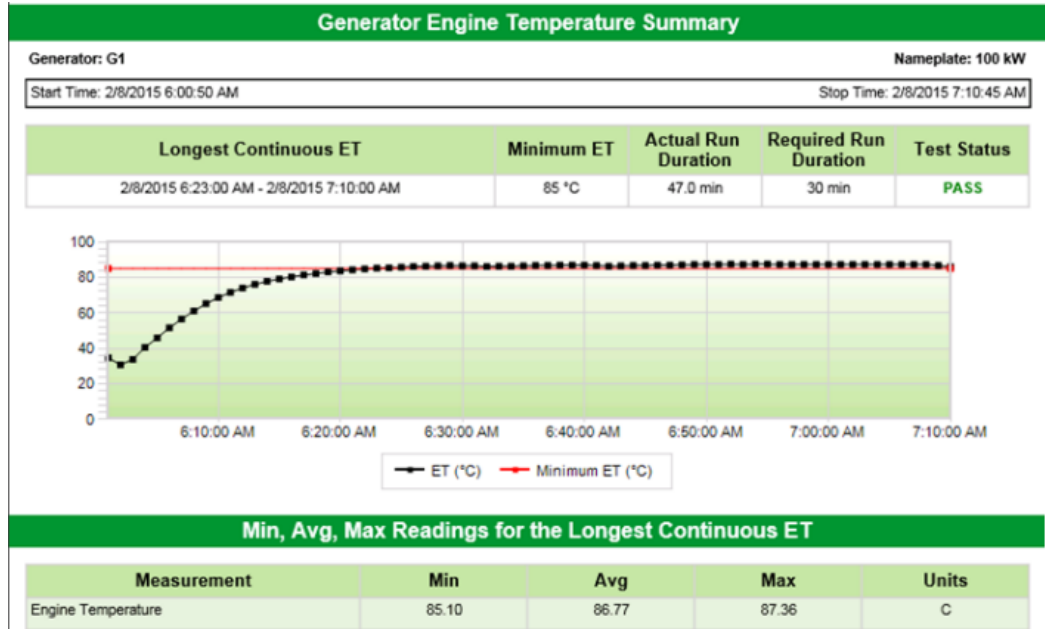

### Generator Engine Temperature Details

This section shows summarized engine temperature details by time intervals.

### Generator Engine Temperature Details

**Generator: G1** **Nameplate: 100 kW**

Start Time: 2/8/2015 6:00:50 AM Stop Time: 2/8/2015 7:10:45 AM

Timestamp	Engine Temperature °C
2/8/2015 6:01:00 AM	34.62
2/8/2015 6:02:00 AM	30.71
2/8/2015 6:03:00 AM	33.82
2/8/2015 6:04:00 AM	40.54
2/8/2015 6:05:00 AM	45.97
2/8/2015 6:06:00 AM	51.53
2/8/2015 6:07:00 AM	56.53
2/8/2015 6:08:00 AM	60.99
2/8/2015 6:09:00 AM	65.20
2/8/2015 6:10:00 AM	68.62
2/8/2015 6:11:00 AM	71.49
2/8/2015 6:12:00 AM	73.99
2/8/2015 6:13:00 AM	76.01

### Generator Exhaust Gas Summary

This section shows a chart of the exhaust gas temperature data.

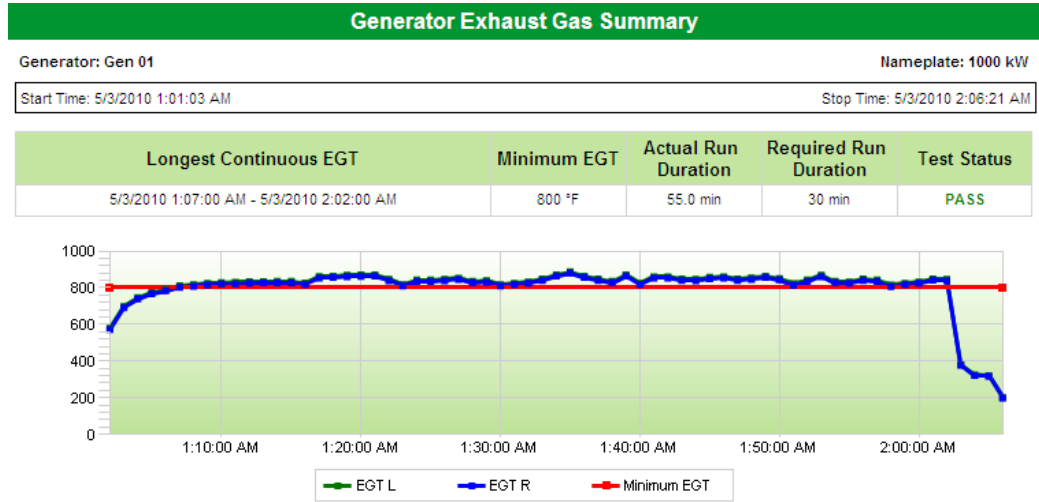

**Min, Avg, Max Readings for the Longest Continuous EGT**

Measurement	Min	Avg	Max	Units
Exhaust Gas Temperature Left	811.03	844.38	888.80	F
Exhaust Gas Temperature Right	803.00	836.02	880.00	F

### Generator Exhaust Gas Details

This section shows summarized exhaust gas temperature details by time intervals.

**Generator Exhaust Gas Details**

Generator: Gen 01		Nameplate: 1000 kW	
Start Time: 5/3/2010 1:01:03 AM		Stop Time: 5/3/2010 2:06:21 AM	

Timestamp	Exhaust Gas Temperature Left °F	Exhaust Gas Temperature Right °F
5/3/2010 1:02:00 AM	578.73	573.00
5/3/2010 1:03:00 AM	698.92	692.00
5/3/2010 1:04:00 AM	746.39	739.00
5/3/2010 1:05:00 AM	774.67	767.00
5/3/2010 1:06:00 AM	791.84	784.00
5/3/2010 1:07:00 AM	811.03	803.00
5/3/2010 1:08:00 AM	817.09	809.00
5/3/2010 1:09:00 AM	824.16	816.00

### Generator Electrical Details

This section shows summarized electrical details by time intervals.

Generator Electrical Details						
Generator: Gen 01				Nameplate: 1000 kW		
Start Time: 5/3/2010 1:01:03 AM				Stop Time: 5/3/2010 2:06:21 AM		
Timestamp	KW	KVA	Load %	VLLAvg	VLNAvg	Frequency
5/3/2010 1:02:00 AM	241.00	266.00	24.10	482.00	278.00	60.07
5/3/2010 1:03:00 AM	278.00	321.00	27.60	481.00	278.00	60.03
5/3/2010 1:04:00 AM	300.00	336.00	30.00	482.00	278.00	60.08
5/3/2010 1:05:00 AM	288.00	315.00	28.80	482.00	278.00	60.06
5/3/2010 1:06:00 AM	286.00	311.00	28.60	482.00	278.00	60.07
5/3/2010 1:07:00 AM	291.00	321.00	29.10	482.00	278.00	60.07
5/3/2010 1:08:00 AM	283.00	315.00	28.30	482.00	278.00	60.08
5/3/2010 1:09:00 AM	289.00	316.00	28.90	482.00	278.00	60.07
5/3/2010 1:10:00 AM	293.00	319.00	29.30	482.00	278.00	60.07
5/3/2010 1:11:00 AM	290.00	316.00	29.00	482.00	278.00	60.08

### Generator Engine Details

This section shows engine parameter details, such as battery voltage and oil pressure readings.

Generator Engine Details		
Generator: Gen 01		Nameplate: 1000 kW
Start Time: 5/3/2010 1:01:03 AM		Stop Time: 5/3/2010 2:06:21 AM
Measurement	Timestamp	Reading
<b>Battery Voltage (V)</b>		
	5/3/2010 1:02:00 AM	28.02
	5/3/2010 1:03:00 AM	28.02
	5/3/2010 1:04:00 AM	28.03
	5/3/2010 1:05:00 AM	28.00
	5/3/2010 1:06:00 AM	27.98
	5/3/2010 1:07:00 AM	27.98
<b>Oil Pressure (PSI)</b>		
	5/3/2010 1:02:00 AM	84.91
	5/3/2010 1:03:00 AM	66.36
	5/3/2010 1:04:00 AM	65.05
	5/3/2010 1:05:00 AM	65.05
	5/3/2010 1:06:00 AM	66.43
	5/3/2010 1:07:00 AM	72.86
	5/3/2010 1:08:00 AM	65.76
	5/3/2010 1:09:00 AM	65.03
	5/3/2010 1:10:00 AM	64.93

## Smart Device Data Collector

If the installation includes the EPSS, the Smart Device Data Collector is available. The Smart Device Data Collector is a web tool where you can manage your facility data, including:

- Record ATS load transfer data into Power Monitoring Expert for reporting and analysis. This web tool replaces the paper and spreadsheet method of recording ATS testing data.
- Log standard data for a generator, including battery voltage, coolant temperature, and oil pressure. This feature helps you enter more complete data so reports and analysis are more accurate.
- Log data for custom data values, such as for generator maintenance and cleaning tasks.

Power Monitoring Expert includes several reports that display transfer switch data and generator data submitted through the Smart Device Data Collector, including EPSS Test Report, Generator Test Report, Tabular Report, Trending Gadget, and Trending Report. The next section explains how to make sure submitted data appears in the reports and gadgets.

---

**NOTE:** The Smart Device Data Collector cannot be used to log data to Power Monitoring Expert until generators and ATS equipment have been set up in the Generator Performance Configuration Tool.

---

## Generator and ATS Data Workflow

---

**NOTE:** Data Collector can receive data from EPSS and generator systems. Depending on your system, you will need to configure your system using either the Generator Performance Configuration Tool or Generator Performance Configuration Tool with EPSS Test Module.

---

Data submitted through Smart Device Data Collector can be included in various reports and gadgets:

- EPSS or generator related data submitted through Data Collector can be included in the EPSS or Generator Test Report and show the Run record in the Run History.
- Non-EPSS or non-generator data can be included in other reports: Tabular Report and Trending Report.

Follow these steps to configure generators and ATS entities in the Generator Performance Configuration Tool to work with the Smart Device Data Collector tool.

1. Set up the generator meter in Management Console. See the *Power Monitoring Expert User Guide* for instructions to add and configure meters in Management Console.
2. Add the generator entity in the Generator Performance Configuration Tool or Generator Performance Configuration Tool with EPSS Test Module. Note the following:
  - The **Starting**, **Running**, and **Stopped** state values for the generator must be defined.
3. On the **Generators** tab, click **Edit Engine Data**. On the Engine Data Measurements screen, add the custom data values you want to log and report on.

4. Save the new data values and return to the **Generators** tab.
5. Click **Assign Engine Data**. On the Assign Engine Data screen, configure the measurement for each of the data values. Note the following:
  - **Source** - Select the generator source.
  - **Measurement** - Select a measurement with a name that begins with: WAGES External Input 1.
  - **Data Collector** - Check this option for the data value.
6. Save the data assignments and return to the **Generators** tab.
7. For the ATS data, make sure the **Data Collector** option is checked in the ATS properties. See "[Define Transfer Switches for EPSS](#)" on page 51 and note the following:
  - The **Normal**, **Test**, and **Emergency** state values for the ATS must be defined.
8. Verify the generator or ATS entities are included in a group on the **Groups** tab.
9. Login to the Smart Device Data Collector.
10. Enter and submit the generator or ATS data. See "[Log Generator Data](#)" on page 85.
11. Enter and submit the ATS test data. See "[Log Data for ATS Load Transfer Tests](#)" on page 81.
12. Login to Power Monitoring Expert and view the data in reports and gadgets:
  - EPSS or Generator Test Report - See "[EPSS Test Report](#)" on page 68. "[EPSS Test Report](#)" on page 68
  - Tabular Report - See the *Power Monitoring Expert Help* for instructions.
  - Trending Report - See the *Power Monitoring Expert Help* for instructions.
  - Trending Gadget - See the gadget online help for instructions.

## Start the Smart Device Data Collector

You can use any of these devices to open the Smart Device Data Collector.

- iOS(iPhone/iPad)
- Blackberry
- Android Phone/Tablet
- PC/laptop

The web tool can be accessed remotely at this URL:

```
http://<server_name>/DataCollector
```

A link to the web tool is also provided in the Power Monitoring Expert programs folder **Start > All Programs > Schneider Electric**:

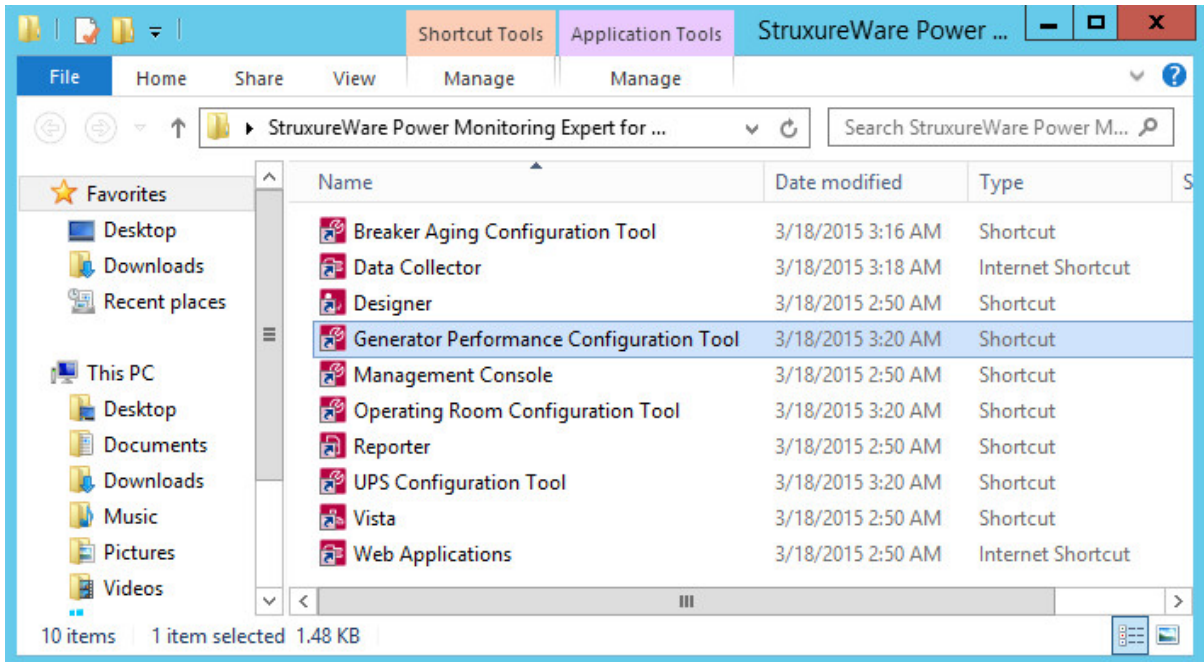

The Smart Device Data Collector uses the same login credentials as Power Monitoring Expert. It can only be accessed by users with the Controller, Operator, or Supervisor access level.

1. Go to the URL in a browser or use the shortcut in the programs folder. The sign in screen appears.

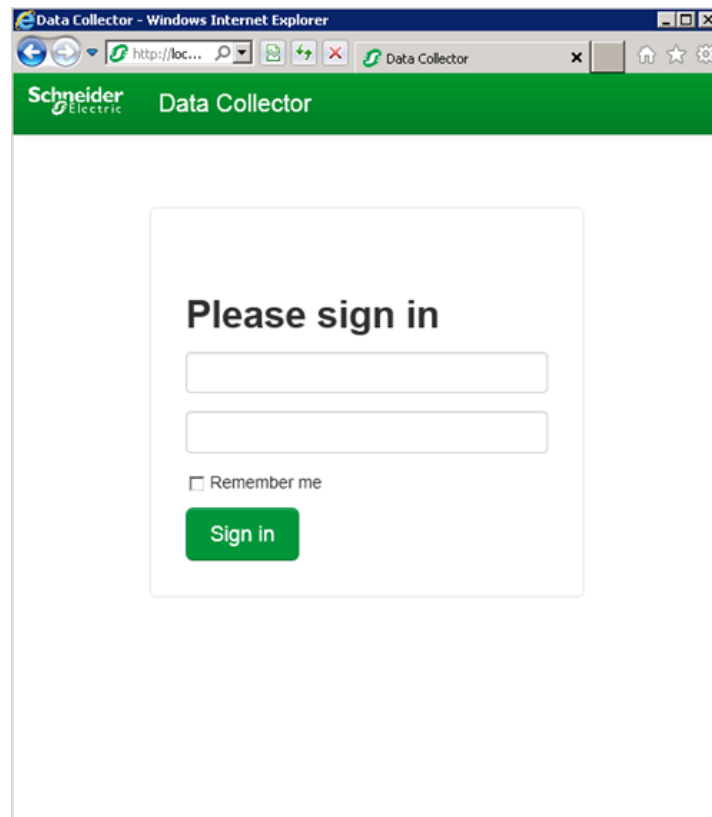

2. Enter your login credentials. The main screen appears.

The main screen contains the **Select Group** box (for generator groups, ATS groups, other equipment groups) and the **Select Equipment** box for a device in the selected group.

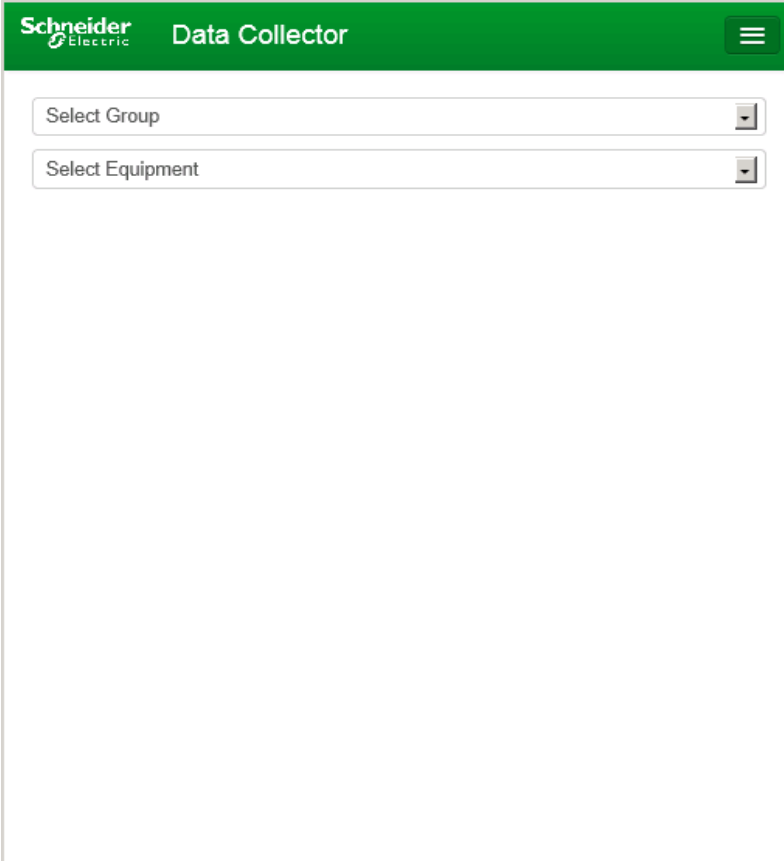

The screenshot shows the main interface of the Schneider Electric Data Collector. At the top, there is a green header bar containing the Schneider Electric logo and the text 'Data Collector'. Below the header, there are two dropdown menus: 'Select Group' and 'Select Equipment'. The rest of the page is white and currently empty.

An error message appears if you do not have the correct access level or you enter the wrong credentials.

The selection boxes are empty if the generators or ATS equipment have not enabled the Smart Device Data Collector option in the configuration tool.

To view the online help or sign out of the tool, click the menu button.

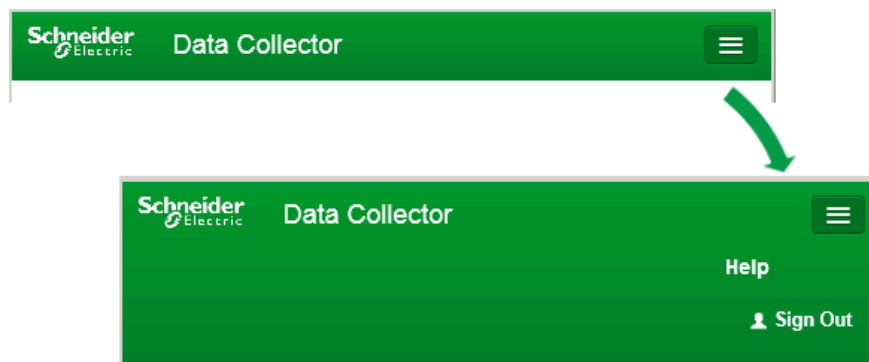

## Log Data for ATS Load Transfer Tests

When you test the ATS for generator load transfer, use the Smart Device Data Collector to mimic the ATS test sequence and store test data. This data can be compared to the ATS and generator settings configured in Generator Performance Configuration Tool with EPSS Test Module.

---

**NOTE:** This feature of the web tool is only available for installations that include the EPSS ordering option.

---

**NOTE:** In the configuration tool, verify the **Data Collector** option is enabled for the ATS you want to test. You can verify this in the Transfer Switches tab. See "[Edit Transfer Switch Properties](#)" on page 52 for instructions.

---

Follow these steps to perform the ATS test:

1. In the first two selection boxes, select the group and the ATS you want to evaluate.

The screenshot displays the Schneider Electric Data Collector web interface. At the top, there is a green header with the Schneider Electric logo and the text "Data Collector". Below the header, there are two dropdown menus: the first is set to "St Johns Main" and the second is set to "Main TS 1". Underneath, there is a "Test" section with three buttons: "Test Start" (highlighted in green), "Load Transfer", and "Test End". Each button has a corresponding empty input field to its right. Below the "Test" section is a "Result" section with a text area containing "(test not started)". At the bottom right of the result area are "Cancel" and "Submit" buttons.

- At the ATS control panel, start the test to power up the generator. Then, in the Smart Device Data Collector, click **Test Start**. This sets the start time of the ATS test.

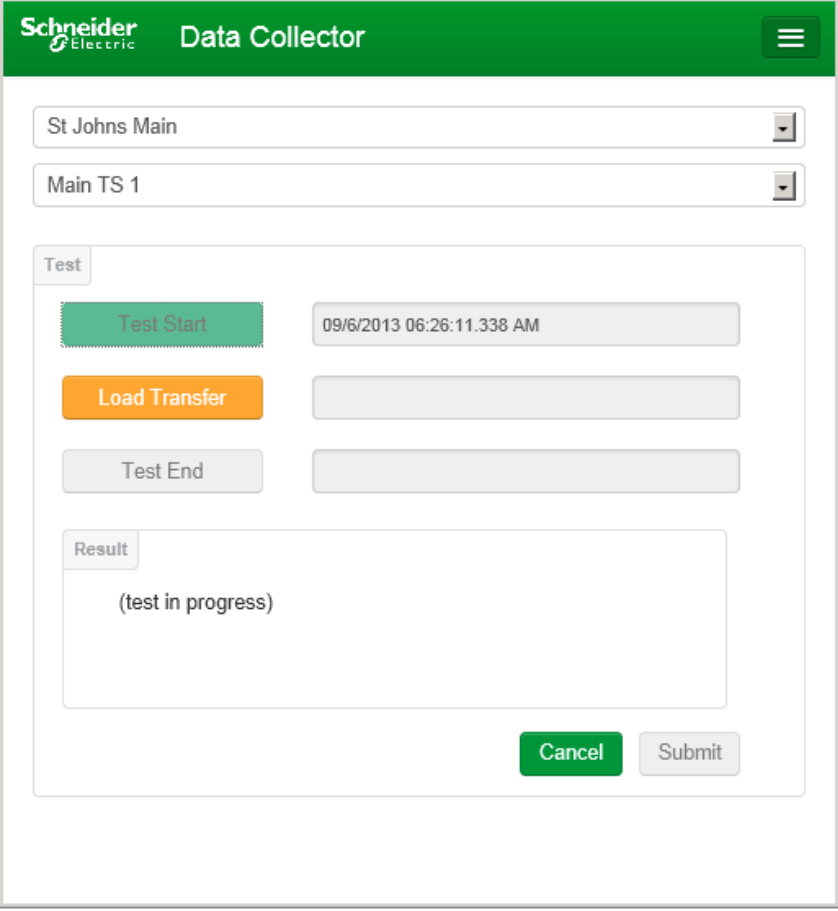

The screenshot displays the Schneider Electric Data Collector interface. At the top, there is a green header with the Schneider Electric logo and the text "Data Collector". Below the header, there are two dropdown menus: "St Johns Main" and "Main TS 1". The main content area is divided into two sections: "Test" and "Result".

In the "Test" section, there are three buttons: "Test Start" (green), "Load Transfer" (orange), and "Test End" (grey). The "Test Start" button is currently active, and a timestamp "09/6/2013 06:26:11.338 AM" is displayed next to it. The "Load Transfer" and "Test End" buttons are currently disabled.

In the "Result" section, there is a text box containing the text "(test in progress)". At the bottom right of the "Result" section, there are two buttons: "Cancel" (green) and "Submit" (grey).

3. Review the generator meter reading. When the load has transferred and the load threshold is reached, click **Load Transfer**. This sets the time the ATS transferred the load from utility to generator.

The screenshot displays the Schneider Electric Data Collector interface. At the top, there is a green header with the Schneider Electric logo and the text "Data Collector". Below the header, there are two dropdown menus: "St Johns Main" and "Main TS 1". The main content area is divided into two sections: "Test" and "Result".

The "Test" section contains three buttons and their corresponding timestamps:

Action	Timestamp
Test Start	09/6/2013 06:26:11.338 AM
Load Transfer	09/6/2013 06:26:31.656 AM
Test End	

The "Result" section displays the following information:

Transfer Time: 00:20:318  
(test in progress)

At the bottom right of the "Result" section, there are two buttons: "Cancel" and "Submit".

4. After the generator runs for the typical test duration, change the ATS back to normal operation.

5. Click **Test End**. This sets the stop time for the test.

The screenshot shows the Schneider Electric Data Collector interface. At the top, there is a green header with the Schneider Electric logo and the text "Data Collector". Below the header, there are two dropdown menus: "St Johns Main" and "Main TS 1". The main content area is divided into two sections: "Test" and "Result".

In the "Test" section, there are three buttons: "Test Start" (green), "Load Transfer" (orange), and "Test End" (red). To the right of each button is a timestamp in a grey box:

- Test Start: 09/6/2013 06:26:11.338 AM
- Load Transfer: 09/6/2013 06:26:31.656 AM
- Test End: 09/6/2013 06:27:12.060 AM

In the "Result" section, there are two lines of text:

- Transfer Time: 00:20:318
- Test Time: 01:00:722

At the bottom right of the "Result" section, there are two green buttons: "Reset" and "Submit".

6. Evaluate the test data in the **Result** box.
- **Transfer Time** – This is the difference between Load Transfer and Test Start.
  - **Test Time** – This is the duration the generator carried the load.
7. Reset the test or submit results.
- Click **Reset** if you want to discard the test data.
  - Click **Submit** when you are ready to submit data to the data server for logging. Green check marks appear in the **Result** box when data is sent successfully.

The screenshot shows the Schneider Electric Data Collector interface with the "Result" section highlighted. The "Result" box now contains two lines of text, each preceded by a green checkmark:

- ✓ Transfer Time: 00:20:318
- ✓ Test Time: 01:00:722

ATS timestamps are displayed in server time, submitted ATS states are entered in the database in UTC timestamp. The collected data will be logged to the database against configured group's sources and measurements. This data appears as a run in the run history.

## Log Generator Data

When you need to enter generator data into Power Monitoring Expert, you can use the Smart Device Data Collector to submit the data.

**NOTE:** In the Generator Performance Configuration Tool, verify the **Data Collector** option is enabled for the generator you want to log data for. See "[Assign Engine Data](#)" on page 49 for instructions. The custom data values you create in the configuration tool will appear in the web tool.

Follow these steps to log generator data:

1. In the first two boxes, select the group and specific generator you want to log data for. The custom data value fields, such as **Battery Volts**, for the generator appear.

The screenshot shows the Schneider Electric Data Collector web interface. At the top, there is a green header with the Schneider Electric logo and the text "Data Collector". Below the header, there are two dropdown menus. The first dropdown menu is set to "St Johns Main" and the second dropdown menu is set to "Main Gen 1". Below these dropdown menus, there are three data entry sections. Each section has a title, a "Set", "Edit", and "Clear" button, a text input field with "0" entered, a date input field, and a green "Submit" button. The sections are: "Battery Volts", "Coolant Temp", and "Engine Hours".

**NOTE:** The data value fields are the data values added in the configuration tool. For each data value, there is a value entry box and a date box.

2. For each data value, enter the new data in the box.

Battery Volts Set Edit Clear

24.12

Submit

- Click **Set** to set the timestamp for the new data.

Battery Volts Set Edit Clear

24.12

09/6/2013 07:01:10.567 AM

Submit

- If you want to edit the timestamp value, click **Edit** and enter the value. All date fields in use the MM/DD/YYYY format.

Battery Volts Set Edit Clear

24.12

09/6/2013 07:01:10.567 AM

Submit

3. Click **Submit** to log the new data.

When the data has been successfully logged, the field borders turn green and a green check mark appears. The submitted timestamp is in server time. In Power Monitoring Expert, the data is logged in UTC.

Battery Volts Set Edit Clear

✓ 24.12

✓ 09/6/2013 06:55:18.778 AM

Submit

An error message appears if a field is blank or has data with invalid format, as shown in these examples. Data with the incorrect format or blanks do not get stored in Power Monitoring Expert.

The screenshot shows a form titled "Battery Volts" with buttons for "Set", "Edit", and "Clear". It contains two input fields. The first field is empty and has a red "x" icon to its left. The second field is also empty and has a red "x" icon to its left. Below the fields, there are two red error messages: "The Value field is required." and "The TimestampUTC field is required." A "Submit" button is located at the bottom right of the form.

The screenshot shows a form titled "Battery Volts" with buttons for "Set", "Edit", and "Clear". It contains two input fields. The first field contains the text "abc" and has a red "x" icon to its left. The second field contains the timestamp "04/19/2013 03:10:46.955 PM" and has a green checkmark icon to its left. Below the fields, there is a red error message: "The value 'abc' is not valid for Value." A "Submit" button is located at the bottom right of the form.

4. To edit the data after you click **Submit**, click **Edit** and the fields become editable again.
5. Click **Clear** if you want to clear all the fields.

You can select other groups and devices to submit additional data.

# Generator Performance

To configure Generator Performance:

1. Obtain and install a license for the Generator Performance module.
2. Set up the installed ION meters, including ATS and generator frameworks. See ["ION Power Meter Configuration" on page 179](#) for details.

---

**NOTE:** Transfer Switches and Automatic Transfer Switches (ATS) does not apply to data centers. Even though ATS appears in the configuration tool and reports, you can ignore all references to ATS when configuring a data center facility.

---

3. Set up the installed non-ION meters, including digital and analog outputs. See ["Non-ION Power Meter Configuration" on page 201](#) for details.
4. Set up reporting entities in the configuration tool. See ["Generator Performance Configuration Tool" on page 89](#). If your system includes the ["Emergency Power Supply System \(EPSS\)" on page 34](#), see ["Generator Performance Configuration Tool with EPSS Test Module" on page 39](#).
5. Configure and run the Generator Performance reports.

# Generator Performance Configuration Tool

Use the Generator Performance Configuration Tool to configure the generators and other equipment for reporting the data and status of the power system.

If your installation includes the Emergency Power Supply System (EPSS), see ["Generator Performance Configuration Tool with EPSS Test Module" on page 39.](#)

## Prerequisites

- Before opening the configuration tool, make sure the sources - which represent metering devices - are added in Management Console and they are communicating.

## Start the Generator Performance Configuration Tool

To start the Generator Performance Configuration Tool, open the Power Monitoring Expert folder on the desktop and double-click the Generator Performance Configuration Tool shortcut.

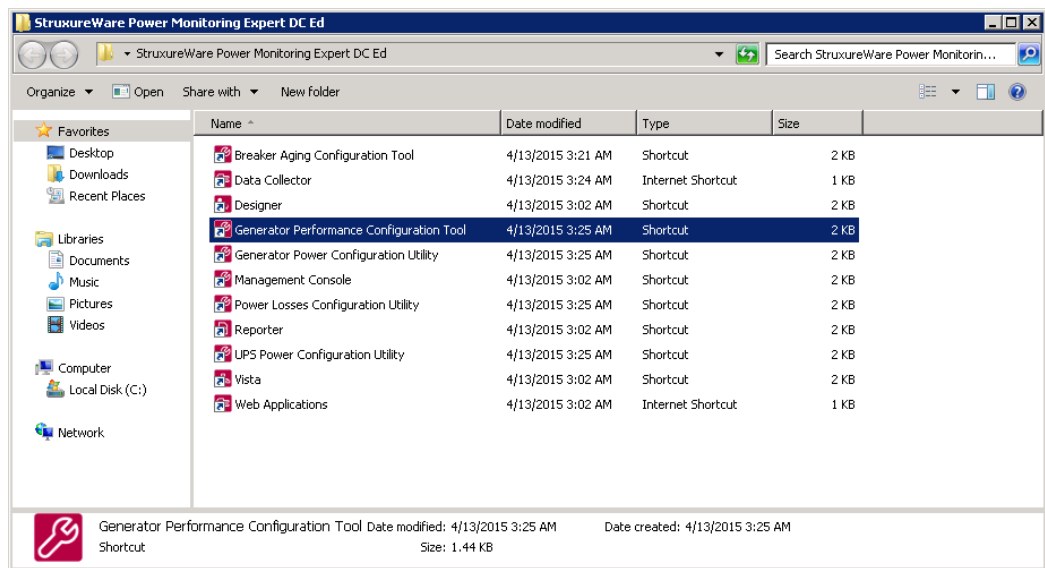

The Generator Performance Configuration Tool window contains these tabs: **Groups**, **Generators**, **Transfer Switches**, **Equipment**, and **Run History**. On these tabs, you create the entities and groups for equipment in the system. You also view data for prior test runs. The tabs contain a grid area and an editor area, as shown next. The grid area is initially empty but it will be populated with entries that you create through the editor area. Use the editor area to define the settings for new items, or to update the settings for an item that you select in the grid area.

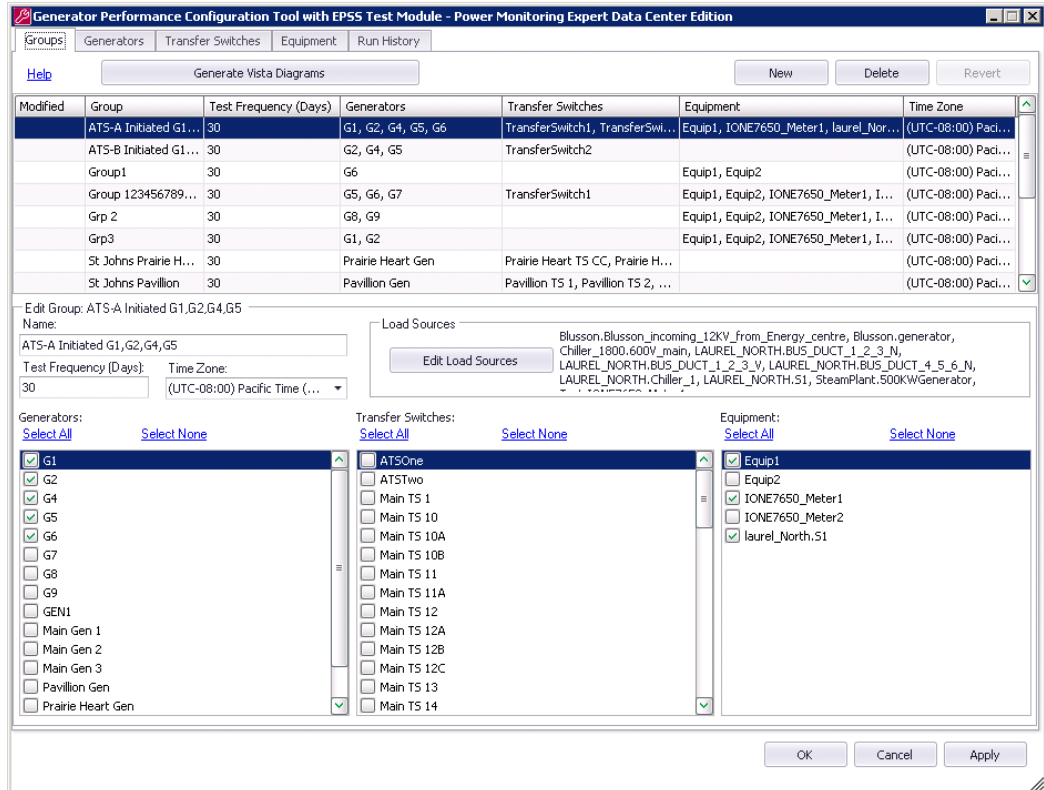

When you first use the configuration tool, you need to define generators and equipment on the applicable tabs. After you do this, define the device groups on the **Groups** tab.

**NOTE:** In order to use the reports, you must define the device groups on the **Groups** tab.

Use the following tabs to configure the tool:

- **Groups** tab - ["Define Groups" on page 95](#)
- **Generators** tab - ["Define Generators" on page 91](#)
- **Transfer Switches** tab - Define, describe and configure the transfer switches.
- **Equipment** tab - ["Define Equipment" on page 93](#)
- **Run History** tab - ["View Run History" on page 98](#)

Use the following common controls for the tabs:

- **Help** - Click this to view online help for the tab.
- **New** - Creates a new entry in the grid.
- **Delete** - Deletes the selected entry from the grid.
- **Revert** - Returns a modified record to its original values, if **OK** or **Apply** have not been clicked.
- **OK** - Saves all changes and exits the configuration tool.
- **Cancel** - Exits the tool without saving changes.
- **Apply** - Saves all changes and leaves the tool open.

The **Modified** column in the grid area shows the status of the row data:

+ (plus) - a new entry.

\* (asterisk) - a modified entry.

! (exclamation mark) - entry needs more information before it can be saved.

## Define Generators

Use the **Generators** tab to create or update entities representing the generators in the power supply system. Complete this tab if you need to produce reports for generators.

The screenshot shows the 'Generator Performance Configuration Tool with EPSS Test Module - Power Monitoring Expert Data Center Edition' window. The 'Generators' tab is active, displaying a table with the following data:

Modified	Name	Description	Source	Nameplate Rating	Nameplate Unit	Evaluation Method
	G1	Test Auto	EPSS.G1	100	kW	Load
	G2	Test Auto	EPSS.G2_ATSA	1600	kW	Load
	G4	Test Auto	EPSS.G4	100	kW	Load
	G5	Test Auto	EPSS.G5_ATSB	1600	kW	Load

The 'Edit Generator: G1' dialog box is open, showing the following configuration options:

- Name:** G1
- Description:** Test Auto
- Electrical Data:**
  - Source: EPSS.G1
  - Prime Nameplate Rating: 100
  - Unit: kW
- Engine Temperature Data:**
  - Source: Unassigned
  - Unit: C
  - Measurement: Unassigned
- Exhaust Gas Temperature Data:**
  - Source: Unassigned
  - Unit: C
  - Measurement: Unassigned
  - Radio buttons: Single Exhaust (selected), Dual Exhaust
- Evaluation Method:** Load
- Engine Data Measurements:** Assign Engine Data
- Status Measurements:**
  - Source: EPSS.G1
  - Starting: No Measurement selected, Active Value 1
  - Running: EPSS\_Run, Active Value 1
  - Stopped: EPSS\_Run, Active Value 0
  - Monitor for EPS Available? No Measurement selected, Active Value 1, Req. Time (Seconds)
  - Battery Waveforms: EPSS.G1, Measurement: V2 Waveform

You can perform the following actions on this tab:

- Click **New** to define the properties of the generators in the system. See ["Edit Generator Properties" on page 92](#).
- Click **Clone** to define a new generator that is similar to an existing generator. The system copies many details of the existing device into the new entry. You can then enter the unique details of the new device. If you need to define several devices that are similar, this feature can help you define them quickly. See ["Clone Generator Properties" on page 92](#).
- Click **Delete** to remove records from the system.
- Click **Revert** (before you click **Apply** or **OK**) if you make changes to a record and want to revert to your initial settings.

## Edit Generator Properties

The **Edit Generator** area on the tab is used to create a generator entry and to define specific values for it.

1. On the **Generator** tab, click **New**.
2. Complete the following fields to define a generator.
  - **Name** - Enter a unique name to identify the generator.
  - **Description** (Optional) - You can add specific information about the generator, such as make and model.
  - **Electrical Data**
    - **Source** - Select a source name. The source represents the device that records the electrical data from the generator.
    - **Prime Nameplate Rating** - Enter the maximum power load for the generator. Refer to the generator's nameplate for this value.
    - **Unit** - Select the unit of measurement for the power load.
  - **Battery Waveform** (Optional) - Use this area to if you want to configure and generate the Battery Health Report. To enable the report, check the box and complete these fields:
    - **Source** - Select a source name that is performing the waveform capture. This option is available for ION 7550 and ION 7650 meters.
    - **Measurement** - Select the measurement recording the battery waveform. For a typical configuration, this is the V4 waveform.
 

Specific frameworks for the battery voltage waveform must also be configured. See ["Generator Battery Health" on page 106](#) for additional instructions.
  - **Status Measurements** - These fields are not required.
3. Click **Apply** to save the changes and remain on the tab.
4. Repeat these steps to define other generators.
5. If you are defining several similar generators, use the **Clone** button. See ["Clone Generator Properties" on page 92](#).

## Clone Generator Properties

You can use the clone feature to copy the properties of an existing generator entity and use those properties as the baseline for multiple generators. The clone feature can help you define several similar generators quickly.

1. On the **Generators** tab, select the generator you want to use as the baseline for another generator.
2. Click **Clone** to create a new generator based on a selected entity. Many fields are copied from the selected generator. The fields which are not copied have an information icon to indicate where you need to enter data, as follows:
  - **Name** - Enter a unique name to identify the generator.

- **Electrical Data - Source** - Select a source name from the dropdown list. The source represents the device that records the electrical data from the generator.
- **Status Measurements - Source** - Select a source name. The source represents the metering device that records the status of a generator.

For information about other generator properties, see the previous section "[Edit Generator Properties](#)" on page 92.

3. Click **Apply** to save the new generator entity.

## Define Equipment

Use the **Equipment** tab to create a logical device with a source measurement and rating. You can add these logical devices to device groups for reporting. Complete this tab if you need to produce reports for equipment capacity.

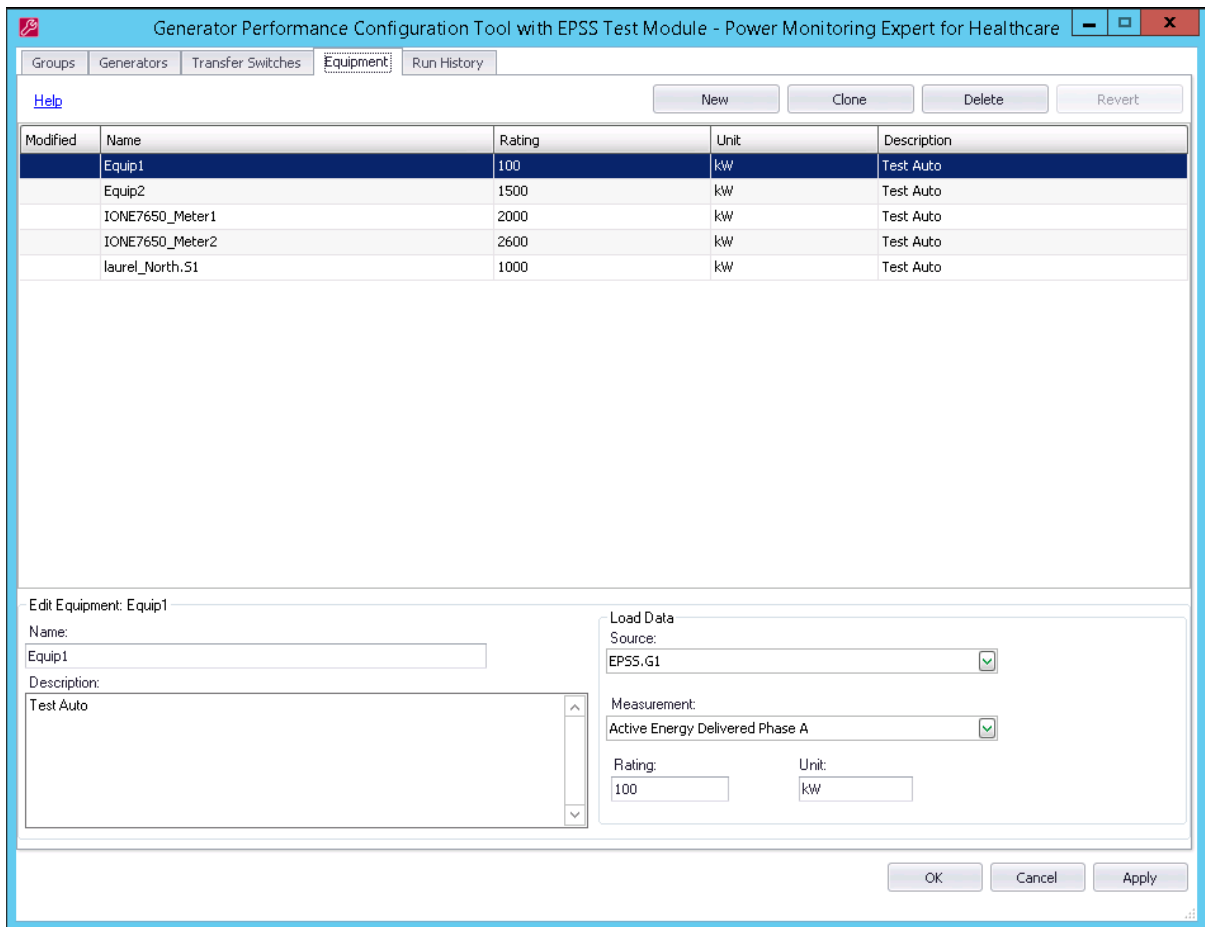

You can perform the following actions on this tab:

- Click **New** to enter new record for a device. See "[Edit Equipment Sources](#)" on page 94 for instructions to define the devices.

- Click **Clone** to copy an existing record and make minor changes. The system copies many details of the existing device into the new entry. You can then enter the unique details of the new device. If you need to define several devices that are similar, this feature can help you define them quickly.
- Click **Delete** to remove records from the system.
- Click **Revert** (before you click **Apply** or **OK**) if you make changes to a record and want to revert to your initial settings.

## Edit Equipment Sources

The **Equipment** tab displays the equipment load sources and measurements defined in the system.

1. Click **New** to create a record.
2. Complete these fields:
  - **Name** - Enter a unique name to identify the record.
  - **Description** - Enter additional information about the device. Optional.
  - **Source** - Select the load source for the device.
  - **Measurement** - Select the measurement for the device.
  - **Rating** - Enter the maximum rated load for the device.
  - **Unit** - Enter the unit of the measurement.
3. Click **Apply** to save the record and remain on the tab.
4. Repeat these steps to enter additional devices.

# Define Groups

A performance group is a combination of generators and other equipment for reporting. The **Groups** tab must be completed before you can configure and produce any reports.

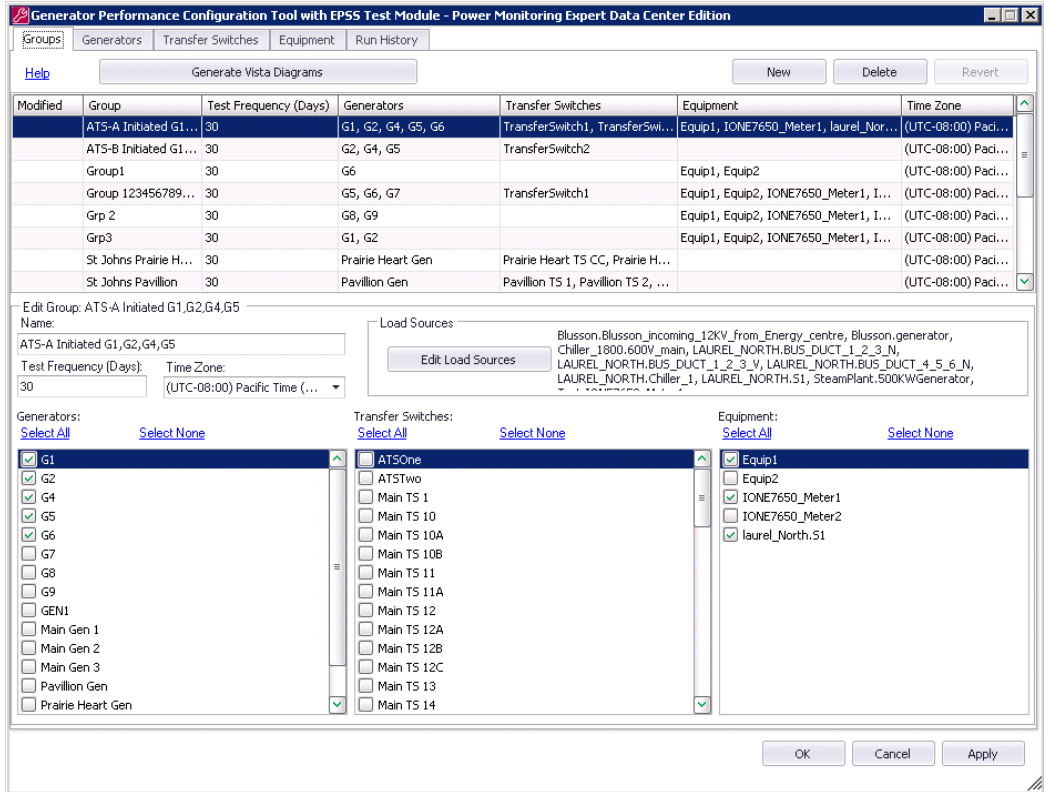

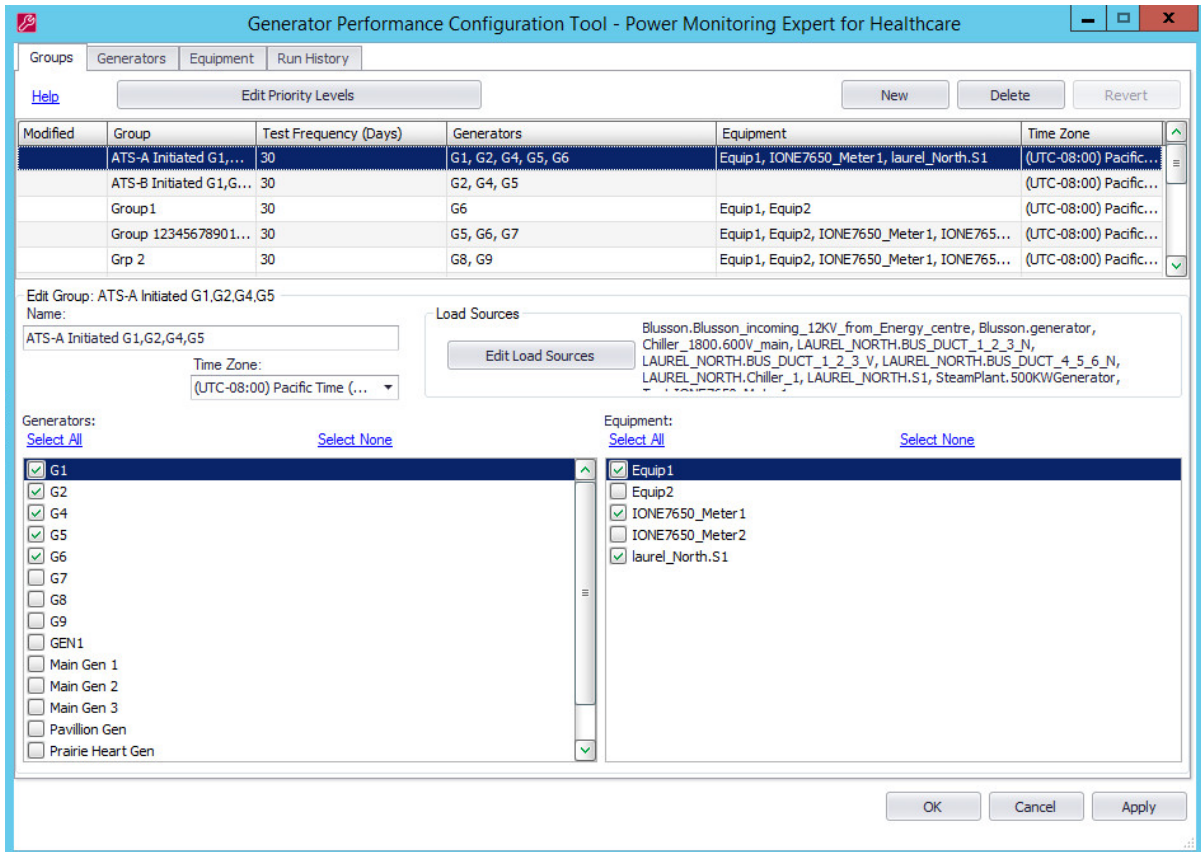

You can perform the following actions on this tab:

- Click **New** to create a new group for generating reports. A group can contain any device that has been configured on the other tabs. See ["Edit Groups" on page 96](#) for instructions to define the groups.
- Click **Delete** to remove records from the system.
- Click **Revert** (before you click **Apply** or **OK**) if you make changes to a record and want to revert to your initial settings.
- Click **Edit Priority Levels** to create or modify response times for devices and equipment. See ["Edit Group Priority Levels" on page 97](#) for instructions.
- Click the **Edit Load Sources** to associate a group with the electrical loads that the group of generators must carry in a power outage. See ["Edit Group Load Sources" on page 98](#) for instructions.

## Edit Groups

The **Groups** tab displays the device groups defined in the system. The generators and other equipment must be defined on their respective tabs before you can add them to a group.

1. Click **New** to create a group.
2. Complete the following to define the values for a group:
  - **Name** - Enter a unique name to identify the group.
  - **Generators** - Select the generators to include in the group.

- **Equipment** - Select the equipment to include in the group.

The **Select All** and **Select None** options let you work easily with large numbers of sources by selecting all check boxes or clearing all check boxes at the same time.

3. Click **Apply** to save the group and remain on the tab.
4. Repeat these steps to create other groups.

## Edit Group Priority Levels

The following reports use priority levels:

- Generator Capacity Report – Priority level values are required to accurately display the colors indicated in the priority levels.
- EPSS Test Report – Priority level values are required for the ATSS in the system to PASS or FAIL an ATS based on the required transfer time of the priority level.

Default priority levels are setup as default.

The **Edit Priority Levels** editor is used to select at least one priority level that you want to apply to the equipment groups. The default priority level names and transfer times are:

- Critical - 10 sec
- Equipment - 30 sec
- Life Safety - 10 sec

You can change any of these names and transfer times and add new priority levels as necessary.

1. Click **Edit Priority Levels**. The **Priority Levels** screen appears.

Modified	Name	Required Transfer Time	Color
	Critical	10	Red
	Equipment	30	Blue
	Life Safety	10	Yellow

Name:

Required Transfer Time (Seconds):

255, 0, 0

2. Click **New** to add a priority level.
3. Complete the following to define priority levels:
  - **Name** - Enter a unique name to identify the priority level.

- **Required Transfer Time (Seconds)** - Enter the transfer time in seconds. This time indicates the maximum acceptable time it takes the equipment to move from the **Test** state to the **Emergency** state.
  - **Color** - Click the color box to select a color for the priority level. This color appears on the Generator Capacity Report summary page, where the generator loads are compared.
4. Click **OK** to save the priority level and return to the **Groups** tab.

## Edit Group Load Sources

On the **Edit Load Sources** screen, you can associate an equipment group with the various electrical loads that the equipment must carry during a power outage.

Define the priority levels for the system before you configure load sources. See "[Edit Group Priority Levels](#)" on page 97 for instructions.

1. Click **Edit Load Sources**. The **Select Load Sources** screen appears.

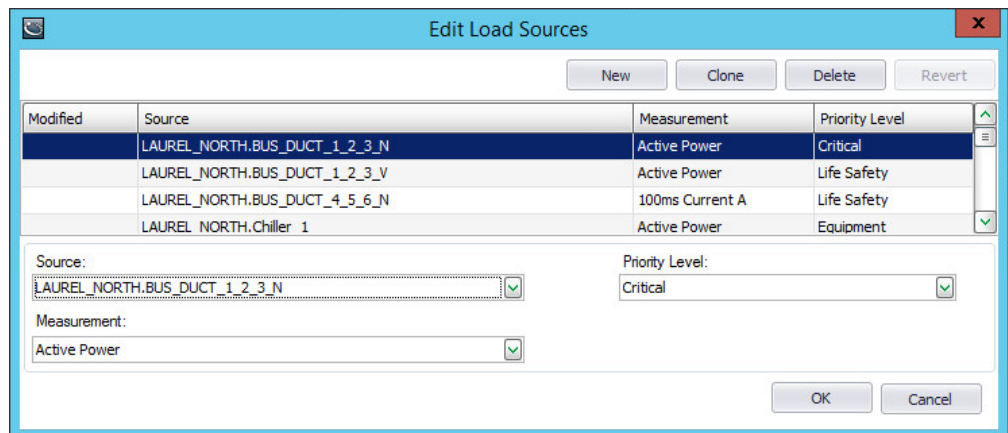

2. Click **New** to add a load source.
3. Complete these fields:
  - **Source** - Select the measurement source.
  - **Measurement** - Select the measurement to monitor.
  - **Priority Level** - Select the priority level to assign to the load source.
4. Click **OK** to save the new load source and return to the **Groups** tab.

You can use the **Clone** button to associate an equipment group with several sources where the load is logged against the same measurement. The cloned group contains the same measurement and priority level as the original.

## View Run History

Use the **Run History** tab to view or modify run activities that represent the Test, Load Shedding, and Power Outage activities that have occurred in the system. The history

indicates when components of the power system have become active, such as when a generator was running. The runs stored in history can be used as input for reports and dashboards.

Because the system stores the history of these activities, you can generate useful reports about the equipment operation. The reports can identify when the system was active, why the system was active, and what devices were active.

The screenshot displays the 'Generator Performance Configuration Tool - Power Monitoring Expert for Healthcare' interface. The 'Run History' tab is active, showing a table of power system runs. Below the table, an 'Edit Run History' dialog box is open for a specific run.

Modified	Group	Run Name	Start	End	Reason	Active Sources
	Group 1234567890123...	Saturday, March 28, 20...	3/28/2015 7:00:51 AM	3/28/2015 8:10:46 AM	Test	G5
	ATS-B Initiated G1,G2,...	Saturday, March 28, 20...	3/28/2015 7:00:50 AM	3/28/2015 8:10:46 AM	Test	G2, G4, G5
	Grp3	Saturday, March 28, 20...	3/28/2015 7:00:50 AM	3/28/2015 8:10:46 AM	Test	G1, G2
	ATS-A Initiated G1,G2,...	Saturday, March 28, 20...	3/28/2015 7:00:50 AM	3/28/2015 8:10:46 AM	Test	G1, G2, G4, G5
	Group 1234567890123...	Saturday, March 21, 20...	3/21/2015 6:49:40 AM	3/21/2015 8:06:15 AM	Test	G5
	Grp3	Saturday, March 21, 20...	3/21/2015 6:48:52 AM	3/21/2015 8:06:40 AM	Test	G1, G2
	ATS-B Initiated G1,G2,...	Saturday, March 21, 20...	3/21/2015 6:48:52 AM	3/21/2015 8:06:24 AM	Test	G2, G4, G5
	ATS-A Initiated G1,G2,...	Saturday, March 21, 20...	3/21/2015 6:48:52 AM	3/21/2015 8:06:40 AM	Test	G1, G2, G4, G5
	Group 1234567890123...	Saturday, March 14, 20...	3/14/2015 6:57:42 AM	3/14/2015 8:06:13 AM	Test	G5
	ATS-B Initiated G1,G2,...	Saturday, March 14, 20...	3/14/2015 6:57:41 AM	3/14/2015 8:06:13 AM	Test	G2, G4, G5
	Grp3	Saturday, March 14, 20...	3/14/2015 6:57:41 AM	3/14/2015 8:06:13 AM	Test	G1, G2
	ATS-A Initiated G1,G2,...	Saturday, March 14, 20...	3/14/2015 6:57:41 AM	3/14/2015 8:06:13 AM	Test	G1, G2, G4, G5
	Grp3	Saturday, March 7, 201...	3/7/2015 5:57:47 AM	3/7/2015 7:09:03 AM	Test	G1, G2
	Group 1234567890123...	Saturday, March 7, 201...	3/7/2015 5:57:47 AM	3/7/2015 7:09:03 AM	Test	G5
	ATS-B Initiated G1,G2,...	Saturday, March 7, 201...	3/7/2015 5:57:47 AM	3/7/2015 7:09:04 AM	Test	G2, G4, G5
	ATS-A Initiated G1,G2,...	Saturday, March 7, 201...	3/7/2015 5:57:47 AM	3/7/2015 7:09:04 AM	Test	G1, G2, G4, G5

**Edit Run History: Group 123456789012345678901234567890**

Name: Saturday, March 28, 2015 (UTC -07)

Start - End: 3/28/2015 7:00:51 AM - 3/28/2015 8:10:46 AM

Reason: Test

Active Generators: G5

Buttons: OK, Cancel, Apply

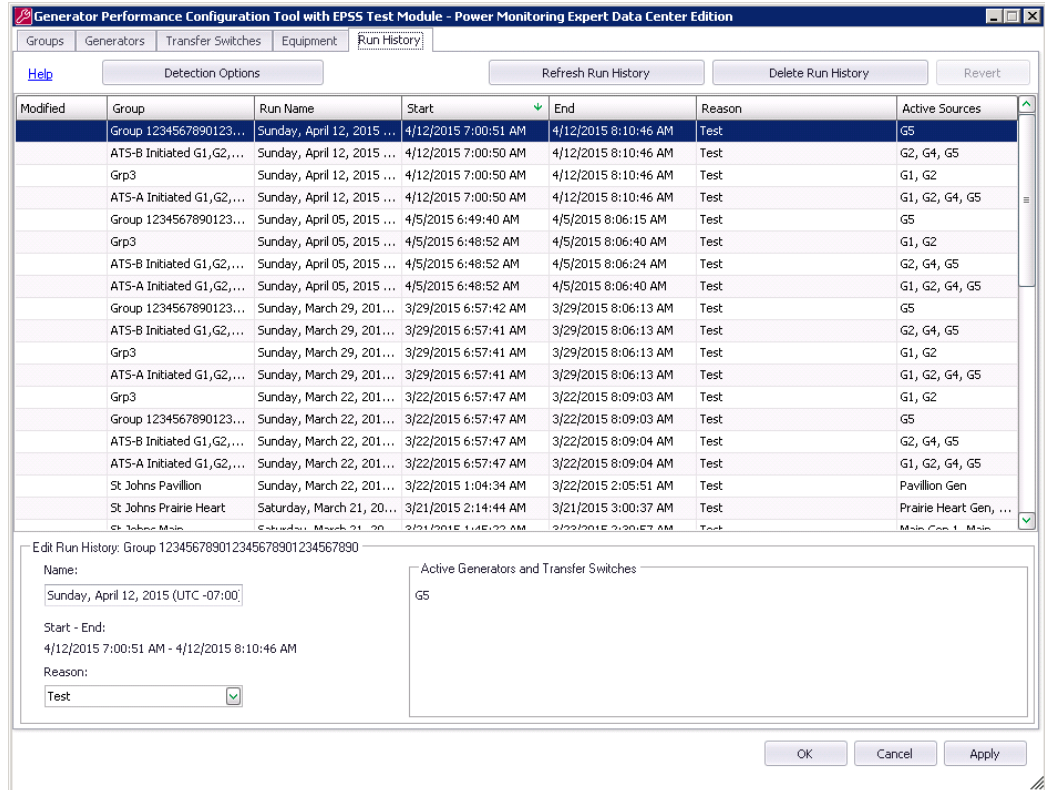

The first time the history records are generated on the **Run History** tab, the system may take a long time depending on the amount of history present in the system. When changes occur in the equipment configuration, the run history must be generated again.

For example if you remove a generator from a group, the run history for that group needs to be rebuilt because that generator may have been the reason for the detection of a run. Now that the generator is not part of the group, the system needs to build the run history again to have accurate data.

You can perform the following actions on this tab:

- Click **Detection Options** to modify the criteria of a run event that will cause it to appear on this tab. See "[Modify Run Detection Options](#)" on page 100.
- Click **Refresh Run History** to update the tab with the latest run events that have occurred in the system.
- Click **Delete Run History** to remove all run event records from the tab.
- Modify the name and run reason for a run event. See "[Modify Run Details](#)" on page 101.

## Modify Run Detection Options

The run detection options can be defined to help guard against bad data in the system. To record actual run activities, you can set the parameters so the system only records runs that fall within the criteria.

The minimum run length value is present to prevent false positives, which may occur during commissioning when the states of the generators are changing quickly and seemingly at random. This may be due to signals being recorded that really do not reflect actual generator activity.

You can set the maximum run length to eliminate "hanging" runs. A hanging run occurs when the stop signal for a generator is not recorded properly. As a result, every week during the test it records a running signal but there is no way for the system to know when it stops. If the system does not see a stop signal, it sets the end of the run to be the start of the run plus the maximum run duration. Therefore you cannot determine how long the generator was actually running.

Complete the following steps to define the run criteria for the system to store runs in history.

1. Click **Detection Options**. The **Run Detection Options** screen appears.

2. Change the values in the minimum and maximum fields.
3. Click **OK** to save the changes and return to the **Run History** tab.
4. Click **Refresh** to update the tab with the run events that match the new detection criteria.

## Modify Run Details

The system defines run data, such as name, start time, end time, reason, and active sources automatically. You can change the name of the run event and the reason for the run.

- The default run name is the start date of the run, such as `June 12 2015`. If a group has multiple runs on the same date, the subsequent runs have the same date with the run number appended, such as `June 12 2015 Run 2` and `June 12 2015 Run 3`.
- The system automatically detects the reason for the run. If the detected reason is incorrect, you can change the reason. For example, the reason appears as `Test`, but the run is actually `Load Shedding`.

Other details about the run event cannot be modified directly. If the sources for a run are not correct, you can exclude or include specific sources when generating a report based on this run.

1. Click the run record you want to modify. The run details appear below the grid.
2. In the **Name** field, change the suggested run name as necessary.
3. In the **Reason** list, select the correct reason for the run.
4. Click **OK** to save the changes for the run.

# Generator Activity Report

The **Generator Activity Report** shows the test run hours and other test run data for each generator in the selected group.

## WARNING

### INACCURATE REPORT RESULTS

- Do not incorrectly configure the devices and software. This can lead to inaccurate reports and/or data results.
- Do not rely solely on system reports to determine if the system is functioning correctly or meeting all applicable standards and requirements.
- Use system reports as a supplement to proper workplace practices or equipment maintenance, not as a substitute.

**Failure to follow these instructions can result in death, serious injury, or equipment damage.**

## Report Prerequisites

In the Generator Performance Configuration Tool, define the following tabs and fields in order to generate the report:

### Generators Tab

- **Name** - The generator entity needs a name.
- **Electrical Data** - Specify the required measurement source, nameplate rating, and unit of measurement.
- **Status Measurements** - The source of the status measurement and the start, run, and stop values must be selected. Configure the meters that provide these measurements.
- **Evaluation Method** - "Load" is default, but this may be changed to accommodate customer requirements.

For instructions on the above settings see either of these sections:

- For Generator Performance Configuration Tool, see ["Define Generators" on page 91](#).
- For Generator Performance Configuration Tool with EPSS Test Module, see ["Define Generators for EPSS" on page 42](#).

## Configure and Generate the Generator Activity Report

Use the Reports module in Web Applications to configure and generate the Generator Activity Report.

---

**NOTE:** Emergency Power Supply System (EPSS) is a North American term used in the healthcare segment. "EPSS Group" refers to the "Groups" defined in the Generator Performance Configuration Utility.

---

1. Complete the fields to define the report:
  - **Title** - Enter a name for the report.
  - **EPSS Group** - Select the group for which the report is intended. When you select a group in the list, the field to the right shows the devices included in the group.
  - **Exclude Sources** - Click this to define the sources to exclude from the report.
    - a. In the **Sources Included** area, select sources to exclude and then click **>** to move those sources to the **Sources Excluded** area.
    - b. To move all of the sources into the **Sources Excluded** area, click **>>**.
    - c. Click **OK** to save the sources and return to the report template. The devices in the group will appear in the **Sources** section of the generated report. Excluded devices will appear as grayed-out entries.
  - **Reporting Period** - Select the date range for the data you want to include. This can be a fixed number of prior days, such as Last 7 Days, or a fixed date range. The initial setting is `Last 7 Days`. In the US, select at least 30 days of load data recorded at 15 minute intervals to satisfy regulations. Also select the type of timestamp to use in the report, either `Server Local Time` or `UTC (Universal Time)`.
  - **Threshold (Hours)** - Enter the maximum number of hours the generators should run in non-emergency use. Enter a value that is in compliance with local authority requirements. For example, in the US, the EPA requires that generators can run no more than 100 hours in non-emergency use.
  - **Include Activity Details** - Click **Yes** to include the generator details in the report. Click **No** to exclude this section.
  - **Include Data Warnings** - Click **Yes** to include data warnings in the report. If there are none, the section is not included. Click **No** to exclude this section.
2. Click **Generate Report** to produce the report.

## Generator Activity Report Example

### Summary Page

The first page of the report shows the title, company name, group, a bar graph representing the test run hours on each generator, and a table of test run data for each generator.

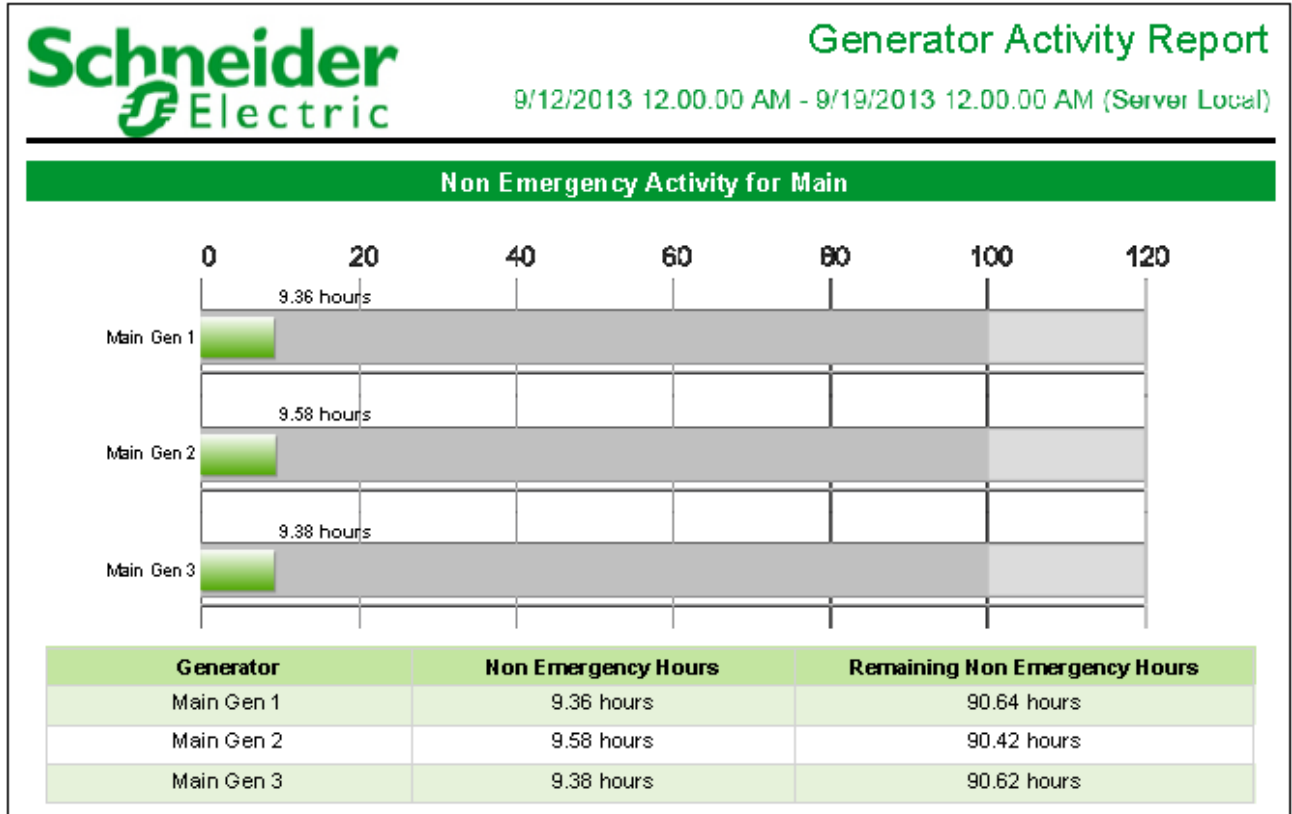

### Details Page

The details page shows a pie chart of the type of hours for each generator and the total run time table.

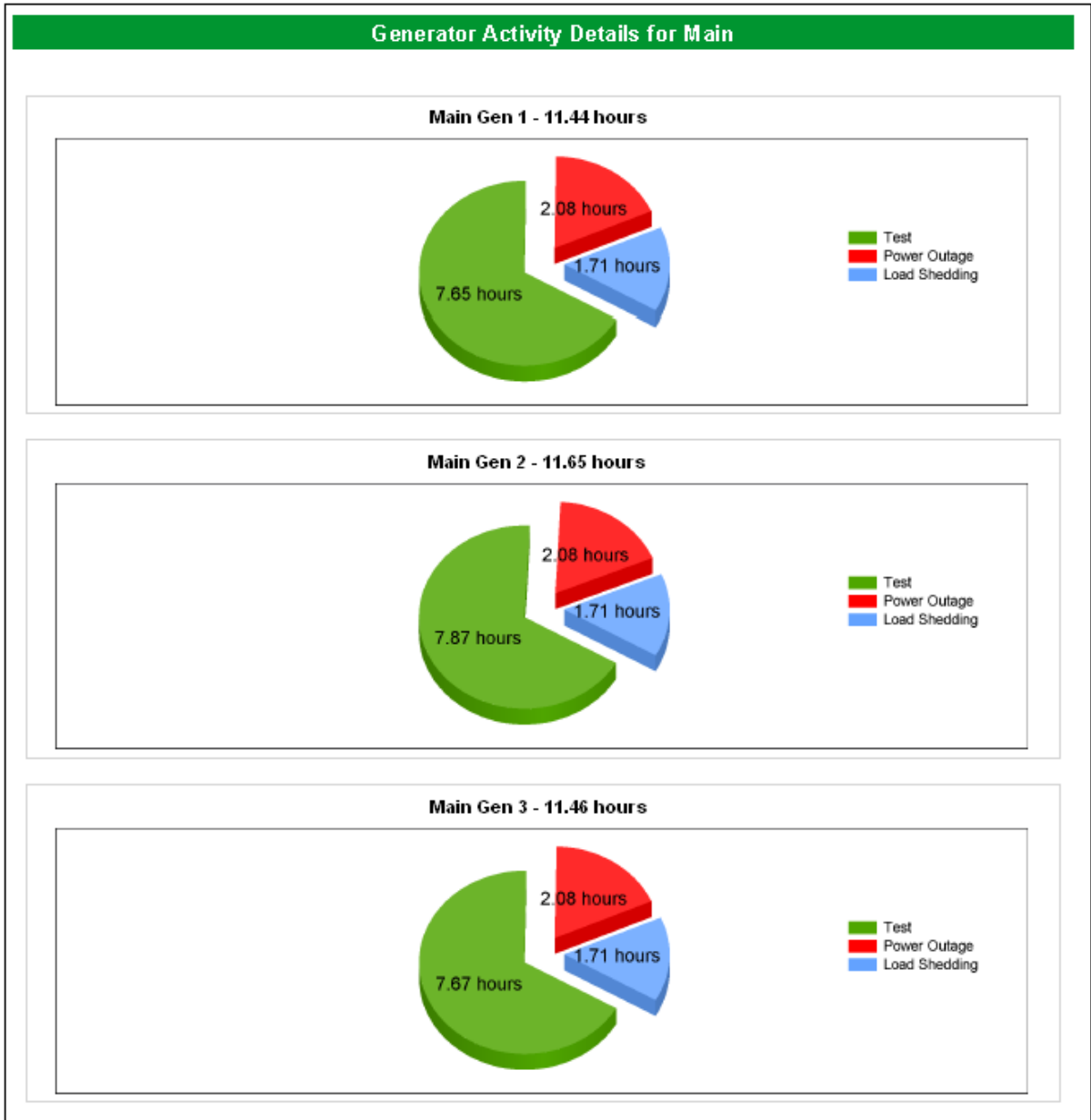

## Generator Activity Report

9/12/2013 12:00:00 AM - 9/19/2013 12:00:00 AM (Server Local)

Main				
Generator	Start Time	Stop Time	Duration (hours)	Run Reason
Main Gen 1	9/12/2013 7:00:50 AM	9/12/2013 8:10:45 AM	7.65	Test
Main Gen 2	9/12/2013 7:00:50 AM	9/12/2013 8:10:46 AM	7.87	Test
Main Gen 3	9/12/2013 7:00:51 AM	9/12/2013 8:10:45 AM	7.67	Test

# Generator Battery Health

The Generator Battery Health system contains several components that provide the customer with information about the generator battery bank. Specifically, the monitor shows the customer the starting voltage signature, which indicates the battery bank's voltage drop and recovery during and after starting the generator.

The following tasks must be completed to set up the Generator Battery Health system:

- Install and configure the ION7550 / ION7650 meter to the battery bank to be monitored. Refer to the *PowerLogic ION7550 / ION7650 Installation Guide* and *PowerLogic ION7550 / ION7650 User Guide* for more information. Obtain the latest version of these documents from [www.schneider-electric.com](http://www.schneider-electric.com).

Note the following:

- Digital signal from the Crank relay connected to the digital input of the ION7550/ ION7650 meter. This is the signal that triggers that triggers the oneshot timer to start recording waveform
- V1 - V3 voltage inputs must have PTs in order to isolate the ground from the system being monitored and the battery.
- Connect V4 to the positive side of the battery. Input impedance of V4 terminal is 5 Mohm (phase - Vref). For the most up to date specification, contact the local representative.
- Connect Vref to battery ground.
- Fusing must be installed according to the meter installation instructions.
- Perform visual inspection of connections to help ensure there is physical separation between the system connected to V1, V2 and V3, and the battery connected to V4.
- For other wiring options with PTs, see the *PowerLogic ION7550 / ION7650 Installation Guide*.

## DANGER

### EQUIPMENT ELECTRIC SHOCK, EXPLOSION, OR ARC FLASH

Treat the battery circuit as energized to the category of the installation.

**Failure to follow these instructions will result in death or serious injury.**

Refer to the following diagram as an example for connections to the meter.

#### 4-Wire Wye, 3-Element, 3 PTs Connection Diagram

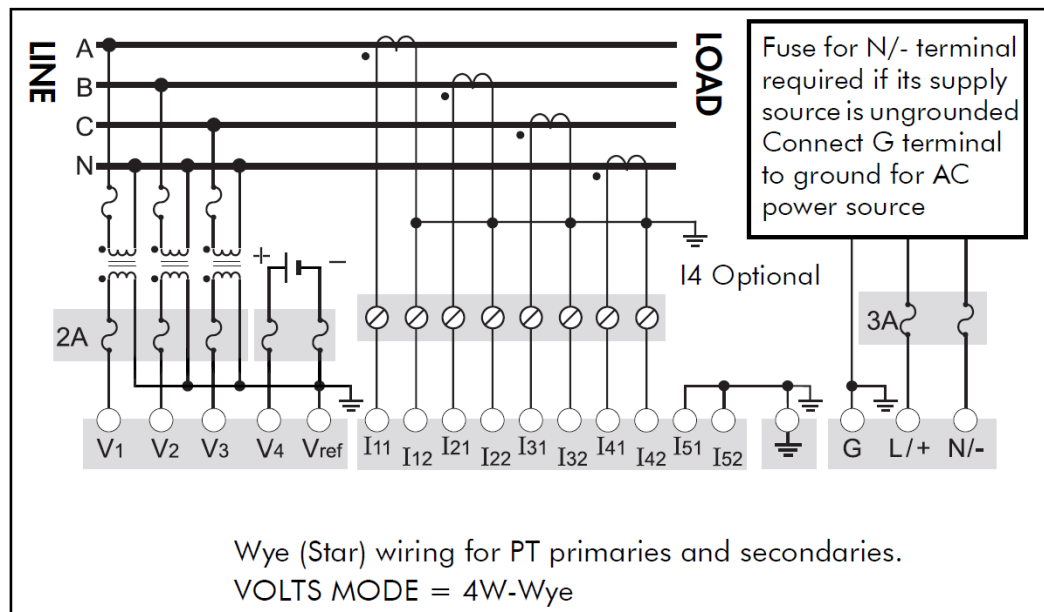

- Configure the Battery Health Framework to capture the battery voltage signature or waveform and deploy the framework to the meter. See the next section for instructions.
- In the Generator Performance Configuration Tool, check the Battery Waveforms option for the generator to be included in the customer's Battery Health report. See ["Edit Generator Properties" on page 92](#) or ["Edit Generator Properties" on page 92](#) or ["Edit Generator Properties" on page 43](#) for instructions.
- Configure the Generator Battery Health Report to display the graph of the voltage signature. The customer can use the report to help understand the battery bank condition. The report can display multiple generators for the same starting date or a single generator on multiple starting dates. See ["Configuring and Running the Battery Health Report" on page 115](#).

This chapter provides instructions for configuring the framework to capture the voltage signature.

## Configure the Battery Health Framework

The Battery Health Framework is designed to capture and record a generator's battery voltage signature at start up. This voltage signature provides some indication of the health of the generator's battery bank. A typical waveform capture of the voltage drop when starting is shown next:

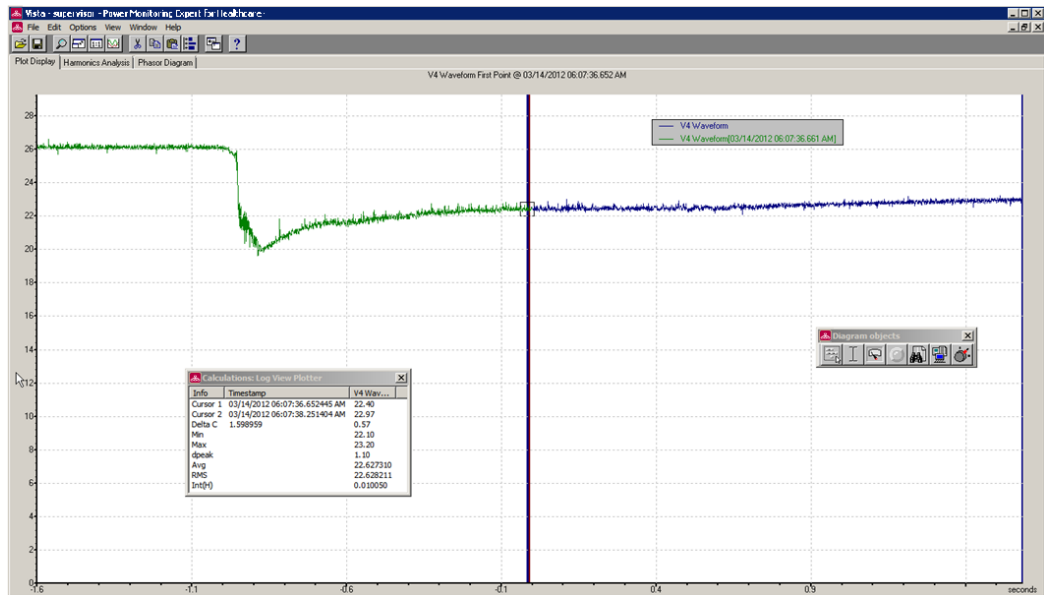

Note the following items about this example:

- This capture shows about 4 - 5 seconds worth of data, accomplished via 3 waveform recorders in series configured at a resolution of 16x96.
- The voltage does not immediately recover to its original value (~26 v) but it begins to ramp up.
- There is about 0.5 seconds of data before the voltage drop to approximately 20 v.

Two options in the framework are possible to capture the waveform, based on how the crank relay signal is triggered - pulse or KYZ.

### Example Framework

The following figure shows the typical modules for the framework.

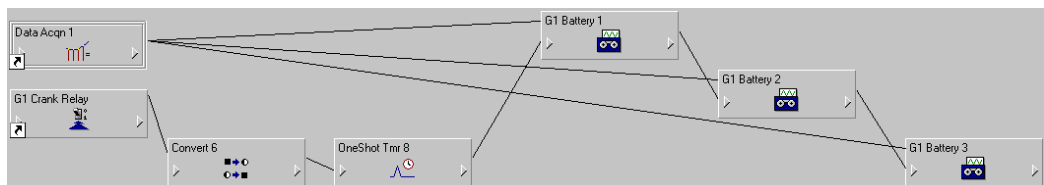

The types of module used are:

- Data Acquisition
- Digital Input
- Convert
- OneShot Timer
- Waveform Recorder

See the following descriptions for the way each module works in this framework.

Refer to *ION Reference* for details on how each module operates and for setting module parameters.

## Data Acquisition – Data Acqn 1

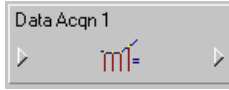

The V4 signal from the meter goes to the Data Acquisition module.

## Digital Input – G1 Crank Relay



This module accepts the Cranking Relay signal from the field. When the signal goes high, the logic to record the battery voltage triggers.

The Input mode can be set to Pulse or KYZ, as explained next.

### Pulse Input Mode

When the Crank Relay signal goes high, a pulse is generated on the Trigger output register, labeled "G1 Crank Relay." The setup registers for the Digital Input module are shown next.

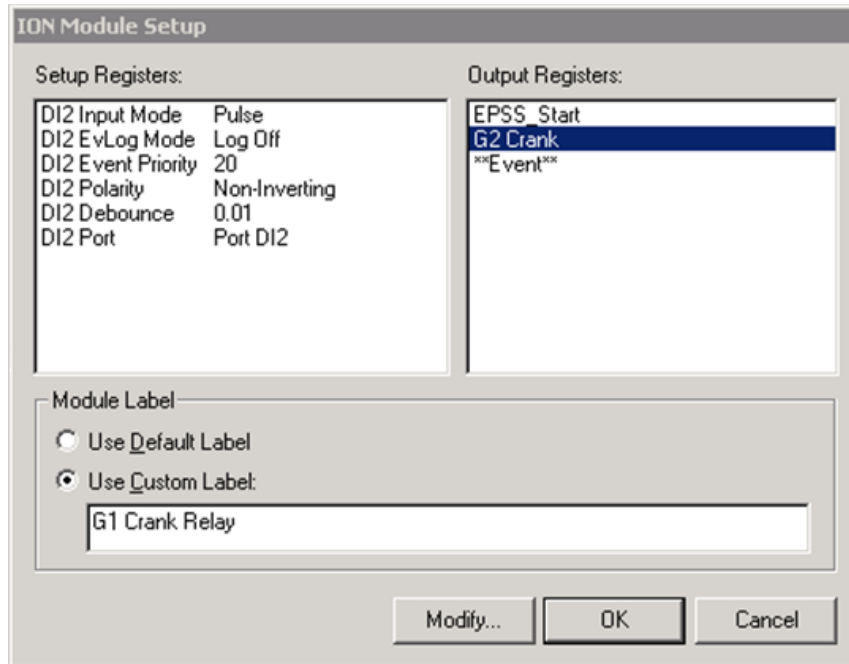

Note that the **Input Mode** value is Pulse. The Trigger output can now be fed into the first Waveform Recorder along with V4 from the Data Acquisition module.

### KYZ Input Mode

If you are using the same Digital Input to handle the Generator Start signal (EPSS\_Start) it is probably set to KYZ mode.

Input Mode KYZ means that a pulse is generated on the Trigger output register when the Crank Relay signal goes high AND when it goes low. The Convert module and One Shot Timer module (explained later) prevent triggering the downstream logic twice.

The Crank Relay Module is setup like this:

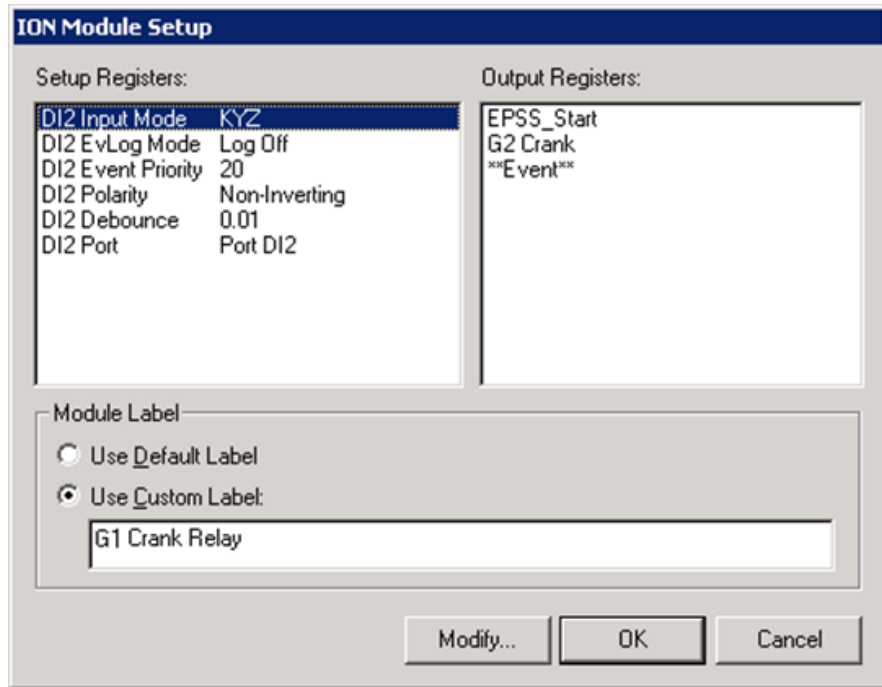

Note that the Input Mode value is KYZ.

### Convert

The signal from the Digital Input module cannot be fed directly into the One Shot Timer. The Convert module converts the digital signal to analog for the One Shot Timer.



### One-Shot Timer

To prevent triggering the downstream logic twice, send the state (EPSS\_Start) from the Convert module into the One Shot Timer:



Send the output register into the first Waveform Recorder G1 Battery 1.

## First Waveform Recorder – G1 Battery 1

The Data Acquisition module and G2 Crank Relay module are the inputs to the first Waveform Recorder, labeled “G1 Battery 1.”

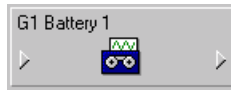

These are the setup registers for the module:

ION Module Setup	
Setup Registers:	Output Registers:
WR8 Depth            100 WR8 RecordMode    Circular WR8 Format           16x96 WR8 Record Delay Cycles 95	WR8 Wform Log WR8 Log State WR8 Records Left WR8 Record Complete **Event**
Module Label	
<input type="radio"/> Use Default Label <input checked="" type="radio"/> Use Custom Label:	
<input type="text" value="G1 Battery 1"/>	
<input type="button" value="Modify..."/> <input type="button" value="OK"/> <input type="button" value="Cancel"/>	

Note the following about the setup registers:

- Depth must be non-zero – 100 is a good number.
- Record Mode should be Circular.
- Format should 16x96. This means 16 samples per cycle and 96 cycles, so at 60 Hz this results in approximately 1.6 seconds worth of data.
- Record Delay Cycles is set to 95 to allow the “window of observation” to move so that only post-event data is captured. Refer to *ION Reference* for more details.

### Second and Third Waveform Recorders

The second Waveform Recorder - G1 Battery 2 - is cascaded with the first to capture another 1.6 seconds of the battery voltage signature. Do this by using the Record Complete output register on G1 Battery 1 as a flag to trigger G1 Battery 2 to start recording.

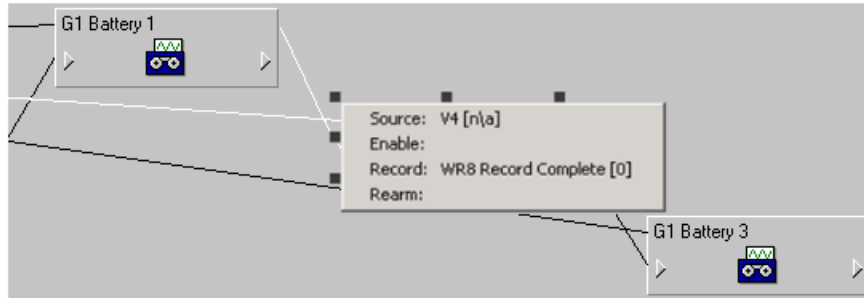

The third Waveform Recorder - G1 Battery 3 - is cascaded with the second recorder to capture the final 1.6 seconds of the battery voltage signature. As above, use the Record Complete output register on G1 Battery 2 as a flag to trigger G1 Battery 3 to start recording.

The Setup Registers should be the same as first waveform recorder with different labels.

## Battery Health Waveform Capture Results

After the framework is complete, in Vista you should see the voltage signature that looks similar to the illustration shown next.

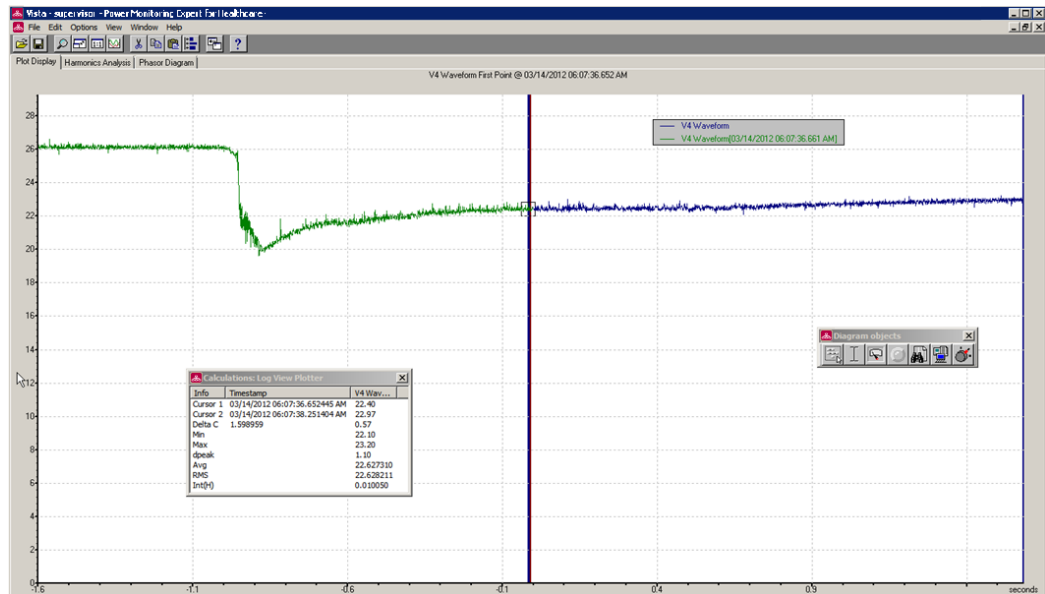

After you obtain this type of result, you can configure the generator in the Generator Performance Configuration Tool and define the Battery Health Report in the Power Monitoring Expert 8.1 Healthcare Edition Power Monitoring Expert - Data Center Edition Web Applications Reports feature. Refer to these sections for instructions on these tasks.

- ["Edit Generator Properties" on page 92](#) if the system does not include the EPSS.
- ["Edit Generator Properties" on page 92](#).
- ["Edit Generator Properties" on page 43](#), if the system includes the EPSS.
- ["Configuring and Running the Battery Health Report" on page 115](#).

## Generator Battery Health Report

The **Generator Battery Health Report** shows the captured waveform image of the generator voltage when the generator starts.

The waveform image includes a reference waveform that shows the initial voltage signature when the batteries were first installed and tested. The reference waveform helps compare the current battery condition to their initial condition.

Research has indicated that when a battery begins to fatigue, the waveform for the voltage during start-up changes. The voltage waveform can be captured and stored in the system for ongoing analysis.

By capturing the voltage waveform when the batteries are in a known good condition, subsequent waveforms can be compared to it to identify changes. In the Generator Battery Health report, you can compare waveform images to see the changes over time. Adverse changes in the waveform indicate a degradation of battery condition.

### **WARNING**

#### **INACCURATE REPORT RESULTS**

- Do not incorrectly configure the devices and software. This can lead to inaccurate reports and/or data results.
- Do not rely solely on system reports to determine if the system is functioning correctly or meeting all applicable standards and requirements.
- Use system reports as a supplement to proper workplace practices or equipment maintenance, not as a substitute.

**Failure to follow these instructions can result in death, serious injury, or equipment damage.**

## Prerequisites

In the Generator Performance Configuration Tool (with or without the EPSS), define the following tabs and fields in order to generate the report:

### **Generators Tab**

- **Name** - The generator entity needs a name.
- **Electrical Data** - The measurement source, nameplate rating, and unit of measurement are required.
- **Status Measurements** - The source of the status measurement and the start, run, and stop values must be selected. Configure the meters that provide these measurements.
- **Evaluation Method** - "Load" is default, but this may be changed to accommodate customer requirements.
- **Battery Waveforms** - Select the source and the measurement. Configure the meters that provide these measurements. Also, configure the frameworks as described in "[Generator Battery Health](#)" on page 106.

For instructions on completing this tab, see the following:

- "Edit Generator Properties" on page 92 if the system does not include the EPSS.
- "Edit Generator Properties" on page 92.
- "Edit Generator Properties" on page 43, if the system includes the EPSS.

After these required items are defined, the report can be configured and generated, as described next.

## Configuring and Running the Battery Health Report

Use the Reports module in Web Applications to configure and generate the Battery Health Report.

**NOTE:** Emergency Power Supply System (EPSS) is a North American term used in the healthcare segment. "EPSS Group" refers to the "Groups" defined in the Generator Performance Configuration Utility.

1. Complete the fields to define the report:
  - **Title** - Enter a name for the report.
  - **Select EPSS (Generator) Group** - Select the generator group for which the report is intended. The list shows the groups that include generators that can record the battery voltage waveform via ION 7550 / ION 7650 meter. See "Edit Generator Properties" on page 92 for more details about selecting the battery waveform selection for a generator. When you select a group in the list, the field to the right shows the devices included in the group.
  - **Exclude Sources** - Click this to define the sources to exclude from the report.

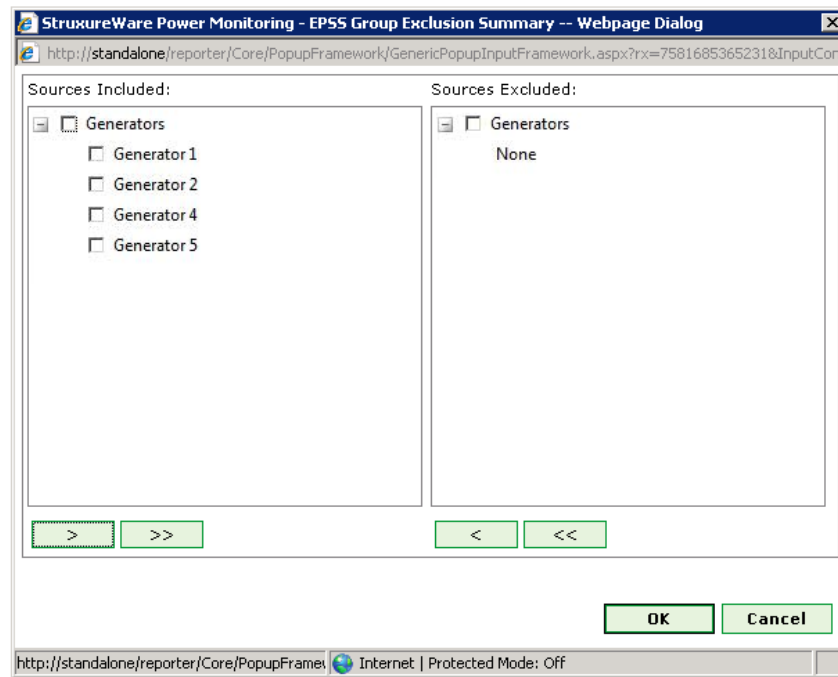

- a. In the **Sources Included** area, select sources to exclude and then click **>** to move those sources to the **Sources Excluded** area.
  - b. To move all of the sources into the **Sources Excluded** area, click **>>**.
  - c. Click **OK** to save the sources and return to the report template. The devices in the group will appear in the **Sources** section of the generated report. Excluded devices will appear as grayed-out entries.
- **Select Generator Starts** - Select the option to specify the start records. If you click **Select Reference Starts** you can choose the specific start records by generator and date. For example, you can use this option to compare yesterday's Gen 1 start voltage signature to the Gen 1 start voltage signature from six months prior.

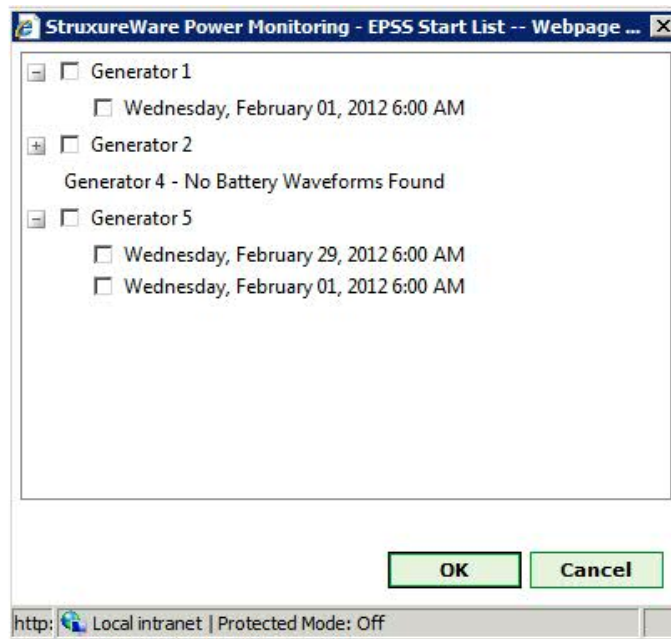

- **Include Data Warnings** - Click **Yes** to include the data warnings in the report. If there are no data warnings, the section is not included in the report. Click **No** to exclude this section.
  - **Cumulative Degradation Threshold** - Enter the value that represents the maximum total voltage difference between the reference waveform and the evaluated waveforms. For example, if the waveform is off by 1.0 on each point from the reference, the total degradation is 10. If the threshold value is 8, then the degradation exceeds the threshold.
2. Click **Generate Report** to produce the report.

## Battery Health Report Example

In this example, the starting voltage waveform (blue) is very similar to the reference waveform (red). The drop to 20 VDC is the point at which the generator started. After the start, battery voltage rises to normal state of charge after the start.

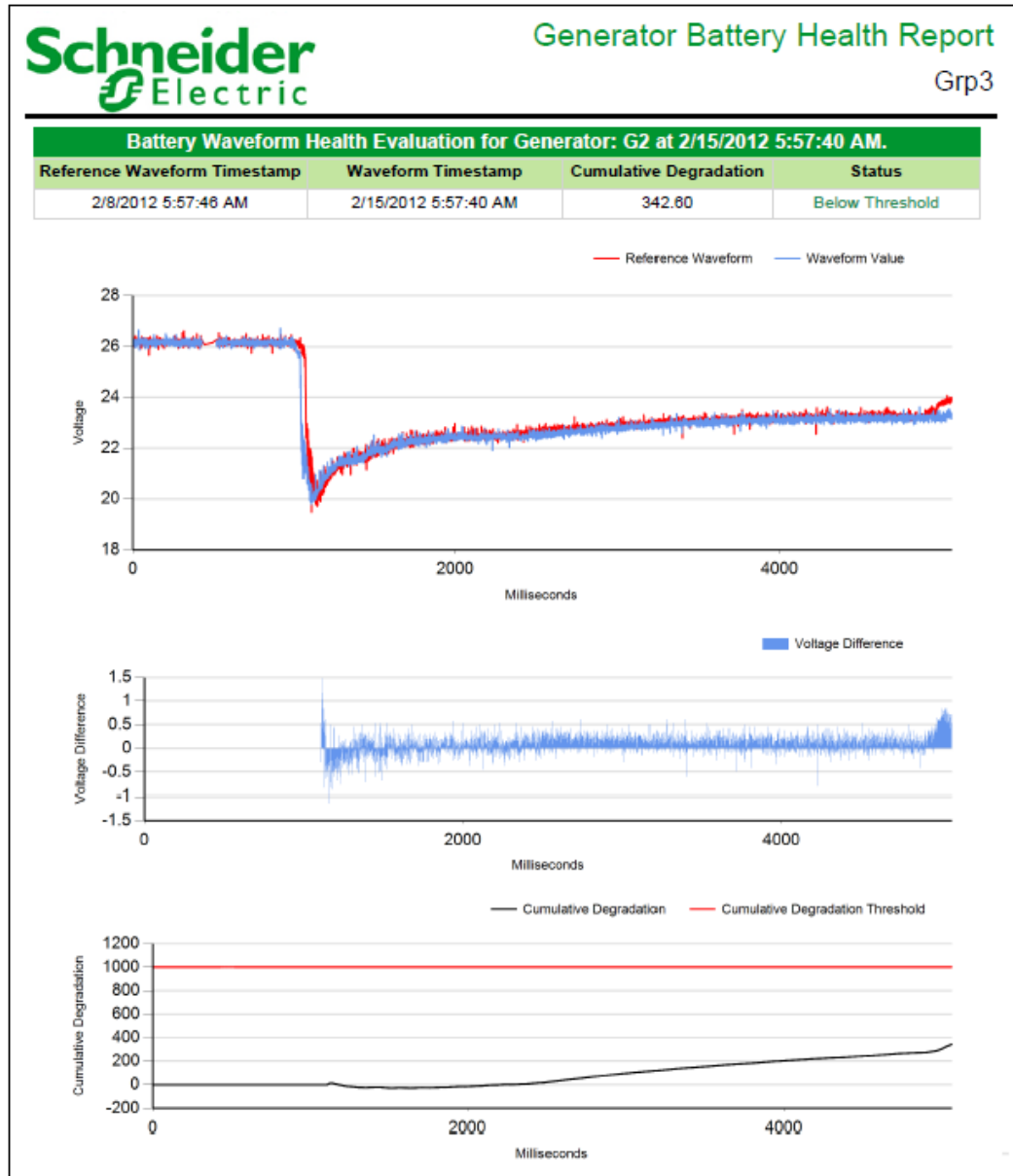

## Generator Battery Health Export

The **Generator Battery Health Export** report is based on the same data as the graphic-based report. The export version provides the raw data in CSV file format. The export file can be imported by other systems, such as Energy Operation.

## Configure and Run the Generator Battery Health Export

Use the Power Monitoring Expert 8.1 Healthcare Edition Power Monitoring Expert - Data Center Edition Web Application Reports feature to configure and produce the Generator Battery Health Export file.

1. In the Reports Library, expand the **Generator Performance** expand the Healthcare Reports folder and click **Generator Battery Health Export**. The report template appears.

### Generator Battery Health Export

<b>Title</b>	<input type="text" value="Generator Battery Health Export"/>
	<input type="text" value="ATS-B Initiated G1,G2,G4,G5"/> <span style="margin-left: 10px;">G2, G4, G5</span> <a href="#">Exclude Sources</a>
<b>Select an EPSS Group and Generator Starts</b>	<input type="text" value="Select Reference Starts"/> <input checked="" type="radio"/> Show the most recent starts <input type="radio"/> Select the generator starts <input type="text" value="5"/> Starts
<b>Cumulative Degredation Threshold</b>	<input type="text"/>

2. Complete the fields to define the report.
  - **Title** - Enter a name for the export file.
  - **Select EPSS Group** - Select the generator group for which the report is intended. The list shows the groups that include generators that can record the battery voltage waveform via ION 7650 meter. For more details about selecting the battery waveform selection for a generator, see:
    - For Generator Performance Configuration Tool, see "[Edit Generator Properties](#)" on page 92.
    - For Generator Performance Configuration Tool with EPSS Test Module, see "[Edit Generator Properties](#)" on page 43.
  - When you select a group in the list, the field to the right shows the devices included in the group.
  - **Exclude Sources** - Click this to define the sources to exclude from the report.

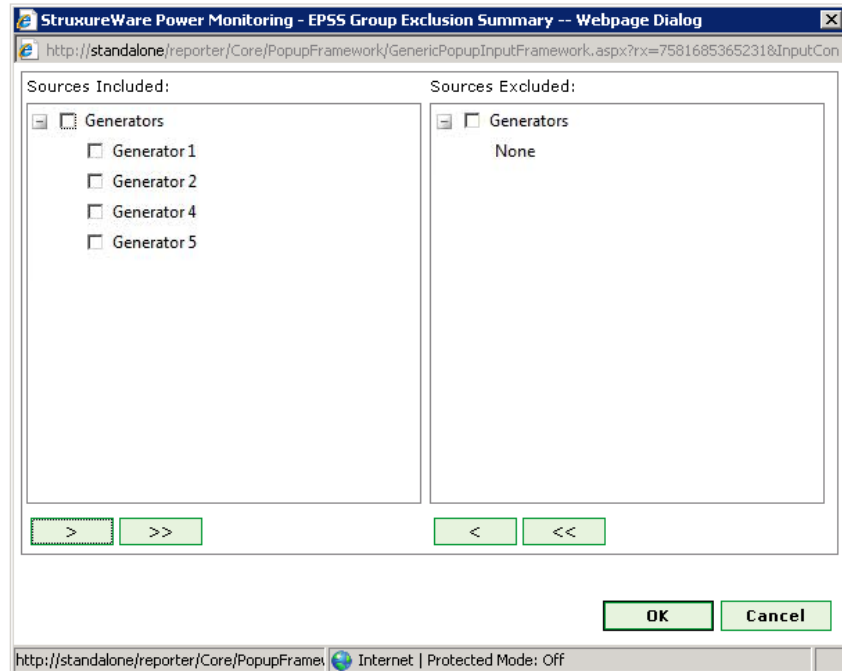

- a. In the **Sources Included** area, select sources to exclude and then click **>** to move those sources to the **Sources Excluded** area.
  - b. To move all of the sources into the **Sources Excluded** area, click **>>**.
  - c. Click **OK** to save the sources and return to the report template. The devices in the group will appear in the **Sources** section of the generated report. Excluded devices will appear as grayed-out entries.
- **Select Generator Starts** - Select the option to specify the start records. If you click **Select Reference Starts** you can choose the specific start records by generator and date. For example, you can use this option to compare yesterday's Gen 1 start voltage signature to the Gen 1 start voltage signature from six months prior.

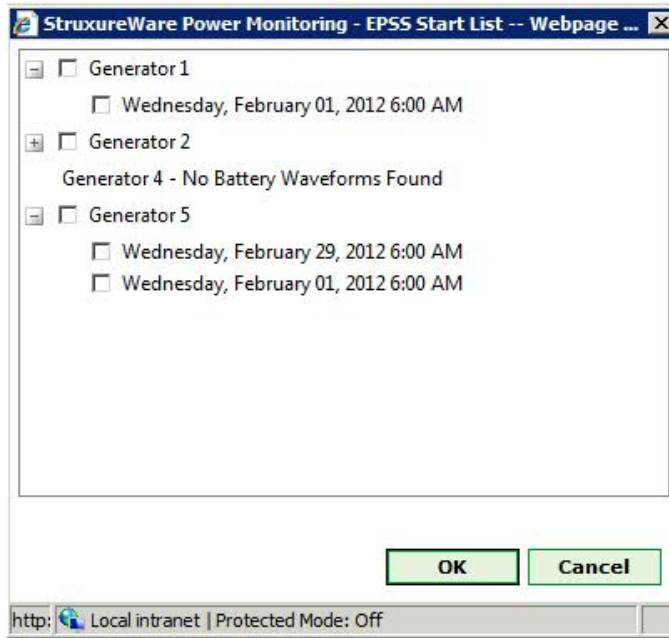

- **Cumulative Degradation Threshold** - Enter the value that represents the maximum total voltage difference between the reference waveform and the evaluated waveforms. For example, if the waveform is off by 1.0 on each point from the reference, the total degradation is 10. If the threshold value is 8, then the degradation exceeds the threshold.

3. Click **Generate Report** to produce the report.

## Battery Health Export Example

	A	B	C	D	E	F	G	H	I	J	K	L	M	N
1	2	G1	2012-02-22T15:06:57	733	2012-02-29T15:11:02	187	0	1000	2839.898804	1256	2939.623901	99.72509766	80	99.72509766
2	2	G1	2012-02-22T15:06:57	733	2012-02-29T15:11:02	187	0	1000	2839.898804	1256	2939.623901	99.72509766	80	199.4501953
3	2	G1	2012-02-22T15:06:57	733	2012-02-29T15:11:02	187	0	1000	2839.898804	1256	2939.623901	99.72509766	80	299.175293
4	2	G1	2012-02-22T15:06:57	733	2012-02-29T15:11:02	187	0	1000	2839.898804	1256	2939.623901	99.72509766	80	398.9003906
5	2	G1	2012-02-22T15:06:57	733	2012-02-29T15:11:02	187	0	1000	2839.898804	1256	2939.623901	99.72509766	80	498.6254883
6	2	G1	2012-02-22T15:06:57	733	2012-02-29T15:11:02	187	0	1000	2839.898804	1256	2939.623901	99.72509766	80	598.3505859
7	2	G1	2012-02-22T15:06:57	733	2012-02-29T15:11:02	187	0	1000	2839.898804	1256	2939.623901	99.72509766	80	698.0756836
8	2	G1	2012-02-22T15:06:57	733	2012-02-29T15:11:02	187	0	1000	2839.898804	1256	2939.623901	99.72509766	80	797.8007813
9	2	G1	2012-02-22T15:06:57	733	2012-02-29T15:11:02	187	0	1000	2839.898804	1256	2939.623901	99.72509766	80	897.5258789
10	2	G1	2012-02-22T15:06:57	733	2012-02-29T15:11:02	187	0	1000	2839.898804	1256	2939.623901	99.72509766	80	997.2509766
11	2	G1	2012-02-22T15:06:57	733	2012-02-29T15:11:02	187	0	1000	2839.898804	1256	2939.623901	99.72509766	80	1096.976074
12	2	G1	2012-02-22T15:06:57	733	2012-02-29T15:11:02	187	0	1000	2839.898804	1256	2939.623901	99.72509766	80	1196.701172
13	2	G1	2012-02-22T15:06:57	733	2012-02-29T15:11:02	187	0	1000	2839.898804	1256	2939.623901	99.72509766	80	1296.42627
14	2	G1	2012-02-22T15:06:57	733	2012-02-29T15:11:02	187	0	1000	2839.898804	1256	2939.623901	99.72509766	80	1396.151367
15	2	G1	2012-02-22T15:06:57	733	2012-02-29T15:11:02	187	0	1000	2839.898804	1256	2939.623901	99.72509766	80	1495.876465
16	2	G1	2012-02-22T15:06:57	733	2012-02-29T15:11:02	187	0	1000	2839.898804	1256	2939.623901	99.72509766	80	1595.601563
17	2	G1	2012-02-22T15:06:57	733	2012-02-29T15:11:02	187	0	1000	2839.898804	1256	2939.623901	99.72509766	80	1695.32666
18	2	G1	2012-02-22T15:06:57	733	2012-02-29T15:11:02	187	0	1000	2839.898804	1256	2939.623901	99.72509766	80	1795.051768

# Generator Load Summary Report

The **Generator Load Summary Report** provides a summary graph of electrical data during a generator run. The report includes a load curve, minimum-maximum-average load summary, and other electrical details.

This report is only included with the system if the EPSS is not installed.

## WARNING

### INACCURATE REPORT RESULTS

- Do not incorrectly configure the devices and software. This can lead to inaccurate reports and/or data results.
- Do not rely solely on system reports to determine if the system is functioning correctly or meeting all applicable standards and requirements.
- Use system reports as a supplement to proper workplace practices or equipment maintenance, not as a substitute.

**Failure to follow these instructions can result in death, serious injury, or equipment damage.**

## Report Prerequisites

In the Generator Performance Configuration Tool, define the following tabs and fields in order to generate the report.

### Generators Tab

- **Name** - The generator entity needs a name.
- **Electrical Data** - The measurement source, nameplate rating, and unit of measurement are required.
- **Status Measurements** - The source of the status measurement and the start, run, and stop values must be selected. Configure the meters that provide these measurements.
- **Evaluation Method** - "Load" is default, but this may be changed to accommodate customer requirements.

See ["Define Generators" on page 91](#) for instructions on the above settings.

## Configure and Generate the Generator Load Summary Report

Use the Reports module in Web Applications to configure and generate the Generator Load Summary Report.

For more information on generating and managing reports, see the "Reports" section of the Web Applications help file.

**NOTE:** Emergency Power Supply System (EPSS) is a North American term used in the healthcare segment. "EPSS Group" refers to the "Groups" defined in the Generator Performance Configuration Utility.

## Generator Load Summary Report Example

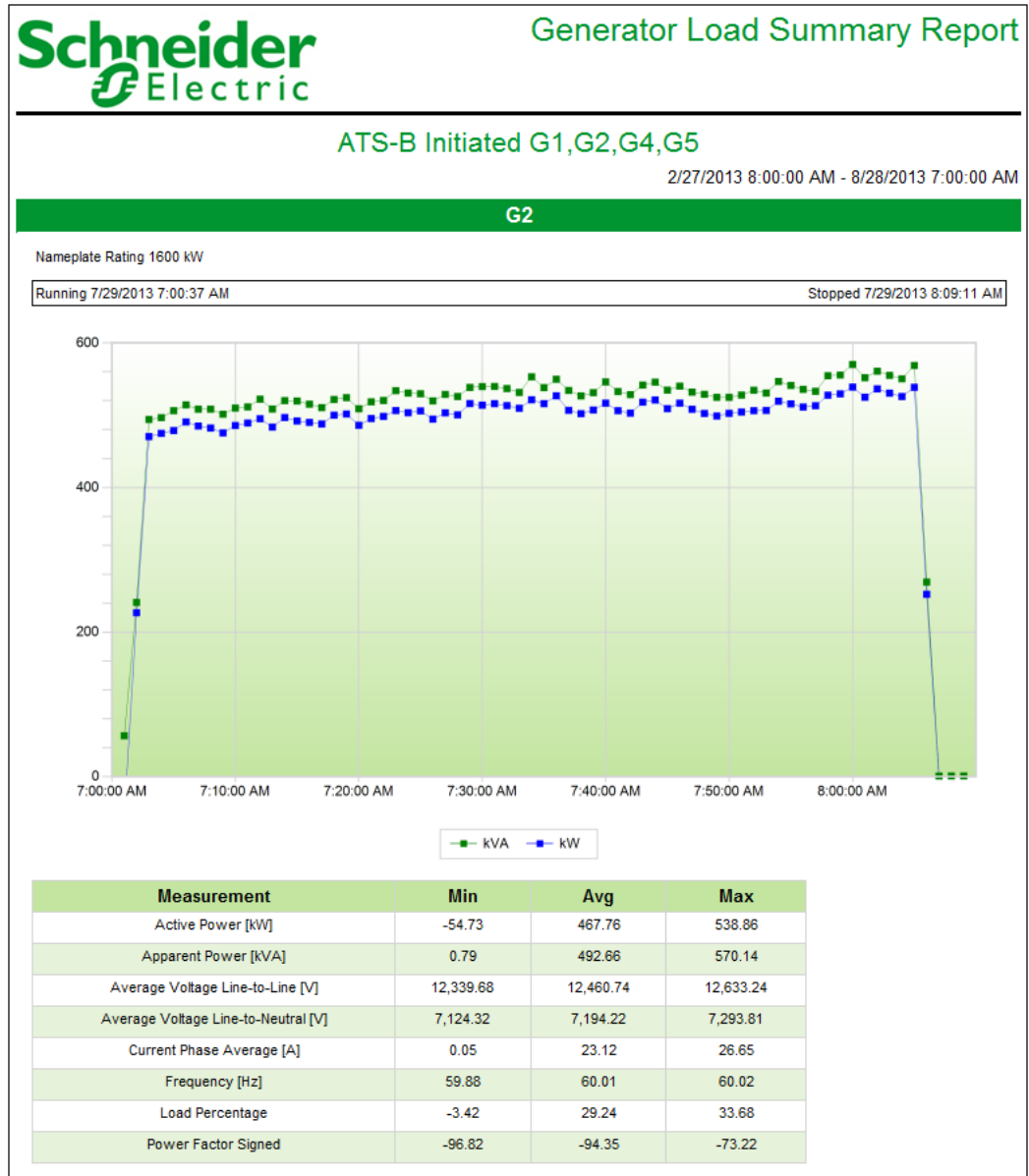



## Generator Load Summary Report

### ATS-B Initiated G1,G2,G4,G5

2/27/2013 8:00:00 AM - 8/28/2013 7:00:00 AM

#### Electrical Details for G2

Nameplate Rating 1600 kW

Running 7/29/2013 7:00:37 AM

Stopped 7/29/2013 8:09:11 AM

Timestamp	kW	kVA	Load %	PFS	I avg	Vll avg	Vln avg	Frequency
7/29/2013 7:01:00 AM	-54.73	56.53	-3.42	-96.82	2.64	12,534.83	7,236.99	59.88
7/29/2013 7:02:00 AM	226.71	240.88	14.17	-94.12	11.49	12,494.25	7,213.56	60.01
7/29/2013 7:03:00 AM	470.29	494.12	29.39	-95.18	23.31	12,445.82	7,185.60	60.01
7/29/2013 7:04:00 AM	474.87	496.57	29.68	-95.63	23.38	12,459.60	7,193.56	60.01
7/29/2013 7:05:00 AM	478.81	506.26	29.93	-94.58	23.88	12,434.85	7,179.26	60.01
7/29/2013 7:06:00 AM	490.59	514.21	30.66	-95.41	24.19	12,449.52	7,187.74	60.01
7/29/2013 7:07:00 AM	484.94	508.25	30.31	-95.41	23.89	12,467.79	7,198.28	60.02
7/29/2013 7:08:00 AM	482.31	508.36	30.14	-94.88	23.90	12,451.94	7,189.13	60.01
7/29/2013 7:51:00 AM	504.39	527.84	31.52	-95.66	24.78	12,473.35	7,201.50	60.01
7/29/2013 7:52:00 AM	508.23	534.55	31.64	-94.70	25.11	12,457.29	7,192.22	60.01
7/29/2013 7:53:00 AM	508.58	530.68	31.66	-95.46	24.88	12,480.67	7,205.72	60.01
7/29/2013 7:54:00 AM	519.32	546.56	32.46	-95.02	25.53	12,497.70	7,215.55	60.01
7/29/2013 7:55:00 AM	515.66	541.11	32.23	-95.30	25.30	12,496.31	7,214.75	60.01
7/29/2013 7:56:00 AM	511.40	535.62	31.96	-95.48	25.10	12,490.05	7,211.13	60.01
7/29/2013 7:57:00 AM	513.06	533.16	32.07	-96.23	24.93	12,509.28	7,222.24	60.01
7/29/2013 7:58:00 AM	527.68	554.73	32.98	-95.12	26.01	12,468.06	7,198.44	60.01
7/29/2013 7:59:00 AM	529.43	555.54	33.09	-95.30	25.93	12,500.62	7,217.24	60.01
7/29/2013 8:00:00 AM	538.86	570.14	33.68	-94.51	26.65	12,466.28	7,197.41	60.01
7/29/2013 8:01:00 AM	524.81	551.78	32.80	-95.11	25.84	12,465.62	7,197.03	60.01
7/29/2013 8:02:00 AM	536.41	560.83	33.53	-95.64	26.28	12,462.86	7,195.44	60.01
7/29/2013 8:03:00 AM	530.49	555.05	33.16	-95.58	25.99	12,474.76	7,202.31	60.01
7/29/2013 8:04:00 AM	525.79	550.30	32.86	-95.55	25.80	12,467.89	7,198.34	60.01
7/29/2013 8:05:00 AM	538.57	568.77	33.66	-94.69	26.28	12,633.24	7,293.81	59.97
7/29/2013 8:06:00 AM	252.21	269.19	15.76	-93.69	12.51	12,531.39	7,235.00	59.95
7/29/2013 8:07:00 AM	-0.58	0.79	-0.04	-73.22	0.05	12,339.68	7,124.32	59.98
7/29/2013 8:08:00 AM	-0.60	0.81	-0.04	-74.03	0.05	12,339.84	7,124.41	59.98
7/29/2013 8:09:00 AM	-0.62	0.83	-0.04	-74.58	0.05	12,339.95	7,124.47	59.98

## Generator Test Report

The Generator Test Report shows the run details and overall status for generators and transfer switches in the group. For example, the report shows the transfer time of the lead ATS and indicates whether the transfer time passes or does not pass the test requirements.

Use the Reports module in Web Applications to configure and generate the Generator Test Report.

For more information on generating and managing reports, see the "Reports" section of the Web Applications help file.

## Report Prerequisites

In the Generator Performance Configuration Tool, define the following tabs and fields in order to generate the report.

### Generators Tab

- **Name** - Enter a name for the generator entity.
- **Electrical Data** - Enter the measurement source, nameplate rating, and unit of measurement.
- **Status Measurements** - Enter the source of the status measurement and the start, run, and stop values. Configure the meters that provide these measurements.
- **Evaluation Method** - "Load" is default, but you can change this to accommodate customer requirements.

See ["Define Generators" on page 91](#) for instructions on the above settings.

### Groups Tab

- **Name** - Enter a name for the group entity.
- Select at least one entity from the **Generators**, **Transfer Switches**, or **Equipment** lists. The group can contain entities from each list combined.

See ["Define Groups" on page 95](#) for instructions.

After these required items are defined, the report can be configured and generated, as described next.

# Power Capacity

Power Capacity let you manage and report on generator and UPS systems, and report on branch circuits within a data center facility.

Power Capacity includes the following configuration tools:

- ["Generator Power Configuration Utility" on page 126](#)
- ["UPS Power Configuration Utility" on page 135](#)

Power Capacity includes the following reports:

- ["Branch Circuit Power Report" on page 125](#)
- ["Generator Power Report" on page 134](#)
- ["UPS Power Report" on page 142](#)

## Branch Circuit Power Report

The Branch Circuit Power Report is used by data center facility operators to generate a report that describes the average and maximum loading for branch circuits within the data center facility, as well as the percentage load compared to the breaker size. This section describes the procedures involved in creating a report, how the reports are used, examples of the generated report, and the managing and saving of the report.

---

**NOTE:** This report requires a license to be used. Contact your Schneider Electric representative for more information.

---

The Branch Circuit Power Report is used for:

- Proactive capacity management
  - Incident investigation
  - Customer expansion planning
  - Service Level Agreement (SLA) management
- 

**NOTE:** For the Branch Circuit Power Report to provide accurate information, devices must be installed, configured, and communicating correctly, you must use and correctly configure the **Circuit > Rack > Customer** hierarchy, and the Managed Circuits feature run each time a device configuration change is made. If any of these tasks are not performed correctly, your reports will provide inaccurate information. See "Switching to the Customer Circuit hierarchy template" section in the *Power Monitoring Expert 8.1 – Data Center Edition Commissioning Guide* for more information.

---

## Branch Circuit Power Report example

The Branch Circuit Power Report data depends on the selections you make while configuring the report and the contents of the Power Monitoring Expert or Data Center database.

**Branch Circuit Power**  
Facility 1  
Victoria, British Columbia

8/6/2015 12:00:00 AM - 8/7/2015 12:00:00 AM (Server Local)

**Data Warnings**

No data warnings.

Customer	Rack	Branch Circuit	Breaker Size (A)	Avg Loading (A)	Avg Loading (kW)	Avg Loading (%)	Max Loading (A)	Max Loading (kW)	Max Loading (%)
Customer 1	R10A	Bus01_PIU04_01	20	0.0**	0.0**	0**	0.0**	0.0**	0**
Customer 1	R11A	Bus01_PIU04_02	20	0.0**	0.0**	0**	0.0**	0.0**	0**
Customer 1	R12A	Bus01_PIU04_03	20	0.0**	0.0**	0**	0.0**	0.0**	0**
Customer 1	R10A	Bus02_PIU04_01	30	0.0**	0.0**	0**	0.0**	0.0**	0**
Customer 1	R11A	Bus02_PIU04_02	20	0.0**	0.0**	0**	0.0**	0.0**	0**
Customer 1	R12A	Bus02_PIU04_03	20	0.0**	0.0**	0**	0.0**	0.0**	0**
Customer 1	R12A	Bus03_PIU04_03	20	0.0**	0.0**	0**	0.0**	0.0**	0**

\* Value estimated  
\*\* Value based on incomplete data  
\*\*\* Expected value missing

Generated on: 8/6/2015 12:56:20 PM Page 1 of 1

## Generator Power Configuration Utility

The Generator Power Configuration Utility lets you create, edit, and manage one or more generator systems that will be used for reporting on the power capacity of those systems.

The Generator Power Configuration Utility window consists of a single panel that contains a grid area and an editor area. The grid area is empty initially but will be populated with entries you create through the editor area. Use the editor area to define the settings for new items, or to update the settings for an item that you select in the grid area.

The generator system is the logical system configuration that will be used for reporting power capacity.

This configuration utility allows you to create, edit, and manage one or more generator systems that will be used for reporting on the power capacity of those systems.

For information on generator redundancy types, see ["Generator System Redundancy Types" on page 266](#).

## Generator Configuration Restrictions

The configuration tool enforces certain rules when creating a generator system, group, or generator:

- **Generator System**
  - Name must be unique.

- One or more systems are allowed.
- **Generator Groups**
  - Name must be unique.
  - At least one group must be present in each system.
  - All groups are connected to the same load.
  - For N, N+1, and N+2 system types:  
Only one group is allowed.  
  
Each generator in the group must have the same nameplate rating (kVA) value.  
Each generator in the group must have the same derated nameplate rating (kW) value.
  - For 2N, 2(N+1) and 2(N+2) system types:  
Up to three groups are allowed.  
  
All groups must have the same number of generators.  
  
All generators in the groups must have the same nameplate rating (kVA) value.  
  
All generators in the groups must have the same derated nameplate rating (kW) value.
- **Generators**
  - Name must be unique.
  - At least one generator must be present in each group.
  - A maximum of 12 generators is allowed in each group.

## Define generator systems

The generator system is the logical system configuration that will be used for reporting power capacity.

The following image is an example of the Generator Power Configuration Utility with a sample generator system selected.

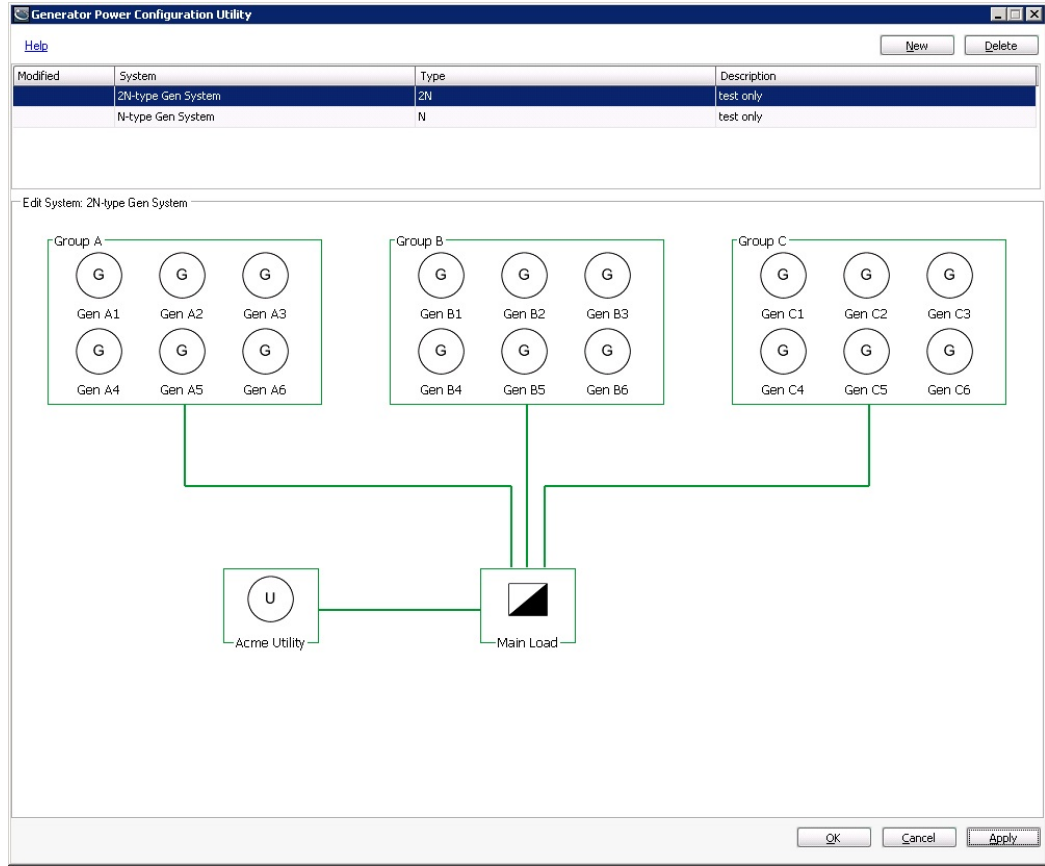

Control	Description
<b>Help</b>	Opens the help for the utility.
<b>New</b>	Creates a new entry in the grid.
<b>Delete</b>	Deletes the selected entry from the grid.
<b>OK</b>	Saves all changes and exits the utility.
<b>Cancel</b>	Exits the utility without saving changes.
<b>Apply</b>	Saves all changes and leaves the utility open.

Grid Area Columns	Description
<b>Modified</b>	Displays a status symbol for the record.
+ (plus)	A new entry.
* (asterisk)	An existing entry has been modified.
! (exclamation mark)	The entry is incorrect.
<b>System</b>	Displays the system name.
<b>Type</b>	Displays the Generator system type (N, 2N, N+2, etc)
<b>Description</b>	Displays a description of the system

To start the Generator Power Configuration Utility, either:

- Double-click the **Generator Power Configuration Utility** icon located in the **Power Monitoring Expert DC Ed** folder on the desktop,
- or
- Click **Start > All Programs > Schneider Electric > Power Monitoring Expert DC Ed > Generator Power Configuration Utility**.

To define a new generator system:

1. Click **New**. The Edit System: New System area appears below the grid.

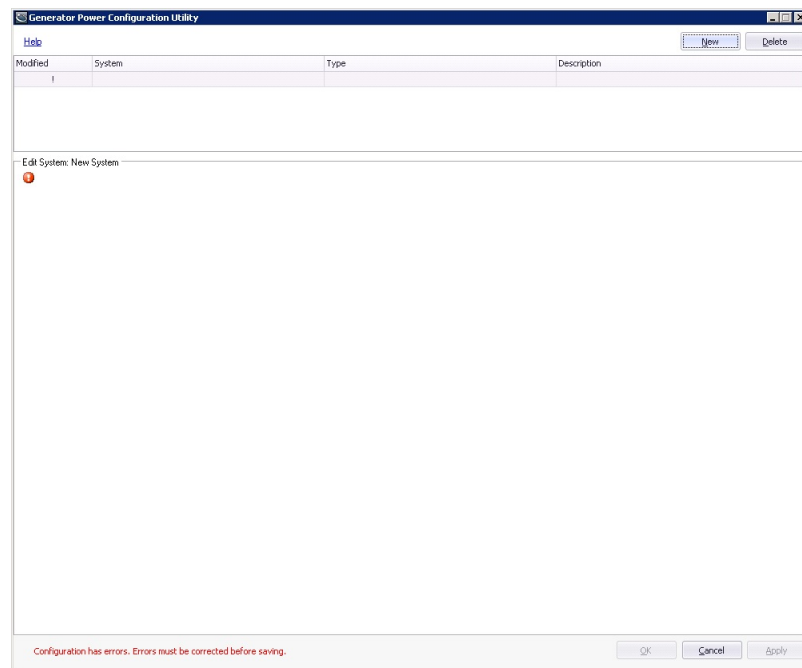

2. Click anywhere in the editor area. The Properties screen appears.

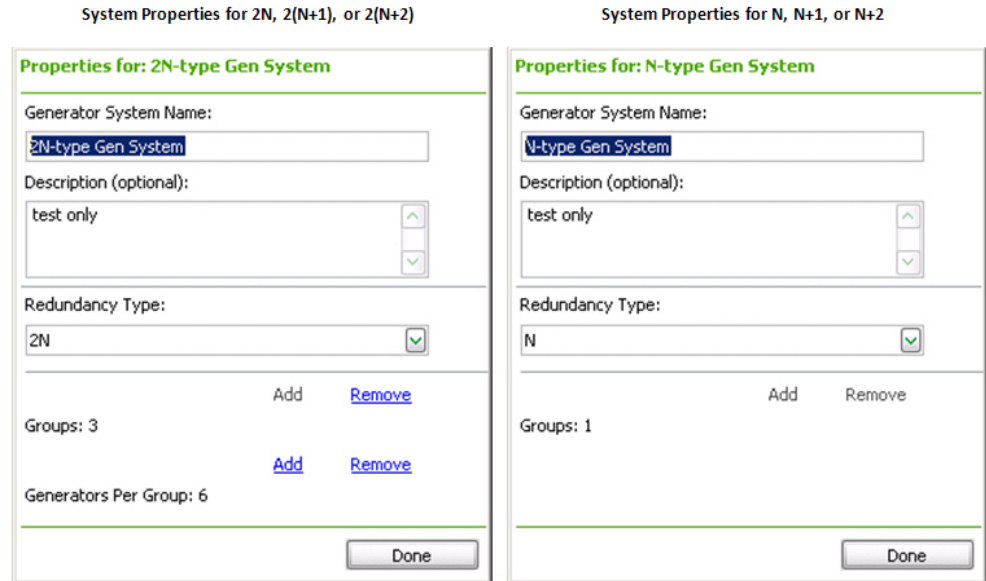

3. Complete the details for the generator system:
  - a. **Generator System Name:** Enter a name for the generator system. Each generator system must have a unique name.
  - b. **Description:** Enter a description for the generator system. This field is optional.
  - c. **Redundancy Type:** Select the redundancy type for the generator system. The different redundancy types are explained in "[Generator System Redundancy Types](#)" on page 266.
  - d. **Groups:** Shows the number of generator groups contained in the generator system. Click **Add** to add groups to the generator system. Click **Remove** to delete groups.
  - e. **Generators Per Group:** Shows the number of generators in each generator group in the system. Click **Add** to add generators to the group. Click **Remove** to delete generators.
 

This property is only available when the system redundancy type is 2N, 2(N+1) or 2(N+2). To define the number of generators for a system with redundancy type N, N+1 or N+2, use the generator group properties. See "[Define Generator Groups](#)" on page 131 for more information.
4. Click **Done** to save the generator system.

Once complete, you can configure the other components of the system:

["Define Generator Groups"](#)

["Define Generators"](#)

["Define Generator Loads"](#)

["Define Generator Utilities"](#)

## Define Generator Groups

A generator group represents a logical grouping of generators. The system contains at least one group and can contain multiple groups. Depending on the system type, the group properties may be different, as shown below. See "[Generator Configuration Restrictions](#)" on page 126 for more information.

To define the properties for a generator group:

1. Click on the group object border. The Properties screen appears.

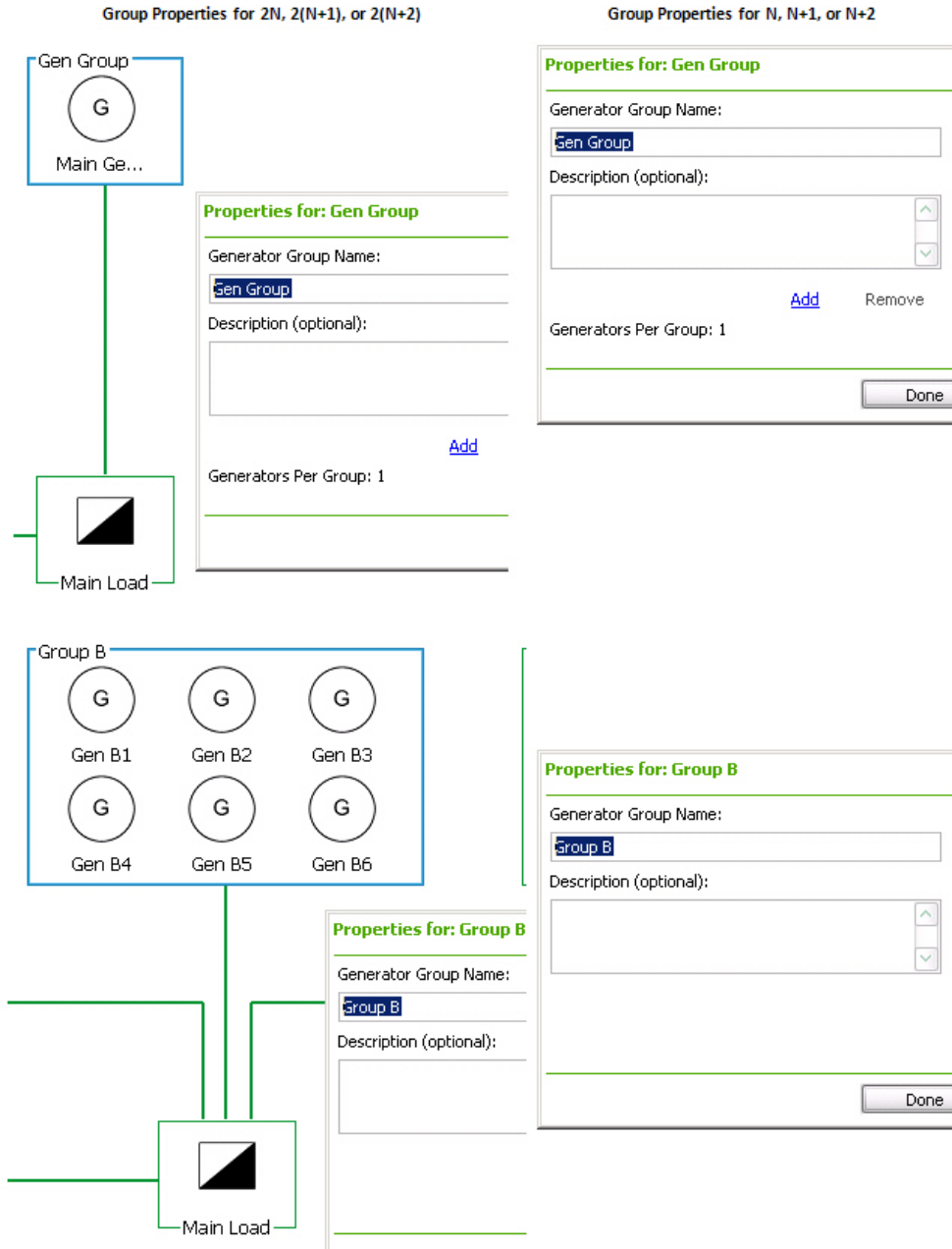

2. Complete the details for the generator group:

- a. **Generator Group Name:** Enter a name for the group.

Each generator group must have a unique name.

- b. **Description:** Enter a description for the group. This field is optional.
- c. **Generators Per Group:** Click **Add** to increase the number of generators in the group. Click **Remove** to decrease the number. This property is available only for system redundancy types N, N+1 or N+2.

3. Click **Done** to save the generator group.

## Define Generators

A generator represents an actual generator device in the data center. A group contains at least one generator and can contain multiple generators. For some system types, each group must contain the same number of generators. See ["Generator Configuration Restrictions" on page 126](#) for more information.

To define a generator:

1. Click on the generator object border. The selected generator will be highlighted in blue and the Properties screen appears.

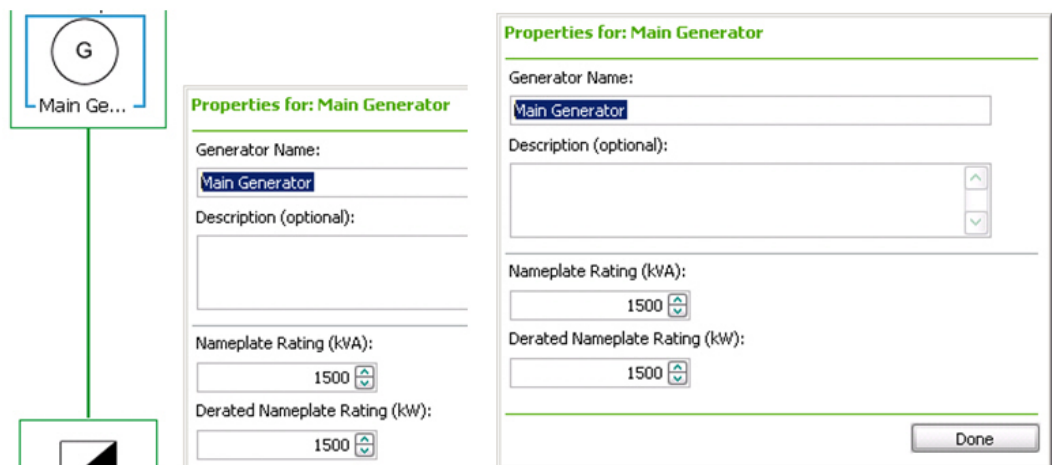

2. Complete the details for the generator:
  - a. **Generator Name:** Enter the name for the generator.  
This name must be unique for each generator in the system.
  - b. **Description:** Enter a description for the generator. This field is optional.
  - c. **Nameplate Rating (kVA):** Enter the maximum output power (kVA) of the generator.  
This value must be greater than zero.
  - d. **Derated Nameplate Rating (kW):** Enter the maximum power capacity (kW) that the generator is expected to support. This value must be equal or less than the nameplate rating value, and greater than zero.
3. Click **Done** to save the generator.

## Define Generator Loads

A generator load represents the logical load attached to a generator group. Each generator system must have only one load.

To define a generator load:

1. Click the generator load element in the system diagram. The Properties screen appears.

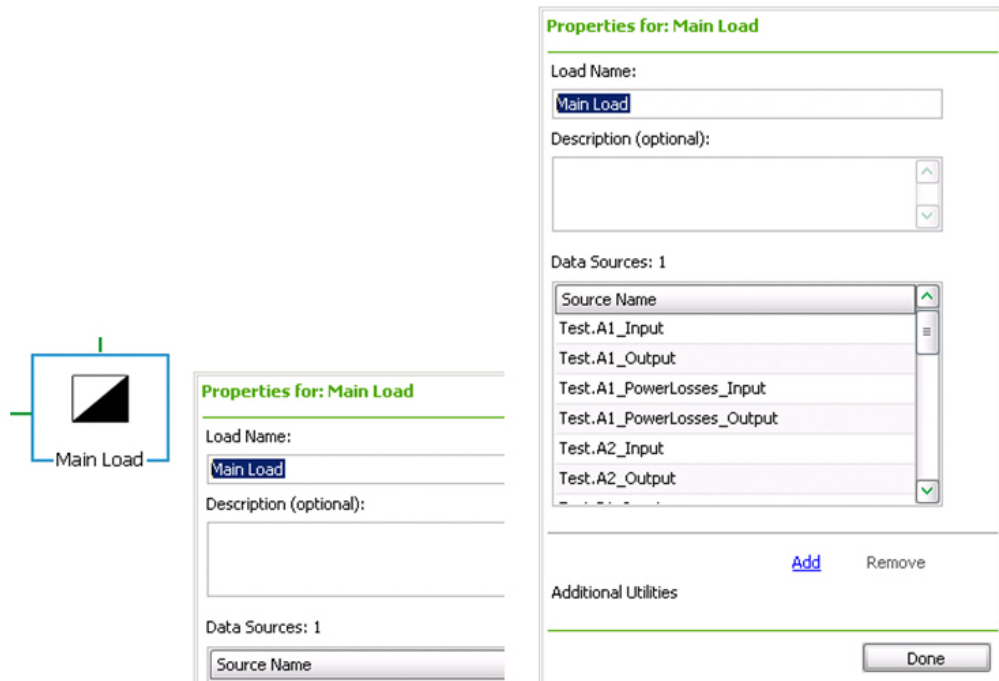

2. Complete the details for the generator load:
  - a. **Load Name:** Enter a name for the load.
  - b. **Description:** Enter a description for the load. This field is optional.
  - c. **Data Source:** Select one or more meter sources where load data is logged for this load.
  - d. **Additional Utilities:** Click **Add** to increase the number of utility objects for the load. Click **Remove** to decrease the number of utility objects.
3. Click **Done** to save the generator load.

## Define Generator Utilities

A utility represents the logical utility provider that feeds a particular load under normal operation. This logical utility has no functional purpose in the calculations for power redundancy. It is used to provide a more complete diagram representation for the generator system. A system may have one or two utilities represented in the diagram.

To define a utility:

1. Click the utility element in the diagram. The Properties screen appears.

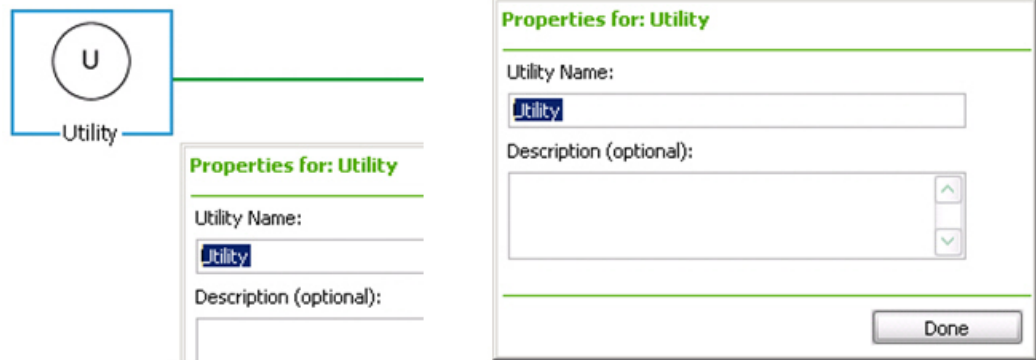

2. Complete the details for the utility:
  - a. **Utility Name:** Enter a name for the utility.
  - b. **Description:** Enter a description for the utility. This field is optional.
3. Click **Done** to save the utility.

Once the configuration of the generators, loads, and utilities are complete, click **Apply** to save, or click **OK** to save the configuration and exit the utility.

## Generator Power Report

The Generator Power Report provides information regarding the generator backup power system and its ability to handle a utility power outage while still complying with the intended redundancy design. The report is generated after a representation of your backup generator system is created and configured using the Generator Power Configuration Utility.

---

**NOTE:** This report requires a license to be used. Contact your Schneider Electric representative for more information.

---

The Generator Power Report data depends on the selections you make while configuring the report and the contents of the Power Monitoring Expert database. See "[Generator Power Capacity Measurements](#)" on page 134 for more details on the Generator Power Report data.

For more information on generating and managing reports, see the "Reports" section of the Web Applications help file.

## Generator Power Capacity Measurements

The Generator Power Report uses a priority table to determine which measurement to use for querying power data for a load.

The table is stored in the Power Monitoring Expert database, and consists of a list of measurement IDs with a priority value for each measurement. When the report is querying for data, it iterates through the measurement list according to the priority and queries the database for load data. Once data is found, it is returned in the report.

By default, the table GEN\_CapacityMeasurement holds four known measurements:

Priority	Measurement ID	Measurement Name
1	116	Active Power Sliding Window Demand Delivered
2	107	Active Power Sliding Window Demand Delivered-Received
3	128	Active Power Mean
4	193	Active Power

Measurement ID	Devices Found
116	ION7650
107	ION7650, Modbus devices: BCPM, CM2000, CM3000, CM4000, Micrologic A and E (for CompactNSX breakers), EM5600, Micrologic E, H, P (for Masterpact breakers), PM1200 and PM800
128	ION7650
193	Modbus devices: CM2000, CM3000, CM4000, Micrologic A and E (for CompactNSX breakers), EM5600, Micrologic E, H, P (for Masterpact breakers), PM1200, PM800, Sepam40 series and Sepam 80 series

## UPS Power Configuration Utility

The UPS Power Configuration Utility lets you create, edit, and manage one or more UPS systems that will be used for reporting on the power capacity of those systems. The UPS Power window contains a grid area and an editor area. The grid area is initially empty but will be populated with entries you create. The editor area displays the configuration diagrams and allows you to define and modify the configurations.

The UPS system consists of UPS groups, modules, and loads. The configuration utility provides a way to organize the components of the system graphically and define properties for each component.

For information on UPS redundancy types, see ["UPS System Redundancy Types" on page 270](#).

## UPS Power Configuration Restrictions

The configuration tool enforces certain rules when you creating UPS systems, groups and modules:

- **UPS System**
  - Name must be unique.
  - One or more systems are allowed.
- **UPS Groups**
  - Name must be unique.
  - At least one group must be present in each system.
  - A maximum of three groups are allowed in each system.
  - For N, N+1, and N+2 system types:
    - Each group in the system may have a different number of UPS modules.

Each UPS module in the group must have the same nameplate rating (kVA) value.

Each UPS module in the group must have the same derated nameplate rating (kW) value

Each group is connected to one load only. No other group can be connected to the same load.

- For 2N, 2(N+1) and 2(N+2) system types:

All groups must have the same number of UPS modules.

All UPS modules in the groups must have the same nameplate rating (kVA) value.

All UPS modules in the groups must have the same derated nameplate rating (kW) value.

Depending on the number of groups present in the system, a load may be shared by two groups. See the "[UPS Power Configuration Utility](#)" on [page 135](#) for more information.

- **UPS Modules**

- Name must be unique.
- At least one module must be present in each group.
- A maximum of 12 modules is allowed in each group.

## Define UPS Systems

The UPS system is the logical system configuration that will be used for reporting power capacity.

The following image is an example of the UPS Power Configuration Utility with a sample generator system selected.

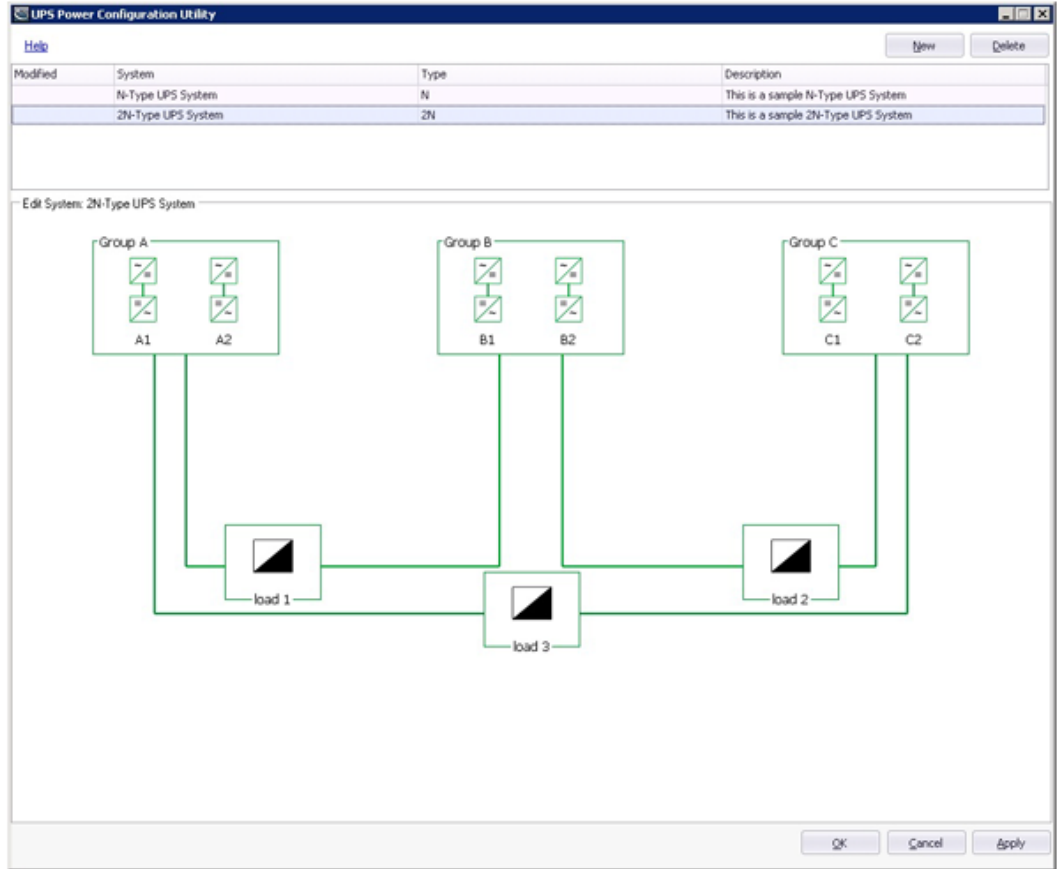

Control	Description
Help	Opens the help for the utility.
New	Creates a new entry in the grid.
Delete	Deletes the selected entry from the grid.
OK	Saves all changes and exits the utility.
Cancel	Exits the utility without saving changes.
Apply	Saves all changes and leaves the utility open.

Grid Area Columns	Description
Modified	Displays a status symbol for the record.
+ (plus)	A new entry.
* (asterisk)	An existing entry has been modified.
! (exclamation mark)	The entry is incorrect.
System	Displays the system name.
Type	Displays the UPS system type (N, 2N, N+2, etc)
Description	Displays a description of the system

To start the UPS Power Configuration Utility:

- Double-click the **UPS Power Configuration Utility** icon in the **Power Monitoring Expert DC Ed** folder located on the desktop,
- or
- Click **Start > All Programs > Schneider Electric StruxureWare Power Monitoring Expert DC Ed > UPS Power Configuration Utility**.

To define a new UPS system:

1. Click **New**. The Edit System: New System area appears below the grid.

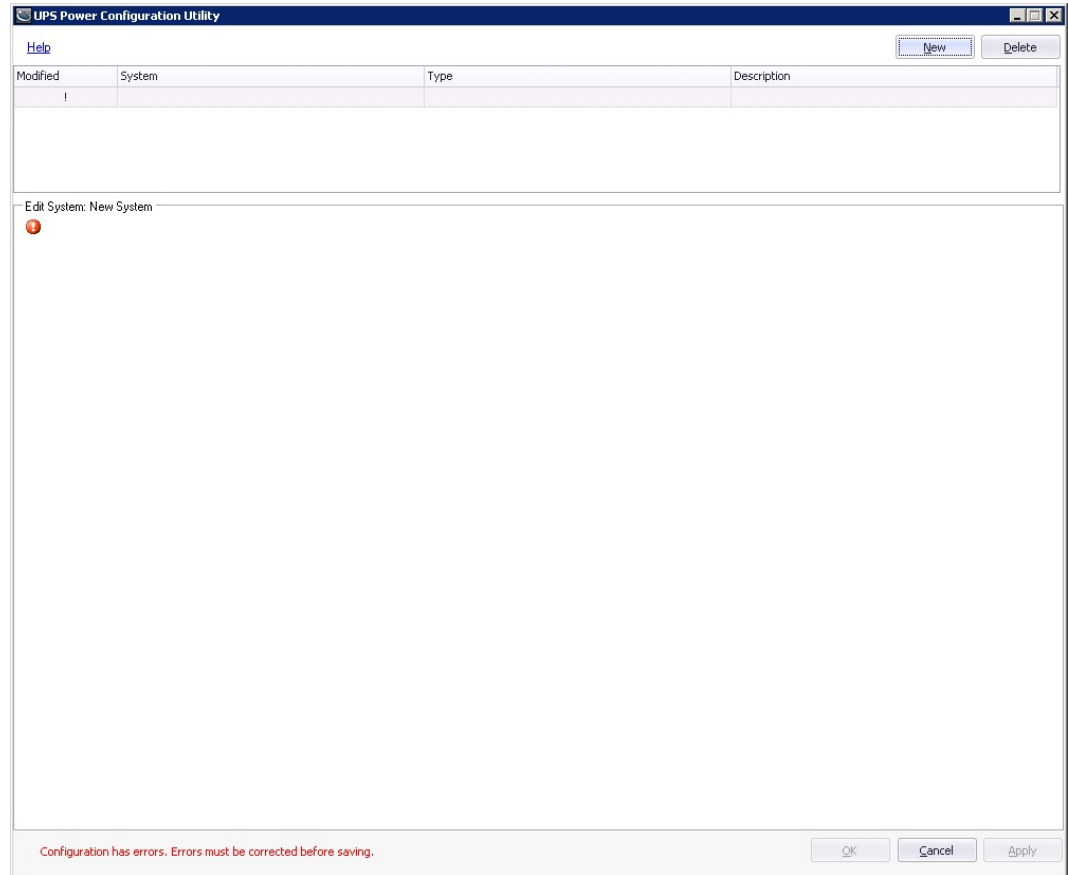

2. Click anywhere in the editor area. The Properties screen appears.

System Properties for 2N, 2(N+1), or 2(N+2)

**Properties for: 2N-Type UPS System**

System Name:

Description (optional):

Redundancy Type:

Add    [Remove](#)

Groups: 3  
[Add](#)    [Remove](#)

Modules Per Group: 2

System Properties for N, N+1, or N+2

**Properties for: N-Type UPS System**

System Name:

Description (optional):

Redundancy Type:

Add    [Remove](#)

Groups: 2

3. Complete the details for the UPS system:
  - a. **System Name:** Enter a name for the UPS system. Each UPS system must have a unique name.
  - b. **Description:** Enter a description for the UPS system. This field is optional.
  - c. **Redundancy Type:** Select the redundancy type for the UPS system. The different redundancy types are explained in "[UPS System Redundancy Types](#)" on page 270.
  - d. **Groups:** Shows the number of UPS groups contained in the UPS system. Click Add to add groups to the UPS system. Click **Remove** to delete groups.
  - e. **Modules Per Group:** Shows the number of UPS modules in each group in the system. Click Add to add UPS modules to the group. Click Remove to delete modules. This property is only available when the system redundancy type is 2N, 2(N+1) or 2(N+2). To define the number of modules for a system with redundancy type N, N+1 or N+2, use the UPS group properties. See "[Define UPS loads](#)" on page 142 for more information.
4. Click **Done** to save the UPS system.

Now you can configure the other components of the system:

["Define UPS groups"](#)

["Define UPS modules"](#)

["Define UPS loads"](#)

## Define UPS groups

A UPS group represents a logical grouping of UPS modules. The system contains at least one group and can contain multiple groups. Depending on the system type, the group properties may be different, as shown below. See "UPS Power Configuration Restrictions" on page 135 for more information.

To define the properties for a UPS group:

1. Click on the group object border. The Properties screen appears.

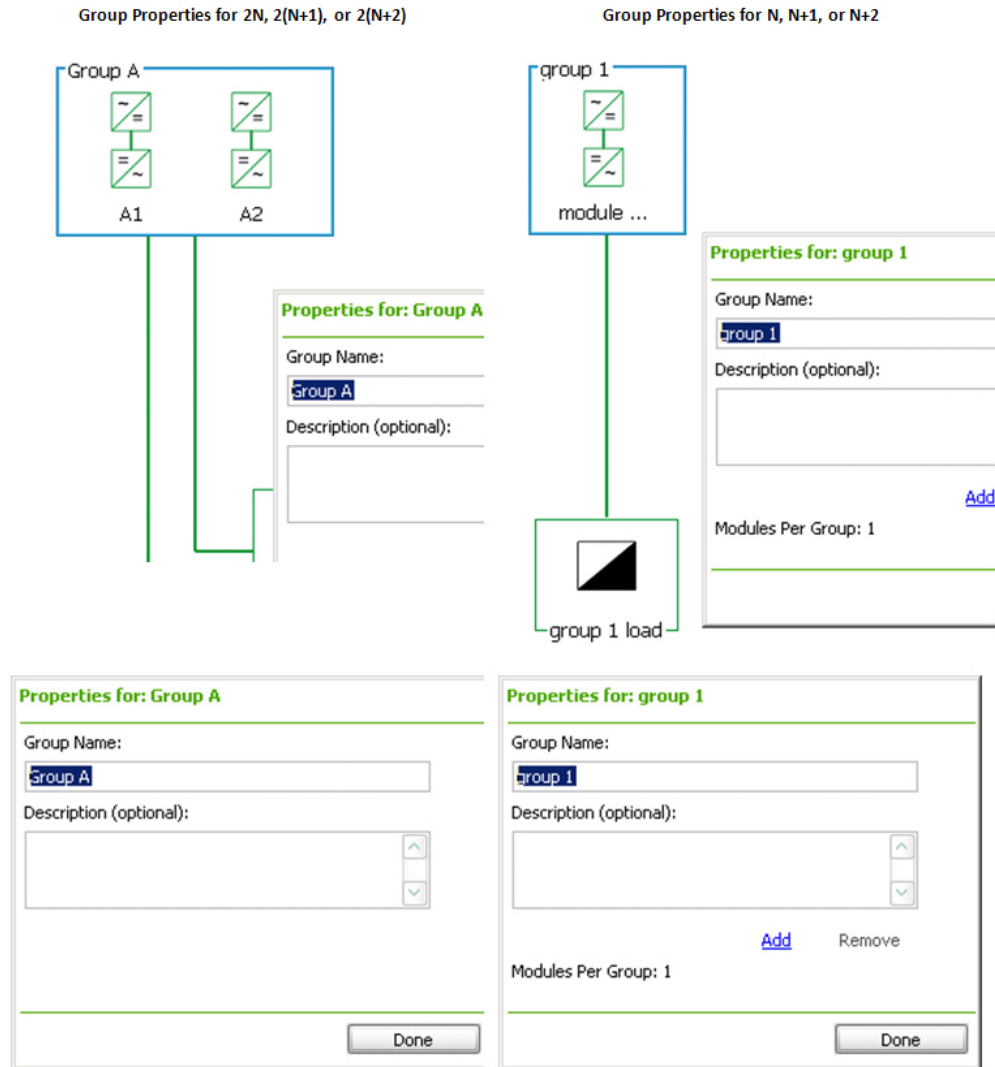

2. Complete the details for the UPS group:
  - a. **Group Name:** Enter a name for the group. Each UPS group must have a unique name.
  - b. **Description:** Enter a description for the group. This field is optional.
  - c. **Modules Per Group:** Click **Add** to increase the number of UPS modules in the group. Click **Remove** to decrease the number. This property is available only for system redundancy types N, N+1 or N+2.

3. Click **Done** to save the UPS group.

## Define UPS modules

A UPS module represents an actual UPS device in the data center. A group contains at least one UPS module and can contain multiple modules. For some system types, each group must contain the same number of UPS modules. See "[UPS Power Configuration Restrictions](#)" on page 135 for more information.

To define a UPS module:

1. Click on the module object border. The selected module will be highlighted in blue and the Properties screen appears.

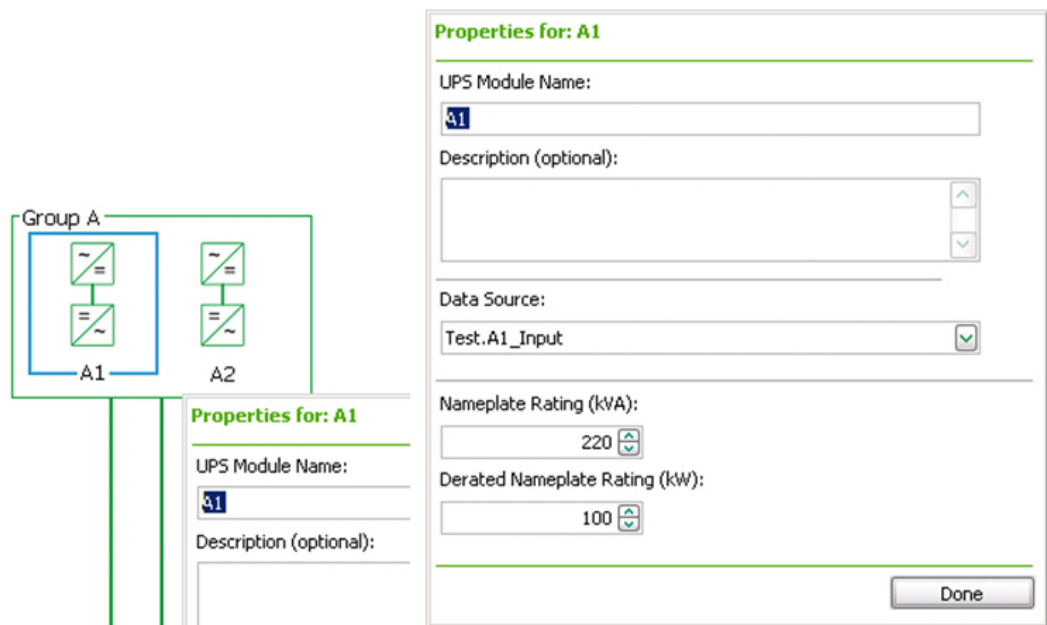

2. Complete the details for the UPS module:
  - a. **UPS Module Name:** Enter the name for the module. This name must be unique for each UPS module in the system.
  - b. **Description:** Enter a description for the module. This field is optional.
  - c. **Data Source:** Select the meter source in Power Monitoring Expert where load data is logged for the UPS module. The source must be unique for each UPS module.
  - d. **Nameplate Rating (kVA):** Enter the maximum output power (kVA) of the UPS module. This value must be greater than zero.
  - e. **Derated Nameplate Rating (kW):** Enter the maximum power capacity (kW) that the UPS module is expected to support. This value must be equal or less than the nameplate rating value, and greater than zero.
3. Click **Done** to save the UPS module.

## Define UPS loads

A UPS load represents the logical load attached to a UPS group. This logical load has no functional purpose in the calculations for power redundancy. The UPS load is used only to provide a more complete diagram representation for the UPS system.

To define a UPS load:

1. Click the UPS load element in the system diagram. The Properties screen appears.

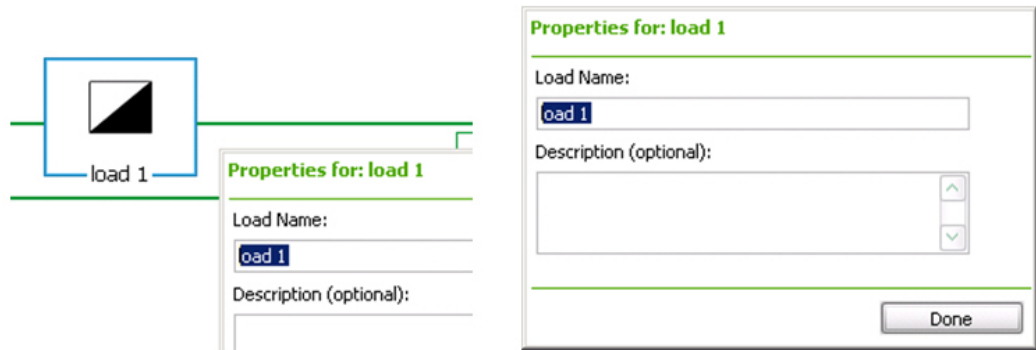

2. Complete the details for the UPS load:
  - a. **Load Name:** Enter a name for the load.
  - b. **Description:** Enter a description for the load. This field is optional.
3. Click **Done** to save the UPS load.

## UPS Power Report

The UPS Power Report data depends on the selections you make while configuring the report and the contents of the Power Monitoring Expert database. See "[UPS Power Report Capacity Measurements](#)" on page 142 for more details on report data.

---

**NOTE:** This report requires a license to be used. Contact your Schneider Electric representative for more information.

---

For more information on generating and managing reports, see the "Reports" section of the Web Applications help file.

## UPS Power Report Capacity Measurements

The UPS Power Report uses a priority table to determine which measurement to use for querying power data for a UPS module.

The table is stored in the Power Monitoring Expert database, and consists of a list of measurement IDs with a priority value for each measurement. When the report is querying for data, it iterates through the measurement list according to the priority and queries the database for load data. Once data is found, it is returned in the report.

By default, the table GEN\_CapacityMeasurement holds four known measurements:

Priority	Measurement ID	Measurement Name
1	116	Active Power Sliding Window Demand Delivered
2	107	Active Power Sliding Window Demand Delivered-Received
3	128	Active Power Mean
4	193	Active Power

Measurement ID	Devices Found
116	ION7650
107	ION7650, Modbus devices: BCPM, CM2000, CM3000, CM4000, Micrologic A and E (for CompactNSX breakers), EM5600, Micrologic E, H, P (for Masterpact breakers), PM1200 and PM800
128	ION7650
193	Modbus devices: CM2000, CM3000, CM4000, Micrologic A and E (for CompactNSX breakers), EM5600, Micrologic E, H, P (for Masterpact breakers), PM1200, PM800, Sepam 40 series and Sepam 80 series

# Power Efficiency

The Power Efficiency features help you manage and report on monitoring devices that make up the power loss system, and report on branch PUE and average power consumed for the IT equipment running in a data center facility.

System Efficiency includes the following configuration tool:

- ["Power Losses Configuration Utility" on page 144](#)

System Efficiency includes the following reports:

- ["Power Losses Report" on page 148](#)
- ["Power Usage Effectiveness \(PUE\) Summary Report" on page 150](#)

## Power Losses Configuration Utility

The Power Losses Configuration Utility allows you to create, edit, and manage the different logical sources, such as transformers or UPS modules monitoring devices that make up the power losses system. It is this system that will be used for reporting on its losses.

The Power Losses Configuration Utility window consists of two tabs labeled **Transformers** and **UPS Modules**. Each tab contains a grid area and an editor area. The grid area is empty initially but is populated with entries you create through the editor area. Use the editor area to define the settings for new items, or to update the settings for an item that you select in the grid area.

Before you can generate a Power Losses Report, you need to define a power losses system using the Power Losses Configuration Utility.

The following image is an example of the Power Losses Configuration Utility.

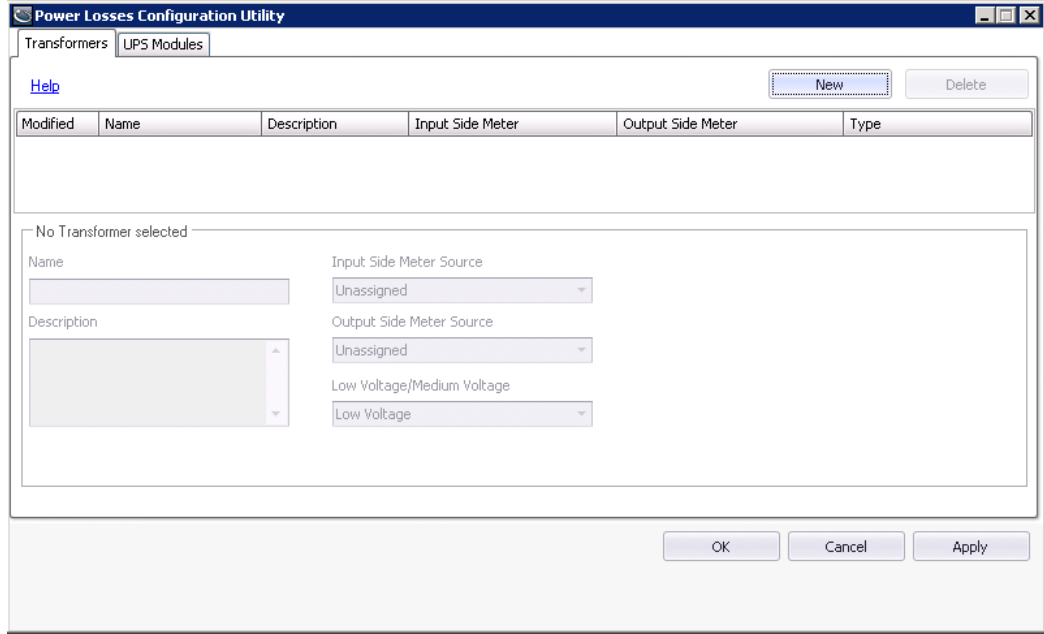

Control	Description
<b>Help</b>	Opens the help for the utility.
<b>New</b>	Creates a new entry in the grid.
<b>Delete</b>	Deletes the selected entry from the grid.
<b>OK</b>	Saves all changes and exits the utility.
<b>Cancel</b>	Exits the utility without saving changes.
<b>Apply</b>	Saves all changes and leaves the utility open.

Grid Area Columns	Description
Modified	Displays a status symbol for the record.
+ (plus)	A new entry.
* (asterisk)	An existing entry has been modified.
! (exclamation mark)	The entry is in error.

## Power Losses Configuration Restrictions

The configuration tool enforces certain rules when you create a power losses system:

- **All Devices**
  - Name must be unique.
  - A meter source must be assigned only once to a particular device.
- **Transformers**
  - Zero, one, or more low voltage transformers may be present in the power losses system.

- Zero, one, or more medium voltage transformers may be present in the power losses system.
- **UPS Modules**
  - Zero, one, or more UPS modules may be present in the power losses system.

## Define the Power Losses components

To start the Power Losses Configuration Utility, either:

- Double-click the **Power Losses Configuration Utility** icon located in the **Power Monitoring Expert DC Ed** folder,
- or
- Click **Start > All Programs > Schneider Electric > StruxurerWare Power Monitoring Expert DC Ed > Power Losses Configuration Utility**.

Select the appropriate tab to define the following power losses components:

["Define Transformers for Power Losses"](#)

["Define UPS modules for Power Losses"](#)

## Define Transformers for Power Losses

To create or update components representing the transformers used in your power losses system:

1. Select the **Transformers** tab.
2. Click **New**. The Edit fields are enabled.

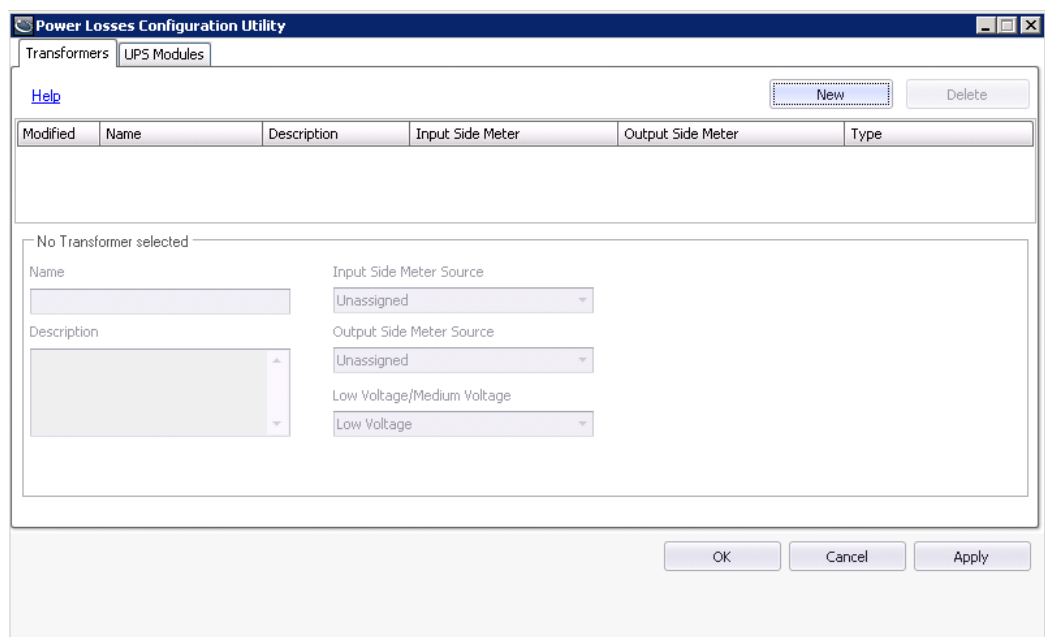

3. Define the transformer:

- a. **Name:** Enter a unique name for the transformer.
- b. **Description:** Enter a description for the transformer (e.g. make, model). This field is optional.
- c. **Input Side Meter Source:** Select a source name from the drop-down list. The source represents the Power Monitoring Expert device that records the electrical data from the input side of the transformer. "[Power Losses Reporting Measurements](#)" on page 148 for more information.
- d. **Output Side Meter Source:** Select a source name from the dropdown list. The source represents the Power Monitoring Expert device that records the electrical data from the output side of the transformer. "[Power Losses Reporting Measurements](#)" on page 148 for more information.
- e. **Low Voltage/Medium Voltage:** Select Low Voltage or Medium Voltage from the drop-down list to indicate the transformer voltage rating type.

The screenshot shows the 'Power Losses Configuration Utility' window with the 'Transformers' tab selected. The window contains a table with the following data:

Modified	Name	Description	Input Side Meter	Output Side Meter	Type
+	Transformer Test		MAIN.DP_1	MAIN.DP_7	Low Voltage

Below the table is an 'Edit: New Transformer' form with the following fields:

- Name: Transformer Test
- Description: (empty text area)
- Input Side Meter Source: MAIN.DP\_1
- Output Side Meter Source: MAIN.DP\_7
- Low Voltage/Medium Voltage: Low Voltage

Buttons for 'New', 'Delete', 'OK', 'Cancel', and 'Apply' are visible.

4. Click **OK** to save the transformer.

## Define UPS modules for Power Losses

To create or update components representing the UPS modules used in your power losses system:

1. Select the **UPS Modules** tab.
2. Click **New**. The Edit fields are enabled.
3. Define the UPS module:
  - a. **Name:** Enter a unique name for the UPS module.
  - b. **Description:** Enter a description for the UPS module (e.g. make, model). This field is optional.

- c. **Input Side Meter Source:** Select a source name from the drop-down list. The source represents the Power Monitoring Expert device that records the electrical data from the input side of the UPS module. ["Power Losses Reporting Measurements" on page 148](#) for more information.
- d. **Output Side Meter Source:** Select a source name from the drop-down list. The source represents the Power Monitoring Expert device that records the electrical data from the output side of the UPS module. ["Power Losses Reporting Measurements" on page 148](#) for more information.

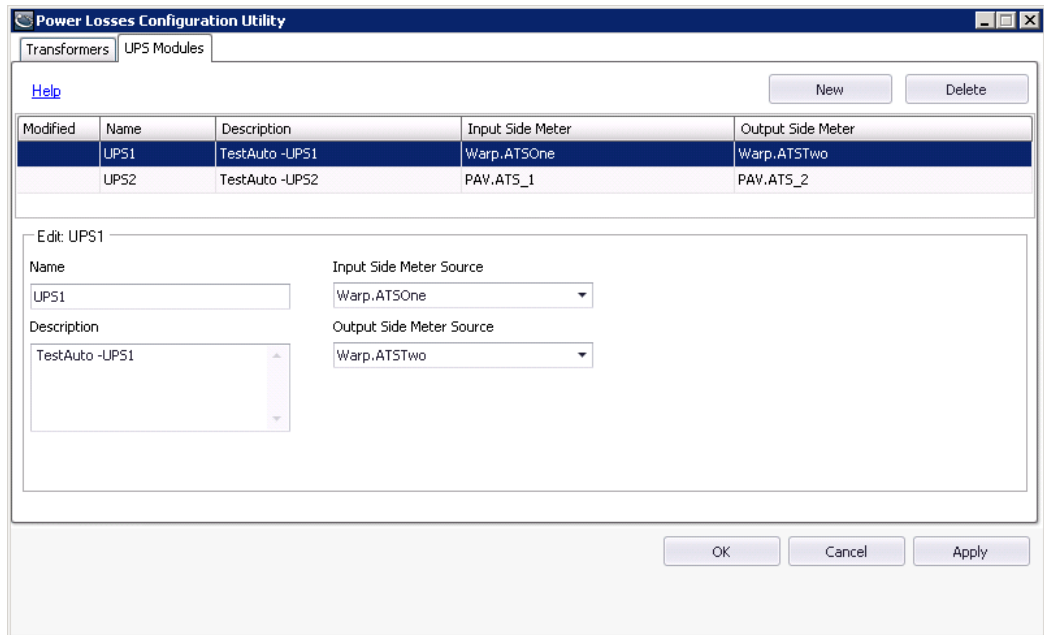

4. Click **OK** to save the UPS module.

## Power Losses Report

The Power Losses Report provides the breakdown of the cost of various losses throughout a Data Center's power system and to lets you analyze and quantify the cost of inefficiencies due to transformers (MV and LV) and UPS modules.

For more information on generating and managing reports, see the "Reports" section of the Web Applications help file.

## Power Losses Reporting Measurements

The Power Losses Report uses a priority table to determine which measurement to use for querying energy and power data for the different devices defined in the power losses system.

The table is stored in the Power Monitoring Expert database, and consists of a list of measurement IDs with a priority value for each measurement. When the report is querying for data, it iterates through the measurement list according to the priority and queries the database for the specific type of data. Once data is found, it is returned in the report.

The report also looks for different types of logical measurements, cataloged in a separate Measurements table.

By default, the table PSL\_PSLMeasurementCategory holds two known measurements:

Category ID	Category Name
1	Power
2	Energy

By default the table PSL\_PSLMeasurementPriorityMapping holds the following information:

Category ID	Physical ID	Priority	(Physical) Measurement Name
1	116	1	Active Power Sliding Window Demand Delivered
1	107	2	Active Power Sliding Window Demand Delivered-Received
1	128	3	Active Power Mean
1	193	4	Active Power
2	129	1	Active Energy Delivered
2	135	2	Active Energy Delivered-Received
3	13	1	Current Phase Average Sliding Window Demand Delivered
3	12	2	Current Phase Average Mean
3	182	3	Current Phase Average

Devices that provide *Power* measurements:

Measurement ID	Devices Found
116	ION7650
107	ION7650, Modbus devices: BCPM, CM2000, CM3000, CM4000, Micrologic A and E (for CompactNSX breakers), EM5600, Micrologic E, H, P (for Masterpact breakers), PM1200 and PM800
128	ION7650
193	Modbus devices: CM2000, CM3000, CM4000, Micrologic A and E (for CompactNSX breakers), EM5600, Micrologic E, H, P (for Masterpact breakers), PM1200, PM800, Sepam 40 series and Sepam 80 series

Devices that provide *Energy* measurements:

Measurement ID	Devices Found
129	ION7650
135	ION7650, Modbus devices: BCPM and Micrologic E (for Masterpact breakers)

Devices that provide *Current Phase Average* measurements:

Measurement ID	Devices Found
13	---
12	ION7650
182	ION7650 Modbus devices: CM2000, CM3000, CM4000, Micrologic A and E (for CompactNSX breakers), DM6200, EM5600, Micrologic E, H, P (for Masterpact breakers), PM1200, PM200, PM700 and PM800

## Power Usage Effectiveness (PUE) Summary Report

The Power Usage Effectiveness (PUE) Summary Report displays PUE and average power consumed for a data center facility, along with average power consumed for the IT equipment running in the facility. Additionally, two graphical trends are displayed in a dashboard that corresponds to the facility PUE values and to the energy consumption of the facility.

**NOTE:** The PUE Report does not require the data center VIP to be configured. See the "VIP" section *Power Monitoring Expert 8.1 – Data Center Edition Commissioning Guide*. However, the framework does provide an example of the aggregation of power for the data center and the IT Load, and the resulting calculation of interval energies that are required for the report to run.

This section provides an overview of the PUE Summary Report and includes:

- Definitions of some of the terms associated with PUE
- PUE Summary Report prerequisites
- Calculations used to generate the PUE Summary Report.

### Terms and Definitions

- **PUE** – Power Usage Effectiveness, defined as a ratio between the total power consumed by a data center facility and the power consumed by the IT equipment that runs in the facility. For example, a PUE value of 2.0 indicates that for every watt of IT equipment power consumed, an additional watt is consumed to operate the facility that houses the equipment (e.g. equipment cooling, power distribution to the equipment).
- **Total Data Center Power** – Represents all the power consumed by the data center facility at one point in time. This value should represent an instantaneous power consumption value.
- **Total Data Center Energy** – Represents all the energy used by the data center facility for a given time interval. This value typically represents a 15-minute energy usage value.
- **Total IT Equipment Power** – Represents all the power consumed by the IT equipment used in a data center facility at one point in time. This value should represent an instantaneous power consumption value
- **Total IT Equipment Energy** – Represents all the energy used by the IT equipment in the data center facility for a given time interval. This value typically represents a 15-minute energy usage value.

- **Support** – Represents the overhead amount of energy or power required to operate the data center, which does not account for IT equipment power consumption. This value represents the data center power distribution losses, as well as the power consumed to cool down the data center facility.

### Prerequisites

Before a PUE Summary Report can be successfully generated, the following prerequisites must be met:

- Power Monitoring Expert – Data Center Edition is installed and operational.
- The proper licensing is obtained for this module.
- Reporter is installed and functional.
- The Power Monitoring Expert database contains Total Data Center Power and Total Data Center Energy data, as well as Total IT Equipment Power and Total IT Equipment Energy, as defined in the previous section.
- The PUE Summary Report Pack is installed and operational.
- **IT Equipment Power Measurement:** Click **Select Measurement** to choose the measurement for instantaneous power consumption for all the IT equipment used.

---

**NOTE:** Confirm that the Data Center source and the IT Equipment source entries are correct before generating a report. If these entries are not correct, the generated report can contain inaccurate information.

---

### PUE Summary Report Example

The sections and content contained in the PUE Summary Report depend on the selections made in the PUE Summary Report template and the contents of the Power Monitoring Expert database. See the following sample report.



**PUE Summary**  
 Category 2  
 Report End Date: 7/25/2014

Reporting Period	Start Date and Time	End Date and Time	PUE	Average Load	
				Data Center	IT Equipment
24 Hours	7/24/2014 12:00:00 AM	7/25/2014 12:00:00 AM	1.99	70 kW	35 kW
7 Days	7/18/2014 12:00:00 AM	7/25/2014 12:00:00 AM	1.98	70 kW	36 kW
30 Days	6/25/2014 12:00:00 AM	7/25/2014 12:00:00 AM	1.94	72 kW	37 kW
12 Months	7/25/2013 12:00:00 AM	7/25/2014 12:00:00 AM	1.83	57 kW	31 kW

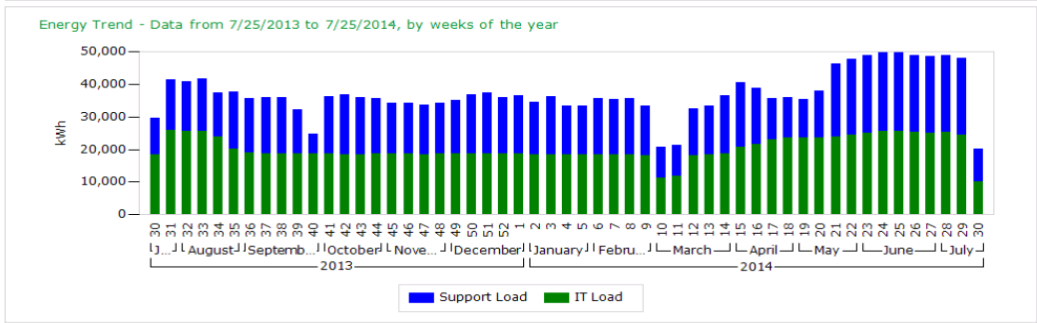
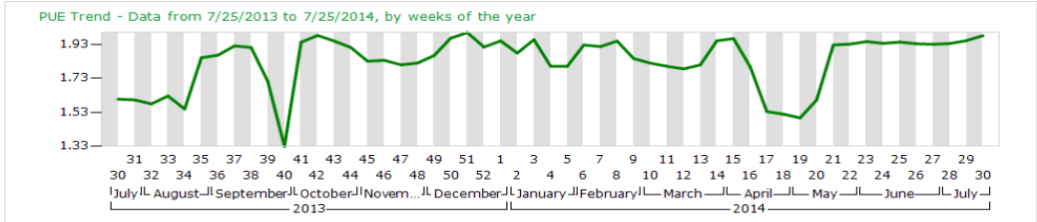

Generated on: 8/2/2015 2:09:38 PM

Page 2 of 2

**PUE Summary Report Calculations**

In this sample, all time periods are based on July 25, 2013.

24 Hours	7 Days	30 Days	Last 12 Months
From July 24 12:00AM until July 25 12:00AM	From July 18 12:00AM until July 25 12:00AM	From June 25 12:00AM until July 25 12:00AM	From July 25, 2012 12:00AM until July 25, 2013 12:00AM

The values in the table below are calculated as follows:

Reporting Period	Start Date and Time	End Date and Time	PUE	Average Load	
				Data Center	IT Equipment
24 Hours	7/24/2014 12:00:00 AM	7/25/2014 12:00:00 AM	1.99	70 kW	35 kW
7 Days	7/18/2014 12:00:00 AM	7/25/2014 12:00:00 AM	1.98	70 kW	36 kW
30 Days	6/25/2014 12:00:00 AM	7/25/2014 12:00:00 AM	1.94	72 kW	37 kW
12 Months	7/25/2013 12:00:00 AM	7/25/2014 12:00:00 AM	1.83	57 kW	31 kW

**PUE** – The ratio between the data center and IT equipment energy measurement values. This value is calculated for each of the required time periods by the following formula:

$$PUE = \frac{\text{Sum of Data Center Energy}}{\text{Sum of IT Equipment Energy}}$$

**IT Equipment** – The average of the IT equipment power measurement values for each of the time periods.

**Data Center** – The average of the data center power measurement values for each of the time periods.

The values displayed in the charts below are calculated as follows:

PUE Trend - Last 12 Months with Weekly Rollup Values

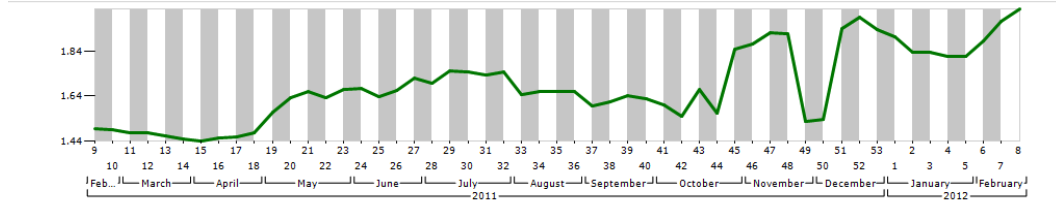

Energy Trend - Last 12 Months with Weekly Rollup Values

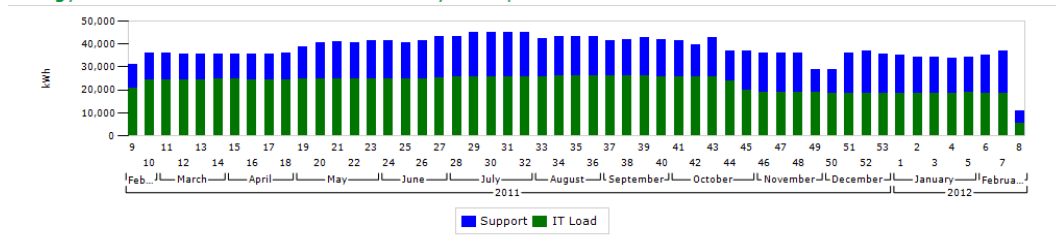

**PUE Trend** – The weekly PUE values are calculated by the following formula where N represents a week of the year:

<b>PUE</b> week N =	Sum [ Data Center Energy ] week N
	Sum [ IT Equipment Energy ] week N

**Energy Trend** – The weekly energy values for IT equipment and support are calculated by the following formulas where N represents a week of the year:

**IT Equipment Energy** week N = Sum [ IT Equipment Energy ] week N

**Support Energy** week N = Sum [ Data Center Energy ] week N - Sum [ IT Equipment Energy ] week N

# UPS Performance

## Uninterrupted Power Supply (UPS) Auto Test

The Uninterrupted Power Supply (UPS) Auto Test solution provides a Vista diagram to the user in order to monitor the MGE5500 series UPS in Power Monitoring Expert.

---

**NOTE:** The UPS Auto Test solution is supported only for the MGE5500 UPS.

---

## Adding UPSs to Management Console

1. Log in to the Management Console.
2. In Management Console, click **Devices** and add each new UPS device.

## Configuring UPS Groups with UPS Configuration Tool

1. Open the UPS Configuration Tool.
2. In the UPS Configuration Tool, click **New** and add each new UPS that you added in the Management Console.
3. (Optional) Change the value for the **Display Name** that appears in the Vista diagram if you want.

This **Display Name** appears only in the Vista diagram and does not impact the name that you use in the Management Console.

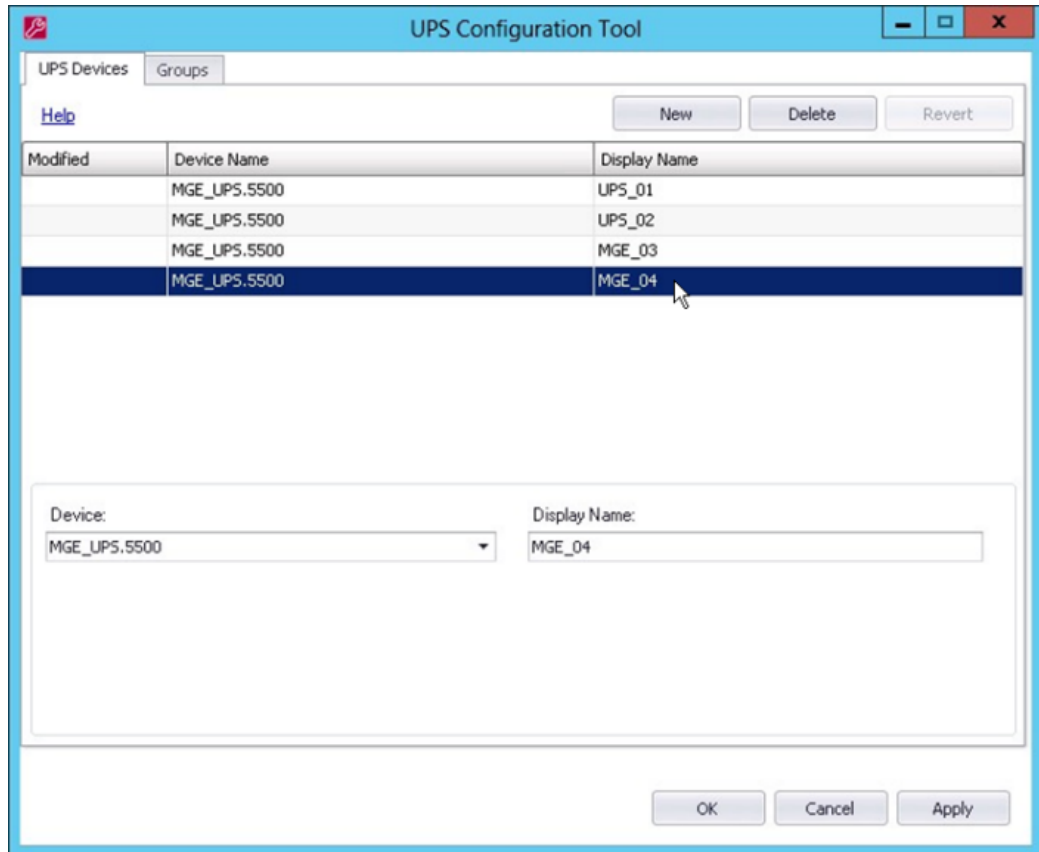

- 4. After adding all new UPS devices, click the **Groups** tab.
- 5. Click **New** to create new groups for the UPS devices.

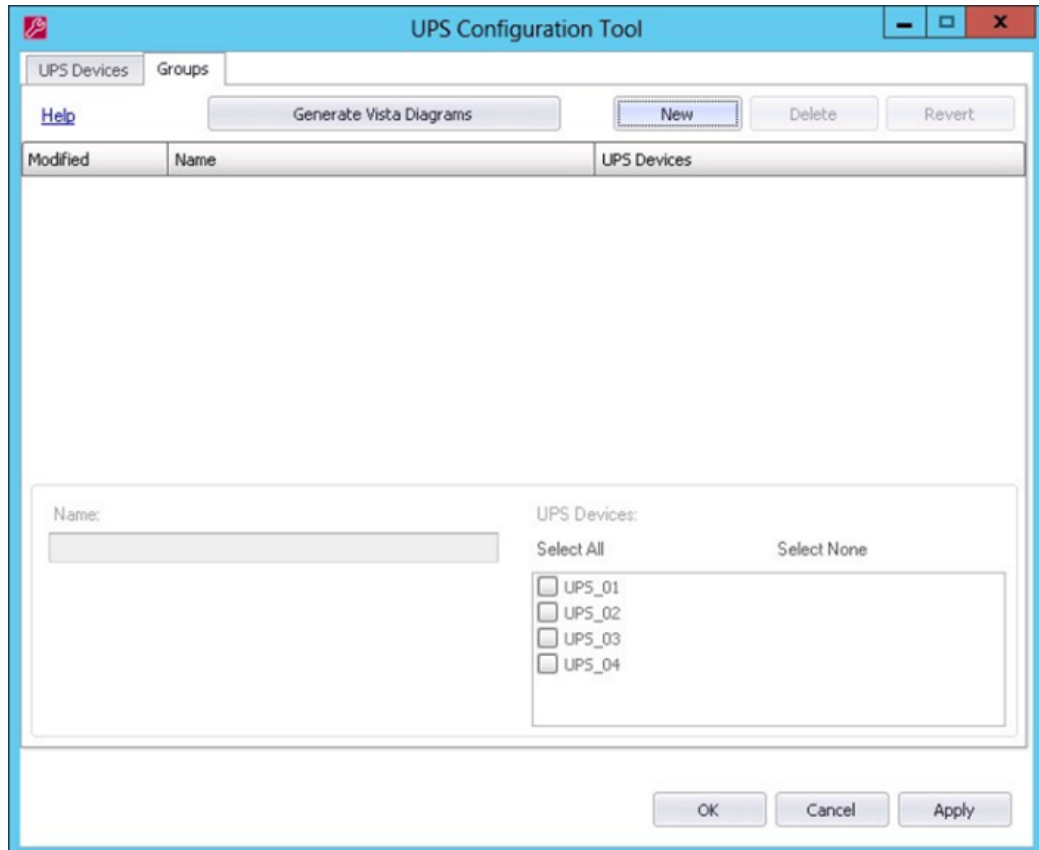

6. After you finish adding all UPSs and associated groups, click **Apply**.

## Generating a Vista diagram

1. Click **Generate Vista Diagrams**.

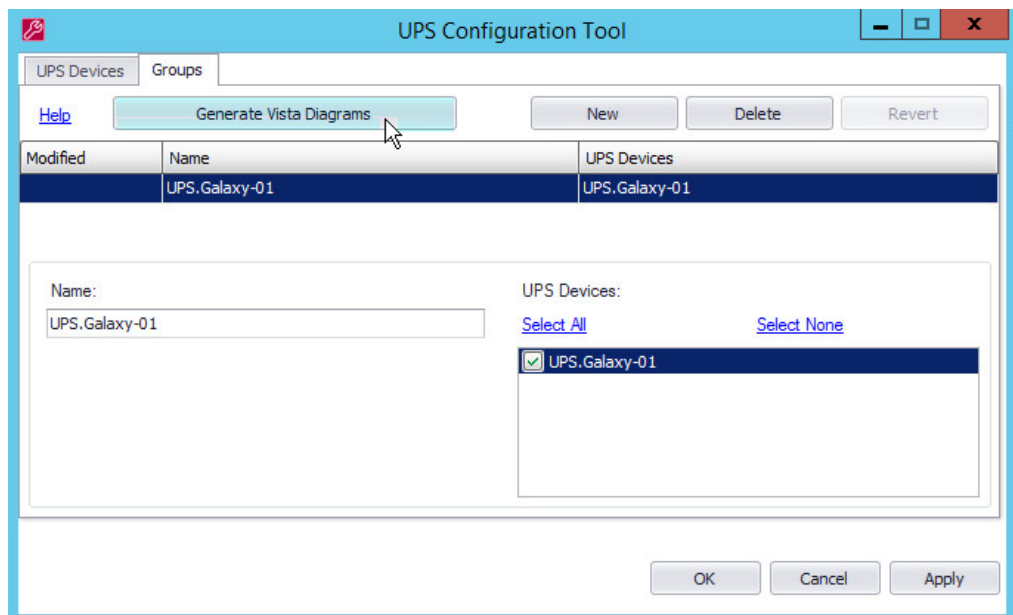

The **Vista Diagram Generation** dialog appears.

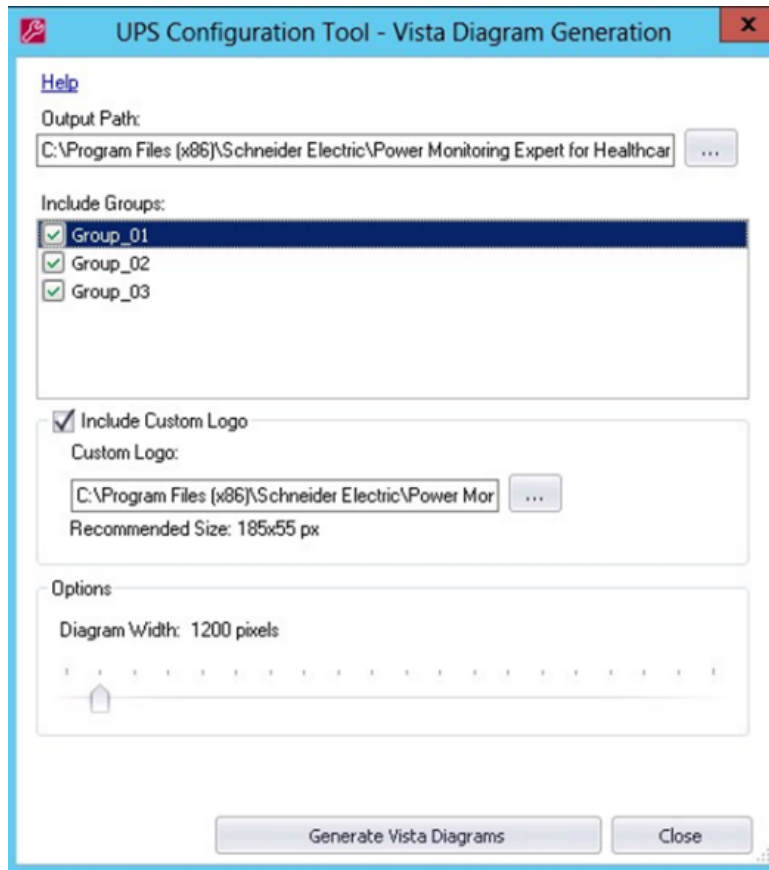

The **Output Path** shows where the Vista diagram .dgm file is saved after clicking **Generate Vista Diagrams**. The file name or location can be modified from the default value if desired.

2. Select the check box for **Include Custom Logo** and then navigate to and select the file in order to include a custom logo in your diagrams. Otherwise, a Schneider logo appears.
3. Under **Options**, drag the indicator to define the width and dimensions of Vista diagrams you generate.
4. Click **Generate Vista Diagrams** to generate the .dgm files, then click **Close**.

## Pasting UPS framework in VIP

1. Open the Designer tool and open the VIP.<servername>.node.
2. Drag a Grouping Object and open it. Make sure that the toolbox is available (**Options > Show toolbox**).
3. Go to `...\config\fmwk\UPS\` and select **Edit > Paste** to paste the framework. Depending on the number of UPSs and groups, you may need to set up the framework. The default template assumes the user has two groups with five UPSs in each group.

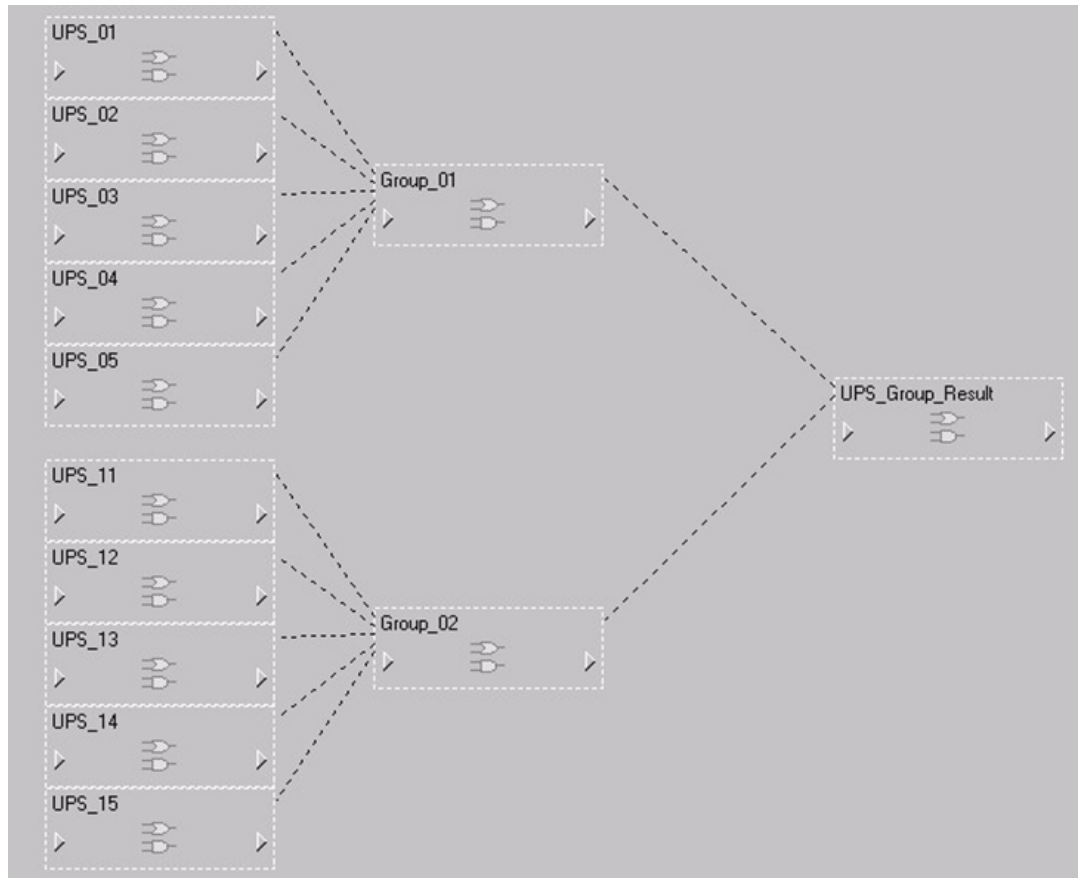

The example below shows an instance where the user has three groups with a different UPS in each group:

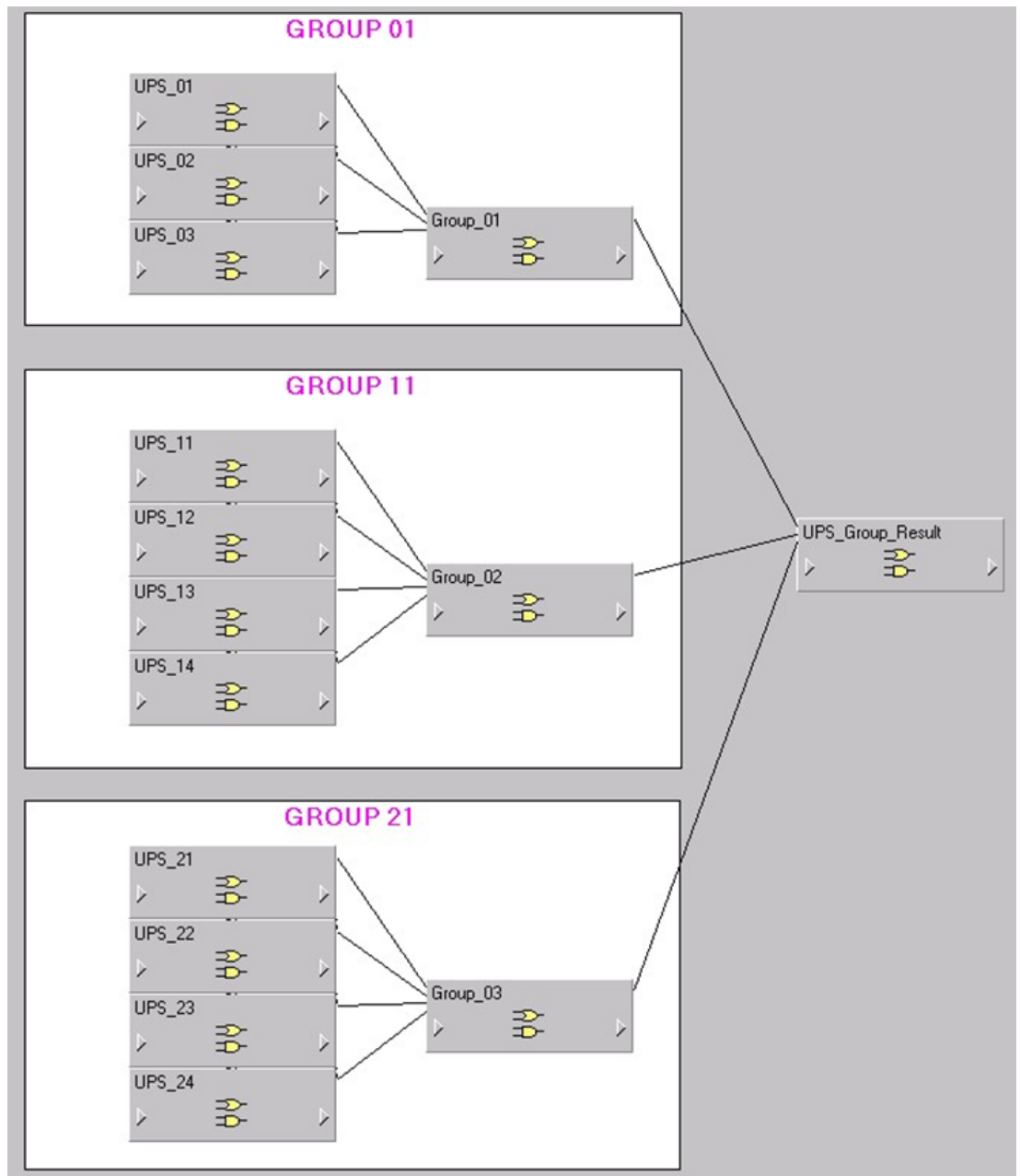

4. Connect the inputs of each AND/OR module (UPS) to the critical operation and battery usage status.

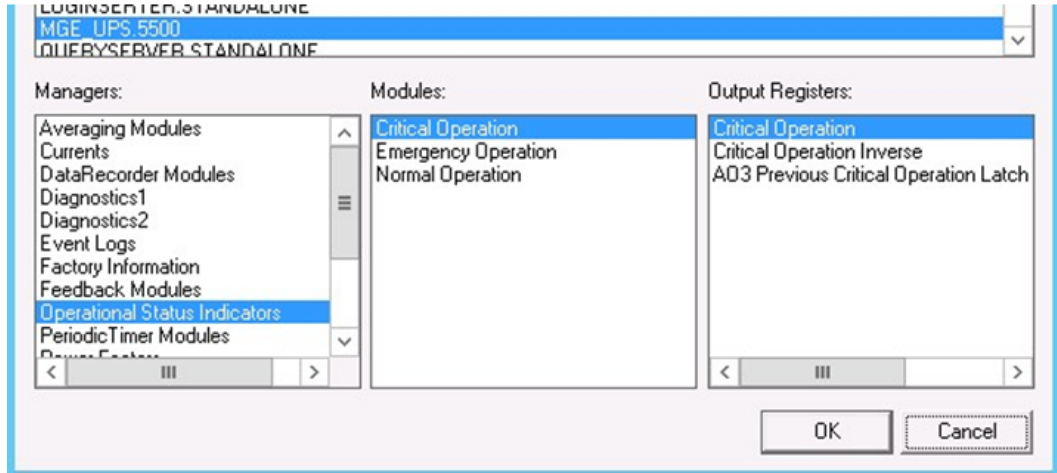

5. Repeat this step for each UPS in the group and for all of the UPSs in the other groups.
6. Save the framework after you finish modifying the framework based on your UPS system.

## Setting up Vista Diagram status

1. Browse to `... \config\diagrams\ud\UPS\UpsGroups.dgm`.

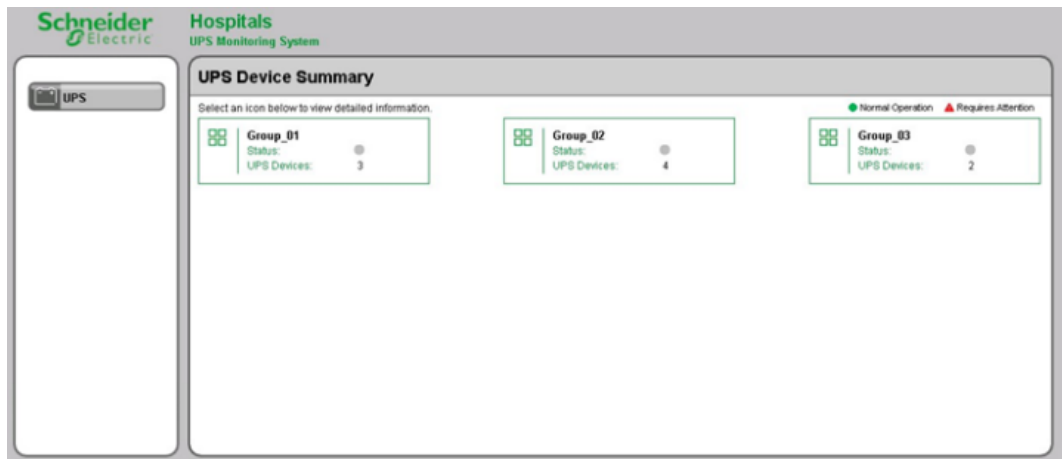

2. Link the status object from the framework that you pasted in VIP in the previous steps.

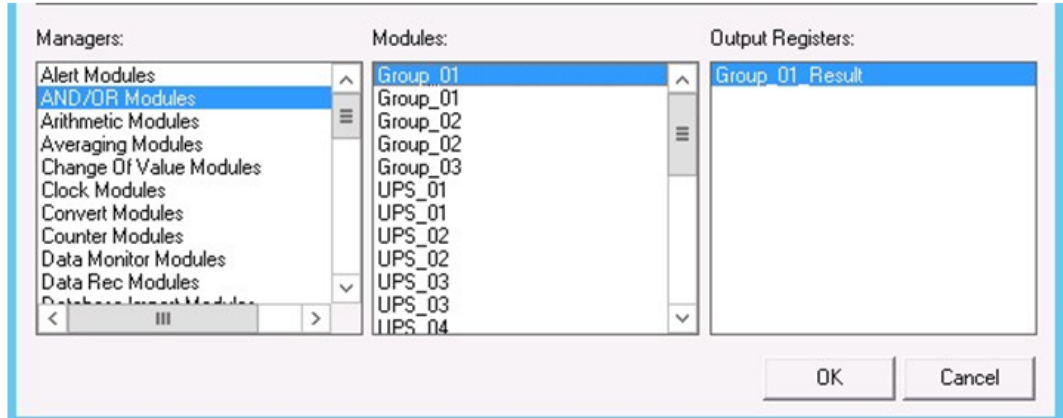

- Repeat this step for all other groups. Your UPS Monitoring system is now setup. Any UPS in the groups that require attention show a red indicator.

## Running a report

After you finish configuring all UPSs, you can run a report by selecting a group.

## Uninterrupted Power Supply (UPS) Auto Test Report

The **UPS Auto Test Report** shows the test solution and provides a Vista diagram to the user in order to monitor the MGE5500 series UPS.

For more information on generating and managing reports, see the "Reports" section of the Web Applications help file.



# Uninterrupted Power Supply (UPS) Battery Health Report

The **UPS Battery Health Report** is designed to show information related to the health of the battery for a UPS device. The UPS devices intended for use with this report are UPS devices that do not have an auto-test capability.

## Supported Devices

The only devices supported by UPS Battery Health are as follows:

- ION7550 / ION7650

The UPS Battery Health system contains several components that provide the customer with information about the generator battery bank. Specifically, the monitor shows the customer the starting voltage signature when the UPS comes online, which indicates the battery bank's voltage drop and recovery at that time.

The following tasks must be completed to set up the UPS Battery Health system:

- Install and configure the ION 7550 / ION7650 meter to the battery bank to be monitored. Refer to the *PowerLogic ION7550 / ION7650 Installation Guide* and *PowerLogic ION7550 / ION7650 User Guide* for more information. Obtain the latest version of these documents from [www.schneider-electric.com](http://www.schneider-electric.com).

Note the following:

- V1 - V3 voltage inputs must have PTs in order to isolate the ground from the system being monitored and the battery.
- Connect V4 to the positive side of the battery. Input impedance of V4 terminal is 5 Mohm (phase - Vref). For the most up to date specification, contact the local representative.
- Connect Vref to battery ground.
- Fusing must be installed according to the meter installation instructions.
- Perform visual inspection of connections to ensure there is physical separation between the system connected to V1, V2 and V3, and the battery connected to V4.
- For other wiring options with PTs, see the *PowerLogic ION7650 Installation Guide*.

## DANGER

### EQUIPMENT ELECTRIC SHOCK, EXPLOSION, OR ARC FLASH

Treat the battery circuit as energized to the category of the installation.

**Failure to follow these instructions will result in death or serious injury.**

Refer to the following diagram as an example for connections to the meter.

#### 4-Wire Wye, 3-Element, 3 PTs Connection Diagram

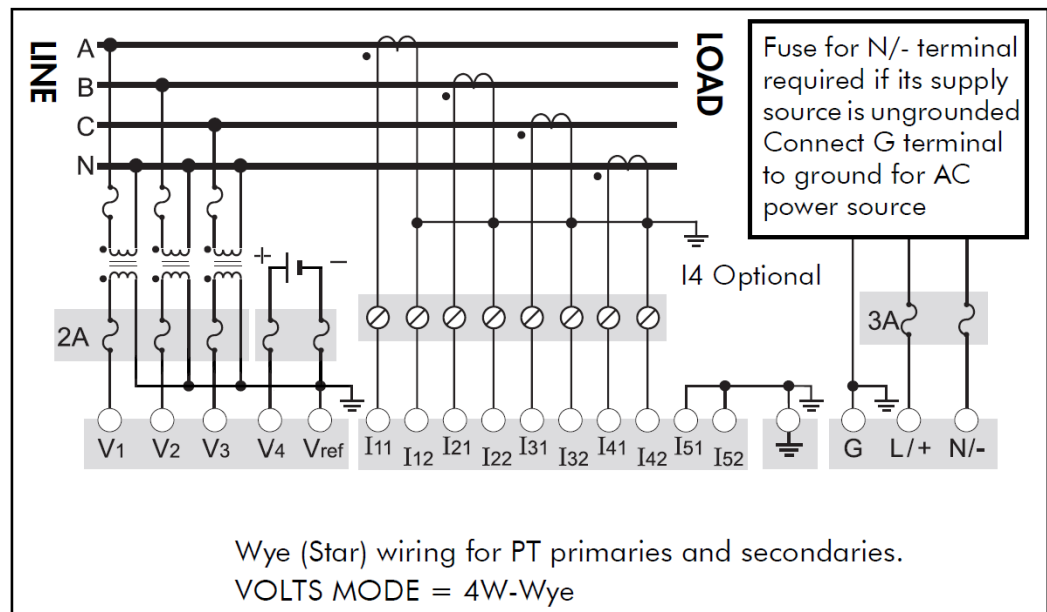

- Configure the UPS Battery Health Framework to capture the battery voltage signature or waveform and deploy the framework to the meter. See the next section for instructions.
- Configure the UPS Battery Health Report to display the graph of the voltage signature. The customer can use the report to help understand the battery bank condition.

This chapter provides instructions for configuring the framework to capture the voltage signature.

## Configuring the UPS Battery Health Framework

The UPS Battery Health Framework is designed to capture and record a UPS's battery voltage signature at start up. This voltage signature provides some indication of the health of the UPS's battery bank. A typical waveform capture of the voltage drop when the UPS comes online is shown below:

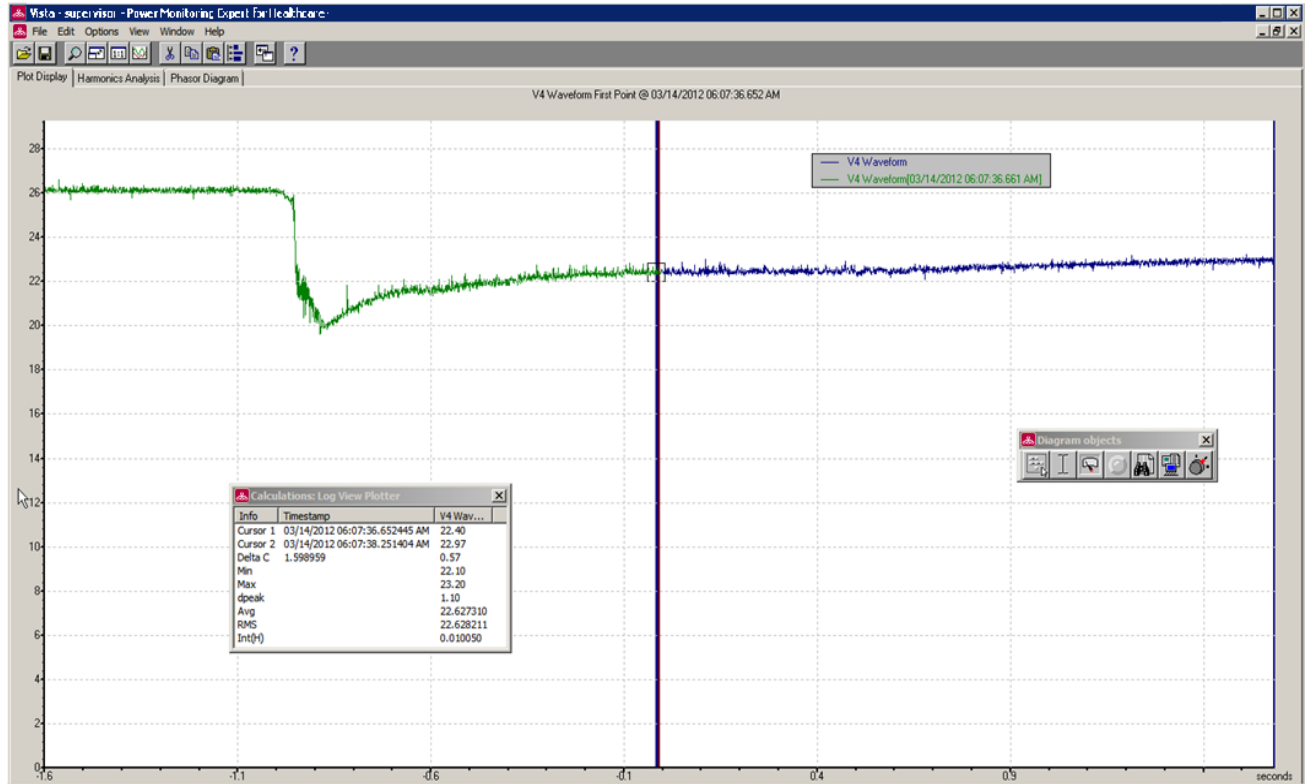

Note the following items about this example:

- This capture shows about 4 - 5 seconds worth of data, accomplished via one (1) waveform recorder configured at a resolution of 512 x 4.
- The voltage does not immediately recover to its original value but it begins to ramp up.
- There is about 0.5 seconds of data before the voltage drop to approximately 20 V.

Two options in the framework are possible to capture the waveform, based on how the crank relay signal is triggered - pulse or KYZ.

## Example Framework

The types of module used are:

- Data Acquisition
- Digital Input
- Convert
- OneShot Timer
- Waveform Recorder

See the following descriptions for the way each module works in this framework.

Refer to *ION Reference* for details on how each module operates and for setting module parameters.

## Data Acquisition – Data Acqn 1

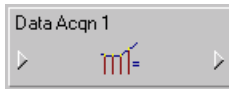

The V4 signal from the meter goes to the Data Acquisition module.

## One-Shot Timer

To prevent triggering the downstream logic twice, send the state from the Convert module into the One Shot Timer:

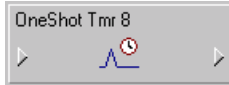

Send the output register into the first Waveform Recorder G1 Battery 1.

## First Waveform Recorder – G1 Battery 1

The Data Acquisition module is the input to the first Waveform Recorder, labeled “G1 Battery 1.”



These are the setup registers for the module:

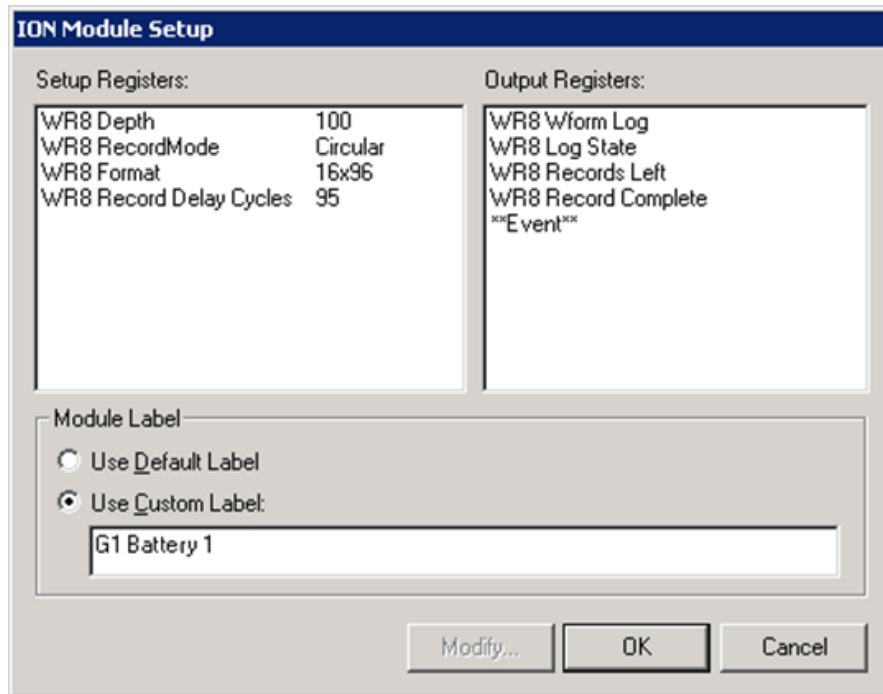

Note the following about the setup registers:

- Depth must be non-zero – 100 hundred is a good number.

- Record Mode should be Circular.
- Format should 16x96. This means 16 samples per cycle and 96 cycles, so at 60 Hz this results in approximately 1.6 seconds worth of data.
- Record Delay Cycles is set to 95 to allow the “window of observation” to move so that only post-event data is captured. Refer to *ION Reference* for more details.

## Configure and Generate the UPS Battery Health Report

Use the Reports module in Web Applications to configure and produce the UPS Battery Health Report.

For more information on generating and managing reports, see the "Reports" section of the Web Applications help file.

## UPS Battery Health Report Example

In this example, the starting voltage waveform (blue) is similar to the reference waveform (red). The drop to near 51 volts DC is the point at which the generator started. After the start, battery voltage rises to normal state of charge.

The first section shows a summary table of the reference and comparison waveforms. It shows the timestamp for the waveform that corresponds to the recorder timestamp of the waveform, and whether or not the drop or recovery are found.

The next section shows a chart that shows the reference and comparison waveforms in a stacked view. If a voltage drop is found in both waveforms, then those waveforms are *time aligned* based on their **voltage drop minimum** values. If a drop is *not* found in both waveforms, then those waveforms are *time aligned* based on their **absolute minimum** values.

The chart shows a gray band around the Analysis Section that represents the section of the waveform where the voltage drop and recovery voltage samples are found.



## Ups Battery Health Report

### Battery Waveform Health Evaluation for Ups: at 6/6/2014 3:28:40 PM.

	Timestamp	Drop Found?	Recovery Found?
Reference Waveform	5/12/2014 10:27:19 AM	Yes	Yes
Comparison Waveform	6/6/2014 3:28:40 PM	Yes	Yes

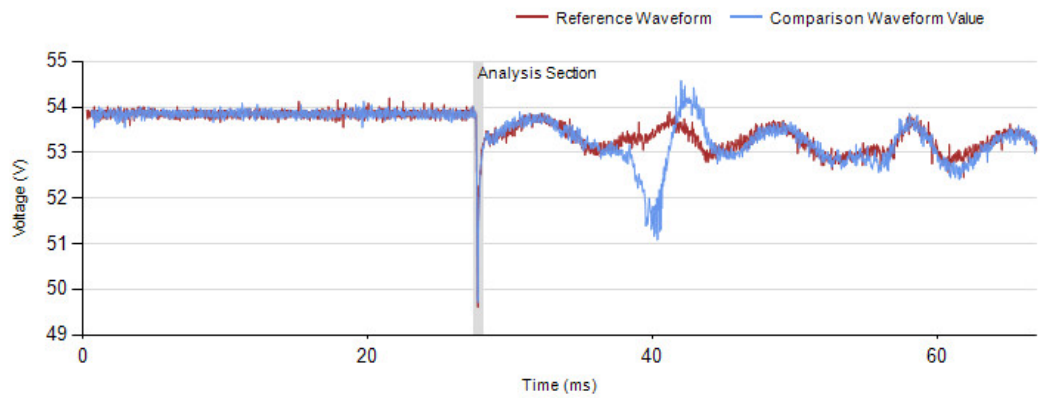

This section shows a chart with details of the waveform analysis. Following the analysis table, a chart shows a stacked view of the reference and comparison waveform voltage drops. The chart also shows a red horizontal band that represents the area that is under the voltage threshold.

	First Voltage Drop Analysis			Voltage Recovery Analysis		
	Minimum Drop Voltage (V)	Maximum Drop Voltage (V)	Difference (%)	Target Recovery Voltage (V)	Actual Recovery Voltage (V)	Recovery Time (ms)
Reference Waveform	49.60	53.93	8.02%	53.30	53.32	0.49
Comparison Waveform	49.72	53.89	7.75%	53.30	53.32	0.52

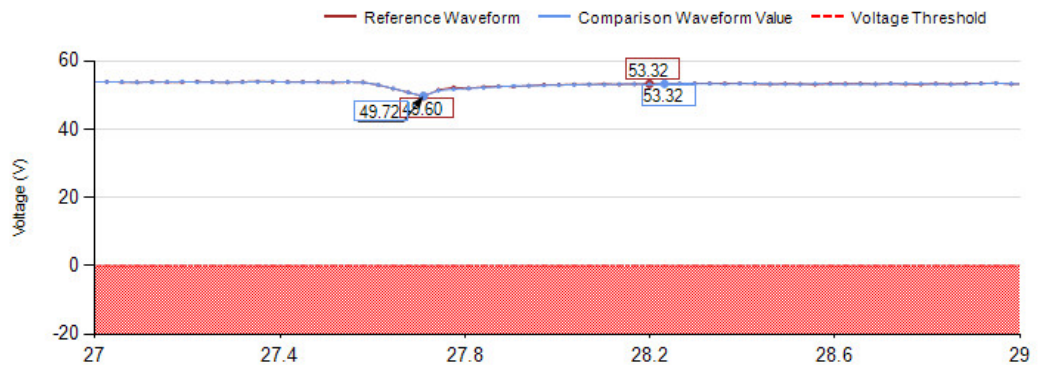

# Telvent Weather Data Import Service

The Telvent Weather Data Import Service allows you to import current weather data from the Telvent weather source you specify into Power Monitoring Expert in order to forecast weather conditions and to correlate weather-related conditions to energy consumption. The Telvent Weather Data Import Service device driver can import real-time and historical data into Power Monitoring Expert.

---

**NOTE:** The Telvent Weather Data Import Service requires an active Telvent subscription account.

---

## Configure the data import service

To begin using the Telvent Weather Data Import Service, you must first configure it using the Modbus Service Configuration Tool and the Management Console.

## Run the Modbus Service Configuration Tool

1. In **Windows > Explorer**, navigate to the **system\bin** folder and then double-click **ModbusServiceConfigurationTool.exe** to run it. The **Modbus Service Configuration Tool** dialog appears.
2. Click **Add**. The **Add Service Window** dialog appears.

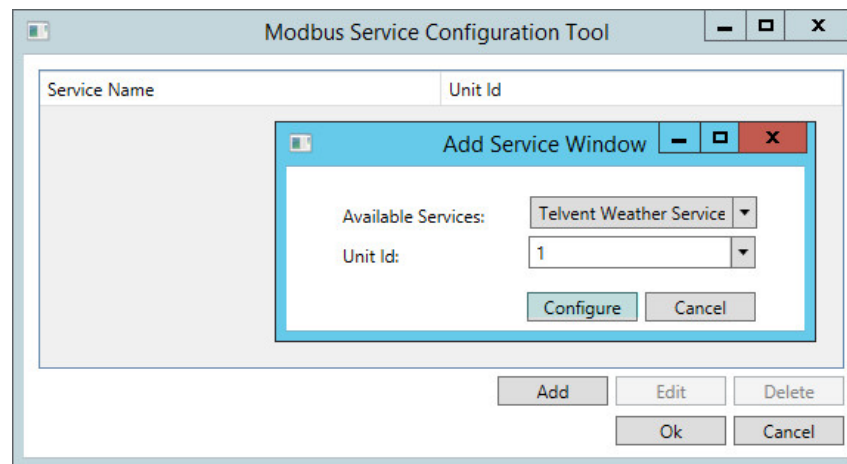

3. From the **Available Services** dropdown list, select **Telvent Weather Service**.
4. For **Unit ID**, enter "1" and then click **Configure**. The **Telvent Weather Service Configuration** dialog appears.

5. Complete the fields as follows:

**Telvent User Name** field: Enter your Telvent subscription user name.

**Telvent Password** field: Enter your Telvent subscription password.

For location, choose and complete the fields for one of the following:

**GPS Location:** Enter values for **Latitude** and **Longitude**.

**Station ID:** Enter a specific Weather Station ID.

**Postal Address:** Enter a postal address (ZIP or postal code).

From the dropdown lists, select the unit measurements you want. For **Degree Day**, enter what the Telvent weather service provides as units.

6. Click **OK**. **Telvent Weather Service** now appears in the list under **Service Name** in the Modbus Service Configuration Tool dialog and begins collecting data immediately.

Service Name	Unit Id
Telvent Weather Service	1

7. Click **OK**, and then click **Yes** to restart the Modbus Software Gateway Service.

## Configure the Management Console

1. From the desktop, navigate to the ...\**Power Monitoring Expert 8.1 Healthcare Edition** folder and double-click **Management Console**, enter your user name and password, and click **OK**. The **Management Console** dialog appears.
2. In the left pane, click **Sites**.
3. Right-click on the dialog and choose **New > Ethernet Gateway Site**.

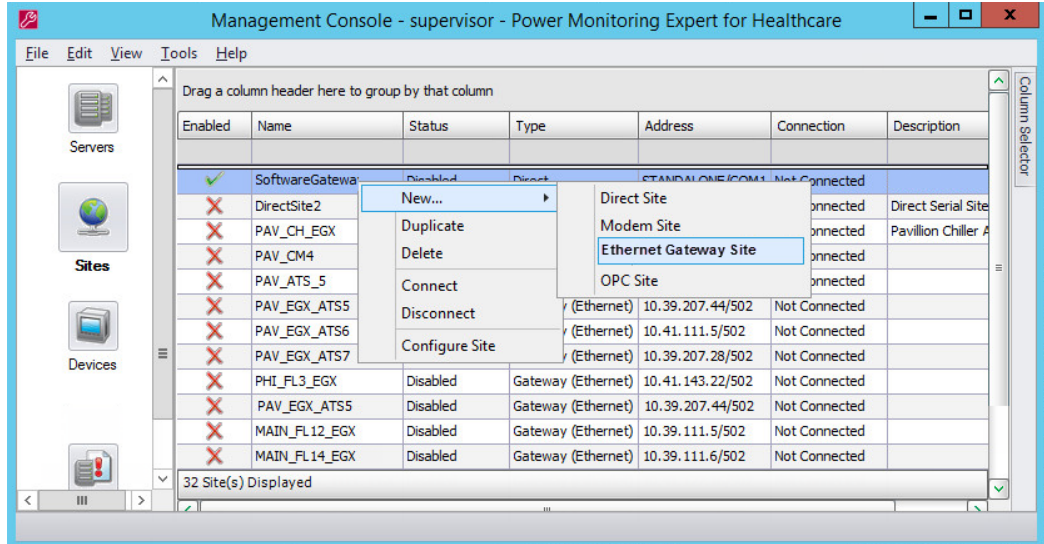

The **Ethernet Gateway Site Configuration** dialog appears.

Field	Value
Name	SoftwareGatewayService
TCP/IP Address	10.12.44.101
TCP/IP Port	502
Computer	STANDALONE
Time Synch ION Enabled	No
Time Synch 3XXX Enabled	No
Time Synch 3720 Enabled	No
Enabled	Yes
Description	

TCP/IP Port  
Select the TCP/IP port to use for this site.

OK Cancel

- Complete the fields as follows:
  - Name** field: Enter a name for the site, such as SoftwareGatewayService.
  - TCP/IP Address** field: Enter the local IP address or the server name where Power Monitoring Expert 8.1 Healthcare Edition is installed.
  - TCP/IP Port** field: Enter port **502**.
- Click **OK**.
- In the left pane, click **Devices**.
- Right-click on the dialog and choose **New > Serial Device on Ethernet Gateway Site**.

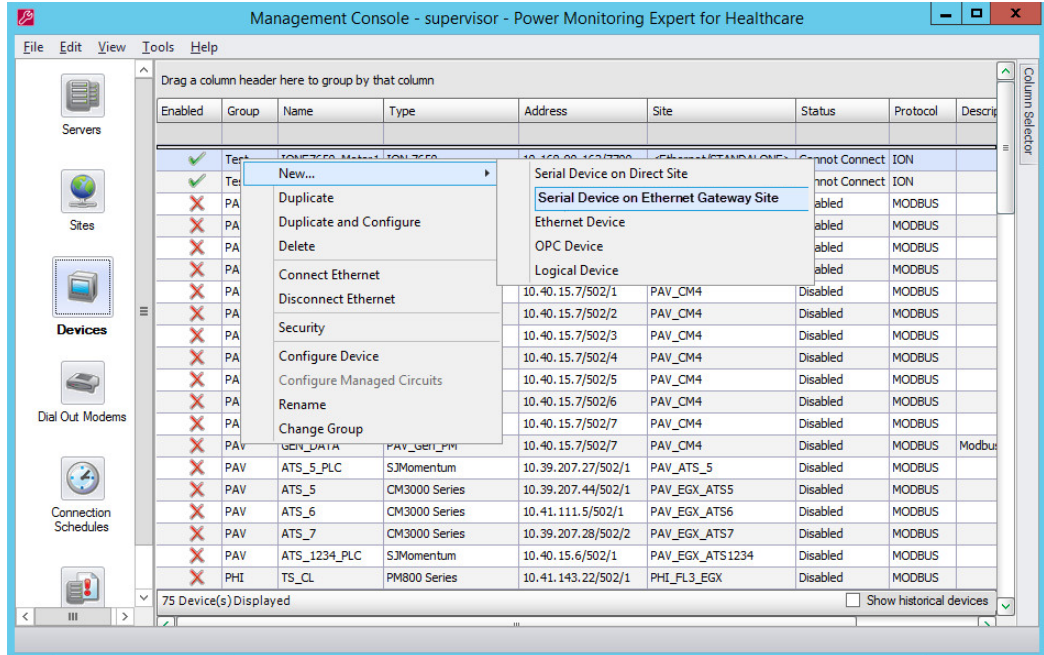

The **Serial Device Configuration** dialog appears.

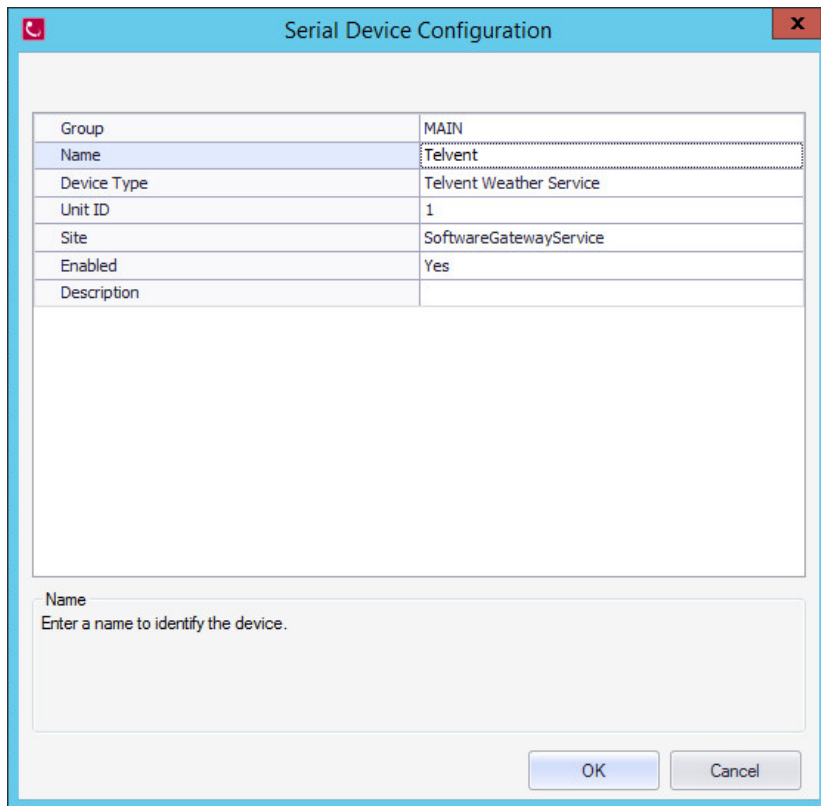

8. Complete the fields as follows:

**Group** field: Select a group for the device, such as MAIN.

**Name** field: Enter a name for the device, such as Telvent.

**Device Type** field: Select Telvent Weather Service.

**Unit ID** field: Enter "1" .

**Site** field: Select **Software Gateway Service**.

**Enabled** field: Choose **Yes**.

**Description** field: Enter a description of the device if you want.

9. Click **OK**. The new device now appears in the list of devices. The Telvent Weather Data Import Service is now configured.

## Verifying the service is active

After the Telvent Weather Data Import Service is configured, you can verify that the service is active in Vista.

1. Select the site you configured, such as **SoftwareGatewayService**.
2. From the desktop, navigate to the ...\**Power Monitoring Expert 8.1 Healthcare Edition** folder and double-click **Vista**.
3. Log in with your username and password, and then click **OK**. The **Vista** dialog appears.
4. Choose **File > New** to create a new diagram.
5. Drag a Numeric Object from the toolbar onto the diagram.
6. Right-click on the object and then click the **Link** tab.
7. Select **Custom** and click **Edit Link**.
8. In the **Create Link** dialog, select the device you configured, such **Weather.Telvent**, and click **OK**.
9. Make selections for **Managers**, **Modules**, and **Output Registers**, and then click **OK**.
10. Open the Vista diagram and verify that the service is logging observed measurements.

**NOTE:** All observed measurements are logged and all observed measurements are read in real time. Hourly observed measurements are logged every half-hour, and all daily observed measurements are logged every 12 hours.

# AccuSine<sup>®</sup> Power Correction System (PCS) device

The AccuSine Power Correction System device is used to help reduce maintenance and wear on an electrical system and to improve Power Quality. Adding a AccuSine Power Correction System device to your Power Monitoring Expert system allows you monitor and correct the harmonics of the power for your buildings.

## Configuring the AccuSine PCS device

To begin using the AccuSine Power Correction System, you must first configure it using the Management Console.

1. Navigate to and double-click **Management Console**. The **Management Console** dialog appears.
2. In the left pane, click **Devices**.
3. Right-click on the dialog and choose **New > Ethernet Device**.

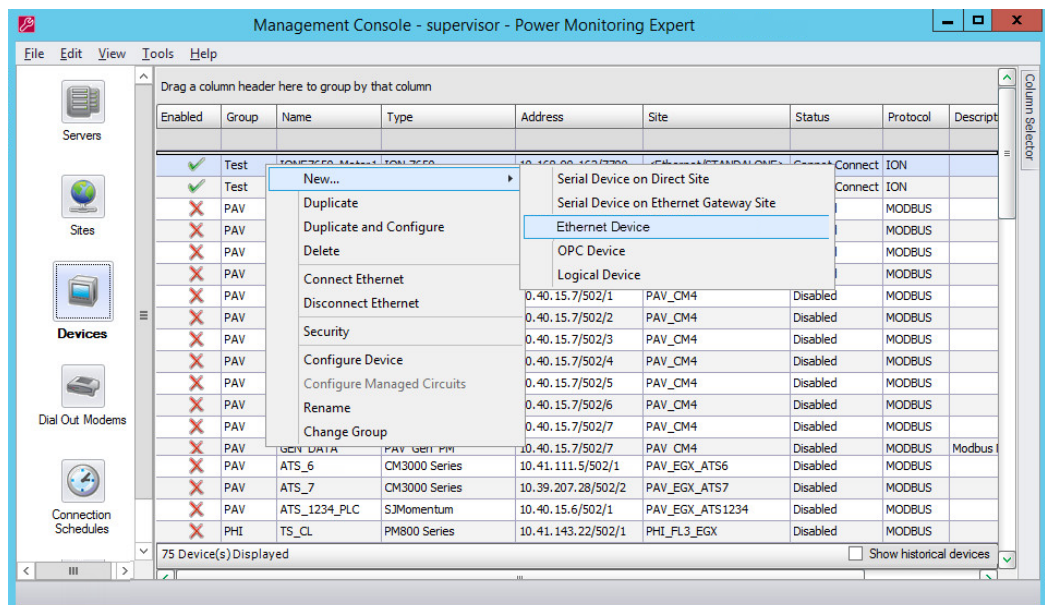

The **Ethernet Device Configuration** dialog appears.

Group	Correction
Name	AccuSine
Device Type	AccuSine_PCS
TCP/IP Address	10.168.88.77
Computer	STANDALONE
Enabled	Yes
Description	

Description  
Enter a description for the device.

OK Cancel

- Complete the fields as follows:
  - Group** field: Select a group for the device, such as Correction.
  - Name** field: Enter a name for the device, such as AccuSine.
  - Device Type** field: Select **AccuSine\_PCS**.
  - TCP/IP Address** field: Enter your server IP Address.
  - Computer** field: Enter the name of your server.
  - Enabled** field: Select **Yes**.
  - Description** field: Enter a description of the device if you want.
- Click **OK**. The new device now appears in the list of devices. The AccuSine Power Correction System is now configured.

## Verifying the device is active

After the AccuSine Power Correction System is configured, verify that the device is active.

- In **Vista**, generate the network diagram.
- Open the network diagram.
- Click on each tab to verify that harmonic measurement data appears in each.

**NOTE:** Allow a few moments for measurement data to appear and refresh on the tabs.

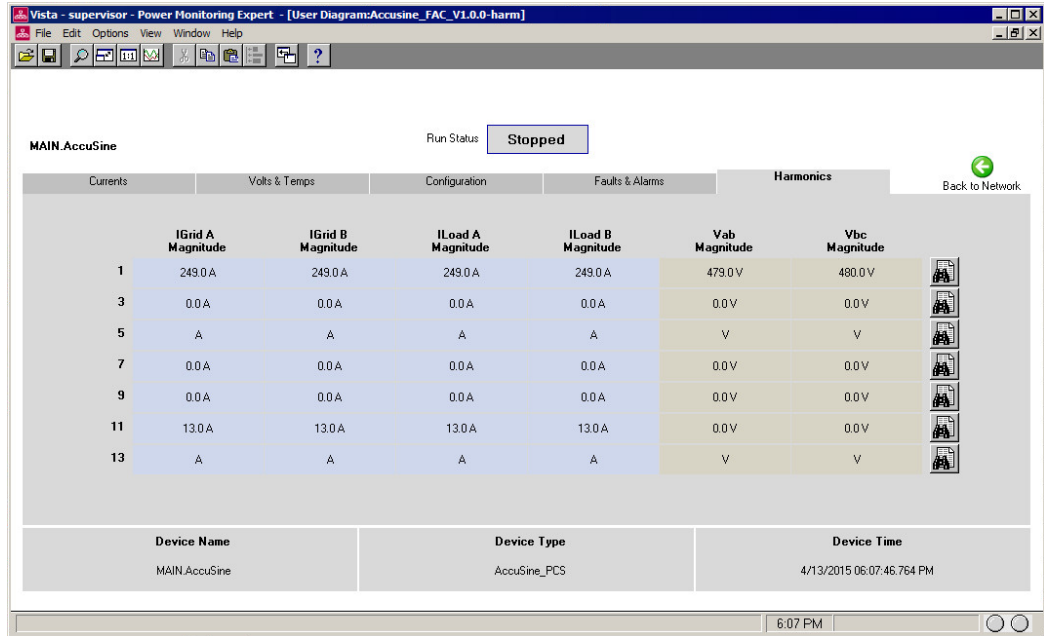

4. After you verify that the monitoring and correction is active, close the diagram.

# Reference

# ION Power Meter Configuration

This section describes how to complete the following tasks:

1. Add ION power meters to the Power Monitoring Expert solution.
2. Deploy a custom framework on an ION power meter using the Designer application of Power Monitoring Expert solution.
3. Configure the framework with site-specific information.

Experience using ION Setup, Designer, and other software is necessary to configure ION power meters. Successful completion of these tasks ensures that:

- The operational states on the Active Transfer Switches (ATS) and generators are associated with the digital inputs on the ION power meters, and that the digital inputs are appropriately labeled and logged in the ION\_Data database.  
ATS do not need to be configured for the Generator Performance module, only for EPSS.
- The engine data for the generators is associated with the analog inputs on the ION power meters, and that the analog inputs are appropriately labeled and logged in the ION\_Data database.
- The electrical details for the generators are logged and saved in the ION\_Data database.

## WARNING

### UNINTENDED OPERATION

- Do not use ION meters for critical control or protection applications where human or equipment safety relies on the operation of the control circuit.
- Refer to the *ION Reference* for more information on ION module operation.

**Failure to follow these instructions can result in death, serious injury, or equipment damage.**

## Supported ION Power Meters

Power Monitoring Expert can use the following ION power meters:

- PM8000, ION7550 and ION7650 for ATSs only, generators only, or for generators and ATSs combined
- ION7550 RTU for ATSs only

### Related information

For information about adding ION power meters to Power Monitoring Expert, see the Management Console online help or the *StruxureWarePower Monitoring Expert Help*.

For details about configuring Analog or Digital Input modules, refer to *ION Reference*.

## Maintenance and Backups

As a good practice, always save a backup of the final framework that is pasted onto the meter. Use Designer to create a copy of the framework from the meter. Save the framework to a location from where the framework can be pasted back to the meter if necessary.

Be sure to save a backup of the meter's framework before deploying and configuring the EPSS frameworks.

If a meter needs to be replaced, use the backup copy of the ION meter framework for the new ION meter. For all other installation and configuration steps, you must follow the original commissioning steps as described in the following sections.

Refer to existing Power Monitoring Expert documentation for instructions to backup meter frameworks.

## Prerequisites

The following items must be completed before attempting to configure ION power meters to record data from generators, automatic transfer switches (ATS) and other equipment.

- Power Monitoring Expert must be installed and operational.
- All ION power meters must be installed and communicating.
- ION power meters selected to monitor **each ATS device** must have the following available data recorders and inputs:
  - One available data recorder
  - At least three available digital inputs (site specific)
- ION power meters selected to monitor **each generator device** must have the following available data recorders and inputs:
  - Two available data recorders
  - Three available digital inputs (site specific)
  - Two available data recorders
- See ["Additional Information about Digital and Analog Inputs" on page 181](#) for more information.
- Each ATS should be physically wired to the appropriate ION power meters so that the following status signals are represented:
  - Normal
  - Emergency
  - Test
  - Power Outage (optional)
- Each generator should be physically wired to the appropriate ION power meters so that the following status signals are represented:

- Start (optional)
  - Emergency Power Source Available (optional)
  - Run
  - Stop
- The following generator electrical data must be metered and available for each generator:
    - VIn a
    - VIn b
    - VIn c
    - VIn avg
    - VII ab
    - VII bc
    - VII ca
    - VII avg
    - I a
    - I b
    - I c
    - I avg
    - kW tot
    - kVA tot
    - PF sign tot
    - Freq

## Additional Information about Digital and Analog Inputs

### Digital Inputs

Meters used to monitor generators and other equipment must have enough available digital inputs to handle the incoming status signals. The number of required digital inputs depends on how many signals are available and whether they are single state or dual state signals.

Example of single state signals, where signalA represents GEN Running

- When signalA = 1, GEN Running is TRUE
- When signalA = 0, GEN Running is FALSE

Example of dual state signals, where signalA represents GEN Running and GEN Stopped

- When signalA = 1, GEN Running is TRUE
- When signalA = 0, GEN Stopped is TRUE

### Analog Inputs

Meters used to monitor generators must have available analog inputs to handle the incoming generator-specific analog data. The number of required analog inputs depends on how many measurements are being recorded. For example, analog data can include the following:

- Exhaust Gas Temperature left and right
- Engine Coolant Temperature in and out.
- Engine Oil Pressure

Generator analog signals can be obtained through the analog inputs or via Modbus Master from the engine controller. Refer to the *PowerLogic ION7550/7650 User Guide* for more information.

## Add ION Devices to the System

Follow these steps to add ION power meters to your system configuration.

Complete these steps to prevent any unwanted database actions when modifying the meter framework.

1. Stop the Log Inserter Service, as follows:
  - a. Open the Windows Services panel by clicking:

**Start > Administrative Tools > Services**

The path to **Services** may vary depending on the Windows operating system being used.

- b. Right-click **ION Log Inserter Service** and select **Stop**.
2. Open the Management Console.
3. Use the Device window in Management Console to add each ION power meter.

The Device window includes **Group** and **Name** fields. **Group** is the name under which you want to associate the device you are adding. **Name** identifies the meter that you are adding. The meter name should include a reference to identify which ATS or generator is connected to the meter.

When a meter has been added it appears in the list of devices in *group.name* format. For example, if you named the group **EPSS**, and identified the meter as **ATS1**, the name in the device list is **EPSS.ATS1**. Similarly, if you used the same group to add a meter identified as **GEN1**, the name in the device list is **EPSS.GEN1**. See the *StruxureWare Power Monitoring Expert User Guide* or online help for information about adding a meter.

After the power meter is added, configure the appropriate frameworks as described in ["Deploying ATS Frameworks for EPSS" on page 182](#) and ["Deploying Generator Frameworks" on page 192](#).

## Deploying ATS Frameworks for EPSS

### Overview

Use Designer to copy and paste the ATS framework to your ION power meter. Repeat this process for every power meter in your system that records ATS data for EPSS purposes.

### Pasting ATS Frameworks

Before you deploy ATS frameworks, you need to be aware of the implications of free pasting and lock pasting modules.

Use free pasting to paste a new module with a different name if a module with the same name already exists. This helps to ensure that existing modules and their functionality are not replaced.

Use lock pasting to overwrite an existing module and its functionality with a new module, while retaining the module name. However, you need to understand what the modules are currently being used for before you lock paste the modules. A lock paste replaces the functionality of those modules.

- If a power meter already uses all modules of a certain type that are a necessary part of the framework, then a lock paste operation is required.

- If all of the available digital or analog input modules are in use, a lock paste of the analog or digital input modules is required to help ensure that the parameter settings are updated

## Copy the ATS Framework to the ION Power Meter

Use Designer to copy and paste the ATS framework to the power meter. Repeat this process for every power meter in the system that records ATS data for the EPSS.

Follow these steps to copy the ATS framework and paste it to the power meter.

1. In **Management Console** click **Tools > System > Designer**. The Designer login window appears.
2. Enter the login credentials with administrator or supervisor access and click **OK**.
3. Click **File > Open**, select the power meter that has the ATS connected to it, and then click **OK** to open the meter's framework.

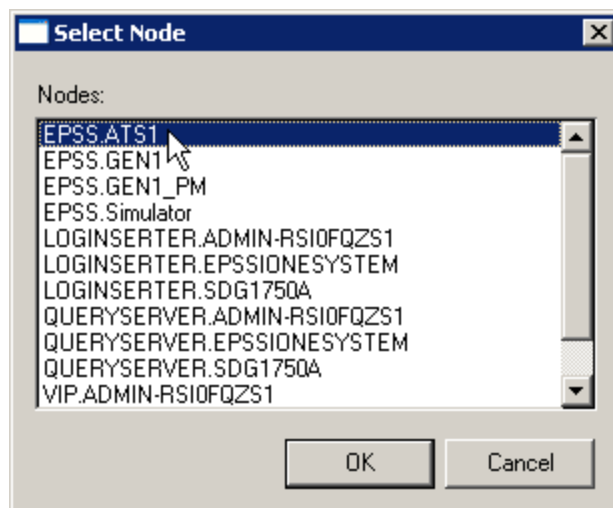

4. Navigate to **Advanced Setup** and double-click the **Frameworks** folder to open it.

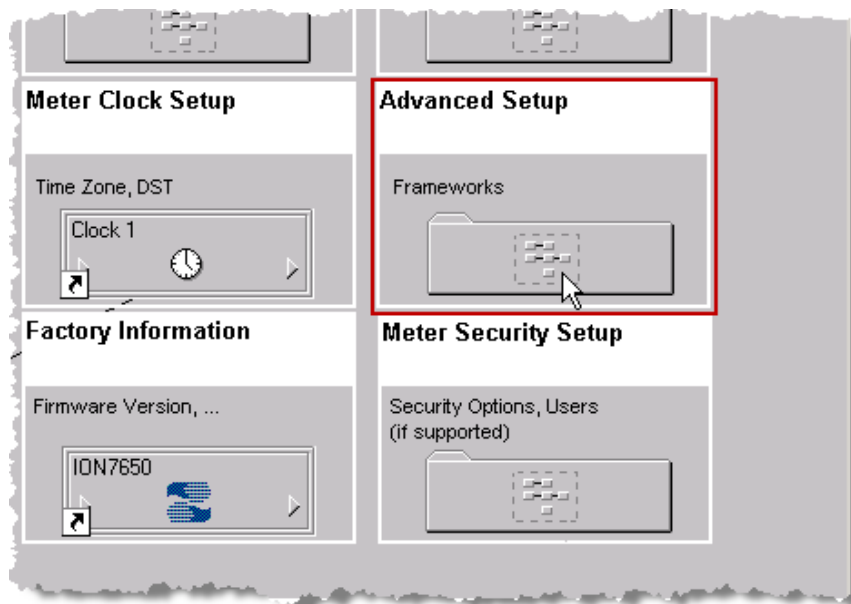

5. Make sure that the Toolbox is open. Select **Options > Show Toolbox** if it is not open.
6. Select **Edit > Paste from framework**. The **Paste from framework** window appears, from which you paste the framework to the **Frameworks – ION Advanced Configuration** folder.

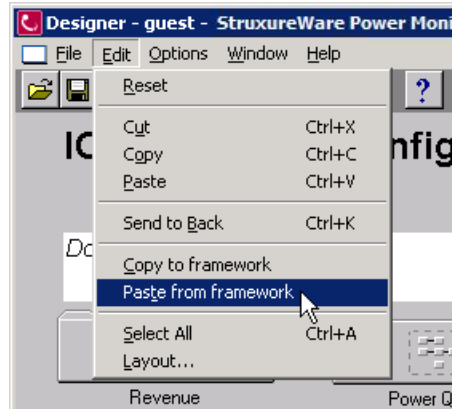

7. Navigate to C:\Program Files (x86)\Schneider Electric\Power Monitoring Expert for Healthcare\config\fmwk\EPSS, select the EPSS ATS framework .fwn file, and click **Open**.

For example, in the following image the EPSS ATS framework file is EPSS ATS.fwn.

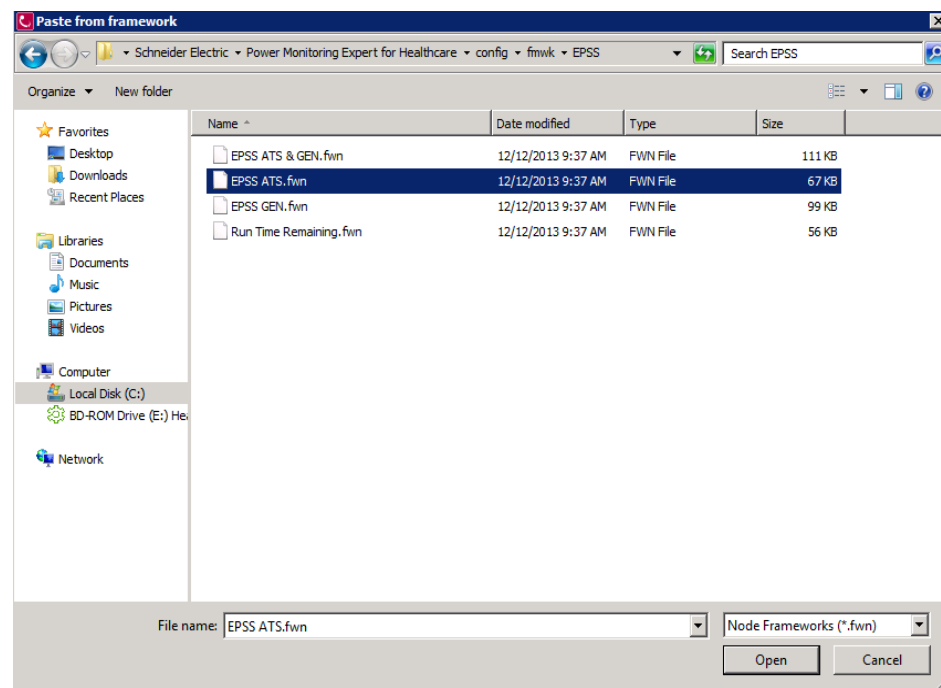

8. Press SHIFT and left-click to lock paste all of the Digital Input modules listed in the **Paste Summary** dialog, and free paste all of the remaining modules.

The lock paste overwrites a module if it already exists on the meter. For more information, see ["Deploying ATS Frameworks for EPSS" on page 182](#).

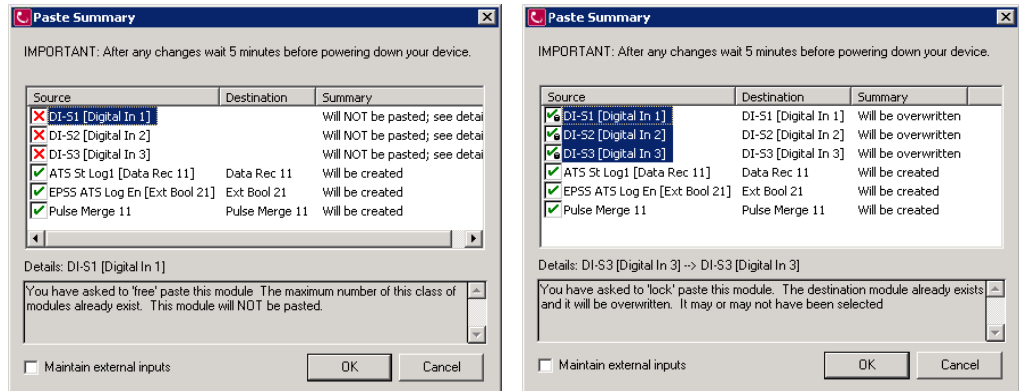

9. Do not select **Maintain external inputs**.
10. Press **OK** to paste the EPSS ATS framework.

## Configure the ATS Frameworks

After the EPSS ATS framework has been pasted, configure the EPSS ATS framework with site-specific data.

1. Double-click the framework folder **EPSS ATS** to open its node diagram.

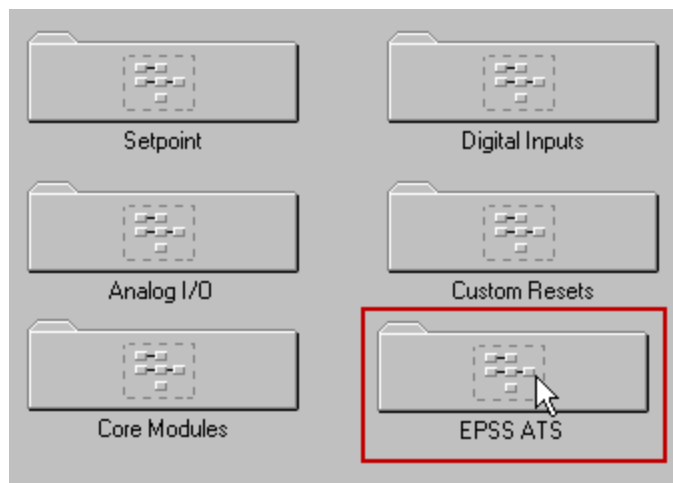

The nodes of the ATS framework, as shown next, support the three single state status signals: Normal, Emergency, and Test. These status signals are received by their respective digital input modules ATS1 Normal, ATS1 Emergency, and ATS1 Test.

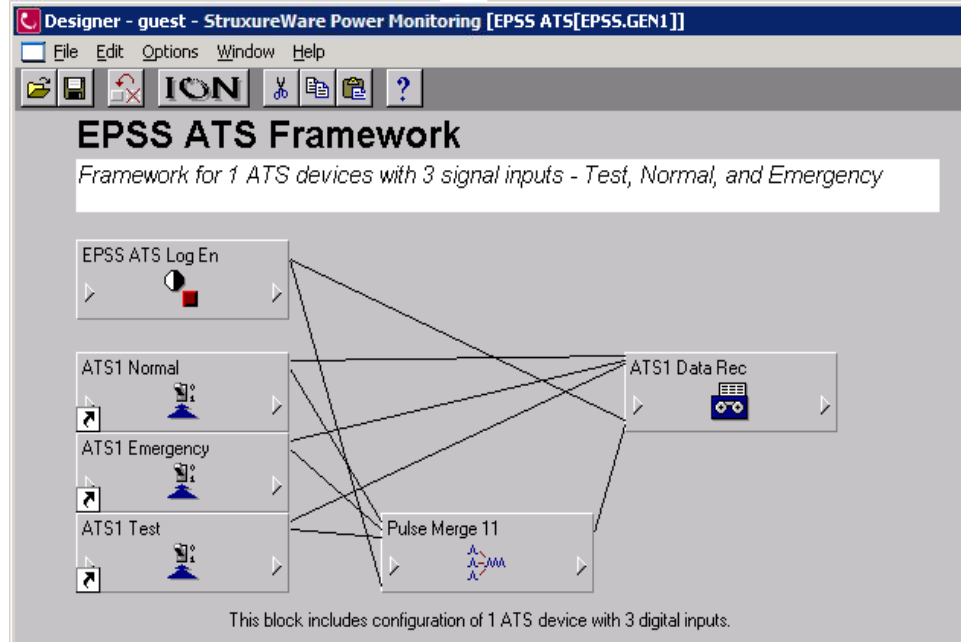

The names of the digital input modules are examples to identify how the label the components in the framework. You can rename them to match the system being deployed. For example, ATS1 could be just ATS. The remaining steps use these label names to illustrate the updates made to the framework.

2. Right-click a Digital Input module to access its registers. The **ION Module Setup** screen appears.

The following image shows the registers for the digital input module ATS1 Normal. The ATS controller hardware that this module interfaces with governs how *Input Mode*, *Polarity*, and *Debounce* should be configured.

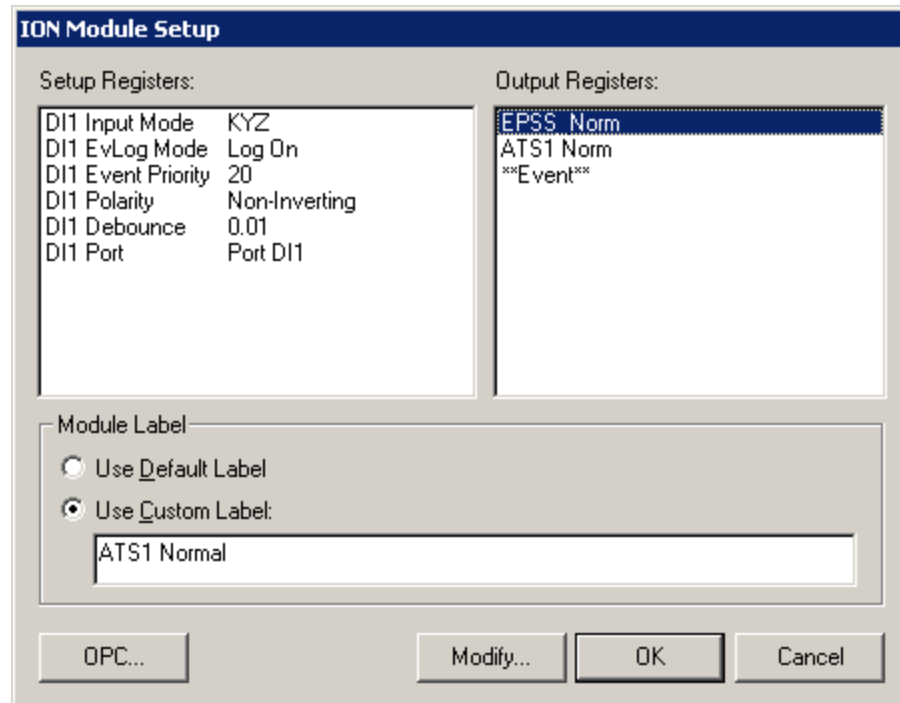

3. To update a register, select the register and click **Modify**. The **Modify Registers** screen appears.
4. Change the values to the site-specific sources and quantities. Click **OK** to return to the node diagram. For example:
  - The Setup Register *Input Mode* is set to KYZ, which forces a pulse output on both leading and trailing edges of the signal. This causes the data recorder to record the state on each transition of the signal.
  - The Output Register label `EPSS_Norm` is the name associated with the signal received by the digital input module AT51 Normal. The maximum number of characters for the label is 15. Examples of Output Register labels for digital input modules AT51 Emergency and AT51 Test are `EPSS_Emerg` and `EPSS_Test`, respectively.

Make sure that Output Register labels are consistently labeled across the entire system. For example, if you plan to represent the AT5 Normal state as `EPSS_Norm`, then you need to use the same label for all of the AT5s.

For systems that use a single meter to record EPSS status measurements for multiple EPSS devices, the Output Register naming convention for digital input modules must be modified from *quantity* to *quantity@source*.

For example, change `EPSS_Test` to `EPSS_Test@AT5xx` where *xx* uniquely identifies the AT5 device.

The *quantity@source* format allows the data it represents to be uniquely identified.

The quantities remain the same (EPSS\_Test, EPSS\_Emerg, EPSS\_Norm) but the source name is now unique (ATSxx). If this change is not made, data for all ATSS or generators recorded on the meter cannot be uniquely identified.

5. Right-click the Data Recorder module to access its setup registers.

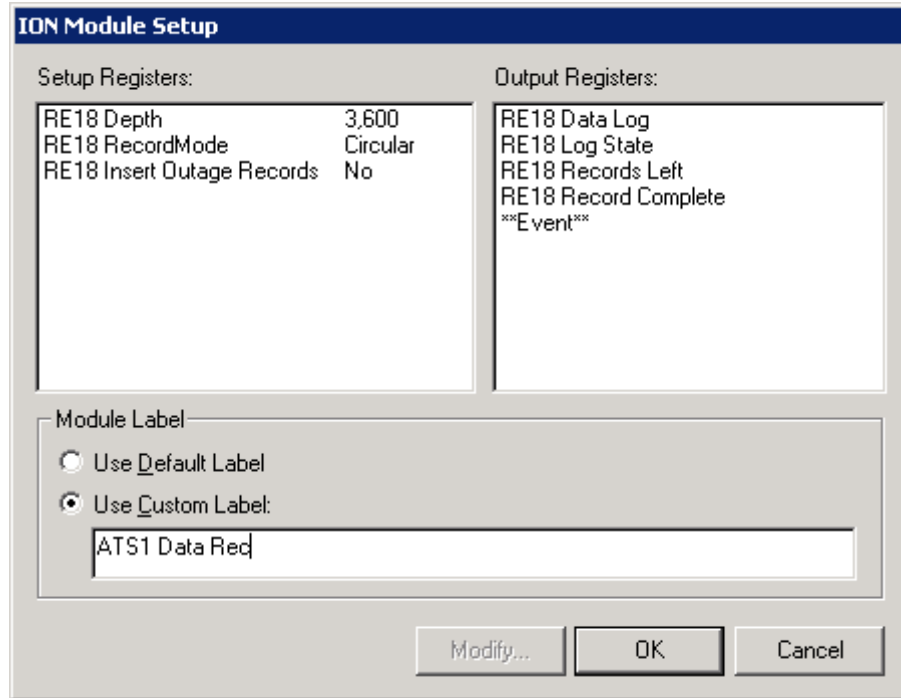

6. Set the *Depth* setup register to at least a value of 100 to help ensure that data is recorded.
7. Select **Use Custom Label** and add a label that clearly identifies the data recorder within the framework.
8. When you have completed all of the necessary site-specific modifications, click **File > Send & Save** from the node diagram to write your changes to the ION power meter.  
Refer to the *ION Reference* for more information about configuring setup registers.
9. Restart the Log Inserter Service after you configure the framework.

You can configure the EPSS ATS framework to remotely switch the ATS into test mode, as described next.

(Optional) If you have a power outage signal, feed it into the above module with the EPSS Normal Emergency and Test.

## Configure Remote ATS Test for ION7550/7650 Power Meter

Switching an ATS to test mode remotely is done by linking a control object in a Vista diagram to a digital output on the ION7550/7650 meter that is connected to the ATS controller.

Refer to *StruxureWare Power Monitoring Expert User Guide* for more instructions on working with Vista diagram control objects.

For details about configuring modules, refer to *ION Reference*.

**NOTE:** The EPSS ATS framework must be deployed to the meter and configured before you can set up the framework for ATS remote switching. For instructions, refer to "[Deploying ATS Frameworks for EPSS](#)" on page 182.

### Configure the Digital Output

Follow these steps to configure the digital output for the ION7550/7650 power meter.

1. Open Designer and login as a supervisor.
2. Connect to the meter.
3. In the meter framework, open the EPSS ATS folder.
4. From the Toolbox drag and drop an External Boolean module into the EPSS folder.
5. Locate the Digital Output folder and drag in a Digital Output module.

You can also use CTRL-SHIFT left click to drag in a shortcut to the Digital Output module.

The folder should look similar to the following example:

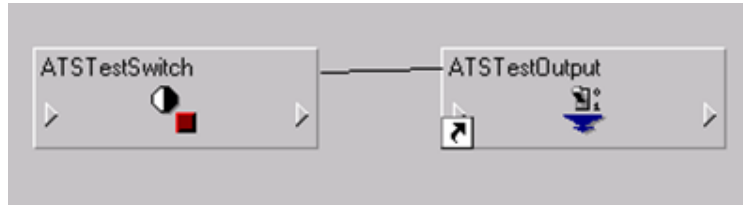

6. Configure the External Boolean Setup Registers as shown next:

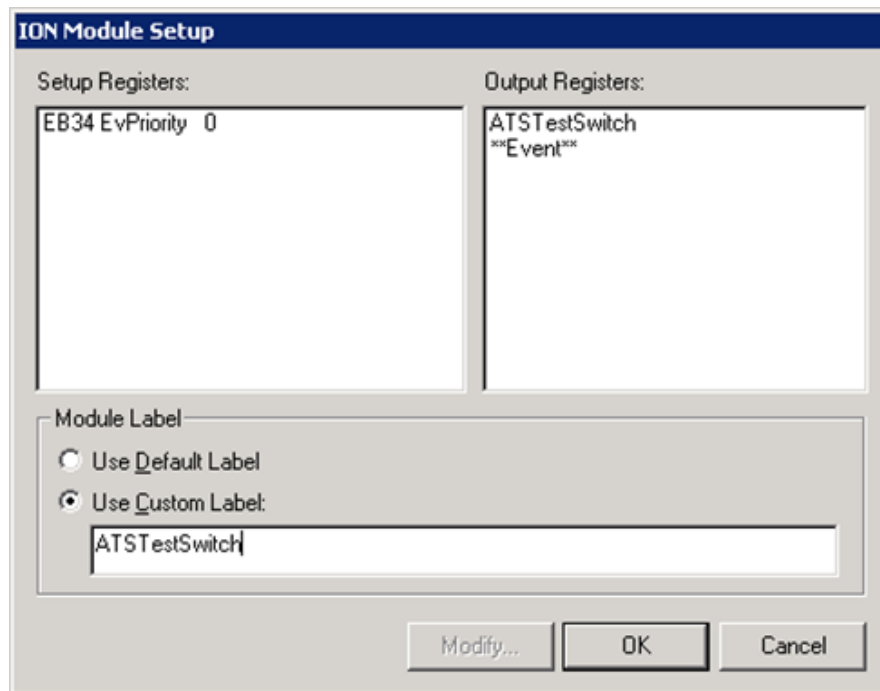

7. Connect the ATSTestSwitch output to the Source input of the Digital Output module, as shown next.

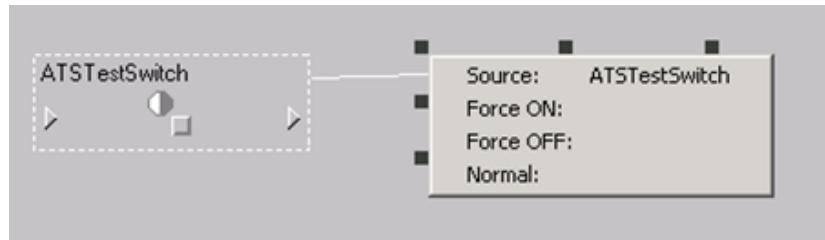

8. Configure the Digital Output module as shown next:

Note the following details for the module setup:

- **Polarity** - Set this to "Non-Inverting"
- **Pulse Width** - Set this to "0"
- **Port** - Set this to the physical port on the meter that is connected to the ATS. In this case, DO1.
- **Use Custom Label** - Enter a name easy to recognize, such as "ATSTestOutput."

9. Click the **Send and Save** icon.

Configure the Vista diagram for the meter, as described next.

### Configure the Vista Diagram

Follow these steps for the ION7550/7650 power meter. Make sure Designer is closed before linking any objects in Vista.

1. Login to Vista as a supervisor and open a new diagram.
2. From the Toolbox, drag a Control object onto the diagram.
3. Right-click on the Control object. The Control Object Configuration screen appears.
4. Use a custom label, such as "ATSTestSwitch."



5. Configure the link to the External Boolean module's Switch output register, as shown next.

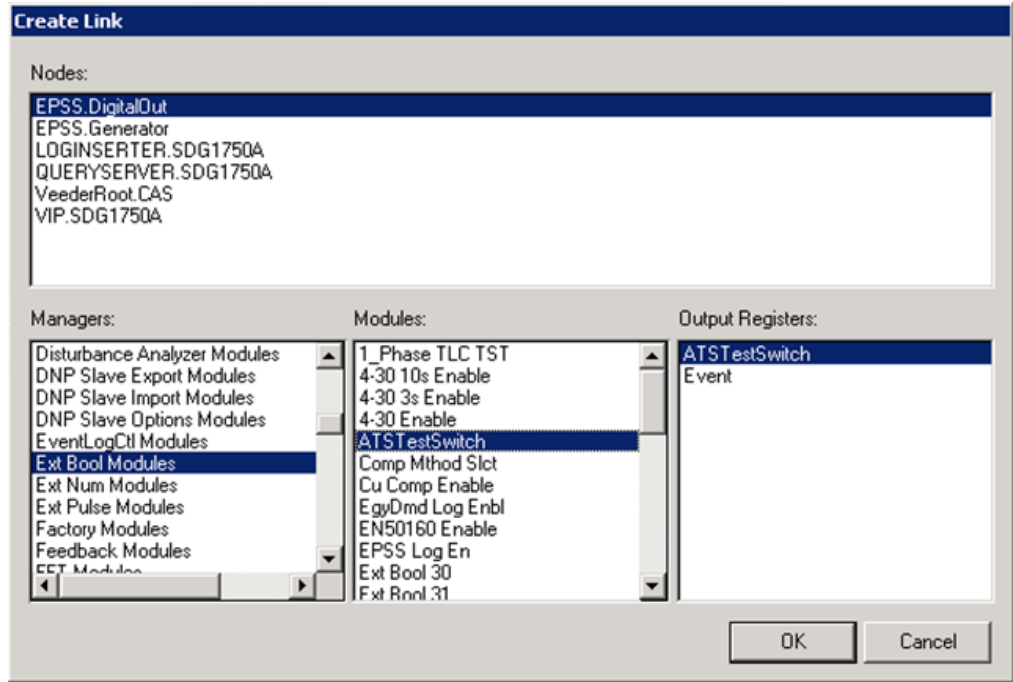

6. Click **OK**.
7. Right-click the ATSTestSwitch object. The Control Object Configuration screen appears.
8. On the **Action** tab, set the **Level to Operate** field to "Controller" as shown next.

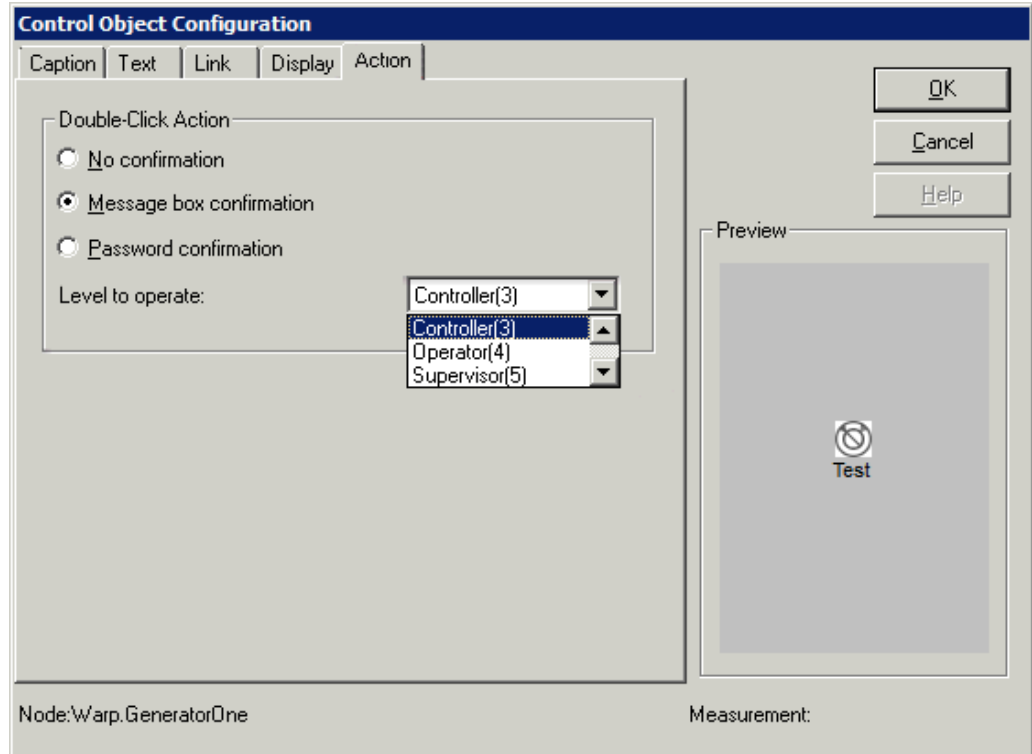

9. Click **OK**.
10. Close the Toolbox.
11. Restart the ION Log Inserter Service after you configure the framework.

Now you can control the ATS by clicking the switch.



## Deploying Generator Frameworks

### Overview

Use Designer to copy and paste the generator framework to the power meter. Repeat this process for every power meter in the system that records generator data for purposes. The generator framework is designed to capture generator status changes when they occur, and then to log generator-specific field data when the generator is active.

This framework is a template that should be adjusted to meet the requirements of your site. GEN Start or GEN Run can be used to initiate logging, and the frequency can be adjusted in the periodic timer.

- The status signals for status events GEN Start, GEN Run, and GEN Stop are recorded in the Gen State Log whenever any one of them changes state.

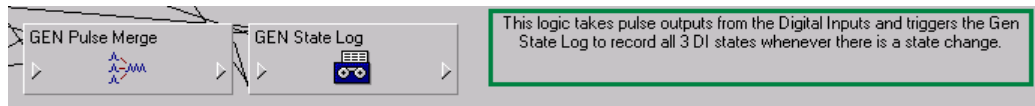

- The logic is designed to record analog and general electrical data when the generator is running. The data is logged at one minute intervals.

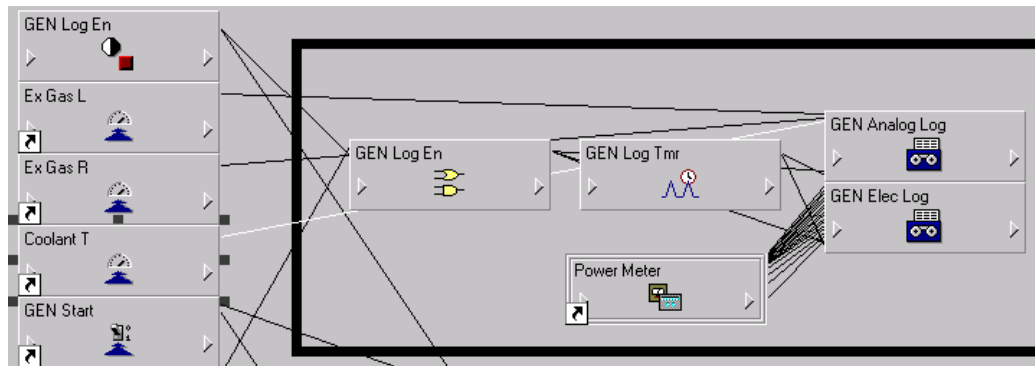

- The external Boolean Gen Log En must be linked to a control object in a Vista diagram and enabled before any data is logged. This allows users to notify the system that they are running a test and to log data accordingly.

## Pasting Generator Frameworks

Before you deploy generator frameworks, you need to be aware of the implications of free pasting and lock pasting modules.

Use free pasting to paste a new module with a different name if a module with the same name already exists. This helps to ensure that existing modules and their functionality are not replaced.

Use lock pasting to overwrite an existing module and its functionality with a new module, while retaining the module name. However, you need to understand what the modules are currently being used for before you lock paste the modules. A lock paste replaces the functionality of those modules.

- If a power meter already uses all modules of a certain type that are a necessary part of the framework, then a lock paste operation is required.
- If all of the available digital or analog input modules are in use, a lock paste of the analog or digital input modules is required to help ensure that the parameter settings are updated

## Copy Generator Framework to ION Power Meter

Use Designer to copy the generator framework to the power meter. Repeat this process for every power meter in the system that records generator data.

1. In **Management Console** click **Tools > System > Designer**. The Designer login window appears.
2. Enter the login credentials with administrator or supervisor access and click **OK**.

- Click **File > Open**, select the power meter that has the generator connected to it, and then click **OK** to open the meter's framework.

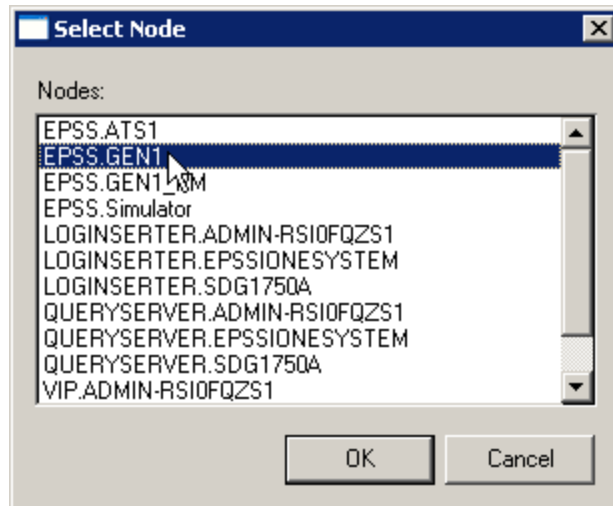

- Once the meter's framework is open, navigate to **Advanced Setup** and double-click the **Frameworks** folder to open it.

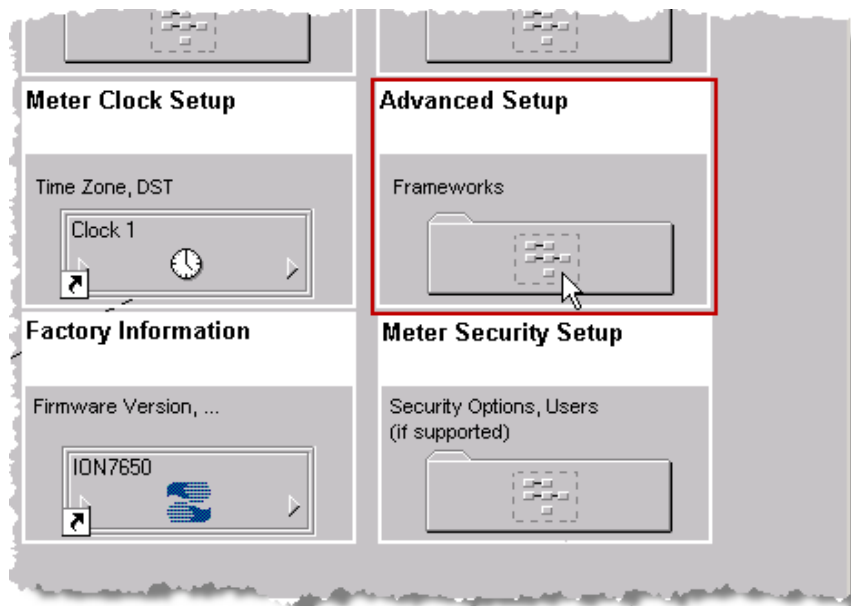

- Ensure that the Toolbox is open. Select **Options > Show Toolbox**, to open the Toolbox.
- Select **Edit > Paste from framework** to open the **Paste from framework** window, from which you paste the generator framework to the **Frameworks – SPM Advanced Configuration** folder.

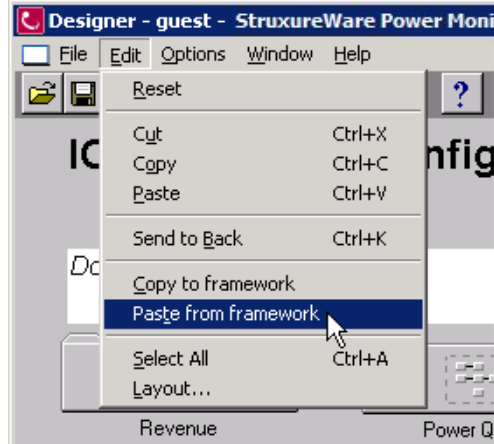

7. Navigate to ...\\Program Files (x86)\\Schneider Electric\\Power Monitoring Expert DC Ed\\config\\fmwk\\EPSS ...\\Program Files (x86)\\Schneider Electric\\Power Monitoring Expert for Healthcare\\config\\fmwk\\EPSS, select the generator framework . fwn file, and click **Open**.

For example, in the following image the generator framework file is EPSS GEN . fwn.

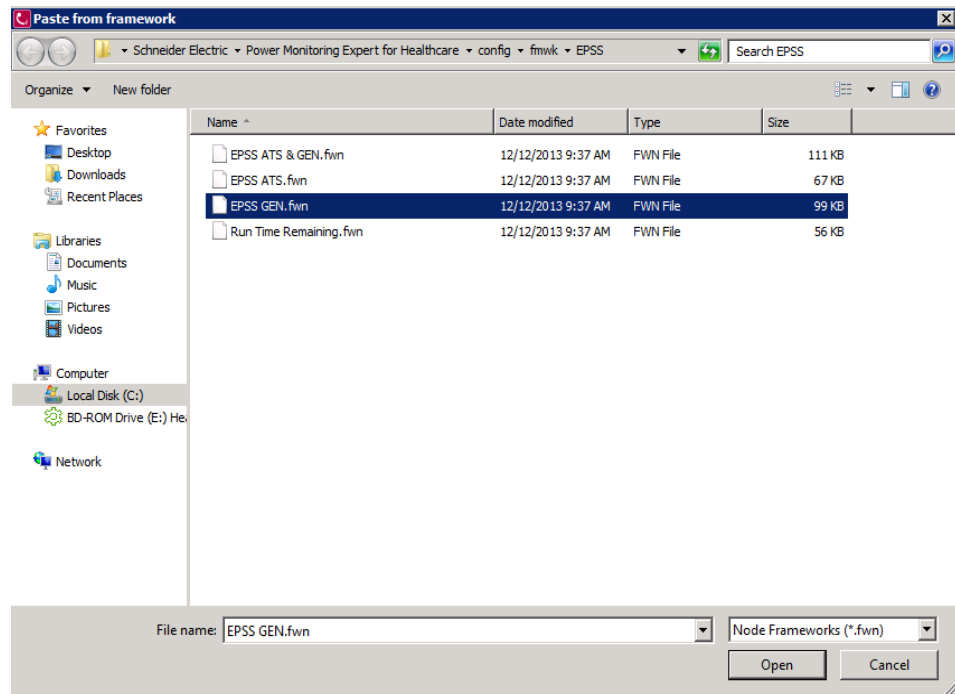

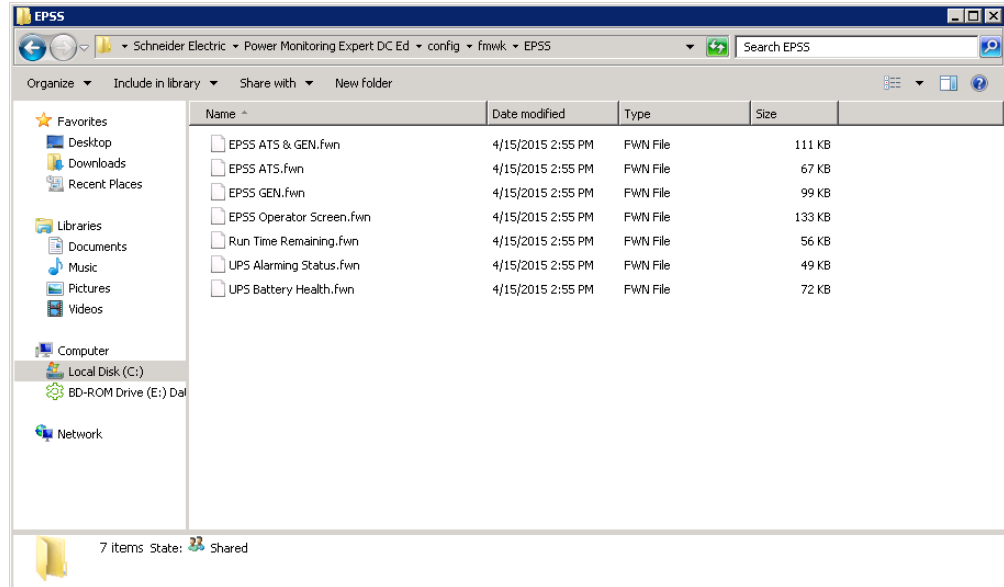

- Press **Shift** and left-click to lock paste all of the Analog Input and Digital Input modules listed in the **Paste Summary** dialog, and free paste all of the remaining modules.

The lock paste overwrites a module if it already exists on the meter. For additional information see ["Deploying ATS Frameworks for EPSS" on page 182](#).

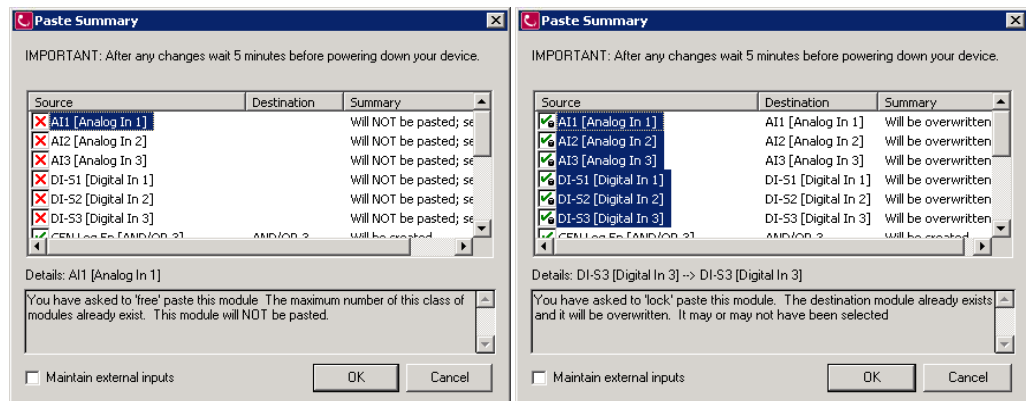

- Do not select **Maintain external inputs**.
- Press **OK** to paste the generator framework.

## Configure the Generator Framework

Configure the generator framework with site-specific data. Refer to the *ION Reference* for more information about configuring setup registers.

- After the generator framework has been pasted, double-click the folder **EPSS GEN** to open its node diagram.

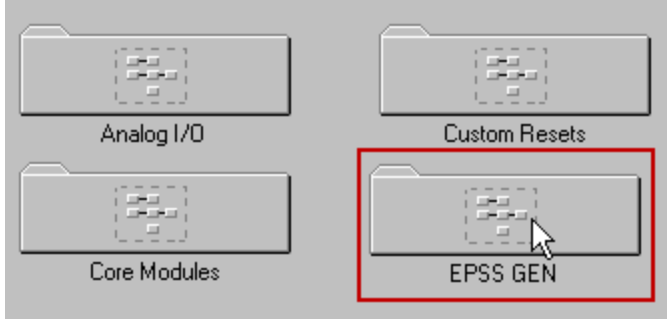

The nodes of the generator framework shown below support the three single state status signals: GEN Start, GEN Run, and GEN Stop. These status signals are received by their respective digital input modules GEN Start, GEN Run, and GEN Stop.

The names of the digital input modules are simply placeholders that are used as examples to identify how the components in the framework should be labeled. You can rename them to match the system being deployed. For example, GEN could be GEN1. The remaining descriptions in this section use these example labels to illustrate the updates made to the framework.

The framework also supports three analog signals. In the following image, these are Ex Gas L (exhaust gas left), Ex Gas R (exhaust gas right), and Coolant T (coolant temperature), and these signals are received by their respective analog input modules: Ex Gas L, Ex Gas R, and Coolant T. These module are examples only and they can be modified to any other parameters that need to be monitored and recorded.

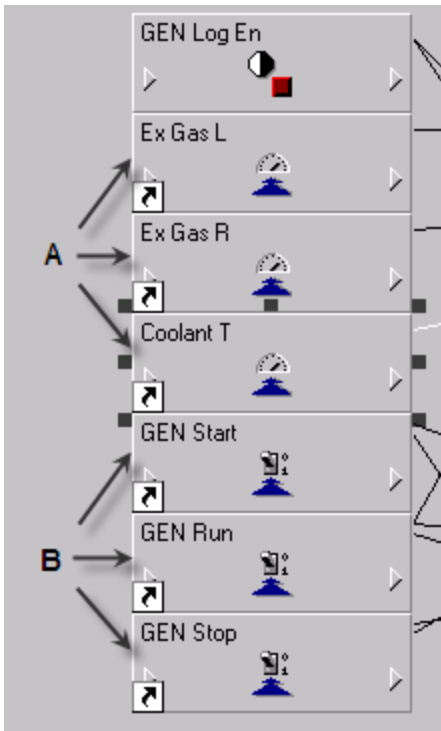

A. Analog Input Modules

B. Digital Input Modules

- Right-click a Digital Input module to access its setup registers. The following image shows the registers for the digital input module GEN Start. The generator controller hardware that this module interfaces with governs how it needs to be configured.

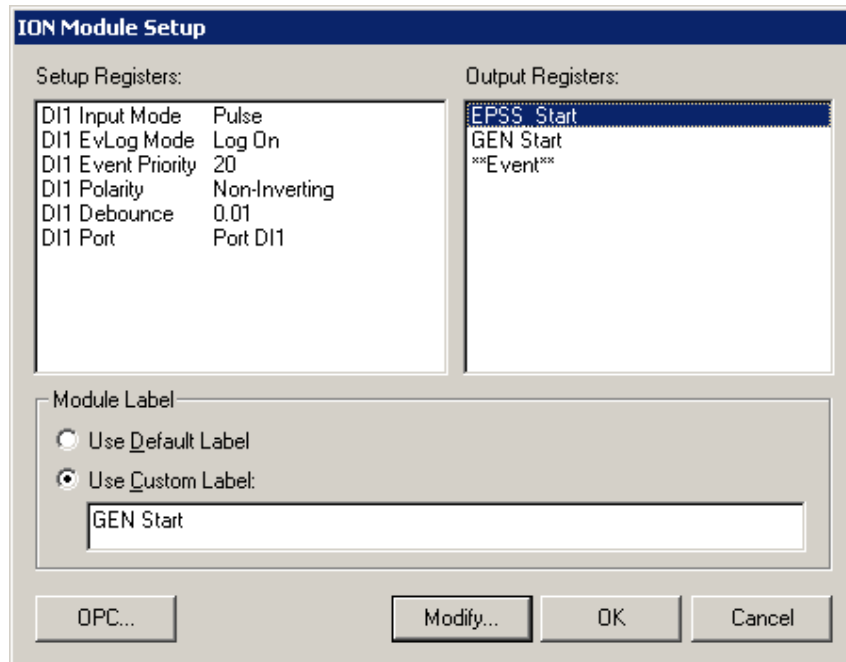

- To update a register, select the register and click **Modify**. The **Modify Registers** screen appears.
- Change the values to the site-specific sources and quantities, and click **OK** to return to the node diagram. For example:
  - The Setup Register *Input Mode* is set to KYZ, which forces a pulse output on both leading and trailing edges of the signal. This causes the data recorder to record the state on each transition of the signal.
  - The Output Register label `EPSS_Start` is the name associated with the signal received by the digital input module GEN Start. The maximum number of characters for the label is 15. Examples of Output Register labels for digital input modules GEN Run and GEN Stop are `EPSS_Run` and `EPSS_Stop`, respectively.

Make sure that Output Register labels are consistent across the entire system. For example, if you plan to represent the GEN Start state as `EPSS_Start`, then you need to use the same label for all of the generators.

Make sure that Output Register labels are consistent across the entire system. For example, if you plan to represent the GEN Normal state as `EPSS_Norm`, then you need to use the same label for all of the generators.

For systems that use a single meter to record EPSS status measurements for multiple EPSS devices, the Output Register naming convention for digital input modules must be modified from *quantity* to *quantity@source*.

For example, change EPSS\_Test to EPSS\_Test@GENxx where xx uniquely identifies the generator device.

The *quantity@source* format allows the data it represents to be uniquely identified.

The quantities remain the same (EPSS\_Test, EPSS\_Emerg, EPSS\_Norm) but the source name is now unique (GENxx). If this change is not made, data for all generators recorded on the meter cannot be uniquely identified.

5. Right-click an Analog Input module to access its registers. Shown below are the registers for the analog input module Ex Gas L. The generator controller hardware that this module interfaces with governs how it needs to be configured.

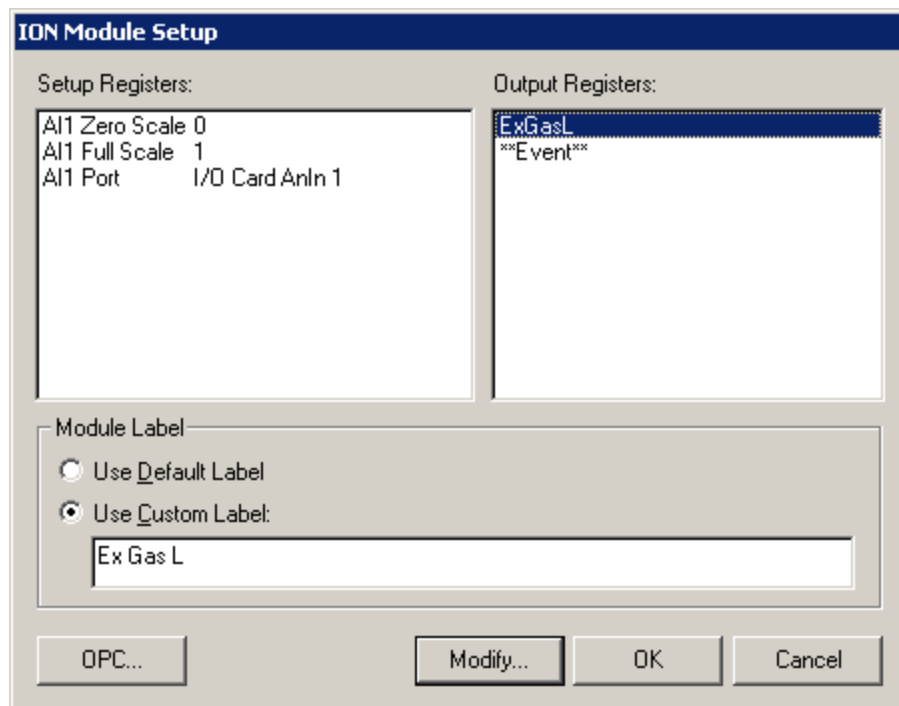

- The Output Register label ExGasL is the name associated with the signal received by the analog input module Ex Gas L. The maximum number of characters for the label is 15. Examples of Output Register labels for analog input modules Ex Gas R and Coolant T are ExGasR and CoolTemp, respectively.
  - Output Register labels should be consistent across the entire system. For example, if you plan to represent Exhaust Gas Left as ExGasL then you need to use the same label for all of the generators.
6. When you have completed all of the necessary site-specific modifications, click **File > Send & Save** from the node diagram to write your changes to the power meter.
  7. Restart the ION Log Inserter Service after configuring the generator frameworks.



# Non-ION Power Meter Configuration

This chapter section provides information about configuring non-ION power meters for the Power Monitoring Expert solution.

## WARNING

### UNINTENDED OPERATION

- Do not use the power meters for critical control or protection applications where human or equipment safety relies on the operation of the control circuit.
- Refer to your meter's technical documentation for more information on its operation.

**Failure to follow these instructions can result in death, serious injury, or equipment damage.**

## Supported Power Meters

Power Monitoring Expert can use the following non-ION power meters for the EPSS:

- PM800 series power meters. Refer to ["Configuring PM800 Series Meters" on page 202](#).
- PowerLogic Circuit Monitor Series 3000 and 4000 Power Meters. Refer to ["Configuring CM3000 and CM4000 Series Meters" on page 220](#).
- Momentum PLC. Refer to ["Configuring Momentum PLC" on page 239](#).

### Supported Sequence of Event Recorders

- SER-2408/SER-3200. Refer to ["Adding the SER-2408/SER-3200 to Management Console" on page 252](#).

## Prerequisites

The following prerequisites must be completed before attempting to configure a non-ION power meter to record data from generators and other equipment for the EPSS:

- Power Monitoring Expert is installed and operational.
- All meters must be installed and communicating.
- The following status signals for each ATS are physically wired to the digital inputs on the appropriate meters.
  - Normal
  - Emergency
  - Test
  - Power Outage (optional)
- The following status signals for each generator are physically wired to the digital inputs on the appropriate meters.

- Start (optional)
  - Emergency Power Source Available (optional)
  - Run
  - Stop
- The following generator electrical data are metered and available for each generator:
    - Currents: A, B, C, N, Avg
    - Minimum Apparent Power Total
    - Minimum Real Power Total
    - Frequency
    - Real Power Total
    - Apparent Power Total
    - Voltages: A-B, B-C, C-A, L-L Avg, A-N, B-N, C-N, L-N Avg
  - The following signals for each generator are physically wired to the analog inputs on the appropriate meters. The number of analog inputs required depends on how many measurements are being recorded. For example, analog data can include the following:
    - Exhaust Gas Temperature left and right
    - Engine Coolant Temperature in and out.
    - Engine Oil Pressure

## Configuring PM800 Series Meters

This chapter describes how to use PowerLogic™ ION Setup to configure meters. This chapter does not explain how to add power meters to the system or how to use ION Setup.

- For information about adding meters to the system, refer to the Management Console online help or the Management Console section of the *StruxureWare Power Monitoring Expert User Guide*.
- For information about ION Setup software, refer to ION Setup online Help or the *PowerLogic ION Setup User Guide*.

For more information about configuring the PM800 series meters using ION Setup software:

- *Additional Device Support in ION Setup* in the ION Setup online help
- *PowerLogic ION Setup Device Configuration Guide*

You can configure the PM800 series meter for switching the ATS into test mode remotely. See "[Configure Auto-Enable Data Logs for CM4000 and PM800 series](#)" on [page 236](#) for instructions.

## Add PM800 Series Meters to a Site in ION Setup

Use ION Setup to add PM850 or PM870 meters to the site.

1. In the devices area, right-click and select **Insert Item**. The **New Network Item** screen appears.

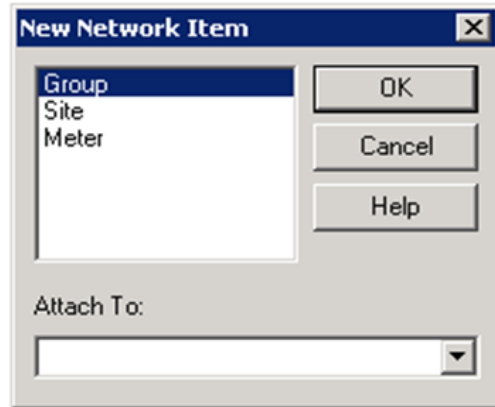

2. Select **Meter** and click **OK**. The **New Device** screen appears.
3. Select the **General** tab
4. In the **Type** list, select **PowerLogic PM800 Series Power Meter**.
5. Select the **Display** tab. In the **Template Options** box, select the type of meter you are adding.

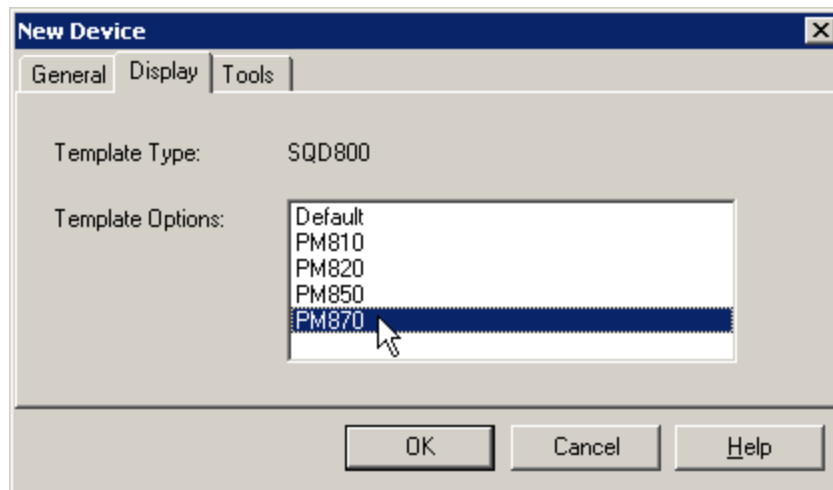

6. Click **OK** to add the meter.
7. In the Network Viewer (left pane), click the meter icon. The setup screens appear in the Content Viewer (right pane).

The following image shows a partial list of the setup screens. Use the **I/O Setup**, **Onboard Alarms/Events**, and **Data Log** setup screens to access the parameters that need to be configured. The remaining topics in this chapter describe the parameter changes that are required.

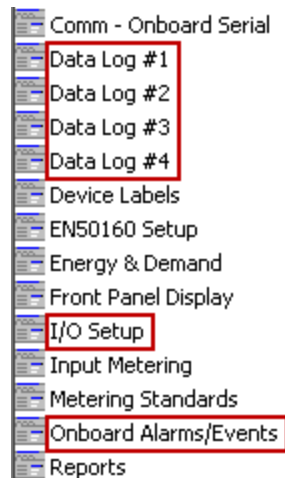

For more information about adding PM850 or PM870 meters to a site in ION Setup, refer to the following:

- ION Setup online Help
- *PowerLogic ION Setup Device Configuration Guide*, "PM800 series power meter" section
- *PowerLogic ION Setup User Guide*, "Adding and Configuring Devices" section

## Configuring Digital and Analog Inputs

This section describes how to configure the digital and analog inputs for the PM800 meters. The instructions assume that you are using separate PM800 series power meters to record data for ATSS and generators.

### **⚠ WARNING**

#### **UNINTENDED OPERATION**

- Do not use the meters for critical control or protection applications where human or equipment safety relies on the operation of the control circuit.
- Refer to your meter's technical documentation for more information on its operation.

**Failure to follow these instructions can result in death, serious injury, or equipment damage.**

#### **Configure Digital Inputs**

1. In the Content Viewer, double-click **I/O Setup** to access the Digital Inputs for the meter.
2. Select the I/O point that you want to configure and click **Edit**.

The following image shows **Digital In A-S1** selected.

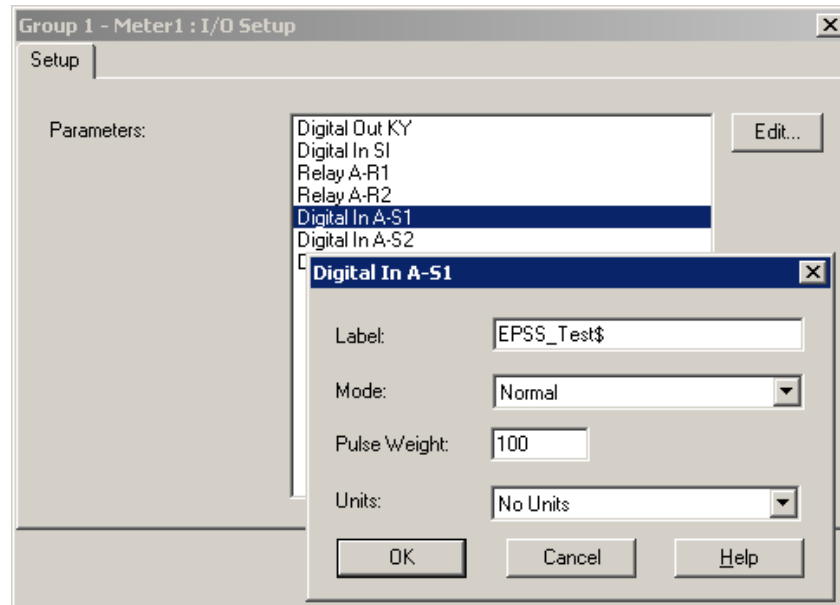

3. Update the **Label** field with a name that ends with the \$ character.  
The \$ character activates the translated device dynamic labeling feature. If the \$ character is not used, the default label is used.
  - For an ATS, examples of labels that conform to the naming convention are EPSS\_Test\$, EPSS\_Emerg\$, EPSS\_Norm\$, and EPSS\_Util\$.
  - For a generator, examples of labels are EPSS\_Start\$, EPSS\_Run\$, and EPSS\_Stop\$.
4. Set **Mode** to Normal, **Pulse Weight** to a non-zero value, for example 100, and leave **Units** set as No Units.
5. Click **OK** to update the parameters and to close the dialog.
6. Repeat the steps above for each I/O point that you want to configure.
7. Click **Send** to save the changes and send the configuration to the meter.

### Configure Analog Inputs

PM800 series power meter Analog Inputs are only available when you install the PM8M2222 Input/Output module on the meter.

Refer to the *Power Meter Input/Output Module PM8M2222, PM8M26, PM8M22 Installation Manual* for more information about installing the input/output module. Obtain this installation manual at [www.powerlogic.com](http://www.powerlogic.com). Select the country, and then **Energy and Power Quality Meters > PowerLogic Multifunction Power Meters > PM800 Series > Downloads > Tech Publications**.

1. In the Content Viewer, double-click **I/O Setup** to access the Analog Inputs for the meter.
2. Select the I/O point that you want to configure and click **Edit**.  
The following image shows **Analog In A-A11** selected.

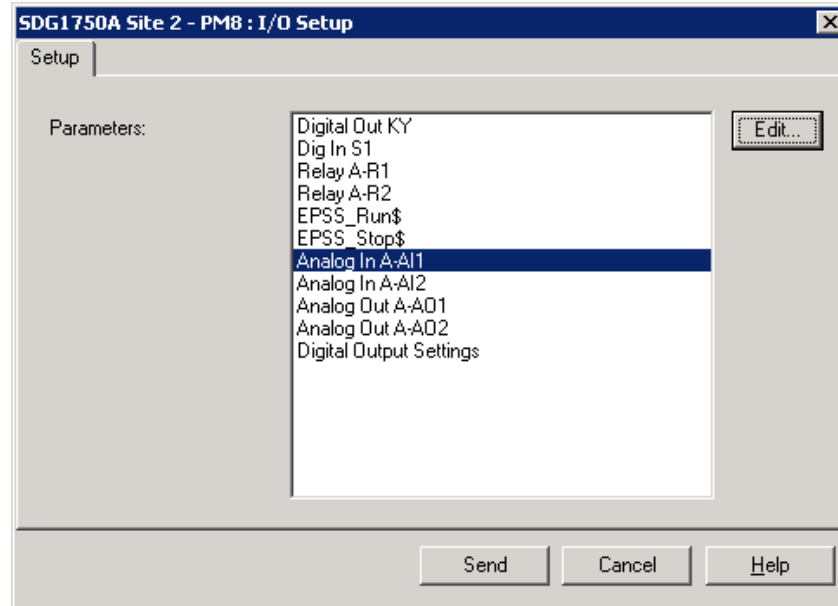

3. Click **Edit** to open the parameter window for the I/O point and update the **Label** field with a name that ends with the \$ character.

For a generator, examples of labels for analog inputs are Exhaust Gas L\$, Exhaust Gas R\$, and Coolant T\$.

The following image shows the label updated to Exhaust Gas L\$.

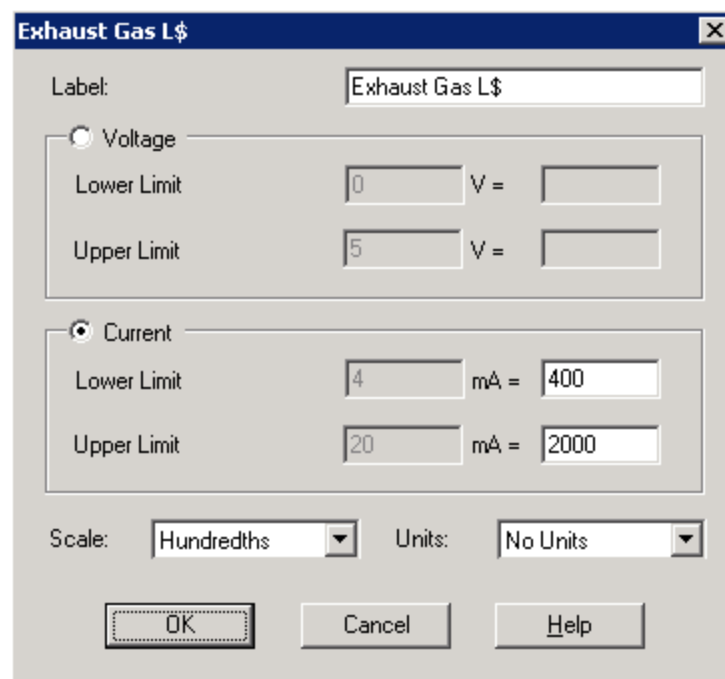

4. Click **OK** to update the parameters and to close the dialog.
5. Repeat the steps above for each I/O point that you want to configure.
6. Click **Send** to save the changes and send the configuration to the meter.

## Configuring Onboard Alarms and Events

For each digital input configured in I/O Setup, you need to configure the alarms to record when the digital input on an ATS or a generator changes from OFF to ON, and also from ON to OFF.

### Configure Digital Input Alarms for ATSS

This section assumes that you configured digital inputs **Digital In A-S1** as EPSS\_Test\$, **Digital In A-S2** as EPSS\_Emerg\$, and **Digital In A-S3** as EPSS\_Norm\$. You must configure an alarm for the digital input change from OFF to ON and from ON to OFF.

#### Digital input change from OFF to ON

Complete the following steps to configure an alarm when a digital input changes from OFF to ON.

1. In the Content Viewer, double-click **Onboard Alarms/Events** to open the **Setup** dialog.
2. Select **Digital** and click **Edit** to open the **Digital Alarm Setup** dialog.
3. Select one of the Digital Input/Output points.

The following figure shows the **Digital In A-S1** input selected and its label EPSS\_Test\$.

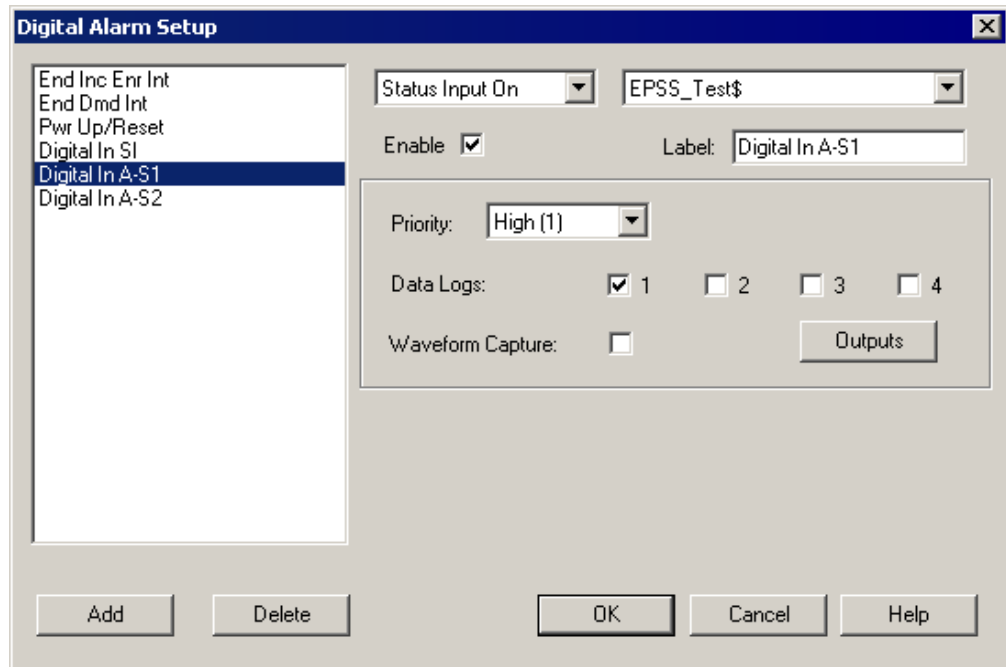

4. Select **Status Input On** from the list to set the alarm when the digital input changes from OFF to ON.
5. Make sure that **Enable** is selected.
6. In the **Label** field, change the digital alarm name from **Digital In A-S1** to **Test ON**.

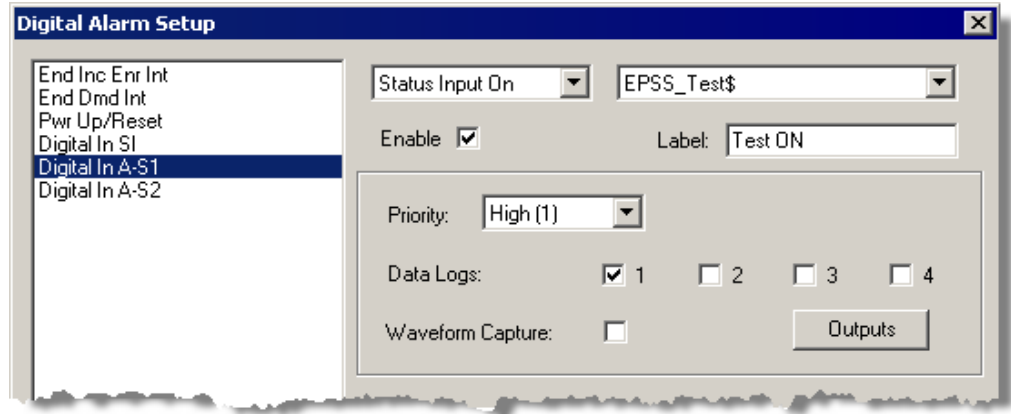

7. Set **Priority** to High(1), and select Data Log 1 as the data log to use. Select **Waveform Capture** if you want to trigger a waveform capture on alarm.

When the status for EPSS\_Test\$ changes to ON, Data Log 1 records all channels currently configured on it.

#### Digital input change from ON to OFF

Complete the following steps to configure an alarm when a digital input for EPSS\_Test\$ changes from ON to OFF.

1. Click **Add** to add another digital input alarm parameter to the list in the left pane of the **Digital Alarm Setup** dialog.

If the 12 available digital input alarms have been configured, you need to re-configure an existing alarm for the ON to OFF status change.

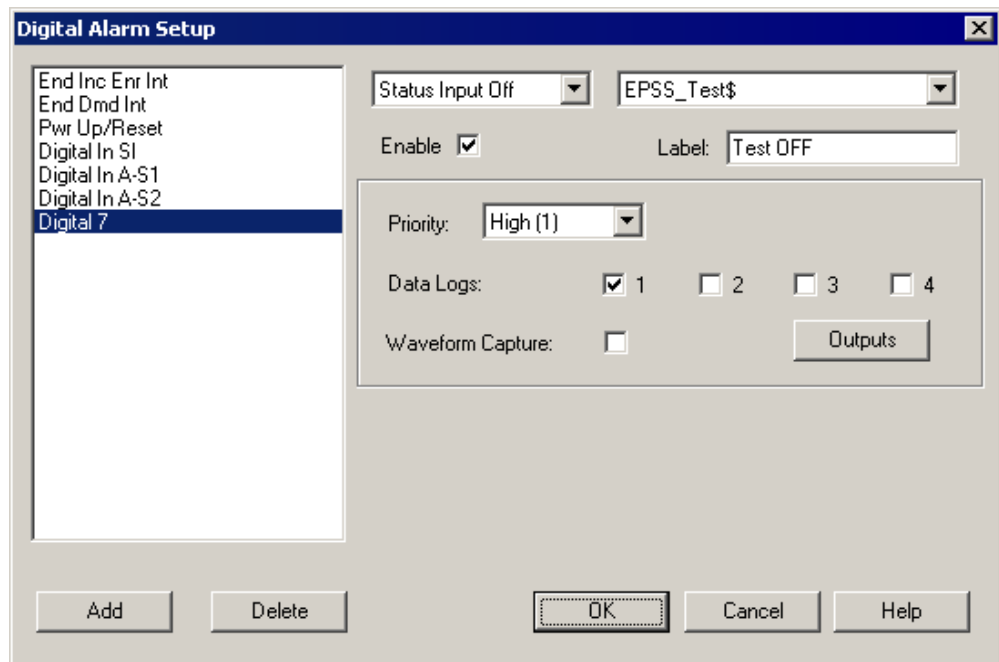

2. Select **Status Input Off** from the list to set the alarm when the digital input changes from ON to OFF.

3. Select `EPSS_Test$` from the list.
4. Make sure that **Enable** is selected.
5. In the **Label** field, change the digital alarm name to **Test OFF**.
6. Set **Priority** to High(1), and select Data Log 1 as the data log to use. Select **Waveform Capture** if you want to trigger a waveform capture on alarm.
7. Repeat the steps above to configure alarms for digital input changes from OFF to ON and from ON to OFF for all of the applicable I/O points.

The following table summarizes the configuration of the alarms, assuming that the I/O points are Digital In A-S1, Digital In A-S2, and Digital In A-S3:

Digital Input Label	Maps to	Alarm Status	Alarm Name
EPSS_Test\$	Digital In A-S1	Status Input On	Test ON
EPSS_Test\$	Digital In A-S1	Status Input Off	Test OFF
EPSS_Emerg\$	Digital In A-S2	Status Input On	Emerg ON
EPSS_Emerg\$	Digital In A-S2	Status Input Off	Emerg OFF
EPSS_Norm\$	Digital In A-S3	Status Input On	Normal ON
EPSS_Norm\$	Digital In A-S3	Status Input Off	Normal OFF

8. Click **OK** to close the dialog.
9. Click **Send** to save the changes and send the configuration to the meter.

### Configuring Digital Input Alarms for Generators

This section assumes that you configured digital inputs **Digital In A-S1** as `EPSS_Start$`, **Digital In A-S2** as `EPSS_Run$`, and **Digital In A-S3** as `EPSS_Stop$`. You must configure an alarm for the digital input change from OFF to ON and from ON to OFF.

#### EPSS\_Start\$: Digital input change from OFF to ON

Complete the following steps to configure an alarm when a digital input changes from OFF to ON.

1. In the Content Viewer, double-click **Onboard Alarms/Events** to open the **Setup** dialog.
2. Select **Digital** and click **Edit** to open the **Digital Alarm Setup** dialog.
3. Select one of the Digital Input/Output points.

The following figure shows the **Digital In A-S1** input selected and its label `EPSS_Start$`

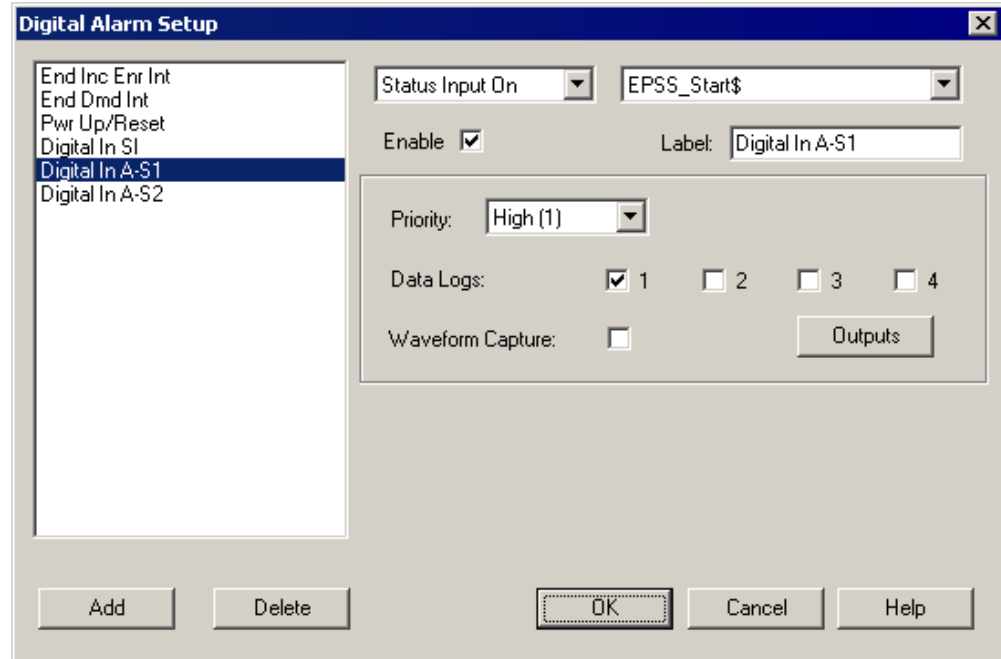

4. Select **Status Input On** from the list to set the alarm when the digital input changes from OFF to ON.
5. Make sure that **Enable** is selected.
6. In the **Label** field, change the digital alarm name from **Digital In A-S1** to **Start ON**.

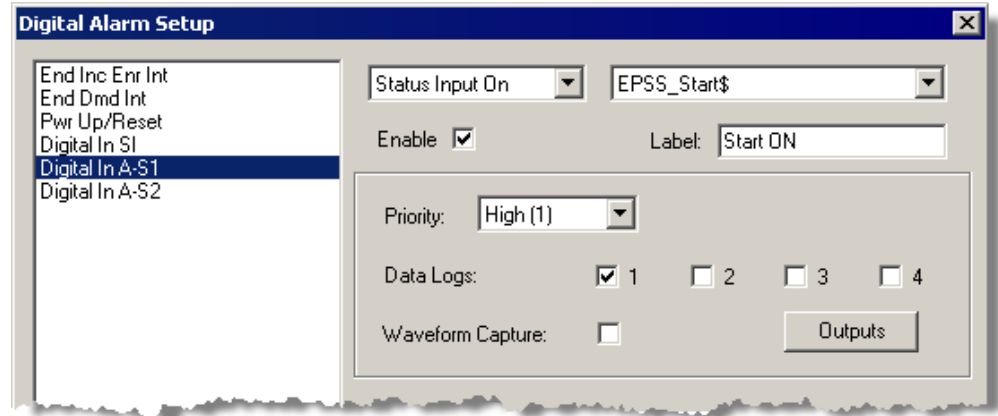

7. Set **Priority** to High(1), and select Data Log 1 as the data log to use. Select **Waveform Capture** if you want to trigger a waveform capture on alarm.

When the status for EPSS\_Start\$ changes to ON, Data Log 1 records all channels currently configured on it.

**EPSS\_Start\$: Digital input change from ON to OFF**

Complete the following steps to configure an alarm when a digital input for EPSS\_Start\$ changes from ON to OFF.

1. Click **Add** to add another digital input alarm parameter to the list in the left pane of the **Digital Alarm Setup** dialog. **NOTE:** If the 12 available digital input alarms have been configured, you need to re-configure an existing alarm for the ON to OFF status change.

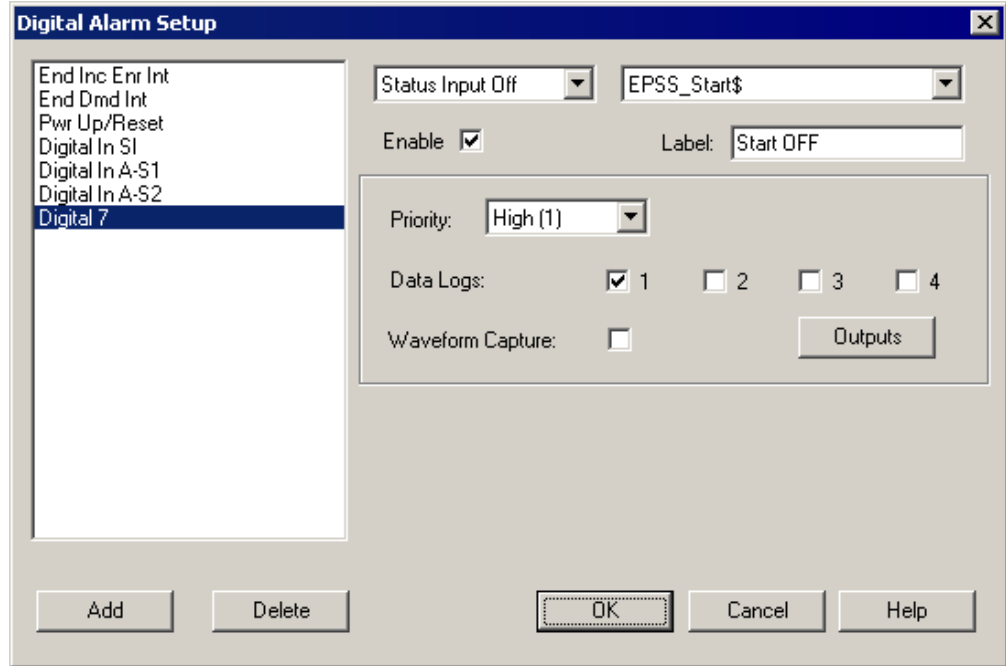

2. Select **Status Input Off** from the list to set the alarm when the digital input changes from ON to OFF.
3. Select EPSS\_Start\$ from the list.
4. Make sure that **Enable** is selected.
5. In the **Label** field, change the digital alarm name to **Start OFF**.
6. Set **Priority** to High(1), and select Data Log 1 as the data log to use. Select **Waveform Capture** if you want to trigger a waveform capture on alarm.
7. Repeat the steps above to configure alarms for digital input changes from OFF to ON and from ON to OFF for all of the applicable I/O points.

The following table summarizes the configuration of the alarms, assuming that the I/O points are Digital In A-S1, Digital In A-S2, and Digital In A-S3:

Digital Input Label	Maps to	Alarm Status	Alarm Name
EPSS_Start\$	Digital In A-S1	Status Input On	Start ON
EPSS_Start\$	Digital In A-S1	Status Input Off	Start OFF
EPSS_Run\$	Digital In A-S2	Status Input On	Run ON
EPSS_Run\$	Digital In A-S2	Status Input Off	Run OFF

Digital Input Label	Maps to	Alarm Status	Alarm Name
EPSS_Stop\$	Digital In A-S3	Status Input On	Stop ON
EPSS_Stop\$	Digital In A-S3	Status Input Off	Stop OFF

8. Click **OK** to close the dialog.
9. Click **Send** to save the changes and send the configuration to the meter.

#### Define a Digital Alarm for a Single Digital Input

If a single digital input is used to record signals indicating when the generator is running, and also when the generator has stopped, you need to define the digital alarm as follows.

1. In the **Digital Alarm Setup** dialog, select the Digital Input/Output point that will be used to record the alarm. For example, if you configured **Digital In A-S1** with a label of EPSS\_Run\$, select this I/O point.
2. Select **Status Input On** from the list to set the alarm when the digital input changes from OFF to ON.
3. Make sure that **Enable** is selected.
4. In the **Label** field, change the digital alarm name from **Digital In A-S1** to **Run ON**.
5. Set **Priority** to High(1), and select Data Log 1 as the data log to use.

#### EPSS\_Run\$: Digital input change from ON to OFF

1. Click **Add** to add another digital input alarm parameter to the list in the left pane of the **Digital Alarm Setup** dialog.
2. Select **Status Input Off** from the list to set the alarm when the digital input changes from ON to OFF.
3. Select EPSS\_Run\$ from the list.
4. Make sure that **Enable** is selected.
5. In the **Label** field, change the digital alarm name to **Stop ON**.
6. Set **Priority** to High(1), and select Data Log 1 as the data log to use.
7. Click **OK** to close the dialog.
8. Click **Send** to save the changes and send the configuration to the meter.

As a result of this alarm configuration where EPSS\_Run\$ represents both the Running and Stopped states for the generator, when **Run ON** is TRUE, the signal is recorded as "1", and when **Stop ON** is TRUE, the signal is recorded as "0".

## Defining the Data Log Parameters

This section explains how to define data log parameters for the digital inputs, analog inputs, and load profile data. The instructions assume that you use Data Logs 1 and 2. However, you can use any Data Log that meets your requirements.

### Define Data Log Parameters for Digital Inputs

Complete the following steps to define the data log parameters for the digital inputs.

1. In the Content Viewer, double-click **Data Log #1** to open the **Setup** dialog for the data log parameters.
2. Set **Status** to Enable and **Interval** to Only On Event. The Only On Event mode appears as 0 in the **Interval** field of the **Setup** dialog.
3. Select **Channels**, click **Edit**. The Parameter Selection dialog appears.

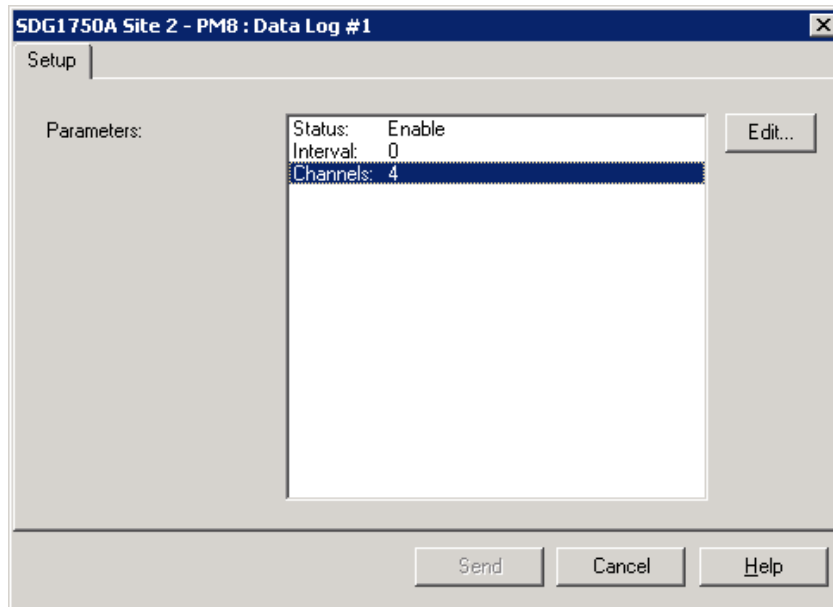

4. In the **Available** box, navigate to **Inputs/Outputs** and select a custom label, such as EPSS\_Emerg\$.
5. Select the **IO Point xx Digital State**, where xx is the number of the I/O point present on the meter. Click >> to move the parameter to the **Selected** box.

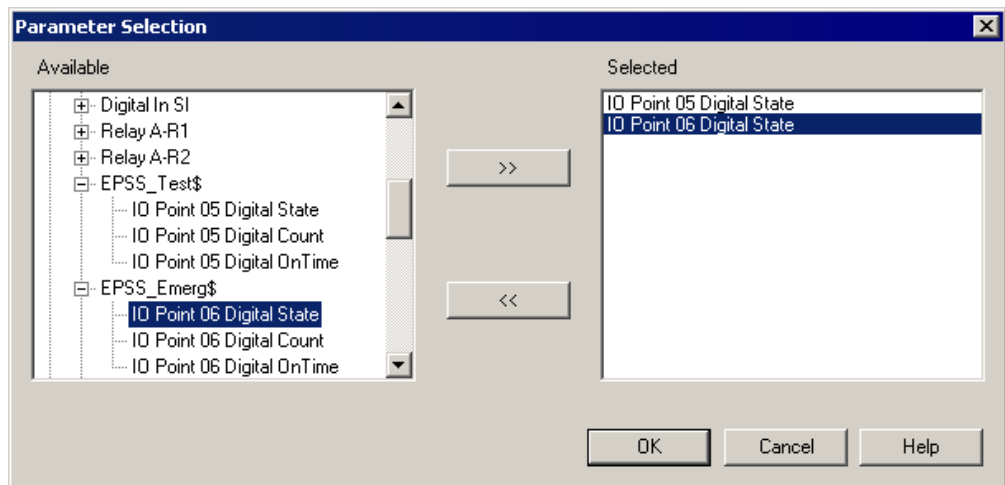

6. Repeat steps 4 - 5 for all I/O points available for the ATS or generator.

7. In the **Available** box, expand **Miscellaneous** and select **Present MilliSeconds**. Click **>>** to move it to the **Selected** column.

Add all I/O points for a given ATS or generator to the data log to help ensure that all of the states are recorded in the data log when any state changes.

8. Click **OK** to close the dialog.
9. Click **Send** to save the changes and send the configuration to the meter.

#### **Define Data Log Parameters for Analog Inputs and Load Profile Data**

Configure the system to log the analog inputs and load profile data automatically when the generator state changes to Running. When the generator state is Running, the alarm status for digital input EPSS\_Run\$ is ON.

Using ION Setup, the process to configure automatic logging is:

1. Associate Data Log 2 with the digital input alarm **Run ON** that you previously defined for EPSS\_Run\$.
2. Select the parameters for the Analog Input data to be logged in Data Log 2.
3. Select the parameters for the Load Profile data to be logged in Data Log 2.
4. Set the status of Data Log 2 to Auto-Enable.

These steps assume that you use Data Log 2.

#### **Associate Data Log 2 with the Digital Input Alarm Run ON**

1. In the Content Viewer, double-click **Onboard Alarms/Events** to open the **Setup** dialog.
2. Select **Digital** and click **Edit** to open the **Digital Alarm Setup** dialog.
3. Select the digital input alarm **Run ON** that was defined for I/O point EPSS\_Run\$. You previously selected Data Log 1 when you configured this digital input alarm for the generator.
4. In the **Data Logs:** group, select **2**. Now both **1** and **2** are selected.

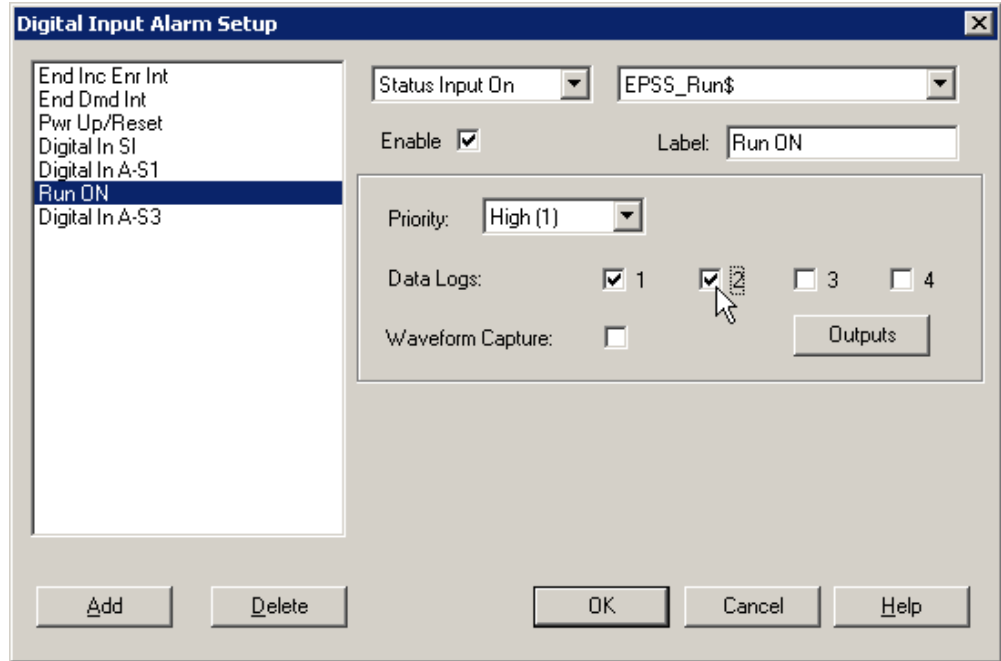

5. Click **OK** to close the dialog.
6. Click **Send** to save the changes and send the configuration to the meter.

**Select Parameters for Analog Input Data to be logged in Data Log 2**

1. In the Content Viewer, double-click **Data Log #2** to open the **Setup** dialog for the data log parameters.
2. Select **Interval** and click **Edit** to open the **Enter Logging Interval** dialog. Select **Continuous** from the list in **Mode**, set **Interval** to 1 minute, and click **OK** to close the dialog.

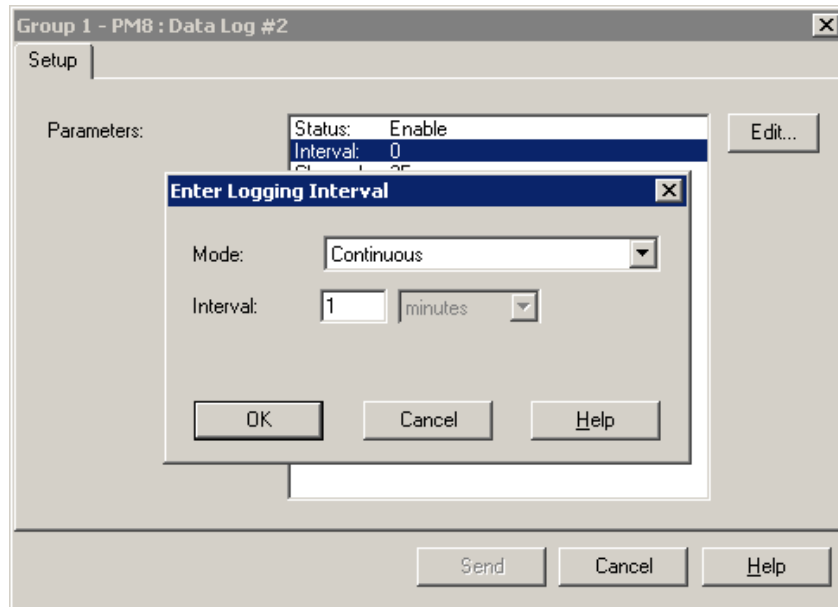

3. Select **Channels**, click **Edit**. The Parameter Selection dialog appears.

4. In the **Available** box, navigate to **Inputs/Outputs** and select a custom label, such as Exhaust Gas L\$.
5. Under **Analog Input**, select the **IO Point xx Analog Input Value**, where xx is the number of the I/O point present on the meter. Click >> to move the parameter to the **Selected** box.

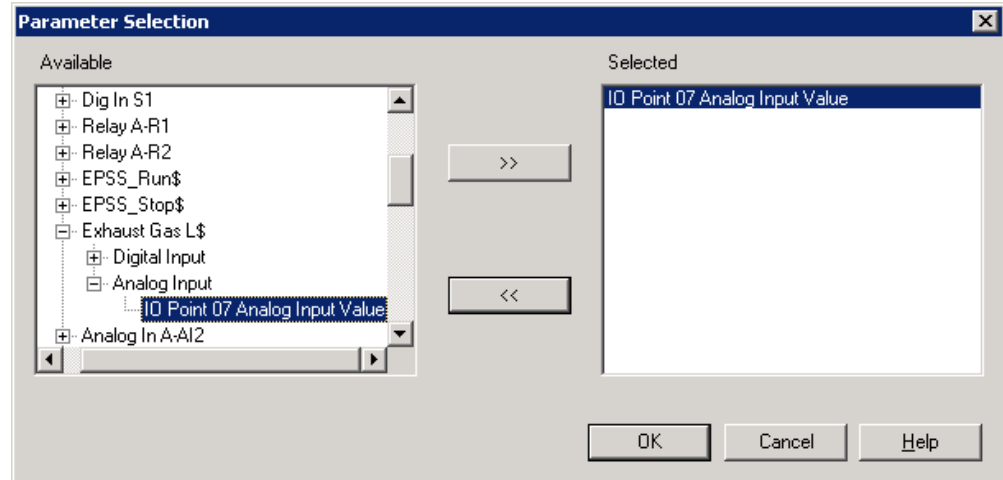

6. Repeat steps 4 - 5 for each analog input available for the generator.
7. Click **OK** to close the dialog.
8. Click **Send** to save the changes and send the configuration to the meter.

#### Select Parameters for Load Profile Data to be logged in Data Log 2

1. In the **Setup** dialog for Data Log 2, select **Channels** and click **Edit**. The **Parameter Selection** dialog appears.
2. Expand each of the following categories. Within each category select the parameters indicated. For each parameter click >> to move it to the **Selected** column:
  - a. In **Currents**, select Current A, Current B, Current C, Current N, and Current Avg.
  - b. In **Minimum Readings**, select Min Apparent Power Total, Min Real Power Total.
  - c. In **Miscellaneous**, select Frequency.
  - d. In **Powers**, select Real Power Total and Apparent Power Total.
  - e. In **Voltages**, select Voltage A-B, Voltage B-C, Voltage C-A, Voltage L-L Avg, Voltage A-N, Voltage B-N, Voltage C-N, and Voltage L-N Avg.

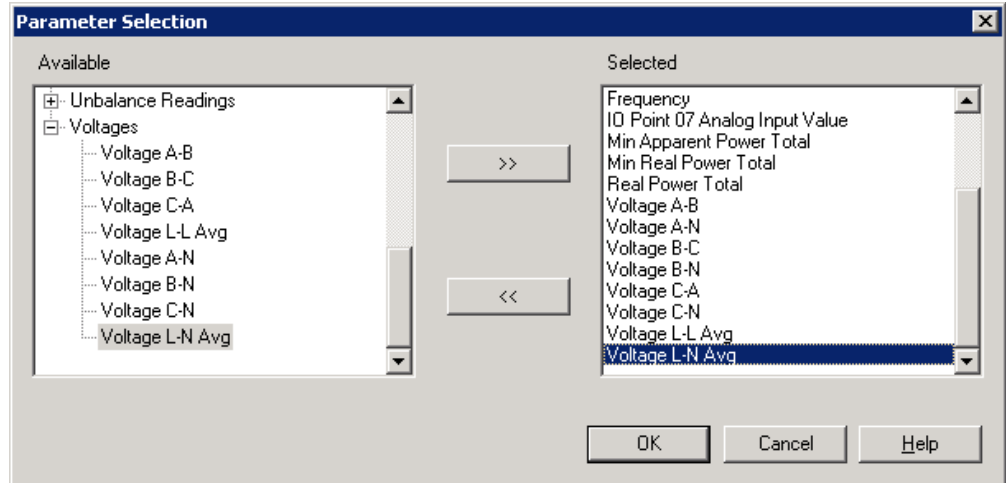

3. Click **OK** to close the dialog.
4. Click **Send** to save the changes and send the configuration to the meter.

**Set the Status of Data Log 2 to Auto-Enable**

Auto-Enable is a special mode that allows logging to be triggered when an alarm occurs. Data is recorded in the data log at a defined interval if the logging mode is set to **Continuous**. Logging stops when the alarm ends.

1. In the **Setup** dialog for Data Log 2, select **Status** and click **Edit**. The **Select Status** dialog appears.
2. In the drop-down list, select **Auto-Enable** and click **OK** to close the dialog.

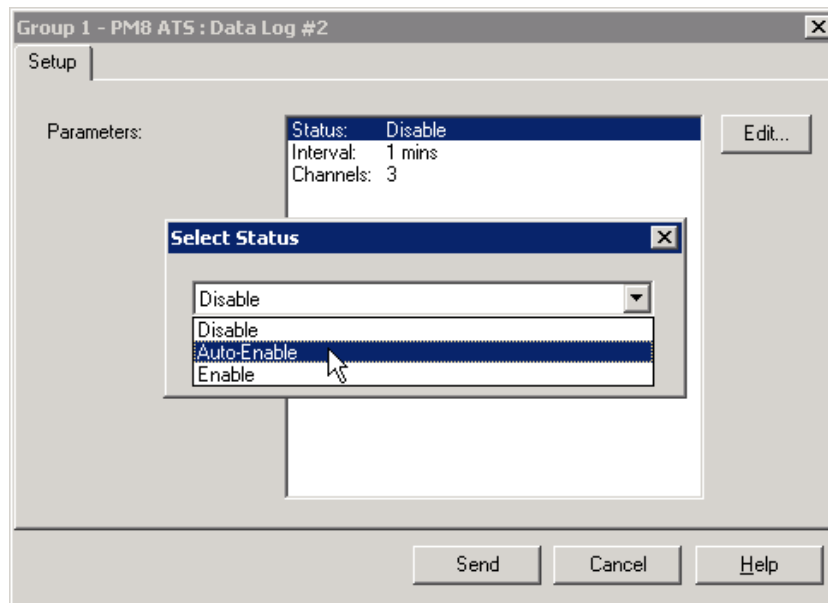

3. Click **Send** to save the changes and send the configuration to the meter.

You can also use Vista to set a Data Log to Auto-Enable. Refer to ["Configure Auto-Enable Data Logs for CM4000 and PM800 series"](#) on page 236 for more information.

## Configure Remote ATS Test Mode for PM800 Series Meter

Switching an ATS to test mode remotely is done by linking a control object in a Vista diagram to a digital output on the PM800 series meter that is connected to the ATS controller.

Refer to *StruxureWare Power Monitoring Expert User Guide* for more instructions on working with Vista diagram control objects.

For details about configuring modules, refer to *ION Reference*.

**NOTE:** The EPSS ATS framework must be deployed to the meter and configured before you can set up the framework for ATS remote switching. For instructions, refer to "[Deploying ATS Frameworks for EPSS](#)" on page 182.

### Configure the Digital Output

Configure the onboard KY output for the meter as follows:

1. In ION Setup for the meter, click I/O Setup. The **Gateway Site** screen appears.
2. In the **Parameters** box, select Digital Out KY and click **Edit**.

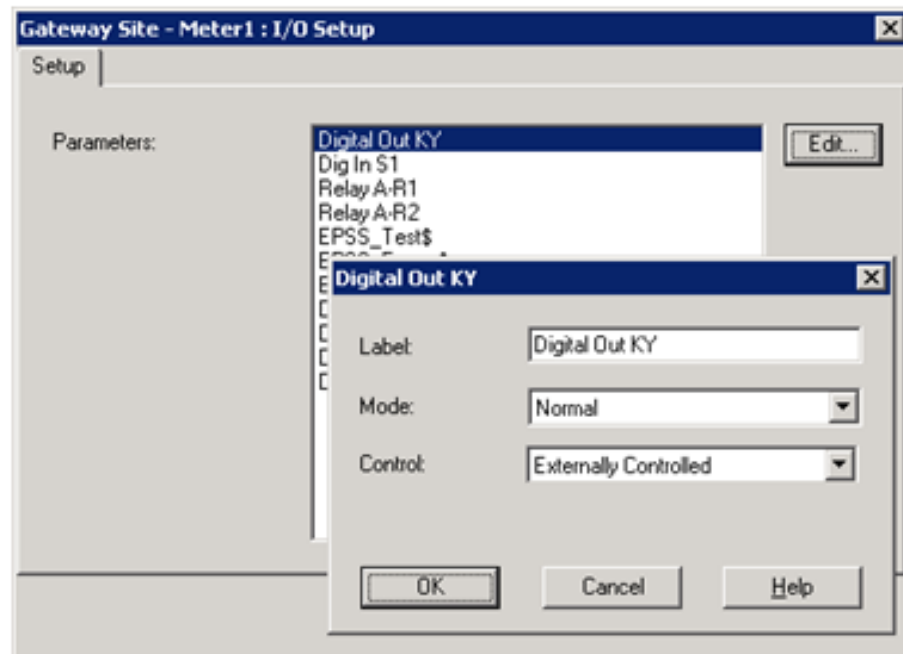

3. In the **Mode** field, select Normal.
 

The mode is dependent on the characteristics of the digital input port on the ATS controller.
4. In the **Control** field, select Externally Controlled.
 

This allows the meter to accept external commands from an application like Vista.
5. Click **OK**. The **Gateway Site** screen appears.
6. Select **Send** to update the meter.

Configure the Vista Diagram for the meter, as described next.

### Configure the Vista diagram

Follow these steps for the PM800 power meter. Make sure Designer is closed before linking any objects in Vista.

In Vista, open a new diagram and complete the setup as follows:

1. Open a new diagram in Vista.
2. Drag a Control object from the Toolbox and link it to KY Energize, as shown next.

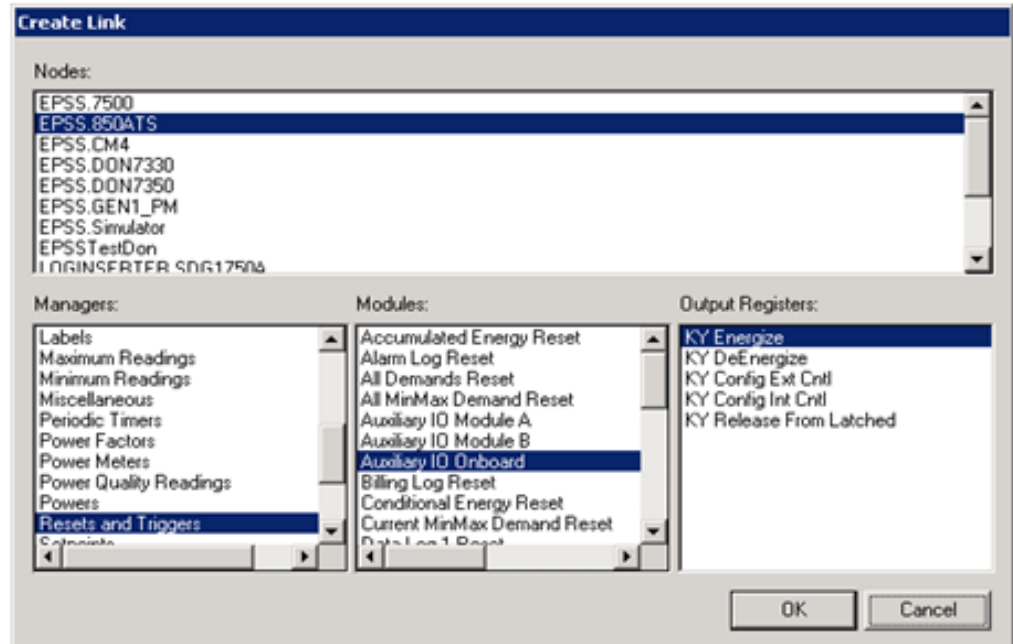

3. Right-click the Control object.
4. On the **Action** tab, set the **Level to Operate** field to Controller, and click **OK**.
5. Drag another Control object from the Toolbox and link it to KY DeEnergize.
6. Right-click the Control object.
7. On the **Action** tab, set the **Level to Operate** field to Controller, and click **OK**.
8. Drag a Status object and link it to the Standard KY Digital Output Status, as shown next.

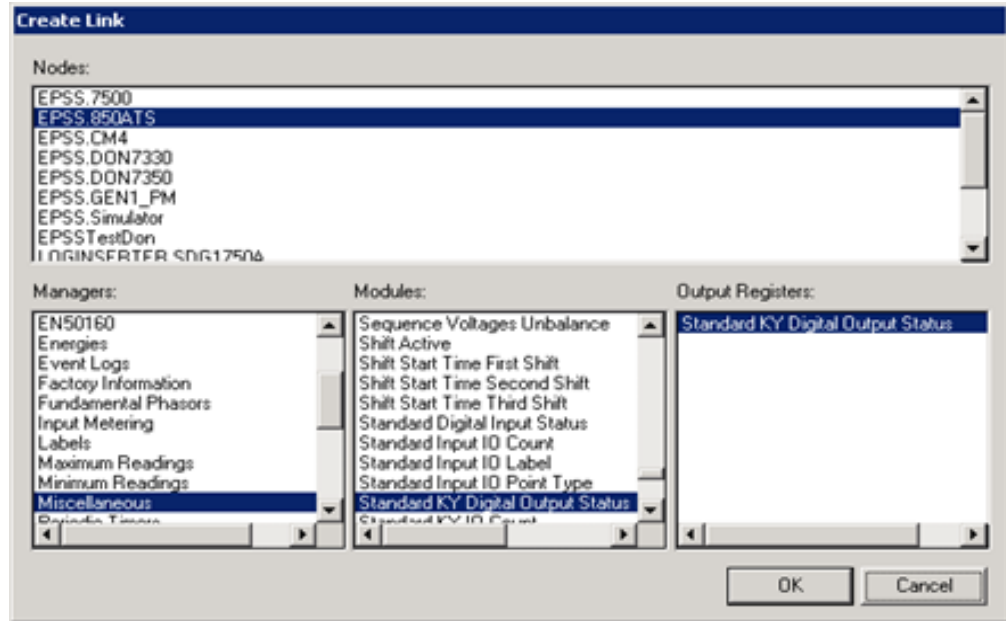

9. Save the diagram. The following image is an example of the Vista diagram.

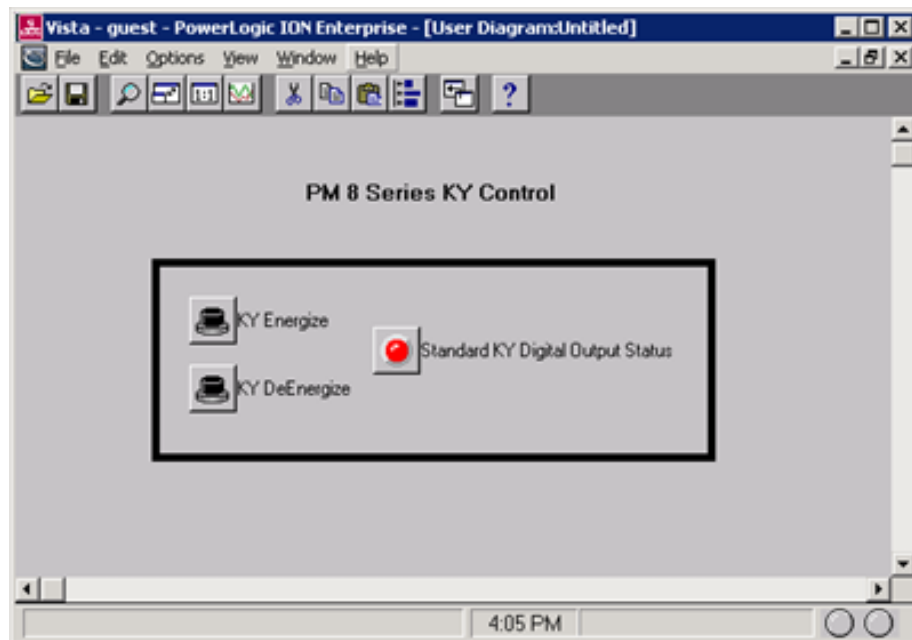

You can now use the diagram to control and view the state of the onboard digital output port.

## Configuring CM3000 and CM4000 Series Meters

This section describes how to configure CM3000 and CM4000 series meters for the system.

To obtain the *CM3000 Installation Manual*, *CM3000 Reference Manual*, and related instructions, go to [www.powerlogic.com](http://www.powerlogic.com) and search for "cm3000 installation."

To obtain instructions for installing and configuring CM4000 series meters, go to [www.powerlogic.com](http://www.powerlogic.com). Select the country, and then **Energy and Power Quality Meters > PowerLogic Energy and Power Quality Meters > CM4000 > Downloads > Tech Publications**.

- Installation Manual
- Reference Manual
- Series 4000T Reference Manual
- I/O Extender and Input/Output Option Card

You can configure the CM4000 series meter for switching the ATS into test mode remotely. See "[Configure Auto-Enable Data Logs for CM4000 and PM800 series](#)" on [page 236](#) for instructions.

## Add CM4000 Series Meters to a Site in ION Setup

Complete the following steps to add CM4000 series meters to a site in ION Setup.

1. In the Network Viewer, right-click the workstation icon and select **Insert Item > Site**. The **New Site** dialog appears.
2. Add a name to identify the site, select **Ethernet**, and click **OK**. The new site appears in the Network Viewer.
3. In the Network Viewer, right-click the new site name and select **Insert Item > Meter**. The **New Device** dialog appears.
4. Complete the following:

**Name** - Enter a name to identify the meter.

**Type** - Select Modbus TCP Device from the dropdown list.

**IP Address** - Enter the IP address for the Modbus TCP.

**Port** - Select 502 from the dropdown list.

**Group** - Select a group name from the list or enter a name to define a new group.

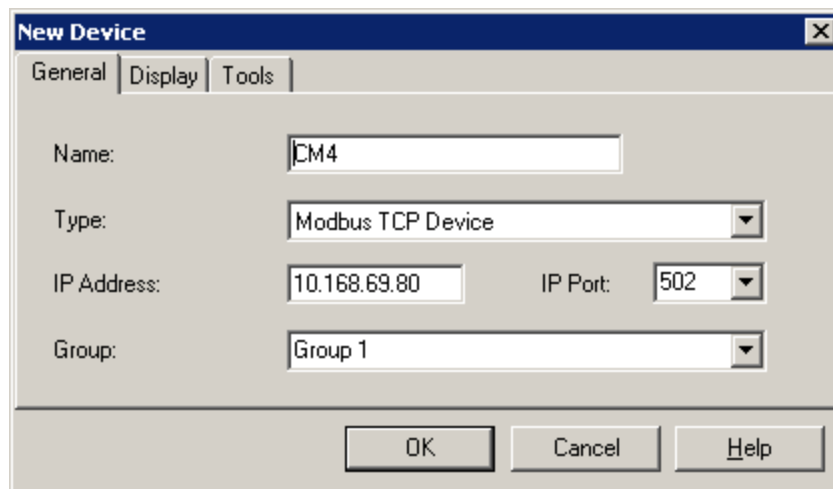

- Click the **Display** tab and select the CM4000 (EPSS) template option.

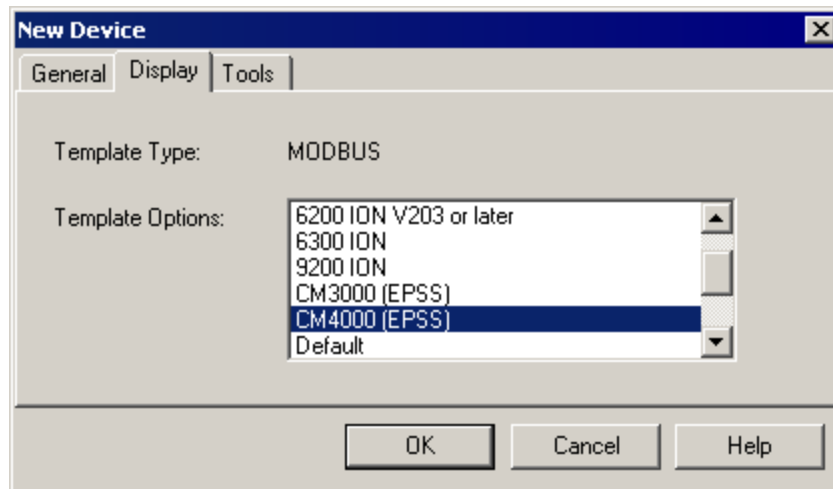

- Click **OK**. The meter is added to the Network Viewer.
- In the Network Viewer, click the meter icon. The setup screens appear in the Content Viewer.

The following image shows the setup screens. Use the **I/O Setup**, **Onboard Alarms/Events**, and **Data Log** setup screens to access the parameters that need to be configured. The remaining topics in this chapter describe the parameter changes that are required.

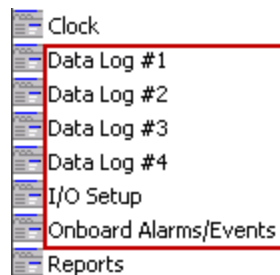

## Configuring Digital and Analog Inputs

This section describes how to configure digital and analog inputs to record data on CM4000 series power meters for the ATs and generators.

### Configure Digital Inputs

In the Content Viewer, double-click **I/O Setup** to access the Digital Inputs for the meter.

- Select the I/O point that you want to configure and click **Edit**.

The following image shows **Dig In B-S1** selected.

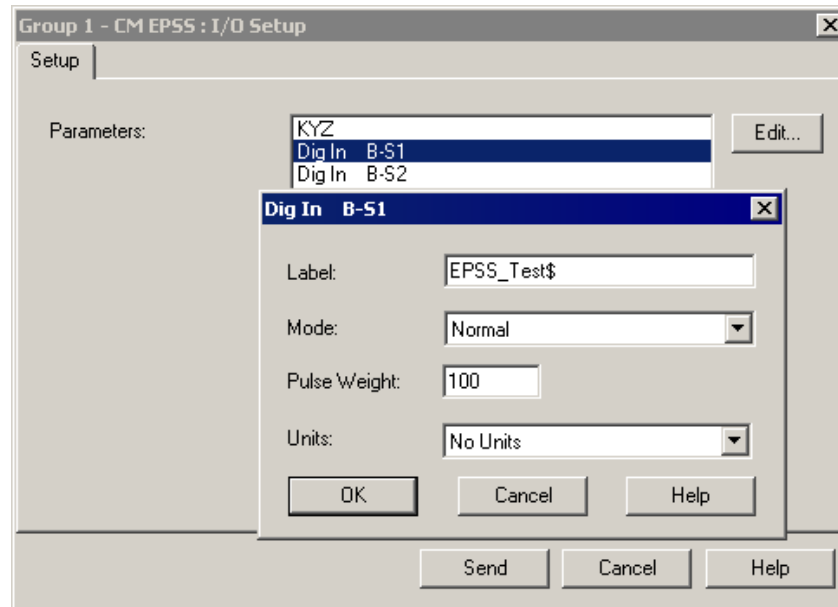

2. Update the **Label** field with the name that ends with the \$ character.  
The \$ character activates the translated device dynamic labeling feature. If the \$ character is not used, the default label is used.
  - For an ATS, examples of labels that conform to the naming convention are EPSS\_Test\$, EPSS\_Emerg\$, EPSS\_Norm\$, and EPSS\_Util\$.
  - For a generator, examples of labels are EPSS\_Start\$, EPSS\_Run\$, and EPSS\_Stop\$.
3. Set **Mode** to Normal, **Pulse Weight** to a non-zero value, for example 100, and leave **Units** set as No Units.
4. Click **OK** to update the parameters and to close the dialog.
5. Repeat the steps above for each I/O point that you want to configure.
6. Click **Send** to save the changes and send the configuration to the meter.

### Configuring Analog Inputs

In the Content Viewer, double-click I/O Setup to access the Analog Inputs for the meter.

1. Select the I/O point that you want to configure and click **Edit**.

The following image shows **Alog In C-AI1** selected.

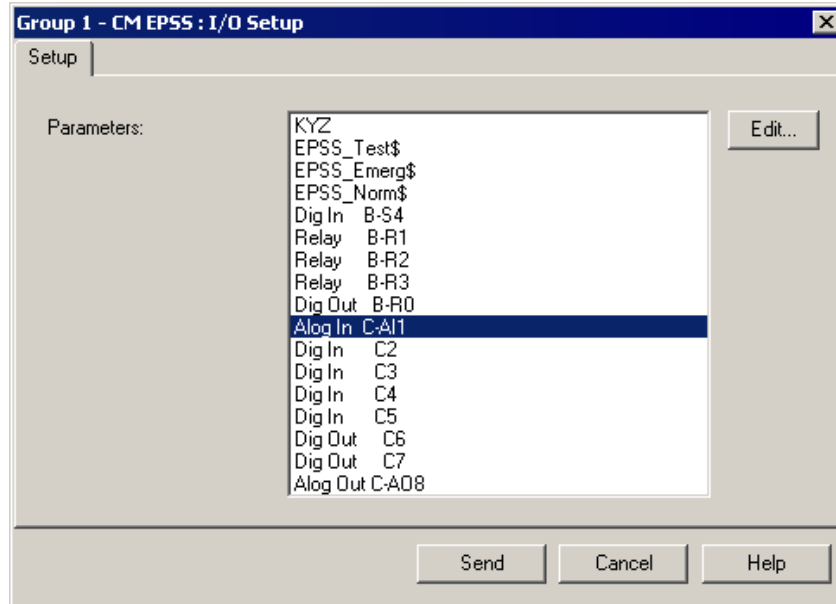

2. Click **Edit** to open the parameter window for the I/O point and update the **Label** field with a name that ends with the \$ character.

For a generator, examples of labels for analog inputs are Exhaust Gas L\$, Exhaust Gas R\$, and Coolant T\$.

The following image shows the label updated to Exhaust Gas L\$.

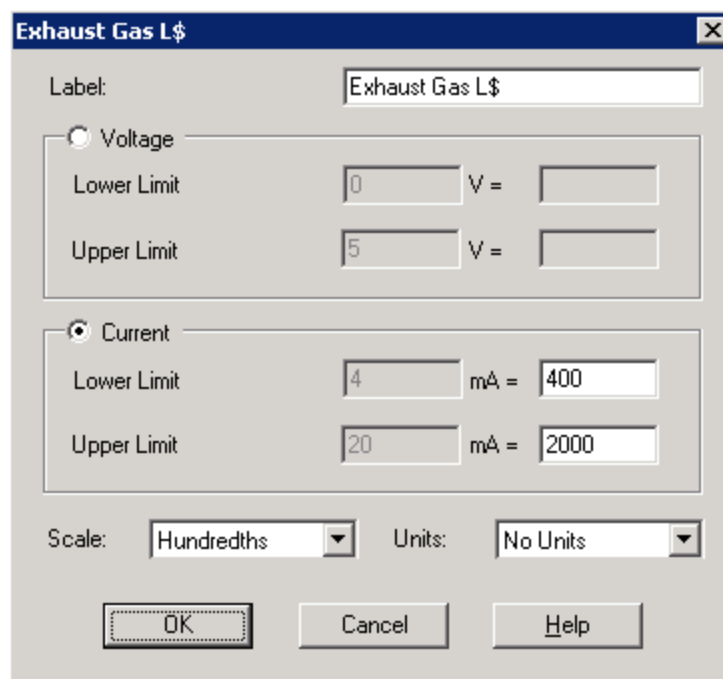

3. Click **OK** to update the parameters and to close the dialog.
4. Repeat the steps above for each I/O point that you want to configure.
5. Click **Send** to save the changes and send the configuration to the meter.

## Configuring Onboard Alarms and Events

For each digital input configured in I/O setup, configure the alarms to record when the digital input on an ATS or a generator changes from OFF to ON, and also from ON to OFF.

### Configure Digital Input Alarms for ATSS

This section assumes that you configured digital inputs **Dig In B-S1** as EPSS\_Test\$, **Dig In B-S2** as EPSS\_Emerg\$, and **Dig In B-S3** as EPSS\_Norm\$.

#### Digital input change from OFF to ON

1. In the Content Viewer, double-click **Onboard Alarms/Events** to open the **Setup** dialog.
2. Select **Digital** and click **Edit** to open the **Digital Alarm Setup** dialog.
3. Select one of the Digital Input/Output points.

The following figure shows the **Dig In B-S1** input selected and its EPSS\_Test\$ label, configured in **I/O Setup**.

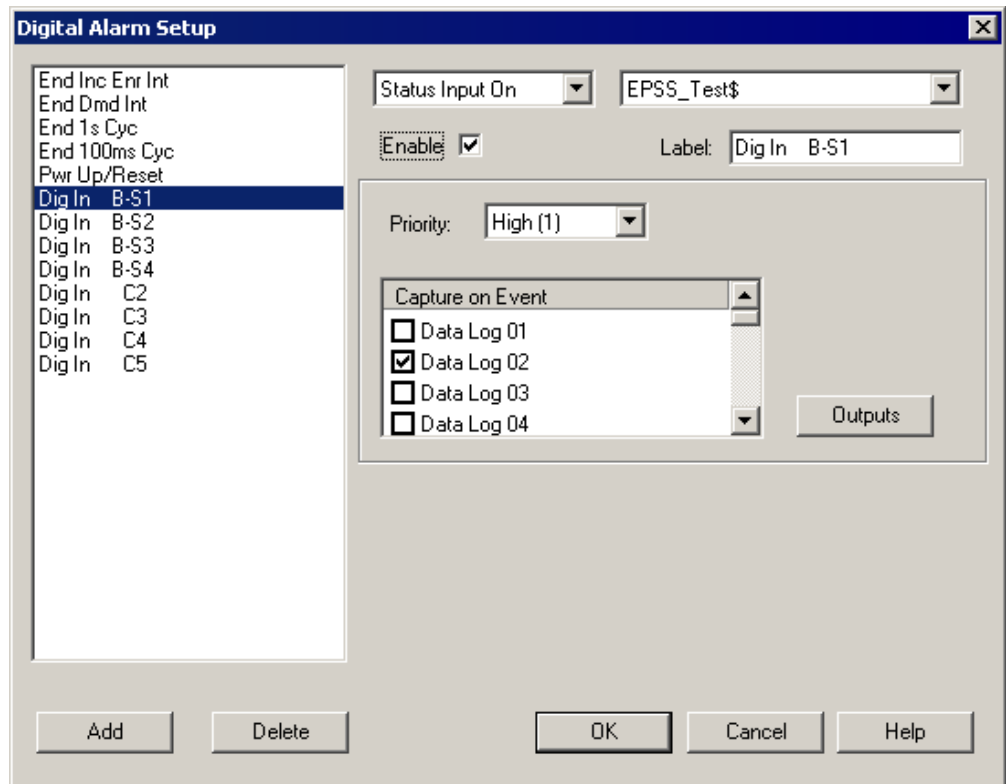

4. Select **Status Input On** from the list to set the alarm when the digital input changes from OFF to ON.
5. Make sure that **Enable** is selected.
6. In the **Label** field, change the digital alarm name from **Dig In B-S1** to **Test ON**.

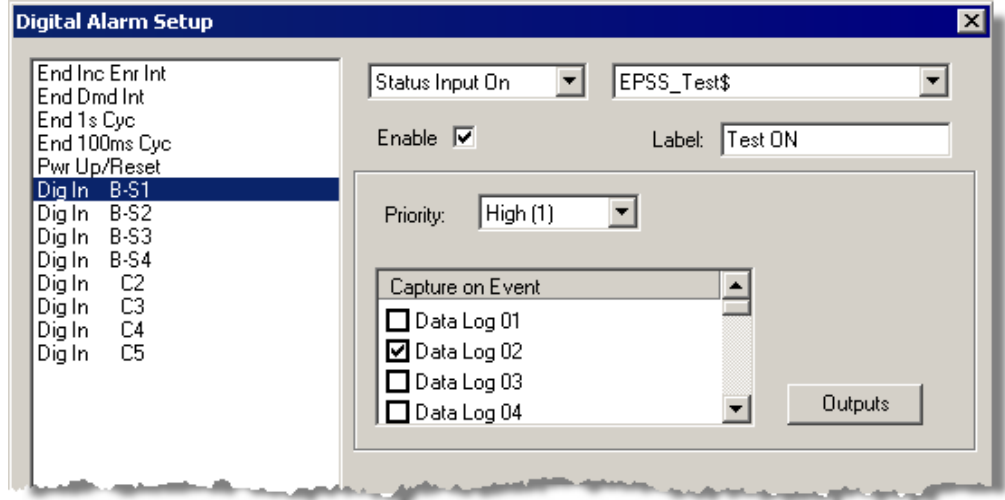

7. Set **Priority** to High(1), and select Data Log 2 as the data log to use.

When the status for EPSS\_Test\$ changes to ON, Data Log 2 records all channels currently configured on it.

**Digital input change from ON to OFF**

1. Click **Add** to add another digital input alarm parameter to the list in the left pane of the **Digital Alarm Setup** dialog.

If all 40 available digital input alarms have been configured already, you need to re-configure an existing alarm for the ON to OFF status change.

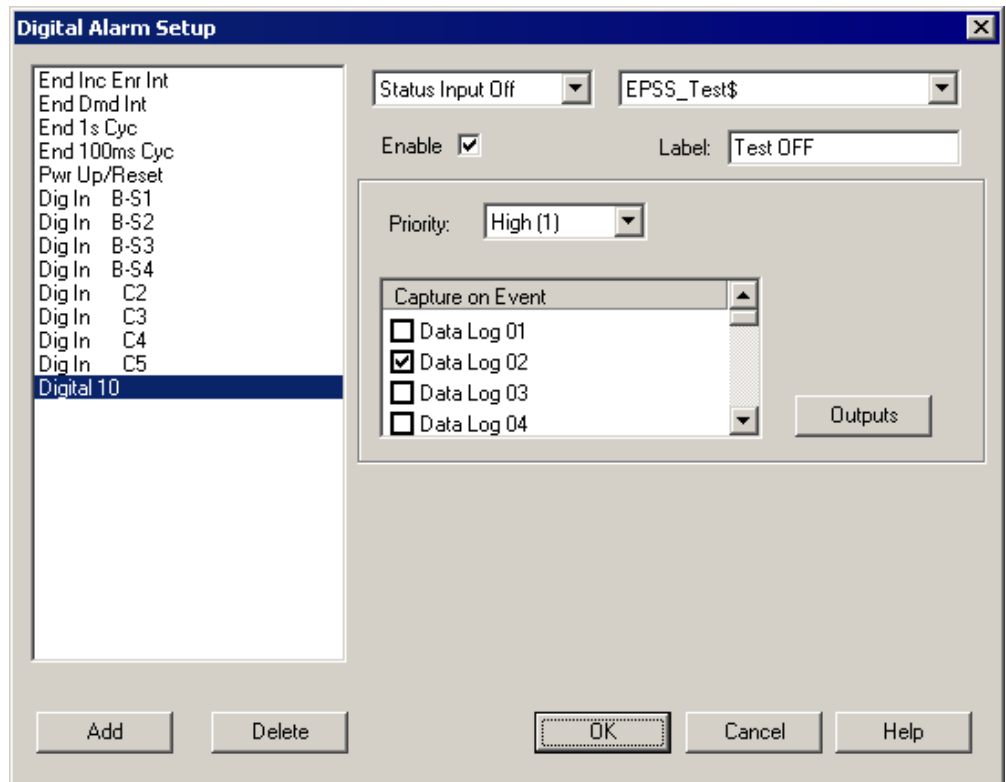

2. Select **Status Input Off** from the list to set the alarm when the digital input changes from ON to OFF.
3. Select EPSS\_Test\$ from the list.
4. Make sure that **Enable** is selected.
5. In the **Label** field, change the digital alarm name to **Test OFF**.
6. Set **Priority** to High(1), and select Data Log 2 as the data log to use.
7. Repeat the steps above to configure alarms for digital input changes from OFF to ON and from ON to OFF for all of the applicable I/O points.

The following table summarizes the configuration of the alarms, assuming that the I/O points are Dig In B-S1, Dig In B-S2, and Dig In B-S3:

Digital Input Label	Maps to	Alarm Status	Alarm Name
EPSS_Test\$	Dig In B-S1	Status Input On	Test ON
EPSS_Test\$	Dig In B-S1	Status Input Off	Test OFF
EPSS_Emerg\$	Dig In B-S2	Status Input On	Emerg ON
EPSS_Emerg\$	Dig In B-S2	Status Input Off	Emerg OFF
EPSS_Norm\$	Dig In B-S3	Status Input On	Normal ON
EPSS_Norm\$	Dig In B-S3	Status Input Off	Normal OFF

8. Click **OK** to close the dialog.
9. Click **Send** to save the changes and send the configuration to the meter.

### Configuring Digital Input Alarms for Generators

This section assumes that you configured digital inputs **Dig In B-S1** as EPSS\_Start\$, **Dig In B-S2** as EPSS\_Run\$, and **Dig In B-S3** as EPSS\_Stop\$.

#### Digital input change from OFF to ON

1. In the Content Viewer, double-click **Onboard Alarms/Events** to open the **Setup** dialog.
2. Select **Digital** and click **Edit** to open the **Digital Alarm Setup** dialog.
3. Select one of the Digital Input/Output points.

The following screenshot shows the **Dig In B-S1** input selected and its EPSS\_Start\$ label, as configured in **I/O Setup**.

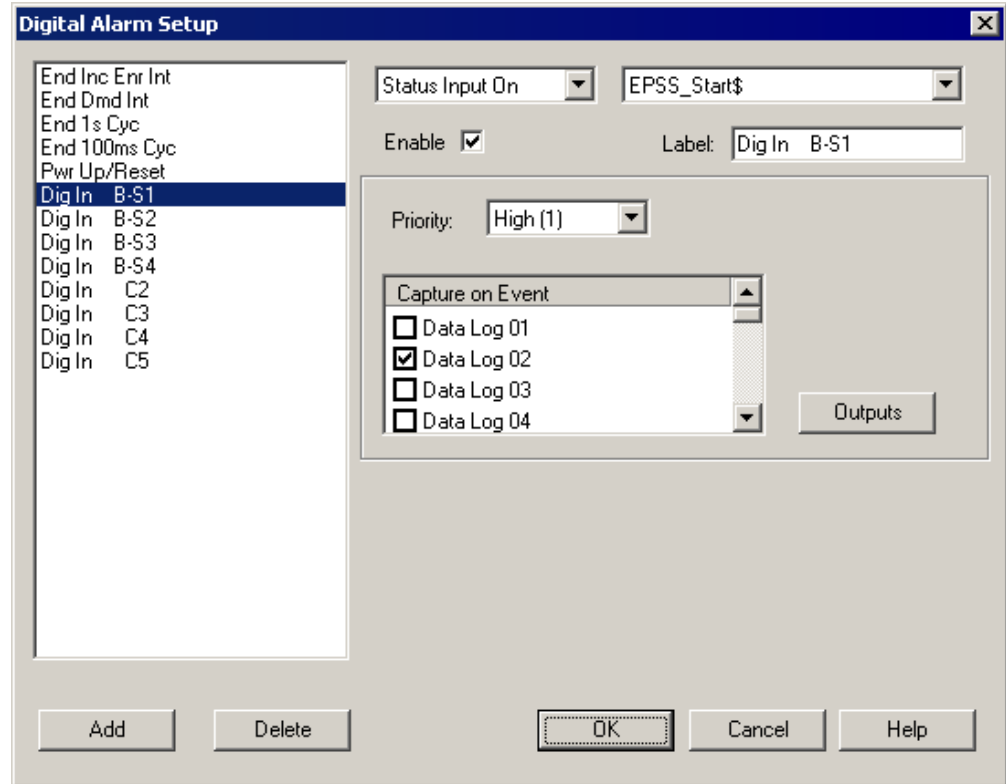

4. Select **Status Input On** from the list to set the alarm when the digital input changes from OFF to ON.
5. Make sure that **Enable** is selected.
6. In the **Label** field, change the digital alarm name from **Dig In B-S1** to **Start ON**.

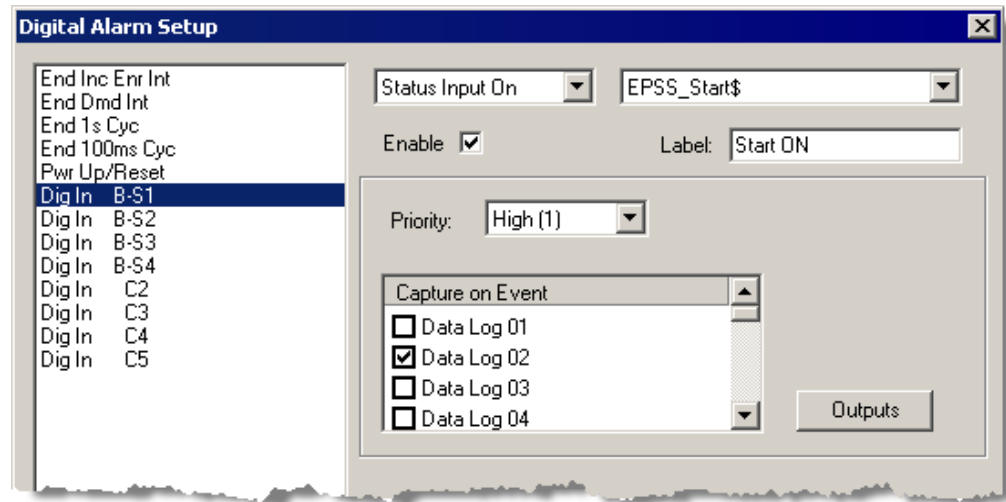

7. Set **Priority** to High(1), and select Data Log 2 as the data log to use.

When the status for EPSS\_Start\$ changes to ON, Data Log 2 records all channels currently configured on it.

**Digital input change from ON to OFF**

1. Click **Add** to add another digital input alarm parameter to the list in the left pane of the **Digital Alarm Setup** dialog.

If all 40 available digital input alarms have been configured already, you need to re-configure an existing alarm for the ON to OFF status change.

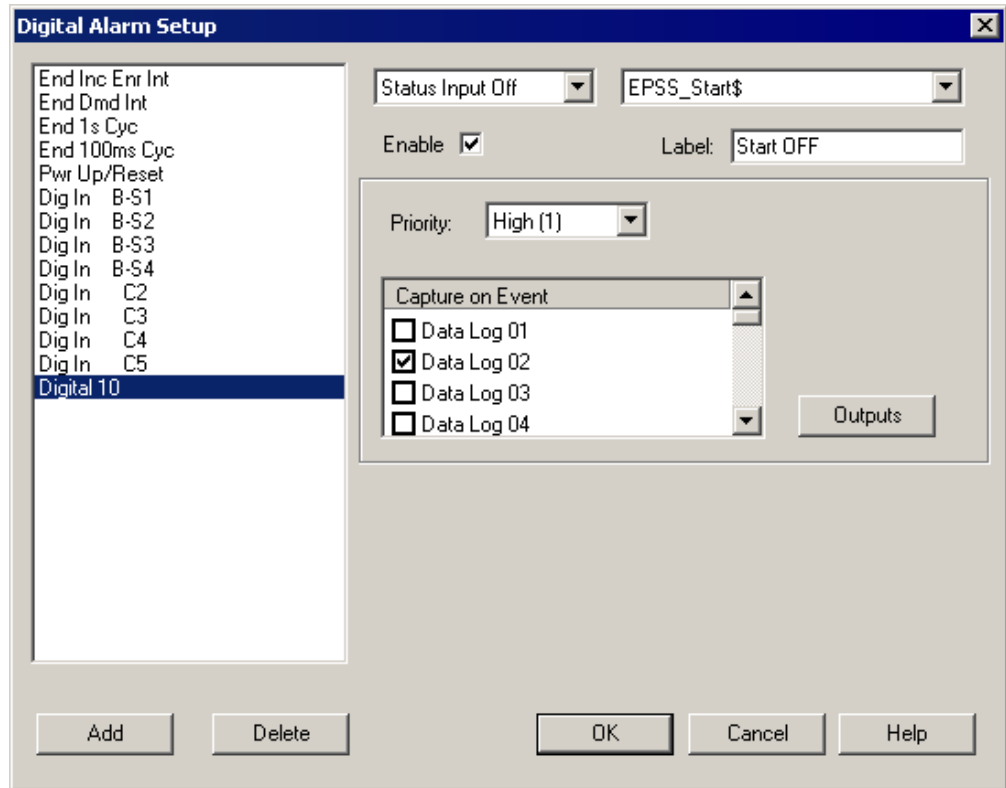

2. Select **Status Input Off** from the list to set the alarm when the digital input changes from ON to OFF.
3. Select **EPSS\_Start\$** from the list.
4. Make sure that **Enable** is selected.
5. In the **Label** field, change the digital alarm name to **Start OFF**.
6. Set **Priority** to High(1), and select Data Log 2 as the data log to use.
7. Repeat the steps above to configure alarms for digital input changes from OFF to ON and from ON to OFF for all of the applicable I/O points.

The following table summarizes the configuration of the alarms, assuming that the I/O points are Dig In B-S1, Dig In B-S2, and Dig In B-S3:

Digital Input Label	Maps to	Alarm Status	Alarm Name
EPSS_Start\$	Dig In B-S1	Status Input On	Start ON
EPSS_Start\$	Dig In B-S1	Status Input Off	Start OFF

Digital Input Label	Maps to	Alarm Status	Alarm Name
EPSS_Run\$	Dig In B-S2	Status Input On	Run ON
EPSS_Run\$	Dig In B-S2	Status Input Off	Run OFF
EPSS_Stop\$	Dig In B-S3	Status Input On	Stop ON
EPSS_Stop\$	Dig In B-S3	Status Input Off	Stop OFF

8. Click **OK** to close the dialog.
9. Click **Send** to save the changes and send the configuration to the meter.

#### Defining a Digital Alarm for a Single Digital Input

If a single digital input is used to record signals indicating when the generator is running, and also when the generator has stopped, you need to define the digital alarm as follows:

1. In the **Digital Alarm Setup** dialog, select the Digital Input/Output point that will be used to record the alarm. For example, if you configured **Dig In B-S1** with a label of `EPSS_Run$`, select this I/O point.
2. Select **Status Input On** from the list to set the alarm when the digital input changes from OFF to ON.
3. Make sure that **Enable** is selected.
4. In the **Label** field, change the digital alarm name from **Dig In B-S1** to **Run ON**.
5. Set **Priority** to High(1), and select Data Log 2 as the data log to use.

#### EPSS\_Run\$: Digital Input Change from ON to OFF

1. Click **Add** to add another digital input alarm parameter to the list in the left pane of the **Digital Alarm Setup** dialog.
2. Select **Status Input Off** from the list to set the alarm when the digital input changes from ON to OFF.
3. Select `EPSS_Run$` from the list.
4. Make sure that **Enable** is selected.
5. In the **Label** field, change the digital alarm name to **Stop ON**.
6. Set **Priority** to High(1), and select Data Log 2 as the data log to use.
7. Click **OK** to close the dialog.
8. Click **Send** to save the changes and send the configuration to the meter.

As a result of this alarm configuration where `EPSS_Run$` represents both the Running and Stopped states for the generator, when **Run ON** is TRUE, the signal is recorded as "1", and when **Stop ON** is TRUE, the signal is recorded as "0".

## Configure the Data Log Parameters

This section describes how to define data log parameters for the digital inputs, analog inputs, and load profile data. The instructions assume that you use Data Logs 2 and 3. However, you can use any Data Log that meets your requirements.

### Define Data Log Parameters for Digital Inputs

Complete the following steps to define the data log parameters for the digital inputs.

1. In the Content Viewer, double-click **Data Log #2** to open the **Setup** dialog for the data log parameters.
2. Set **Status** to Enable and **Interval** to Only On Event.
3. Select **Channels**, click **Edit**. The Parameter Selection screen appears.

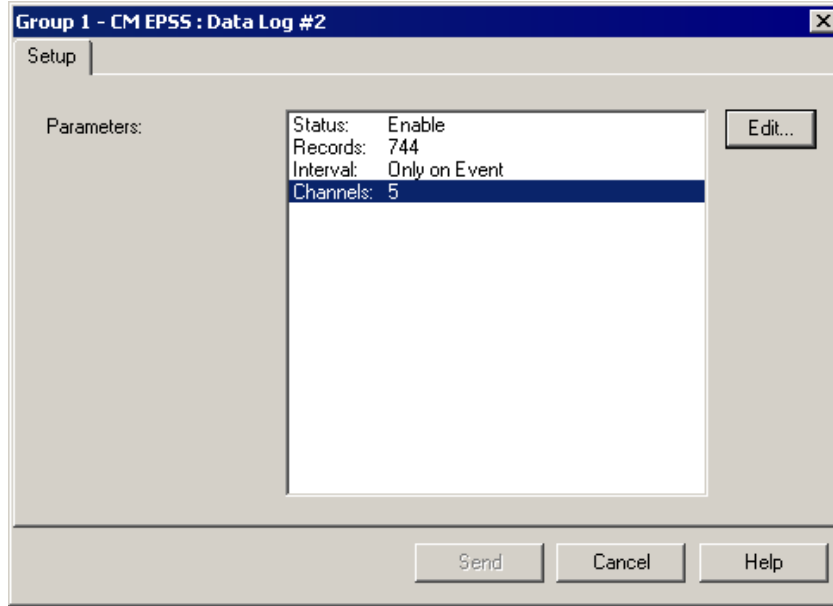

4. In the **Available** box, navigate to **Inputs/Outputs** and select a custom label, such as EPSS\_Emerg\$.
5. Under **Digital Input**, select the **IO Point xx Digital State**, where xx is the number of the I/O point present on the meter. Click **>>** to move the parameter to the **Selected** box.

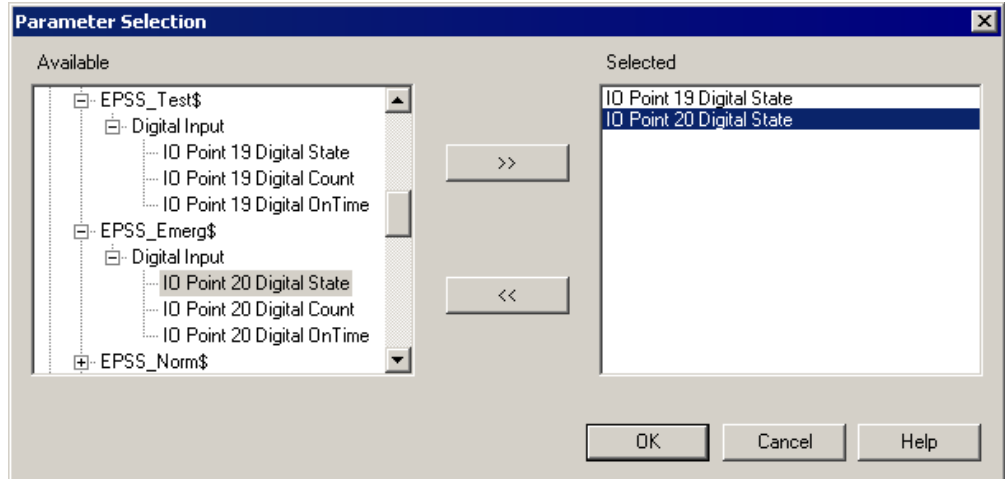

6. Repeat steps 4 - 5 for all I/O points available for the ATS or generator.
7. In the **Available** box, expand **Miscellaneous** and select **Present MilliSeconds**. Click **>>** to move it to the **Selected** box.

Add all I/O points for a given ATS or generator to the data log to help ensure that all of the states are recorded in the data log when any state changes.

8. Click **OK** to close the screen.
9. Click **Send** to save the changes and send the configuration to the meter.

#### **Define Data Log Parameters for Analog Inputs and Load Profile Data**

Configure the system to log the analog inputs and load profile data automatically when the generator state changes to Running. When the generator state is Running, the alarm status for digital input EPSS\_Run\$ is ON.

Using ION Setup, the process to configure automatic logging is:

1. Associate Data Log 3 with the digital input alarm **Run ON** that you previously defined for EPSS\_Run\$.
2. Select the parameters for the Analog Input data to be logged in Data Log 3.
3. Select the parameters for the Load Profile data to be logged in Data Log 3.
4. Set the status of Data Log 3 to Auto-Enable.

These steps assume that you use Data Log 3.

#### **Associate Data Log 3 with the Digital Input Alarm Run ON**

1. In the Content Viewer, double-click **Onboard Alarms/Events** to open the **Setup** dialog.
2. Select **Digital** and click **Edit** to open the **Digital Alarm Setup** dialog.
3. Select the digital input alarm **Run ON** that was defined for I/O point EPSS\_Run\$. You previously selected Data Log 2 when you configured this digital input alarm for the generator.
4. In the **Capture on Event** list, select Data Log 3. Now both Data Logs 2 and 3 are selected.

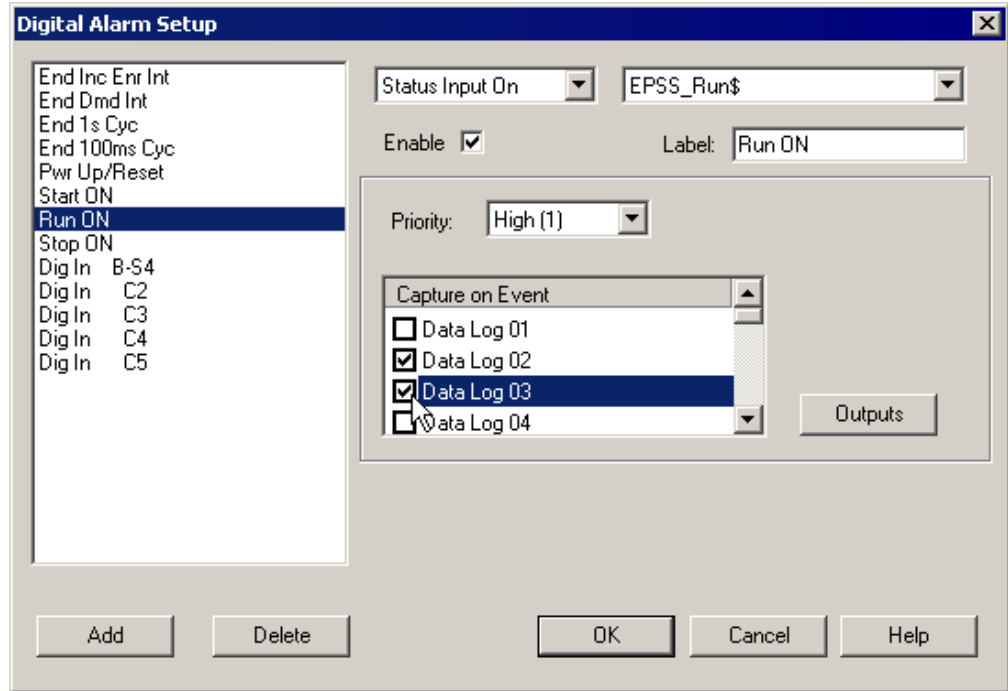

5. Click **OK** to close the screen.
6. Click **Send** to save the changes and send the configuration to the meter.

**Select Parameters for Analog Input Data to be logged in Data Log 3**

1. In the Content Viewer, double-click **Data Log #3** to open the **Setup** dialog.
2. Select **Interval** and click **Edit** to open the **Enter Logging Interval** dialog.
3. In the **Mode** list, select **Continuous**. Set **Interval** to 1 minute, and click **OK** to close the dialog.

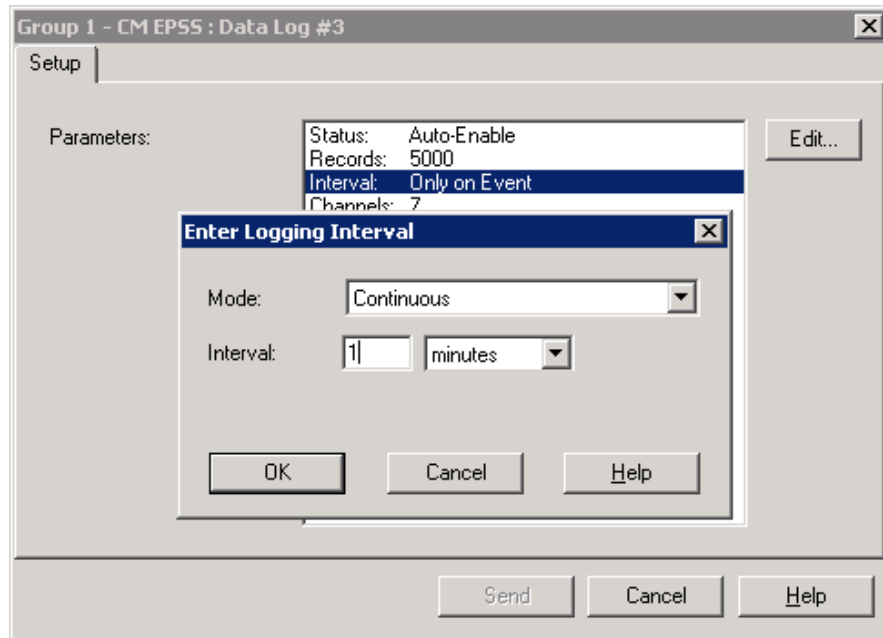

4. Select **Channels**, click **Edit**. The Parameter Selection screen appears.
5. In the **Available** box, navigate to **Inputs/Outputs** and select a custom label, such as Exhaust Gas L\$.
6. Under **Analog Input**, select the **IO Point xx Analog Input Value**, where xx is the number of the I/O point present on the meter. Click **>>** to move the parameter to the **Selected** box.

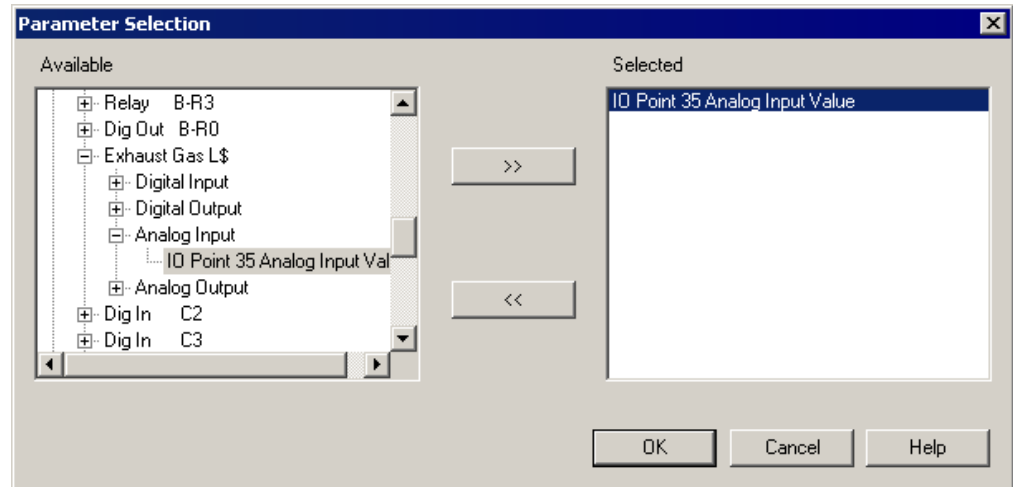

7. Repeat steps 4 - 5 for each analog input available for the generator.
8. Click **OK** to close the dialog.
9. Click **Send** to save the changes and send the configuration to the meter.

### Select Parameters for Load Profile Data to be logged in Data Log 3

1. In the **Setup** dialog for Data Log 3, select **Channels** and click **Edit**. The **Parameter Selection** dialog appears.
2. Expand each of the following categories. Within each category, select the parameters indicated. For each parameter click **>>** to move it to the **Selected** column:
  - a. In **Currents**, select Current A, Current B, Current C, Current N, and Current Avg.
  - b. In **Minimum Readings**, select Min Apparent Power Total, Min Real Power Total.
  - c. In **Miscellaneous**, select Frequency.
  - d. In **Powers**, select Real Power Total and Apparent Power Total.
  - e. In **Voltages**, select Voltage A-B, Voltage B-C, Voltage C-A, Voltage L-L Avg, Voltage A-N, Voltage B-N, Voltage C-N, and Voltage L-N Avg.

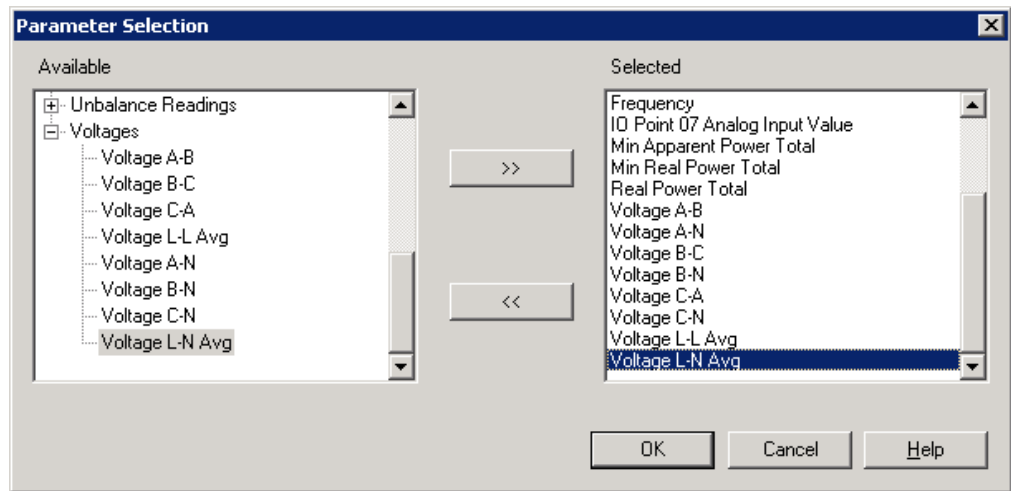

3. Click **OK** to close the dialog.
4. Click **Send** to save the changes and send the configuration to the meter.

### Set the Status of Data Log 3 to Auto-Enable

Auto-Enable is a special mode that allows logging to be triggered when an alarm occurs. Data is recorded in the data log at a defined interval if the logging mode is set to **Continuous**. Logging stops when the alarm ends.

1. In the **Setup** dialog for Data Log 3, select **Status** and click **Edit**. The **Select Status** dialog appears.
2. Select **Auto-Enable** in the dropdown list and click **OK**.

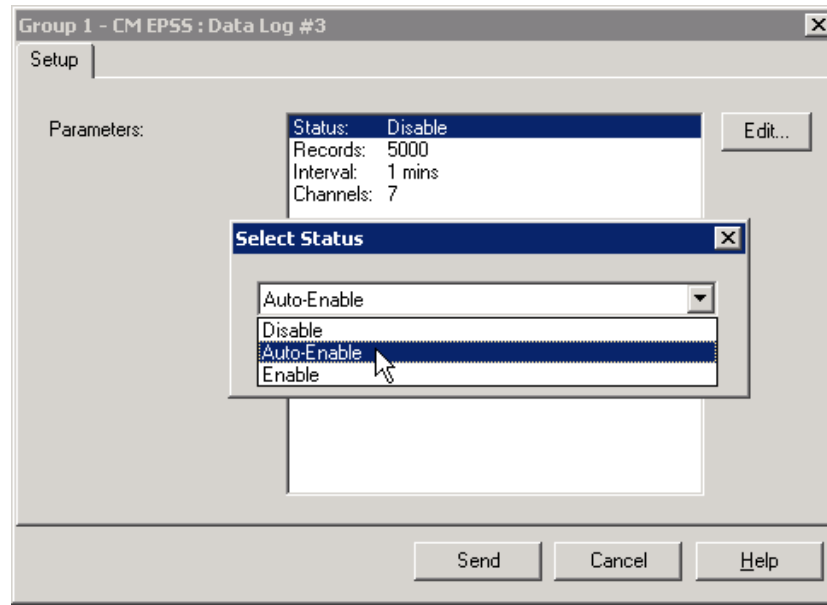

3. Click **Send** to save the changes and send the configuration to the meter.

You can also use Vista to set a Data Log to Auto-Enable. See "[Configure Auto-Enable Data Logs for CM4000 and PM800 series](#)" on page 236.

## Configure Auto-Enable Data Logs for CM4000 and PM800 series

This section explains how to use Vista to configure the data logs for PM800 Series Meters and the CM4000 Series Meters for auto-enable.

Auto-Enable is a special mode that allows logging to be triggered when an alarm occurs. Data is recorded in the data log at a defined interval if the logging mode is set to **Continuous**. Logging stops when the alarm ends. The following instructions assume that you associated Data Log 2 with the digital input alarm **Run ON** for the purpose of logging the analog inputs and load profile data.

For information about using ION Setup to set a Data Log to Auto-Enable, see:

- For PM800 series meters, see "[Set the Status of Data Log 2 to Auto-Enable](#)" on page 217.
- For CM4000 series meters, see "[Set the Status of Data Log 3 to Auto-Enable](#)" on page 235.

### Use Vista to Set a Data Log to Auto-Enable

Complete the following steps to use Vista to set the status of Data Log 2 to Auto-Enable.

1. Open Vista and select **File > New** to open an empty workspace.
2. Ensure that the Toolbox is open. If not, select **Options > Show Toolbox**.
3. In the Toolbox, select a **Control Object** and drag it to the workspace.
4. Right-click the control object. The **Control Object Configuration** screen appears.

- Click the **Link** tab. In the **Link** area, select **Custom**, and then click **Edit Link**. The **Create Link** screen appears.
- In the **Nodes** list, double-click the meter name. The associated module directories appear in the **Managers** list.

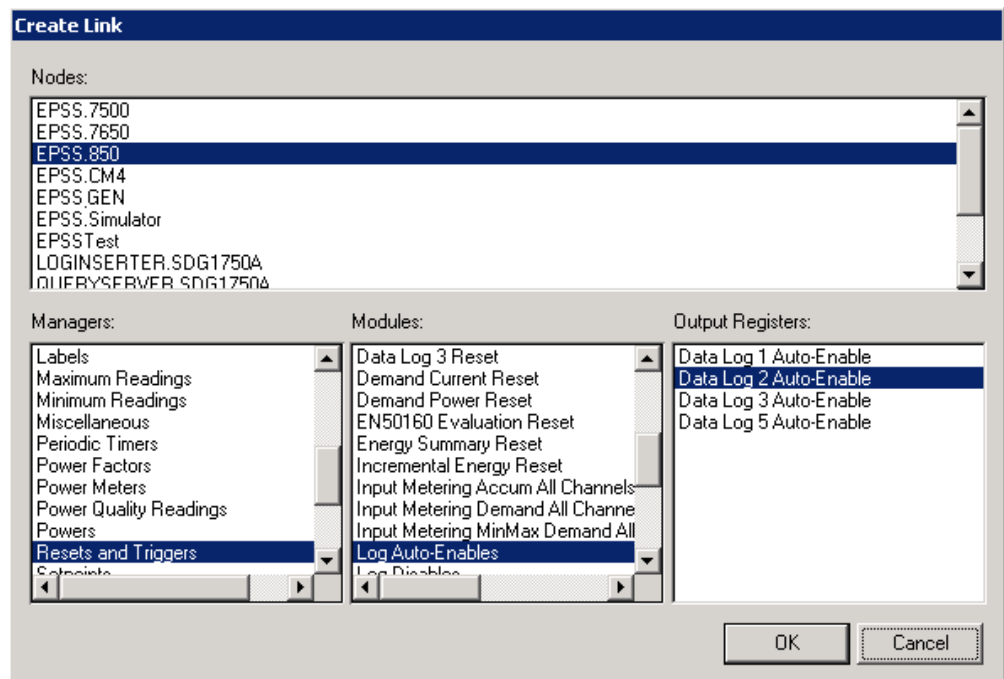

- In the **Managers** list, double-click **Resets and Triggers**.
- In the **Modules** list, double-click **Log Auto-Enables**.
- In the **Output Registers** list, select **Data Log 2 Auto-Enable**.
- Click **OK** to save the selection and to close the screen.
- Double-click the control object in the workspace to set Data Log 2 on the meter to Auto-Enable.



## Verify that Data Log 2 has been set to Auto-Enable

You can verify that Data Log 2 has been set to Auto-Enable by adding a numeric object to the workspace and linking it to a setup register for the Data Log.

- In Vista, ensure that the Toolbox is open. If not, select **Options > Show Toolbox**.
- In the Toolbox, select a **Numeric Object** and drag it to the workspace.
- Right-click the numeric object. The **Numeric Object Configuration** screen appears.

4. Click the **Link** tab. In the **Link** area, select **Custom** and press the **Ctrl** key while clicking **Edit Link**. The **Create Link** screen for Setup Registers.
5. In the **Nodes** list, double-click the meter name. The associated module directories appears in the **Managers** list.

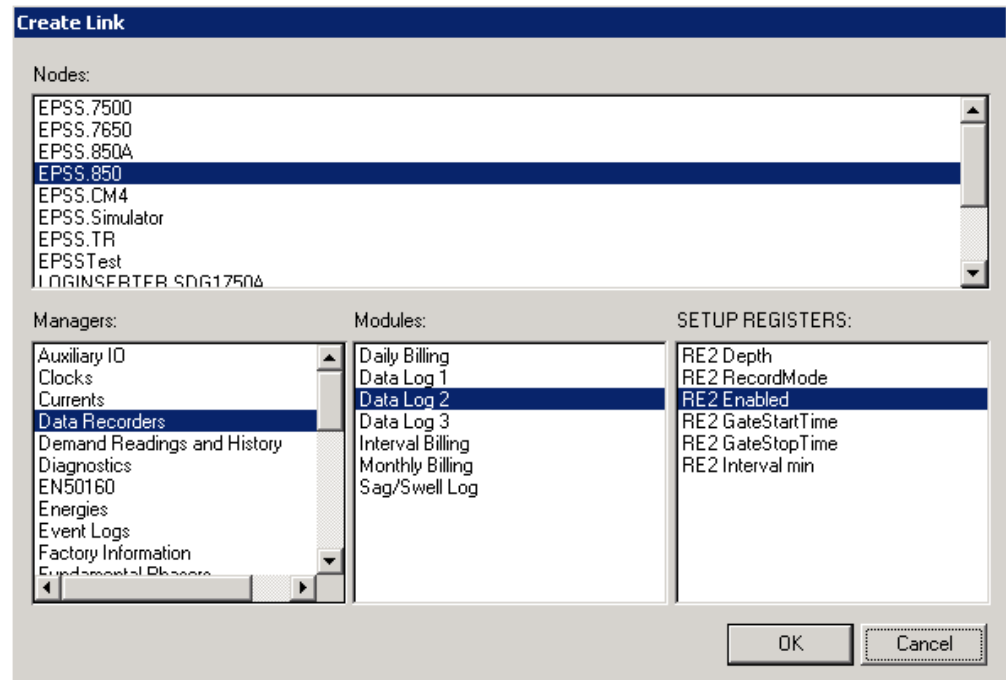

6. In the **Managers** list, double-click **Data Recorders**.
7. In the **Modules** list, double-click **Data Log 2**.
8. In the **Setup Registers** list, select **RE2 Enabled**.
9. Click **OK** to save the selection and to close the screen.

When the numeric object displays "Auto," you have confirmation that Data Log 2 has been set successfully to Auto-Enable by the control object.



## Configuring Momentum PLC

This chapter describes how to configure Momentum PLC for the system.

For information about installing and configuring Momentum PLC, see the PLC's documentation at [www.powerlogic.com](http://www.powerlogic.com).

<b>⚠ WARNING</b>
<b>UNINTENDED OPERATION</b>
<ul style="list-style-type: none"><li>• Do not use the Momentum PLC with either Power Monitoring Expert or ION Setup for critical control or protection applications where human or equipment safety relies on the operation of the control circuit.</li><li>• Refer to your PLC's technical documentation for more information on its operation.</li></ul>
<b>Failure to follow these instructions can result in death, serious injury, or equipment damage.</b>

### Add a Momentum PLC to a Site

Use ION Setup to add each Momentum PLC to a site.

1. In the Network Viewer, right-click the workstation icon and select **Insert Item > Site**. The **New Site** screen appears.
2. Complete the fields to define the new site:
  - **Name** - Add a name to identify the site.
  - **Comm Link** - Select **Ethernet**.
  - **Ethernet Options** - Select **Gateway**.
  - **IP Address** - Enter the IP Address for the device.
  - **Port** - Select 502.

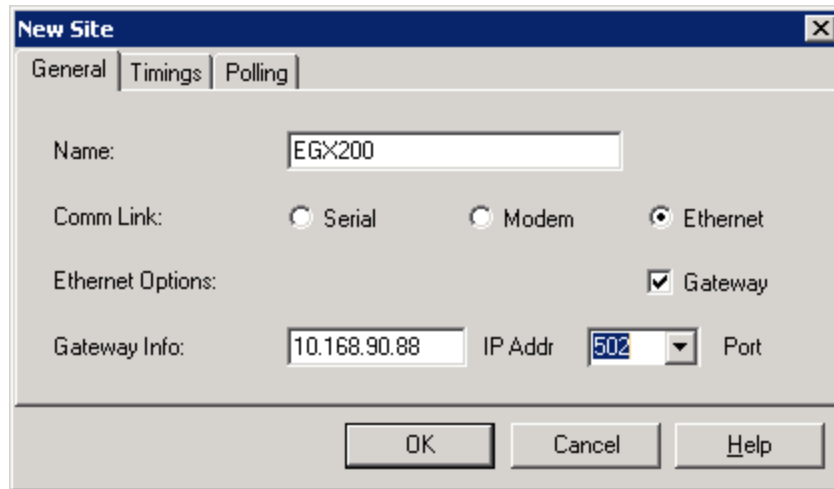

3. Click **OK** to add the site. The new site appears in the Network Viewer.

4. In the Network Viewer right-click the site name and select **Insert Item > Meter**. The **New Device** screen appears.
5. Complete the fields to define the PLC:
  - **Name** - Enter a name to identify the device.
  - **Type** - Select Modbus RTU Device from the dropdown list.
  - **Unit ID** - Enter the unit ID for the device.
  - **Group** - Select a group name from the list or enter a name to define a new group.

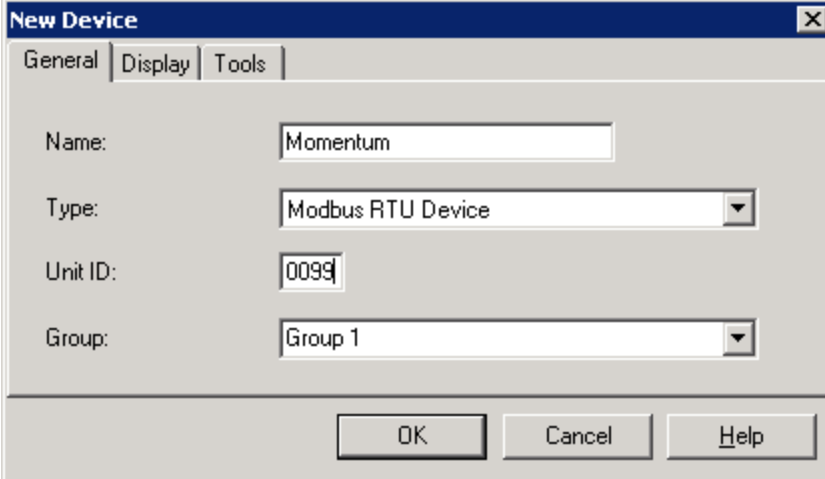

The screenshot shows the 'New Device' dialog box with the 'General' tab selected. The fields are filled as follows:

Name:	Momentum
Type:	Modbus RTU Device
Unit ID:	0099
Group:	Group 1

Buttons at the bottom: OK, Cancel, Help.

6. Click the **Display** tab and select the **Momentum PLC D16 (EPSS)** template option.

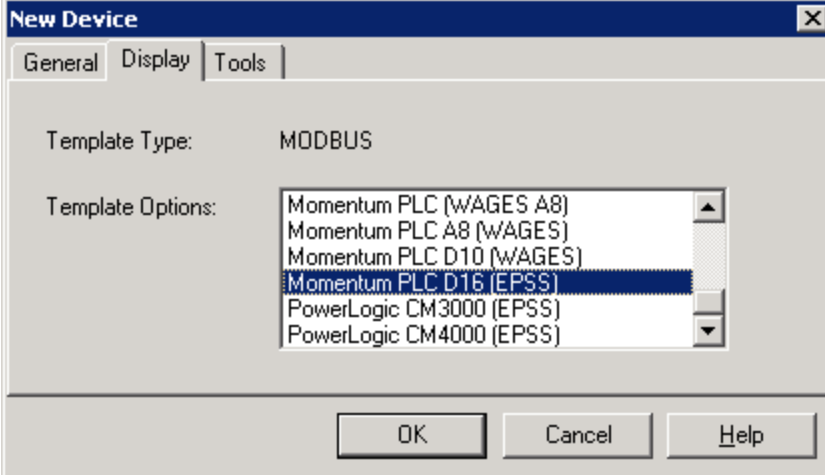

The screenshot shows the 'New Device' dialog box with the 'Display' tab selected. The fields are filled as follows:

Template Type:	MODBUS
Template Options:	Momentum PLC (WAGES A8) Momentum PLC A8 (WAGES) Momentum PLC D10 (WAGES) <b>Momentum PLC D16 (EPSS)</b> PowerLogic CM3000 (EPSS) PowerLogic CM4000 (EPSS)

Buttons at the bottom: OK, Cancel, Help.

7. Click **OK** to add the PLC to the site.

After a PLC has been added, click its icon in the Network Viewer to display the setup screens in the Content Viewer. The following image shows a partial list of the setup screens.

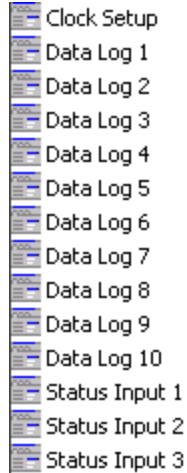

The remaining topics in this chapter describe how to configure the parameters for the **Clock Setup**, **Data Log** and **Status Input** setup screens.

## Setting the Clock

Follow these steps to set or adjust the date and time for the PLC's clock.

1. In the Content Viewer, double-click **Clock Setup**. The **Clock Setup** screen appears.  
The first time you access this screen, the label under the **Select** column is "Device time" and the **Date/Time** column shows the current time on the PLC.
2. Select the Date/Time entry and click **Edit**. The **Date/Time Setup** screen appears.

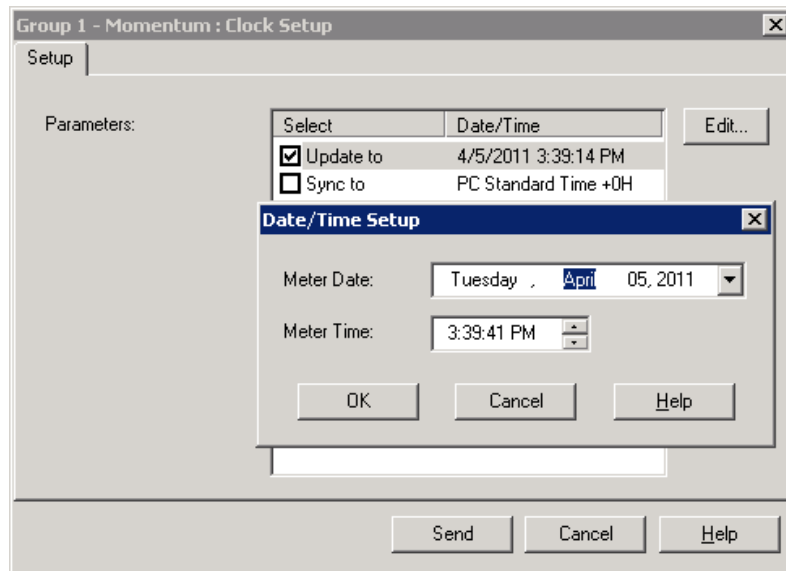

3. Set the desired date and time in the **Meter Date** and **Meter Time** fields.
4. Click **OK**. The **Date/Time Setup** screen closes.

The "Device time" label changes to "Update to" and is automatically selected. The check mark indicates that the new date and time value will be sent to the PLC when you click **Send**.

If you clear the check box, the date and time entry reverts to the time currently configured on the PLC.

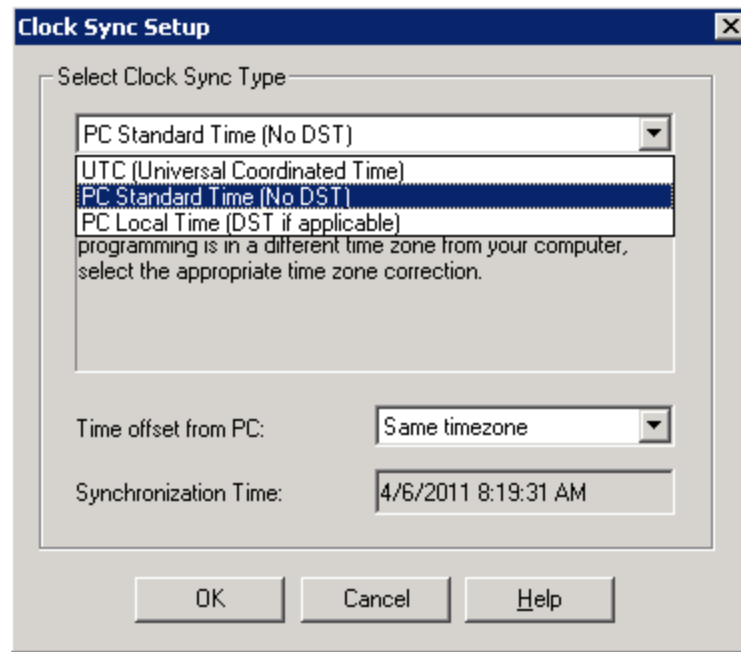

## Configuring Status Inputs

Follow these steps to configure the status inputs on Momentum PLCs so that data about the states of the ATs and generators is recorded.

1. In the Content Viewer, double-click **Status Input 1**. The **Status Input 1** screen appears.

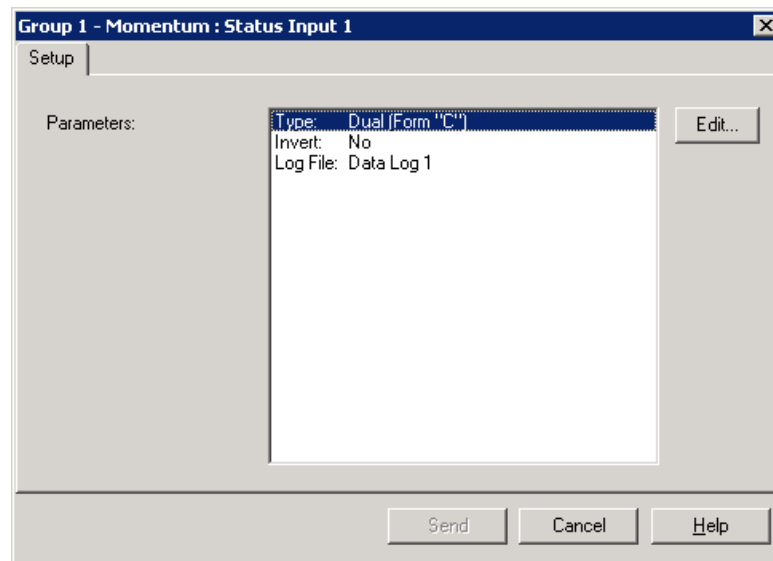

2. In the **Parameters** box, select **Type** and click **Edit**. The **Select Type** screen appears.

3. In the **Type** box, select **Dual(Form "C")** and click **OK**. This parameter generates an event for both the leading and trailing edges of the signal.
4. Select **Invert** and click **Edit**. The **Select Invert** screen appears.
5. In the **Invert** box, select **No** and click **OK**.
6. Select **Log File** and click **Edit**. The **Select Log File** screen appears.
7. In the **Log File** box, select the data log for the status input and click **OK**.
8. Click **Send** to save the changes and send the configuration to the PLC.

Keep track of these status inputs for correct mapping to the ATS and generator states through the Generator Test Module EPSS. Status inputs for ATSs need to be set to Test, Emergency, and Normal states. For generators, they need to be set to Run and Stop states.

For example, the following table shows the relationship of Status Inputs on the PLC to the settings that are applied through the Generator Test Module EPSS.

Momentum PLC		EPSS Generator Test Module	
Slot Position	Status Inputs	EPSS Device	State
1	Status Input 1	ATS1	Test
2	Status Input 2		Normal
3	Status Input 3		Emergency
4	Status Input 4	GEN1	Run
5	Status Input 5		Stop
...	...	...	...

## Defining Data Log Parameters for Status Inputs

Complete these steps to define the data log parameters for the Status Inputs.

1. In the Content Viewer, double-click **Data Log x**, where **x** is the number for the datalog. The **Setup** screen appears.
2. Select the following parameters and click **Edit** to configure them in the Parameter Selection screen:
  - Set **Status** to Enable.
  - Set **Records** to a non-zero value.
  - Set **Interval** to Only On Event.

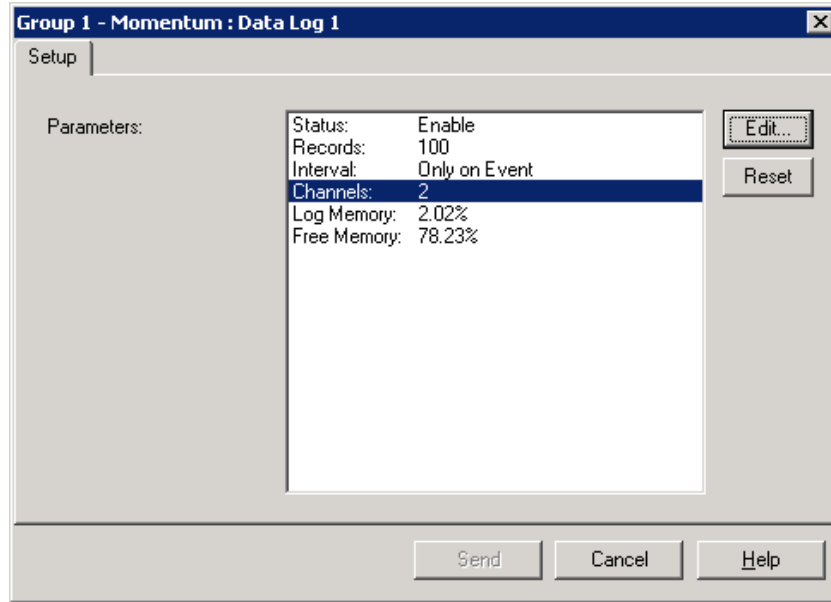

3. Select **Channels**, click **Edit**.
4. In the **Available** box, navigate to **Status Inputs**.

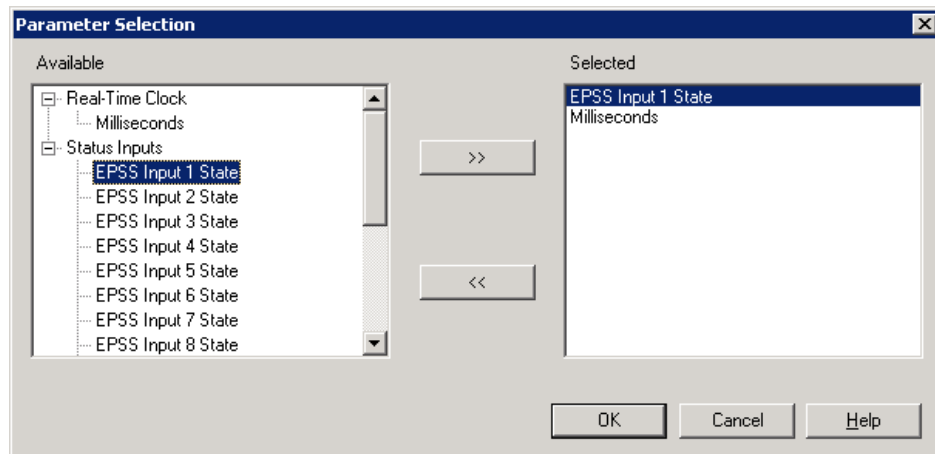

5. Expand **Status Inputs**, select an EPSS input state, such as **EPSS Input 1 State**, click **>>** to move it to the **Selected** column.
6. Repeat steps 4 and 5 for all status inputs available for the ATs or generators.
7. Expand **Real-Time Clock**, select **MilliSeconds** and click **>>** to move it to the **Selected** column.
8. Click **OK**.
9. Repeat steps 1 through 8 for all of the Data Logs that you want to configure.
10. Click **Send** to save the changes and send the configuration to the PLC.

## Configuring Digital Outputs

The standard Momentum PLC device driver does not support the configuration of digital outputs. However, you can use the Modbus Device Importer (MDI) to define and configure digital outputs.

The following information assumes that you already configured an Ethernet Gateway site in Management Console and that you added a device to the site. For more information, see *Setting Up Devices for Ethernet Gateway Communications* in the online help for Management Console or in the *StruxureWare Power Monitoring Expert User Guide*.

### Configure Digital Outputs in MDI

Complete these steps Modbus Device Importer (MDI) to define and configure digital outputs on the PLC.

Before proceeding, make a backup copy of the Momentum PLC map and tree files Momentum\_PLC\_D16\_EPSS.xml and Momentum\_PLC\_D16\_EPSS.ion, respectively. These files are located in the ..\Schneider Electric\system\translators\ folder.

1. In Management Console, select **Tools > System > Modbus Device Importer**. The MDI main console appears.
2. Open the existing Momentum PLC driver configuration:
  - a. Select **File > Open** and browse to C:\Program Files (x86)\Schneider Electric\Power Monitoring Expert for Healthcare\system\translators.
  - b. Select Momentum\_PLC\_D16\_EPSS.ion.
  - c. Click **Open**. The register details appear in MDI.
3. Under **ION Map Information**, right-click Momentum\_PLC\_D16\_EPSS and select **New Manager**. The **Add New Manager** screen appears.

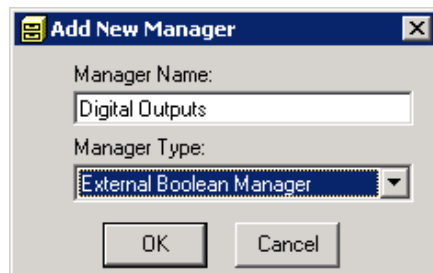

4. In the **Manager Name** box, enter **Digital Outputs**. In the **Manager Type** box, select **External Boolean Manager**. Click **OK**.
5. Under **ION Map Information**, right-click **Digital Outputs** and select **New Module**. The **Add New Module** screen appears.

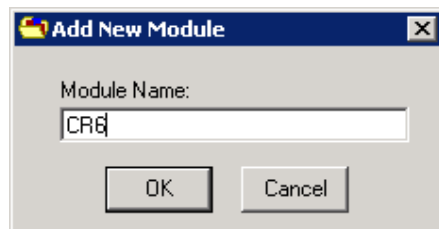

6. In the **Module Name** box, replace **Ext Bool 1** with the correct name, and click **OK**. In this example, **CR6** is entered.
7. Under **ION Map Information**, right-click **CR6** and select **New Register**. The **Edit Boolean\_Register** screen appears.
8. Update the values for **Register Label**, **Register Type**, **Modbus Address**, and **Reset Type** and click **OK**. An example is shown next.

### Use Copy to create other module and register entries

You can create multiple module and register entries by using **Copy** and **Paste** operations.

1. Right-click a module name and select **Copy**.
2. Right-click **Digital Outputs** and select **Paste** to add a copy of the module and registry entries.
3. To change the module name, right-click the module, select **Advanced Properties**, change the name for the module, and click **OK**.
4. To change the register values in the **Modbus Register Information** area:
  - **Label** - In the **Label** column, double-click the register name. Change the label and press Enter.
  - **Address** - Double-click the Modbus register address. Change the address and press Enter.
5. Repeat steps 1 through 4 above to create and update additional modules.

The following image shows an example of completed entries in the MDI console.



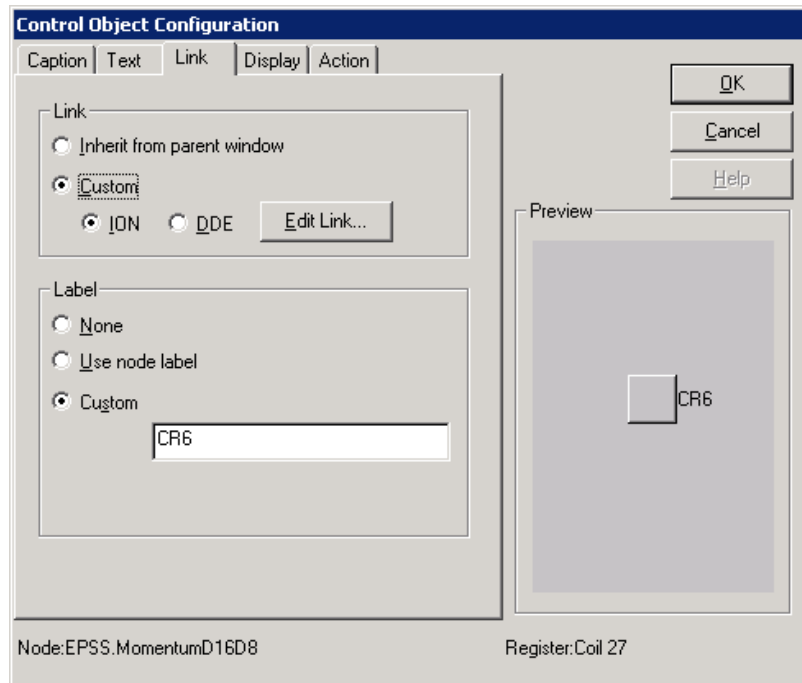

6. Under **Link**, select **Custom** and **ION**.
7. Under **Label**, select **Custom** and enter a label for the control object.
8. Under **Link**, click **Edit Link**. The **Create Link** screen appears.

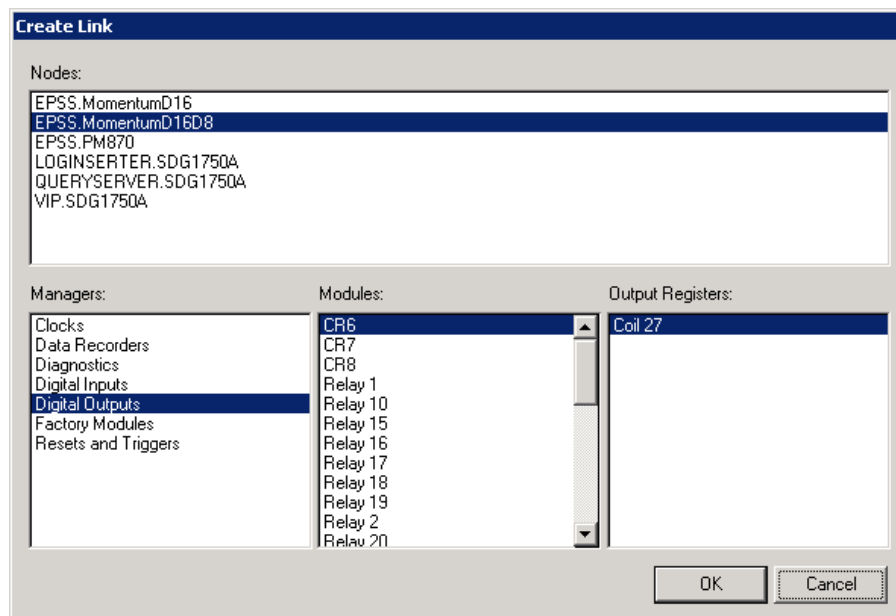

- a. In the **Nodes** box, double-click the PLC name. The module directories appear in the **Managers** box.
- b. In the **Managers** box, double-click **Digital Outputs**
- c. In the **Modules** box, double-click **CR6**.
- d. In the **Output Registers** box, select **Coil 27**.

- e. Click **OK** to save the selection and to close the screen.
- 9. In the Workspace, select a **Status Object** in the Toolbox and drag it to the workspace.
- 10. Right-click the status object. The **Status Object Configuration** screen appears.

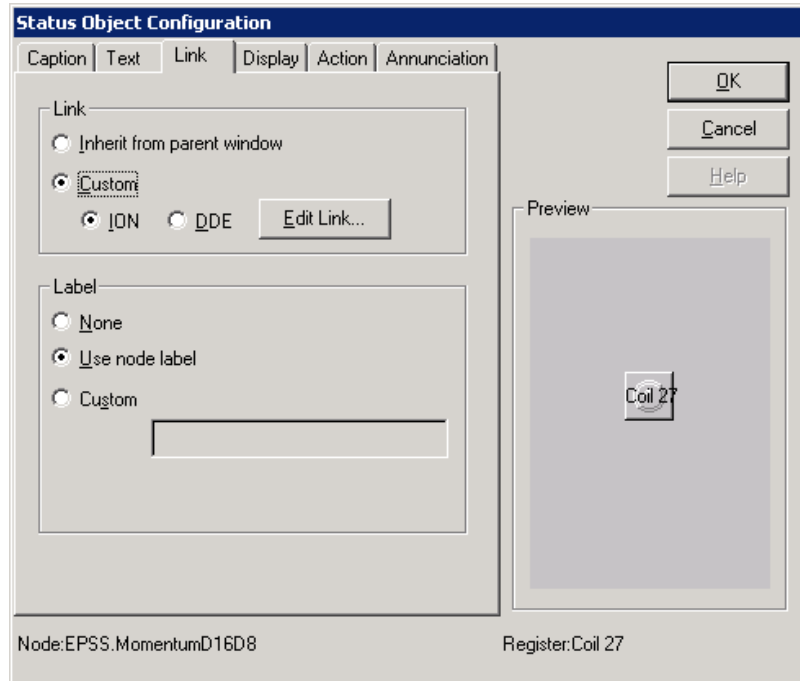

- 11. Select the **Link** tab.
- 12. Under **Link**, select **Custom** and **ION**.
- 13. Under **Label**, select **Use node label**.
- 14. Under **Link**, click **Edit Link**. The **Create Link** screen appears.
- 15. Repeat steps a. through e. above.
- 16. Save the diagram. The following image is an example of the Vista diagram.



You can now use the Control Object to initiate a state change remotely.

## Configuring SER-2408/SER-3200

The SER-2408/SER-3200 Sequence of Event Recorders can be used with the software to record status changes of the ATS and generator contacts in the onboard data logs.

SER3200 are recommended for Power Monitoring Expert - Data Center Edition.

The process to set up the SER-2408/SER-3200 with Power Monitoring Expert includes these steps:

1. Install hardware and configure device communications and digital inputs.

The SER-2408/SER-3200 can be configured using the integral webserver of the device. Enter the IP address of the device in the browser to open the setup page. Refer to *SER-3200/SER-2408 Instruction Bulletin: User's Guide* for instructions.

Perform the following steps from the *SER-3200/SER-2408 Instruction Bulletin: User's Guide* before proceeding:

2. In your browser, enter your device IP address and press **Enter**. Log in using your Login ID and password.
3. Click **SETUP**, and then click **Time**. Set the time/clock correctly for your location.

CyTime Event Recorder

MONITORING CONTROL DIAGNOSTICS **SETUP**

Communications

**Time**

Inputs

Inputs (Group)

Outputs

Groups

Administration

Date and Time: 04/27/2015 11:23:52 (UTC-08:00)

Time Source: NTP

Time Sync Master:

Time Zone Offset: UTC-08:00

Hourly Time Update:

NTP Polling Interval: 1 hour

Primary NTP Server: 131 . 107 . 13 . 100

Secondary NTP Server: 165 . 193 . 126 . 229

Last Successful NTP Sync: 04/27/2015 10:38:47 (UTC-08:00) 131.107.13.100

Manual Time Set: 2000 . 1 . 1 . 0 . 0 . 0 ← Copy PC Clock

Year Month Day Hour Minute Second

Cancel Defaults Apply

© Copyright 2009-2013, Cyber Sciences, Inc. All rights reserved.

4. Click **SETUP**, and then click **Inputs**. Configure all necessary inputs and select the **Enabled** check box next to each input. When finished, click **Apply**.

CyTime Event Recorder

MONITORING CONTROL DIAGNOSTICS **SETUP**

Communications  
Time  
Inputs  
Inputs (Group)  
Outputs  
Groups  
Administration

Enabled	Input Name	Filter	Debounce	Chatter	Off Text	On Text	Trigger	Inverted
<input checked="" type="checkbox"/>	EPSS_E_TEST	3000	3000	0	Off	On	<input type="checkbox"/>	<input type="checkbox"/>
<input checked="" type="checkbox"/>	EPSS_E_EMERGENCY	3000	3000	0	Off	On	<input type="checkbox"/>	<input type="checkbox"/>
<input checked="" type="checkbox"/>	EPSS_E_NORMAL	3000	3000	0	Off	On	<input type="checkbox"/>	<input type="checkbox"/>
<input checked="" type="checkbox"/>	EPSS_E_GEN_RUN	3000	3000	0	Off	On	<input type="checkbox"/>	<input type="checkbox"/>
<input checked="" type="checkbox"/>	Input 05	3000	3000	0	Off	On	<input type="checkbox"/>	<input type="checkbox"/>
<input checked="" type="checkbox"/>	Input 06	3000	3000	0	Off	On	<input type="checkbox"/>	<input type="checkbox"/>
<input checked="" type="checkbox"/>	Input 07	3000	20	0	Off	On	<input type="checkbox"/>	<input type="checkbox"/>
<input checked="" type="checkbox"/>	Input 08	3000	3000	0	Off	On	<input type="checkbox"/>	<input type="checkbox"/>
<input type="checkbox"/>	Input 09	20	20	0	Off	On	<input type="checkbox"/>	<input type="checkbox"/>
<input type="checkbox"/>	Input 10	20	20	0	Off	On	<input type="checkbox"/>	<input type="checkbox"/>
<input type="checkbox"/>	Input 11	20	20	0	Off	On	<input type="checkbox"/>	<input type="checkbox"/>
<input type="checkbox"/>	Input 12	20	20	0	Off	On	<input type="checkbox"/>	<input type="checkbox"/>
<input type="checkbox"/>	Input 13	20	20	0	Off	On	<input type="checkbox"/>	<input type="checkbox"/>
<input type="checkbox"/>	Input 14	20	20	0	Off	On	<input type="checkbox"/>	<input type="checkbox"/>
<input type="checkbox"/>	Input 15	20	20	0	Off	On	<input type="checkbox"/>	<input type="checkbox"/>
<input type="checkbox"/>	Input 16	20	20	0	Off	On	<input type="checkbox"/>	<input type="checkbox"/>

▲ [ 1 to 16 ] ▼ [ 17 to 24 ]

Cancel Defaults Apply

© Copyright 2009-2013, Cyber Sciences, Inc. All rights reserved.

5. Click **SETUP**, and then click **Groups**. Assign a group to each input. When finished, click **Apply**.

CyTime Event Recorder

MONITORING CONTROL DIAGNOSTICS **SETUP**

Communications  
Time  
Inputs  
Inputs (Group)  
Outputs  
Groups  
Administration

#	Input Name	Data Log Group
01	EPSS_E_TEST	Group 01
02	EPSS_E_EMERGENCY	Group 01
03	EPSS_E_NORMAL	Group 01
04	EPSS_E_GEN_RUN	Group 01
05	Input 05	None
06	Input 06	Group 01
07	Input 07	Group 02
08	Input 08	Group 03
09	Input 09	Group 04
10	Input 10	Group 05
11	Input 11	Group 06
12	Input 12	Group 07
13	Input 13	Group 08
14	Input 14	None
15	Input 15	None
16	Input 16	None

▲ 1 to 16 ▼ 17 to 24

Cancel Defaults Apply

© Copyright 2009-2013, Cyber Sciences, Inc. All rights reserved.

6. Make sure that you enable logging for all above groups.

## NOTICE

**UNINTENDED OPERATION**

Make sure to enable the logs in the groups section when configuring the device.

**Failure to enable the logs in the groups section will result in the inputs not being available and not appearing in the Generator Performance Tool.**

For more information on configuring the communications and digital inputs for this device, see the *SER-3200/SER-2408 Instruction Bulletin: User's Guide* located on the Power Monitoring Expert DVD.

7. Add the device in Management Console.
8. Open Vista to verify communications.
9. Use the Generator Performance Configuration Tool to assign measurements for generators or ATS equipment.

See the following sections for instructions on step 2 - 4.

After you complete the above steps, you can generate the EPSS or Generator Test Report for data recorded by the SER-2408/SER-3200.

## WARNING

### UNINTENDED OPERATION

- Do not use the SER-2408/SER-3200 with either Power Monitoring Expert or ION Setup for critical control or protection applications where human or equipment safety relies on the operation of the control circuit.
- Refer to your power meter's technical documentation located on the product DVD for more information on its operation.

**Failure to follow these instructions can result in death, serious injury, or equipment damage.**

## Adding the SER-2408/SER-3200 to Management Console

In Management Console, add the SER-2408/SER-3200 as an Ethernet device.

For proper operation, the device must have the **Unit ID** value set to 1.

Follow these steps to set the device **Unit ID**:

1. As you enter the device details in the Ethernet Device Configuration screen, right-click the screen and click **Advanced**.

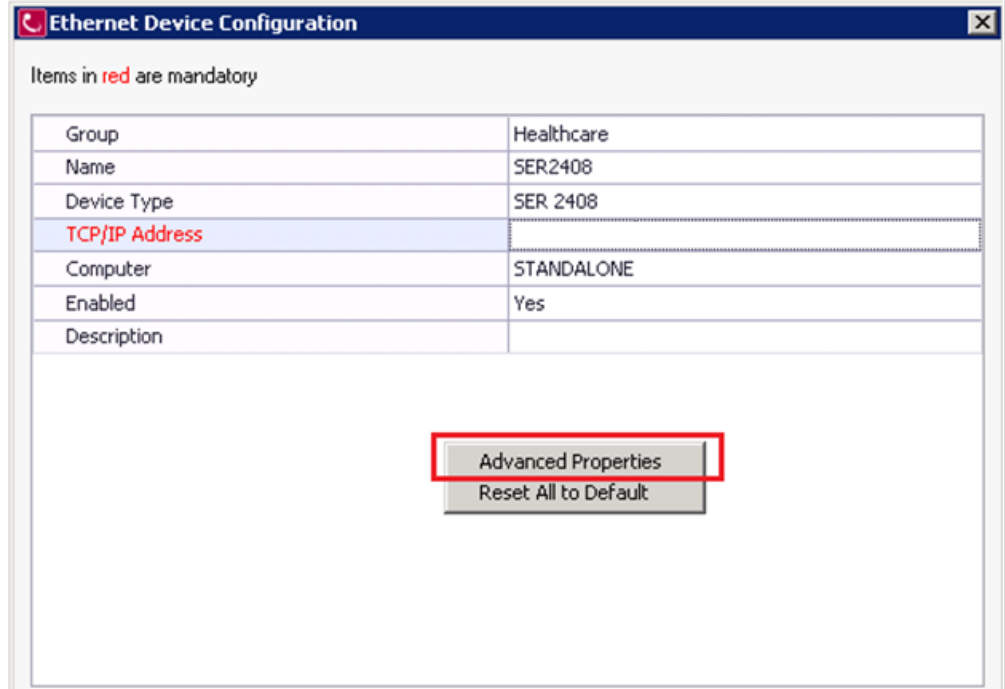

The image shows a software dialog box titled "Ethernet Device Configuration". At the top, it states "Items in red are mandatory". Below this is a table with the following data:

Group	Healthcare
Name	SER2408
Device Type	SER 2408
TCP/IP Address	
Computer	STANDALONE
Enabled	Yes
Description	

Below the table are two buttons: "Advanced Properties" and "Reset All to Default". The "Advanced Properties" button is highlighted with a red rectangular border.

The Advanced Properties for the device appear.

2. In the Unit ID field, enter 1.

**Ethernet Device Configuration**

Group	Healthcare
Name	SER2408
Device Type	SER 2408
TCP/IP Address	
TCP/IP Port	502
Computer	STANDALONE
Enabled	Yes
Description	
Receive Timeout	10000
Maximum Attempts Multiple	3
Attempt Increment	3
Online Event Priority	10
Offline Event Priority	128
Offline Attempt Number	1
Offline Timeout Period	20000
Unit ID	1
Transmit Delay	0

Unit ID  
Unit ID of the Ethernet device.

OK Cancel

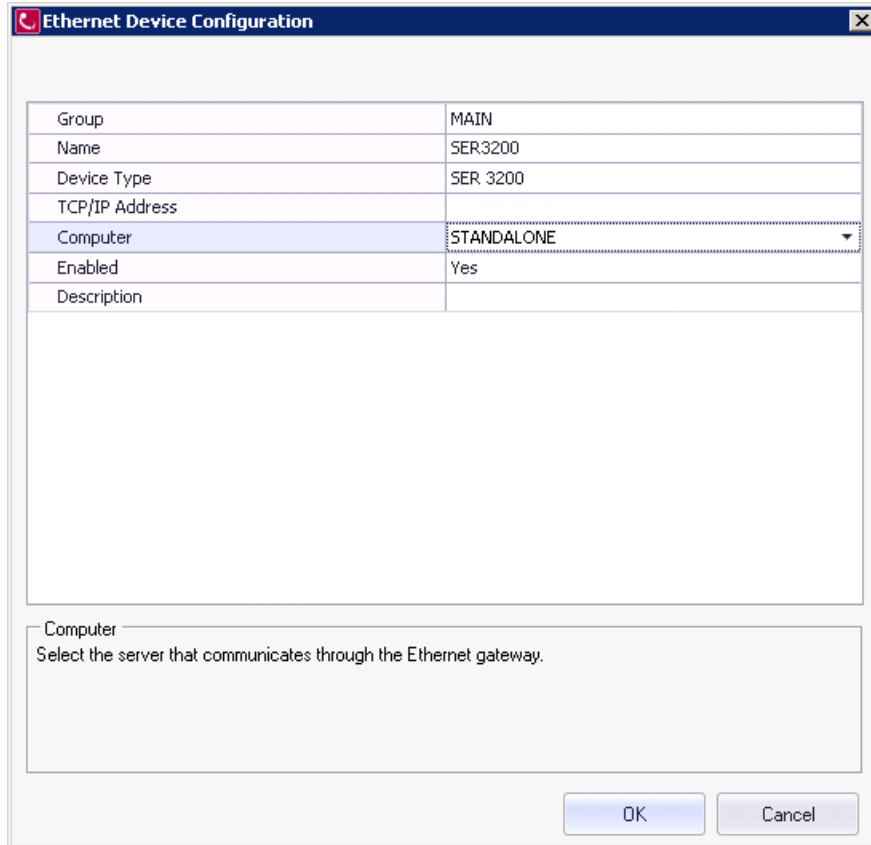

3. Click **OK**.
4. Verify the device status is "Device Connected" as shown next.

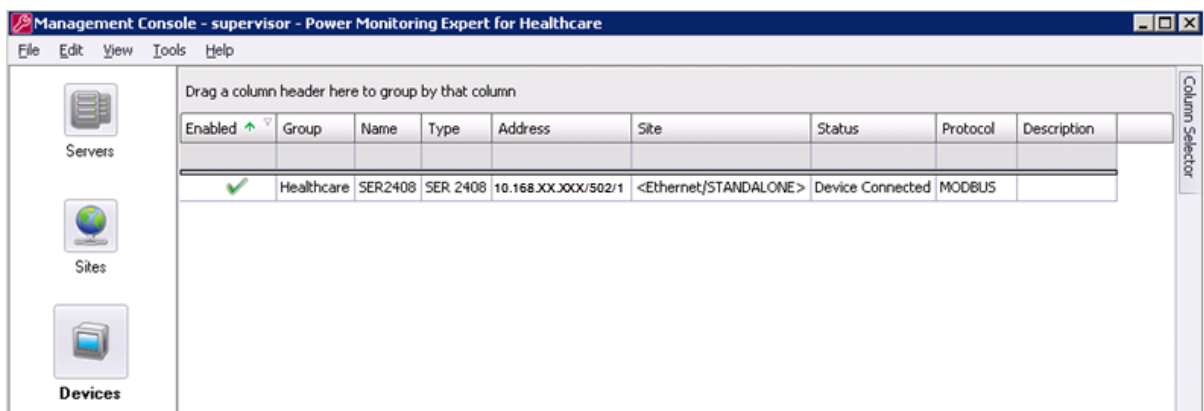

## Verify Device Communications in Vista

After you add the device to Management Console, you can open Vista to view the device's counter, input/output status, and data logs.

The following examples show the device diagram and recorded data details.

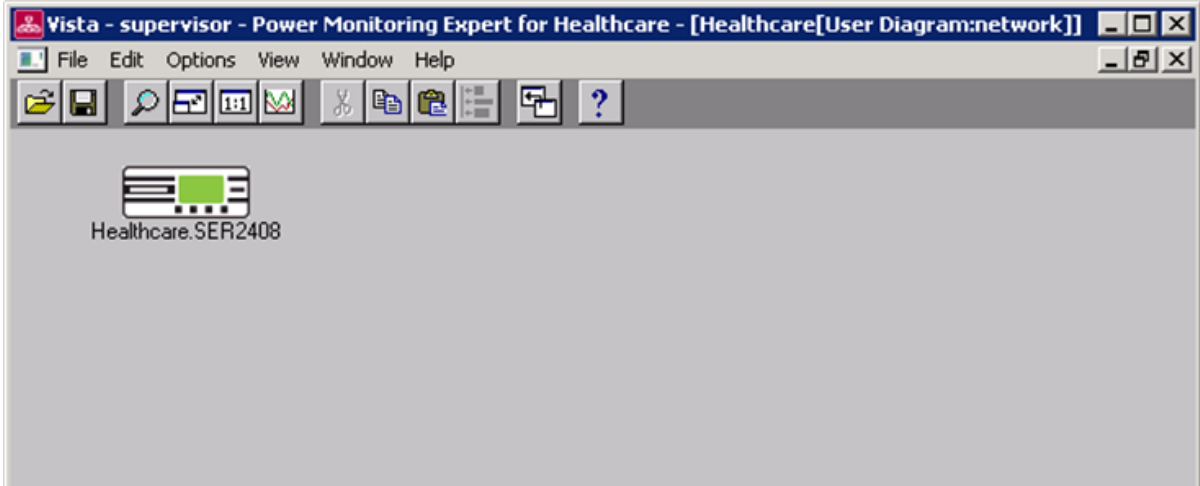

Healthcare.SER2408

Monitoring    Resets    Current Configuration    Diagnostics    [Back to Network](#)

**Digital Input**

Channel Name	Status	Count	Channel Name	Status	Count
01 Input 01	Off	0	13 Input 13	Off	0
02 Input 02	Off	0	14 Input 14	Off	0
03 Input 03	Off	0	15 Input 15	Off	0
04 Input 04	Off	0	16 Input 16	Off	0
05 Input 05	Off	0	17 Input 17	Off	0
06 Input 06	Off	0	18 Input 18	Off	0
07 Input 07	Off	0	19 Input 19	Off	0
08 Input 08	Off	0	20 Input 20	Off	0
09 Input 09	Off	0	21 Input 21	Off	0
10 Input 10	Off	0	22 Input 22	Off	0
11 Input 11	Off	0	23 Input 23	Off	0
12 Input 12	Off	0	24 Input 24	Off	0

**Relay Output**

Channel Name	Status	Count	Channel Name	Status	Count
01 Output 01	Off	0	05 Output 05	Off	0
02 Output 02	Off	0	06 Output 06	Off	0
03 Output 03	Off	0	07 Output 07	Off	0
04 Output 04	Off	0	08 Output 08	Off	0

Device Time 9/11/2013 02:41:01.000 PM  
Device Type SER2408

211x20 Numeric Object: Relay Output 8 Label@Healthcare.SER2408    2:41 PM

## Assign Measurements for Generators or ATS Equipment

After device data is logged into the database, you can assign device measurements using the Generator Performance Configuration Tool Generator Performance Configuration Tool with EPSS Test Module.

Add the device and select the measurements for the generator or ATS, as explained in these sections:

- ["Define Generators for EPSS" on page 42](#)
- ["Define Generators" on page 91](#)
- ["Define Transfer Switches for EPSS" on page 51](#)

The required status measurements for the SER-2408/SER-3200 SER3200 are "Digital Input Status X" where X = input of the SER-2408/SER-3200 SER3200. On the **Generators** tab, the selected source and measurement are similar to the following example.

Status Measurements	
Source:	SER.2408
<input type="checkbox"/> Starting:	Active Value
No Measurement selected.	1
<input checked="" type="checkbox"/> Running:	Active Value
Digital Input 1 Status	1
<input type="checkbox"/> Stopped:	Active Value
Digital Input 2 Status	1



# Interpreting the Energy Regression Analysis Report results

The Energy Regression Analysis Tool is a highly configurable tool that allows you to monitor and manage a building or facility's energy and resource consumption. This practice, called energy modeling, involves analyzing building energy systems, monitoring energy consumption, and detecting anomalies or changes in system behavior that may require that you perform energy efficiency upgrades or fixes. The Energy Regression Analysis Report allows you to model energy data one independent variable at a time with a wide range of desired independent variables, such as weather or occupancy rate.

It is recommended that users have a basic understanding of energy modeling and understand how to create an Energy Regression Analysis Report. This section discusses in detail the purpose of each parameter in the report and how to read and interpret meaningful results of an Energy Regression Analysis Report. After generating the report, conclusions can be drawn from the generated tables and charts to monitor energy consumption and make cost saving decisions.

Energy Regression Analysis Report results provide a characterization of a building's performance. You can perform different types of energy analysis with this information, including the following:

- Energy Benchmarking
- Energy Budgeting
- Energy Savings

## Glossary of terms

Term	Definition
Cooling Degree Days (CDD)	Measurement designed to reflect the demand for energy needed to cool a building.
Cost Savings Analysis	Comparing energy profiles against expected profiles and identifying outlying data that may signify areas of improvement.
Degree Day	One degree of departure, on a single day, of the daily mean temperature from a given standard temperature.
Energy Benchmarking	Comparing the energy performance of similar buildings, or comparing the energy performance of a single building over time.
Energy Budgeting	Determining future energy use and associated costs for different times of the year.
Energy Modeling	Computerized simulation of a building that focuses on energy consumption, utility bills and life cycle costs of various energy related items such as air conditioning, lights and hot water.
Energy Savings	Measuring savings by comparing performance profiles before and after energy efficiency modifications.

Energy Use Breakdowns	Disaggregating building energy into different categories, such as weather-dependent energy use or weather-independent energy use.
Heating Degree Days (HDD)	Measurement designed to reflect the demand for energy needed to heat a building.
Performance (Regression) Line	The statistical line of best fit.
Regression Analysis	Statistical process for estimating the relationships among variables. Includes many techniques for modeling and analyzing several variables, when the focus is on the relationship between a dependent variable and one or more independent variables.

## Reading the report

This section discusses how to read the different types of information in the report.

For information on how to configure and use this report, see ["Configure and Generate the Energy Regression Analysis Report" on page 27](#).

### Report Parameters Summary table

The Report Parameters Summary table appears at the beginning of the report. Based on what you select for the **Show Report Parameters Summary** option on the prerequisite page, you can make this table appear or be hidden in the report.

#### Report Parameters Summary

<b>Driver Data Source</b>	WeatherStation.VancouverBC	<b>Driver Data Quantity</b>	Weather Temperature (°C)
<b>Model Data Source</b>	GasIncomer.GasMeter	<b>Model Data Quantity</b>	Natural Gas Volume (m <sup>3</sup> )
<b>X Axis Calculation Method</b>	Average	<b>Degree Days Pivot Point</b>	18
<b>Y Axis Calculation Method</b>	Delta		
<b>Regression Type</b>	Broken Line	<b>Aggregation Period</b>	Week
<b>Deviation Type</b>	Absolute Value	<b>Max Authorized Deviation</b>	330

This table provides important details, such as data sources, calculation methods, and other parameters about how the report inputs are configured that can help the user understand report results.

### Regression Analysis Chart

The Regression Analysis Chart shows the relationship between the driver and model data.

In this chart, the blue dots represent real data points. In this case, the data is aggregated weekly over the course of one year, therefore, there are 52 data points with each data point representing one week of the year. The yellow line is the regression line, or performance line, of the building. The performance (regression) line is the best fit line—a line that indicates the expected energy consumption. The slope of the performance line is a measure of how much extra fuel, energy, or other resource is consumed for an increase in the independent variable (such as degree days, production units, and so forth).

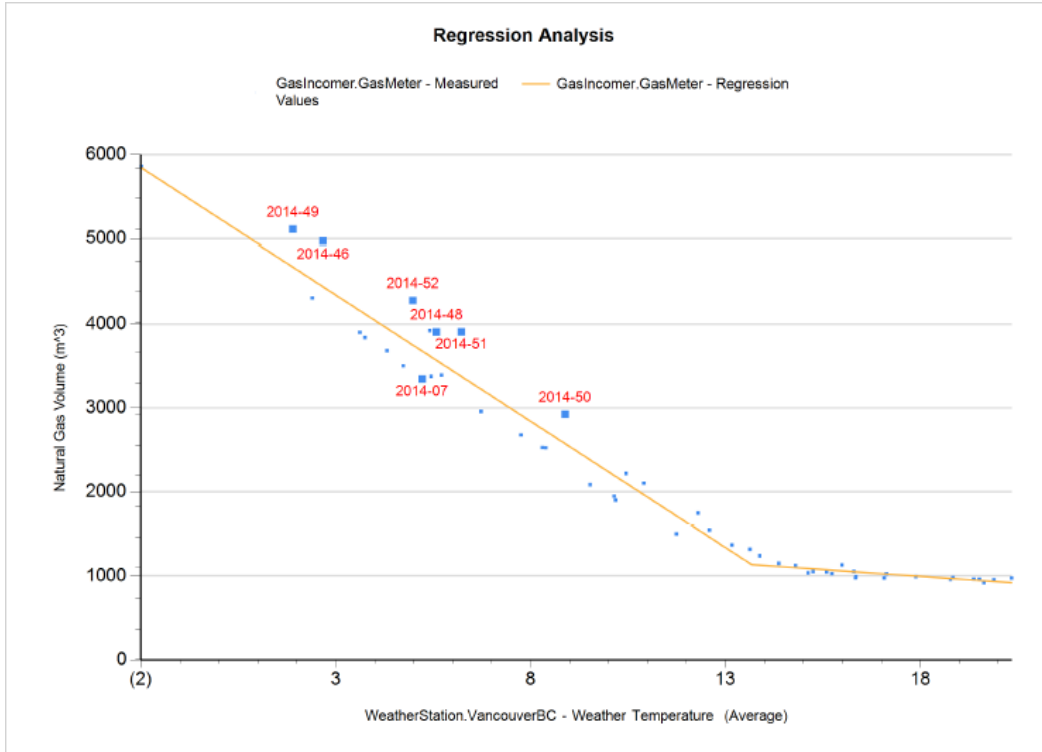

Deviations between building performance lines over time means that something has changed in the way the facility consumes energy. This may be a result of energy efficiency modifications, or it could indicate an issue with building systems, equipment, or processes. The performance line provides a benchmark by which changes in energy consumption can be monitored, and appropriate actions can be taken if variations are detected.

The point of intersection between the two performance lines is called the breakpoint. For energy consumption analyzed with respect to average temperature, the breakpoint indicates the temperature at which heating or cooling of a facility begins. Therefore, having a breakpoint further to the right is better because this indicates that heating or cooling systems are running for less time, which results in less energy usage.

**Regression Analysis Main Characteristics Table**

The Regression Analysis Main Characteristics Table provides information about the Regression Analysis Chart.

**Regression Analysis Main Characteristics Tables**

Side	Slope	Y-Intercept	R <sup>2</sup>	RMSE
Left	-300.67	5257.20	-0.971	290.14
Right	-32.52	1581.66	-0.822	43.92

	X Value	Y Value
Changepoint	13.71	1135.97

The **Side** column shows the left and right sides. The **Slope** column shows the slope values of the two best-fitting lines intersect.. This intersection point is called the *breakpoint*. The **Y-Intercept** column shows a point where the graph of a function or relation intersects with the y-axis of the coordinate system. Therefore, these points satisfy  $x = 0$ .

The **R2** column shows a value that indicates how well the data fits the model. The **RMSE** column shows the square root of the mean/average of the square of all of the error. The **X Value** and **Y Value** columns show the coordinates of the Change point.

Monitoring the slopes and breakpoint values provides useful information about a facility's energy consumption. Flatter slope lines are better as they indicate a smaller increase in energy consumption for every additional unit of the independent X-axis variable.

For more information on interpreting the report results, see ["Interpreting the report" on page 264](#).

### Measured Values Against Expected Values Chart

The Measured Values Against Expected Values Chart shows the relationship between the model data and time.

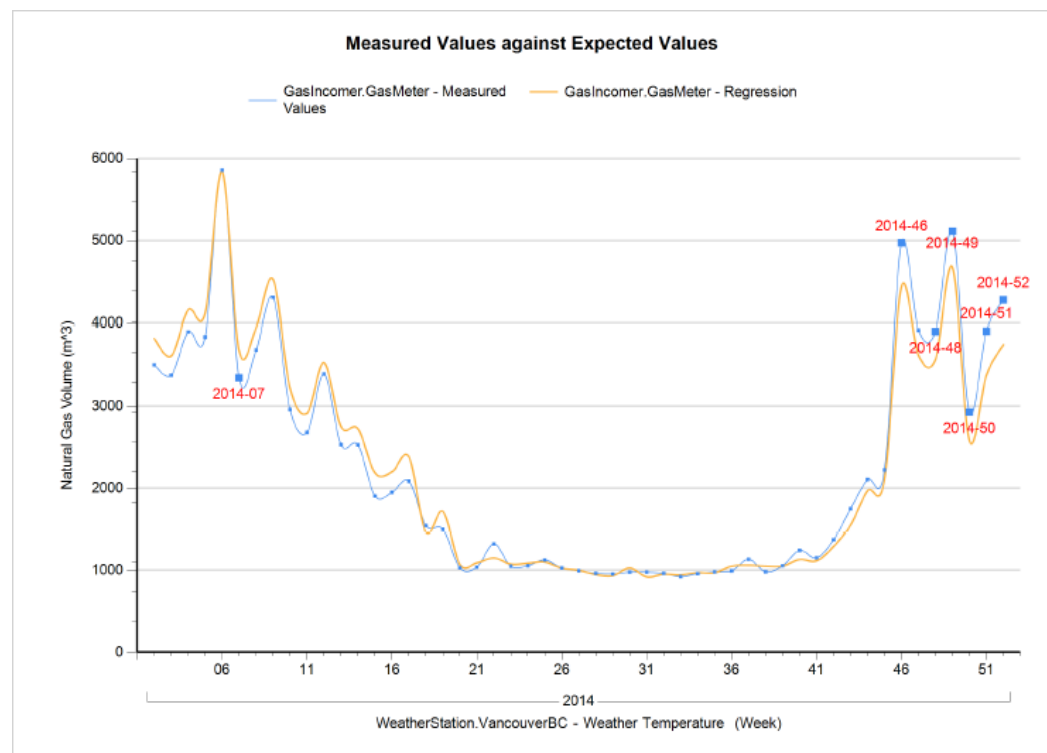

In this chart, the blue line indicates the real energy usage over time and the performance line indicates the expected energy usage over time based on the regression analysis.

The time axis, or X-axis, has different units depending on the selected aggregation period. For weekly aggregation, the numbers on the X-axis represent the weeks of the year and for daily aggregation, they represent the days of the year. The year or years contained within the reporting period are displayed on the chart directly below the X-axis values.

### Exceptions Table

The Exceptions Table below shows information for any data point that falls outside of the exception range defined by the Deviation Type and Max Authorized Deviation parameters.

#### Exceptions Table

Device Name	Aggregation Period (Week)	X-Axis Value (Average)	Y-Axis Value (m <sup>3</sup> )	Regression Value (m <sup>3</sup> )	Delta Value (m <sup>3</sup> )	Delta Value Percent (%)
GasIncomer.GasMeter	2014-49	1.94	5116.00	4674.06	441.94	9.46 %
GasIncomer.GasMeter	2014-46	2.71	4974.30	4442.87	531.43	11.96 %
GasIncomer.GasMeter	2014-52	5.02	4281.00	3749.08	531.92	14.19 %
GasIncomer.GasMeter	2014-07	5.26	3344.70	3676.72	-332.02	-9.03 %
GasIncomer.GasMeter	2014-48	5.62	3904.60	3567.70	336.90	9.44 %
GasIncomer.GasMeter	2014-51	6.26	3907.00	3374.41	532.59	15.78 %
GasIncomer.GasMeter	2014-50	8.92	2925.00	2574.40	350.60	13.62 %

If there are no exception points, this table does not appear in the report.

### Full Table

The Full Table below shows information for all data points.

#### Full Table

Device Name	Aggregation Period (Week)	X-Axis Value (Average)	Y-Axis Value (m <sup>3</sup> )	Regression Value (m <sup>3</sup> )	Delta Value (m <sup>3</sup> )	Delta Value Percent (%)
GasIncomer.GasMeter	2014-06	-1.95	5859.70	5844.23	15.47	0.26 %
GasIncomer.GasMeter	2014-49	1.94	5116.00	4674.06	441.94	9.46 %
GasIncomer.GasMeter	2014-09	2.43	4309.50	4525.20	-215.70	-4.77 %
GasIncomer.GasMeter	2014-46	2.71	4974.30	4442.87	531.43	11.96 %
GasIncomer.GasMeter	2014-04	3.65	3900.87	4158.31	-257.44	-6.19 %
GasIncomer.GasMeter	2014-05	3.79	3839.60	4118.93	-279.33	-6.78 %
GasIncomer.GasMeter	2014-08	4.35	3681.70	3948.91	-267.21	-6.77 %
GasIncomer.GasMeter	2014-02	4.77	3501.95	3823.01	-321.06	-8.40 %
GasIncomer.GasMeter	2014-52	5.02	4281.00	3749.08	531.92	14.19 %
GasIncomer.GasMeter	2014-07	5.26	3344.70	3676.72	-332.02	-9.03 %
GasIncomer.GasMeter	2014-47	5.45	3922.70	3618.82	303.88	8.40 %
GasIncomer.GasMeter	2014-03	5.48	3376.11	3608.86	-232.75	-6.45 %
GasIncomer.GasMeter	2014-48	5.62	3904.60	3567.70	336.90	9.44 %
GasIncomer.GasMeter	2014-12	5.75	3391.40	3527.70	-136.30	-3.86 %
GasIncomer.GasMeter	2014-51	6.26	3907.00	3374.41	532.59	15.78 %
GasIncomer.GasMeter	2014-10	6.76	2959.10	3223.53	-264.43	-8.20 %
GasIncomer.GasMeter	2014-11	7.79	2679.40	2914.45	-235.05	-8.06 %
GasIncomer.GasMeter	2014-13	8.34	2528.80	2749.79	-220.99	-8.04 %
GasIncomer.GasMeter	2014-14	8.43	2526.00	2723.49	-197.49	-7.25 %
GasIncomer.GasMeter	2014-50	8.92	2925.00	2574.40	350.60	13.62 %
GasIncomer.GasMeter	2014-17	9.57	2085.60	2381.11	-295.51	-12.41 %

Within the Full Table, there is a row with missing values.

Warp.GeneratorOne	2009-8	12.63	73.74	51.70	-22.04	-42.64 %
Warp.GeneratorOne	-	15.14		62.07		
Warp.GeneratorOne	2009-7	16.83	150.60	122.89	-27.71	-22.55 %

This row stores information about the breakpoint from the Regression Analysis Chart.

This report generates with almost any set of data and regardless of other parameter selections. However, the generated report is only of assistance in monitoring energy consumption if the parameters are configured correctly and with specific intent.

The following section provides specific examples of how to use the Energy Modeling Report to monitor certain aspects of a facility's energy consumption.

## Interpreting the report

After generating the report, the data can be analyzed in different ways to draw different conclusions about energy and resource consumption. Below are two examples involving different independent variables.

### Example 1: Justifying Energy Efficiency Upgrades

Regression analysis of energy or resource consumption with respect to Degree Days can provide valuable information about a facility's energy efficiency with respect to outside changes in temperature. Such information can be used to determine when energy efficiency upgrades are necessary, and to monitor the effectiveness of such solutions after implementation.

For example, a facility manager could compare the Heating Degree Day energy profile of their building to another facility in a similar climate. If the other building proves to be much more energy efficient, an analysis could be performed on the differences in building design that could cause these results. Perhaps the only significant difference is that the more efficient building recently upgraded their insulation. The less efficient building could then use this information, along with the Regression Analysis charts to pitch the case that an insulation upgrade should take place to reduce natural gas usage at the facility.

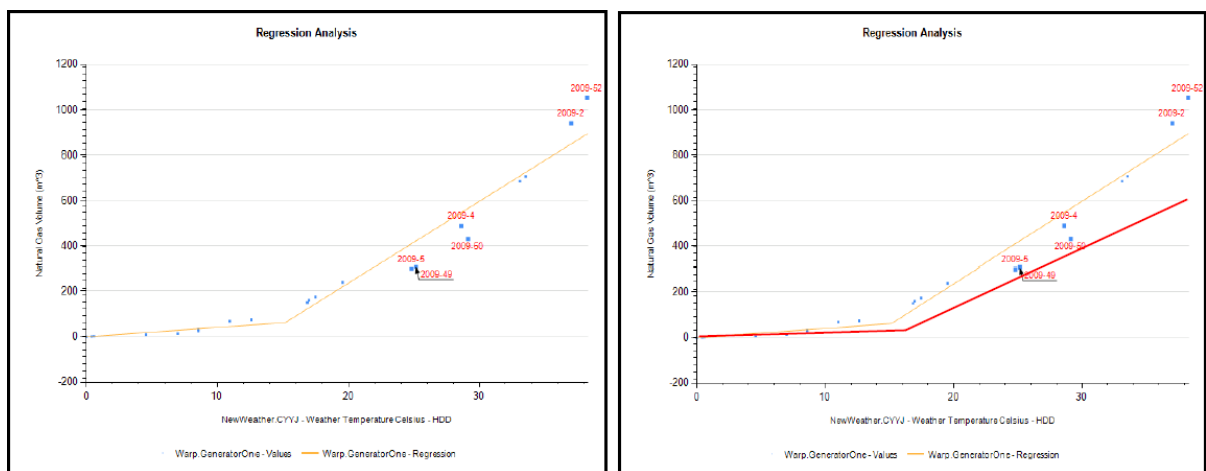

If the upgrade is successful, a change appears in the Regression Analysis chart the following year. The chart above shows a possible Regression analysis for the year before the energy efficiency modifications. The red line in the chart shows how the performance lines and breakpoint could change when the upgrades are successful. The slopes of the lines in the

second figure are flatter, indicating less energy usage for every additional degree day. The breakpoint also occurs later, indicating that heating does not have to begin at as low of a temperature as before, thereby saving additional resources.

**Example 2: Identifying Equipment Failure**

Regression analysis can also be used to detect equipment deterioration or failure. Below are two Regression Analysis charts showing natural gas consumption with respect to production units.

The red line in the chart has a steeper slope and an earlier X-axis intersection point. This indicates that more natural gas is being used for every unit of production. If data for these charts is collected over different periods of time, but with no changes to manufacturing processes or equipment, the steeper regression line in the second chart could indicate deterioration of equipment.

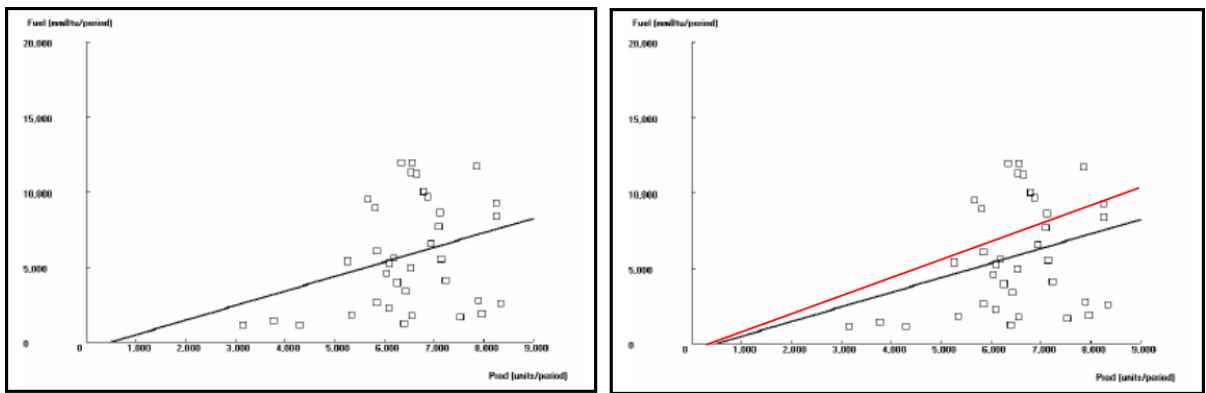

Plotting energy consumption data against any independent variable, not just time, allows you to analyze in greater detail the energy efficiency of your buildings or facilities, and to make necessary upgrades or cost analysis decisions.

**Conclusion**

Energy modeling is a relatively new practice for monitoring and analyzing energy consumption in buildings and facilities. It involves using computerized simulations to analyze energy consumption, and it allows customers to understand their expected energy consumption and use this information to make system design decisions and perform cost benefit analysis.

The Energy Modeling Report, or XY Regression Report, allows users to create energy profiles for their buildings or facilities. These benchmark energy models provide valuable information about energy and resource consumption that can help facility managers identify and address consumption issues in order to save resources.

**Recommendations**

Many of the report parameters on the prerequisite page are interdependent and configuring this page requires close attention. It is recommended to rely on documentation to correctly configure the report. Note that there is no filtering of parameters on the prerequisite page.

## Generator System Redundancy Types

You can create a generator system to achieve power redundancy for IT equipment loads in different ways, depending on how the generators are grouped together and how they are connected to the equipment power supplies. This configuration tool supports several industry standard configurations.

The generator system supports the following redundancy design types:

"N Type"

"N+1 Type"

"N+2 Type"

"2N Type"

"2(N+1) Type"

"2(N+2) Type"

Before generator-related reports can be produced you need to define a generator system in the Generator Power Configuration Utility.

### N Type

The N system configuration is for one or more generators that work together to supply power to the IT load, when the utility or utilities' power is unavailable. There is no redundancy. The intention is to size the generator system to match the peak IT load on the utility power.

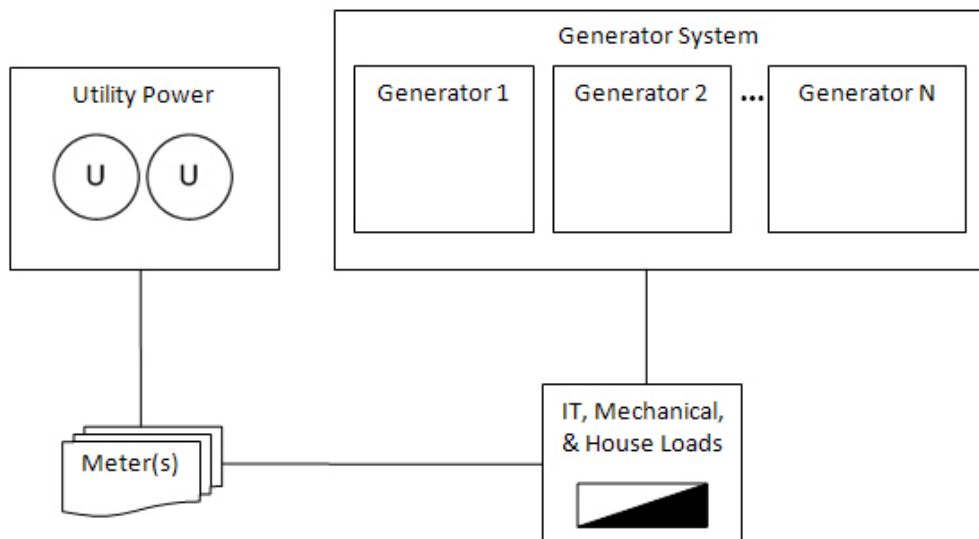

## N+1 Type

The N+1 system configuration is for one or more generators that work together to supply power to the IT load. There is simple generator redundancy in that one of the generators can stop functioning or be taken off-line, in the event that the utility power is interrupted. The load is spread among all generators, but the peak load is such that if one generator stops working, the others will be able to assume its load. Another way to look at it is, N generators will be able to support the peak IT load. If the peak IT load is more than N can support, then system design redundancy will be lost.

For example, if three generators are connected to the IT loads, in an N+1 system, the peak utility load must not exceed the non-redundant capacity of two of the generators. If it does, the designed redundancy will be lost.

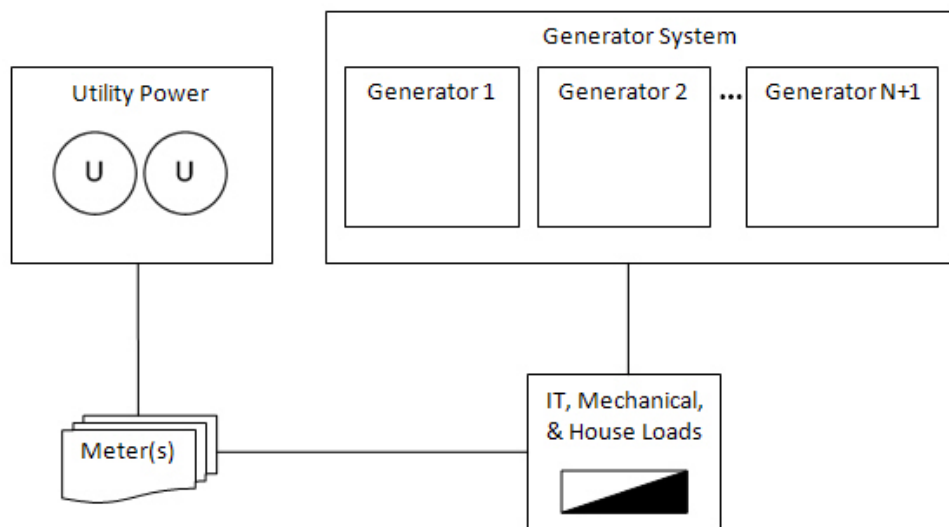

## N+2 Type

The N+2 system configuration is for a group of generators that work together to supply power to a medium voltage substation and is then distributed to low voltage loads. There is simple generator redundancy in that any two of the generators can stop functioning or be taken off-line, in the event that the utility power is interrupted. The load is spread among all generators, but the utility peak load is such that if two generators stop working, the others will be able to assume their load. Another way to look at it is, N generators will be able to support the peak utility load. If the peak utility load is more than N can support, then system design redundancy will be lost.

For example, if five generators are connected to the IT loads, in an N+2 system, the peak utility load must not exceed the non-redundant capacity of three of the generators. If it does, the designed redundancy will be lost.

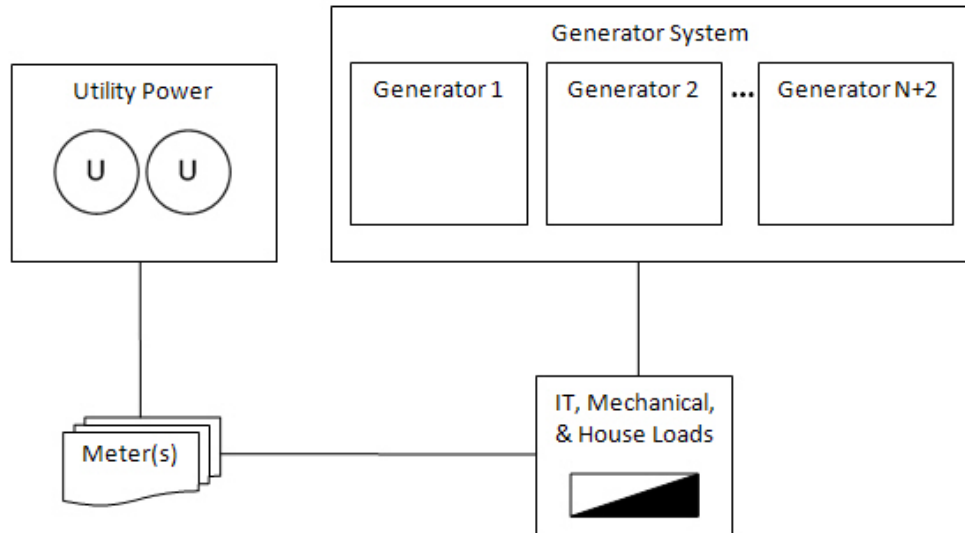

## 2N Type

The 2N system configuration is for two groups of generators that supply power to the IT loads. In a 2N system, an entire group of generators can stop functioning or be taken off-line and the equipment will still be supplied with power, in the event that the utility power is interrupted. The load is spread among all generators, but the peak load is such that, if an entire group of generators stop working, the remaining generators will be able to assume the entire load. Another way to look at it is, N generators will be able to support the peak utility load. If the peak utility load is more than N can support, then system design redundancy will be lost.

In this example, there are two groups with three generators in each. In a 2N configuration, one group of generators can go offline and the system will still have the designed redundancy. Therefore, the value for N is three. So, the total peak utility load cannot exceed the derated nameplate of three of the generators.

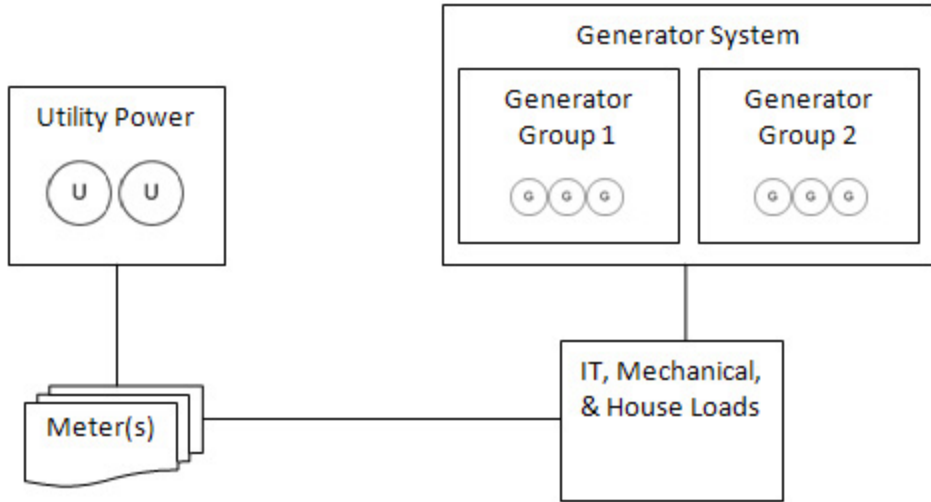

### 2(N+1) Type

The 2(N+1) system configuration is for two groups of generators that supply power to the IT loads. In an 2(N+1) system, an entire group of generators plus one more generator from each of the remaining groups can stop functioning or be taken off-line, and the equipment will still be supplied with power, in the event that the utility power is interrupted. The load is spread among all generators, but the peak load is such that if an entire group's worth of generators goes offline, plus one more from each of the other groups stop working, the remaining generators will be able to assume the entire load. Another way to look at it is, N generators will be able to support the peak utility load. If the peak utility load is more than N can support, then system design redundancy will be lost.

In this example, there are two groups with five generators in each. In a 2(N+1) configuration, one group of generators can go offline, plus one more generator from the remaining group and the system will still have the designed redundancy. Therefore, the value for N is four. So, the total peak utility load cannot exceed the derated nameplate of four of the generators.

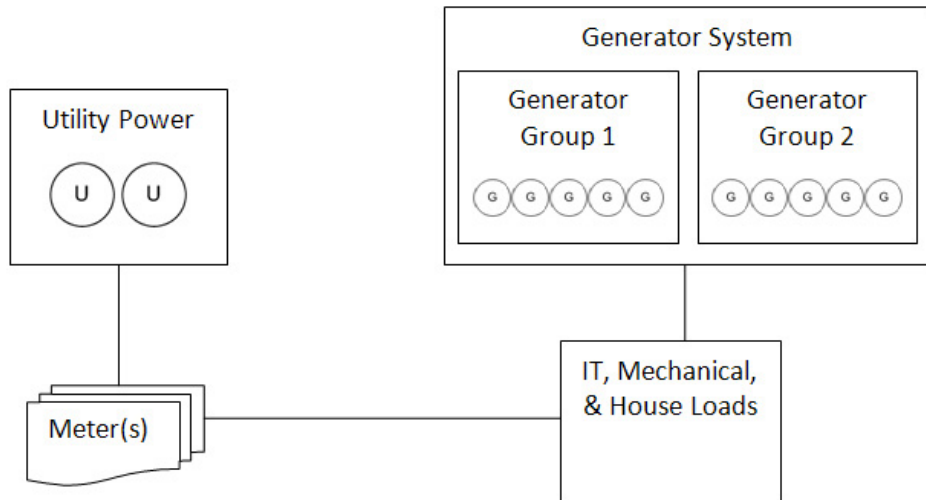

## 2(N+2) Type

The 2(N+2) system configuration is for two groups of generators that supply power to the IT loads. In an 2(N+2) system, an entire group of generators plus two more generators from each of the remaining groups can stop functioning or be taken off-line and the equipment will still be supplied with power, in the event that the utility power is interrupted. The load is spread among all generators, but the peak load is such that if an entire group's worth of generators goes offline, plus two more from each of the other groups goes offline, the remaining generators will be able to assume the entire load. Another way to look at it is, N generators will be able to support the peak utility load. If the peak utility load is more than N can support, then system design redundancy will be lost.

In this example, there are two groups with four generators in each. In a 2(N+2) configuration one group of generators can stop working, plus two more generators from the remaining group and the system will still have the designed redundancy. Therefore, the value for N is two. So, the total peak utility load cannot exceed the derated nameplate of two of the generators.

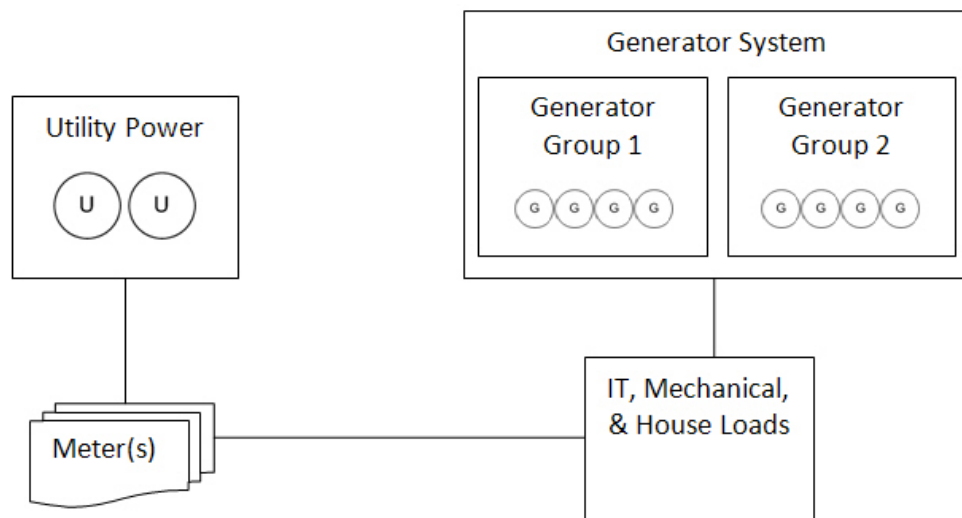

## UPS System Redundancy Types

You can create a UPS system to achieve power redundancy for IT equipment loads in different ways, depending on how the UPS units are grouped together and how they are connected to the equipment power supplies. This configuration tool supports several industry standard configurations.

The UPS system supports the following redundancy design types:

"N Type"

"N+1 Type"

"N+2 Type"

"2N Type"

"UPS System Redundancy Types"

"UPS System Redundancy Types"

## N Type

The N system configuration is for one or more UPS modules which work together to supply power to the IT load. There is no redundancy, except optionally to the second power supply of each piece of equipment.

Each UPS system with an N configuration can have multiple UPS groups, where each group is connected to a different load. The number of modules within each UPS group can be different. Within each group, all UPS modules must have the same derated nameplate rating value (kW).

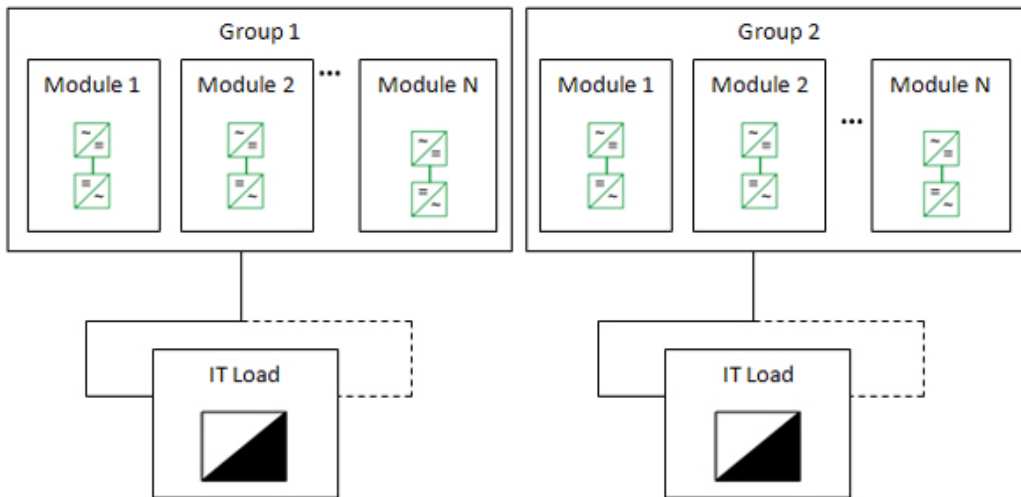

## N+1 Type

The N+1 system configuration is for one or more UPS modules that work together to supply power to the IT load. There is simple module redundancy in that one of the modules can be rendered inoperative or be taken off-line. The load is spread among all remaining UPS modules, but the peak load is such that if one module stops working, the others will be able to assume its load. Another way to look at it is, N UPS modules will be able to support the peak IT load. If the peak IT load is more than N can support, then system design redundancy will be lost.

There is the option to connect the system of modules to the second power supply of each piece of equipment, but both power supplies are connected to the group of UPS modules.

Each UPS system with an N+1 configuration can have multiple UPS groups, where each group is connected to a different load. The number of modules within each UPS group can be different. The modules within a UPS group must have the same derated nameplate rating value (kW).

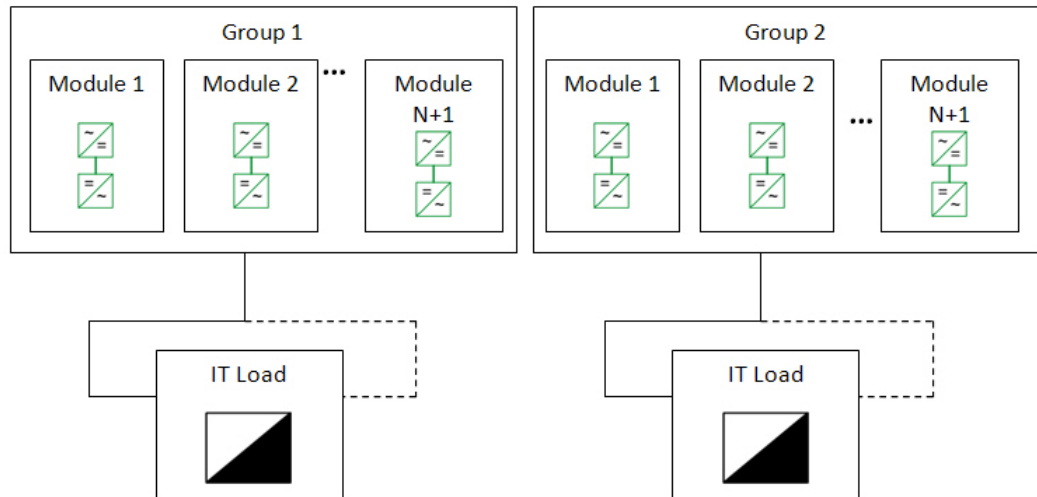

## N+2 Type

The N+2 system configuration is for a group of UPS modules that work together to supply power to the IT load. There is simple module redundancy in that any two of the modules can be rendered inoperative or be taken off-line. The load is spread among all remaining UPS modules, but the peak load is such that if two modules stop working, the others will be able to assume their load. Another way to look at it is, N UPS modules will be able to support the peak IT load. If the peak IT load is more than N can support, then system design redundancy will be lost. An example of an N+2 system is five UPS modules connected to the IT load, but the peak IT load never exceeds the capacity of three of the UPS modules.

There is the option to connect the system of modules to the second power supply of each piece of equipment, but both power supplies are connected to the group of UPS modules.

Each UPS system with an N+2 configuration can have multiple UPS groups, where each group is connected to a different load. The number of modules within each UPS group can be different. The modules within a UPS group must have the same derated nameplate rating value (kW).

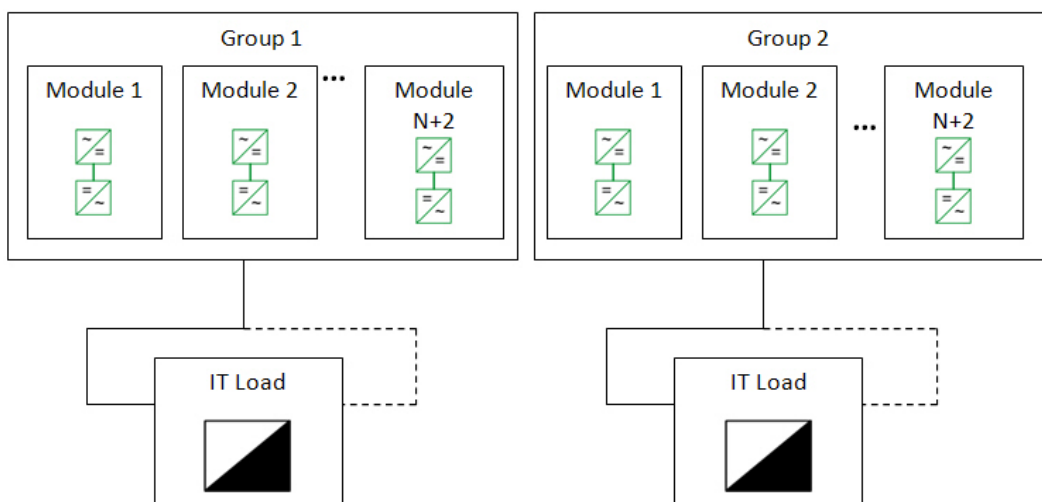

## 2N Type

The 2N system configuration is for two or three groups of UPS modules that supply power to two different power supplies in each IT load. For redundancy, an entire UPS group can stop working or be taken off-line, and the IT equipment will still be supplied with power. It also means that either one of the two power supplies in an IT load can be rendered inoperative. The load is spread among all UPS modules, but the peak load is such that if an entire group's worth of modules are not working, the remaining modules will be able to assume their load. Another way to look at it is, N UPS modules will be able to support the peak IT load. If the peak IT load is more than N can support, then system design redundancy will be lost.

Each UPS system with a 2N configuration can have two or three UPS groups. If there are two groups, both of them must be connected to the same load. If there are three groups, then there are three separate loads and each group is connected to two of the loads. The number of modules within each UPS group in a UPS system must be the same in a 2N configuration. Additionally, all UPS modules within a UPS group must have the same derated nameplate rating value (kW).

In the first example, there are two groups with four UPS modules each. In a 2N configuration, one group can stop working and the system will still have the designed redundancy. Therefore, the value for N is four. So, the total IT load cannot exceed the derated nameplate rating of four of the UPS modules.

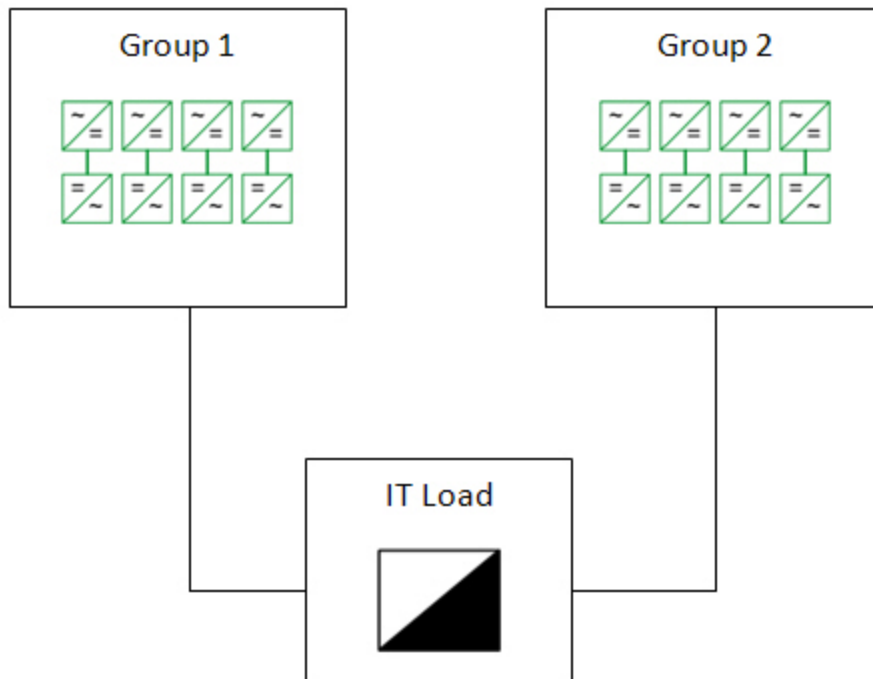

In the second example, there are three groups with four UPS modules each. In a 2N configuration, one group's worth of UPS modules can be rendered inoperative and the system will still have the designed redundancy. Therefore, the value for N is eight. So, the total IT load (for all three IT load groups shown below) cannot exceed the derated nameplate rating of eight of the UPS modules.

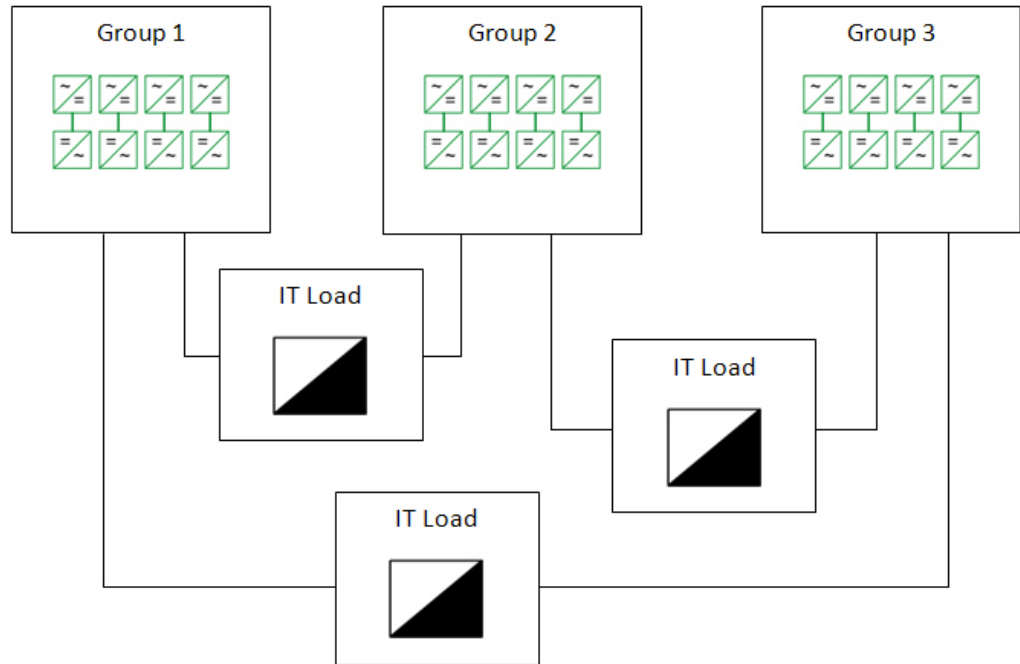

## 2(N+1) Type

The 2(N+1) system configuration is for two or three groups of UPS modules that supply power to two different power supplies in each IT load. The redundancy provided means that an entire group of UPS modules, plus one more module from the remaining groups, can stop working or be taken off-line, and the IT equipment will still be supplied with power. It also means that either one of the two power supplies in an IT load can be rendered inoperative. The load is spread among all UPS modules, but the peak load is such that if an entire group's worth of modules be rendered inoperative, plus one more from each other group, the remaining modules will be able to assume their load. Another way to look at it is, N UPS modules will be able to support the peak IT load. If the peak IT load is more than N can support, then system design redundancy will be lost.

Each UPS system with a 2(N+1) configuration can have two or three UPS groups. If there are two groups, both of them must be connected to the same load. If there are three groups, then there are three separate loads and each group is connected to two of the loads. The number of modules within each UPS group in a UPS system must be the same in a 2(N+1) configuration. Additionally, all UPS modules within a UPS group must have the same derated nameplate rating value (kW).

In the first example, there are two groups with four UPS modules in each group. One group plus one UPS module from the other group can be rendered inoperative, and the system will still have the designed redundancy. Therefore, the value for N is three. So, the total IT load cannot exceed the derated nameplate rating of three of the UPS modules.

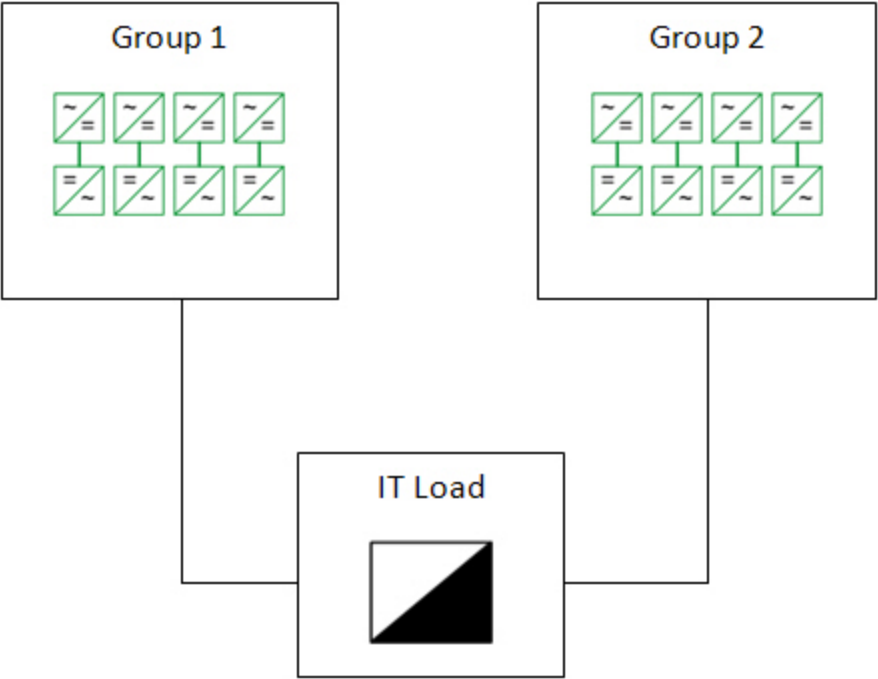

In the second example, there are three groups with four UPS modules in each group. One group plus one module from each of the other two groups can stop working and the system will still have the designed redundancy. Therefore, the value for N is six. So, the total IT load (for all three IT load groups shown below) cannot exceed the derated nameplate rating of six of the UPS modules.

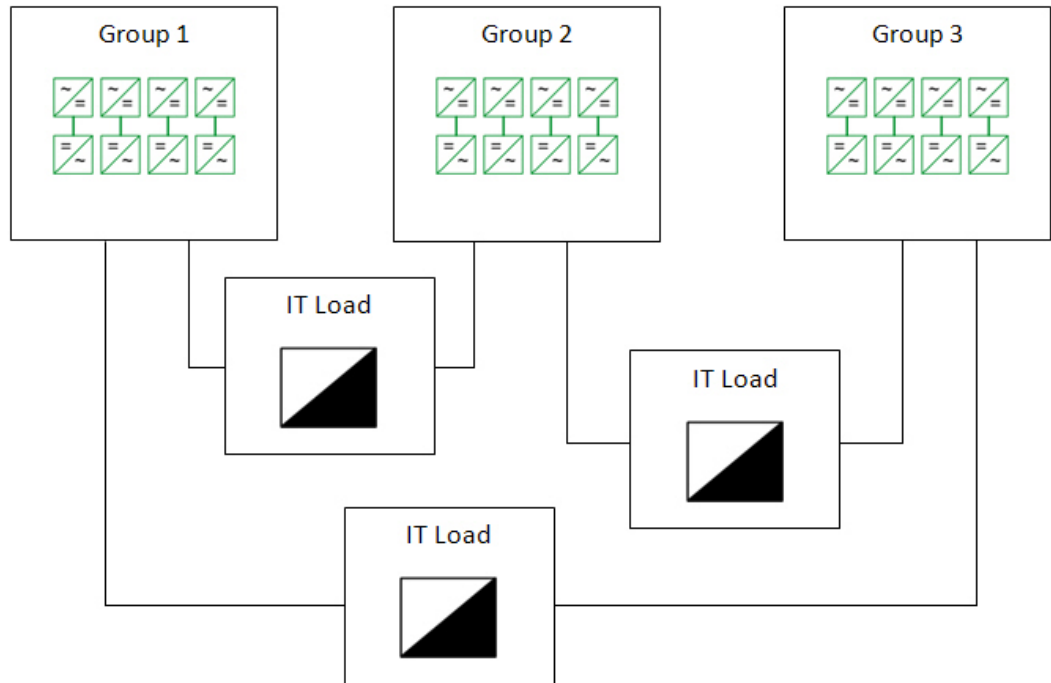

## 2(N+2) Type

The 2(N+2) system configuration is for two or three groups of UPS modules that supply power to two different power supplies in each IT load. The redundancy provided means that an entire group of UPS modules, plus two more modules from the remaining groups, can stop working or be taken off-line and the IT equipment will still be supplied with power. It also means that either one of the two power supplies in an IT load can stop working. The load is spread among all UPS modules, but the peak load is such that, if an entire group stops working, plus two more from the other group, the remaining modules will be able to assume their load. Another way to look at it is, N UPS modules will be able to support the peak IT load. If the peak IT load is more than N can support, then system design redundancy will be lost.

Each UPS system with a 2(N+2) configuration can have two or three UPS groups. If there are two groups, both of them must be connected to the same IT load. If there are three groups, then there are three separate loads and each group is connected to two of the loads. The number of modules within each UPS group must be the same. All UPS modules within a group must have the same derated nameplate rating value (kW).

In the first example, there are two groups with four UPS modules each. One group can be rendered inoperative, plus two more UPS modules from the other group and the system will still have the designed redundancy. Therefore, the value for N is two. The total IT load cannot exceed the derated nameplate rating of two of the UPS modules.

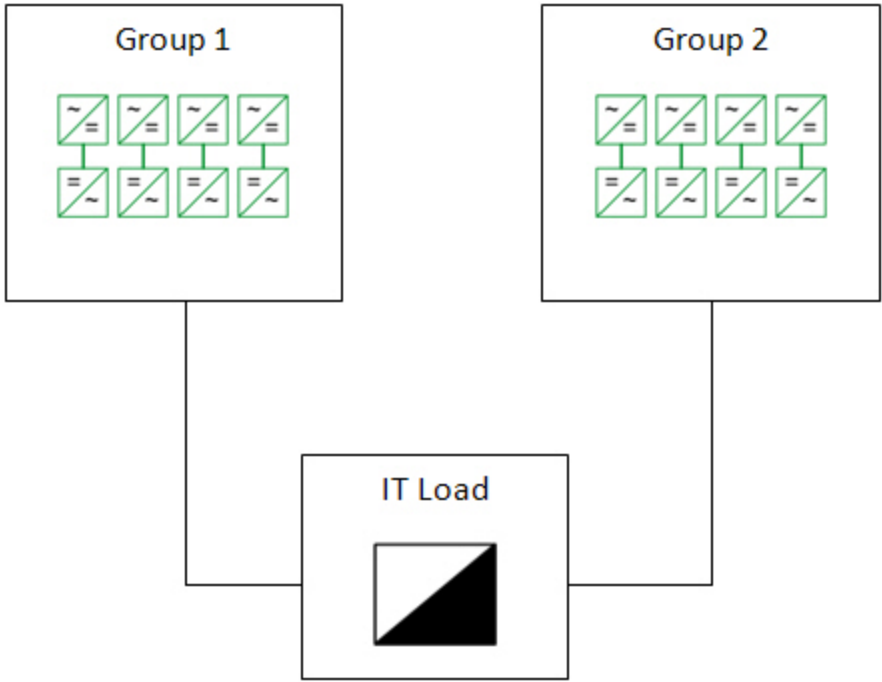

In the second example, there are three groups with four UPS modules each. One group plus two modules from each of the other two groups can stop working, and the system will still have the designed redundancy. Therefore, the value for N is four. So, the total IT load cannot exceed the derated nameplate rating of four of the UPS modules.

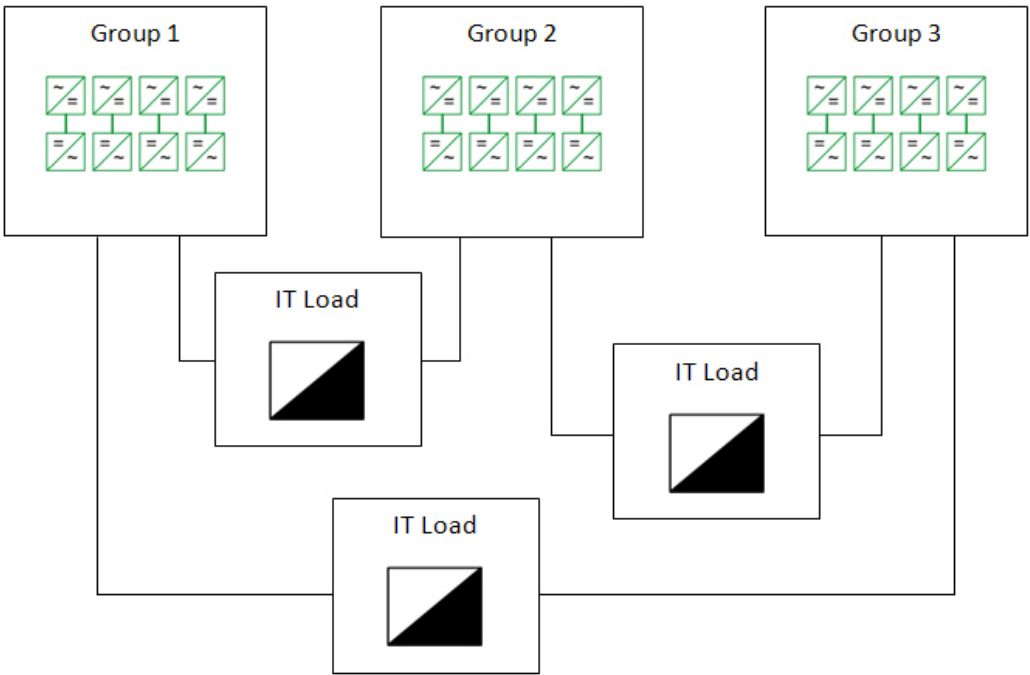

# Uninterrupted Power Supply (UPS) Battery Health Report calculations

The following terms and explanations of various calculations are used in the **UPS Battery Health Report**:

**First Drop Analysis – Minimum Drop Voltage (V), Maximum Drop Voltage (V) and Difference (%)**: The voltage drop minimum, maximum and percentage difference values are shown in the Drop Analysis table section. To calculate these values, a valid waveform voltage drop must be found first by sampling the waveform data.

A valid voltage drop is defined as the first waveform section of size  $n$ , where the relative minimum and maximum voltage values have a percentage difference  $d$ . In addition, the next sample  $n+1$  must be greater in value than the minimum voltage, to ensure that the lowest value has been found in the voltage drop.

The sampling section size  $n$  and the percentage difference  $d$  are determined by the user-defined report parameters Waveform Drop Sample Size and Waveform Drop Percentage, respectively.

After the voltage drop has been found, the Minimum Voltage and Maximum Voltage are simply the min and max values in that drop samples, and the Difference is the percentage of the maximum voltage over the minimum voltage. For example:

$$\text{Minimum Drop Voltage} = \text{Min}(ws1 \leq \text{WaveformValues} \leq wsN)$$

$$\text{Maximum Drop Voltage} = \text{Max}(ws1 \leq \text{WaveformValues} \leq wsN)$$

$ws1$  is the first point in the sample and  $wsN$  is the last point in the sample

$$\text{Difference (\%)} = [(\text{Maximum Drop Voltage} - \text{Minimum Drop Voltage}) / \text{Maximum Drop Voltage}]$$

**Recovery Analysis – Target Recovery Voltage (V), Actual Recovery Voltage (V) and Recovery Time (ms)**:

**Target Recovery Voltage (V)**: This value is calculated for the reference waveform only. This is calculated as follows:

$$\text{Target Recovery Voltage (V)} = [\text{Recovery Voltage} * \text{Recovery Value Multiplier}]$$

$$\text{Where Recovery Voltage} = \text{Average}(w1 \leq \text{WaveformValues} < wN)$$

$w1$  is the very first point in the waveform and  $wN$  is the lowest point in the waveform voltage drop and Recovery Value Multiplier is a user-defined value in the report prerequisite page

**Actual Recovery Voltage (V)**: The first point in the reference and comparison waveforms that occurs after the voltage drop, that is equal or greater than the Target Recovery Voltage value.

**Recovery Time (ms)**: This is the time elapsed from the Minimum Voltage Drop time and the Actual Recovery Voltage time, expressed in milliseconds.

## Additional Calculations

**Voltage Threshold:** This is the red horizontal area that is highlighted in the waveform drop chart. It represents a nominal voltage value, therefore there are no calculations for the Voltage Threshold.

For example, if the user sets the Voltage Threshold to 50V, then a red line will be drawn at 50v (based on the Y-axis) and the area below the red line appears shaded in red .





Power Monitoring Expert 8.1 Application Modules  
Configuration Guide

Schneider Electric  
35 rue Joseph Monier  
92500 Rueil Malmaison – France  
[www.schneider-electric.com](http://www.schneider-electric.com)

As standards, specifications, and designs change from time to time, please ask for confirmation of the information given in this publication.

© 2016 Schneider Electric. All Rights Reserved.

7EN42-0131-00 04/2016