

# Power-Zone<sup>®</sup> 4

## Low Voltage, Metal-Enclosed Drawout Switchgear with Masterpact<sup>®</sup> Low Voltage Power Circuit Breakers Class 6037

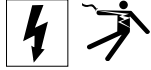
Instruction Bulletin

80298-002-06

Retain for future use.



## HAZARD CATEGORIES AND SPECIAL SYMBOLS



Read these instructions carefully and look at the equipment to become familiar with the device before trying to install, operate, service or maintain it. The following special messages may appear throughout this bulletin or on the equipment to warn of potential hazards or to call attention to information that clarifies or simplifies a procedure.

The addition of either symbol to a “Danger” or “Warning” safety label indicates that an electrical hazard exists which will result in personal injury if the instructions are not followed.

This is the safety alert symbol. It is used to alert you to potential personal injury hazards. Obey all safety messages that follow this symbol to avoid possible injury or death.

### **DANGER**

**DANGER** indicates an imminently hazardous situation which, if not avoided, **will result in** death or serious injury.

### **WARNING**

**WARNING** indicates a potentially hazardous situation which, if not avoided, **can result in** death or serious injury.

### **CAUTION**

**CAUTION** indicates a potentially hazardous situation which, if not avoided, **can result in** minor or moderate injury.

### **CAUTION**

**CAUTION**, used without the safety alert symbol, indicates a potentially hazardous situation which, if not avoided, **can result in** property damage.

**NOTE:** Provides additional information to clarify or simplify a procedure.

## PLEASE NOTE

Electrical equipment should be installed, operated, serviced, and maintained only by qualified personnel. No responsibility is assumed by Schneider Electric for any consequences arising out of the use of this material.

# TABLE OF CONTENTS

Section 1—Introduction .....	7
General Description .....	7
Section 2—Safety Precautions .....	9
Section 3—Receiving, Handling, and Storage .....	10
Receiving .....	10
Identification .....	10
Handling .....	10
Handling with Lifting Straps .....	10
Handling without Lifting Straps .....	11
Circuit Breakers .....	12
Circuit Breaker Lifter Bars (if furnished) .....	12
Traveling Lifter (if furnished) .....	13
Floor Crane (if furnished) .....	13
Storage .....	13
Section 4—Installation .....	14
Assemble the Shipping Sections .....	14
Prepare the Site .....	14
Prepare the Foundation .....	14
Position the Switchgear .....	15
Align the Vertical Sections .....	15
Join the Shipping Splits .....	15
Join the Wiring Compartments .....	16
Anchor the Switchgear (Non-seismic) .....	17
Seismic Certification .....	18
Responsibility for Mitigation of Seismic Damage .....	18
Anchor the Switchgear (Seismic) .....	19
Securing Structures to Floor—Seismic Hazard Designated Locations .....	20
Connect the Bus .....	20
Prepare the Bus Joints .....	20
Splice the Ground Bus .....	21
Splice the Neutral Bus .....	22
Splice the Main Through Bus .....	24
Grounding and Bonding .....	26
Service Equipment (Solidly Grounded Systems) .....	26
Service Equipment (Ungrounded Systems) .....	27
Not Service Equipment .....	27
High-Impedance Grounded Neutral Systems .....	27
Connect the Power Cables, Controls, and Wiring .....	27
Connect the Power Cables .....	27
Conductor Restraint for Short-Circuit Current Rating (SCCR) .....	29
Connect the Controls and Wiring .....	30
Mount the Flex Connectors .....	31
Install the Traveling Lifter .....	33
Align the Sections and Rails .....	34
Rail Alignment Troubleshooting Steps .....	35
Install the Carriage Assembly .....	35
Install the Winch Mechanism .....	37
Inspect and Test Before Operation .....	39
Assemble the Circuit Breaker Lifter Bars .....	41
Prepare and Install the Circuit Breakers .....	42
Lift and Move the Circuit Breakers .....	42
Switchgear Inspection and Testing Before Operation .....	44
Check the Power Circuit Connections .....	44
Check the External Equipment .....	44
Check the Auxiliary Equipment .....	44
Check the Equipment Ground-Fault Systems .....	45
Conduct the Electrical Insulation Resistance Test .....	45

Section 5—Pre-Energizing Checkout Procedure .....	46
Section 6—Energizing the Switchgear .....	47
Section 7—Maintaining the Switchgear .....	48
Switchgear Inspection Guidelines .....	48
Ideal Operating Conditions .....	48
Normal Operating Conditions.....	49
Harsh Operating Conditions.....	49
General Inspection and Cleaning .....	50
Bus Bar Joints, Lug Terminations, and Insulating Materials .....	50
Traveling Lifter Inspection and Maintenance Procedures .....	51
Lubrication .....	51
Inspection and Maintenance .....	51
Circuit Breaker Inspection Schedule .....	51
Section 8—Adverse Circumstances .....	52
Inspection Following a Short Circuit .....	52
Clean-up Following a Short Circuit .....	52
Water-Soaked Switchgear .....	52
Water-Sprayed or Splashed Switchgear (Clean Water Only) .....	52
Inspection and Clean-up of Clean Water Sprayed or Splashed Switchgear .....	53
Section 9—Switchgear Insulation Resistance Chart .....	54
Section 10—Maintenance Log .....	55

# LIST OF FIGURES

Figure 1:	Typical Power-Zone 4 Switchgear .....	7
Figure 2:	Rail-Mounted Traveling Lifter .....	8
Figure 3:	Lifting with an Overhead Crane, Lifting Straps, and Cables or Chains .....	11
Figure 4:	Handling Instruction Label, Switchgear without Lifting Straps .....	11
Figure 5:	Switchgear in Sling Rigging .....	12
Figure 6:	Forklift Safety Strap .....	12
Figure 7:	Final Positioning of the Switchgear (Side View) .....	15
Figure 8:	Joining the Shipping Splits (Side View) .....	15
Figure 9:	Removing the Wiring Compartment Covers .....	16
Figure 10:	Joining the Wiring Compartments .....	16
Figure 11:	Anchoring Using Base Channels .....	17
Figure 12:	Typical Floor Plan (Bottom View)—Non-Seismic .....	17
Figure 13:	Typical Floor Plan (Side View)—Non-Seismic .....	17
Figure 14:	Typical Floor Plan (Bottom View)—Seismic .....	20
Figure 15:	Typical Floor Plan (Side View)—Seismic .....	20
Figure 16:	Splicing the Ground Bus .....	21
Figure 17:	Ground Bus Connected .....	21
Figure 18:	Installing Conical Washers .....	21
Figure 19:	Splicing the Neutral Bus .....	22
Figure 20:	Removing Rear Barriers (If Provided) .....	22
Figure 21:	Neutral Bus Laminations .....	23
Figure 22:	Installing Conical Washers .....	23
Figure 23:	Typical Main Through Bus Splice Pads .....	24
Figure 24:	Splicing the Main Through Bus .....	24
Figure 25:	Typical Main Through Bus (A, B, and C Phases) .....	25
Figure 26:	Installing Conical Washers .....	25
Figure 27:	Main Bonding Jumper and Grounding Electrode Conductor Connector (Grounded Systems) .....	26
Figure 28:	Main Bonding Jumper and Grounding Electrode Conductor Connector (Ungrounded Systems) .....	27
Figure 29:	Connecting the Cables .....	28
Figure 30:	Wrapping Conductors .....	29
Figure 31:	Wrapping the Space Between Conductors .....	29
Figure 32:	Finish Wrapping the Space Between Conductors .....	30
Figure 33:	Tying Rope Ends Together .....	30
Figure 34:	Removing the Wiring Compartment Covers .....	30
Figure 35:	Typical Flex Connections .....	31
Figure 36:	Typical Transformer Connection on Right Side of Switchgear .....	32
Figure 37:	Typical Traveling Lifter Assembly .....	33
Figure 38:	Aligning the Vertical Sections .....	34
Figure 39:	Aligning the Front and Rear Rails .....	35
Figure 40:	Carriage Assembly (Front and Side View) .....	36
Figure 41:	Installing the Carriage Assembly .....	36
Figure 42:	Removing the Front Carriage Bracket .....	37
Figure 43:	Winch Mechanism (Front View) .....	38
Figure 44:	Installing the Winch Mechanism .....	38
Figure 45:	Installing the Front Carriage Bracket .....	38
Figure 46:	Visually Inspecting the Traveling Lifter .....	39
Figure 47:	Testing the Carriage Assembly .....	40
Figure 48:	Testing the Winch Mechanism .....	40
Figure 49:	T-Frame Circuit Breaker Lifter Bar .....	41
Figure 50:	W-Frame Circuit Breaker Lifter Bar .....	41
Figure 51:	Y-Frame Circuit Breaker Lifter Bar .....	41
Figure 52:	Attaching the Lifter Bar to the Circuit Breaker .....	42
Figure 53:	Attaching the T-Frame Lifter Bar to the Circuit Breaker .....	43
Figure 54:	Lifting and Moving the Circuit Breaker .....	43

ENGLISH

## LIST OF TABLES

Table 1:	Number of Laminations Required Per Phase .....	25
Table 2:	Incoming, Branch, Neutral and Ground Lugs .....	26
Table 3:	Multiple Conductor Neutral and/or Ground Bus.....	26
Table 4:	Conductor Restraint Requirements.....	29
Table 5:	Transformer Flex Connections .....	32
Table 6:	Circuit Breaker Lifter Bar Assembly.....	41

## Section 1—Introduction

This manual contains instructions for the proper installation, operation, and maintenance of Square D® brand Power-Zone® 4 switchgear equipment from Schneider Electric.

The purchaser's engineering, installation, and operating staff supervisors should familiarize themselves with this manual and become acquainted with the appearance and characteristics of each piece of equipment mounted or contained in the switchgear.

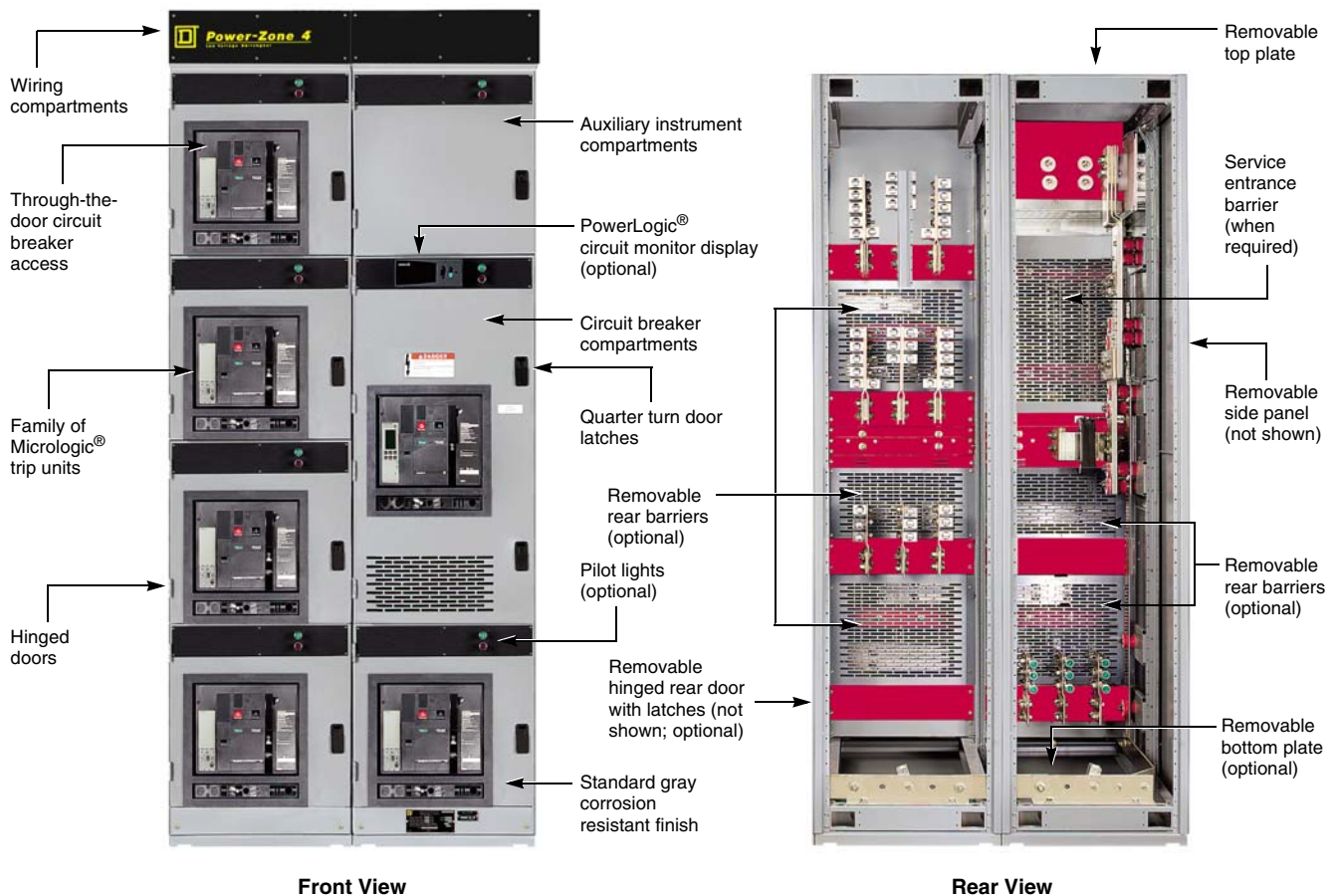
These instructions and procedures apply to Square D brand Power-Zone 4 switchgear installations. When special features or non-standard components are incorporated in the switchgear, detailed instructions for these components are included in the instruction material holder.

## General Description

Square D brand Power-Zone 4 switchgear is manufactured with rugged 12-gauge steel and electrodeposition coated with gray paint to stand up to normal industrial environments. The switchgear is compartmentally designed to enclose all electrical parts. Power-Zone 4 switchgear is Underwriters Laboratories® (UL®) Listed to UL 1558 and is designed, manufactured, and tested in accordance with ANSI/IEEE C37.20.1 and C37.51.

A typical assembly is shown in Figure 1.

Figure 1: Typical Power-Zone 4 Switchgear

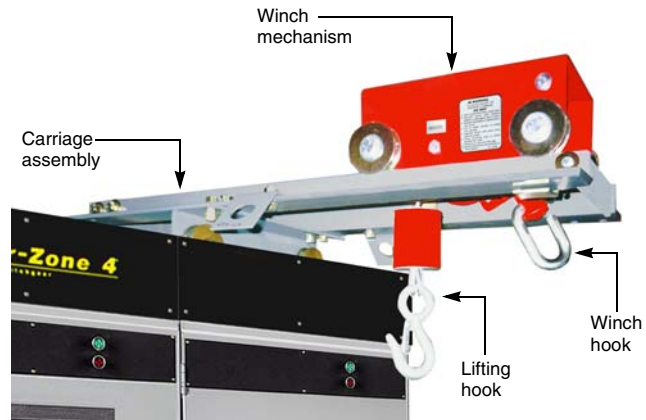


Power-Zone 4 switchgear with Masterpact® circuit breakers provide overload, short-circuit, and equipment ground-fault protection for circuits up to 600 volts. The switchgear is a stationary structure, which includes one or more free-standing vertical sections mechanically and electrically joined to make a single coordinated installation.

Each vertical section consists of three separate areas: front compartment (including secondary wireways), bus compartment, and rear cable compartment. One or more of the sections within the front area can be used as an auxiliary instrument compartment containing potential transformers, meters, relays, and control devices.

When specified, a rail-mounted traveling lifter assembly is included with indoor Power-Zone 4 switchgear. The lifting device is available in both manual crank and electrical operation. The manual lifting device is available on enclosures without drip hoods and is capable of lifting Masterpact circuit breakers into and out of any compartment. The circuit breaker is raised or lowered by cranking the winch mechanism.

**Figure 2: Rail-Mounted Traveling Lifter**



Extra features and special control options are often incorporated when specified by the purchaser's order. The special features are shown on the drawings and diagrams for the specific switchgear assembly. Instructions for relays, instruments, control switches, and circuit breakers are included in the order documents shipped with the switchgear.

In addition to this manual, other printed documentation is supplied for the switchgear components. Read and understand all applicable documentation before beginning the installation of the switchgear.

## Section 2—Safety Precautions

This section contains important safety precautions that must be followed before attempting to lift, move, install, use, or maintain Power-Zone 4 switchgear and associated components.

### **⚠ DANGER**

#### **HAZARD OF ELECTRIC SHOCK, EXPLOSION, OR ARC FLASH**

- Apply appropriate personal protective equipment (PPE) and follow safe electrical work practices. See NFPA 70E.
- This equipment must be installed and serviced only by qualified electrical personnel.
- Perform such work only after reading and understanding all of the instructions contained in this bulletin.
- Turn off all power supplying this equipment before working on or inside equipment.
- Always use a properly rated voltage sensing device to confirm power is off.
- Before performing visual inspections, tests, or maintenance on this equipment, disconnect all sources of electric power. Assume all circuits are live until they are completely de-energized, tested, and tagged. Pay particular attention to the design of the power system. Consider all sources of power, including the possibility of backfeeding.
- Always practice lock-out/tag-out procedures according to OSHA requirements.
- Circuit breaker and switch contacts must be open and all springs discharged before performing maintenance work, disconnection, or removal of a circuit breaker.
- Conduct electrical testing to confirm no short-circuits were created during installation, maintenance, or inspection.
- Never insert a circuit breaker into a circuit breaker compartment that is not complete and functional.
- Be aware of potential hazards; wear personal protective equipment, and take adequate safety precautions.
- Carefully inspect your work area, and remove any tools and objects left inside the equipment.
- Replace all devices, doors, and covers before turning on power to this equipment.
- All instructions in this manual are written with the assumption that the customer has taken these measures before performing maintenance or testing.

**Failure to follow these instructions will result in death or serious injury.**

### **⚠ DANGER**

#### **HAZARD OF ELECTRIC SHOCK, EXPLOSION, OR ARC FLASH**

When the insulated bus feature is provided, all safety mechanisms, procedures, and practices as specified in this manual shall still apply and must be followed.

**Failure to follow this instruction will result in death or serious injury.**

## Section 3—Receiving, Handling, and Storage

Power-Zone 4 switchgear is shipped assembled in one or several shipping sections, depending on the size of the lineup and the handling facilities at the installation site.

Indoor shipping sections are mounted on wooden skids and enclosed in a covering to protect them from atmospheric conditions.

For instructions regarding the various components, refer to the manual associated with each product.

### Receiving

Upon receipt, check the packing list against the equipment received to ensure the order and shipment are complete. Also upon receipt, immediately inspect switchgear sections for any damage that may have occurred in transit. If damage is found or suspected, file a claim with the carrier immediately, and notify Square D Services at 1-888-778-2733.

### Identification

The rating nameplate is on the front cover of each structure. Included on the nameplate is the following information:

1. Factory order number
2. Rated maximum voltage
3. Frequency
4. Bus current ratings
5. Short-circuit current ratings

**NOTE:** All ratings are the maximum limits of the equipment.

### Handling

Ensure that proper equipment, such as an overhead crane, is available at the installation site to handle the switchgear. This equipment will help avoid injury to personnel and damage to the switchgear.

<b>CAUTION</b>
<b>EQUIPMENT HANDLING HAZARD</b> Do not lay the equipment on its back, front, or sides without specific instructions from Schneider Electric. <b>Failure to follow this instruction can result in equipment damage.</b>

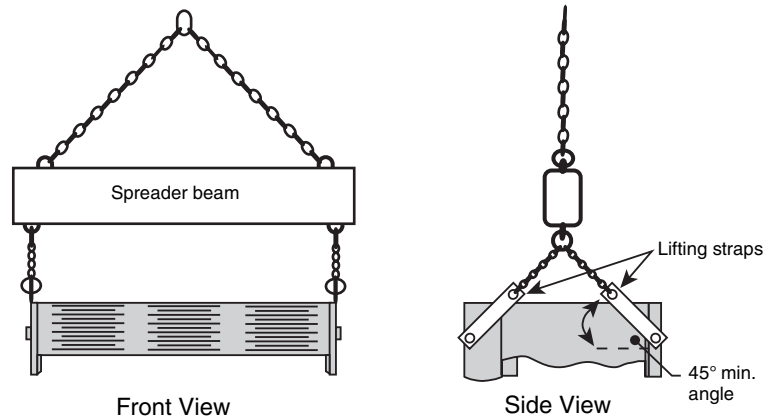
For ease of handling by a crane, all shipping sections are equipped with lifting straps at each corner of the section. This equipment is shipped up to a maximum of 88 inches (2,235 mm) wide. The lifting strap has a 1.38-inch (35 mm) diameter hole for acceptance of crane hooks as shown in Figure 3 on page 11. Use a suitable spreader beam to maintain the integrity of the lifting straps. Variations in the center of gravity may cause the equipment to tilt to one side or the other.

Schneider Electric recommends using an overhead crane, lifting straps, and cables or chains to handle the switchgear. This method and alternative handling methods are discussed in this section.

### Handling with Lifting Straps

Schneider Electric provides lifting straps as standard equipment for switchgear shipping sections that are 88 inches (2,235 mm) wide or less. Instruction labels on each shipping section include drawings and written instructions outlining the proper use of the lifting straps (Figure 3 on page 11). Use rigid spreaders or a spanner bar to provide vertical lift on the lifting straps. This will help to avoid damaging the frame or finish.

**Figure 3: Lifting with an Overhead Crane, Lifting Straps, and Cables or Chains**



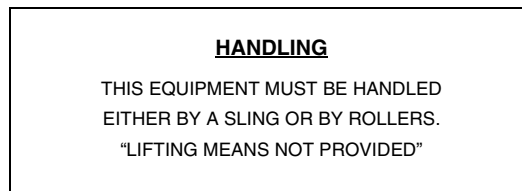
Follow these instructions to handle the switchgear.

1. Use load-rated cables or chains with safety hooks or shackles. Do not pass cables or chains through holes in lifting straps.
2. Use a load-rated spreader beam to prevent structure damage. Rig so that the minimum angle between the lifting cables or chains and equipment top is 45 degrees.

Handling without Lifting Straps

Lifting straps are not furnished on shipping sections longer than 88 inches (2,235 mm) or on rainproof switchgear. Rollers, slings, or other means must be used to handle the shipping section. The handling label (Figure 4) is affixed to each of these sections.

**Figure 4: Handling Instruction Label, Switchgear without Lifting Straps**



When elevating a shipping section not equipped with lifting straps, an overhead crane equipped with either of the following may be used:

- A chain coupled to a sling rigging
- A wire cable with safety hooks and shackles

Wrap the sling completely around the switchgear and shipping stringers (Figure 5 on page 12).

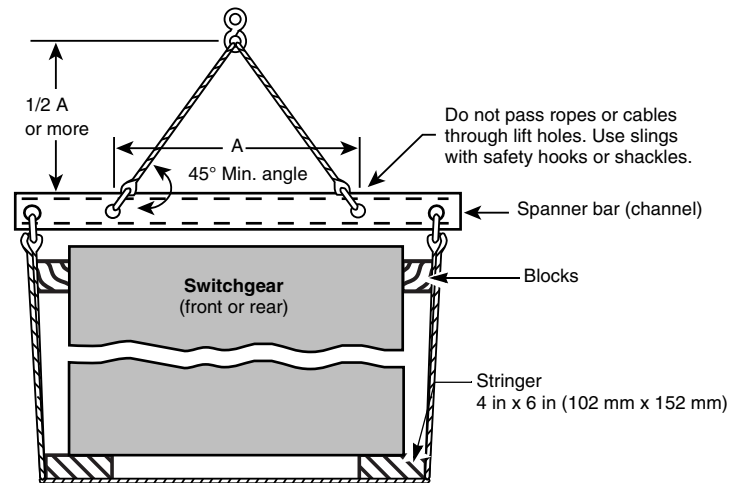
## ⚠ WARNING

### TOP HEAVY LOAD

Stabilize the shipping section to reduce the possibility of tipping.

**Failure to follow this instruction can result in death or serious injury.**

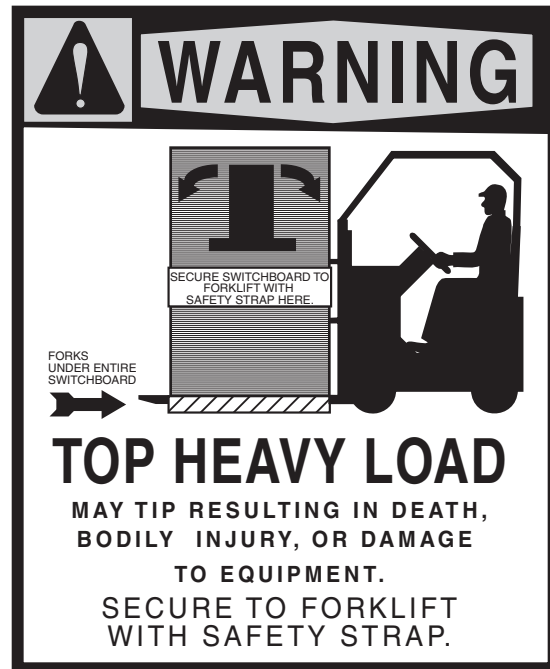
Figure 5: Switchgear in Sling Rigging



A forklift is an alternative method of handling the switchgear.

**NOTE:** Always check the fork lengths to ensure that the forks extend under the entire switchgear. Carefully balance the load and always use a safety strap when handling or moving a switchgear with a forklift (Figure 6).

Figure 6: Forklift Safety Strap



Circuit Breakers

Use care when uncrating, rolling, hoisting, or handling Masterpact circuit breakers. (See page 42 for additional instructions.) Use care not to remove or damage the warning labels on the circuit breaker.

Circuit Breaker Lifter Bars (if furnished)

Use care when uncrating or handling the circuit breaker lifter bars.

Traveling Lifter (if furnished)

Use care when uncrating, rolling, hoisting, or handling the traveling lifter assembly. The traveling lifter assembly weighs 65 lb (29 kg). Use suitable mechanical aids when handling the assembly.

See page 33 for further instructions. Use care not to remove or damage the warning labels on the traveling lifter assembly.

Floor Crane (if furnished)

Use care when unpacking and handling the optional floor crane. Refer to the manufacturer's instructions for proper usage and handling.

## Storage

If the Power-Zone 4 switchgear assembly is to be stored before being placed into service, perform the steps listed below.

1. Unpack the equipment to check for completeness and condition.
2. Reseal the equipment in its packing for protection until installation.

When storing the equipment:

- Keep the equipment in a clean, dry place that is free from corrosive elements and mechanical abuse.  
**NOTE:** Indoor equipment should be stored in an atmospherically controlled building until installation. Keep the equipment clean and dry, with a humidity less than 80% and temperature between 32 °F (0 °C) and 104 °F (40 °C). Avoid moisture, changes in temperature, cement dust, and corrosive atmospheres.
- Covering the equipment with a tarpaulin may be necessary to protect it from contaminants or moisture.
- Do not store indoor units outdoors.
- If it is necessary to store the equipment outdoors, make special arrangements to keep the equipment clean, dry, and within the temperature and humidity limits stated above.
  - It may be necessary to cover the equipment and install temporary heating units.
  - Place the shipping sections on level surfaces for storage to maintain structural integrity.
- In areas of high humidity, such as installations near oceans or rivers, monitor the switchgear equipment closely.
  - If necessary, use additional heat to keep the switchgear dry.
  - Contact Square D Services at 1-888-778-2733 if the internal heaters are not adequate for your location.
- If the optional traveling lifter assembly is to be stored, do not remove it from its packing until installation.
- If optional internal heaters are supplied with the switchgear, connect them to an external power source. Energize the heaters inside the switchgear, or add heat from a separate source, such as a light bulb or blower. Use a minimum of 250 watts of heat per vertical section to keep the equipment dry during storage.

## Section 4—Installation

### Assemble the Shipping Sections

Before installing Power-Zone 4 switchgear, read and understand:

- All precautions in this manual.
- All manuals for associated components.
- All drawings and diagrams included with the equipment.

When correctly installed, indoor switchgear conforms to the following requirements.

- ❑ Front panels form a straight, true line; and when transformers and/or other gear are included, the front panels line up or form parallel lines.
- ❑ Units are spaced correctly from center-to-center and perpendicular to the mounting surface.
- ❑ The switchgear is fastened securely to the floor channels or base pad.
- ❑ The shipping sections are bolted together securely.
- ❑ Bus and control wiring connections are connected properly.

### Prepare the Site

Before positioning the equipment, check these items to ensure that the site is ready for final installation.

- ❑ Compare the site plans and specifications with the equipment drawings to be sure no discrepancies exist.
- ❑ Check the site to confirm switchgear will fit properly.
- ❑ Provide area ventilation at all times to maintain the ambient temperature around the equipment between 32 °F (0 °C) and 104 °F (40 °C).
- ❑ Provide adequate permanent lighting and convenience outlets near the equipment.
- ❑ Route sewer, water, and steam lines away from the equipment.
- ❑ Provide floor drains near the equipment.
- ❑ When installing the equipment, consider the aisle space required at the front and rear of the equipment, as well as space at the ends of the lineup.

**NOTE:** Required minimum clearances around switchgear are given in Article 110.26 of the National Electrical Code® (NEC®). These clearances are only a minimum. Additional space may be required for insertion and withdrawal of circuit breakers and to transfer to other compartments with a hoist or floor crane.

### Prepare the Foundation

- ❑ Confirm that the floor or foundation is strong enough to support the equipment without distortion or sagging.

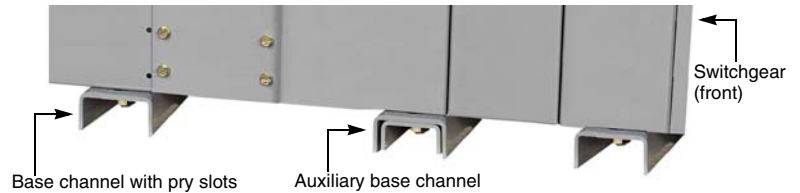
**NOTE:** Refer to the shipping documents for actual weights of the equipment.

- ❑ Confirm that the concrete and channels are level left-to-right and front-to-rear within 1/8-inch per square yard (3 mm per square meter).
- ❑ Install equipment on a smooth, level base to keep tolerances and adjustments to a minimum.
- ❑ Confirm that the steel channels are level with the finished base and that the surrounding base gently slopes toward a drain.

### Position the Switchgear

1. Pry the switchgear by inserting a crowbar or pry bar into a base channel slot.
2. Carefully move the switchgear into position until the front panels form a straight, true line.
3. Confirm that the vertical section front(s) line up or form parallel lines.

**Figure 7: Final Positioning of the Switchgear (Side View)**



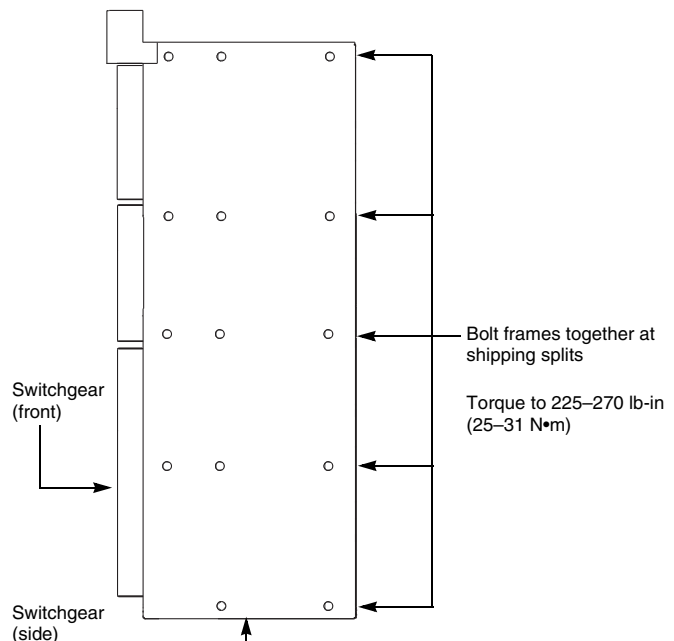
### Align the Vertical Sections

1. Establish a base line a few inches in front of the switchgear and parallel to the installation location.
2. Equalize the distances from the front of the switchgear to the base line, making the face of the section parallel to the base line.
3. After the first shipping section has been placed, move the second section into position and similarly check it.
4. Fasten the vertical sections together.
5. Repeat steps 3 and 4 until the installation is complete.
6. Check the traveling lifter front and rear rails for proper alignment. If the rails are misaligned, adjust for front and rear alignment of equipment. See “Align the Sections and Rails” on page 34.

### Join the Shipping Splits

1. Obtain the 3/8-16-inch shipping split hardware located inside the equipment.
2. Bolt the frames together (Figure 8) with the shipping split hardware. Torque the hardware to 225–270 lb-in (25–31 N•m).

**Figure 8: Joining the Shipping Splits (Side View)**



Join the Wiring Compartments

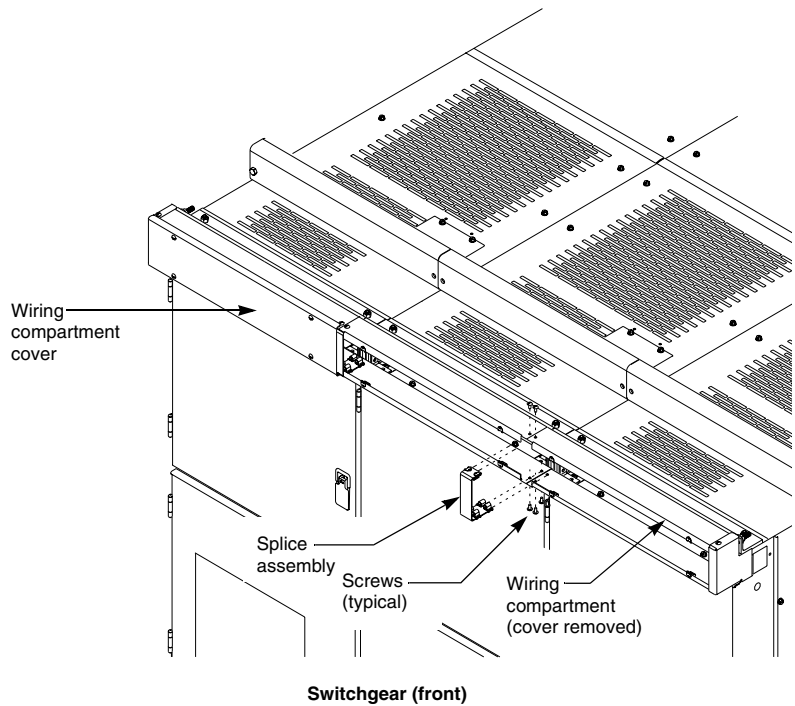
1. After the frames of the shipping splits have been bolted together, remove the wiring compartment covers (Figure 9) at the split.

**Figure 9: Removing the Wiring Compartment Covers**



2. Remove the splice assembly (Figure 10) in the wiring compartments toward the left of the split.

**Figure 10: Joining the Wiring Compartments**



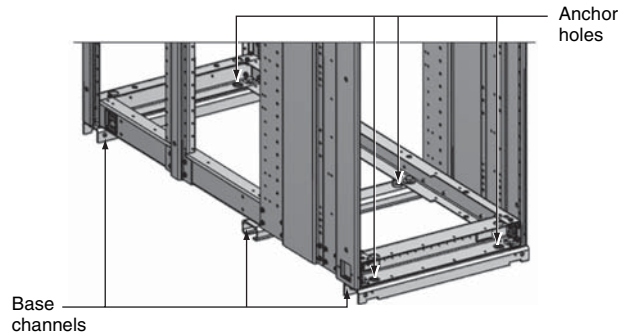
3. Remove the screws from the splice assembly. Retain the screws for reuse.
4. Install the splice assembly (Figure 10) using the screws removed in step 3.

Anchor the Switchgear (Non-seismic)

Although sections are freestanding, a hard bump or shifting movement can result in damage to the splice joints between sections and conduit hubs connected to the sections. Therefore, anchor the base channels to the floor. Formed base channels run the width of the shipping section. The channels have 3/4-inch (19 mm) diameter holes for fastening the section to the floor.

1. Anchor each section to the floor (Figure 11) with four 1/2-inch (13 mm) Grade 2 (minimum) bolts, flat washers, and anchors.

Figure 11: Anchoring Using Base Channels



2. After all shipping sections are joined together, and the entire structure is bolted to the floor, install the incoming service conductors and load side cables. Refer to the floor plan examples in Figures 12 and 13.

Figure 12: Typical Floor Plan (Bottom View)—Non-Seismic

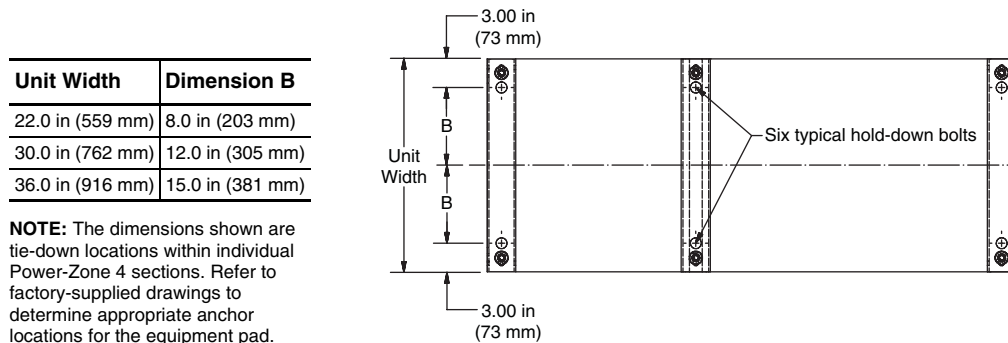
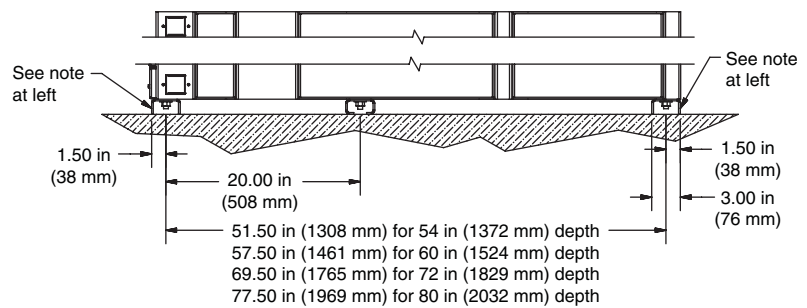


Figure 13: Typical Floor Plan (Side View)—Non-Seismic

**NOTE:** Concrete and channels should be level left to right and front to rear within 1/8-inch per square yard (3 mm per square meter).



## Seismic Certification

Power-Zone 4 switchgear that are seismically certified have been qualified to the site-specific seismic requirements of the listed model building codes and/or standards. Optional construction features may be required, depending on the location of the installation and the particular code and/or standard of interest. Seismic certificates of compliance and equipment labels are provided with all seismically certified switchgear. To maintain the validity of this certification, the installation instructions provided in this section must be followed.

### Responsibility for Mitigation of Seismic Damage

For the purposes of the model building codes, Power-Zone 4 switchgear are considered nonstructural building components. Equipment capacity was determined from tri-axial seismic shake table test results as defined in the International Code Counsel Evaluation Service (ICC ES) Acceptance Criteria for Seismic Qualification Testing of Nonstructural Components (AC156).

Unless otherwise indicated, an equipment importance factor of 1.5 (IP = 1.5) was used, indicating that equipment functionality was verified before and after shaker table seismic simulation testing. This importance factor is indicative of critical facilities where maximizing the probability of post event functionality is a priority.

AC156 is published by the ICC ES and has been recognized by the Building Seismic Safety Council (BSSC) as an appropriate methodology in the 2003 National Earthquake Hazard Reduction Program (NEHRP) commentary. The National Institute of Building Sciences established the BSSC in 1979 to develop and promote regulatory provisions for earthquake risk mitigation at the national level.

Incoming and outgoing cable and conduit must also be considered as related but independent systems. They must be designed and restrained to withstand the forces generated by the seismic event without increasing the load transferred to the equipment. For applications where seismic hazard exists, bottom entry and/or exit of cable and conduit is preferred.

A lateral restraint system is also required in situations where horizontal motion at the top of the Power-Zone 4 switchgear is not desirable (such as applications where top entry and/or exit of conduit are used). This system must be capable of transferring the loads created to the load-bearing path of the building structural system.

Seismic qualification of nonstructural components by Schneider Electric is just one link in the total chain of responsibility required to maximize the probability that the equipment will be intact and functional after a seismic event. During a seismic event, the equipment must be able to transfer the loads that are created through the mounting pad and anchorage to the load-bearing path of the building structural system.

The structural civil engineer or design engineer of record is responsible for detailing the equipment connection and anchorage requirements (including the lateral restraint system if appropriate) for the given installation. The installer and manufacturers of the anchorage and lateral restraint system are responsible for assuring that the mounting requirements are met. Schneider Electric is not responsible for the specification and performance of these systems.

### Anchor the Switchgear (Seismic)

Formed base channels run the width of the shipping section. The channels have 3/4-inch (19 mm) diameter holes for fastening the section to the floor. Use all six mounts to anchor the switchgear to the floor properly.

During an earthquake, the top of the switchgear can move in any direction. Any top incoming cables must accommodate this motion. The switchgear enclosure (particularly the top) should not be used to mount exterior equipment.

#### *When anchoring to a concrete pad:*

- Use 1/2-inch (13 mm) diameter Grade 5 (minimum) concrete anchor bolts or sleeve anchors suitable for installation of electrical equipment.
  - Use a 1/2-inch (13 mm) hardened washer (approximately 1.5-inch (38 mm) OD) and lock washer under the head of each bolt or anchor nut, and torque to the value specified by the manufacturer of the anchor to develop the full strength of the anchor.
  - Stud anchors, sleeve anchors, or concrete anchor bolts are recommended (follow manufacturer's instructions for recommended hole size). Do not use expansion shields, such as "lag screw shields". The concrete pad should be constructed from 3000 psi (minimum) strength concrete mix.
1. Anchor each section to the concrete pad with six 1/2-inch (13 mm) Grade 5 (minimum) bolts, hardened washers, and anchors.
  2. After all shipping sections are joined together, and the entire structure is bolted to the concrete pad, install the incoming service conductors and load side cables. Refer to the floor plan examples in Figures 14 and 15 on page 20.

#### *When anchoring sections to a floor other than concrete:*

- Use six 1/2-inch (13 mm) Grade 5 (minimum) bolts or studs through the holes in the base channels.
  - Secure bolts or studs to the floor with anchors or other means to achieve the full strength of the seismic restraint system.
  - Use a 1/2-inch (13 mm) hardened washer (approximately 1.5-inch (38 mm) OD) and lock washer under the head of each bolt or anchor nut, and torque to the value specified by the manufacturer of the anchor to develop the full strength of the anchor.
1. Anchor each section to the floor with six 1/2-inch (13 mm) Grade 5 (minimum) bolts, hardened washers, and anchors.
  2. After all shipping sections are joined together, and the entire structure is bolted to the floor, install the incoming service conductors and load side cables. Refer to the floor plan examples in Figures 14 and 15 on page 20.

Securing Structures to Floor—Seismic Hazard <sup>1</sup>  
Designated Locations

Each section must be anchored to the load-bearing path of the building structural system per the details supplied by the engineer of record. The floor mounting locations for NEMA 1 enclosures are shown below.

Use 1/2-inch (13 mm) Grade 5 (minimum) bolts and hardened washers. Torque bolts to the value specified by the manufacturer of the anchor.

Figure 14: Typical Floor Plan (Bottom View)—Seismic

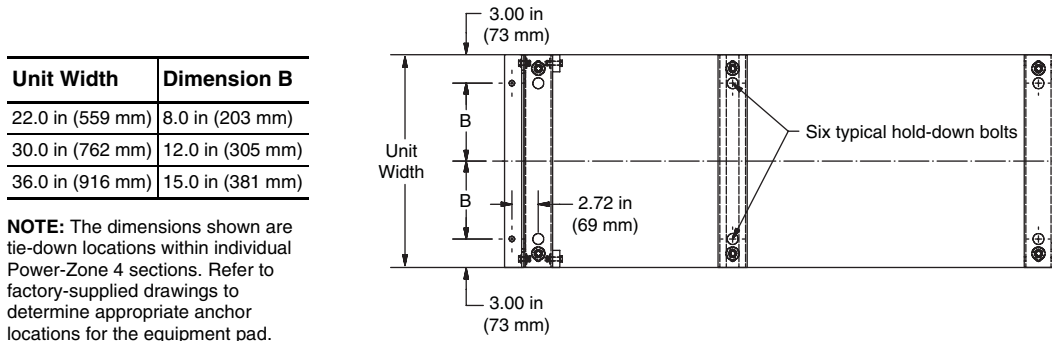
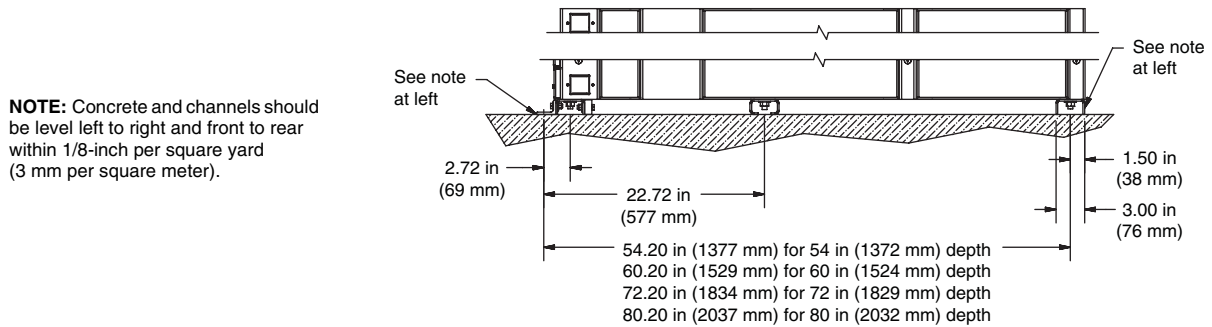


Figure 15: Typical Floor Plan (Side View)—Seismic



Connect the Bus

All connections for the main, neutral, and ground bus between sections are made by means of bolted splice plates (plated).

Prepare the Bus Joints

<h2>CAUTION</h2> <p><b>POOR BUSBAR CONNECTIONS</b></p> <p>Do not use abrasive cleaners on the bus joints. This may cause high resistance connections.</p> <p><b>Failure to follow this instruction can result in equipment damage.</b></p>
--

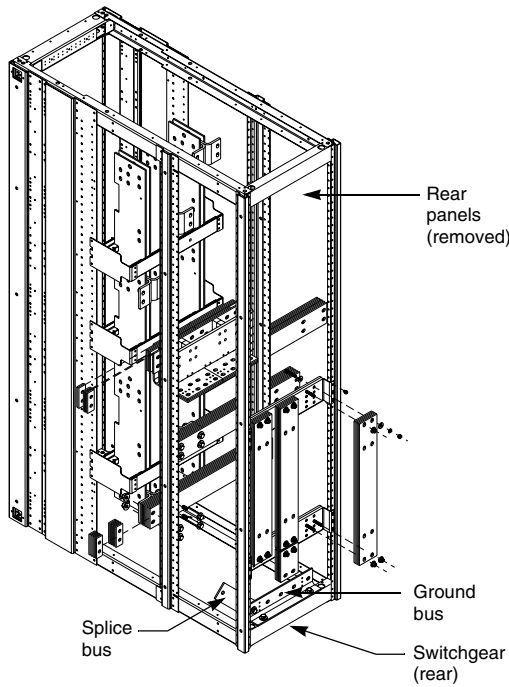
All bus joints are plated to provide a reliable electrical connection.

1. Remove any dirt, grease, and other foreign material from bus joint surfaces before they are joined.
2. Wipe surfaces clean with a lint-free cloth and denatured alcohol.
3. Wipe the joint dry with a clean, lint-free cloth.

<sup>1</sup>Seismic hazard for site specific locations as defined by the current edition of the International Building Code or NFPA 5000 or relevant local building code or consulting engineer of record.

Splice the Ground Bus

**Figure 16: Splicing the Ground Bus**



All bus joints are plated to provide a reliable electrical connection.

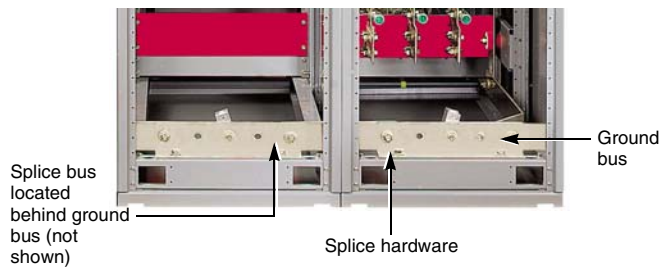
1. Remove any dirt, grease, and other foreign material from bus joint surfaces before they are joined.
2. Wipe surfaces clean with a lint-free cloth and denatured alcohol.
3. Wipe the joint dry with a clean, lint-free cloth.

The ground splice bus (Figure 16) is shipped in an upright position at the bottom rear of the switchgear section. See Figures 16 and 17 for steps 1 through 5.

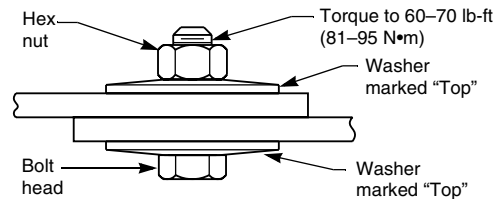
1. Remove the rear panels from the switchgear.
2. Remove the 1/2-13-inch hardware securing the splice bus to the ground bus. Retain this hardware for reuse.
3. Remove the 1/2-13-inch hardware from the other end of the splice bus. Retain this hardware for reuse.
4. Align the splice bus with the adjacent ground bus.
5. Install the 1/2-13-inch hardware retained in steps 2 and 3.
6. Torque all 1/2-13-inch hardware to 60–70 lb-ft (81–95 N•m). See Figure 18.

**NOTE:** The convex side (marked “Top”) of one conical washer should be against the bolt head and the convex side of the second conical washer should be against the hex nut.

**Figure 17: Ground Bus Connected**

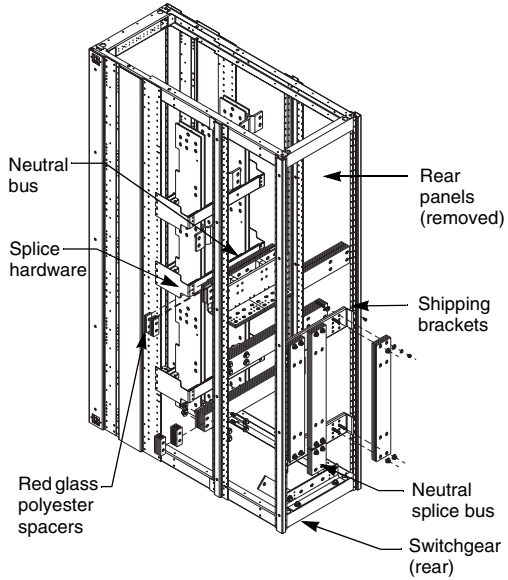


**Figure 18: Installing Conical Washers**



### Splice the Neutral Bus

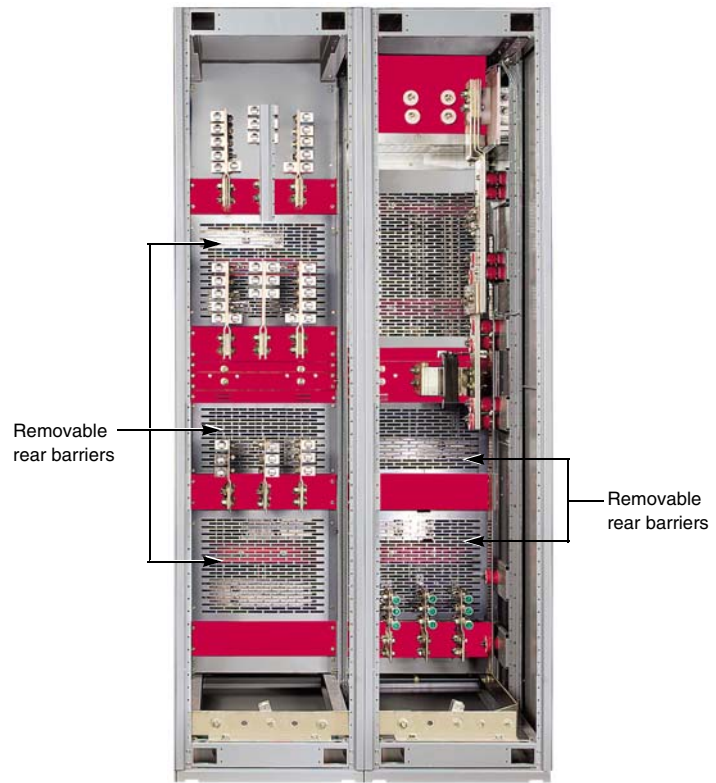
**Figure 19: Splicing the Neutral Bus**



Neutral splice bus (Figure 19) is shipped mounted to brackets at the rear of the switchgear section. See Figure 19 for steps 1 through 5.

1. Remove the two 3/8-16-inch hardware securing the splice bus and discard.
2. Remove the splice bus. Retain for reuse.
3. If rear barriers are provided (Figure 20 on page 22), remove them to gain access to the neutral splice bus area. Retain for reuse.
4. Remove the 1/2-13-inch splice hardware in the sections to be spliced. Retain for reuse.
5. Remove the red glass polyester spacers and discard.

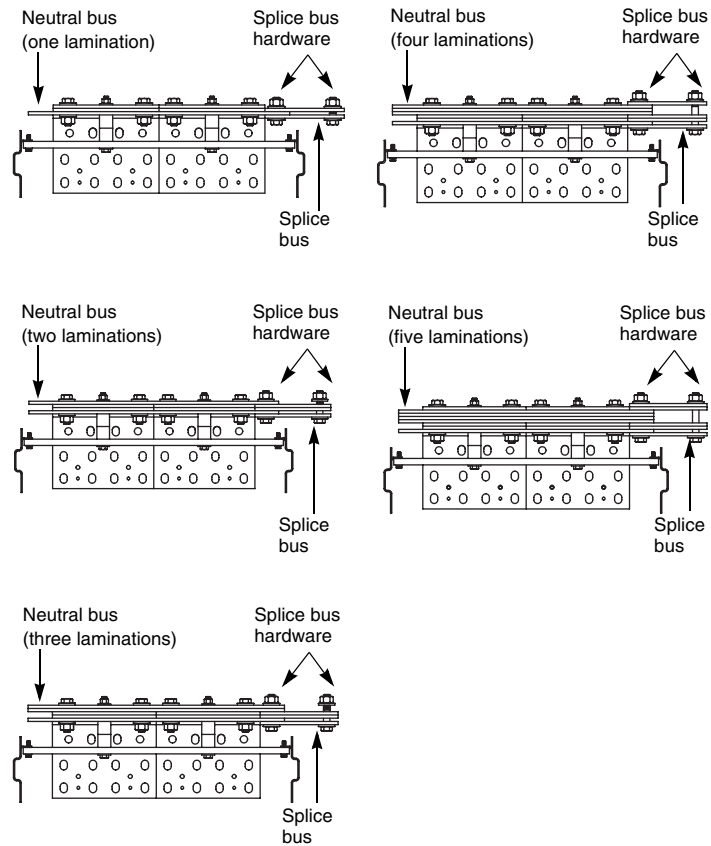
**Figure 20: Removing Rear Barriers (If Provided)**



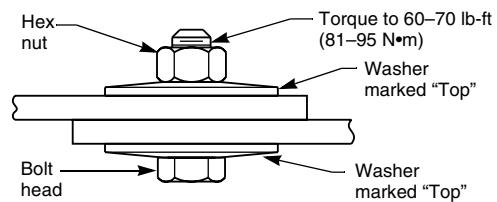
**Bus Compartment (rear view)**

6. Position and install the neutral splice bus (Figure 21). Also see Figure 19 on page 22.
7. Install the 1/2-13-inch splice hardware removed in step 4 on page 22. Note the orientation of the splice hardware in Figure 21.
8. Torque all 1/2-13-inch hardware (Figure 18) to 60–70 lb-ft (81–95 N•m).  
**NOTE:** The convex side (marked “Top”) of one conical washer should be against the bolt head and the convex side of the second conical washer should be against the hex nut.
9. If supplied, install the rear barriers (Figure 20 on page 22) removed in step 3 on page 22.

**Figure 21: Neutral Bus Laminations**

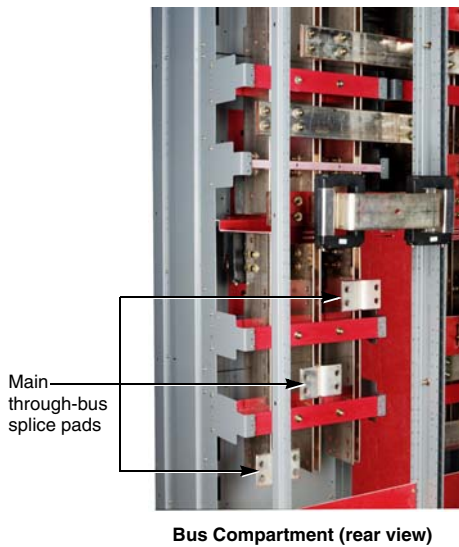


**Figure 22: Installing Conical Washers**



Splice the Main Through-Bus

**Figure 23: Typical Main Through-Bus Splice Pads**



Main through-bus splice bars (Figure 24) are shipped mounted to brackets at the rear of the switchgear section. See Figure 24 for steps 1 through 8.

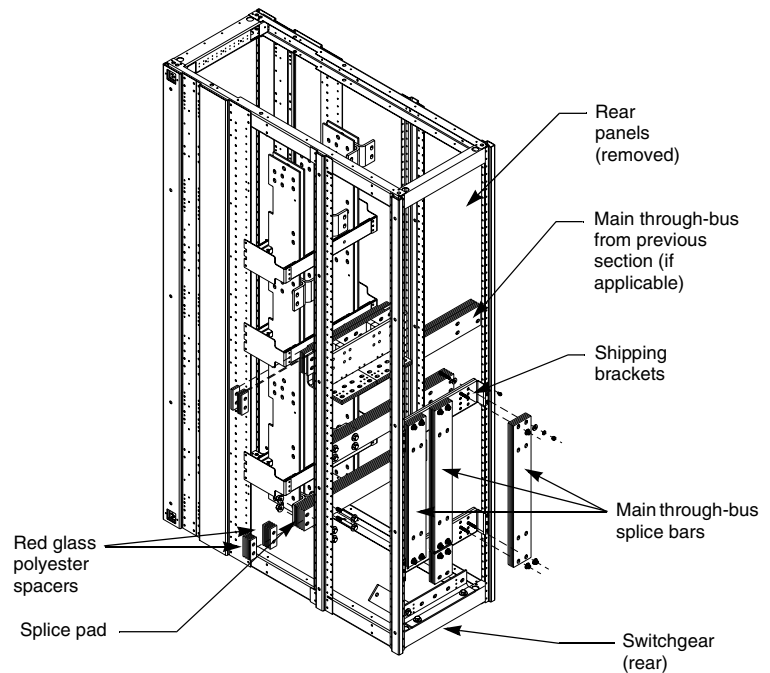
1. Remove the twelve 3/8-16-inch hardware securing the splice bus and discard.
2. Remove the splice bus, keeping each set together as shipped. Retain for reuse.
3. Discard the shipping brackets and bracket mounting hardware.
4. If rear barriers are provided (Figure 20 on page 22), remove them to gain access to the main through-bus splice area. Retain for reuse.
5. If bus boots are installed over the main through-bus splice pads, use a pair of wire cutters to snip off just enough wire ties to gain access to the main through-bus splice pads. Do not completely remove the boots.
6. Remove the 1/2-13-inch hardware supplied with the equipment at the splice pads. Retain for reuse.

**NOTE:** Splice pads may be in the top or bottom half of the switchgear section. Splice pads in the bottom location are shown in Figures 23, 24, and 25 (on page 25).

7. Remove the red glass polyester spacers and discard.
8. Determine individual phase placement by matching the hole pattern and hole spacing in the splice bars with the hole pattern and hole spacing in the splice pads in the sections to be spliced.

See Table 1 on page 25 to determine the number of laminations required per phase.

**Figure 24: Splicing the Main Through-Bus**

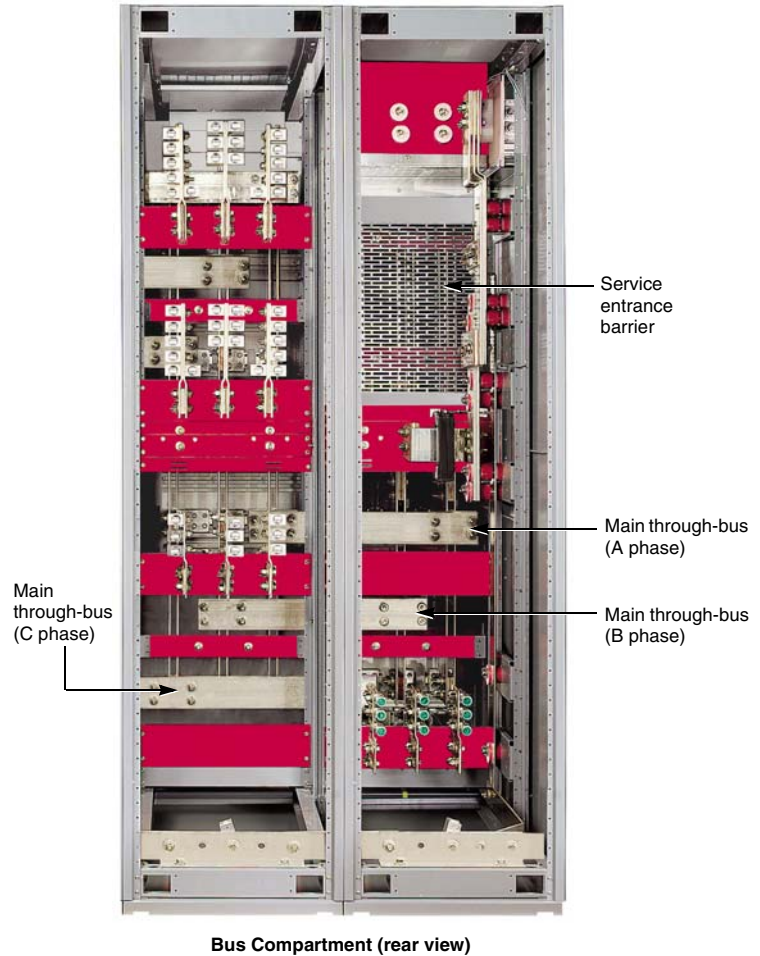


**Table 1: Number of Laminations Required Per Phase**

Main Through-Bus Ampacity	Standard Rating	Optional Rating
<b>Without Insulated Bus Option</b>		
1600 A ≤ 100 kA SCCR	1	2
1600 A > 100 kA SCCR	2	2
2000 A ≤ 100 kA SCCR	1	2
2000 A > 100 kA SCCR	2	2
3200 A (all SCCR)	2	4
4000 A (all SCCR)	3	4
5000 A (all SCCR)	4	5
<b>With Insulated Bus Option</b>		
1600 A ≤ 65 kA SCCR	1	2
1600 A > 65 kA SCCR	2	2
2000 A ≤ 65 kA SCCR	1	2
2000 A > 65 kA SCCR	2	2
3200 A (all SCCR)	2	4
4000 A (all SCCR)	3	4
5000 A (all SCCR)	4	5

**NOTE:** All laminations are 1/4-inch x 4-inch (6 mm x 102 mm) copper bus.

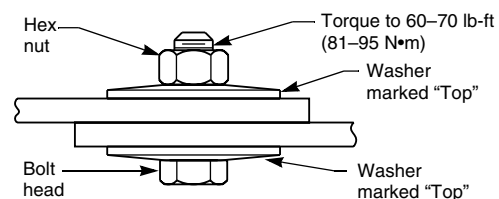
**Figure 25: Typical Main Through-Bus (A, B, and C Phases)**



9. Replace each polyester spacer removed in step 7 on page 24 with a main through-bus splice bar. See Figure 24 on page 24.
10. Install the 1/2-13-inch splice hardware removed in step 6 on page 24. See Figure 24 on page 24.
11. Torque all 1/2-13-inch hardware to 60–70 lb-ft (81–95 N•m). See Figure 18.
 

**NOTE:** The convex side (marked “Top”) of one conical washer should be against the bolt head and the convex side of the second conical washer should be against the hex nut.
12. If supplied, close the bus boots by inserting new wire ties into the attachment holes. Use the wire ties provided (Square D part number 25901-24485).
13. If supplied, install the rear barriers (Figure 20 on page 22), removed in step 4 on page 24.

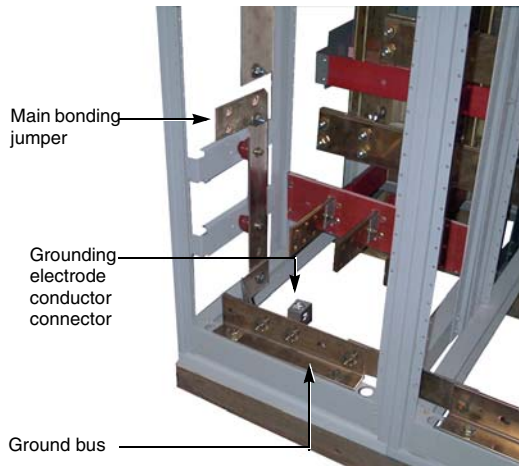
**Figure 26: Installing Conical Washers**



## Grounding and Bonding

Service Equipment (Solidly Grounded Systems)

**Figure 27: Main Bonding Jumper and Grounding Electrode Conductor Connector (Grounded Systems)**



**NOTE:** For purposes of making the determinations below, a system is “grounded” if it is grounded at any point ahead of the switchgear, whether the grounded conductor (neutral) is carried through to the loads, or not.

For *solidly grounded* systems used as either service equipment or as the main switchgear on a separately derived system:

1. Install the grounding electrode conductor from the grounding electrode at the installation site to the grounding electrode conductor connector (ground lug) located on the switchgear ground bus (or on the neutral bus, if so indicated on the equipment drawing) (Figure 27). Select the proper material and size of the grounding electrode conductor to comply with Sections 250.62 and 250.66 of the NEC. Install the grounding electrode conductor as specified in Section 250.64 of the NEC.
2. Install the main bonding jumper between the neutral bus and the ground bus (Figure 27). Refer to Tables 2 and 3 for torque values.

**NOTE:** If the switchgear is fed from multiple sources (for example, double-ended systems), there may be two or more main bonding jumpers to install.

**Table 2: Incoming, Branch, Neutral and Ground Lugs**

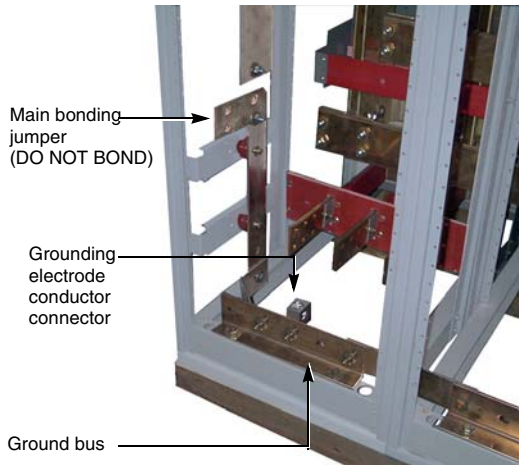
Socket Size Across Flats	Torque Value
1/4 in (6 mm)	180 lb-in (20 N•m)
5/16 in (8 mm)	250 lb-in (28 N•m)
3/8 in (10 mm)	340 lb-in (38 N•m)
1/2 in (13 mm)	450 lb-in (51 N•m)
See exception on next line	
1/2 in (13 mm) 3/0-750 kcmil	620 lb-in (70 N•m)

**Table 3: Multiple Conductor Neutral and/or Ground Bus**

Screw Type	Lug Wire Range	Conductor Size	Torque Value
Slotted head	14–4	14-10 Cu, 12-10 Al	20 lb-in (2 N•m)
		8 Cu-Al	25 lb-in (3 N•m)
		6-4 Cu-Al	35 lb-in (4 N•m)
	14–1/0	14-8 Cu-Al	36 lb-in (4 N•m)
6-1/0 Cu-Al		45 lb-in (5 N•m)	
Socket head	14–1/0	All	100 lb-in (11 N•m)
	6-300 kcmil	All	275 lb-in (31 N•m)

Service Equipment (Ungrounded Systems)

**Figure 28: Main Bonding Jumper and Grounding Electrode Conductor Connector (Ungrounded Systems)**



For *ungrounded* systems used as either service equipment, or as the main switchgear on a separately derived system:

1. Install the grounding electrode conductor from the grounding electrode at the installation site to the grounding electrode conductor connector (ground lug) located on the switchgear ground bus (Figure 28).
2. Select the proper material and size of the grounding electrode conductor to comply with Sections 250.62 and 250.66 of the NEC. Install the grounding electrode conductor as specified in Section 250.64 of the NEC.

Not Service Equipment

To connect the switchgear frame and ground bus to the service ground for *grounded* or *ungrounded* systems, when switchgear is used neither as service equipment, nor as the main switchgear on a separately derived system, use equipment grounding conductors sized according to Section 250.122 of the NEC.

High-Impedance Grounded Neutral Systems

For *high-impedance grounded neutral systems*, ground the system following instructions provided with the system grounding equipment and in compliance with Section 250.36 of the NEC.

Confirm that the switchgear frame and ground bus are bonded in accordance with Section 250.102 of the NEC.

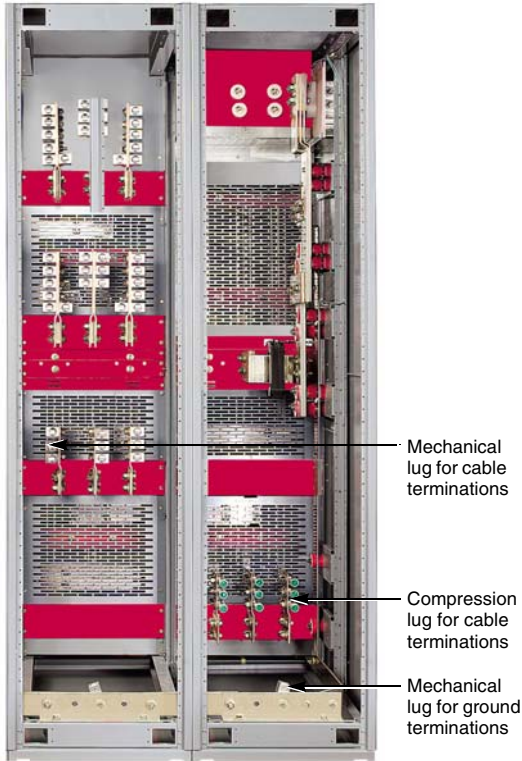
**Connect the Power Cables, Controls, and Wiring**

Connect the Power Cables

<b>CAUTION</b>
<b>LOSS OF EQUIPMENT GROUND-FAULT PROTECTION</b> Do not connect grounding conductors to any load neutral terminal(s). <b>Failure to follow this instruction can result in equipment damage.</b>

**NOTE:** When connecting power cables, use 90 °C insulated conductors based on the ampacity of 75 °C conductors unless otherwise indicated by supplemental instructions.

Figure 29: Connecting the Cables



Cable compartment (rear view)

Power-Zone 4 switchgear is provided with compression or mechanical type lugs (Figure 29) for terminating the main power cables.

1. Determine the phase of each cable before making the connection.

**NOTE:** Viewing the switchgear from the front, the bus sequence is phased A-B-C top-to-bottom, front-to-rear, or left-to-right.

Non-standard arrangements may be necessary to meet specific requirements. If so, the bus is marked A, B, and C in the order specified by the customer.

If an optional neutral is provided, all the connections for the neutral are labeled.

2. Avoid sharp turns, corners, and edges when forming cables for termination within the switchgear. This reduces the risk of damage to equipment or weakening of the cable insulation. The cable manufacturer's instructions should be followed in determining the minimum bending radii of the cables. This will vary with the type and size of cable involved. Refer to the NEC requirements for more information regarding minimum bending radii of cables.
3. Securely lace and support the line and load cables as directed in "Conductor Restraint for Short-Circuit Current Rating (SCCR)" on page 29.

**NOTE:** This helps avoid strain or load on the terminals.

4. Once all appropriate cables are connected, reinstall the rear panels removed in step 1 under "Splice the Ground Bus" on page 21.

Conductor Restraint for Short-Circuit Current Rating (SCCR)

## CAUTION

**HAZARD OF CONDUCTOR MOVEMENT UNDER SHORT-CIRCUIT CONDITIONS**

Restrain conductors in switchgear installation based on Table 4.

**Failure to follow this instruction can result in equipment damage.**

**Table 4: Conductor Restraint Requirements**

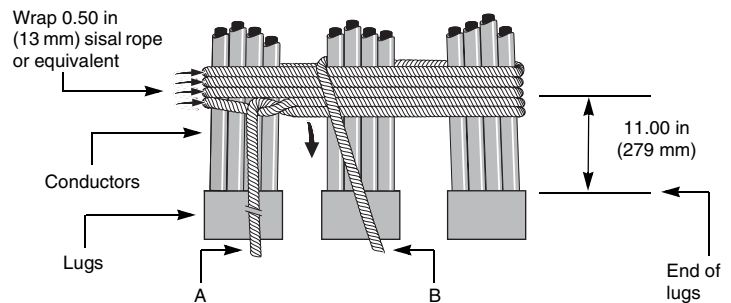
Supply Cables	85 kA	100 kA	130 kA	200 kA
2000 A	No	No	Yes	Yes
3200 A	No	No	Yes	Yes
4000 A	No	No	No	No
5000 A	No	No <td No	No	
Masterpact NT Circuit Breaker Load Cables	85 kA	100 kA	130 kA	200 kA
800 A	No	Yes	Yes	Yes
Masterpact NW Circuit Breaker Load Cables	85 kA	100 kA	130 kA	200 kA
800 A	Yes	Yes	Yes	Yes
1600 A	Yes	Yes	Yes	Yes
2000 A	Yes	Yes	Yes	Yes
3200 A	No	No	Yes	Yes
4000 A	No	No	No	No

Refer to Table 4 to determine if cable restraints are required. If restraints are required, perform the following steps.

**NOTE:** Wrap conductors using 1/2-inch (13 mm) diameter sisal rope or equivalent.

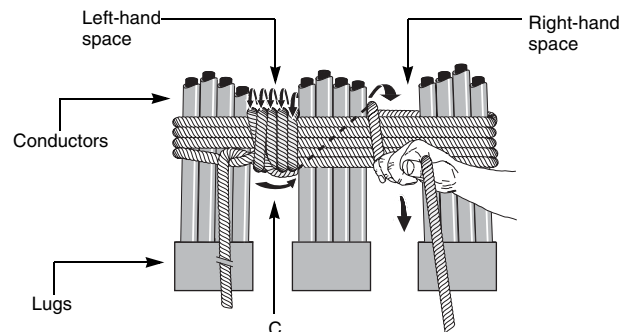
1. Begin wrapping the conductors (Figure 30) a maximum distance of 11 in. (279 mm) from the end of the lugs. Continue to wrap the conductors on 11-in. (279 mm) center(s) up to the point where the conductors leave the enclosure.
  - a. Wrap the conductors four (4) times as shown, leaving 3 ft. (1 m) of excess rope at the first end (A).
  - b. Pull the rope (B) taut.

**Figure 30: Wrapping Conductors**



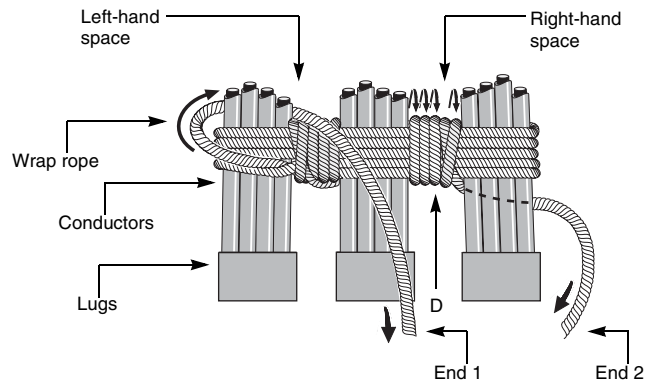
2. Wrap the rope several times (Figure 31) until the space between the conductors is completely filled.
  - a. Weave the final rope loop underneath the previous loop (C).
  - b. Bring the rope through the right-hand space.
  - c. Pull the rope taut.

**Figure 31: Wrapping the Space Between Conductors**



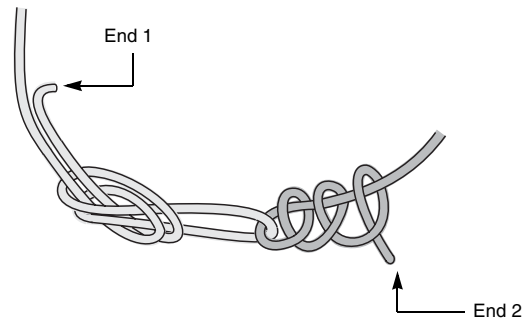
3. Wrap the rope several times until the space between the conductors (Figure 32) is completely filled.
  - a. Weave the final rope loop underneath the previous rope loop (D).
  - b. Pull the rope taut.

**Figure 32: Finish Wrapping the Space Between Conductors**



4. Tie the rope ends (1) and (2) together (Figure 33) until they are taut. Cut off excess rope, and tape ends to prevent fraying.

**Figure 33: Tying Rope Ends Together**



5. Recheck torques of wire binding screws after securing the conductors.
 

**NOTE:** Refer to the torque label supplied with the switchgear for torque values.

Connect the Controls and Wiring

1. Locate and remove the wiring compartment covers (Figure 34) at the split from the front of the switchgear.

**Figure 34: Removing the Wiring Compartment Covers**



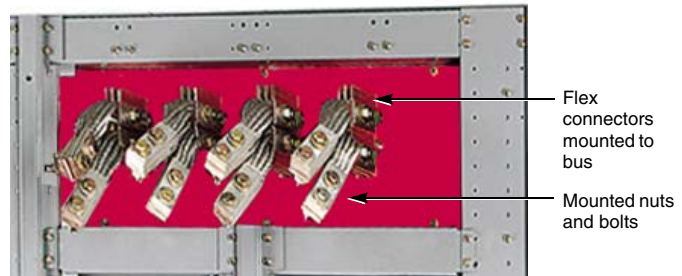
2. Reconnect all pull-apart terminal blocks that cross a shipping split to their correct plugs provided for this purpose.  
**NOTE:** The terminal blocks have been tagged at the factory and are shown on the connection diagrams for the installation.
3. Connect any controls for remote mounted relays, control switches, and instruments to a set of terminal blocks located on either the rear frame of the vertical section or in the instrument compartment. Refer to the customer “connection diagram” drawings.
4. Check control wiring with the connection diagram to confirm all connections have been made properly, current transformer circuits completed, and loose connections tightened properly.

**NOTE:** If the control power source is other than an internal control power transformer, the wires from the source to the switchgear must be of adequate size to avoid excessive voltage drop during operation.

### Mount the Flex Connectors

This section contains instructions on how to mount flex connections on Power-Zone 4 switchgear transformer stabs or adapter bus.

**Figure 35: Typical Flex Connections**



Switchgear (side)

## ⚠ DANGER

### HAZARD OF ELECTRIC SHOCK, EXPLOSION, OR ARC FLASH

- Turn off all power supplying the transformer before installing the transformer flex connectors.
- Always use a properly rated voltage sensing device to confirm power is off.

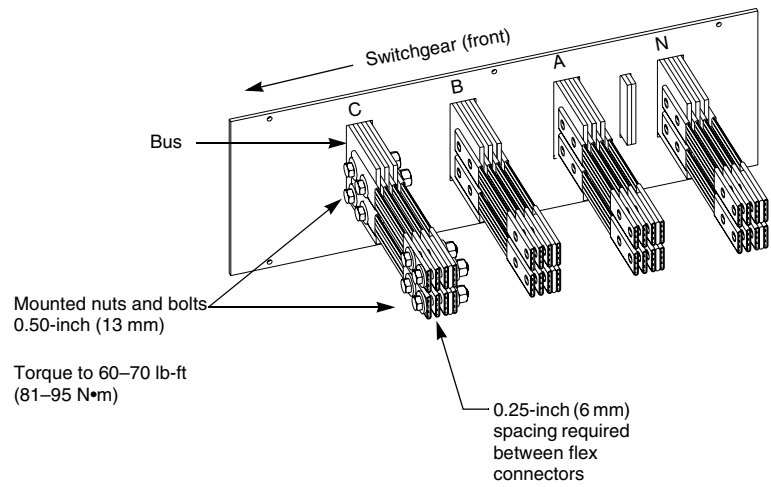
**Failure to follow these instructions will result in death or serious injury.**

**NOTE:** Mount flex connectors in the top holes of the transformer bus on half neutral bus ratings.

1. Turn off all power supplying the transformer before installing the transformer flex connectors. Use a properly rated voltage sensing device to confirm all power is off.
2. Attach the appropriate flex connector (Figure 36 on page 32) to the transformer stabs or adapter bus.
3. Attach the accompanying 1/2-inch (13 mm) bolts and nuts to each flex connector, and torque to 60–70 lb-ft (81–95 N•m).

Figure 36 on page 32 shows a typical transformer connection situated on the right side of the Power-Zone 4 switchgear.

**Figure 36: Typical Transformer Connection on Right Side of Switchgear**



The quantity and size of the transformer stabs will vary according to the rating of the transformer.

**Table 5: Transformer Flex Connections**

Rating	Bus Type	Quantity (Phase or Neutral)
1600 A	Phase Bus	5
	Full Neutral Bus	5
	Half Neutral Bus	3
2000 A	Phase Bus	6
	Full Neutral Bus	6
	Half Neutral Bus	3
3200 A	Phase Bus	8
	Full Neutral Bus	8
	Half Neutral Bus	4
4000 A	Phase Bus	10
	Full Neutral Bus	10
	Half Neutral Bus	5
5000 A	Phase Bus	13
	Full Neutral Bus	13
	Half Neutral Bus	7

### Install the Traveling Lifter

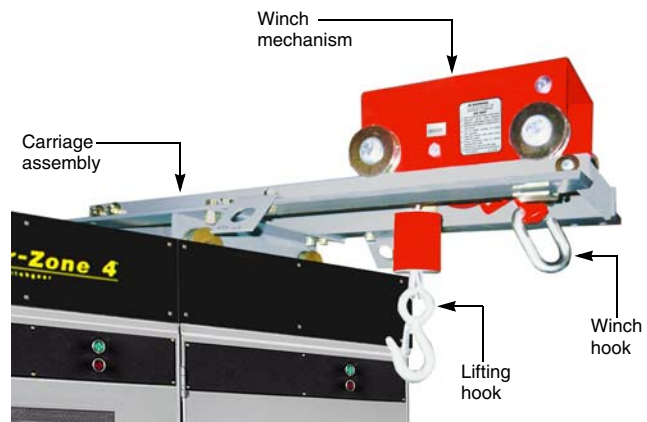
**⚠ DANGER**

**HAZARD OF FALLING OBJECTS OR EQUIPMENT**

- Do not install or operate the traveling lifter assembly unless two or more qualified personnel are present.
- Do not change the mechanics or design of the traveling lifter.
- Always keep the gears on the traveling lifter well lubricated. Never allow the gears to run dry.
- Never operate the traveling lifter with broken or distorted teeth, a bent handle, cable deterioration, or other obvious distortions.
- Do not overload, snarl, kink, or knot the cable.
- Never let the traveling lifter drum unwrap completely so the load is supported completely and only by the anchor.
- Do not load the traveling lifter beyond its rated load capacity of 300 lb (135 kg).
- Do not move the traveling lifter by pulling on a suspended circuit breaker.
- Do not walk or stand under suspended loads or the traveling lifter assembly.

**Failure to follow these instructions will result in death or serious injury.**

Figure 37: Typical Traveling Lifter Assembly



Align the Sections and Rails

## CAUTION

### HAZARD OF ROOF DEFLECTION

Do not climb on the roof of the switchgear sections. The switchgear is not designed to support additional weight.

**Failure to follow this instruction can result in equipment damage.**

After the switchgear has been moved to its final location, check for proper rail alignment before installing the traveling lifter assembly.

Both front and rear rails must be aligned to provide proper operation of the traveling lifter assembly. Alignment is particularly critical between vertical sections that are split for shipping purposes.

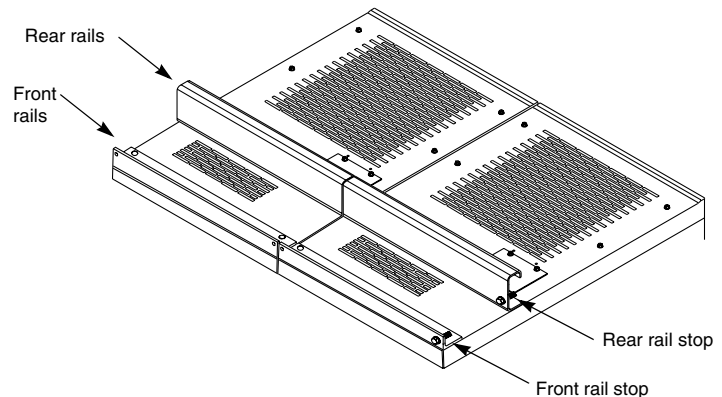
If the vertical sections were assembled at the factory, the rails and section(s) should already be aligned. However, this procedure is important to confirm alignment of the vertical sections and rails.

**NOTE:** A minimum of 16 inches (406 mm) of unrestricted workspace is required from one side of the switchgear lineup in order to install the carriage assembly. If this is NOT possible after final placement of the switchgear, install the traveling lifter assembly before moving the switchgear to its final location. Do not move the carriage assembly when placing the switchgear.

1. After the switchgear is placed in its final location, align the sections (Figure 38) so that the front and rear rails line up in all directions.

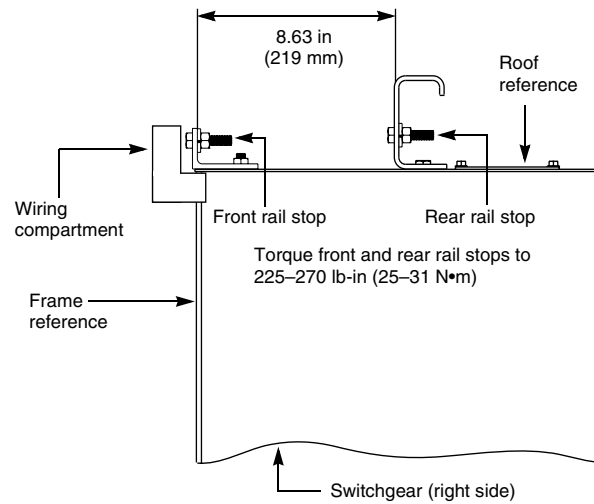
**NOTE:** In Figure 38, the wiring compartment is removed from the front of the switchgear for clarity.

**Figure 38: Aligning the Vertical Sections**



2. Align the front and rear rails (Figure 39 on page 35) to within 1/16-inch (2 mm) for proper operation of the traveling lifter. This is critical for ease of movement transversely along the width of the switchgear.

Figure 39: Aligning the Front and Rear Rails



Rail Alignment Troubleshooting Steps

- Place shims under the equipment sections to achieve proper vertical alignment.
- Loosen the rail bolts to realign the front and rear rails; then tighten bolts, and torque to 225–270 lb-in (25–31 N•m).

Install the Carriage Assembly

**⚠ DANGER**

**HAZARD OF FALLING EQUIPMENT OR LOAD**

- Do not remove the front rail stops after the carriage assembly is installed.
- The front rail stops (bolts) must be assembled on the front rails to prevent the lifter from rolling off the end of the switchgear lineup.

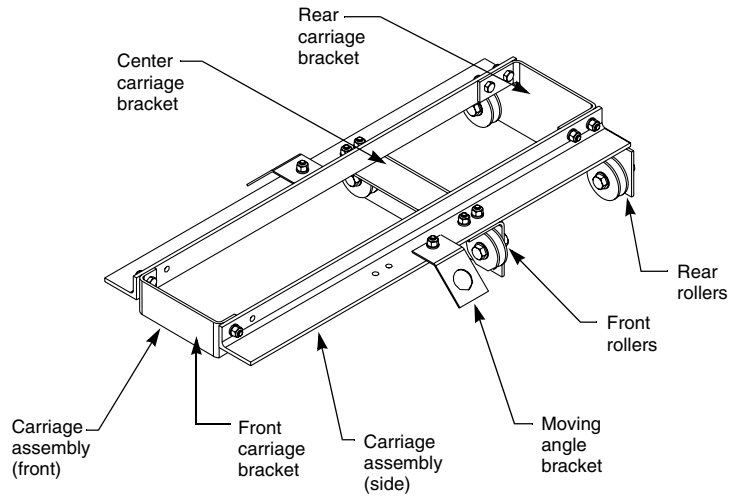
**Failure to follow these instructions will result in death or serious injury.**

**NOTE:** The carriage assembly is packed separately from the switchgear.

- Remove the front and rear rail stops (Figure 39) from the end section of the switchgear on which the carriage assembly will be installed. Retain the front and rear rail stops and hardware.
- Remove the shipping banding securing the carriage assembly to the pallet.
- Position the lifting equipment under or around the carriage assembly.
- Confirm that support is adequate and that the carriage assembly is held securely.

- Before raising the carriage assembly (Figure 40), orient it so that the front of the carriage assembly lines up with the front of the switchgear.

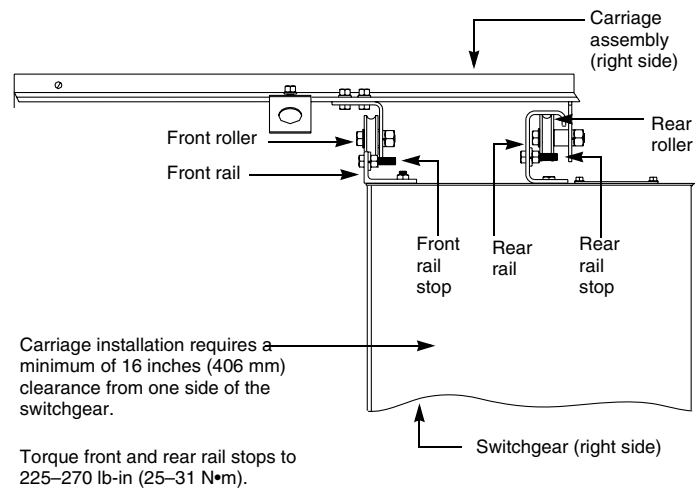
**Figure 40: Carriage Assembly (Front and Side View)**



- Carefully raise the carriage assembly (this requires two qualified personnel), and move it into place on the front and rear traveling lifter rails as shown in Figure 41.

**NOTE:** In Figure 41, the wiring compartment is removed from the front of the switchgear for clarity.

**Figure 41: Installing the Carriage Assembly**



- Position the front rollers on top of the front rails and the rear rollers underneath the rear rails.
- Slide the carriage along rails until it clears the front lifter stop position.
- After the carriage assembly is in place, reinstall the front and rear rail stops (Figure 41) removed in step 1, and torque to 225–270 lb-in (25–31 N•m).

Install the Winch Mechanism

## ⚠ WARNING

### HAZARD OF FALLING EQUIPMENT OR LOAD

- Always keep 4 to 5 wraps of cable on the winch mechanism drum.
- Never let the drum unwrap completely, so that the load is supported only by the anchor.

**Failure to follow these instructions can result in serious injury or equipment damage.**

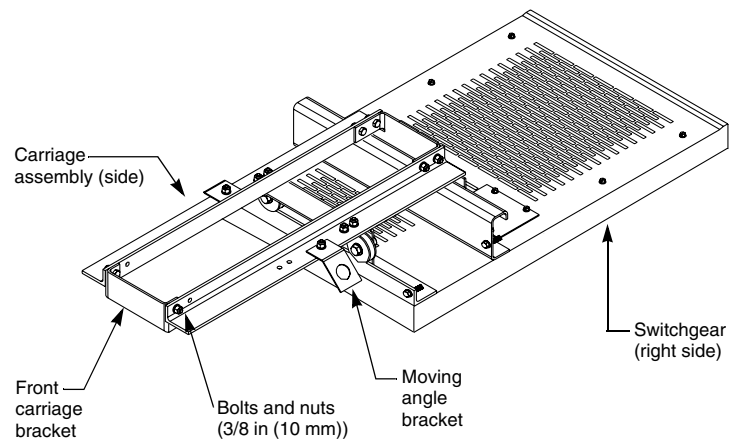
Perform the following steps to install the winch mechanism on top of the carriage assembly.

**NOTE:** The winch mechanism is packed separately from the switchgear.

1. Remove the front carriage bracket (Figure 42) from the carriage assembly. Retain the bracket and hardware.

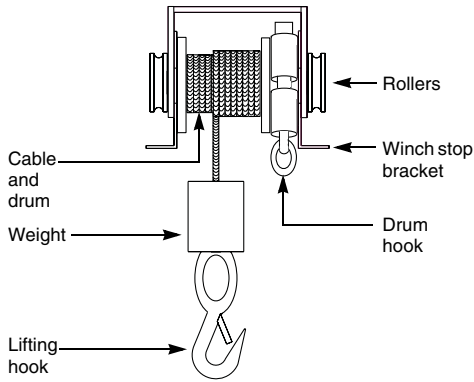
**NOTE:** In Figure 42, the wiring compartment is removed from the front of the switchgear for clarity.

**Figure 42: Removing the Front Carriage Bracket**



2. Unpack the winch mechanism shipping carton contents near the switchgear.
3. If needed, lubricate the winch gears with heavy gear lubricant.  
**NOTE:** For best results, keep the gears lubricated. In normal operating conditions, use a heavy gear lubricant. In dirty or gritty conditions, use a dry lubricant, such as dry graphite.
4. Confirm that the cable is wrapped firmly around the drum. Never allow fewer than 4 to 5 cable wraps around the drum.

**Figure 43: Winch Mechanism (Front View)**

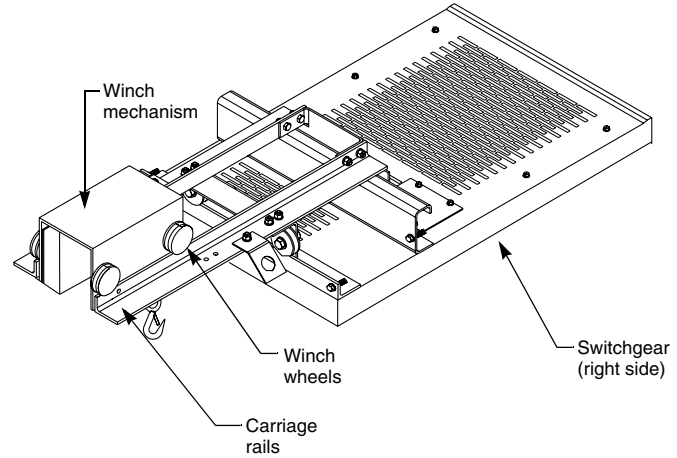


5. Before raising the winch mechanism, orient it (Figure 43) so that the front of the winch mechanism lines up with the front of the switchgear.
6. Install the winch mechanism (Figure 44) to the carriage assembly by rolling the winch wheels onto the carriage rails.

**NOTE:** Confirm that the winch stop brackets are under the carriage rails.

In Figure 44, the wiring compartment is removed from the front of the switchgear for clarity.

**Figure 44: Installing the Winch Mechanism**

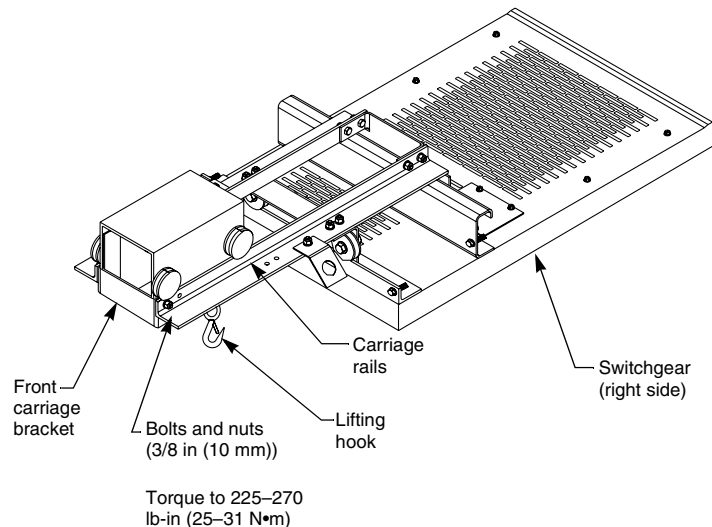


7. After the winch mechanism is in place, reinstall the front carriage bracket (Figure 45) removed in step 1 on page 37, and torque to 225–270 lb-in (25–31 N•m).

**NOTE:** Confirm that the winch stop brackets are behind the front carriage bracket and under the carriage rails before tightening the carriage bracket and hardware.

In Figure 45, the wiring compartment is removed from the front of the switchgear for clarity.

**Figure 45: Installing the Front Carriage Bracket**



Inspect and Test Before Operation

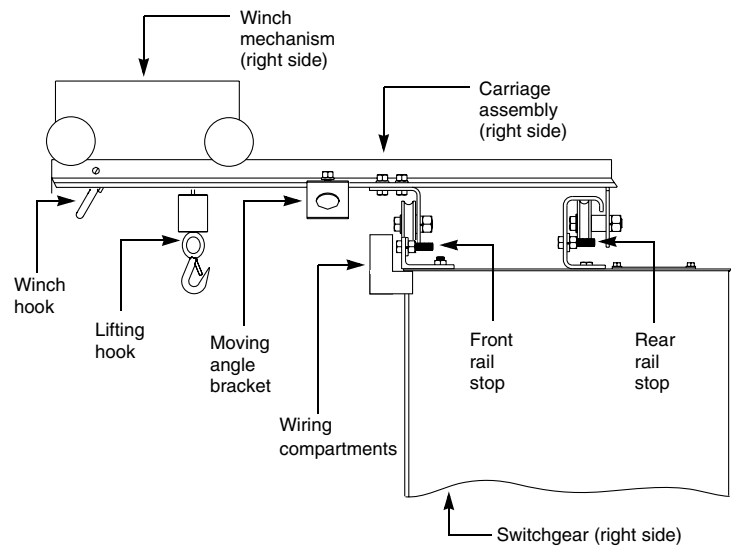
Once the traveling lifter is installed completely, visually inspect it (Figure 46) for any distortion.

- ❑ Confirm that the rails and sections are aligned.
- ❑ Confirm that the front and rear rails stops have been installed correctly.
- ❑ Confirm that the carriage and winch mechanism have been installed correctly.
- ❑ Confirm that the cable has been fastened securely around the winch drum.
- ❑ Confirm that the winch gears are well lubricated.

**NOTE:** For normal operation, use a heavy gear lubricant. In very dirty or gritty conditions, use a dry lubricant, such as dry graphite, to lubricate the gears. Never allow the gears to run dry.

- ❑ If applicable, remove handling means and any obstructions on top of the unit that could inhibit operation of the traveling lifter.

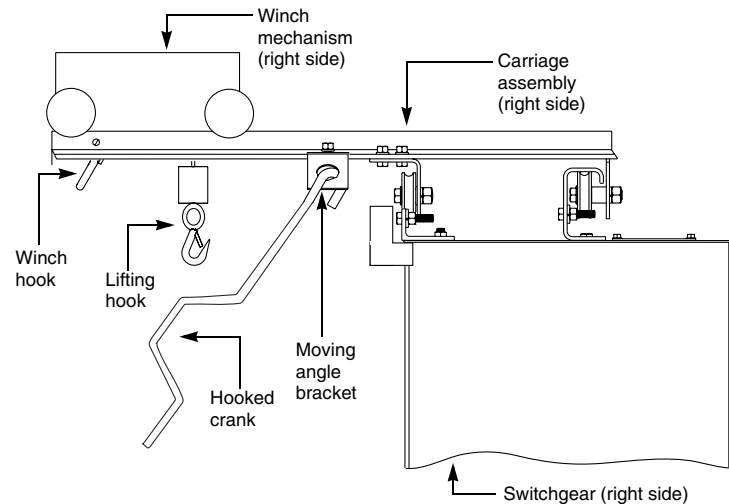
**Figure 46: Visually Inspecting the Traveling Lifter**



Use the traveling lifter hooked crank to move the carriage assembly from side-to-side along the top of the vertical sections to confirm that the traveling lifter operates properly.

1. Locate the hooked crank, and insert the hooked end through the moving angle bracket as shown in Figure 47.

**Figure 47: Testing the Carriage Assembly**

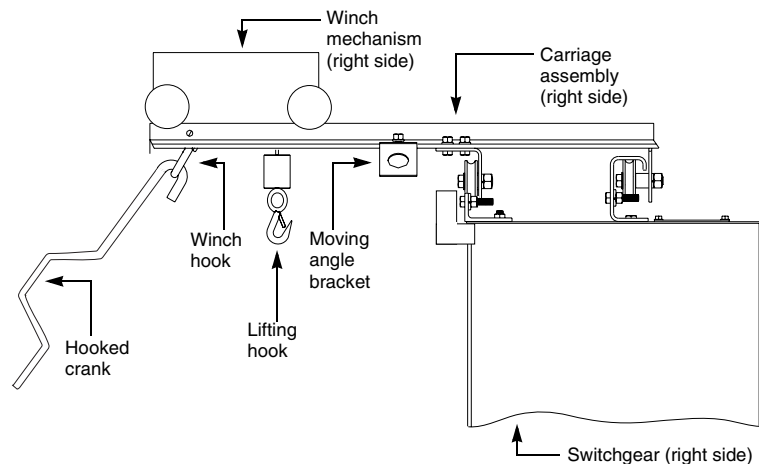


2. Pull the hooked crank so that the carriage assembly rolls smoothly along the rails.

**NOTE:** If the carriage assembly does not roll smoothly, reinspect the top of the unit for obstructions or for front and rear rail misalignment.

3. Insert the hooked end of the traveling lifter hooked crank through the winch hook as shown in Figure 48.

**Figure 48: Testing the Winch Mechanism**



4. To operate the traveling lifter:
  - a. Turn the crank counterclockwise to lower the lifting hook.
  - b. Turn the crank clockwise to raise the lifting hook just below the winch hook.

**NOTE:** If the winch mechanism does not raise or lower the lifting hook, reinspect the unit for obstructions or adequate gear lubrication.

### Assemble the Circuit Breaker Lifter Bars

**Table 6: Circuit Breaker Lifter Bar Assembly**

Circuit Breaker Type	Amperes	Circuit Breaker Frame Width
NT08 (N1, H1, L1F)	800 A	T-frame 9.50 in (241 mm)
NW08, NW16, NW20, NW32 (N1, H1, H2)	800–3200 A	W-frame 15.75 in (400 mm)
NW08, NW16 (L1, L1F)	800–1600 A	W-frame 15.75 in (400 mm)
NW20 (L1–Feeder, L1F–Feeder)	2000 A	W-frame 15.75 in (400 mm)
NW40, NW50 (H2, L1)	4000–5000 A	Y-frame 31.00 in (787 mm)
NW20, NW32 (L1)	2000–3200 A	Y-frame 31.00 in (787 mm)

## ⚠ DANGER

**HAZARD OF FALLING EQUIPMENT OR LOAD**

- Do not change the mechanics or design of the circuit breaker lifter bar.
- Use the circuit breaker lifter bar (furnished with each switchgear order) in conjunction with the traveling lifter assembly or floor crane to lift the circuit breaker.

**Failure to follow these instructions will result in death or serious injury.**

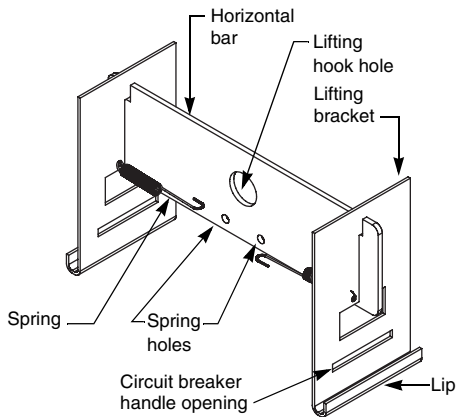
The T-frame circuit breaker lifter bar is used to lift and lower Masterpact NT circuit breakers. The W-frame and Y-frame circuit breaker lifter bars are used to lift and lower Masterpact NW circuit breakers. The size of the circuit breaker determines if the W-frame (standard width) or Y-frame (double width) circuit breaker lifter bar will be used.

Refer to Table 6 to determine which circuit breaker lifter bar to use for assembly.

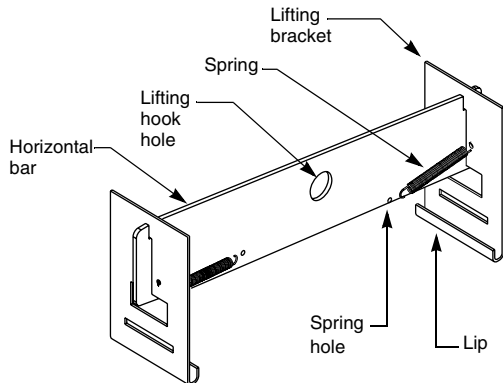
Perform these steps to assemble the T-frame, W-frame, and Y-frame circuit breaker lifter bars (Figures 49, 50, and 51).

- Position the horizontal bar with the lifting hook hole right-side up.
- Note the direction of the lip. Slide the lifting brackets into the grooves on the horizontal bar.
- Attach the springs from the lifting bracket to the spring holes as shown in Figures 49, 50, and 51.

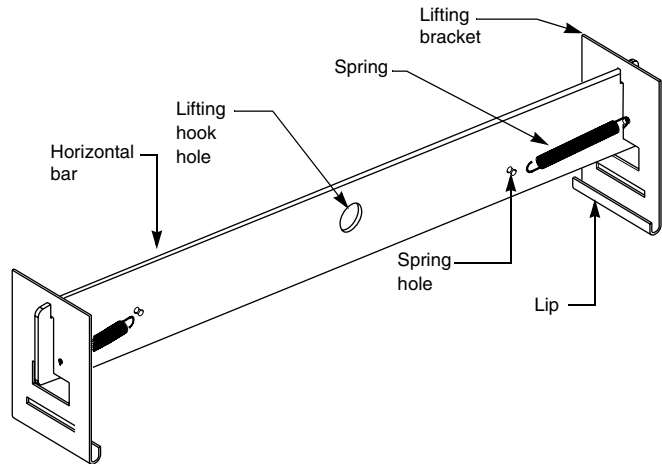
**Figure 49: T-Frame Circuit Breaker Lifter Bar**



**Figure 50: W-Frame Circuit Breaker Lifter Bar**



**Figure 51: Y-Frame Circuit Breaker Lifter Bar**



## Prepare and Install the Circuit Breakers

### **⚠ DANGER**

#### **HAZARD OF FALLING EQUIPMENT OR TIPPING LOAD**

- Never stand under a suspended circuit breaker.
- Use the traveling lifting hook (or other suitable lifting hook) in combination with the circuit breaker lifter bar (supplied with the switchgear) to move the circuit breaker.
- Confirm that the safety catch is properly closed on the lifting hook.

**Failure to follow these instructions will result in death or serious injury.**

Before proceeding further, refer to the job drawings and Masterpact circuit breaker manual. Follow all of the safety precaution instructions detailed in the circuit breaker manual.

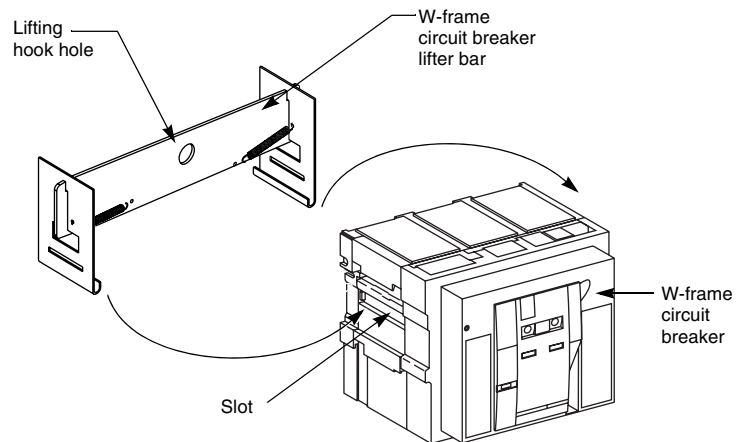
**NOTE:** The circuit breakers may be packed separately from Power-Zone 4 switchgear.

### Lift and Move the Circuit Breakers

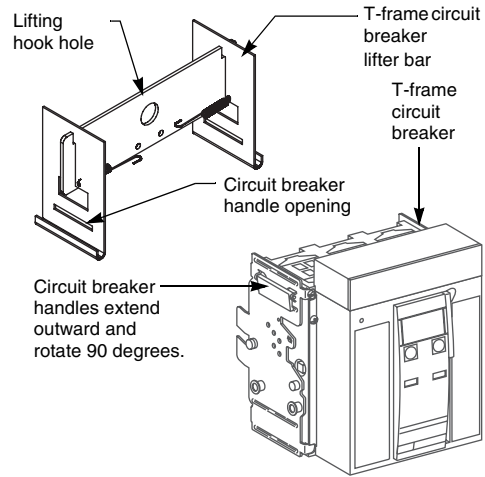
Follow these instructions to move the circuit breaker to the installation site.

1. Unpack the circuit breakers, if necessary, according to the Masterpact circuit breaker manual.
2. Firmly attach the circuit breaker lifter bar into the slots on both sides of the circuit breaker (Figure 52). For a T-frame circuit breaker, extend the circuit breaker handles and place them through the handle slots of the circuit breaker lifter bar (Figure 49 on page 41 and Figure 53 on page 43).

**Figure 52: Attaching the Lifter Bar to the Circuit Breaker**

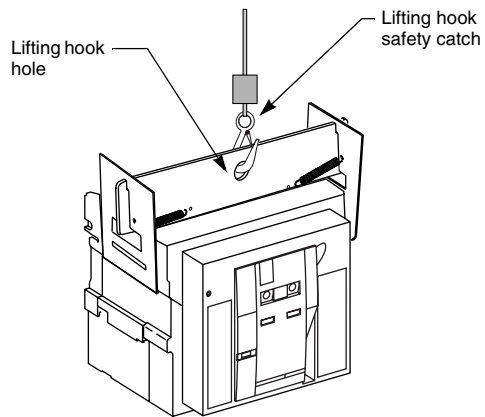


**Figure 53: Attaching the T-Frame Lifter Bar to the Circuit Breaker**



3. Attach the traveling lifter or floor crane lifting hook in the lifting hook hole (Figure 54). Make certain the safety catch is closed on the lifting hook before raising or lowering the circuit breaker.

**Figure 54: Lifting and Moving the Circuit Breaker**



4. Use the traveling lifter or floor crane to lift and move the circuit breaker.
5. Install the circuit breaker per the circuit breaker manual.

## Switchgear Inspection and Testing Before Operation

After Power-Zone 4 switchgear and components have been installed, and all control and primary connections made, perform a final inspection and test before placing the switchgear into service.

When installed correctly, the indoor switchgear conforms to the following requirements:

- ❑ Front panels form a straight, true line; and when transformers and/or other gear are included, the front panels line up or form parallel lines.
- ❑ Units are spaced correctly from center-to-center and perpendicular to the mounting surface.
- ❑ The switchgear is fastened securely to the floor channels or base pad.
- ❑ The shipping sections are bolted together securely.
- ❑ Bus and control wiring connections are connected properly.

Directions for testing relays, instruments, meters, circuit breakers, and other electronic devices that are included in the assembly are given in the manual for each individual device.

Settings for protective devices are determined from a coordination study performed by the purchaser, consultant, or the Schneider Electric coordination group. Factory settings are used for production testing and may not reflect specific site requirements.

Selection of test equipment depends on the rating and type of installation. A multimeter is necessary to check the continuity of control circuits. A megohmmeter is also needed for testing.

### Check the Power Circuit Connections

Perform the following steps to check power circuits.

1. Check wire connections and bolted bus connections to confirm that no loosening or damage occurred during shipment or installation. Immediately replace any covers or barriers that were removed to check connections.  
**NOTE:** Correct torque values are listed on labels located in the cable compartment.
2. If the bus is equipped with insulation:
  - a. Partially remove the insulating bus boots to check bolted bus connections by snipping just enough wire ties to gain access to the connection hardware.
  - b. Reinstall the insulated bus boots immediately after inspection by inserting new wire ties into the attachment holes. Use the wire ties provided (Square D part number 25901-24485).

### Check the External Equipment

Perform continuity checks for the connections to external equipment, such as remote controls, interlock circuits, and auxiliary switches. Refer to the appropriate procedures in the manual for each individual device being tested.

### Check the Auxiliary Equipment

Relays included on or in the instrument panels are set for manufacturing testing levels when shipped.

1. Determine the final relay settings from a coordination study performed by the purchaser, consultant, or Schneider Electric coordination group.
2. Make necessary modifications to the relay settings according to the manual for that particular relay.

Circuit monitors and power meters included on the front of the switchgear may or may not be properly configured. The final configuration of these devices must be set by the purchaser or consultant. Refer to the circuit monitor and power meter manuals when setting these devices.

Check the Equipment Ground-Fault Systems

Paragraph 230-95(c) of the National Electrical Code requires that all equipment ground-fault protection systems be tested when first installed. If the circuit breaker has integral equipment ground-fault protection installed, test it at this time.

Make sure trip unit is powered. The trip unit is powered if:

- The circuit breaker is closed or bottom-fed and has more than 100 V of load voltage on two phases (P or H trip unit only).
- The full-function or hand-held test kit is connected and on.
- The 24 Vdc external power supply is connected.
- An external voltage tap is installed and voltage of more than 100 V is present on two phases (P or H trip unit only).

If this is a radial (single-ended) system, press the ground-fault Push-to-Test button. The circuit breaker will trip, and the trip unit ground-fault indicator light will come on.

Ground-fault protection also may be provided by a means not integral to the circuit breaker, such as an external relay. Follow the manufacturer's instructions for this system, and test it at this time.

Record results on the ground fault system test log.

**NOTE:** If a complete check of the ground-fault system is necessary, use primary injection testing. If the system is multiple source and/or requires field connections at the job site, use primary injection testing.

**NOTE:** Some ground fault systems require field connections at the job site. Consult the switchgear interconnection wiring drawing for details.

Conduct the Electrical Insulation Resistance Test

Power-Zone 4 switchgear and Masterpact circuit breakers are factory-tested for dielectric insulation strength.

Conduct dielectric testing once the switchgear is installed. This testing will help identify short-circuits and undesirable grounds in the switchgear and help identify any potential damage to the insulation during transport and installation.

1. Refer to ANSI/IEEE C37.20.1 for information regarding field dielectric testing.
2. Open all control power and metering disconnects, or remove the fuses from the control circuits. Disconnect the neutral connection at any transient voltage surge suppressor (TVSS) or other electronic device prior to performing the electrical insulation resistance test, then reconnect after the test.
3. With the neutral isolated from the ground and the power switches and circuit breakers open, conduct electrical insulation tests from phase-to-phase, phase-to-ground, phase-to-neutral, and neutral-to-ground.

**NOTE:** If the resistance reads less than one megohm while testing with the branch circuit devices in the Open position, the system may be unsafe and should be investigated. Consult Square D Services at 1-888-Square D (1-888-778-2733) to help you correct any problems.

4. After completing the electrical insulation test, replace all control power fuses that may have been removed and close power disconnects that have been opened. Energize supplies as desired.

<b>⚠ CAUTION</b>
<b>TEST VOLTAGE HAZARD</b>
<ul style="list-style-type: none"> <li>• Remove the long-time rating plug before electrical insulation testing a circuit breaker that has a label stating "Warning: Disconnect Plug Before Dielectric Test".</li> <li>• Some Micrologic® trip units are not rated for voltages that would occur during electrical resistance insulation testing.</li> <li>• Open all control and metering disconnects from the control circuits.</li> </ul>
<b>Failure to follow these instructions can result in personal injury or equipment damage.</b>

## Section 5—Pre-Energizing Checkout Procedure

### CAUTION

#### LOOSE FUSE CLIPS

Do not pry open or spread the fuse mounting clips. This can cause a loose connection, resulting in overheating.

**Failure to follow this instruction can result in equipment damage.**

Conduct a complete inspection **before** the switchgear is energized to ensure that all components function and operate properly. **Complete every step of the checkout procedure listed before energizing the switchgear.**

1. Check all field-installed bus bar connections.
2. Check all accessible connections for tightness.
3. Check all factory and field-installed lug terminations for tightness.
4. Check the rigidity of all bus bar supports.
5. Check the switchgear enclosure for dents or other damage that reduces electrical clearances inside the switchgear.
6. Remove all foam blocks, or other temporary cushioning or retaining material, from the electrical devices.
7. Open and close all circuit breakers and other operating mechanisms, checking for correct alignment and free operation.
8. Operate all electrically operated switches, circuit breakers, and other devices equipped with remote operators (not under load). An auxiliary source of control power may be necessary to accomplish this.
9. Check all relays, meters, and instrumentation to verify that all field installed wiring connections are made properly and that the devices function properly.
10. Current transformers (CTs) supplied for customer use require connection to a metering device load before energizing. Verify that the metering device load is properly connected, including main switchgear connections to remote equipment.
11. All CT circuits supplied by Schneider Electric for customer metering use are shorted for shipment. Remove shorting terminal screws on shorting terminal blocks or jumpers and store in the block.
12. On switchgear containing an electronic trip circuit breaker, set the tripping characteristic curve of the adjustable electronic trip unit per the job requirements, or as outlined in the respective instruction manual.
13. Verify that all grounding connections are correctly made. If the switchgear is used as a service entrance, double check to see that the main bonding jumper is connected.
14. Check all field-installed wiring. Make certain it is clear of all live parts, and when instructed, secured to withstand fault currents.
15. Verify that all control wiring between sections is connected.
16. Vacuum to remove any dust, scrap wire, or other debris.
17. Replace all covers; check for any pinched wires, and close doors. Make certain all enclosure parts are properly aligned and fastened securely.

### CAUTION

#### CONTAMINATION HAZARD

Do not use an air hose to blow out the switchgear. The dust may settle inside relays and overcurrent devices, causing overheating and improper operation.

**Failure to follow this instruction can result in equipment damage.**

## Section 6—Energizing the Switchgear

### **⚠ DANGER**

#### **HAZARD OF ELECTRIC SHOCK, EXPLOSION, OR ARC FLASH**

- Correct short circuit conditions detected during the checkout procedures described in “Section 5—Pre-Energizing Checkout Procedure”, beginning on page 51.
- Qualified electrical personnel must be present when energizing this equipment for the first time.
- Follow the instructions in this section to properly energize the switchgear.

**Failure to follow these instructions will result in death or serious injury.**

1. No load should be on the switchgear when it is energized. Turn off all downstream loads.
2. Energize the switchgear in the following sequence:
  - a. Turn on all control power disconnects before energizing the switchgear. Refer to the record drawings supplied with equipment to see if control power disconnects are supplied.
  - b. Close any open doors and/or covers.
  - c. Close the main device(s).
  - d. Close each branch circuit breaker.
  - e. Proceed to each panelboard and other downstream load.

After all overcurrent protective devices are closed, turn on all loads (for example, lighting circuits, contactors, heaters, and motors).

## Section 7—Maintaining the Switchgear

### **⚠ DANGER**

#### **HAZARD OF ELECTRIC SHOCK, EXPLOSION, OR ARC FLASH**

- Inspect and perform preventive maintenance only on switchgear and equipment to which power has been turned to the OFF position, disconnected, and electrically isolated (unless otherwise specified) so that no accidental contact can be made with energized parts.
- Follow safety related work practices as described in NFPA 70E - Standard for Electrical Safety Requirements for Employee Workplaces and OSHA Standards - 29 CFR Part 1910 Subpart S - Electrical.

**Failure to follow these instructions will result in death or serious injury.**

Periodic maintenance on the switchgear includes cleaning, lubrication, and exercising component parts. The interval between maintenance checks can vary depending upon the amount of usage and environmental conditions of each installation. The maximum recommended inspection interval is one year. This definition for periodic maintenance applies throughout this manual, unless otherwise noted.

Always inspect the switchgear after a fault. (Refer to “Section 8—Adverse Circumstances”, beginning on page 52). Service manuals for the various disconnecting and overcurrent devices mounted in the switchgear are available through Square D Services at 1-888-778-2733.

### Switchgear Inspection Guidelines

In general, the following guidelines may be followed. However, as conditions vary, the maintenance program must also be adapted to provide a long life for the equipment and the electrical system.

Periodic inspection of the equipment will be necessary to establish the conditions to which the switchgear are subjected (see “Ideal Operating Conditions” below, and “Normal Operating Conditions” and “Harsh Operating Conditions” on page 49). Perform inspections and maintenance according to these conditions.

Inspect the equipment immediately after abnormal or stressful operating conditions occur or after the equipment experiences a fault current.

These inspection and maintenance guidelines cover only Square D® brand Power-Zone 4 switchgear. If conditions cannot be established and documented, then the harsh operating condition must be assumed.

These inspection and maintenance guidelines do not warrant any field connections, field modifications, or supersede any maintenance procedures or schedules recommended by component manufacturers. For more information regarding the warranty of this product, refer to “Schneider Electric Conditions of Sale.”

#### Ideal Operating Conditions

When the equipment is operating under the “ideal operating conditions” outlined below, it should be able to operate without maintenance for a period of five years.

##### Environmental

- Ambient room temperature range is 50 °F (10 °C) to 104 °F (40 °C).
- Altitude is less than 6600 ft (2012 m).
- Equipment is located indoors in a climate controlled room (heat/AC).
- Absence of dust or debris either airborne or settled.
- Relative humidity averaging less than 70%.
- Absence of vibrations or seismic activity.

#### Circuit Loading

- Continuous loading (with 100% rated devices) is between 20–80% of the equipment ratings.
- Average loading not exceeding 70% of the equipment rating.
- Only resistive or continuous motor loads, no welding or jogging loads.
- Circuit breaker switching less than 15 cycles annually.
- Maximum of two circuit breaker trips due to overload or fault annually.

#### Equipment Installation

- Torque all busbar joints, lugs, and bolts to their appropriate tightness at installation.
- Securely tighten all control and communications wiring at installation.
- Follow pre-energizing checkout rigorously.

### Normal Operating Conditions

When the equipment is operating under the “normal operating conditions” outlined below, it should be inspected and maintained every 1–3 years, or more frequently, based on the user’s experience.

#### Environmental

- Ambient room temperature is between -22 °F (-30 °C) and 104 °F (40 °C).
- Altitude is less than 6600 ft (2012 m).
- The effect of solar radiation is not significant.

**NOTE:** Refer to the principles outlined in IEEE Standard C37.24-1986 for additional information.

#### Circuit Loading

- Circuit breaker switching is no more than 200 cycles annually.
- Welding or jogging loads represents less than 15% of a circuit and/or equipment loading.

#### Equipment Installation

- Torque all busbar joints, lugs, and bolts to their appropriate tightness at installation.
- Securely tighten all control and communications wiring at installation.
- Follow pre-energizing checkout rigorously.

### Harsh Operating Conditions

When the equipment is operating under the “harsh operating conditions” outlined below, it should be inspected and maintained every 6 months, or more frequently, based on the user’s experience.

#### Environmental

- Ambient room temperature is less than -22 °F (-30 °C) or greater than 104 °F (40 °C).
- Altitude exceeds 6600 ft (2012 m).
- The effect of solar radiation is significant.
- The equipment is exposed to hot and/or humid climate.
- The equipment is exposed to damaging fumes, vapors, steam, salt air, and/or oil vapors.
- The equipment is exposed to seismic shock or abnormal vibrations or tilting.

## General Inspection and Cleaning

### CAUTION

#### CONTAMINATION HAZARD

- Do not use an air hose to blow out the switchgear. The dust may settle inside relays and overcurrent devices, causing overheating and improper operation.
- Do not allow paint, chemicals, or petroleum-based solvents to contact plastics or insulating materials.

**Failure to follow these instructions can result in equipment damage.**

#### Circuit Loading

- The circuit breaker trips frequently due to overloading or fault.
- Circuit breaker switching exceeds 200 times annually.
- Welding loads or jogging loads represent greater than 15% of a circuit's load.

#### Equipment Installation

- Torque all busbar joints, lugs, and bolts to their appropriate tightness at installation.
- Securely tighten all control and communications wiring at installation.
- Follow pre-energizing checkout rigorously.

1. Vacuum the switchgear interior to remove any dirt or dust deposits. Wipe all bus bars, insulators, cables, and so forth, with a clean, dry, lint-free cloth.
2. Check the switchgear interior carefully for moisture, condensation build-up, or signs of any previous wetness. Moisture can cause insulation breakdown and rapid oxidation of current carrying parts. Inspect all conduit entrances and cracks between the enclosure panels for dripping leaks. Condensation in conduits may be a source of moisture and must not be allowed to drip onto live parts or insulating material. Take the necessary steps to eliminate the moisture and seal off all leaks.
3. Inspect the switchgear for any signs of overheating. Discoloration and flaking of insulation or metal parts are indications of overheating.  
**NOTE:** If overheating occurs, be sure that all conditions that caused the overheating have been corrected. Loose or contaminated connections can cause overheating.
4. Check for signs of rodent nesting in the switchgear. If required, use a good exterminating technique in the general area of the switchgear.  
**NOTE:** Do not place or use exterminating substances and chemicals inside the switchgear. Some of these products attract rodents.
5. Carefully inspect all devices for any visibly worn-out, cracked, or missing parts.
6. Open and close circuit breakers several times to verify they are working properly.
7. Verify that all key interlocks and door interlocking provisions are working properly.

## Bus Bar Joints, Lug Terminations, and Insulating Materials

### CAUTION

#### PLATING DAMAGE HAZARD

- Do not sand or remove plating on any bus bar, splice bar, or terminal lug.
- Damage to plating can result in overheating. Replace damaged part. Contact Square D Services at 1-888-778-2733.

**Failure to follow these instructions can result in equipment damage.**

1. Bus bar joints are maintenance-free. Do not retighten them after the pre-energizing checkout procedure is complete.
2. Check all bus bar joints and terminal lugs for any pitting, corrosion, or discoloration resulting from high temperatures or subjection to high fault conditions. If any damage has occurred, replace the bus bars or lugs. If cleaning is required, use Lectra-Clean®, made by CRC.
3. Inspect all insulating materials. Before re-energizing the switchgear, replace insulators having any visible damage (such as cracks).

## Traveling Lifter Inspection and Maintenance Procedures

### Lubrication

Inspect the traveling lifter for wear. These units were developed as quality products for intermittent use, not for continuous use. Frequent use increases lifter wear, but proper lubrication can extend service life.

Perform the following steps to lubricate the traveling lifter assembly.

1. Make sure a good film of lubrication is always present in appropriate places.
2. All wheels and rollers must be lubricated properly with a multi-purpose grease. Brush a high-quality, multi-purpose grease onto the worm gear assembly. Repeat this procedure, as necessary, to maintain a continuous film of grease over the face of these gears.
3. Never operate the winch with the worm gear assembly dry.
4. Lubricate all other points of friction as needed with a high-quality, medium-weight oil. Avoid over saturation that produces oil dripping.

### Inspection and Maintenance

After the equipment has been lubricated, perform the following steps.

- ❑ Inspect all components for cracks, loose parts, and weather or chemical damage.
- ❑ If cracks or strain damage are suspected, remove the unit from service. If cracked components are detected, replace them before returning unit to use.
- ❑ Periodically check for distortion of the traveling lifter. If distortion is found:
  - Verify that the rails and sections are aligned.
  - Verify that the carriage and winch mechanism have been installed correctly.
  - Verify that the cable has been fastened securely to the winch drum.
  - Verify that the gears are well lubricated.

**NOTE:** For normal operation, use a heavy gear lubricant. In very dirty or gritty conditions, it is advisable to use a dry lubricant such as dry graphite to lubricate the gears. Never allow the gears to run dry.

- ❑ If applicable, remove handling means and any obstructions from the top of the unit that could inhibit operation of the traveling lifter.
- ❑ Thoroughly inspect the traveling lifter wire cable. Pay close attention to cable sections, such as parts passing over sheaves or wound on the drum, which are normally hidden during inspection or maintenance procedures. Contact Square D Services at 1-888-Square D (1-888-778-2733) if the cable shows any of the following signs of deterioration:
  - Kinking, crushing, cutting, or unstranding
  - Corroded, cracked, bent, or broken wires
  - Worn end connections
- ❑ Always keep the exterior finish in good condition to protect against corrosive damage. When damage is noticed, remove the finish to bare metal and refinish using a high-quality primer and finish coat.
- ❑ Be certain that all the warning labels are still in place and readable. If the warning labels become unreadable or are destroyed, contact your local Schneider Electric sales office.
- ❑ Do not repair any parts that are worn, cracked, deformed, misaligned, or severely corroded. Repairing parts does not ensure satisfactory or safe performance. Do not substitute other manufacturers' parts.
- ❑ Record all inspections and maintenance performed on the traveling lifter in a maintenance log. See "Section 10—Maintenance Log" on page 55.

## Circuit Breaker Inspection Schedule

The inspection schedule for circuit breakers and trip units should be based on recommendations contained in the circuit breaker and trip units manuals.

## Section 8—Adverse Circumstances

This section includes, but is not limited to, all electrical components of the switchgear.

### **⚠ DANGER**

#### **HAZARD OF ELECTRIC SHOCK, EXPLOSION, OR ARC FLASH**

- Turn off all power supplying the switchgear before cleaning.
- Always use a properly rated voltage sensing device to confirm power is off.
- Before energizing the switchgear, all unused circuit breaker mounting spaces must be filled.

**Failure to follow these instructions will result in death or serious injury.**

**NOTE:** Before attempting to re-energize the switchgear following adverse circumstances, contact Square D Services at 1-888-778-2733 for special instructions.

### Inspection Following a Short Circuit

If a short circuit occurs, make a thorough inspection of the entire system, and verify that no damage to conductors or insulation has occurred. High mechanical and thermal stresses developed by short-circuit currents may damage conductors and insulation. Check the overcurrent protection device that interrupted the short-circuit current for possible arcing damage.

Do not open sealed devices, such as molded case circuit breakers. These devices should be replaced if damaged. Before energizing the switchgear, all unused circuit breaker mounting spaces must be filled.

### Clean-up Following a Short Circuit

The insulating properties of some organic insulating materials may deteriorate during an electrical arc. If so:

1. Remove any soot or debris.
2. Replace carbon-tracked insulation.

### Water-Soaked Switchgear

Do not clean or repair a switchgear that has been exposed to large volumes of water or submerged at any time. Current-carrying parts, insulation systems, and electrical components may be damaged beyond repair. **Do not energize the switchgear.** Contact Square D Field Services.

### Water-Sprayed or Splashed Switchgear (Clean Water Only)

### **⚠ DANGER**

#### **HAZARD OF ELECTRIC SHOCK, EXPLOSION, OR ARC FLASH**

- Turn off all power supplying the switchgear before cleaning.
- Always use a properly rated voltage sensing device to confirm power is off.
- Before energizing the switchgear, all unused circuit breaker mounting spaces must be filled.

**Failure to follow these instructions will result in death or serious injury.**

If the switchgear has been sprayed or splashed with small amounts of clean water, make a thorough inspection of the entire system, and verify that no damage to conductors or insulation has occurred. Do not open sealed devices such as molded case circuit breakers or fuses. These devices should be replaced if damaged.

Inspection and Clean-up of Clean Water Sprayed or Splashed Switchgear

Follow steps 1–10 below only if:

- No signs of physical damage to the equipment are present.
- The switchgear has not been submerged or exposed to water for long periods of time.
- The water that has been in contact with the switchgear has not been contaminated with sewage, chemicals, or other substances that can negatively affect the integrity of the electrical equipment.
- The water that has been in contact with the switchgear has not entered any area of the enclosure that may contain wiring installed as intended and located above any live part. Specifically, inspect for water entering through conduits located above live parts.

If any one or more of these conditions have not been met, contact Square D Services at 1-888-778-2733.

If **ALL** of the conditions listed above have been met, proceed as follows:

1. Turn off all power supplying this equipment before working on or inside the equipment.
2. Always use a properly rated voltage sensing device to confirm power is off.
3. Disconnect and electrically isolate the switchgear so that no contact can be made with energized parts.
4. Wipe off all moisture from the bus bars, insulators, and insulating material with a clean, dry, lint-free cloth. Do **not** use cleaning agents or water displacement sprays.
5. Prepare the switchgear for insulation resistance (megger) testing by disconnecting all line side supply connections and all load side cable connections to isolate the switchgear from the wiring system.
6. Turn all circuit breakers or switches to their ON position. The switchgear must remain completely de-energized.
7. Use a megohmmeter with a capacity of 500–1000 Vdc and apply voltage from:
  - a. Each phase-to-ground with circuit breaker on.
  - b. Phase-to-phase with circuit breaker on.
8. Record resistance values. Refer to “Section 9—Switchgear Insulation Resistance Chart” on page 54.
9. If resistance measurements are less than 0.5 megohm, call Square D Services at 1-888-778-2733 for recommendations.
10. If resistance measurements are greater than 0.5 megohm, the equipment can be energized using the procedures listed in “Section 6—Energizing the Switchgear” on page 47.

<b>⚠ CAUTION</b>
<b>TEST VOLTAGE HAZARD</b>
<ul style="list-style-type: none"><li>• Remove the adjustable rating plug before electrical insulation testing a circuit breaker that has a label stating "Warning: Disconnect Plug Before Dielectric Test".</li><li>• Some Micrologic trip units are not rated for voltages that would occur during electrical resistance insulation testing.</li><li>• Open all control and metering disconnects from the control circuits.</li></ul>
<b>Failure to follow these instructions can result in injury or equipment damage.</b>







**INDEX**

- A**  
anchoring  
  base channels 17  
  non-seismic 17  
  seismic 19
- B**  
base channels 17  
bus compartment  
  bus joints 20  
  installation 20–25  
bus connections  
  splicing the ground bus 21  
  splicing the main through-bus 24–25  
  splicing the neutral bus 22–24
- C**  
cable compartment  
  compression lugs 28  
  conductor restraint 29  
  installation 28–30  
  mechanical lugs 28  
carriage assembly  
  brackets 27, 35  
  installation 36  
  obstruction clearance 36  
  rollers 27, 35  
  torque values 36  
circuit breaker  
  handling 12, 42  
  lifter bars 12, 41  
  safety precautions 9  
  w-frame 41  
  y-frame 41  
circuit breaker lifter bars  
  handling 12  
  operation 42  
  w-frame assembly 41  
  y-frame assembly 41  
conductor restraint 29  
control connections 31  
crane 10, 13
- E**  
equipment  
  safety precautions 9  
  storage 13
- F**  
flex connections 31–32  
floor crane 10, 13  
forklift 12
- G**  
ground bus 21  
grounding and bonding  
  grounded systems 26  
  not service equipment 27  
  service equipment 26  
  ungrounded systems 27
- H**  
handling  
  circuit breaker lifter bars 12  
  circuit breakers 12  
  crane 10, 13  
  forklift 12  
  traveling lifter 13
- I**  
inspection  
  circuit breakers 51  
  switchgear operating conditions 48–49  
  traveling lifter 51  
  trip units 51  
installation  
  bus joints preparation 20  
  conductor restraint 29  
  control connections 30  
  equipment positioning 15  
  flex connections 31–32  
  grounding and bonding 26–27  
  join wiring compartments 16  
  main power connections 28  
  main through-bus laminations 24  
  neutral bus laminations 23  
  non-seismic anchoring 17  
  seismic anchoring 19  
  splicing the ground bus 21  
  splicing the main through-bus 24  
  splicing the neutral bus 22  
  transformer connections 32  
  traveling lifter 39  
  vertical sections lineup 14
- L**  
lifting straps 10
- M**  
main through-bus 24–25  
maintenance  
  circuit breakers 51  
  switchgear operating conditions 48–49  
  traveling lifter 51  
  trip units 51
- N**  
neutral bus  
  laminations 23  
  splicing 22
- O**  
overhead crane 10
- P**  
power connections 28–31
- R**  
rail-mounted traveling lifter  
  characteristics 8  
rails  
  alignment 34  
  front 34  
  obstruction requirements 34  
  rear 34
- S**  
safety precautions  
  overview 9  
Schneider Electric  
  equipment shortage and/or damage  
  during shipping 10  
storage  
  circuit breaker lifter bar 13  
  circuit breakers 13  
  switchgear 13  
  traveling lifter 13
- T**  
tables  
  circuit breaker lifter bars 41  
  conductor restraint requirements 29  
  main through-bus laminations per phase  
  25–26  
  transformer flex connections 32  
torque values  
  carriage assembly 36  
  flex connectors 31  
  ground bus 21  
  main through-bus 25  
  neutral bus 23  
  rail bolts 35  
  winch mechanism 38  
transformer connections 32  
traveling lifter  
  carriage assembly installation 36  
  handling 13  
  hooked crank 40  
  inspection 51  
  installation 39  
  maintenance 51  
  operational testing 39–40  
  rail alignment 34  
  winch mechanism installation 37–38
- W**  
winch mechanism  
  cable 38  
  drum 38  
  drum hook 38  
  gear lubrication 37  
  installation 37–38  
  lifting hook 38  
  rollers 38  
  stop brackets 38  
  torque values 38  
  weight 38  
wiring compartments  
  connect controls and wiring 30  
  covers 16  
  splice assembly 16





**Power-Zone<sup>®</sup> 4 Low Voltage, Metal-Enclosed Switchgear with Masterpact<sup>®</sup> Low Voltage Power Circuit Breakers  
Instruction Bulletin**

**Schneider Electric USA**

8821 Garners Ferry Road  
Hopkins, SC 29061 USA  
1-888-SquareD  
(1-888-778-2733)  
[www.us.SquareD.com](http://www.us.SquareD.com)

Electrical equipment should be installed, operated, serviced, and maintained only by qualified personnel. No responsibility is assumed by Schneider Electric for any consequences arising out of the use of this material.

80298-002-06 © 1999–2007 Schneider Electric All Rights Reserved  
Replaces 80298-002-05, 12/2003; 80298-035-04, 03/2004; 80298-033-04, 04/2004