

Communication Drivers

Installation manual

07/2008 eng

Table of Contents



	Safety Information	7
	About the Book	9
Chapter 1	Driver Installation	11
	At a Glance	11
	Driver Installation	12
	The drivers and Unity Pro	15
Chapter 2	Modbus driver	17
	At a Glance	17
	Configuration of the Modbus Driver	18
	Driver configuration screen	19
	Driver Control Screen	21
	Driver Debug Screen	23
	Information Screen	25
	How to configure the Modbus modem with Windows	26
Chapter 3	Uni-Telway Driver for Serial Port	31
	At a Glance	31
	Driver Configuration Screens	32
	How to Configure the Driver	36
Chapter 4	PLC USB driver	39
	At a Glance	39
	Finalizing the Installation	40
	State of the USB link	42
Chapter 5	TSX PCX 3030 / TSX C USB 485 / TSX C USB 232 Cable Drivers	45
	At a Glance	45
	How to install the drivers for TSX PCX 3030 / TSX C USB 485 / TSX C USB 232 cables	46
	Configuration screens for TSX PCX 3030 / TSX C USB 232 / TSX C USB 485 cable drivers	52

Chapter 6	XIP Driver on TCP/IP	55
	At a Glance	55
	Driver Configuration Screen	56
	How to Configure the Driver	59
Chapter 7	FIP Driver for TSX C USB FIP Card	63
	At a Glance	63
	Finalizing Installation	64
	Driver Configuration Screen	66
Chapter 8	PCIWAY driver for Atrium TSX PCI 57 xxx processors	67
	At a Glance	67
	Driver Configuration Screen	68
	How to Adjust the Parameters of the TSX PCI 57 xxx Card	70
Chapter 9	Drivers Manager	73
	At a Glance	73
	Management of X-Way drivers	74
	X-Way addressing modes	79
Chapter 10	Troubleshooting	83
	At a Glance	83
	Installation Troubleshooting	84
	Configuration Troubleshooting	86
Appendices	87
	At a glance	87
Appendix A	Ethway Driver	89
	At a Glance	89
	How to Install the Driver	90
	Driver Configuration Tool	92
Appendix B	FIP Driver for TSX FPP 20 Card	95
	At a Glance	95
	Driver configuration screen	96
	Finalizing installation	97
Appendix C	FIP Driver for TSX FPC 10 ISA Card	99
	At a Glance	99
	Finalizing the installation of the TSX FPC 10 Card	100
	How to Select the Hardware Type	101
	How to Configure Hardware Parameters	104
	How to Adjust the TSX FPC 10 ISA Card Parameters	107
	Driver configuration screen	109

Appendix D	ISAWAY driver for Atrium TPCX 57 processors	111
	At a Glance	111
	Finalizing the installation	112
	How to select the hardware type	113
	How to configure hardware parameters	116
	How to adjust the ISA TPCX 57 card parameters	119
	Configuration of ISAWAY driver	121
Appendix E	Uni-Telway driver for TSX SCP 114 Card	127
	At a Glance	127
	Driver Configuration Screens	128
	Finalizing installation	130
Index		131

Safety Information

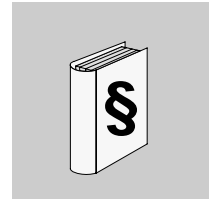

Important Information

NOTICE

Read these instructions carefully, and look at the equipment to become familiar with the device before trying to install, operate, or maintain it. The following special messages may appear throughout this documentation or on the equipment to warn of potential hazards or to call attention to information that clarifies or simplifies a procedure.



The addition of this symbol to a Danger or Warning safety label indicates that an electrical hazard exists, which will result in personal injury if the instructions are not followed.



This is the safety alert symbol. It is used to alert you to potential personal injury hazards. Obey all safety messages that follow this symbol to avoid possible injury or death.

DANGER

DANGER indicates an imminently hazardous situation, which, if not avoided, **will result** in death or serious injury.

WARNING

WARNING indicates a potentially hazardous situation, which, if not avoided, **can result** in death, serious injury, or equipment damage.

CAUTION

CAUTION indicates a potentially hazardous situation, which, if not avoided, **can result** in injury or equipment damage.

PLEASE NOTE

Electrical equipment should be installed, operated, serviced, and maintained only by qualified personnel. No responsibility is assumed by Schneider Electric for any consequences arising out of the use of this material.

© 2008 Schneider Electric. All Rights Reserved.

About the Book

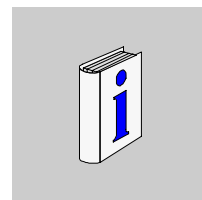

At a Glance

Document Scope This document details the installation and configuration of communication drivers for Windows XP Professional Edition and Windows Vista Business Edition 32.

Operating System Compatibility Table.

Protocol / Hardware type	Windows XP Professional Edition	Windows Vista Business Edition 32
ETHWAY - Ethernet	Yes	No
FIP - FPC10 ISA Card	Yes	No
FIP - FPP20 PCMCIA Card	Yes	No
FIP - CUSBFIP Adapter	Yes	Yes
ISAWAY - PCX57 ISA Card	Yes	No
MODBUS Serial - Port COM	Yes	Yes
PCIWAY - Atrium TPCI57 PCI Card	Yes	Yes
UNI-TELWAY - Port COM	Yes	Yes
UNI-TELWAY - SCP114 PCMCIA Card	Yes	No
USB for High End PLC	Yes	Yes
XIP - XWAY on TCP/IP	Yes	Yes

Validity Note

The data and illustrations found in this documentation are not binding. We reserve the right to modify our products in line with our policy of continuous product development.

The information in this document is subject to change without notice and should not be construed as a commitment by Schneider Electric.

Product Related Warnings

Schneider Electric assumes no responsibility for any errors that may appear in this document. If you have any suggestions for improvements or amendments or have found errors in this publication, please notify us.

No part of this document may be reproduced in any form or by any means, electronic or mechanical, including photocopying, without express written permission of Schneider Electric.

All pertinent state, regional, and local safety regulations must be observed when installing and using this product.

For reasons of safety and to ensure compliance with documented system data, only the manufacturer should perform repairs to components.

When controllers are used for applications with technical safety requirements, please follow the relevant instructions.

Failure to observe this product related warning can result in injury or equipment damage.

User Comments

We welcome your comments about this document. You can reach us by e-mail at techpub@schneider-electric.com

Driver Installation



At a Glance

Subject of this Chapter

This chapter describes how to install the drivers. The installation procedure is the same for all drivers, except for the Ethway driver and the TSX PCX 3030 / TSX C USB 485 / TSX C USB 232 cable driver. Refer to the relevant chapters on those drivers for specific installation instructions.

What's in this Chapter?

This chapter contains the following topics:

Topic	Page
Driver Installation	12
The drivers and Unity Pro	15

Driver Installation



At a Glance

This is the procedure to install the drivers contained on the CD-ROM using Windows XP Professional Edition or Windows Vista Business Edition 32.

The Ethway driver and the TSX PCX 3030 / TSX C USB 485 / TSX C USB 232 cable driver require specific installation procedures. Refer to corresponding driver chapters for installation instructions.

Procedure

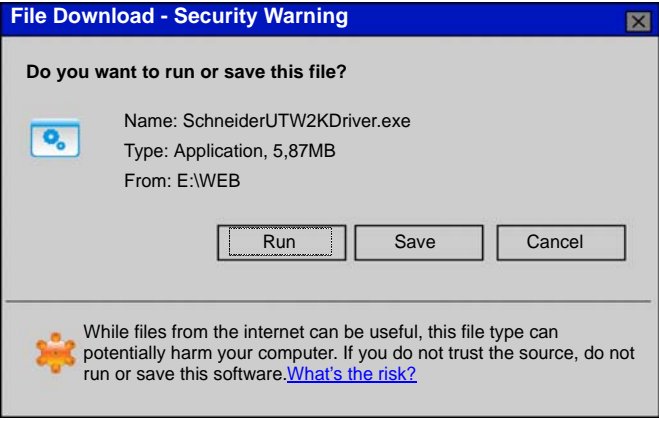
The following procedure describes how to install a driver using the supplied CD-ROM. Example screens from Uni-telway drivers are used to illustrate the procedure. The screens shown may appear different according to the driver you are installing.

Step	Description
1	<p>Insert the CD-ROM in the CD-ROM drive.</p> <p>Result: the _Installdrivers.htm file launches automatically.</p> <p>If not: explore the CD content by double clicking on your CD-ROM drive in My Computer window. Launch the _Installdrivers.htm file by a double click.</p>
2	<p>Choose the driver you wish to install and click on the link of the driver according to the operating system currently running on your computer.</p> <p>Result: the Downloading files dialog box appears:</p> 
3	<p>Choose Run.</p> <p>Result: the Safety Warning dialog box appears:</p> 
4	<p>Click RUN to confirm your choice.</p> <p>Result: the Driver Setup window appears.</p> <p>Follow the instructions displayed in Windows Installation Wizard</p>

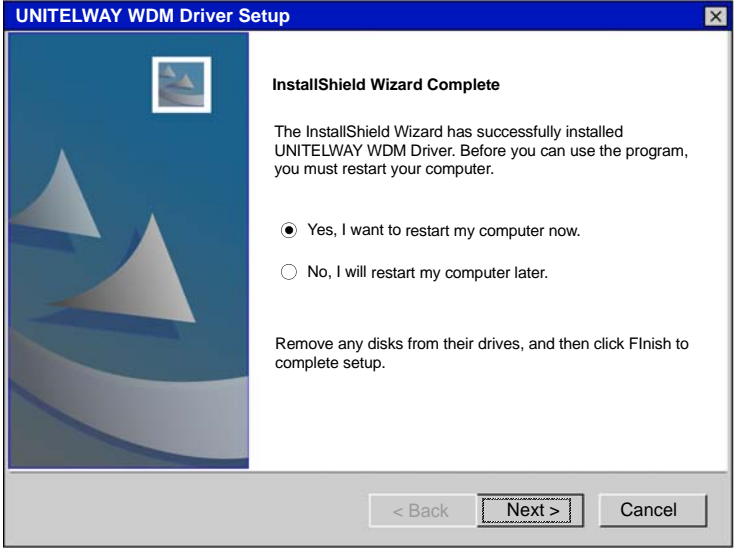
Step	Description
5	<p>Click Next to go ahead with the installation.</p> <p>Result: The driver installation is run. Another driver setup window may appear, click Install.</p>
6	<p>Once the installation has been run, a driver configuration window appears.</p> <p>To configure the installed driver now, refer to the specific chapter for the driver you are currently installing.</p>
7	<p>Once the driver configuration is done, the Driver Setup window appears to restart your computer.</p> <p>Choose Yes if you are done installing drivers, this will reboot your computer. Choose No if you need to install more drivers and repeat the installation procedure from Step 2:</p> 

The drivers and Unity Pro

Precautions

To ensure correct operation of the drivers using the Unity Pro software range you should install or reinstall the drivers using the CD-ROM version \geq V2.0.

Drivers that normally operate using the Unity Pro software range should also be installed using Windows XP Professional Edition or Windows Vista Business Edition 32.

Modbus driver

2

At a Glance

Subject of this Chapter

This chapter describes Modbus driver configuration.

Driver Installation

For installation information, see the Driver Installation Chapter (see *Driver Installation*, p. 11)

What's in this Chapter?

This chapter contains the following topics:

Topic	Page
Configuration of the Modbus Driver	18
Driver configuration screen	19
Driver Control Screen	21
Driver Debug Screen	23
Information Screen	25
How to configure the Modbus modem with Windows	26

Configuration of the Modbus Driver

Access to the Configuration Tool

The configuration tool can be accessed from the taskbar: **Start** → **Settings** → **Control Panel** → **Driver Manager** see Driver Manager Chapter (see *Drivers Manager*, p. 73).

Select the **MODBUS SERIAL Driver** tab to display the following window:

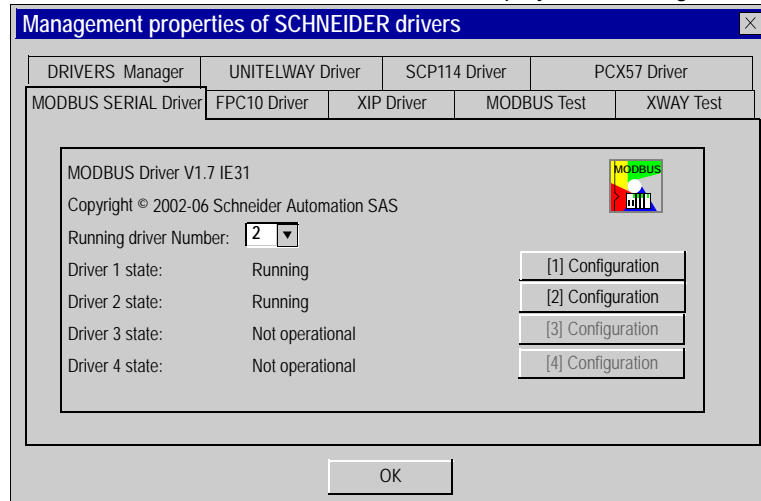

This window enables you to:

- display the driver version installed,
- select the number of drivers to activate,
- display the status of each driver,
- access the configuration (see *Driver configuration screen*, p. 19) of each driver.

Driver configuration screen

At a Glance

This chapter describes Modbus driver for Serial Port configuration.

The configuration tool is accessible from the Windows taskbar: **Start** → **Settings** → **Control Panel** → **Driver Manager**, then choose the **Modbus Serial Driver** tab and select one of the **Configuration** buttons corresponding to the four drivers.

Illustration

The configuration screen dedicated to the Modbus driver looks like this:

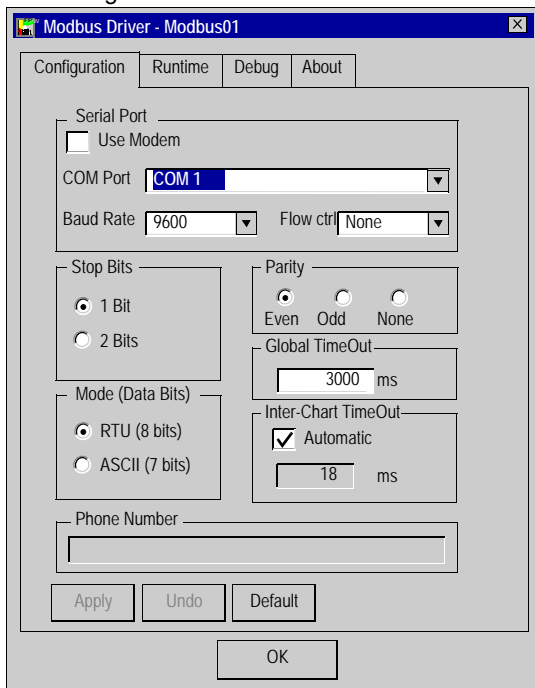

Description

This table describes the different areas which make up the configuration screen:

Area	Element
Serial Port	<p>If the Use Modem box is checked the list of all the modems configured on the PC is displayed in the Modem area (instead of COM Port. To configure the modem in Windows operating system refer to the page of configuration of the modem with Windows (see <i>At a glance</i>, p. 26).</p> <p>COM Port or Modem: provides a choice for the communication port to be used, by default COM1 or the modem to be used.</p> <p>Baud rate: provides a choice for transmission speed between 300 bits per second and 19200 bits per second, by default 9600 Bd.</p> <p>Flow ctrl: selects the flow control of the serial port (except for modem communication).</p>
Stop bits	Allows entry of the number of stop bits used for communication, by default 1 stop bit.
Parity	<p>Is used to set whether a parity bit is added or not, as well as its type, such as:</p> <ul style="list-style-type: none"> ● Even, for even parity (default selection), ● Odd, for odd parity, ● None, for no parity
Global TimeOut	Allows Reception Time-Out to be defined (in milliseconds) while the driver is waiting for the response from the polled Modbus slave.
Inter-Char TimeOut	<p>Allows quiet time to be defined (in milliseconds), permitting detection of a Modbus end delimiter.</p> <p>If the Automatic box is checked, the value is automatically calculated according to speed (Baud Rate).</p>
Mode (Data Bits)	<p>RTU: the characters are coded on 8 bits in binary. This mode is the default mode.</p> <p>ASCII: the characters are coded on 7 bits in ASCII.</p>
Phone number	Number to dial when the communication port is connected to a modem.
Apply button	Saves the configuration.
Undo button	Cancels the latest modifications.
Default button	Sets parameters for the different fields with default values.
OK button	Allows configuration parameters to be acknowledged, and represents the window by an icon.

Modbus Instances

Once installed, configure the Modbus driver and reboot the computer. All Modbus instances that are activated in the driver manager are initialized.

For each Modbus instance configured a corresponding icon appears in the task bar.

Driver Control Screen

At a Glance

This screen is used to view information concerning driver operation.

The refreshment period for this information is defined in a driver screen. See *Driver Debug Screen*, p. 23.

Illustration

You can access the control screen dedicated to the Modbus driver by selecting the **Runtime** tab in the **Driver Configuration** screen:

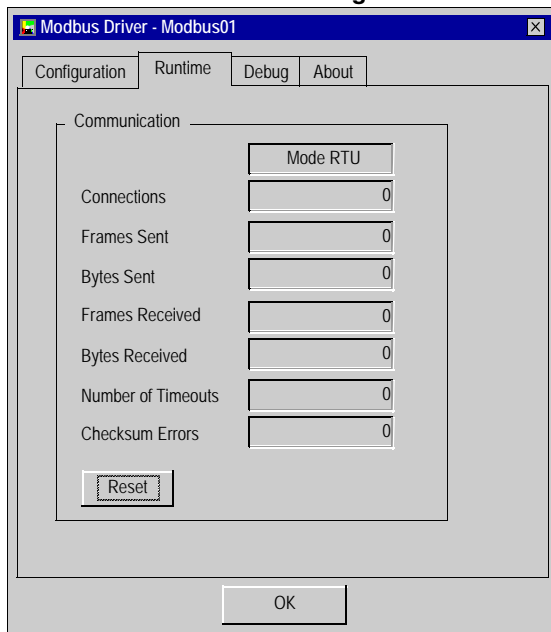

Description

This table describes the different information concerning driver operation:

Element	Description
Mode	Displays the driver operating mode: <ul style="list-style-type: none">● RTU Mode,● ASCII Mode.
Connections	Contains the number of clients using the driver
Frames Sent	Contains the number of frames sent since the last Reset.
Bytes Sent	Contains the number of bytes sent since the last Reset.
Frames Received	Contains the number of frames received since the last Reset.
Bytes Received	Contains the number of bytes received since the last Reset.
Number of TimeOut	Contains the number of Time-Outs reached; the value is defined in the "Global Delay" configuration screen.
Checksum Errors	Contains the number of checksum errors detected.
Reset	This button is used to reset the different counters in the control screen to 0.
OK	This button allows the window to be represented as an icon.

Driver Debug Screen

At a Glance

This screen is used to deactivate the saving of certain operations carried out by the communication driver in a trace file.

Illustration

You can access the debug screen dedicated to the Modbus driver by selecting the **Debug** tab in the **Driver Configuration** screen:

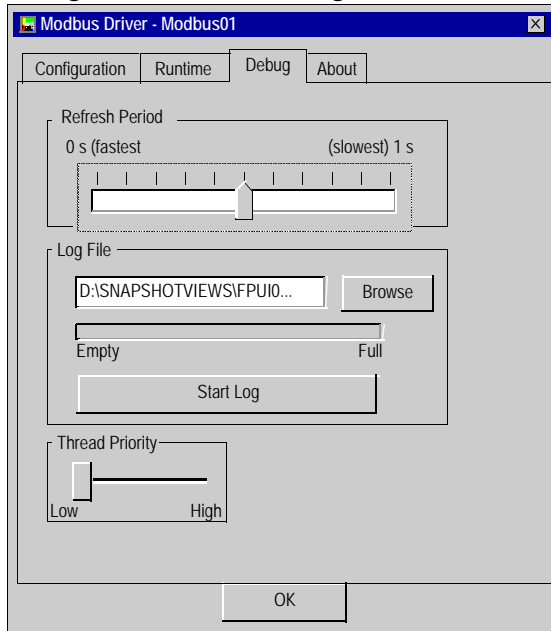

Description

This table describes the different areas which make up the debug screen:

Area	Description
Refresh Period	Allows the screen refreshing period for the driver control screen to be defined within a range of 0s to 1s.
Log File	This area contains: <ul style="list-style-type: none">● the description of the path where the trace file has been saved,● a bar graph showing the fill level of the trace file.● a button to start or stop saving in the trace file.
Thread Priority	Adjusts the priority of the driver with regard to other tasks executed in Windows. The default setting is "Low" .
OK	This button allows the window to be represented as an icon.

Information Screen

At a Glance

This screen provides general information on the communication driver and on the operating system installed.

Illustration

You can access the information screen dedicated to the Modbus driver by selecting the **About** tab in the **Driver Configuration** screen:

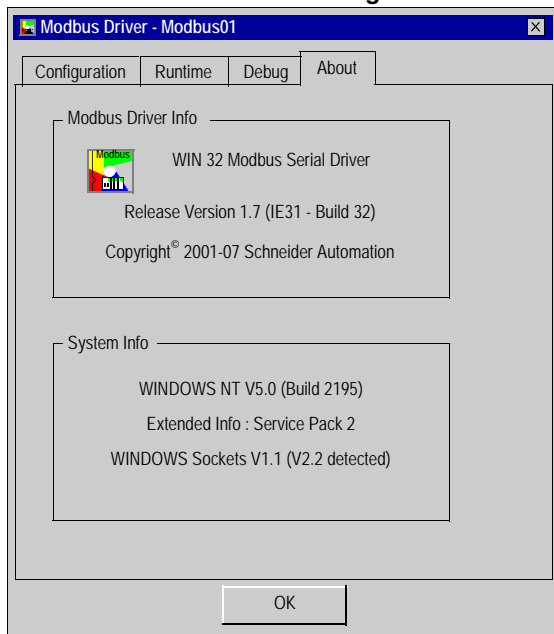

Description

This table describes the different areas which make up the information screen:

Area	Element
Modbus Driver Info	This area contains: <ul style="list-style-type: none"> the driver version, the Schneider Electric Copyright.
System Info	This area contains: <ul style="list-style-type: none"> the Windows operating system version, additional information, the Winsock interface version.
OK	This button allows the window to be represented as an icon.

How to configure the Modbus modem with Windows

At a glance

This section explains how to configure the Modbus modem with Windows Operating System when the check button **Use Modem** is selected in the driver configuration screen (see *Driver configuration screen, p. 19*).

Procedure

In the Windows control panel, select the icon **Phone and Modem options**:

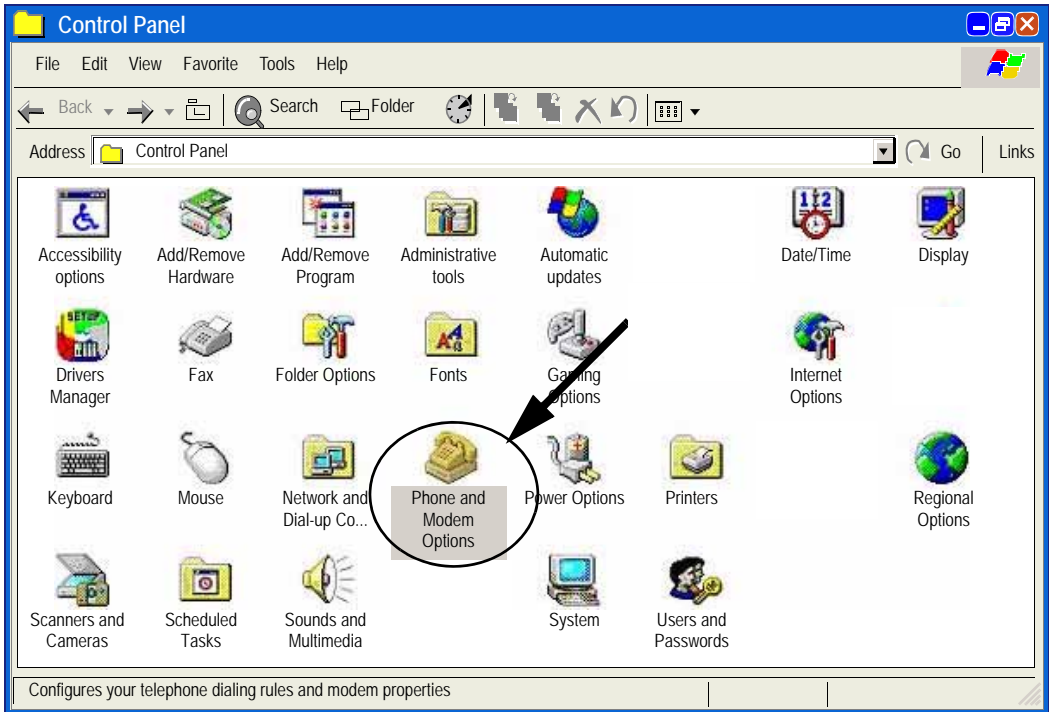

Open the tab **Modems**, then select the modem to configure from the list, and click on the **Properties** button:

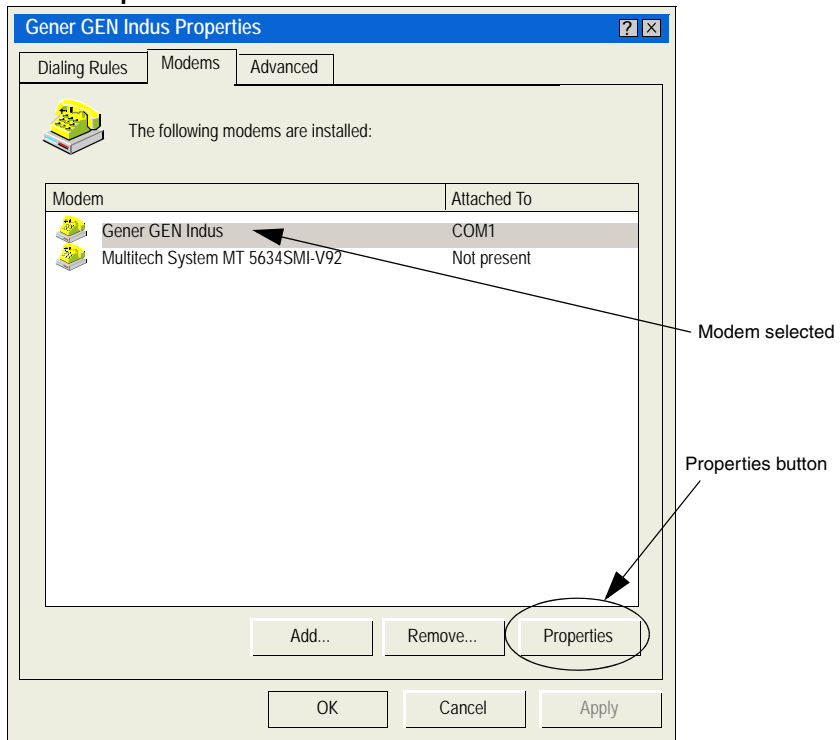

In the properties screen, enter (if needed) the Hayes initialization string of the modem, then click on **Change Default Preferences** button:

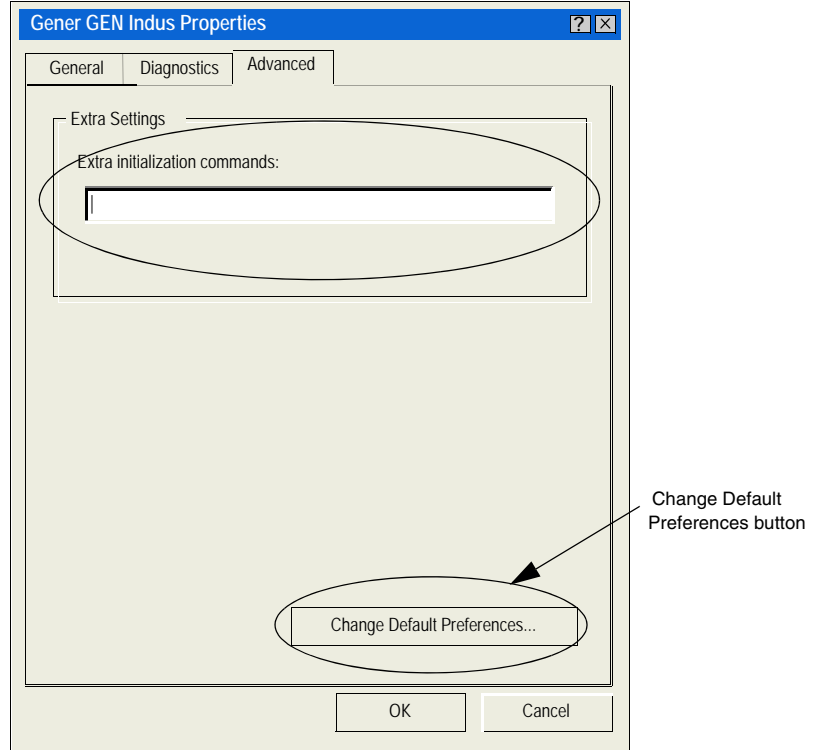

In the **Default preferences** screen, enter the same speed as the modbus driver, uncheck the disconnection option, then click on the **Advanced** tab:

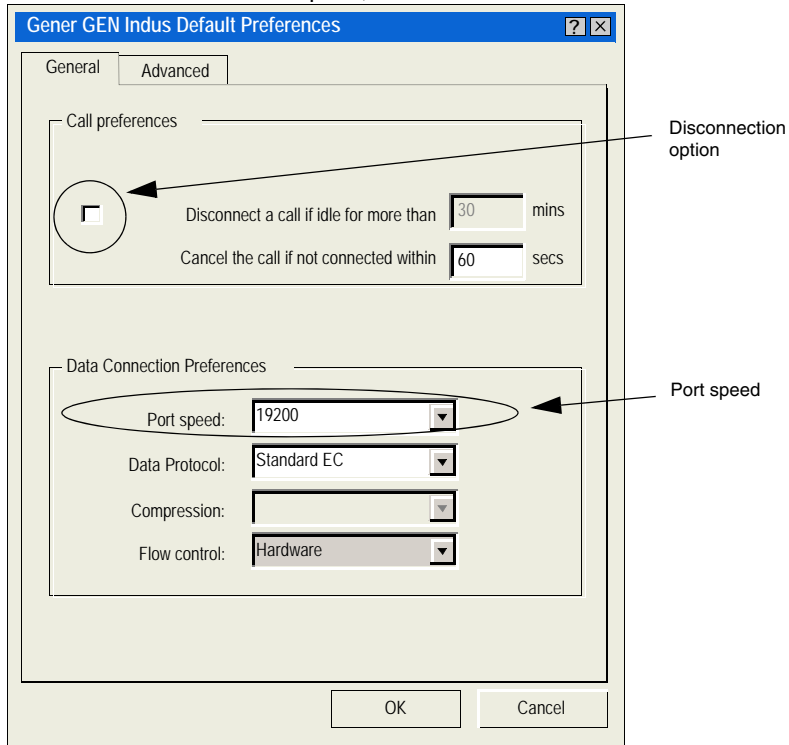

Enter the same parameters as those entered in the driver Modbus configuration screen. Then click on **OK** button to validate the modifications:

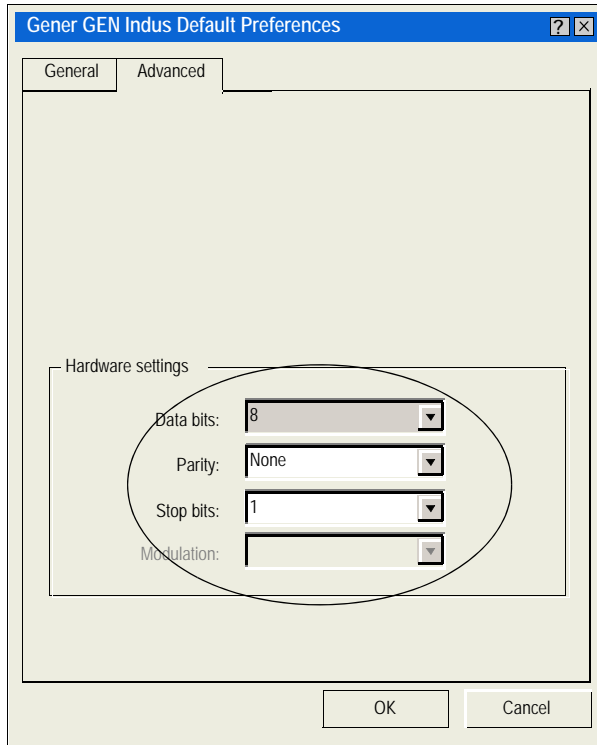

The modem is now configured to use with Modbus driver.

Uni-Telway Driver for Serial Port

3

At a Glance

Subject of this Chapter

This chapter describes configuration of the Uni-Telway driver communicating in slave mode on the serial port with a remote device.

Driver Installation

For installation information, see the Driver Installation Chapter (see *Driver Installation*, p. 11)

What's in this Chapter?

This chapter contains the following topics:

Topic	Page
Driver Configuration Screens	32
How to Configure the Driver	36

Driver Configuration Screens

At a Glance

The configuration tool is used to link a driver configuration profile to a remote device that communicates with the station.

The configuration tool can be accessed from the taskbar: **Start** → **Settings** → **Control panel** → **Driver Manager** see Driver Manager Chapter (see *Drivers Manager, p. 73*)

Select the tab corresponding to the driver to be configured in the **Driver Manager** window.

Illustration

The screen dedicated to the Uni-Telway driver looks like this:

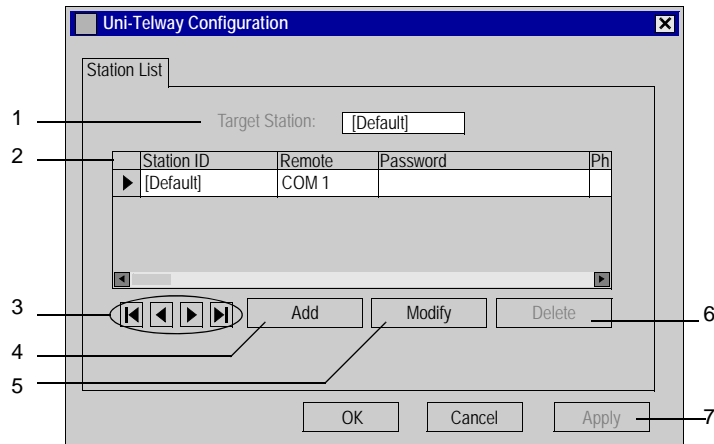

Description

This table describes the different areas which make up the configuration screen:

Number	Element
1	This field is used to display the active profile.
2	This list is used to display the driver profile associated with each remote device.
3	These buttons are used to select the driver profile.
4	This button is used to add new profiles to the list.
5	This button is used to modify the profile of the driver selected from the list.
6	This button is used to remove a profile from the list.
7	This button is used to make the profile selected with the cursor active.

Uni-Telway Parameters

The parameters are presented in the **Parameter of the station** window.

This window is accessed by clicking **Add** on the Unitelway configuration screen (see *Illustration, p. 32*):

Description

This table describes the different areas which make up the Uni-Telway tab in the Parameter of the station window:

Element	Description
Station ID	The Station ID is used to name the remote device associated with the driver configuration.
Com Port	The Port Com is used to select the communication port used.
Uni-Telway Slave address	The Uni-telway Slave Address window is used to enter: <ul style="list-style-type: none"> the standard slave address of the driver, the number of slave addresses used by the driver.
Communication Modem	The Communication Modem window is useful when the local station is communicating via a modem. In this case, this window is used to enter: <ul style="list-style-type: none"> the HAYES string to be sent to the modem in order to initialize it, the call number of the remote device, the password to be sent to the remote device, if it has been configured with a list of callers with passwords (e.g. TSX MDM 10 card configured with passwords).

Link Parameters Select the tab corresponding to **Link parameters** in the **Parameters of the station** window.

The parameters are presented in the following manner:

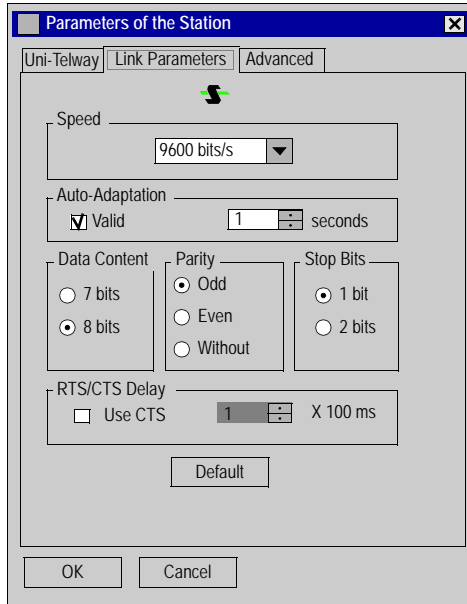

Description

This tab is used to configure the parameters linked to transmission:

Element	Description
Speed	This area enables to set transmission speed of between 300 bits per second and 115,200 bits per second.
Auto-Adaptation	self-adaptation of speed (time during which the driver tries to connect at a given speed).
Data Content	The Data Content specifies the size of the data exchanged over the line.
Parity	This area is used to set whether a parity bit is added or not, as well as its type
Stop Bits	This area is used to enter the number of stop bits used for communication.
RTS/CTS Delay	This area enables the CTS signal to be used in the event of multidrop communication.
Default	The Default button is used to reset all these parameters to their default value.

Advanced Parameters

Select the tab corresponding to **Advanced parameters** in the **Parameters of the station** window.

The advanced parameters are presented in the following manner:

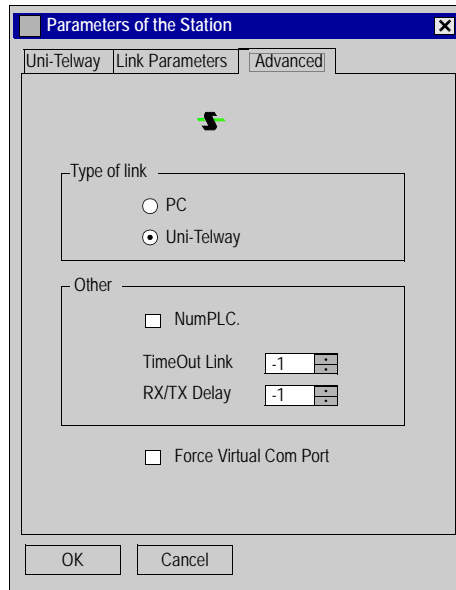

Description

This tab is used to configure the link type:

Element	Description
PC	Uses the driver to connect to a series 7 PLC terminal port.
Uni-Telway	Default value, uses the driver to communicate in Uni-Telway.
Num PLC	Uses the driver to connect to Num PLCs <ul style="list-style-type: none"> ● Timeout Link: By default set to -1; is used to set the maximum time for detecting the right transmission speed. ● RX/TX Delay: By default set to -1; is used to extend the return time (if the station is too fast)
Force Virtual Com Port	Must be checked if the Unit-Telway driver uses a virtual communication port except for use with the TSX PCX 0303 / TSXCUSB485 / TSXCUSB232 cables.

How to Configure the Driver

At a Glance

During driver installation, a default profile is proposed. This profile can be modified or a new one created.

How to Create a New Profile

From the driver Uni-telway configuration screen (see *Illustration, p. 32*):

Step	Action
1	Click on the Add... button. see <i>Uni-Telway Parameters, p. 33</i> .
2	Enter station name.
3	Select COM port .
4	Define the driver slave address.
5	If the driver uses a modem to communicate, select the Use modem box and enter the different fields associated with it.
6	Select the Link parameters (see <i>Link Parameters, p. 34</i>) tab.
7	Configure the transmission parameters according to the remote device (baud rate, parity, data bits, etc.).
8	If the driver requires specific configuration, click on the Advanced (see <i>Advanced Parameters, p. 35</i>) tab and configure the parameters according to the remote device.
9	Accept the configuration by clicking on Ok . Result: the new configuration appears in the list.

How to Modify a Profile

From the Uni-telway configuration screen (see *Illustration, p. 32*):

Step	Action
1	Select a configuration profile from the list. Result: the cursor moves to the selected line.
2	Click on the Modify button; see <i>Uni-Telway Parameters, p. 33</i> .
3	Modify the parameters according to the remote device.
4	Select the Link parameters (see <i>Link Parameters, p. 34</i>) tab and modify the transmission parameters according to the remote device (speed, parity, data, etc.).
5	If the driver requires specific configuration, click on the Advanced (see <i>Advanced Parameters, p. 35</i>) tab and modify the parameters according to the remote device.
6	Accept the configuration by clicking on Ok . Result: the new configuration appears in the list.

How to Remove a Profile

From the Uni-telway configuration screen (see *Illustration, p. 32*):

Step	Action
1	Select a configuration profile from the list. Result: the cursor moves to the selected line.
2	Click on Delete .
3	Press the Yes button to confirm your choice. Result: the configuration is removed from the list.

How to Activate a Profile

From the Uni-telway configuration screen (see *Illustration, p. 32*):

Step	Action
1	Select a profile from the list. Result: the cursor moves to the selected line.
2	Click on the Apply button.

PLC USB driver



At a Glance

Subject of this Chapter

This chapter describes how to finalize the installation and to verify the state of the PLC USB driver.

The PLC USB driver is used to connect with PLCs that are equipped with USB ports (such as Premium and Quantum)

Driver installation

For installation information, see the Driver Installation Chapter (see *Driver Installation*, p. 11)

What's in this Chapter?

This chapter contains the following topics:

Topic	Page
Finalizing the Installation	40
State of the USB link	42

Finalizing the Installation

Procedure

After rebooting the PC you will have to configure the USB driver. The USB cable must be connected to the PLC, and then Windows will detect the PLC and install the driver.

Perform the following actions:

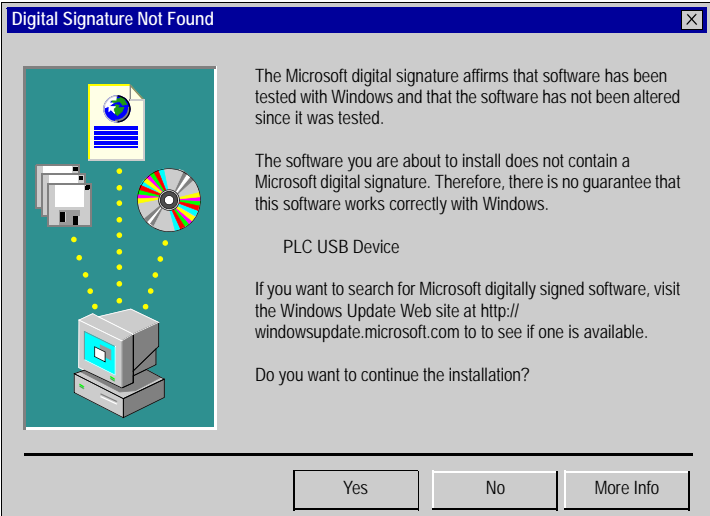
Step	Action
1	<p>The following screen will be displayed:</p> 
2	<p>Click on YES:</p> 

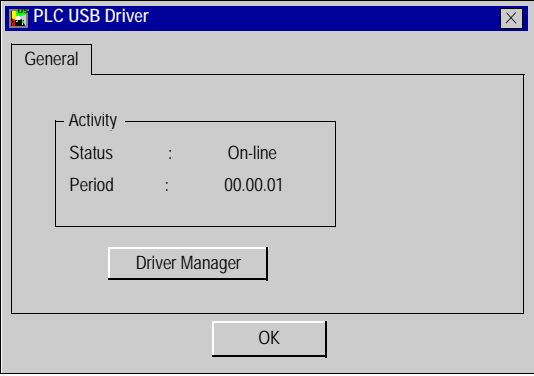
Step	Action
3	<p data-bbox="445 203 1211 251">An icon is displayed in the task bar. Double clicking on it when the USB link with the PLC is operational calls up the window:</p>  <p data-bbox="445 646 1211 698">Clicking on "Driver Manager" launches the tool. Clicking on "OK" makes an icon appear in the task bar.</p>

State of the USB link

At a Glance

A window showing the state of the USB link can be accessed from the taskbar:

Start → Settings → Control Panel → Driver Manager

With Windows XP Professional Edition, select the **PLC USB Driver** tab to display the following window:

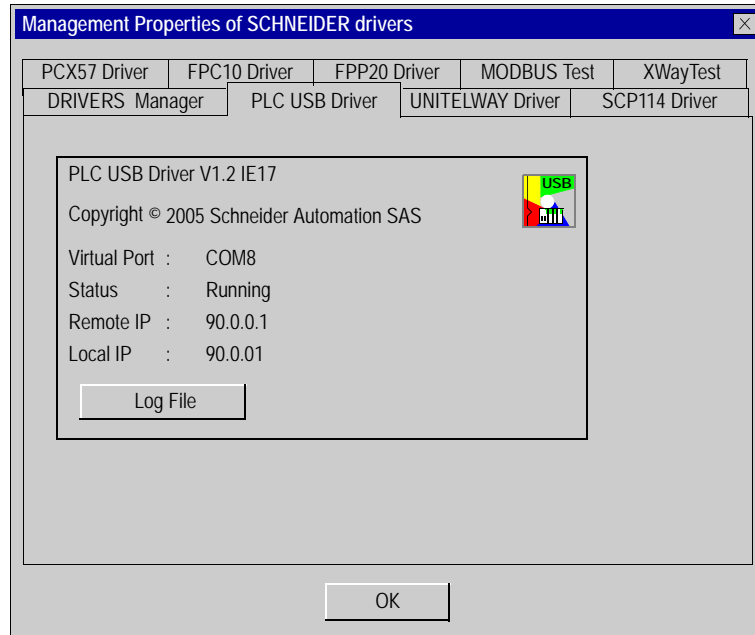

Description for Windows XP Professional Edition:

Field	Description
Virtual Port	Name of the COM port used by the driver.
Status	Contains: <ul style="list-style-type: none"> ● "Running" if the driver is operating. ● "Not operational" if the driver is not operating. ● "Disconnected" if the USB cable is not connected.
Remote IP\Local IP	IP addresses used by the PC and PLC to communicate.
Log File	Button allowing access to a *.log file containing connection/ disconnection events on the USB line.

With Windows Vista Business Edition 32, select the **PLC USB Driver** tab to display the following window:

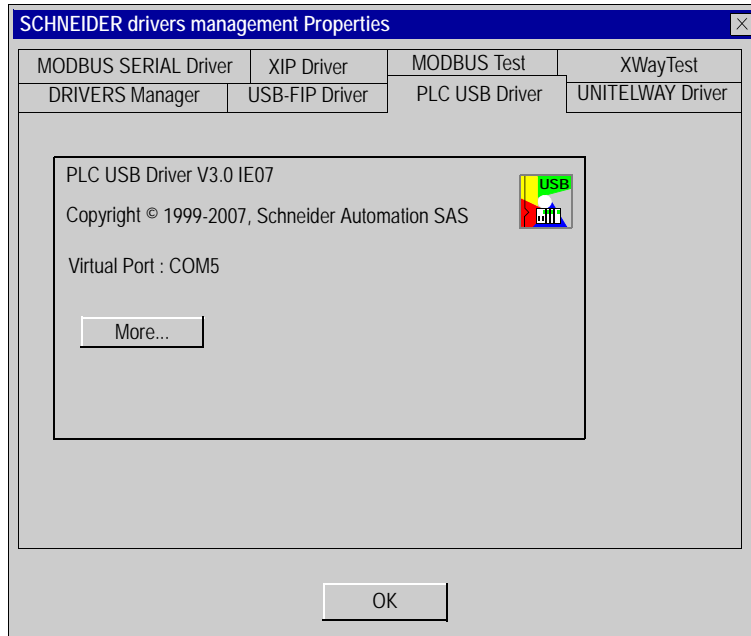

To see Diagnostic (Screen below) press the **more...** button.

With Windows Vista Business Edition 32, select the **PLC USB Driver diagnostic**:

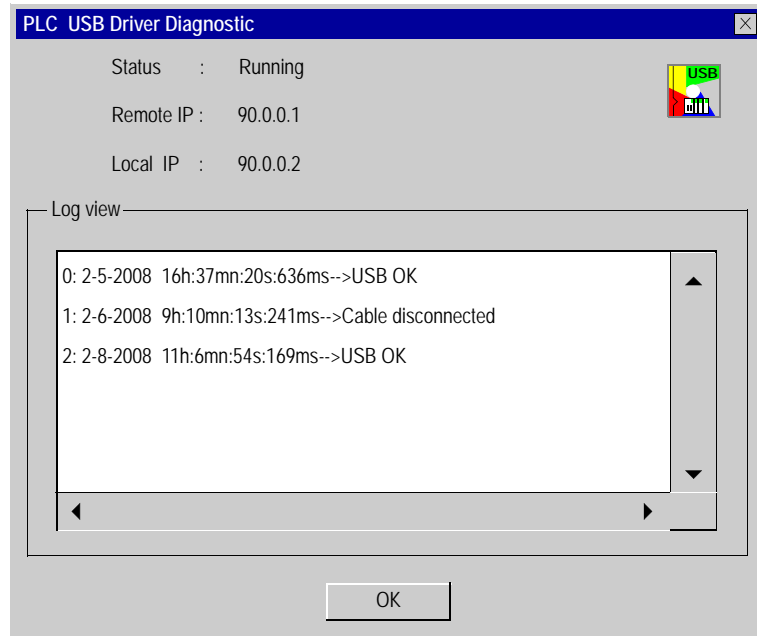

Description for Windows Vista Business Edition 32:

Field	Description
Virtual Port	Name of the COM port used by the driver.
Status	Contains: <ul style="list-style-type: none"> ● "Running" if the driver is operating. ● "Not operational" if the driver is not operating. ● "Disconnected" if the USB cable is not connected.
Remote IP\Local IP	IP addresses used by the PC and PLC to communicate.
Log View	Button allowing access to a *.log View containing connection/ disconnection events on the USB line.

TSX PCX 3030 / TSX C USB 485 / TSX C USB 232 Cable Drivers

5

At a Glance

Subject of this Chapter

This chapter describes the installation and configuration of drivers for the TSX PCX 3030, TSX C USB 232, and TSX C USB 485 cables with Windows XP Professional Edition and Windows Vista Business Edition 32. These cables are USB/RS-485 or RS232 Serial link converters.

What's in this Chapter?

This chapter contains the following topics:

Topic	Page
How to install the drivers for TSX PCX 3030 / TSX C USB 485 / TSX C USB 232 cables	46
Configuration screens for TSX PCX 3030 / TSX C USB 232 / TSX C USB 485 cable drivers.	52

How to install the drivers for TSX PCX 3030 / TSX C USB 485 / TSX C USB 232 cables

At a Glance

The TSX PCX 3030 / TSX C USB 232 / TSX C USB 485 cables are USB/RS-485 or RS232 serial link converters. They are used to connect a device with a USB port to a PLC using its terminal.

TSX PCX 3030 cable is not compatible with Windows Vista Business Edition 32, use the cable TSX C USB 485 instead.

The cables are "plug 'n' play". When you connect the cable via the USB port, Windows XP Professional Edition or Windows Vista Business Edition 32 finds a new device and tries to install the corresponding driver. It is necessary to install two drivers:

- the USB bus driver,
 - and the virtual serial port driver.
-

Installation

Important: Before connecting the cables to the USB port on the PC, you must install the UNITELWAY driver (V1.8 minimum), or the MODBUS Serial line driver (V1.5 minimum). The cable drivers are pre-installed when installing the UNITELWAY or MODBUS driver.

The following table describes the procedure to install both drivers required to use the TSX PCX 3030, TSX C USB 232, or TSX C USB 485 cable.

Step	Action
1	<p>Connect the cable to the USB port of your device.</p> <p>Result: Windows detects the new hardware and displays the assistant for installing the device driver. Click "Next": The next window is displayed:</p> 

Step	Action
2	<p>The first driver is installed. Click "Finish" to install the second driver by repeating steps 1 and 2:</p> 

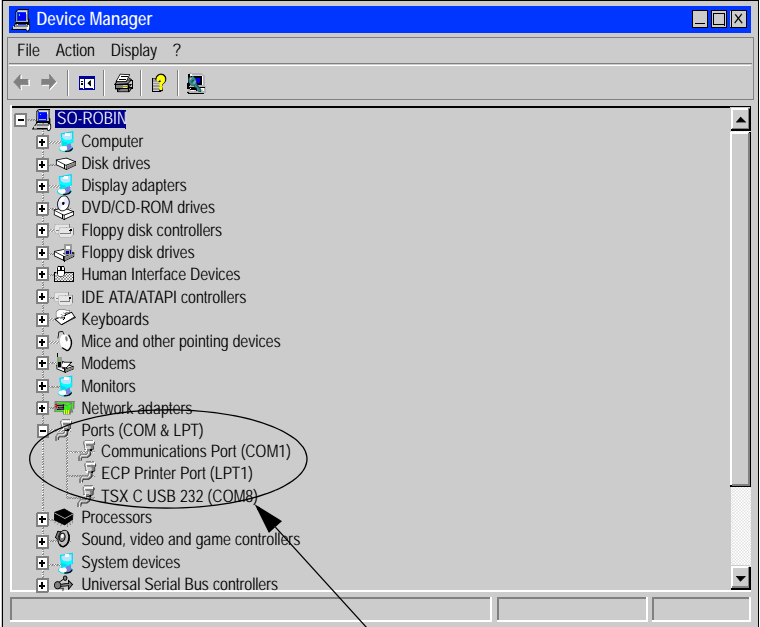
Step	Action
3	<p>To determine the COM port that the cable was mapped to, you must open the "Device Manager" window. ("Properties" on "My Computer" then the "Hardware" tab and finally the "Device Manager" button.) The following window is displayed with the reference of the cable and the name of the COM port.:</p>  <p>The screenshot shows the Windows Device Manager window for a computer named 'SO-ROBIN'. The 'Ports (COM & LPT)' category is expanded, showing three items: 'Communications Port (COM1)', 'ECP Printer Port (LPT1)', and 'TSX C USB 232 (COM8)'. The 'TSX C USB 232 (COM8)' item is circled in blue, and a black arrow points from it to the text 'Cable reference and com port' located below the screenshot.</p>

COM port number

Changing the number of the COM port assigned to the cable:

When the driver is installed, you can assign it to another communication port.

Example: The TSX C USB 232 cable is on COM8. We will reconfigure it to COM13.

From the Device Manager, select the COM8 port and open the "**properties**" window to access the port settings:

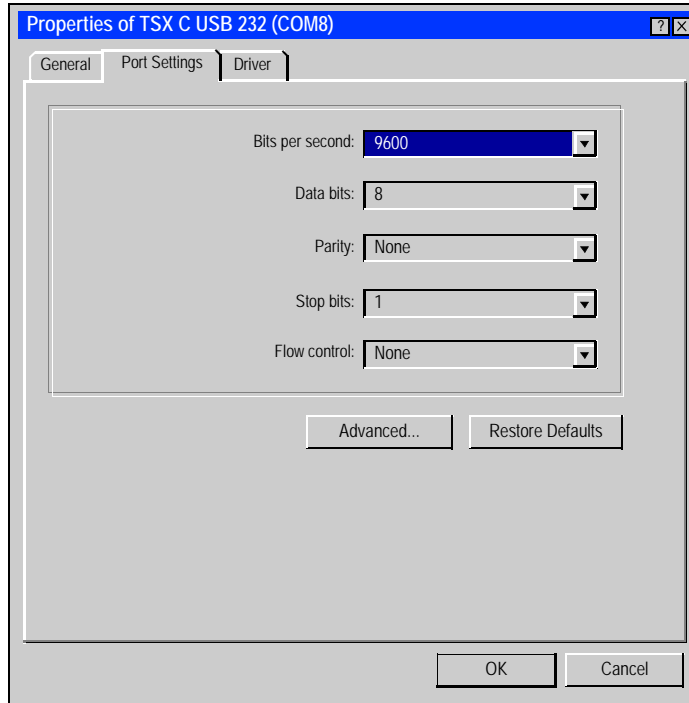

In the **"Port Settings"** tab of the COM8 properties, click **"Advanced..."**. The following window is displayed:

Advanced Settings for COM8

COM Port Number: COM13

USB Transfer Sizes

Select lower settings to correct performance problems at low baud rates:
Select higher settings for faster performance.

Receive (Bytes) 4096

Transmit (Bytes) 4096

BM Options

Select lower settings to correct response problems:

Latency Timer (msec) 16

Timeouts

Minimum Read Timeout (msec): 0

Minimum Write Timeout (msec): 0

Miscellaneous Options

Serial Enumerator

Serial Printer

Cancel If Power Off

Event On Surprise Removal

Set RST On Close

Disable Modem Ctrl At Startup

OK

Cancel

Defaults

Select port COM13, and confirm with OK, then disconnect and reconnect the TSX C USB 232 cable in order to take the new settings into account.

Configuration screens for TSX PCX 3030 / TSX C USB 232 / TSX C USB 485 cable drivers.

At a Glance

When the drivers of the TSX PCX 3030, TSX C USB 232, and TSX C USB 485 cables are installed, you must select the cables with the drivers that can use them. The compatible drivers are:

- Uni-Telway driver, version \geq V1.5,
 - Modbus driver, version \geq V1.1.
-

Uni-Telway driver

The following table describes the procedure for declaring the cable with a Uni-Telway driver:

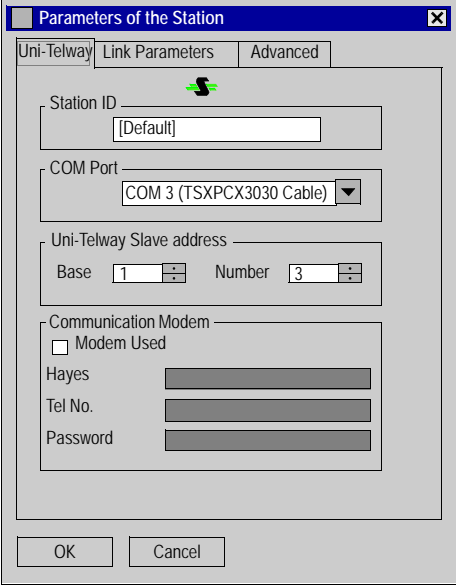
Step	Action
1	Access the Drivers Manager from the taskbar: Start → Settings → Control Panel → Driver Manager See Driver Manager Chapter (see <i>Drivers Manager</i> , p. 73)
2	From the Drivers Manager , select the Uni-Telway Driver tab.
3	Click on the Configuration button.
4	Click on the Edit button. Result: the Station parameters window appears:
	
5	Select from the Com Port zone, the communication port associated with the cable. For example COM3 (TSX PCX 3030 Cable) .

Modbus Driver

The following table describes the procedure for declaring the cable with a Modbus driver:

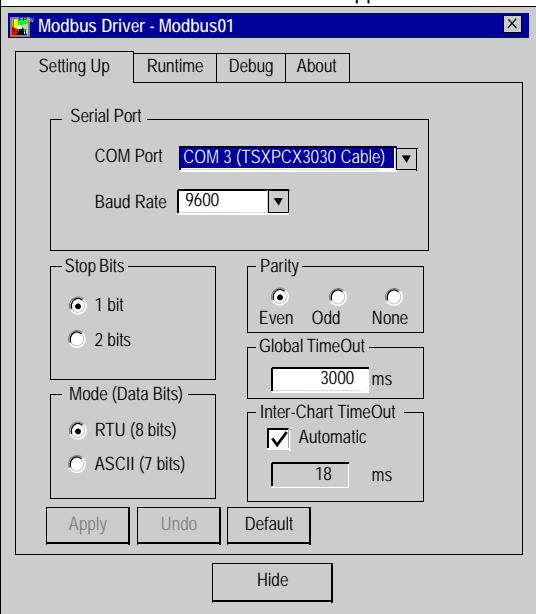
Step	Action
1	Access the Drivers Manager from the taskbar: Start → Settings → Control Panel → Driver Manager . See Driver Manager Chapter (see <i>Drivers Manager</i> , p. 73)
2	From the Drivers Manager , select the Modbus Serial Driver tab.
3	<p>Click on the Configuration button.</p> <p>Result: the Modbus Driver window appears:</p> 
4	Select from the Serial Port zone, the communication port associated with the cable. For example COM3 (TSX PCX 3030 Cable) .

XIP Driver on TCP/IP



At a Glance

Subject of this Chapter

This chapter describes driver configuration.

This driver is used to communicate via an Ethernet card using the X-Way protocol on TCP/IP.

Driver installation

For installation information, see the Driver Installation Chapter (see *Driver Installation*, p. 11)

What's in this Chapter?

This chapter contains the following topics:

Topic	Page
Driver Configuration Screen	56
How to Configure the Driver	59

Driver Configuration Screen

At a Glance

The configuration tool is used to link a driver configuration profile to a remote device that communicates with the station.

The configuration screen can be accessed by clicking: **Start** → **Settings** → **Control Panel** → **Driver Manager**. See Driver Manager Chapter (see *Drivers Manager*, p. 73)

Choose the tab corresponding to the driver to be configured and click **configure**.

Illustration

The screen dedicated to the XIP driver looks like this:

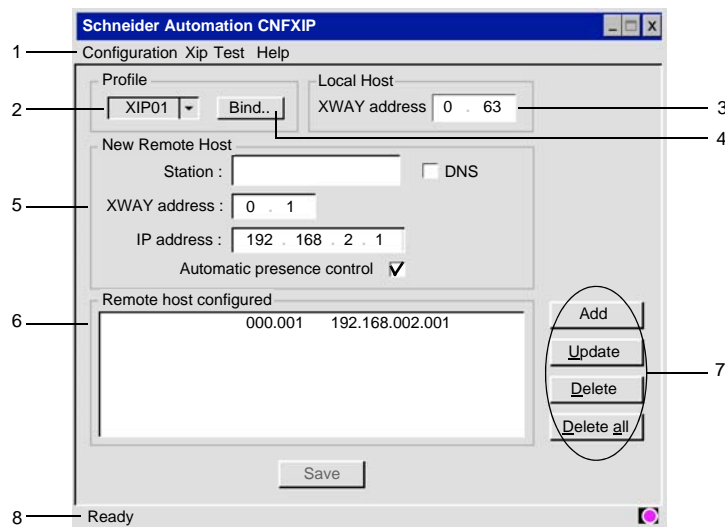

Description

This table describes the different areas which make up the configuration screen:

Number	Element
1	<p>All software functions can be accessed using this menu bar:</p> <ul style="list-style-type: none"> ● Configuration: creation or deletion of a profile ● Xip: start, stop or reinitialize the driver ● Test: test request transmissions with options <ul style="list-style-type: none"> ● UNI-TE Mirror Request (to send and receive a series of characters to/from a device supporting the UNI-TE protocol ● Ping: Standard ping to test for the presence of the station on the network. ● Help: information on the software
2	The profile used by the driver is selected from this list.
3	The X-Way address of the station is configured from this window.
4	OPens a dialog box to choose a network interface (IP address / network adapter) on which the profile will be linked. This interface will be used to communicate with PLC's.
5	<p>The new remote host with remote devices associated with the driver are set from this window.</p> <p>By checking the Automatic presence control option, you confirm a control of the workstation on the network.</p>
6	<p>Remote host configured with remote devices can be viewed via this list. Using the character "*" allows you to make a multiple selection in the next screen 002. * stands for all stations on network 2.</p> <p>Note: If you wish to communicate with a station across one or more bridges, you must not only indicate the address of the station but also that of the first bridge crossed.</p>
7	Connections can be added, removed or redefined with these buttons.
8	This status bar contains an operating indicator (driver stopped or started) with a comment zone.

When clicking the **Bind** button , the following window appears:

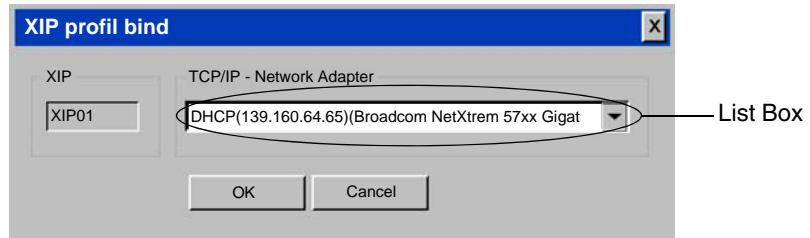

List Box: Drop down menu containing IP addresses associated to the different network adapter installed on the computer.

Menu description:

- DHCP : The IP address is associated to a DHCP Server
- (xxx.xxx.xxx.xxx): IP address.
- (xxxxxxxx xxxxxxxx xxxx xxxxx): Adapter name

How to Configure the Driver

At a Glance

During driver installation, a default configuration profile is proposed. You are able to modify this profile or create a new one.

Note: If all the network connections are in use or if there are none on the station, a profile cannot be created.

How to Create a New Profile

From the driver configuration screen (see *Driver Configuration Screen, p. 56*):

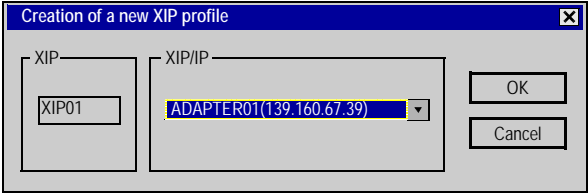
Step	Action
1	<p>Select the menu: Configuration → Create a profile. Result: The following window appears:</p> 
2	From the TCP/IP drop-down menu, select the TCP/IP connection to the network.
3	Click Ok .

How to Remove a Profile

From the driver configuration screen (see *Driver Configuration Screen, p. 56*):

Step	Action
1	Select the menu: Configuration → Create a profile .
2	From the drop-down menu, select the profile to be removed.
3	Confirm deletion with Ok .

Example

The architecture below describes the addressing of stations on Ethernet and Fipway networks:

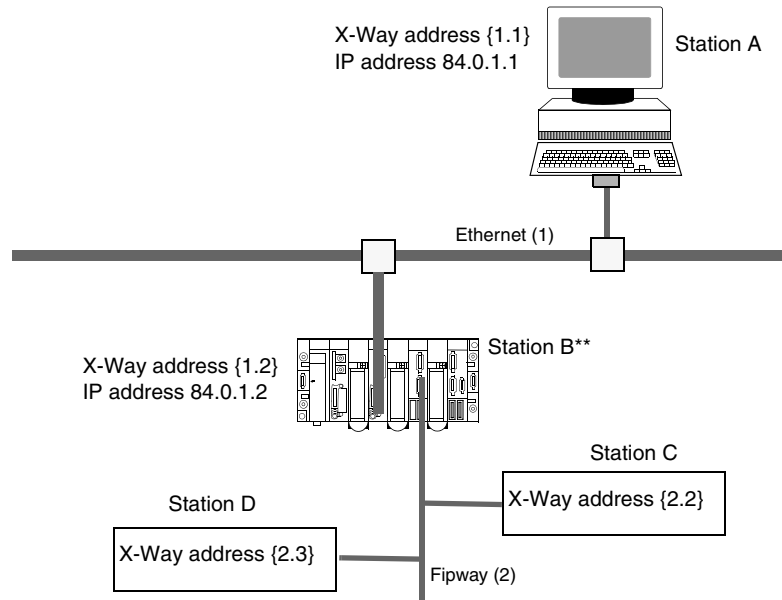

** : Station B is configured as a Router (Bridge) between the Ethernet (1) network and the Fipway (2) network. This configuration is set up using Unity Pro.

Access to Stations

To directly access all the stations on the Ethernet 1 network from station **A**, enter the X-Way address {1.*} and the IP address 84.0.1.1.

In order for station **A** to be able to access station **B**, enter for connection the X-Way address {1.2} and the IP address 84.0.1.2.

In order for station **A** to be able to access station **B**, enter the X-Way address {2.3} and the IP address of the bridge 84.0.1.2.

To directly access all the station Fipway (2) network from station **A**, enter the Xway address {2.*} and the IP address of the first you cross.

Note: When creating a bridge connection, you must configure the Xway address of the recipient PLC by assigning it the IP address of the bridge you cross.

How to Add a Connection

From the configuration screen (see *Driver Configuration Screen, p. 56*):

Step	Action
1	In the New Remote Host window, enter: <ul style="list-style-type: none"> ● the name of the remote station or bridge, ● the address of the remote station or bridge, ● the IP address of the remote station or bridge,
2	Click Add .
3	Click Save . Note: The configuration is saved for the current profile.

How to Remove a Connection

From the configuration screen (see *Driver Configuration Screen, p. 56*):

Step	Action
1	In the Remote Host Configured window, select the name of the remote station to be removed.
2	Click Delete .
3	Click Save . Note: The configuration is saved for the current profile.

How to Modify a Connection

From the configuration screen (see *Driver Configuration Screen, p. 56*):

Step	Action
1	In the Remote Host Configured window, select the name of the remote station to be modified.
2	In the New Remote Host window, modify: <ul style="list-style-type: none"> ● the name of the remote station or bridge, ● the address of the remote station or bridge, ● the IP address of the remote station or bridge,
3	Click Update .
4	Click Save . Note: The configuration is saved for the current profile.

How to change a network interface

From the configuration screen (see *Driver Configuration Screen, p. 56*):

Step	Action
1	Select the profil to be modified in the Remote Host Configured window
2	Click on Bind.. to make the the XIP profil bind window appear.
3	Select the IP/Network address to be associated with the profile.
4	Click OK
5	Restart driver in the XIP menu to apply the modifications

XIP Instances

Once installed, configure the XIP driver and reboot the computer. All XIP profile instances are initialized.

For each XIP profile configured a corresponding icon appears in the task bar.

FIP Driver for TSX C USB FIP Card



7

At a Glance

Subject of this Chapter

This chapter describes how to finalize the driver installation and to configure the driver used to communicate with the TSX C USB FIP on Fipway/Fipio network.

Driver installation

For installation information, see the Driver Installation Chapter (see *Driver Installation*, p. 11)

What's in this Chapter?

This chapter contains the following topics:

Topic	Page
Finalizing Installation	64
Driver Configuration Screen	66

Finalizing Installation

At a glance

After the driver installation (see *Driver Installation, p. 12*) phase, the operating system automatically detects the TSX C USB FIP communication adapter and its driver.

Procedure

To complete the installation:

Step	Action
1	<p>Connect the TSX C USB FIP communication adapter to the USB of the PC (or iPC).</p> <p>Result:The system detects automatically the USB device, and displays the dialog boxes to configure the driver in the Operating System.</p>
2	<p>Select No, not this time and click Next:</p>  <p>Note: In this example, the operating system is XP SP2</p>
3	<p>Select Install the software automatically (Recommended) and click Next:</p> 
4	Click Continue Anyway then Finish

Driver Configuration Screen

At a Glance

With the driver configuration tool, you can configure the driver in Fipway network or Fipio network to use the TSX C USB FIP communication adapter.

The configuration tool can be accessed from the taskbar: **Start** → **Settings** → **Control Panel** → **Driver Manager**.

Select the tab corresponding to the driver to be configured

Illustration

The card configuration screen looks like this:

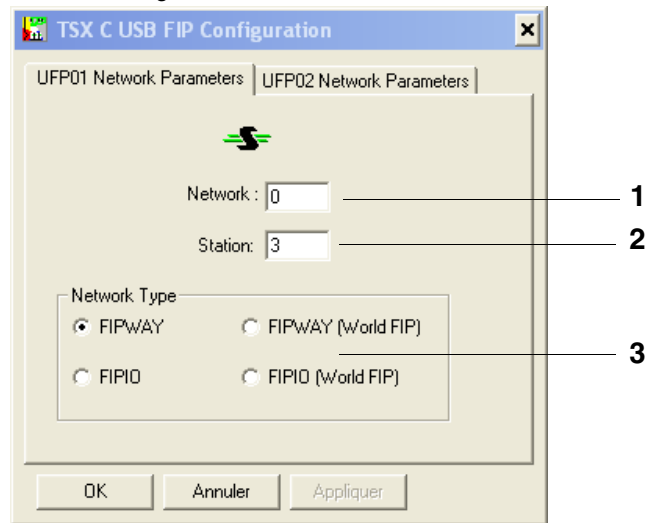

Description

This table describes the different areas which make up the configuration screen:

Number	Element
1	This field is used to set the Network address (between 0 and 127).
2	This field is used to set the Station address (between 0 and 63).
3	This window is used to select the Connexion type (FIPWAY or FIPIO).

PCIWAY driver for Atrium TSX PCI 57 xxx processors



8

At a Glance

Subject of this Chapter

This chapter describes how to configure the driver for TSX PCI 57 ••• processors on the PCI bus.

Driver installation

For installation information, see the Driver Installation Chapter (see *Driver Installation, p. 11*)

What's in this Chapter?

This chapter contains the following topics:

Topic	Page
Driver Configuration Screen	68
How to Adjust the Parameters of the TSX PCI 57 xxx Card	70

Driver Configuration Screen

Access to the configuration tool

The configuration tool can be accessed from the taskbar: **Start** → **Settings** → **Control Panel** → **Driver Manager**. See Driver Manager Chapter (see *Drivers Manager*, p. 73)

Select the **PC I 57 Driver** tab to display the following window:

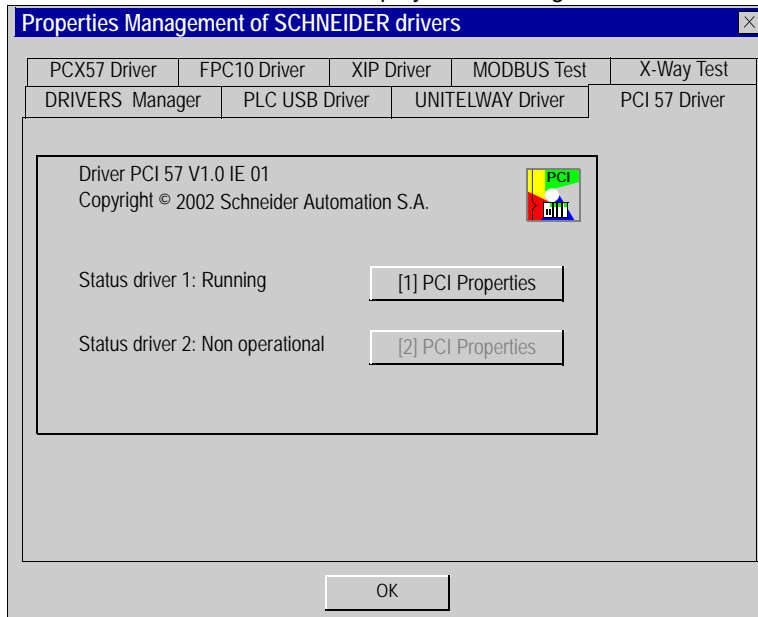

This window shows information on the version and STATUS of the driver installed.

Properties

Press the relevant **PCI Properties** button to display the following window:

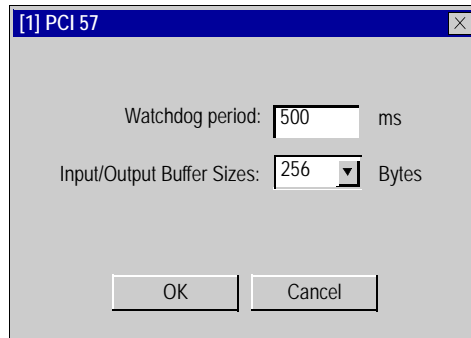

The table below describes the different areas:

Area	Description
Watchdog period	Represents the refresh period of the watchdog. The Watchdog is a function enabling a non card activity alert which will be displayed in the software.
Input/Output Buffer Sizes	Allows the size of the buffers for the interface between the TSX PCI 57 card and the driver to be configured. The size may be set at between 160 bytes and 256 bytes.
OK	Validates the configuration; the parameters displayed are stored and the previous screen is displayed.
Cancel	Cancels a modification, and returns to the previous screen.

How to Adjust the Parameters of the TSX PCI 57 xxx Card

At a Glance

Before installing the TSX PCI 57 *** card, you must:

- install the PCI 57 driver,
- code the rack number on the X Bus,
- code the position of the processor in the rack.

Note: TSX PCI 57 *** cards are all "plug and play" meaning that once you have installed the driver you can simply insert the card in its slot and it will be automatically detected when the computer is next powered up.

Note: A maximum of two TSX PCI 57 *** cards can be connected.

Illustration

This card comprises the following elements:

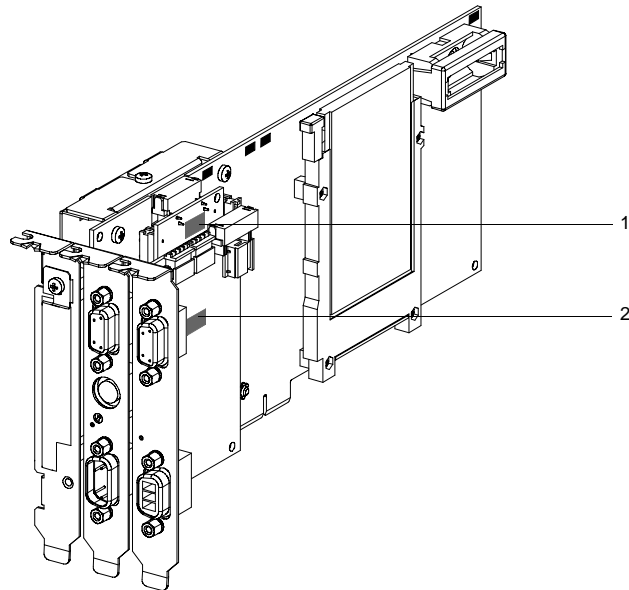

Numbers and Elements

The following table describes the different parameters to be adjusted:

Number	Element
1	The address of the rack on the X Bus can be coded with the micro-switches.
2	The processor's rack position can be coded with the micro-switches.

Procedure

To adjust the parameters, proceed in the following manner:

Step	Action
1	Code the number of the rack on the X-Bus.
2	Code the position of the processor in the rack.

Drivers Manager



At a Glance

Subject of this Chapter

This chapter describes the **Drivers Manager** management software and its functions.

Specific information on the configuration screens for individual drivers can be found in the chapters on those drivers. The remaining tabs in the **Drivers Manager** are described here.

What's in this Chapter?

This chapter contains the following topics:

Topic	Page
Management of X-Way drivers	74
X-Way addressing modes	79

Management of X-Way drivers

At a Glance

The X-Way drivers can be accessed using the **Drivers Manager** management tool. This is used to install, update, configure and test the different drivers in a centralized manner.

Accessing the Drivers Management Tool

From the Start menu, go to: **Start** → **Setting** → **Control Panel** → **Driver Manager**. Select the **Drivers Manager** tab, and the following window is displayed:

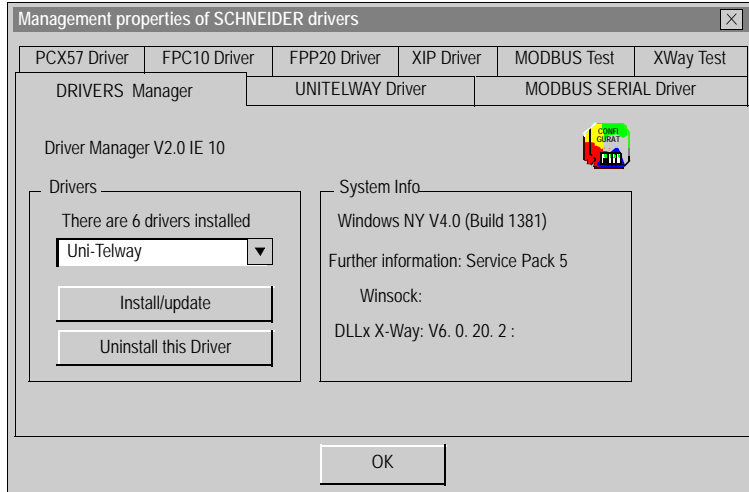

Drivers Manager tab

This tab (window above) is used to:

- view the list of installed drivers,
 - install or update a driver,
 - delete a driver.
-

X-Way Test Tab

This tab is used to test the basic operation of an X-Way driver:

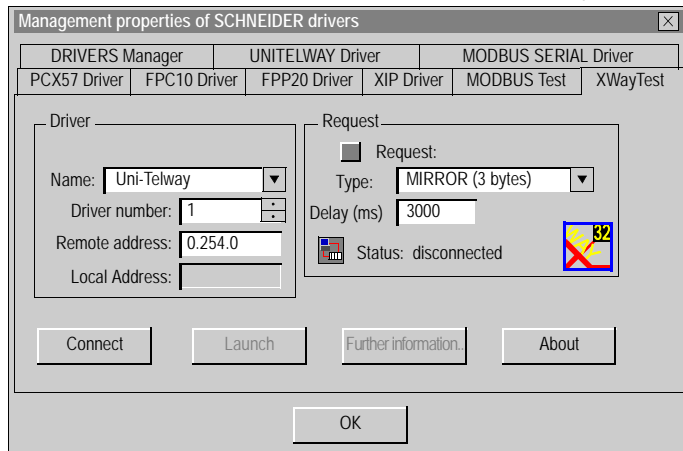

The table below describes the different zones of the window:

Driver Group	
Field	Description
Name	Name of driver to be used for the test (Uni-Telway, FPC 10, etc).
Driver number	Instance number of driver to be used for the test (usually 1).
Remote Address	X-Way remote station address in the format "network.station.gate". The address "0.254.0" is the default address (terminal port for example). For a network connection, (such as Fipway), the user must complete this field: "3.5.0" to address station 5 of network 3. Gate 0 corresponds to the system server gate of the station in question. See X-Way addressing modes (see <i>X-Way addressing modes</i> , p. 79) page for more information. (see <i>X-Way addressing modes</i> , p. 79)
Local Address	Internal address used locally by the driver. The driver completes this field automatically for information purposes when the connection becomes effective.

Request Group	
Field	Description
Request	Name of driver to be used for the test (Uni-Telway, FPC 10).
Type	Type of request. Different sizes of mirror requests are suggested, as well as reading the PLC system bit %S6.
Delay	Wait timeout in ms for the response to the transmitted request (time out).
Status	Status of connection, "disconnected", "connecting..." or "connected".

Command buttons	
Object	Description
Connect	Opens an internal communication channel on the selected driver.
Launch	Launch request transmission to the station defined in the Remote address field of the Driver group.
Further information...	Displays system information about the driver. This button is active in online mode only.
About	Displays X-Way Manager version and copyright details.

Modbus Test Tab This tab is used to test the basic operation of a Modbus driver:

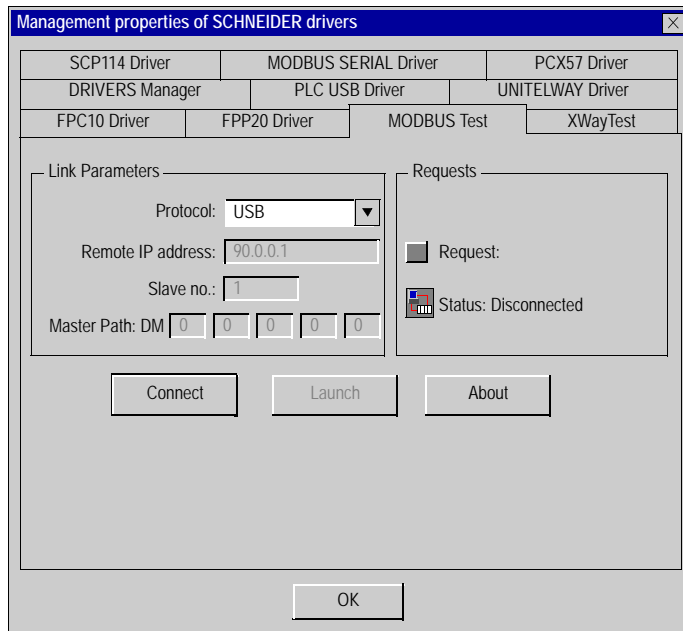

The table below describes the different zones of the window:

Link Parameters Group	
Field	Description
Protocol	Name of protocol used (USB, TCP, Serial Modbus, Modbus Plus).
Remote IP address	If TCP is being used, then the IP address or machine name is shown here
Slave No.	If Serial Modbus protocol is being used, then the slave no. is shown here.
Master Path: DM	If Modbus Plus protocol is being used, then the station address is shown here.

Request Group	
Field	Description
Request	
Status	Status of connection, "disconnected", "connecting..." or "connected".

Command buttons	
Object	Description
Connect	Opens an internal communication channel on the selected driver.
Launch	Launch request transmission to the station defined in the Remote IP address field of the Link Parameters group.
About	Displays X-Way Manager version and copyright details.

Other Tabs

The windows corresponding to these tabs are described in the corresponding chapters for each driver:

- for the Modbus Serial driver tab see, Configuration of the Modbus driver (see *Configuration of the Modbus Driver* , p. 18)
 - for the Uni-Telway driver tab:
 - if using a serial port see *Driver Configuration Screens*, p. 32,
 - if using a TSX SCP 114 card see *Driver Configuration Screens*, p. 128,
 - for the USB driver tab see *State of the USB link*, p. 42.
 - for the XIP driver see *Driver Configuration Screen*, p. 56,
 - for the TSX C USB FIP driver tab see ,Configuration of USB FIP driver (see *Driver Configuration Screen*, p. 66)
 - for the FPP 20 driver tab see *Driver configuration screen*, p. 96,
 - for the FPC 10 driver tab see *Description*, p. 109,
 - for the PCI 57 driver tab see *Driver Configuration Screen*, p. 68,
 - for the PCX 57 driver tab see *Configuration of ISAWAY driver*, p. 121
-

X-Way addressing modes

Description

Example of access through a network:

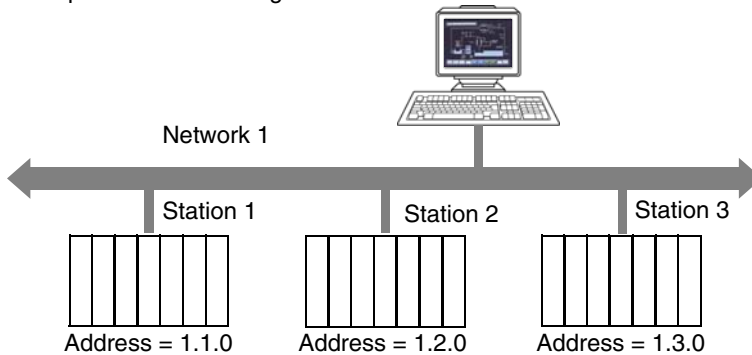

Addressing to 3 levels:

Allows a station connected to the network at any point of the X-Way communication architecture to be reached.

Illustration:



The Network and Station values make up the station address.

- Network: value between [1.127] or 0 = my network.
- Station: value between [1.63] or 254 = my station or 255 = diffusion.

The value "Gate" refers to the communication entity within the station: system server (Gate 0, the most common), the terminal port (Gates 1,2,3), 1K asynchronous server (Gate 7), etc.

In the case of multiprocessor stations such as PLCs, each processor module built into the system can support communication entities, frame routing requiring supplementary addressing levels (inter-station routing capabilities). PLC "processor modules" are situated in the PLC's racks or offset on field buses.

Addressing to 5 levels:

It is generally used for devices connected on a Uni-Telway bus.

Illustration:

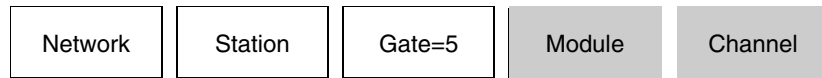

- **Module:** physical location of the communication module in the rack. Its value must be defined as follows: $(\text{Master rack number} * 16) + \text{Number of master module}$.
- **Channel:** address of the device connected to the communication module. Its value must be defined as follows: $(\text{Master channel number} * 100) + \text{slave Ad0 number}$.

Addressing to 6 levels:

This is similar to addressing to 5 levels. It was created for extended services (FIPIO, communication module integrated in rack).

Illustration:

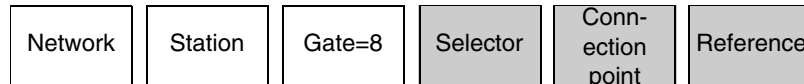

- **Selector:** designates a communication module on the CPU (2) or in a separate module (1).
- **Connection point:** device address, if the destination module is FIPIO. Physical positioning in the PLC rack, if the destination module is a PLC card.
- **Reference:** communication entity in the device (similar to the Gate number).

Examples:

5 level addressing:

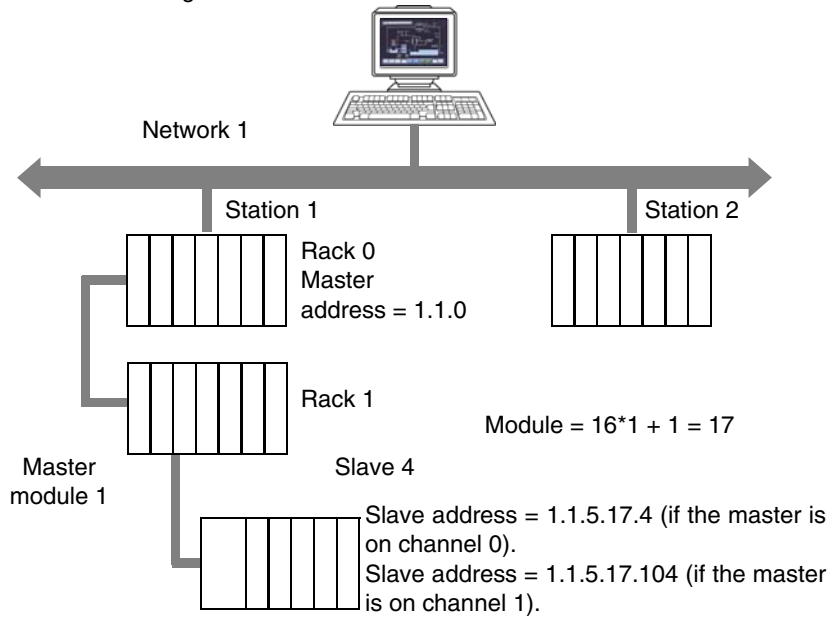

6 level addressing:

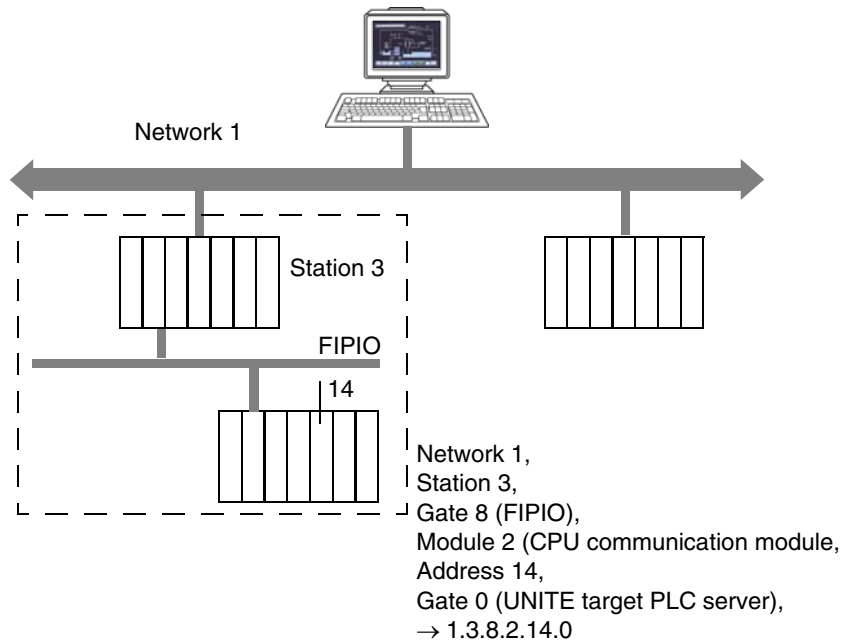

For more information on the X-Way address, see "X-Way Communication" documentation, ref. TSX DR NET.

Note:

In point to point connections (Uni-Telway, ISAWay, PCIway), the default address 0.254.0 can be used to reference the PLC.

0.254.0 can be used to access to the Fipio Master when we are connected through the privileged terminal @63

0.254.5.17.104 can be used to access to the Uni-Telway slave @4 which is connected on the rack 1 module 1 channel 1 when we are connected on the local PLC.

0.254.8.2.14.0 can be used to access to the Fipio connection point 14 when we are connected through the privileged terminal @63.

With Ethway and XIP, it is possible to use gate 7, which accepts large frames (up to 1024 bytes). In order to do this, the PL7 application must be configured in periodic mode (MAST task). The "1K service" option must be checked in the alias definition page.

Example: normal address: XIP01:1.2, to use gate 7: XIP01:1.2.7

Troubleshooting

10

At a Glance

Subject of this Chapter

This chapter contains 2 troubleshooting tables:

- Installation troubleshooting.
- Configuration troubleshooting.

What's in this Chapter?

This chapter contains the following topics:

Topic	Page
Installation Troubleshooting	84
Configuration Troubleshooting	86

Installation Troubleshooting

Introduction

This troubleshooting table will help you find solutions to difficulties you might encounter during the installation of your device driver.

Difficulties and Solutions

Identify your difficulty in the left column then follow the corresponding solution instructions on the right:

Difficulty	Solution
When the CD-ROM is inserted the driver web page does not open	Explore the CD-ROM content and double-click "_installdrivers.htm" to launch the web page.
During the installation, a driver setup dialog box appears "You are not administrator, you cannot install drivers"	You must be administrator in order to install drivers. Make sure you have administrator rights.
The driver does not install	<ul style="list-style-type: none"> ● The drivers available on the CD are only compatible with Windows XP Professional Edition and Windows Vista Business Edition 32. Make sure your computer is currently running one of those operating systems.see Operating System Compatibility Table (see <i>Document Scope, p. 9</i>) <p>If this solution does not solve the problem, then:</p> <ul style="list-style-type: none"> ● Check / change Driver Signing options in System <ol style="list-style-type: none"> 1.From the Start menu go to: Start → Settings → Control panel 2.Double-click System 3.Choose the "Hardware" tab 4.Click Driver Signing button 5.Choose Warn - display 6.Click OK 7.Click OK to close the System window. <p>Validation above does not work under Windows Vista Business Edition 32 (all drivers are already signed)</p>

Difficulty	Solution
<p>When the USB device is connected, the Found New Hardware Wizard appears.</p>	<p>The driver may not be installed or not updated:</p> <ol style="list-style-type: none"> 1. Click Cancel from the Found New Hardware Wizard 2. Remove the device as follows: <ol style="list-style-type: none"> a. From the Start menu go to: Start → Settings → Control Panel b. Double click System c. Choose the Hardware tab d. Click on the Device Manager button. e. Find the device with the yellow question mark. f. Right-click on that device and choose Uninstall. g. Click OK in the Confirm Device Removal dialog box. h. Disconnect the device. 3. Now install the requested driver with the supplied CD-ROM, following the Driver Installation Procedure (see <i>Driver Installation, p. 12</i>) 4. Reconnect the device.
<p>While installing a driver, a dialog box appears indicating to Repair/Update or Remove the driver.</p>	<p>Choose Repair/Update and go to step 6 of the "Installation Procedure" in the Driver Installation (see <i>Driver Installation, p. 12</i>) chapter.</p>

Configuration Troubleshooting

Introduction

This troubleshooting table will help you find solutions to difficulties you might encounter during the configuration of your device driver.

Difficulties and solution

Identify your difficulty in the left column then follow the corresponding solution instructions on the right.

Difficulty	Solution
The driver tab cannot be seen in the driver manager	The driver tabs correspond to the drivers currently installed on your computer. Install the required driver by following the driver installation procedure (see <i>Driver Installation</i> , p. 12).
The driver manager remains on the computer after uninstalling all the drivers	<ol style="list-style-type: none"> 1. From the Start menu go to: Start → Settings → Front Panel → Add or Remove Programs 2. Click on the Delete button corresponding to the driver manager.
The configuration window does not appear at the end of a driver installation	<p>Double click on the driver manager shortcut on your desktop.If you have no shortcut, then:</p> <ol style="list-style-type: none"> 1. From the Start menu go to: Start → Settings → Front Panel. 2. Double-click Driver Manager. 3. Click on the tab corresponding to the driver to be configured.

Appendices



At a glance

Overview

This section describes how to finalize the installation and configure drivers for hardware that is no longer manufactured by Schneider Electric.

What's in this Appendix?

The appendix contains the following chapters:

Chapter	Chapter Name	Page
A	Ethway Driver	89
B	FIP Driver for TSX FPP 20 Card	95
C	FIP Driver for TSX FPC 10 ISA Card	99
D	ISAWAY driver for Atrium TPCX 57 processors	111
E	Uni-Telway driver for TSX SCP 114 Card	127

Ethway Driver



At a Glance

Subject of this Chapter

This chapter describes how install and configure the Ethway driver.

This driver is used to communicate via an Ethernet card using the ETHWAY protocol.

What's in this Chapter?

This chapter contains the following topics:

Topic	Page
How to Install the Driver	90
Driver Configuration Tool	92

How to Install the Driver

At a Glance

The ETHWAY protocol is installed from the driver CD-ROM, but does not follow the standard driver installation procedure.

How to Install the Driver

The ETHWAY driver is installed in accordance with the following procedure:

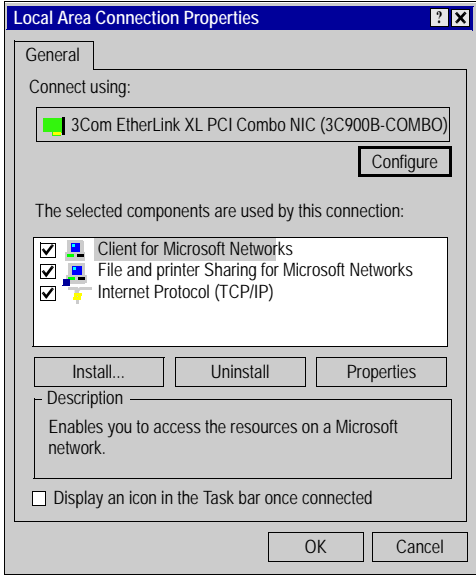
Step	Action
1	Insert the CD-ROM.
2	Access the Control Panel in Windows.
3	Double-click on the Network connections and Remote access icon.
4	<p>Select the icon Local connection then by right-clicking select the command Propriete</p> <p>Result: The following window appears:</p> 
5	Click on the Install button.

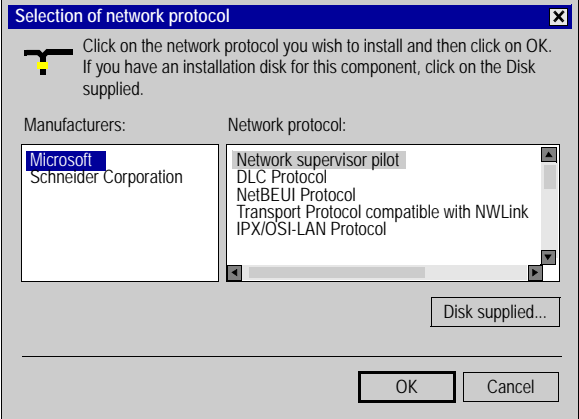
Step	Action
6	<p>In the Select Network Component Type window, select the type Protocol then click on Add.</p> <p>Result: The following window appears:</p> 
7	Click on Have Disk .
8	Select the access path of the files to be installed from the CD-ROM using the Browse button.
9	Click on Ok .
10	In this window select the ETHWAY Protocol then click on OK .
11	Select the ETHWAY protocol then click on Properties .
12	In the configuration screen (see <i>Driver Configuration Tool</i> , p. 92), configure the protocol then click on OK .
13	Complete the installation by clicking on OK .

Driver Configuration Tool

At a Glance

The configuration tool is used to configure the Ethernet card to communicate according to the ETHWAY protocol.

How to Access the Configuration Tool

The ETHWAY driver configuration tool is accessed as follows:

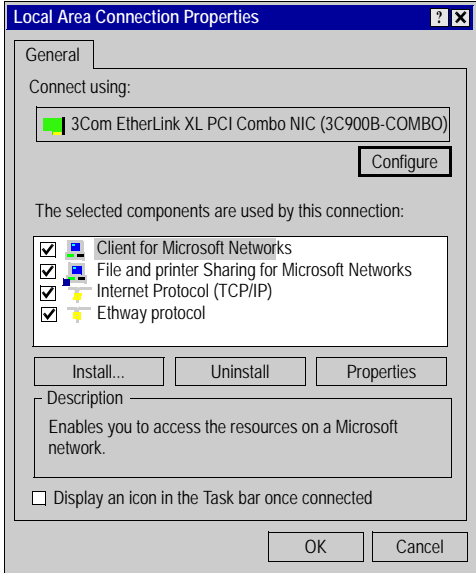
Step	Action
1	Access the Control Panel in Windows.
2	Double-click on the Network connections and Remote access icon.
3	<p>Select the icon Local connection then by right-clicking select the command Properties.</p> <p>Result: The following window appears:</p> 
4	<p>Select the ETHWAY protocol then click on Properties.</p> <p>Result: The Ethway Configuration Screen appears</p>

Illustration

The card configuration screen looks like this:

The screenshot shows the 'ETHWAY Protocol Properties' dialog box. It contains several sections and fields:

- Adapter Name:** A text field containing 'el3c5891'. A line labeled '1' points to this field.
- Export Name:** A text field containing 'ETHWAY01'. A line labeled '2' points to this field.
- Network and Station:** Two spinners. The 'Network' spinner is set to '0' and the 'Station' spinner is set to '63'. A line labeled '3' points to both of these spinners.
- TE MAC Address:** A checkbox that is currently unchecked. A line labeled '4' points to this checkbox.
- Acknowledgement (ms):** A section containing two spinners: 'Retry Period' set to '800' and 'Filter Period' set to '3000'. A line labeled '5' points to this section.
- Buffers:** A section containing two spinners: 'Send' set to '50' and 'Receive' set to '20'. A line labeled '6' points to the 'Send' spinner. To the right of these spinners are radio buttons for 'Size' with options '128', '256', '512', and '1024'. The '1024' option is selected.
- Buttons:** At the bottom right is a 'Default' button. At the very bottom are 'OK' and 'Cancel' buttons.

Description

This table describes the different areas which make up the configuration screen:

Number	Element
1	This field is used to select the Ethernet card (useful if there are several Ethernet cards). This field cannot be modified under Windows XP Professional Edition or Windows Vista Business Edition 32.
2	This field is used to select the ETHWAY driver instance. This field cannot be modified under Windows XP Professional Edition or Windows Vista Business Edition 32.
3	These windows are used to define the address {Network.Station} of the Ethernet card used.
4	This box is used to replace the Ethernet card's MAC address with the SCHNEIDER MAC address (00 80 F4 Network Station).
5	This window is used to configure the reception acknowledgment by defining: <ul style="list-style-type: none">● the retransmission period between two frames if the remote device is not responding,● the storage time of a frame originating from the remote device (useful for loaded networks). Note: In general, storage time is three times the retransmission period.
6	This window is used to configure the transmission and reception buffer size in bytes.

FIP Driver for TSX FPP 20 Card



B

At a Glance

Subject of this Chapter

This chapter describes configuration of the driver used to communicate with the TSX FPP20 on Fipway\Fipio network.

Driver installation

For installation information, see the Driver Installation Chapter (see *Driver Installation, p. 11*)

What's in this Chapter?

This chapter contains the following topics:

Topic	Page
Driver configuration screen	96
Finalizing installation	97

Driver configuration screen

At a Glance

The configuration tool is used to configure the driver to use the TSX FPP 20 card on Fipway or Fipio network.

The configuration tool can be accessed from the taskbar: **Start** → **Settings** → **Control Panel** → **Driver Manager**.

Select the tab corresponding to the driver to be configured, then click the **Configuration** button.

Illustration

The screen dedicated to the card driver looks like this:

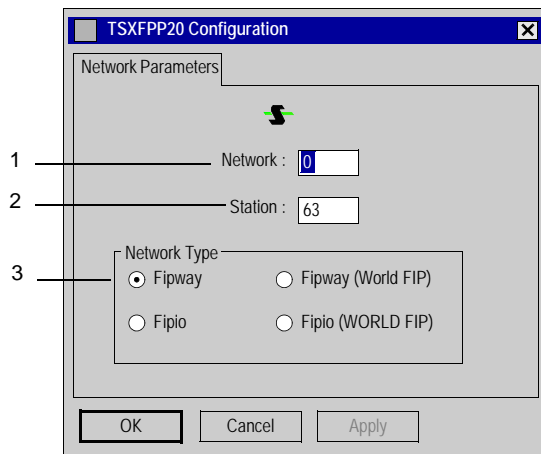

Description

This table describes the different areas which make up the configuration screen:

Number	Element
1	This field is used to set the network address (between 0 and 127).
2	This field is used to set the station address (between 0 and 63)
3	This window is used to select the type of Fipway or Fipio connection.

This table describes the configuration tool is used to configure the driver to use the TSX FPP OZD 200:

Number	Element
1	This field is used to set the network address (between 0 to 127).
2	This field is used to set the station address (between 0 to 32).

Finalizing installation

At a Glance

After the driver installation and configuration phase, the operating system shall recognize the TSX FPP 20 card and its driver.

Note: When configuring the system, it is not necessary to restart the station.

How to Configure the Operating System

The following procedure describes how to configure the operating system:

Step	Action
1	Install and configure the driver.
2	Insert the PCMCIA card into its slot. Result: The system automatically detects the card and loads the card driver.

FIP Driver for TSX FPC 10 ISA Card



C

At a Glance

Subject of this Chapter

This chapter describes how to finalize the installation and to configure the driver used to communicate with the TSX FPC 10 ISA card on Fipway\Fipio network.

This chapter contains the following information:

- Finalizing the installation.
- Configuration of the driver.

Driver installation

For installation information, see the Driver Installation Chapter (see *Driver Installation, p. 11*)

What's in this Chapter?

This chapter contains the following topics:

Topic	Page
Finalizing the installation of the TSX FPC 10 Card	100
How to Select the Hardware Type	101
How to Configure Hardware Parameters	104
How to Adjust the TSX FPC 10 ISA Card Parameters	107
Driver configuration screen	109

Finalizing the installation of the TSX FPC 10 Card

At a Glance

After the driver installation and configuration phase, the operating system does not automatically recognize the ISA TSX FPC 10 card and its driver.

Installation Principles

As this card is not automatically recognized by the operating system, the following phases must be carried out:

Step	Action
1	Select the hardware type: <i>See How to Select the Hardware Type, p. 101.</i>
2	Configure the parameters of the operating system to recognize the card: <i>See How to Configure Hardware Parameters, p. 104,</i>
3	Switch off the PC.
4	Adjust the card parameters (<i>See How to Adjust the TSX FPC 10 ISA Card Parameters, p. 107</i>): <ul style="list-style-type: none">● the standard I/O address,● the IRQ interrupt address.
5	Connect the card to the ISA bus.
6	Turn the PC back on. Result: the driver is operational.

How to Select the Hardware Type

Procedure

After having installed and configured the driver, carry out the following procedure to select the hardware type:

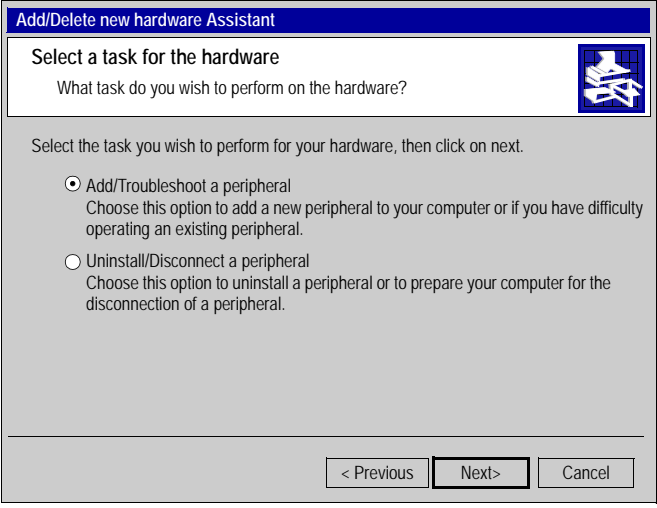
Step	Action
1	<p>From the Driver Manager window, choose the FPC 10 Driver tab, then click Hardware Wizard, click on Next.</p> <p>Result: The following window appears:</p> 

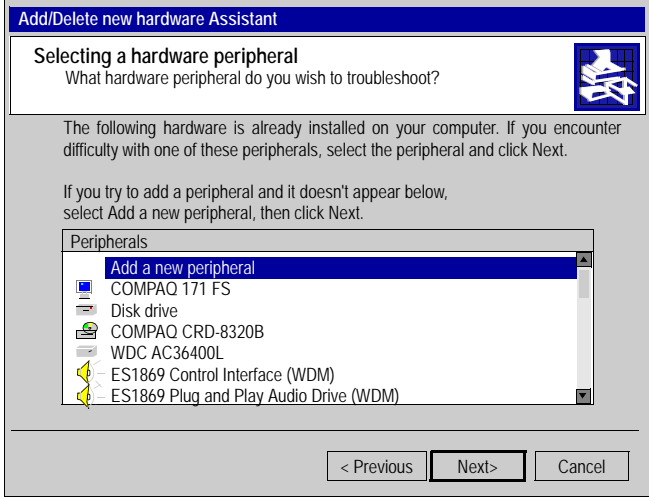
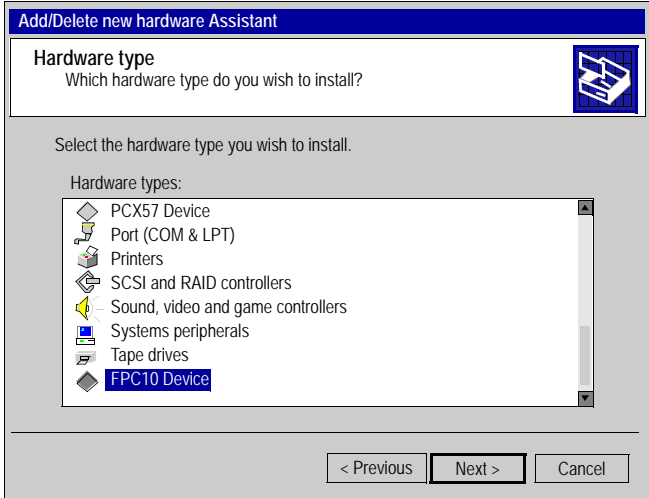
Step	Action
2	<p>Select the option Add/Troubleshoot a peripheral then click Next. Result: The following window appears:</p> 
3	<p>Select the option Add a new peripheral then click Next.</p>
4	<p>Answer No to the question Do you want Windows to search for your new hardware?</p>
5	<p>Click on Next. Result: The following window appears:</p> 

Step	Action
6	Select FPC 10 Device from the list then click on Next .
7	Select FPC 10 WDM Device from the list then click on Next . Result: an information window appears.
8	A window informs the user that the hardware parameters of the card must be entered by the user. Click on OK and go to the next procedure: how to configure hardware parameters (see <i>How to Configure Hardware Parameters, p. 104</i>).

How to Configure Hardware Parameters

Procedure

After having selected the hardware type, carry out the following procedure to configure the parameters:

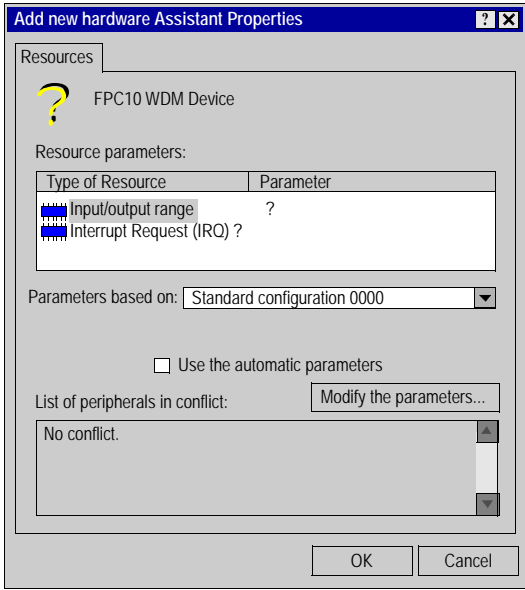
Step	Action
1	Click on the Resources button.
2	<p>Click on Manual Configuration. Result: The following window appears:</p> 
3	Select Input/Output Range from the list.
4	Verify the box Use automatic settings is not checked.

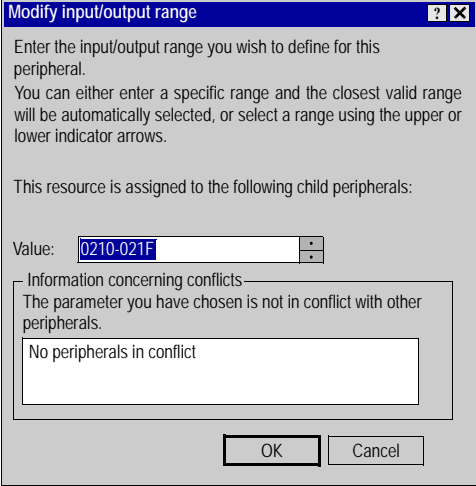
Step	Action
5	<p>Click on Change settings.</p> <p>Result: The following window appears:</p> 
6	<p>From the Value list, select the non-conflicting address range.</p> <p>Note: Note the values because they must be coded onto the ISA card.</p>
7	<p>Confirm with OK.</p> <p>Result: a confirmation window appears.</p>
8	<p>Confirm with Yes.</p>
9	<p>Carry out steps 3 to 8 selecting Interrupt Request from the list.</p>

Step	Action
10	<p>Accept the configuration with OK. Result: The following window appears:</p> 
11	Click on Finish to confirm hardware configuration.

How to Adjust the TSX FPC 10 ISA Card Parameters

At a Glance

Before installing the TSX FPC 10 card, you must adjust the following parameters:

- the standard I/O address,
- the IRQ interrupt address.

Illustration

This card comprises the following elements:

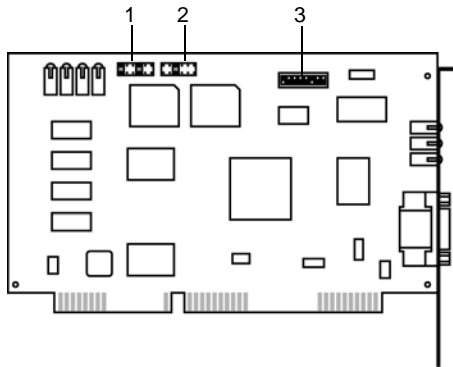

Numbers and Elements

The following table describes the different parameters to be adjusted:

Number	Element
1	Jumpers (SW1) are used to select the DMA channel (Direct Memory Access) (no object).
2	A jumper (SW2) is used to select the IRQ (Interrupt Request) level.
3	The micro-switches (SW3) are used to select the standard address of the card in the I/O space.

Procedure

To adjust the parameters, proceed in the following manner:

Step	Action
1	Set the IRQ interrupt jumper to comply with the address provided by the or Vista/XP (see <i>How to Configure Hardware Parameters, p. 104</i>) operating systems.
2	Code the standard I/O address provided by the operating system or Vista/XP (see <i>How to Configure Hardware Parameters, p. 104</i>) with the micro-switches.

Example of IRQ Selection

The interrupt address provided by the system is 10:

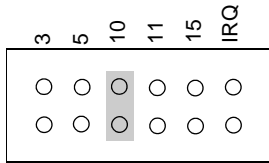

Note: The jumper must not be set in the IRQ position.

Example of Standard Address Selection

The standard address provided by the system is equal to 210 in hexadecimal:



Driver configuration screen

At a Glance

The configuration tool is used to configure the driver in Fipway or Fipio mode to use a ISA TSX FPC 10 card on Fipway/Fipio network.

The configuration tool can be accessed from the taskbar: **Start** → **Settings** → **Control Panel** → **Driver Manager**.

Select the tab corresponding to the driver to be configured, then click **[FIP01]/[FIP02] Properties**.

Illustration

The screen dedicated to the card driver looks like this:

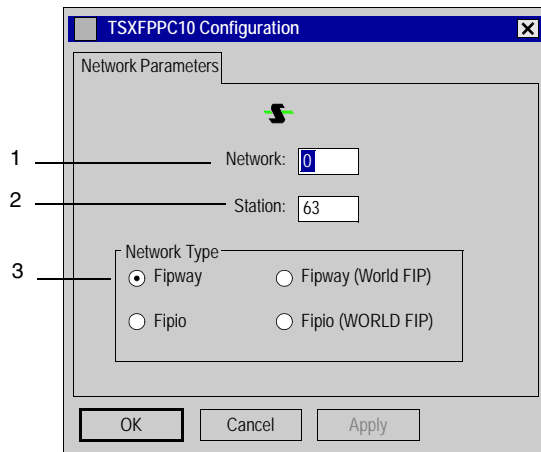

Description

This table describes the different areas which make up the configuration screen:

Number	Element
1	This field is used to set the network address.
2	This field is used to set the station address.
3	This window is used to select the type of Fipway or Fipio connection.

ISAWAY driver for Atrium TPCX 57 processors



D

At a Glance

Subject of this Chapter

This chapter describes how to finalize the installation and to configure the driver for the TPCX 57 processor.

This chapter contains the following information:

- Finalizing the installation
- Configuration of the driver

Driver installation

For installation information, see the Driver Installation Chapter (see *Driver Installation*, p. 11)

What's in this Chapter?

This chapter contains the following topics:

Topic	Page
Finalizing the installation	112
How to select the hardware type	113
How to configure hardware parameters	116
How to adjust the ISA TPCX 57 card parameters	119
Configuration of ISAWAY driver	121

Finalizing the installation

At a Glance

After following the Driver Installation (see *Driver Installation*, p. 12) and configuration phase, the operating system does not automatically recognize the TPCX 57 card and its driver.

Installation principles

As this card is not automatically recognized by the operating system, the following phases must be carried out:

Step	Action
1	Select the hardware type: <i>See How to select the hardware type, p. 113.</i>
2	Configure the parameters of the operating system to recognize the card: <i>See How to configure hardware parameters, p. 116,</i>
3	Switch off the PC.
4	Adjust the card parameters: <i>See How to adjust the ISA TPCX 57 card parameters, p. 119.</i> <ul style="list-style-type: none">● the standard I/O address,● the IRQ interrupt address.
5	Connect the card to the ISA bus.
6	Turn the PC back on. Result: the driver and the TPCX 57 card are operational.

How to select the hardware type

Procedure

After having installed and configured the driver, carry out the following procedure to select the hardware type:

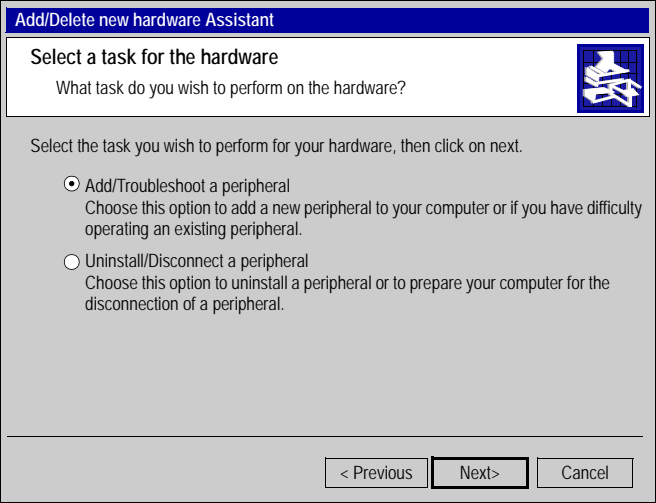
Step	Action
1	<p>From the Driver Manager window, choose the PCX 57 tab, then click Hardware Wizard followed by Next.</p> <p>Result: The following window appears:</p> 

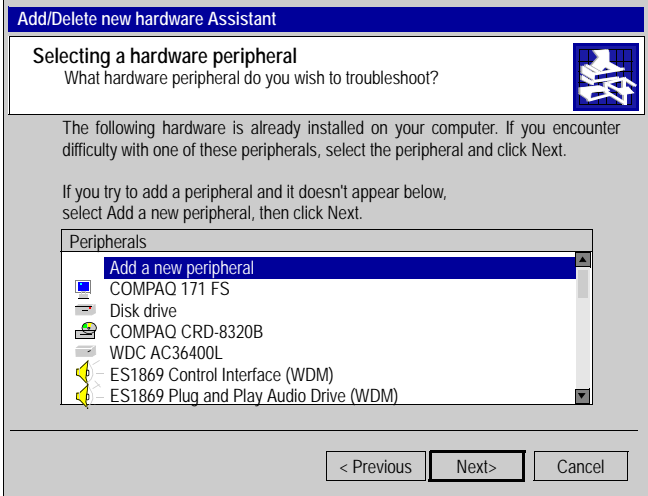
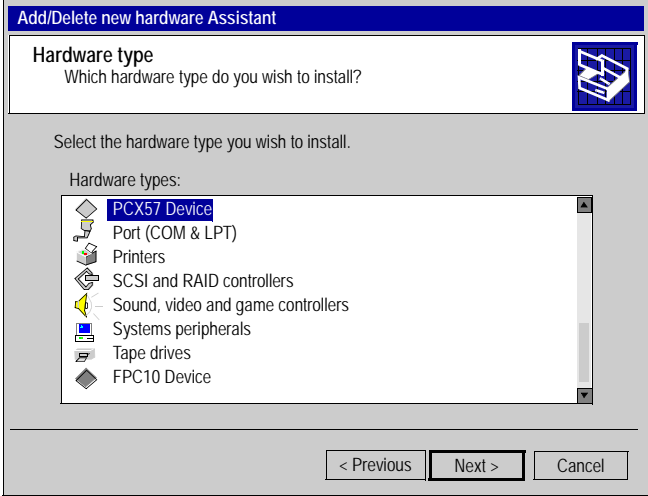
Step	Action
2	<p>Select the option Add/Troubleshoot a peripheral then click Next. Result: The following window appears:</p> 
3	<p>Select the option Add a new peripheral. Then click on Next.</p>
4	<p>Answer No to the question Do you want Windows to search for your new hardware?</p>
5	<p>Click on Next. Result: The following window appears:</p> 

Step	Action
6	Select PCX 57 Device from the list then click on Next .
7	Select PCX 57 WDM Device from the list then click on Next .
8	Go to the next procedure: how to configure hardware parameters (see <i>How to configure hardware parameters, p. 116</i>).

How to configure hardware parameters

Procedure

After having selected the hardware type, carry out the following procedure to configure the parameters:

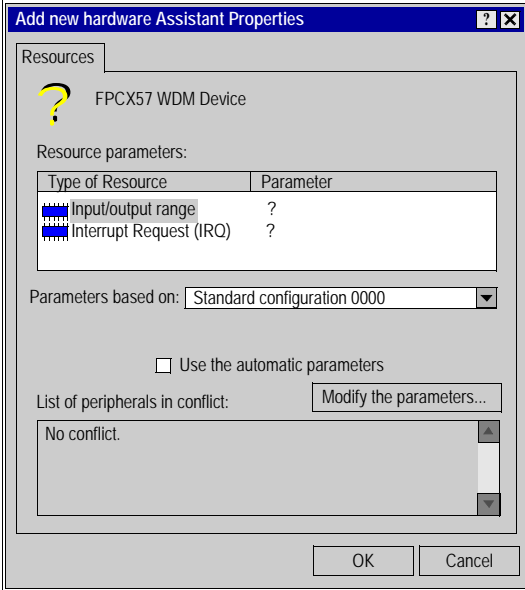
Step	Action
1	Click on the Resources button.
2	<p>Click on Manual Configuration. Result: The following window appears:</p> 

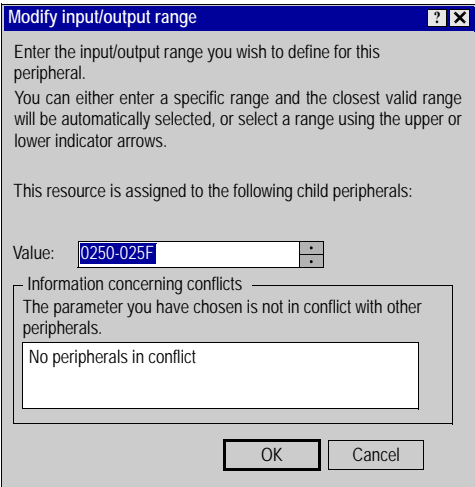
Step	Action
3	<p>Select Input/Output Range from the list.</p> 
4	Verify that the box Use automatic settings is not checked.
5	Click on Modify the parameters... Result: The following window appears:
6	From the Value list, select the non-conflicting address range. Note: Note the values because they must be coded onto the ISA card.
7	Confirm with OK . Result: a confirmation window appears.
8	Confirm with Yes .
9	Carry out steps 3 to 8 selecting Interrupt Request from the list.

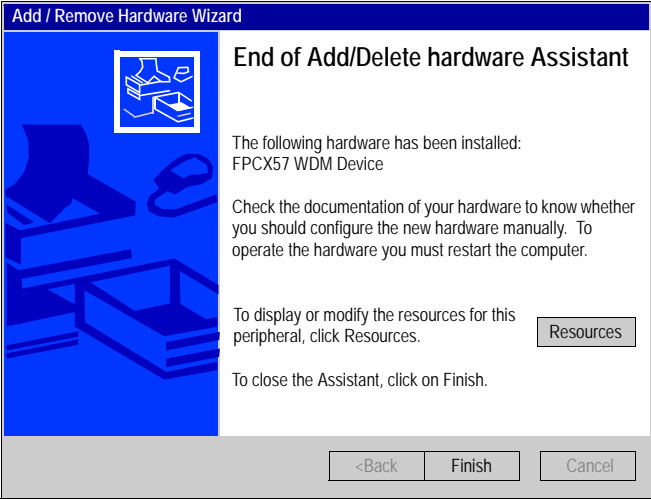
Step	Action
10	<p>Accept the configuration with OK.</p> <p>Result: The following window appears:</p> 
11	Click on Finish to confirm hardware configuration.

How to adjust the ISA TPCX 57 card parameters

At a Glance

Before installing the TPCX 57 card, you must adjust the following parameters:

- the rack number and the processor position,
- the standard I/O address,
- the IRQ interrupt address.

Illustration

This card comprises the following elements:

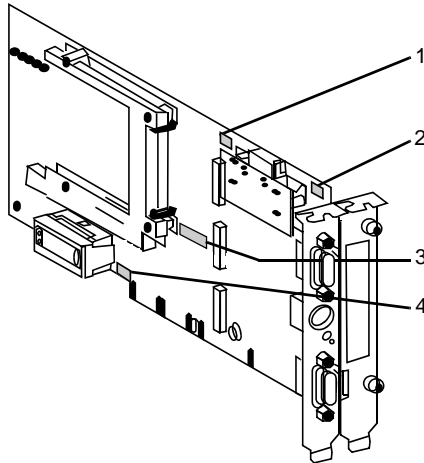

Numbers and elements

The following table describes the different parameters to be adjusted:

Number	Element
1	The processor's rack position can be coded with the micro-switches.
2	The address of the rack which contains the processor can be coded with the micro-switches.
3	The standard address of the processor can be coded on the ISA bus with the micro-switches.
4	The IRQ (Interrupt Request) level can be coded with the micro-switches.

Procedure

To adjust the parameters, proceed in the following manner:

Step	Action
1	Code the number of the rack which contains the processor.
2	Code the processor position.
3	Code the standard I/O address provided by the operating system with the micro-switches.
4	Code the interrupt level provided by the operating system with the micro-switches.

Example of standard address selection

The standard address provided by the system is equal to 250 in hexadecimal:

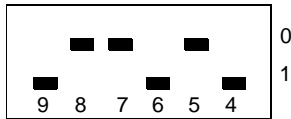

Example of IRQ selection

The interrupt address provided by the system is 10:

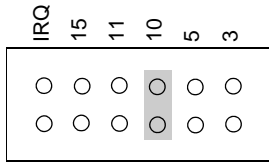

Note: The jumper must not be set in the IRQ position.

Configuration of ISAWAY driver

At a Glance

The configuration tool is used to configure the ISAWAY driver for the TPCX 57 card.

The configuration tool can be accessed from the taskbar: **Start** → **Settings** → **Control Panel** → **Driver Manager**. See Driver Manager Chapter (see *Drivers Manager*, p. 73)

Select the **PCX 57 Driver** tab to display the following window:

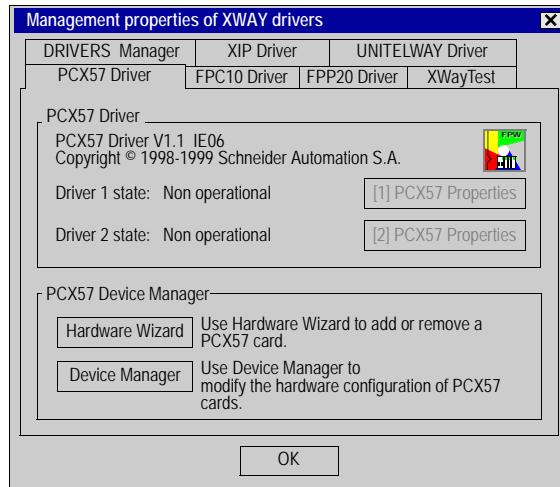

Elements

The **Properties** button is used to access the driver configuration screen for card 1 and card 2 respectively.

The **Hardware Wizard** button is used to add or remove an ISA TPCX 57 card using the Add/Remove Hardware Wizard.

Note: A maximum of two cards can be connected.

The **Device Manager** button activates the **System Properties** window and is used to view or modify the card hardware parameters.

Properties configuration

From the **PCX 57** tab in the **Driver Manager**, press the **PCX 57 Properties** button corresponding to your card in order to display the following window:

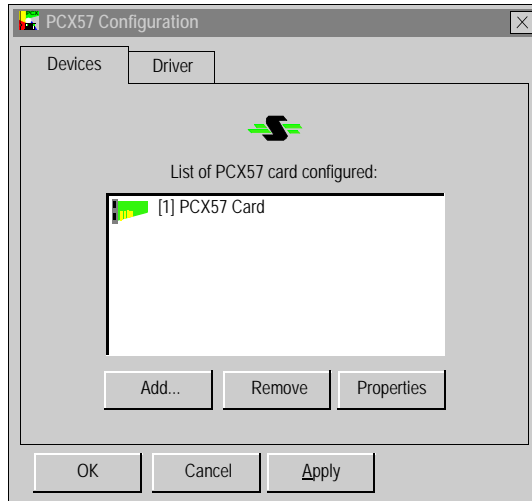

The table below describes the different commands in the tab "**Devices**":

Button	Action
Add...	Allows a TPCX 57 processor card with default parameters (IRQ =10, base address I/O=H'220', timer=500ms, buffer size=256 bytes) to be added to the PC. The maximum number of cards is 2.
Remove	Deletes the selected TPCX 57 processor card.
Properties	Allows the properties of a processor card to be defined, see: <i>Properties, p. 124</i> .
Apply	Allows configuration parameters to be applied; the tool saves the parameters, then reinitializes the driver.
Cancel	Allows the user to exit without acknowledging the modified parameters.
OK	Allows the user to exit while acknowledging the modified parameters.

Click the **"Driver"** tab in the **Properties Configuration** window to display the following window:

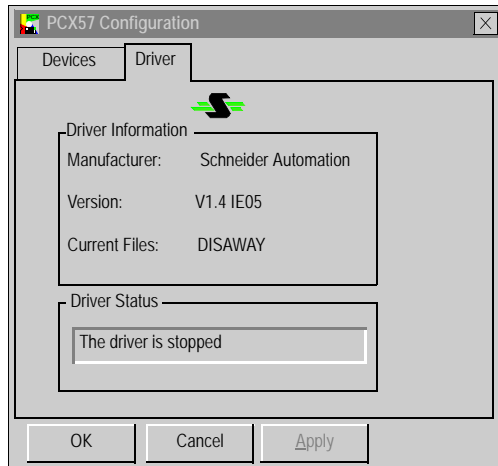

This window displays general information on the driver.

Properties

Press the **Properties** button in the *Properties configuration*, p. 122 to display the following window:

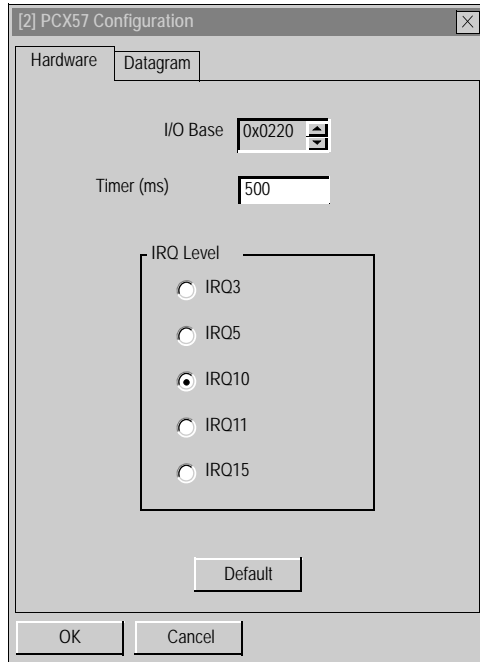

The table below describes the different areas:

Area	Description
I/O Base	This is the address of the PCX 57 card in hexadecimal, which should correspond to the address configured on the processor card.
Timer(ms)	Represents the watchdog refreshment period, which is updated by the driver.
IRQ Level	Use to set the IRQ level
Default	Displays the default configuration of the card (IRQ=10, I/O Base=H'220', Timer=500ms).
Cancel	Cancels a modification, and returns to the previous screen.
OK	Validates the configuration; the parameters displayed are stored and the previous screen is displayed.

Click the **Datagram** tab to display the following window:

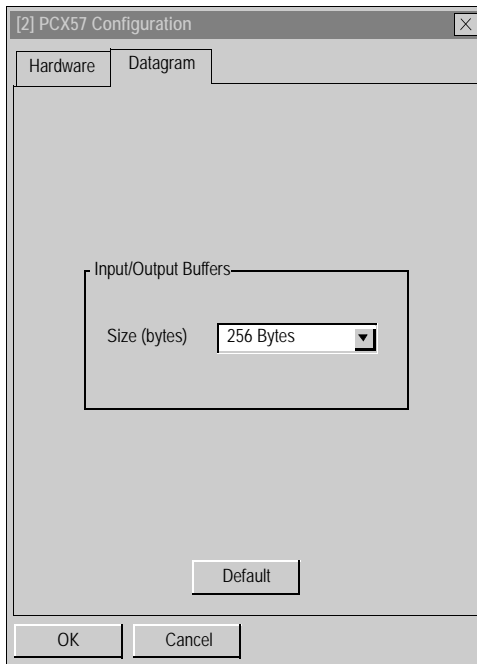

The table below describes the different areas:

Area	Description
Input/Output buffer	Allows the size of the buffers for the interface between the PCX 57 card and the driver to be configured. The size may be set at between 160 bytes and 256 bytes.
Default	Allows default selection of the card (256 bytes)
Cancel	Cancels a modification, and returns to the previous screen.
OK	Validates the configuration; the parameters displayed are stored and the previous screen is displayed.

Uni-Telway driver for TSX SCP 114 Card



At a Glance

Subject of this Chapter

This chapter describes configuration of the Uni-Telway driver communicating in slave mode via the TSX SCP 114 PCMCIA card with a remote device.

Driver Installation

For installation information, see the Driver Installation Chapter (see *Driver Installation*, p. 11)

What's in this Chapter?

This chapter contains the following topics:

Topic	Page
Driver Configuration Screens	128
Finalizing installation	130

Driver Configuration Screens

At a Glance

The configuration tool is used to configure the TSX SCP 114 card Uni-Telway driver. The configuration tool can be accessed from the taskbar: **Start** → **Settings** → **Control Panel** → **Driver Manager**.

Select the tab corresponding to the driver to be configured in the Driver Manager window.

Illustration

The screen dedicated to the Uni-Telway driver looks like this:

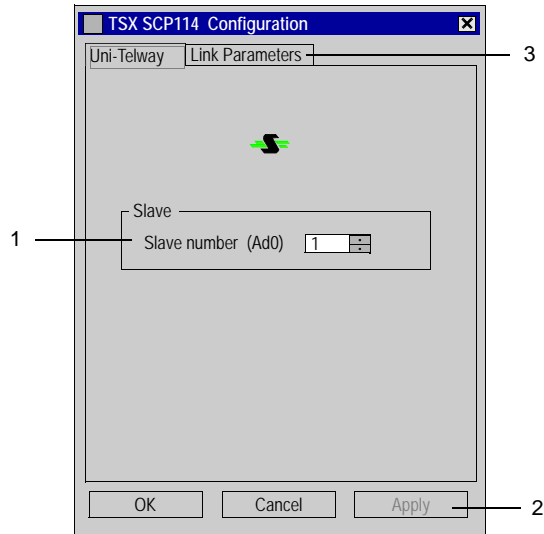

Description

This table describes the different areas which make up the configuration screen:

Number	Element
1	This window is used to set the standard slave address (Ad0) used by the card.
2	This button is used to recognize the address.
3	This tab is used to access the configuration of transmission parameters.

Link Parameters To access the Link Parameters, select the **Link Parameters** tab:

The screenshot shows a dialog box titled "Station Parameters" with a sub-tab "Link Parameters". The dialog contains the following controls:

- Speed:** A dropdown menu set to "9600 bits/s".
- Delay:** A checkbox labeled "Default" is checked, followed by a spin box set to "10" and the unit "ms".
- Data Content:** Radio buttons for "7 bits" and "8 bits", with "8 bits" selected.
- Parity:** Radio buttons for "Even", "Odd", and "Without", with "Even" selected.
- Stop Bits:** Radio buttons for "1 bit" and "2 bits", with "1 bit" selected.
- RTS/CTS Delay:** A spin box set to "1" followed by "X 100 ms".
- Buttons:** "Cancel" and "Default" buttons are located below the main settings area. At the bottom of the dialog are "OK", "Cancel", and "Apply" buttons.

Description

This tab is used to configure the parameters linked to transmission:

Element	Description
Speed	transmission speed of between 300 bits per second and 19,200 bits per second
Delay	sets the delay.
Data Content	specifies the size of the data exchanged over the line.
Parity	is used to set whether a parity bit is added or not, as well as its type.
Stop Bits	is used to enter the number of stop bits used for communication.
RTS/CTS Delay	enables the CTS signal to be used in the event of multidrop communication.
Default Button	button is used to reset all these parameters to their default value.

Finalizing installation

At a Glance

After the driver installation and configuration phase, the operating system shall recognize the TSX SCP 114 card and its driver.

Note: When configuring the system, it is not necessary to restart the PC.

How to Configure the Operating System

The following procedure describes how to configure the operating system:

Step	Action
1	Install and configure the driver.
2	Insert the PCMCIA card into its slot. Result: The system automatically detects the card and loads the card driver.

Index

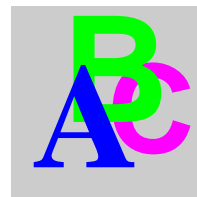

A

addressing

TPCX57, 119

TSXPCI57, 70

X-Way, 79

Atrium TPCX 57 processors, 111

Atrium TSX PCI 57 xxx processors, 67

E

Ethway Driver, 89

I

ISAWAY

drivers, 111

M

modem

modbus driver, 26

P

PCIWAY

drivers, 67

T

TSX C USB FIP Card, 63

TSX FPC 10 ISA Card, 99

TSX FPP 20 Card, 95

TSX SCP 114 Card, 127

TSXCUSB232, 45

TSXCUSB485, 45

TSXPCX3030, 45

U

USB

drivers, 40

USB cables

drivers, 45

X

XIP Driver, 55

