

Comunicação Modbus/TCP – M580 e Micro820

Giselle Morais / Adailson Apolinário

Comunicação Modbus/TCP – M580 e Micro820

Objetivo

Passo a passo da configuração de comunicação Modbus TCP do M580 com o Micro820 via:

- Comunicação implícita no M580 (IO Scanning)
- Comunicação explícita no M580 (READ_VAR e WRITE_VAR)

A seguir temos:

- Arquitetura utilizada na realização dos testes
- Fluxo de configuração da comunicação.

Comunicação Modbus/TCP – M580 e Micro820

Bancada de Testes



Comunicação Modbus/TCP – M580 e Micro820

Arquitetura utilizada na realização dos testes

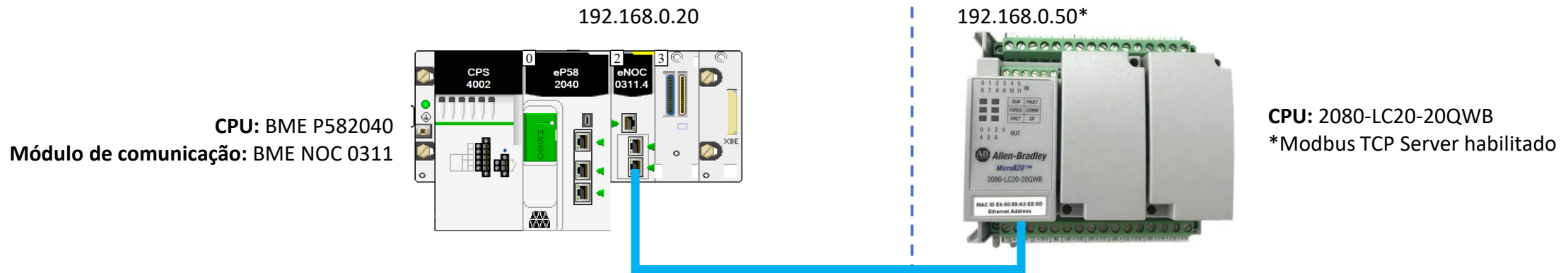

Comunicação Modbus/TCP – M580 e Micro820

Fluxo de configuração da comunicação

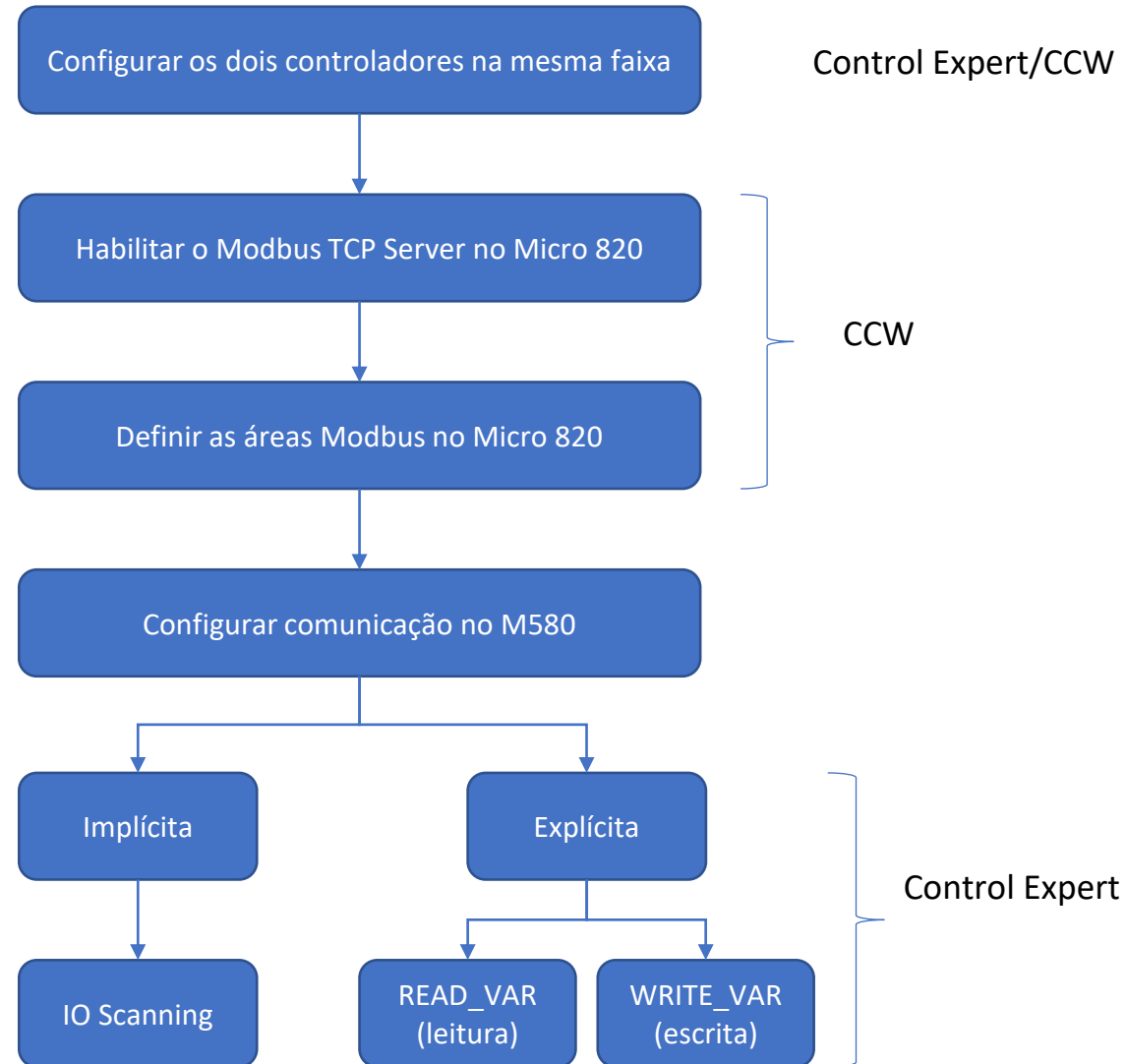

Configuração de Rede dos devices

Configurar os dois controladores na mesma faixa

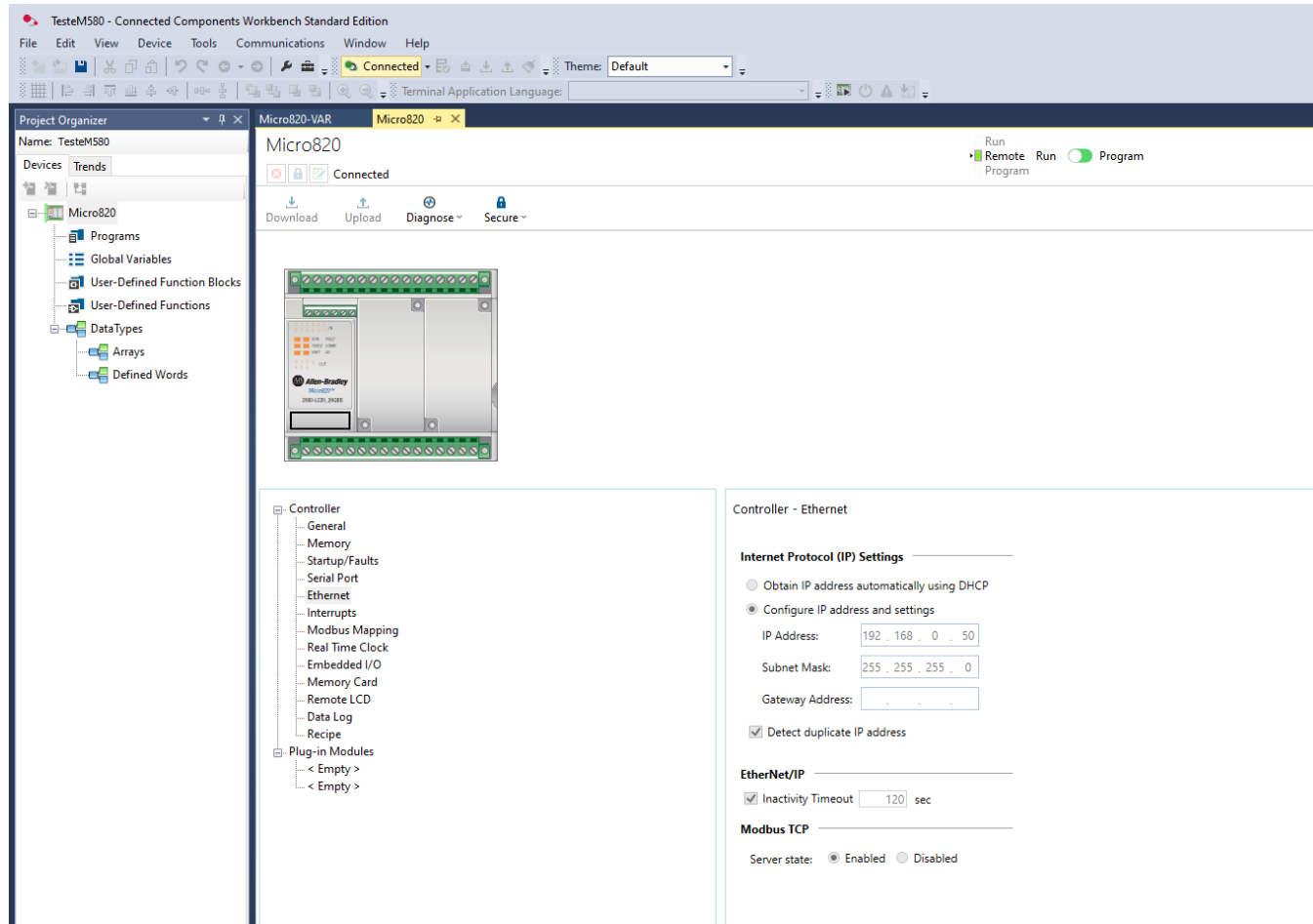

Micro820

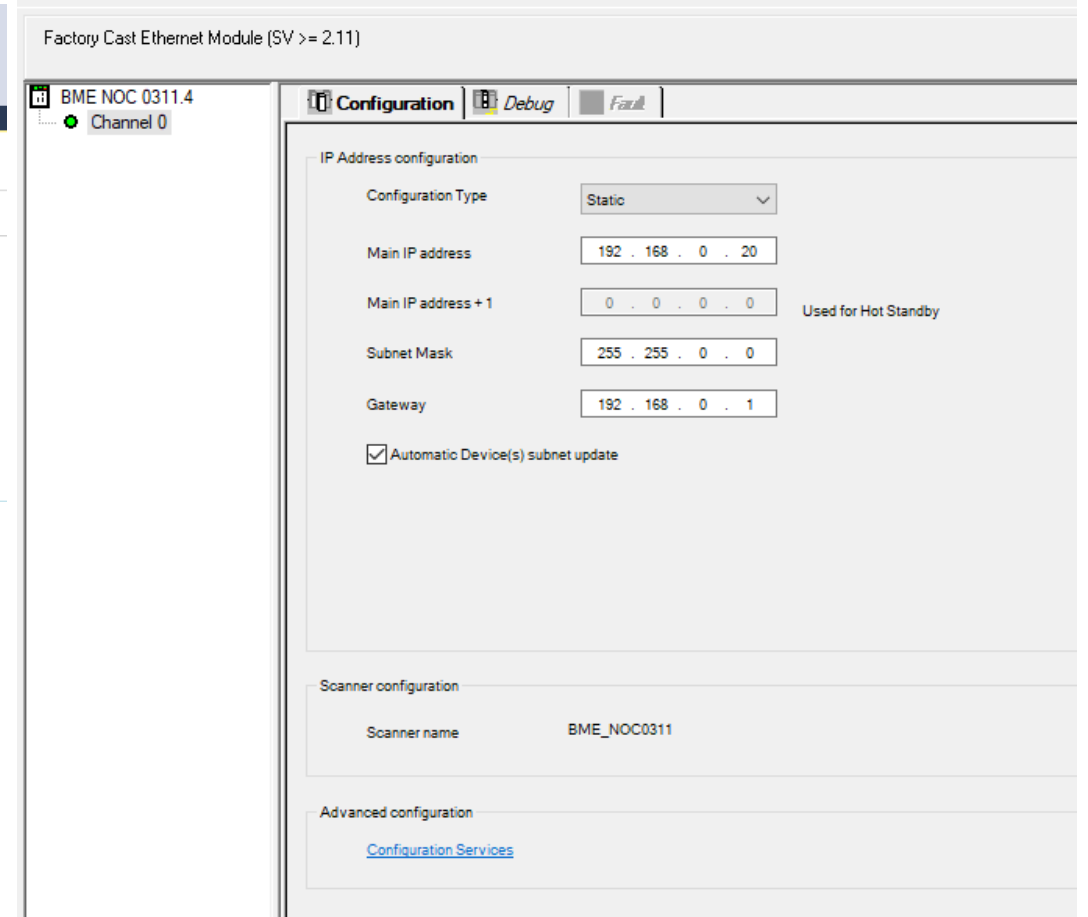

M580 Utilizamos o NOC como switch

Configuração do Micro820

Habilitar o Modbus TCP Server no Micro 820

Controller - Ethernet

Internet Protocol (IP) Settings

Obtain IP address automatically using DHCP

Configure IP address and settings

IP Address:

Subnet Mask:

Gateway Address:

Detect duplicate IP address

EtherNet/IP

Inactivity Timeout sec

Modbus TCP

Server state: Enabled Disabled

Configuração do Micro820

Definir as áreas Modbus no Micro 820

Configuramos as áreas de memória para troca de dados no Modbus Mapping:

- Controller
 - General
 - Memory
 - Startup/Faults
 - Serial Port
 - Ethernet
 - Interrupts
 - Modbus Mapping
 - Real Time Clock
 - Embedded I/O
 - Memory Card
 - Remote LCD
 - Data Log
 - Recipe
- Plug-in Modules
 - < Empty >
 - < Empty >

Controller - Modbus Mapping

⚠ To communicate via Ethernet, ensure Modbus TCP 'Server State' is 'Enabled' on [Ethernet Configuration Page](#).

Add Duplicate Import Export

Variable Name	Data Type	Address	Addresses Used
leitura	WORD[1..10]	400001	400001 - 400010 X
escrita	WORD[1..10]	400011	400011 - 400020
leitura_RV	WORD[1..10]	400101	400101 - 400110
escrita_WV	WORD[1..10]	400111	400111 - 400120

Comunicação via IO Scanning (Implícita)

Configuração do M580

Configuração via IO Scanning no NOC

The screenshot displays the NOC software interface for configuring IO Scanning. The left sidebar shows a tree view with the following structure:

- BMENOC0311_4 Communication
 - Channel Properties
 - Switch
 - TCP/IP
 - Services
 - Address Server
 - SNMP
 - RSTP
 - QoS
 - Service Port
 - Security
 - EtherNet/IP Local Slaves
 - Device List
 - [000] Micro820 <MDB: 192.168.0.50>
 - Request 001: Items
 - Logging

The main configuration area has three tabs: Properties, Address Setting, and Request Setting. The Request Setting tab is active, showing a table with the following data:

Repetitive Rate(ms)	RD Address	RD Length	Last Value	WR Address	WR Length	xy/Bridge
60	0	10	Set to Zero	10	10	<input type="checkbox"/>
						<input type="checkbox"/>
						<input type="checkbox"/>
						<input type="checkbox"/>
						<input type="checkbox"/>
						<input type="checkbox"/>
						<input type="checkbox"/>
						<input type="checkbox"/>
						<input type="checkbox"/>
						<input type="checkbox"/>

The right sidebar shows the 'Input' and 'Output' configuration panels. The 'Input' panel has a table with the following data:

Offset/Device	Offset/Connection	Item Name
0	0	[0] MICRO_IN
16	1	1
16	2	2 [1]
16	3	3
16	4	4 [2]
16	5	5
16	6	6 [3]
16	7	7
16	8	8 [4]
16	9	9
16	10	10 [5]

The 'Output' panel has a table with the following data:

Offset/Device	Offset/Connection	Item Name
0	0	[0] Micro_out
16	1	1
16	2	2 [1]
16	3	3
16	4	4 [2]
16	5	5
16	6	6 [3]
16	7	7
16	8	8 [4]
16	9	9
16	10	10 [5]

Buttons for 'Define Item(s)', 'Delete Item(s)', and 'Show Properties' are present in both panels. A 'Default Item Name Root' field is set to 'BLOCKA'. A note at the bottom of the panels reads: 'Select a region and click on the "Define Item(s)" button to create - one or several item(s) - an array'.

The diagram at the top right shows the 'IO Scanning' module with a green arrow labeled 'Leitura' pointing to the address range 400001 .. 400010 and a red arrow labeled 'Escrita' pointing to the address range 400011 .. 400019.

Configuração do M580

E a estrutura de dados é gerada conforme imagem abaixo

Name	Type	Value	Comment	Alias	Alias of	Address	HMI variable	R/W Rights of Reference
Micro820	T_Micro820						<input type="checkbox"/>	<input type="checkbox"/>
Freshness	BOOL		Global Freshne...				<input type="checkbox"/>	<input type="checkbox"/>
Freshness_1	BOOL		Freshness of O...				<input type="checkbox"/>	<input type="checkbox"/>
Inputs	T_Micro820_IN		Input Variables				<input type="checkbox"/>	<input type="checkbox"/>
MICRO_IN	ARRAY[0..9] OF WORD						<input type="checkbox"/>	<input type="checkbox"/>
MICRO_IN[0]	WORD						<input type="checkbox"/>	<input type="checkbox"/>
MICRO_IN[1]	WORD						<input type="checkbox"/>	<input type="checkbox"/>
MICRO_IN[2]	WORD						<input type="checkbox"/>	<input type="checkbox"/>
MICRO_IN[3]	WORD						<input type="checkbox"/>	<input type="checkbox"/>
MICRO_IN[4]	WORD						<input type="checkbox"/>	<input type="checkbox"/>
MICRO_IN[5]	WORD						<input type="checkbox"/>	<input type="checkbox"/>
MICRO_IN[6]	WORD						<input type="checkbox"/>	<input type="checkbox"/>
MICRO_IN[7]	WORD						<input type="checkbox"/>	<input type="checkbox"/>
MICRO_IN[8]	WORD						<input type="checkbox"/>	<input type="checkbox"/>
MICRO_IN[9]	WORD						<input type="checkbox"/>	<input type="checkbox"/>
Outputs	T_Micro820_OUT		Output Variables				<input type="checkbox"/>	<input type="checkbox"/>
Micro_out	ARRAY[0..9] OF WORD						<input type="checkbox"/>	<input type="checkbox"/>
Micro_out[0]	WORD						<input type="checkbox"/>	<input type="checkbox"/>
Micro_out[1]	WORD						<input type="checkbox"/>	<input type="checkbox"/>
Micro_out[2]	WORD						<input type="checkbox"/>	<input type="checkbox"/>
Micro_out[3]	WORD						<input type="checkbox"/>	<input type="checkbox"/>
Micro_out[4]	WORD						<input type="checkbox"/>	<input type="checkbox"/>
Micro_out[5]	WORD						<input type="checkbox"/>	<input type="checkbox"/>
Micro_out[6]	WORD						<input type="checkbox"/>	<input type="checkbox"/>
Micro_out[7]	WORD						<input type="checkbox"/>	<input type="checkbox"/>
Micro_out[8]	WORD						<input type="checkbox"/>	<input type="checkbox"/>
Micro_out[9]	WORD						<input type="checkbox"/>	<input type="checkbox"/>

Resultado dos testes

Leitura e Escrita via IO Scanning

Nome	Valor	Comentário	Estado	Tipo
leitura	<input type="checkbox"/>	WORD
leitura[1]	1	N/A	<input type="checkbox"/>	WORD
leitura[2]	2	N/A	<input type="checkbox"/>	WORD
leitura[3]	3	N/A	<input type="checkbox"/>	WORD
leitura[4]	4	N/A	<input type="checkbox"/>	WORD
leitura[5]	5	N/A	<input type="checkbox"/>	WORD
leitura[6]	6	N/A	<input type="checkbox"/>	WORD
leitura[7]	7	N/A	<input type="checkbox"/>	WORD
leitura[8]	8	N/A	<input type="checkbox"/>	WORD
leitura[9]	9	N/A	<input type="checkbox"/>	WORD
leitura[10]	10	N/A	<input type="checkbox"/>	WORD
leitura_RV	<input type="checkbox"/>	WORD
escrita	<input type="checkbox"/>	WORD
escrita[1]	70	N/A	<input type="checkbox"/>	WORD
escrita[2]	71	N/A	<input type="checkbox"/>	WORD
escrita[3]	72	N/A	<input type="checkbox"/>	WORD
escrita[4]	73	N/A	<input type="checkbox"/>	WORD
escrita[5]	74	N/A	<input type="checkbox"/>	WORD
escrita[6]	75	N/A	<input type="checkbox"/>	WORD
escrita[7]	76	N/A	<input type="checkbox"/>	WORD
escrita[8]	77	N/A	<input type="checkbox"/>	WORD
escrita[9]	78	N/A	<input type="checkbox"/>	WORD
escrita[10]	79	N/A	<input type="checkbox"/>	WORD

Micro820

Nome	Valor	Tipo	Comentário
Micro820		T_Micro820	
Micro820.Freshness	1	BOOL	Global Freshness
Micro820.Freshness_1	1	BOOL	Freshness of Object
Micro820.Inputs		T_Micro820_IN	Input Variables
Micro820.Inputs.MICRO_IN		ARRAY[0..9] OF WORD	
Micro820.Inputs.MICRO_IN[0]	1	WORD	
Micro820.Inputs.MICRO_IN[1]	2	WORD	
Micro820.Inputs.MICRO_IN[2]	3	WORD	
Micro820.Inputs.MICRO_IN[3]	4	WORD	
Micro820.Inputs.MICRO_IN[4]	5	WORD	
Micro820.Inputs.MICRO_IN[5]	6	WORD	
Micro820.Inputs.MICRO_IN[6]	7	WORD	
Micro820.Inputs.MICRO_IN[7]	8	WORD	
Micro820.Inputs.MICRO_IN[8]	9	WORD	
Micro820.Inputs.MICRO_IN[9]	10	WORD	
Micro820.Outputs		T_Micro820_OUT	Output Variables
Micro820.Outputs.Micro_out		ARRAY[0..9] OF WORD	
Micro820.Outputs.Micro_out[0]	70	WORD	
Micro820.Outputs.Micro_out[1]	71	WORD	
Micro820.Outputs.Micro_out[2]	72	WORD	
Micro820.Outputs.Micro_out[3]	73	WORD	
Micro820.Outputs.Micro_out[4]	74	WORD	
Micro820.Outputs.Micro_out[5]	75	WORD	
Micro820.Outputs.Micro_out[6]	76	WORD	
Micro820.Outputs.Micro_out[7]	77	WORD	
Micro820.Outputs.Micro_out[8]	78	WORD	
Micro820.Outputs.Micro_out[9]	79	WORD	

M580

Comunicação via READ_VAR / WRITE_VAR (Explícita)

Configuração do M580

Configuração via READ_VAR/ WRITE_VAR

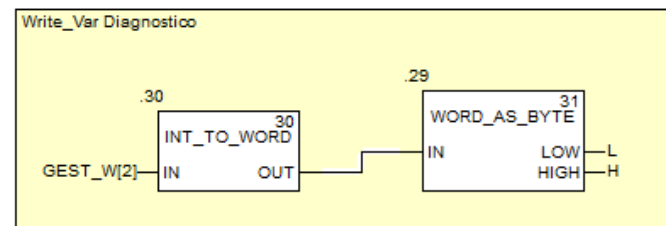
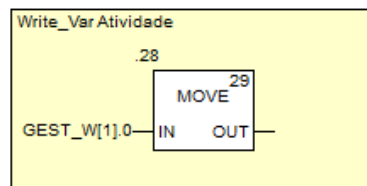
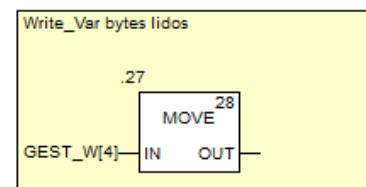
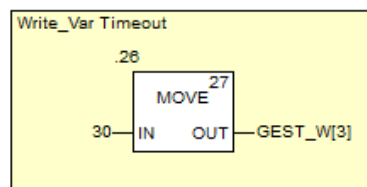
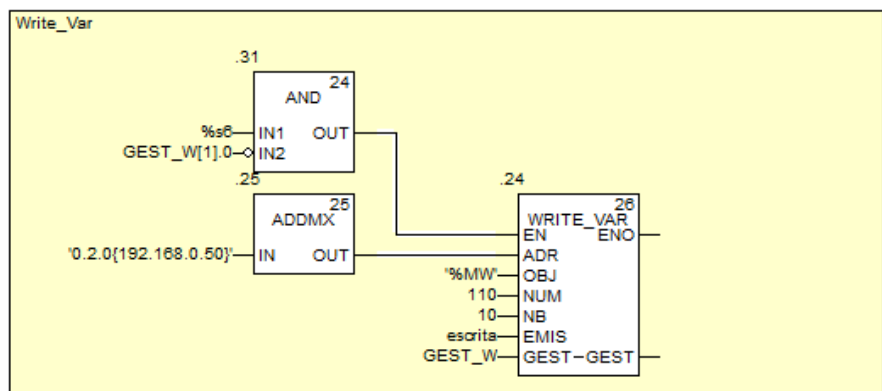
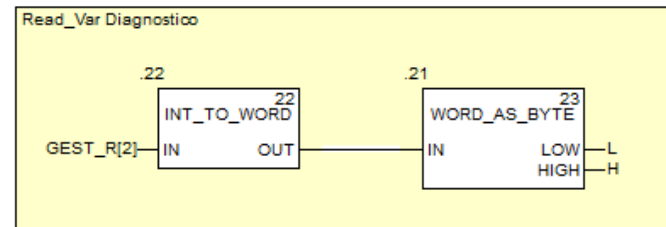
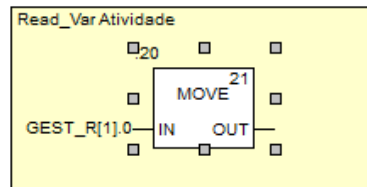
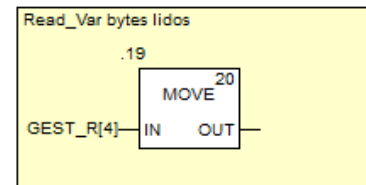
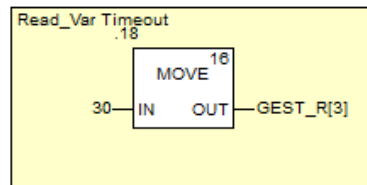
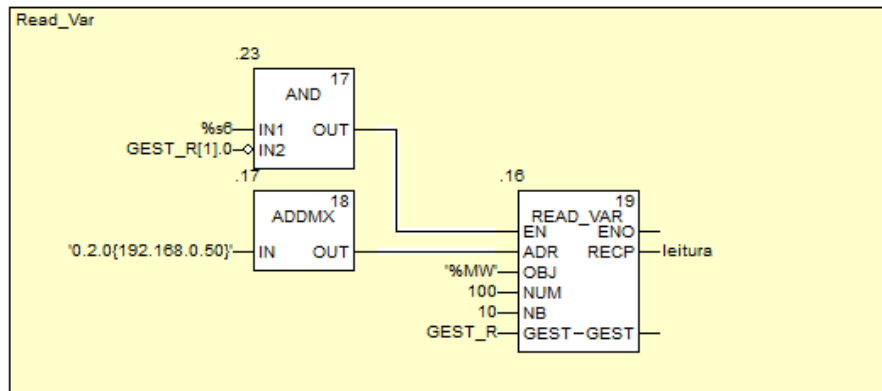

Resultado dos testes

Leitura e Escrita via READ_VAR/WRITE_VAR

Nome	Valor	Tipo	Comentário
leitura_RV
leitura_RV[1]	11	N/A	
leitura_RV[2]	12	N/A	
leitura_RV[3]	13	N/A	
leitura_RV[4]	0	N/A	
leitura_RV[5]	0	N/A	
leitura_RV[6]	0	N/A	
leitura_RV[7]	0	N/A	
leitura_RV[8]	0	N/A	
leitura_RV[9]	0	N/A	
leitura_RV[10]	0	N/A	
escrita
escrita_WV
escrita_WV[1]	50	N/A	
escrita_WV[2]	51	N/A	
escrita_WV[3]	52	N/A	
escrita_WV[4]	53	N/A	
escrita_WV[5]	54	N/A	
escrita_WV[6]	55	N/A	
escrita_WV[7]	56	N/A	
escrita_WV[8]	57	N/A	
escrita_WV[9]	58	N/A	
escrita_WV[10]	59	N/A	

Micro820

Nome	Valor	Tipo	Comentário
leitura
leitura[1]	11	INT	
leitura[2]	12	INT	
leitura[3]	13	INT	
leitura[4]	0	INT	
leitura[5]	0	INT	
leitura[6]	0	INT	
leitura[7]	0	INT	
leitura[8]	0	INT	
leitura[9]	0	INT	
leitura[10]	0	INT	
escrita
escrita[1]	50	INT	
escrita[2]	51	INT	
escrita[3]	52	INT	
escrita[4]	53	INT	
escrita[5]	54	INT	
escrita[6]	55	INT	
escrita[7]	56	INT	
escrita[8]	57	INT	
escrita[9]	58	INT	
escrita[10]	59	INT	

M580

Life Is On

Schneider
Electric

Life Is On

Schneider
Electric