

Dry-Type Transformers



Transformadores tipo seco

Transformateurs de type sec

1000 Volts and Below /

1 000 V y tensiones inferiores /

1000 V et moins

Instruction Bulletin / Boletín de instrucciones / Directives d'utilisation

43006-850-01

11/2015

Retain for future use. / Conservar para uso futuro. / À conserver pour usage ultérieur.



Dry-Type Transformers

1000 Volts and Below

Class 7400

ENGLISH

Instruction Bulletin
43006-850-01
Rev. 02, 11/2015
Retain for future use.



by Schneider Electric

Hazard Categories and Special Symbols

Read these instructions carefully and look at the equipment to become familiar with the device before trying to install, operate, service, or maintain it. The following special messages may appear throughout this bulletin or on the equipment to warn of hazards or to call attention to information that clarifies or simplifies a procedure.



The addition of either symbol to a “Danger” or “Warning” safety label indicates that an electrical hazard exists which will result in personal injury if the instructions are not followed.



This is the safety alert symbol. It is used to alert you to personal injury hazards. Obey all safety messages that follow this symbol to avoid possible injury or death.

⚠ DANGER

DANGER indicates an imminently hazardous situation which, if not avoided, **will result in** death or serious injury.

⚠ WARNING

WARNING indicates a potentially hazardous situation which, if not avoided, **can result in** death or serious injury.

⚠ CAUTION

CAUTION indicates a potentially hazardous situation which, if not avoided, **can result in** minor or moderate injury.

NOTICE

NOTICE is used to address practices not related to physical injury. The safety alert symbol is not used with this signal word.

NOTE: Provides additional information to clarify or simplify a procedure.

Please Note

Electrical equipment should be installed, operated, serviced, and maintained only by qualified personnel. No responsibility is assumed by Schneider Electric for any consequences arising out of the use of this material.

Table of Contents

SECTION 1: INTRODUCTION	6
SECTION 2: SAFETY PRECAUTIONS CODES AND STANDARDS	8
Disclaimer Statement	8
SECTION 3: RECEIVING, HANDLING AND STORING	0
Receiving	10
Handling	10
Handling with Platform Dollies or Lifts, Pallet Jacks or Fork Trucks	10
Handling with Cranes: Using Cables, Chains or Straps	11
Handling Enclosure Styles D, H and K after Removal of the Shipping Pallet	14
Storing	14
SECTION 4: INSTALLATION	16
Locating/Placing Ventilated and Non-ventilated Transformers	16
All Enclosure Styles (D, E, F, H, K and J)	19
Grounding	23
Seismic Qualifications	24
Sound/Vibration Control	24
Enclosure Style K	25
Enclosure Styles D, E, H and J	25
Making Electrical Connections	26
Pre-commissioning/Pre-energizing Checks and Testing	30
Cleaning	30
Visual and Mechanical Checks	30
Electrical Testing	31
SECTION 5: OPERATION	33
Effects of Humidity	33
Enclosure Temperature	34
Prior to Energizing the Transformers	34
Energizing the Transformer	34
SECTION 6: MAINTENANCE	37
Performing Visual and Mechanical Checks	37
Frequency	37
Severe, Environmental or Special Events	38
Cleaning	38
Connections and Contact Surfaces	38
Enclosures, Windings and Insulators	38
Performing Electrical Testing	38
Contact Resistance	39
Insulation Resistance	39
Winding Resistance	39
Grounding and Bonding	39
Turns Ratio	39
Sound Isolation Pads	40
Coil Cooling Ducts	40
Terminals	40
SECTION 7: REPLACEMENT PARTS AND ACCESSORIES	41

List of Figures

Figure 1:	Energy Efficient 2016 Transformers (EX)	6
Figure 2:	Energy Efficient 2016 Transformers (EX)	6
Figure 3:	Open Core and Coil	7
Figure 4:	Energy Efficient (EE) Ventilated Transformer	7
Figure 5:	Non-Linear (NL, NP, NLP) and Harmonic Mitigating (HM)	7
Figure 6:	Non-ventilated Transformer	7
Figure 7:	Handling with a Fork Truck: Blades/Forks Placed under the Entire Transformer (Shipping Pallet Attached)	10
Figure 8:	Two-Point Lift: Cable Pull Angles (Not Less than 60 Degrees from Horizontal)	11
Figure 9:	Two-Point Lift: Handling with Chains, Hooks and Cross Corners (Not Less than 60 Degrees from Horizontal)	12
Figure 10:	Four-Point Lift: Handling with Chains, Hooks and Four Corners (Not Less than 60 Degrees from Horizontal)	13
Figure 11:	Four-Point Lift: Handling with a Strap and Hooks (Not Less than 60 Degrees from Horizontal)	13
Figure 12:	Handling with a Pallet Jack: Enclosure Styles D, E, H and K after Removing the Shipping Pallet	14
Figure 13:	Sample Nameplate	16
Figure 14:	Minimum Distance Marked on Nameplate NEC 450.9	17
Figure 15:	Mounting: Enclosure Styles D, H, K, and E	17
Figure 16:	Enclosure D, H, K, and E	17
Figure 17:	Mounting Enclosure Style J: Ventilated	18
Figure 18:	Floor Mounting Bracket: Enclosure Style K	18
Figure 19:	Floor Mounting Bracket: Enclosure Style K	18
Figure 20:	Transformers Installed Indoors: NEC 450.21 Exceptions A or B from Sample Nameplate	19
Figure 21:	Wall mounted transformer	20
Figure 22:	Trapeze (Ceiling) mounted transformer	21
Figure 23:	Type 3R Enclosure Kits	22
Figure 24:	Four-conductor Ground Terminal Bar	23
Figure 25:	Loosening the Nut One Full Turn (Four Places) Label	24
Figure 26:	Floating the Transformer on the Isolation Pads/Sound Damper	24
Figure 27:	Enclosure Style K: Bolts Accessible from the Front of the Transformer	25
Figure 28:	Access Point: Enclosure Styles D, E, H and K	26
Figure 29:	Access Point: Enclosure Style J	27
Figure 30:	Label to Show Top Location on Enclosures (Access Points Below the Top Terminal Board)	27
Figure 31:	Phase Diagram, Tap Locations and Voltage Rating Marked on Nameplate	28
Figure 32:	Caution Label for Delta Wye or Wye Delta Connected Transformers	29
Figure 33:	Removing Temporary Braces	34
Figure 34:	Exploded Assembly for EX75T3H Energy Efficient Transformer with Enclosure Style 20K Front	41
Figure 35:	Exploded Assembly for EX300T3H Energy Efficient Transformer with Enclosure Style 25J Front	42
Figure 36:	Sample Nameplates	44

List of Tables

Table 1:	Enclosure Clearances	19
Table 2:	Converting from Floor to Wall Mounting (using factory kits)	20
Table 3:	Converting from Floor to Trapeze (Ceiling) Mounting (using factory kits)	21
Table 4:	Covers, Side Panels, Weather Shields and Mounting Brackets.....	43
Table 5:	VERSAtile™ Compression Lugs and Mechanical Set-Screw Types—UL Listed Lugs AL9CU	44
Table 6:	Square D Lug Kits for Dry-type Transformers	45
Table 7:	Terminal Sizes, Mechanical and Compression Lugs and Wire Ranges.....	46
Table 8:	Square D Ground Bar Kits.....	46

ENGLISH

ENGLISH

Section 1—Introduction

This instruction bulletin provides installation, operation and maintenance instructions for dry-type transformers 1000 volts and below for use in commercial and industrial applications.

NOTE: This bulletin should be used only by qualified personnel.

The following dry-type transformer product families are included in this instruction bulletin. Typical transformers are shown in Figures 1–6.

- Low Voltage Distribution Transformers, Three-phase and Single-phase
 - General Purpose—50 and 60 Hz
 - Energy Efficient (EE)—60 Hz
 - Energy Efficient 2016 (EX)—60 Hz
 - Non-linear Offering (NL, NP or NLP)—50 and 60 Hz
 - Harmonic Mitigating Transformers (HM)—50 and 60 Hz
 - Open Core and Coil (OC)
- Drive Isolation Transformers (DIT)
- Non-ventilated Transformers (NV)

Figure 1: Energy Efficient 2016 Transformers (EX)



Figure 2: Energy Efficient 2016 Transformers (EX)



Figure 3: Open Core and Coil

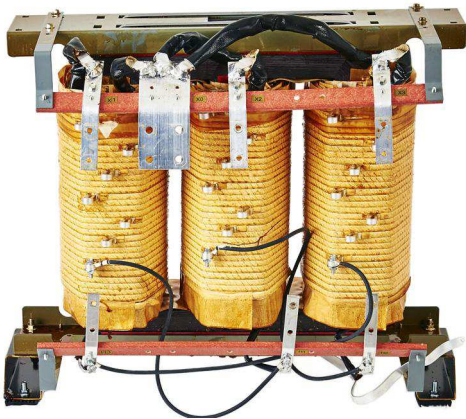

Figure 4: Energy Efficient (EE) Ventilated Transformer



Figure 5: Non-Linear (NL, NP, NLP) and Harmonic Mitigating (HM)



Figure 6: Non-ventilated Transformer



Section 2—Safety Precautions

⚠ DANGER
HAZARD OF ELECTRIC SHOCK, EXPLOSION, OR ARC FLASH
<ul style="list-style-type: none">• Apply appropriate personal protective equipment (PPE) and follow safe electrical work practices. See NFPA 70E, NOM-029-STPS-2011, or CSA Z462.• This equipment must be installed and serviced only by qualified electrical personnel.• Perform such work only after reading and understanding all of the instructions contained in this bulletin.• Turn off all power supplying this equipment before working on or inside equipment.• Always use a properly rated voltage sensing device to confirm power is off.• Before performing visual inspections, tests, or maintenance on this equipment, disconnect all sources of electric power. Assume all circuits are live until they are completely de-energized, tested, and tagged. Pay particular attention to the design of the power system. Consider all sources of power, including the possibility of backfeeding.• Always practice lock-out/tag-out procedures according to OSHA requirements.• Carefully inspect your work area, and remove any tools and objects left inside the equipment.• Replace all devices, doors, and covers before turning on power to this equipment.• All instructions in this manual are written with the assumption that the customer has taken these measures before performing maintenance or testing.
Failure to follow these instructions will result in death or serious injury.

Codes and Standards

It is the responsibility of the users of this document to use qualified electrical personnel and to comply with applicable federal, state and local electrical codes when installing electrical products and systems.

This document adheres to the codes and standards as outlined by the National Fire Protection Association® (NFPA). Refer to NFPA 70: 2014 Edition National Electrical Code (NEC®).

Disclaimer Statement

Electrical equipment should be installed, operated, serviced and maintained only by qualified personnel. No responsibility is assumed by Schneider Electric for any consequences arising out of the use of this material.

ENGLISH

Section 3—Receiving, Handling and Storing

Receiving

1. Upon receipt, remove the packaging.
 - Immediately inspect the new transformer for shipping damage.
 - Refer to Replacement Parts and Accessories on page 41 for replacement parts, accessories (e.g., touch-up paint) and spare parts for minor damage.
2. Check the packing list against the product nameplate.
 - Verify that the order and shipment align with each other and that the shipment is complete.

NOTE: Follow Schneider Electric Conditions of Sale for shortages and errors.
3. Repackage the transformers for storage if they are not to be installed immediately.
 - Cover all ventilation openings to protect against exposure to moisture, dust and contaminants.
 - Leave packing materials intact until the transformers are ready to install.
4. Refer to “Conditions of Sale” for details regarding claims for equipment shortages and other errors. Contact your local Schneider Electric distributor for additional assistance.

Handling

Handle transformers carefully to avoid damage. Avoid subjecting the transformers to impact, jolting, jarring and rough handling. Ensure that transformers are transported in the upright position. When possible, transport transformers to the installation site while still mounted on their shipping pallets.

Verify that the weight of the transformer does not exceed the rated capacity of the handling equipment to be used.

Handling with Platform Dollies or Lifts, Pallet Jacks or Fork Trucks

Extreme care should be exercised when moving transformers from the bottom. See Figure 7.

- Use care to distribute the weight when transporting transformers using platform dollies, platform lifts, pallet jacks or fork trucks.
- Use hand trucks or forklifts only when the blades or forks are long enough to pass completely under the transformer enclosure or shipping pallet. Wider fork separation is preferred to distribute the weight of the unit evenly for increased stability.

Figure 7: Handling with a Fork Truck: Blades/Forks Placed under the Entire Transformer (Shipping Pallet Attached)

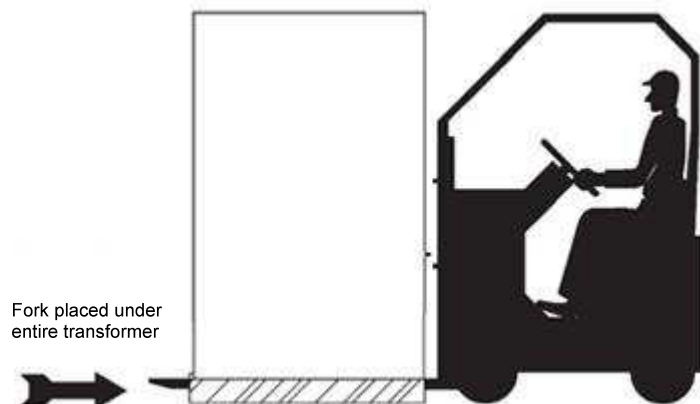

Handling with Cranes: Using Cables, Chains or Straps

When lifting the transformer from above, the use of spreader bars with cables or chains is permissible. This will help avoid damage to the enclosure or equipment.

The enclosure can be removed to allow the units to be transported through small openings, lifting as the same means as shown in Figure 8 on page 11, Figure 9 on page 12, and Figures 10 and 11 on page 13. Refer to Figures 34 and 35 in Replacement Parts and Accessories on page 41 for exploded views of parts and accessories.

Ensure that the lifting cable pull angles are not less than 60 degrees from horizontal. See Figure 8 on page 11.

Figure 8: Two-Point Lift: Cable Pull Angles (Not Less than 60 Degrees from Horizontal)

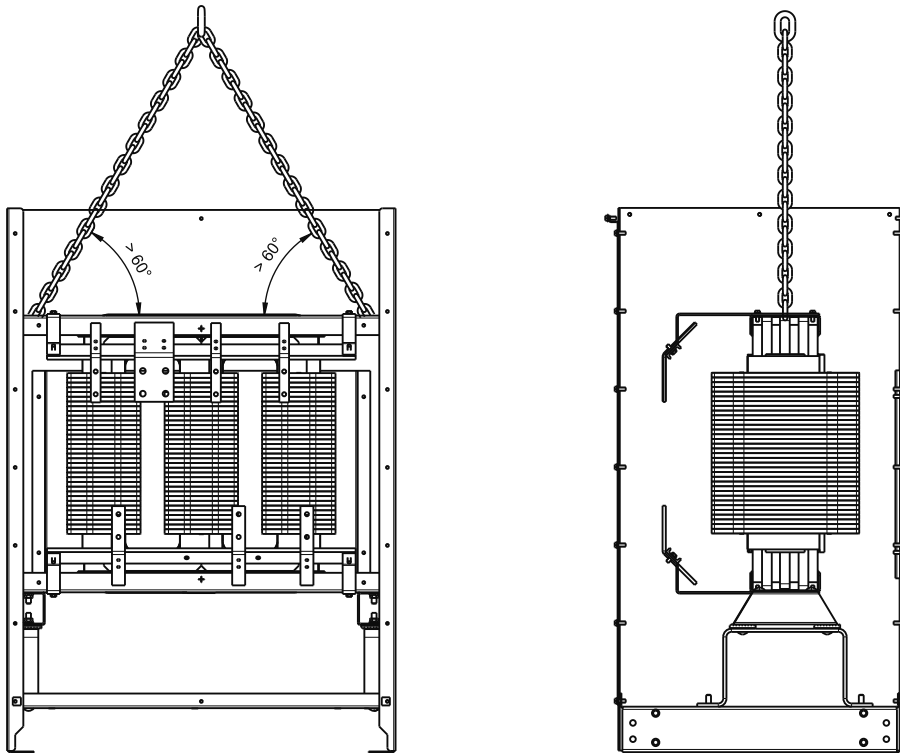

Refer to Figures 9 –11 on pages 12 – 13 for other permissible lifting and handling options.

Figure 9: Two-Point Lift: Handling with Chains, Hooks and Cross Corners (Not Less than 60 Degrees from Horizontal)

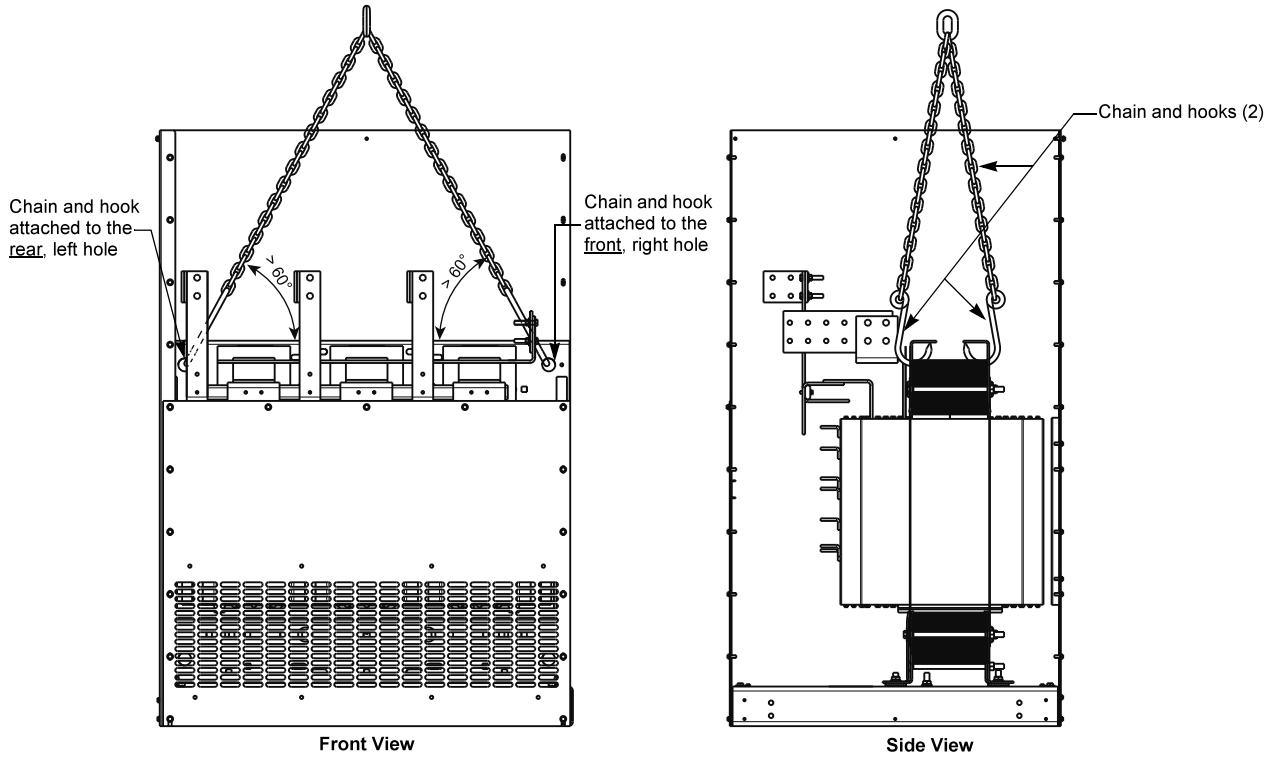

Two-point lift with chains and hooks: Top core bracket, right side and front hole. Rear bracket, left side and rear hole

Figure 10: Four-Point Lift: Handling with Chains, Hooks and Four Corners (Not Less than 60 Degrees from Horizontal)

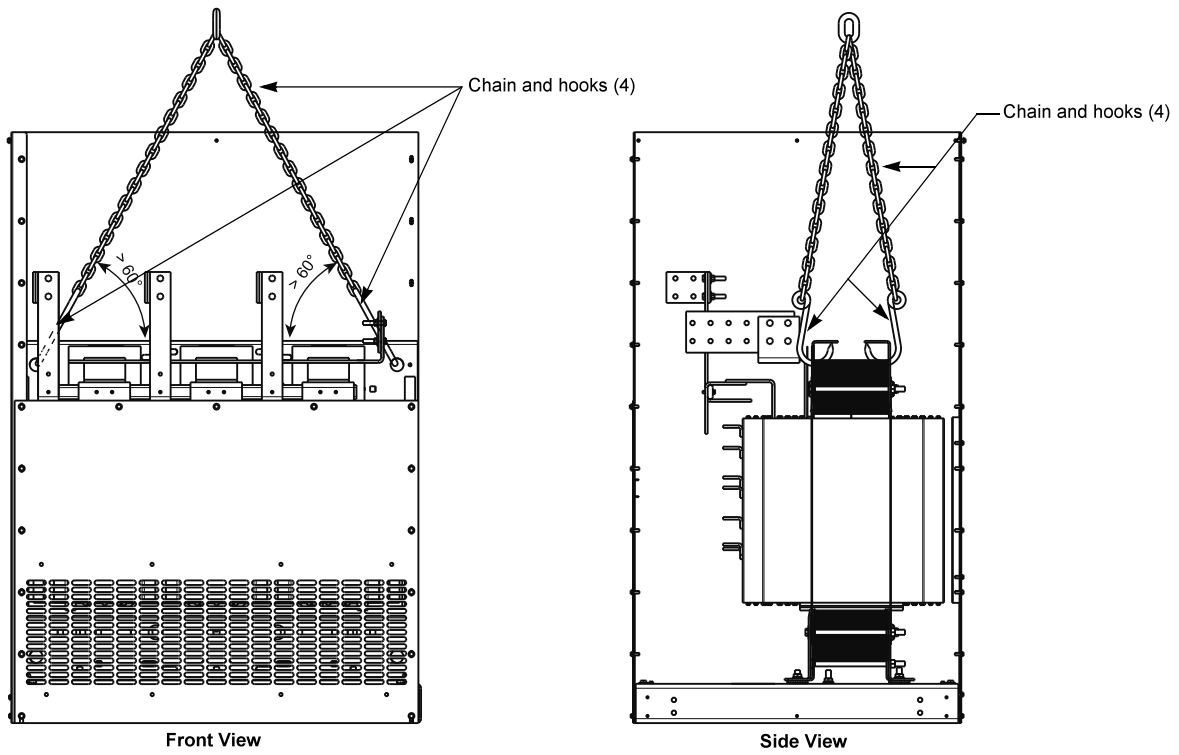

Four-point lift: The hooks are in the front and back holes of the core bracket (4), with chains lifting on the hooks.

Figure 11: Four-Point Lift: Handling with a Strap and Hooks (Not Less than 60 Degrees from Horizontal)

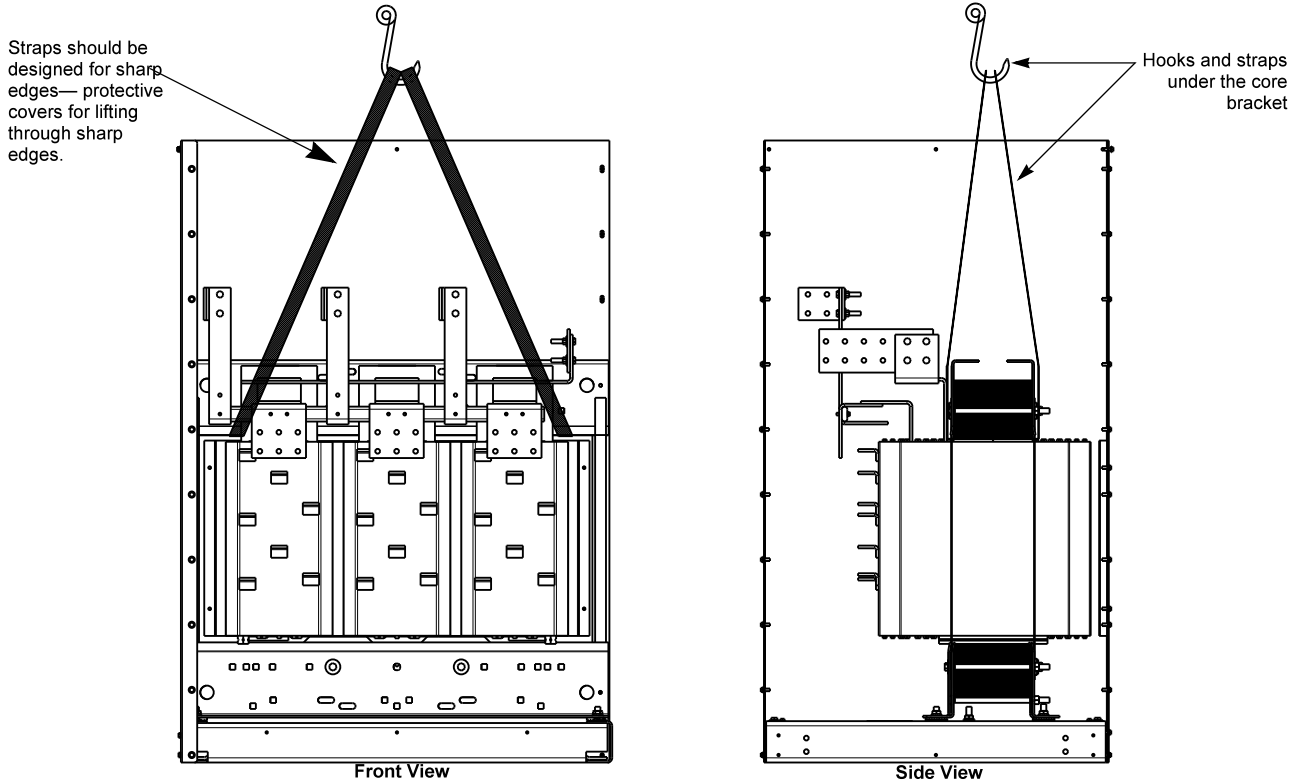

Four-point lift: The straps are under the core brackets, with the front-to-back straps coming together at the top with a hook. Use straps with protective cover, core clamp edges are sharp.

Handling Enclosure Styles D, H and K after Removal of the Shipping Pallet

Hand trucks and forklifts can access and move the transformer via the front and rear openings below the bottom of the base. See Figure 12. Follow the same handling instructions (beginning on page 10) as if the pallet is still attached.

Figure 12: Handling with a Pallet Jack: Enclosure Styles D, E, H and K after Removing the Shipping Pallet



Storing

Leave the packing material that encloses the transformer in place until the unit is ready for its final placement and wiring. This will help to protect the transformer enclosure and internal parts from dirt, water, moisture contamination and physical damage during storage. Provide extra measures to protect the transformer when the original packing material cannot be retained.

Store transformers indoors in a clean, dry, and heated building with uniform temperatures and adequate air circulation. If necessary, install electric heating to maintain a uniform temperature above the ambient temperature to prevent condensation.

Protect transformers from weather and contamination when it is not possible to store the transformers indoors.

Before energizing the transformer, complete the steps in Pre-commissioning/Pre-energizing Checks and Testing along with the following steps:

1. Test the insulation resistance if storage in a controlled environment was not feasible. Refer to Insulation Resistance on page 39.
2. Dry the unit if test levels are unacceptable:
 - a. Use two heaters or lamps per coil at 120 V, 50 W to apply external heat to the coils.
 - b. Mount the heater or lamp directly below the coils located at the front and rear of the core.



NOTE: Outdoor transformers are not weather resistant until they are properly and completely installed and energized. Treat outdoor transformers in exactly the same manner as indoor transformers until after they are installed.

Section 4—Installation

Locating/Placing Ventilated and Non-ventilated Transformers

1. Remove all packaging material. Keep the shipping pallet attached to the transformer to assist with moving the unit to its final installation location.
2. Verify that the nameplate matches the description from the building layout drawings (kVA, primary and secondary voltages, etc.). See Figure 13.

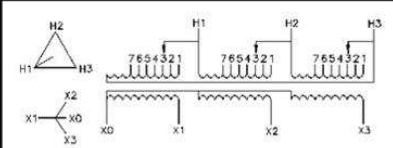
Figure 13: Sample Nameplate

		DRY TYPE DISTRIBUTION TRANSFORMER																																	
CAT. NO. : EX150T3H STYLE NO. : NHA1133203 SERIAL NO. : 006500502491 DATE CODE : 1523		KVA : 150 PHASE : 3 FREQ. : 60 % IZ : 4.1	PRI (H) VOLTS : 480 SEC (X) VOLTS : 208Y/120 PRI (H) AMPS : 180.42 SEC (X) AMPS : 416.36																																
WEIGHT : 1166 LBS. ENCL : 22K TYPE 2, TYPE 3R WHEN 7400WS22K INSTALLED TO BE IN ACCORDANCE WITH THE NATIONAL ELECTRIC CODE, ARTICLE 450.9, AND UL 1561, MAINTAIN MINIMUM CLEARANCE OF 0.5 INCH TO WALL OR OTHER OBSTRUCTIONS.		TYPE : SO INS CLASS : 220 °C EFFICIENCY : 98.83% @ 35% LOAD & 75 DEG C MEETS FINAL RULE U.S. 10 CFR 431 APR 2013	RISE : 150 °C AMB : 40 °C BASIC MODEL NO. : 065EX150T480D208Y2A-001																																
		<table border="1"> <thead> <tr> <th colspan="2">TAP POSITIONS</th> <th>TAP</th> <th>VOLTS</th> </tr> </thead> <tbody> <tr> <td>7</td> <td>6</td> <td>1</td> <td>502</td> </tr> <tr> <td></td> <td></td> <td>2</td> <td>491</td> </tr> <tr> <td>4</td> <td>5</td> <td>3</td> <td>480</td> </tr> <tr> <td></td> <td></td> <td>4</td> <td>469</td> </tr> <tr> <td></td> <td></td> <td>5</td> <td>458</td> </tr> <tr> <td></td> <td></td> <td>6</td> <td>442</td> </tr> <tr> <td>1</td> <td>2</td> <td>7</td> <td>431</td> </tr> </tbody> </table>		TAP POSITIONS		TAP	VOLTS	7	6	1	502			2	491	4	5	3	480			4	469			5	458			6	442	1	2	7	431
TAP POSITIONS		TAP	VOLTS																																
7	6	1	502																																
		2	491																																
4	5	3	480																																
		4	469																																
		5	458																																
		6	442																																
1	2	7	431																																
RWN		 POWER TRANSFORMER 127 H INS SYS. : 65PDG220-1 MADE IN THE U.S.A.																																	

3. Locate the unit per the building's layout drawing.
4. Verify the environment is suitable for the enclosure type.
5. Ensure the location is readily accessible to qualified personnel (per NEC 450.13). Units located in the open can be mounted on walls, columns, or otherwise supported from structures.
6. Ensure adequate ventilation since it is essential to properly cool ventilated transformers. Refer to National Electrical Code (NEC®) Article 450.
 - The minimum distance is marked on Nameplate NEC 450.9. See Figure 14 on page 17.
 - Minimum distance varies by enclosure style. See the approval drawing from Schneider Electric for minimum distance.
 - Clean, dry air is desirable.
 - Filtered air may reduce maintenance if the location of the transformer presents a problem.

Figure 14: Minimum Distance Marked on Nameplate NEC 450.9

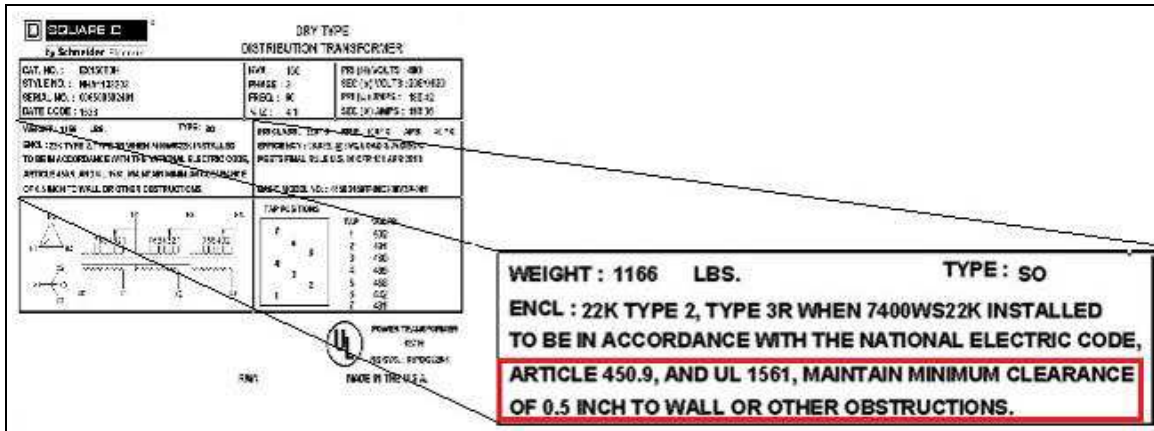

7. Mount any accessories prior to installing the transformer when using wall or ceiling (trapeze) mounting.
 - a. Observe the four mounting hole locations in each enclosure base.
 - b. Obtain the actual dimensions via approval drawings from Schneider Electric.
 - c. Secure the units using one of two mounting methods: without floor mounting brackets (Figures 15–16 and Figure 17 on page 18) or with floor mounting brackets (Figures 18 and 19 on page 18).
8. Place the transformer in final position.

Figure 15: Mounting: Enclosure Styles D, H, K, and E

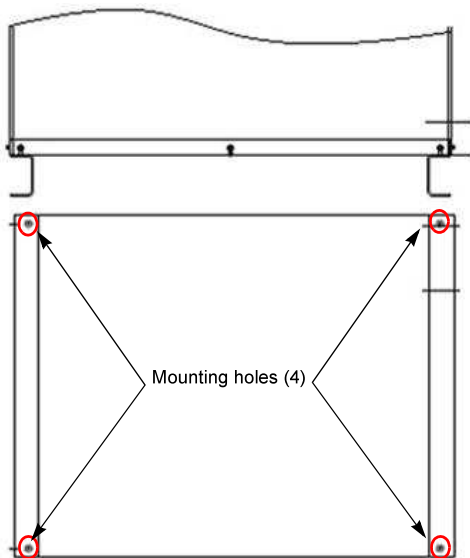

Figure 16: Enclosure D, H, K, and E

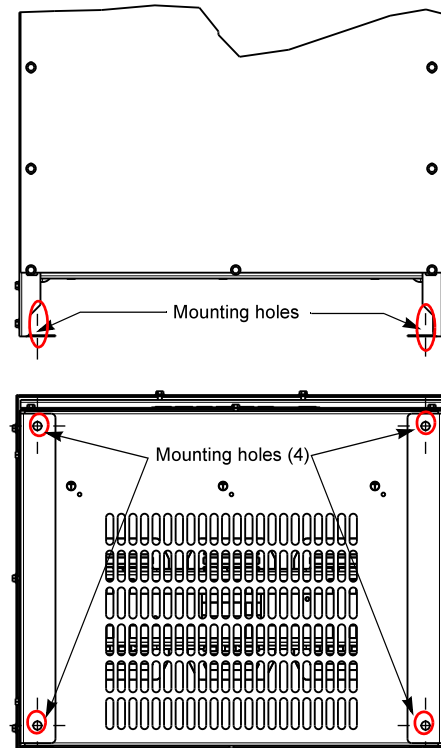
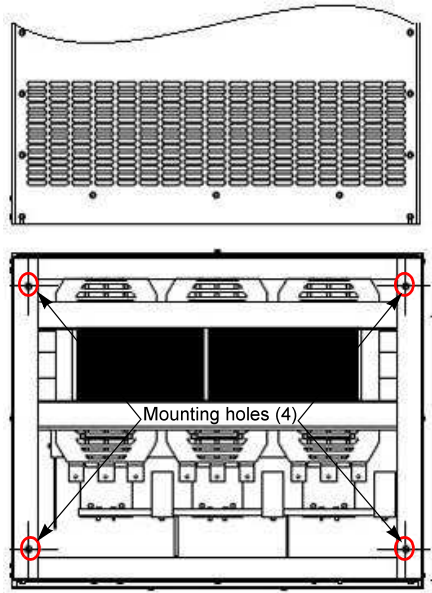

Figure 17: Mounting Enclosure Style J:
Ventilated



Units not for use on combustible floor (open bottom)

Figure 18: Floor Mounting Bracket: Enclosure Style K

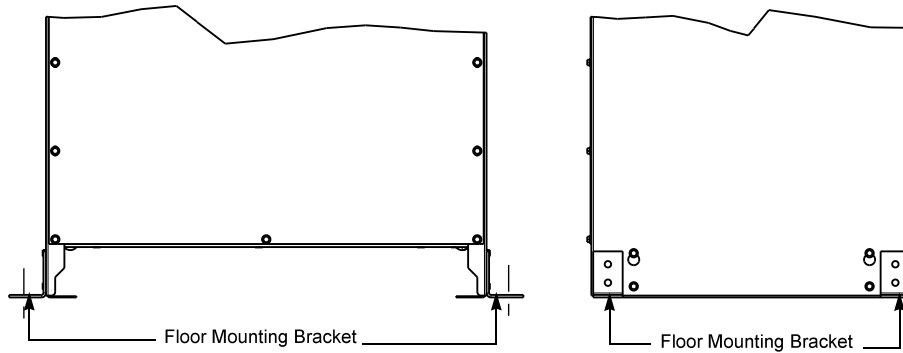
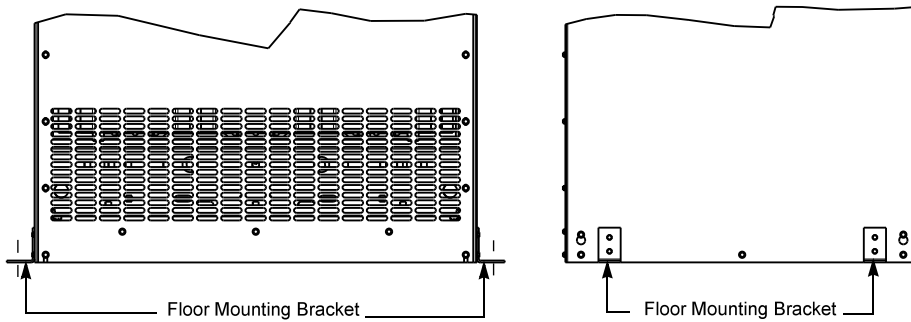

Figure 19: Floor Mounting Bracket: Enclosure Style K



All Enclosure Styles (D, E, F, H, K and J)

- Transformers Installed Indoors (Styles D, E, F, H, K and J):
 - Completely enclosed or completely enclosed with ventilated openings; complies with NEC 450.21 (A) Exception
 - Units greater than 112.5 kVA
 - Have 428°F (220°C) or 392°F (200°C) insulation systems; complies with 450.21 (B) Exception No. 2

See Figure 20.

Figure 20: Transformers Installed Indoors: NEC 450.21 Exceptions A or B from Sample Nameplate

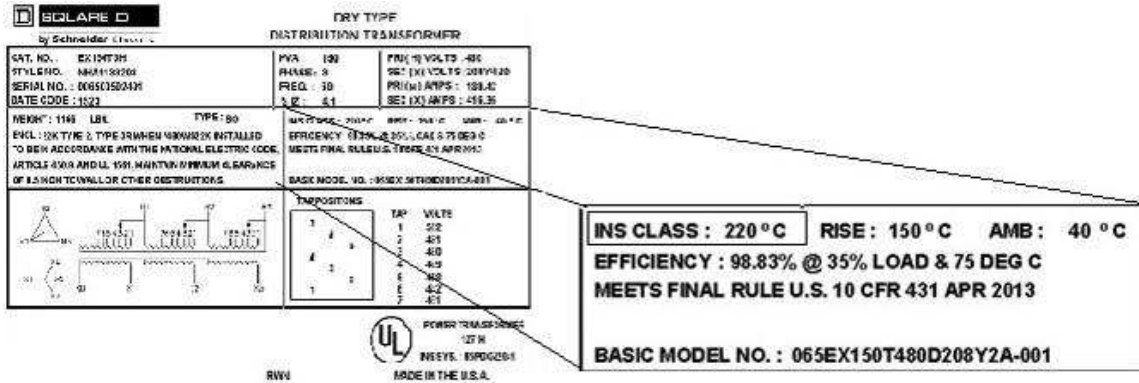

Table 1: Enclosure Clearances

Enclosure Style	Front Clearance	Side Clearance (in. / mm)	Rear Clearance (in. / mm)
D	Working Clearance for all styles vary substantially depending on voltage and specific application. Refer to NEC 110.26	0.50 / 12.7	Type EE – 3 / 76.2 All other styles – 6 / 152
H			3 / 76.2
E			3 / 76.2
K			0.50 / 12.7
J			0.50 / 12.7
F			12 / 305

Transformers can be converted from Floor to Wall mounted (See Table 2 below and Figure 21 on page 20) or Floor to Trapeze mounted (See Table 3 and Figure 22 on page 21) using factory available kits. The kits are pre-punched to align with enclosure mounting holes; and, when the transformer is installed, holds the minimum clearance for the units. New Style K wall mounting bracket allows for 6 in. (152 mm) and 3 in. (76 mm) clearances, all other styles require a 6 in. (152 mm) clearance.

The factory kits do not include hardware, hardware must be supplied by the customer. Hardware includes the thread rod for trapeze mounting the transformers. The designer of record must size and choose the anchors and hardware because of the large variety of construction materials and techniques. Schneider Electric can not advise on the anchoring, the wall mounting, or sizing of rods for trapeze mounting.

Table 2: Converting from Floor to Wall Mounting (using factory kits)

Enclosure Style	Enclosure Number	Maximum Weight (lb. / kg)
D	17 – 20	700 / 317
H	17 – 18	700 / 317
E	17 – 20	700 / 317
K	17 – 20	850 / 386

Figure 21: Wall mounted transformer

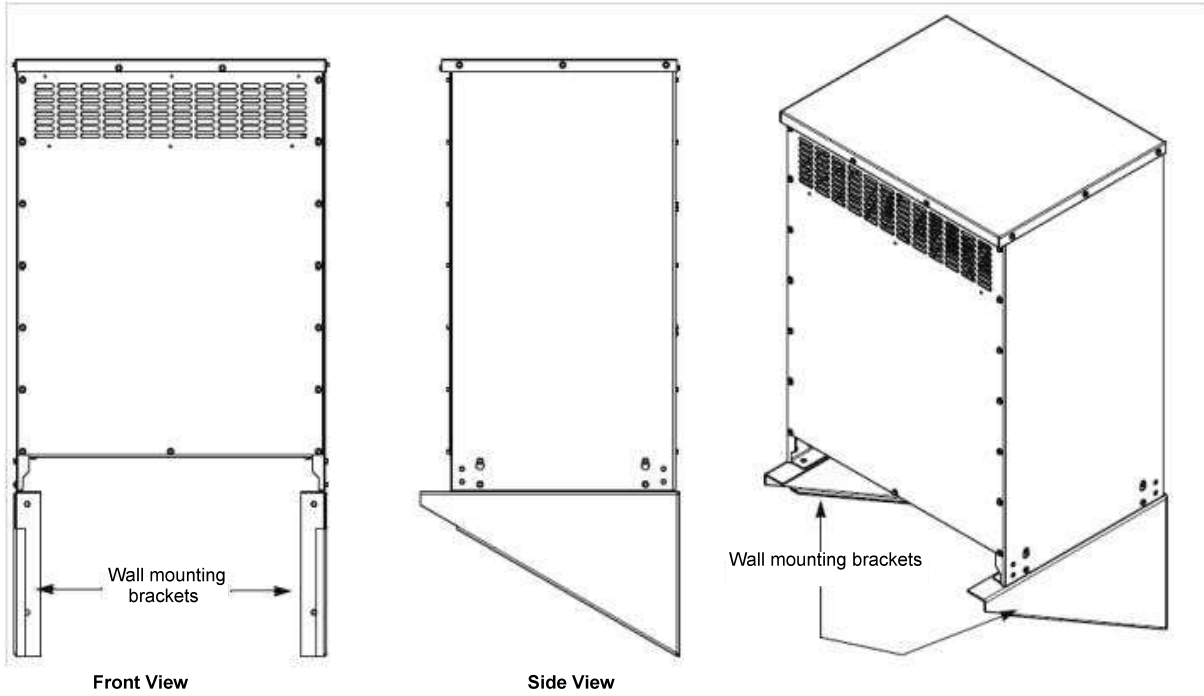
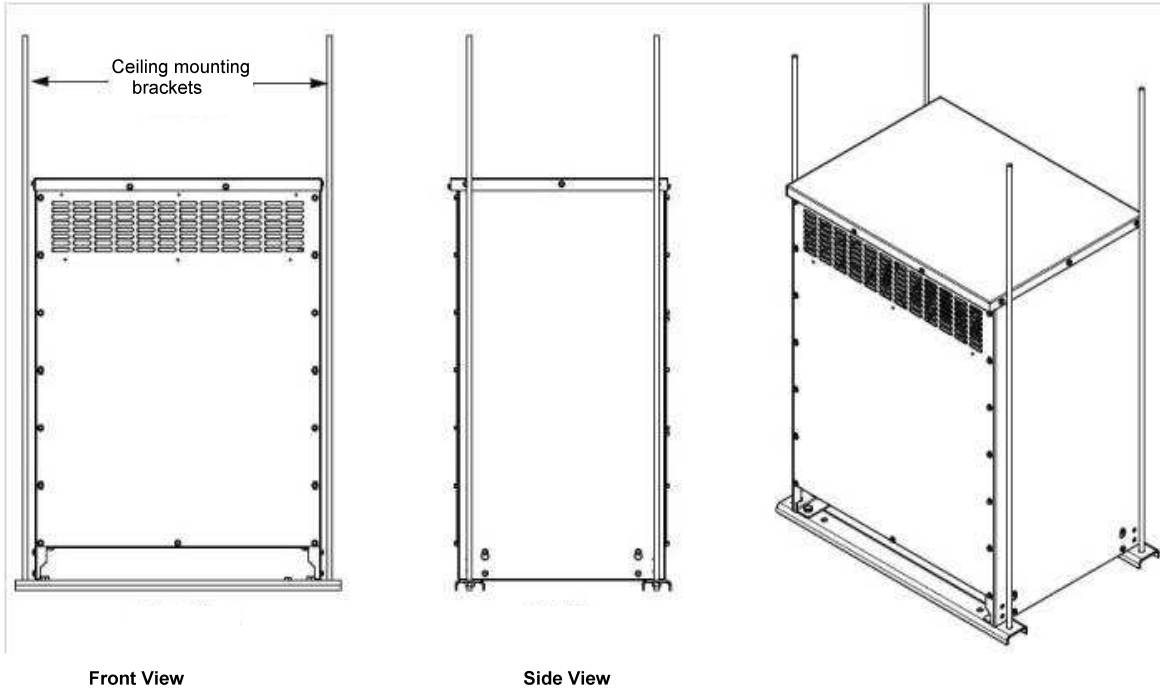

Table 3: Converting from Floor to Trapeze (Ceiling) Mounting (using factory kits)

Enclosure Style	Enclosure Number	Maximum Weight (lb. / kg)
D	17 – 24	1200 / 544
H	17 – 18	1200 / 544
E	17 – 22	1200 / 544
K	17 – 22	1200 / 544

Figure 22: Trapeze (Ceiling) mounted transformer



Enclosure D, E, H, K, J can be converted to Type 3R using field installed kits. See Figure 23 on page 22.

Type F enclosure – must be factory order if installed outdoors.

Figure 23: Type 3R Enclosure Kits

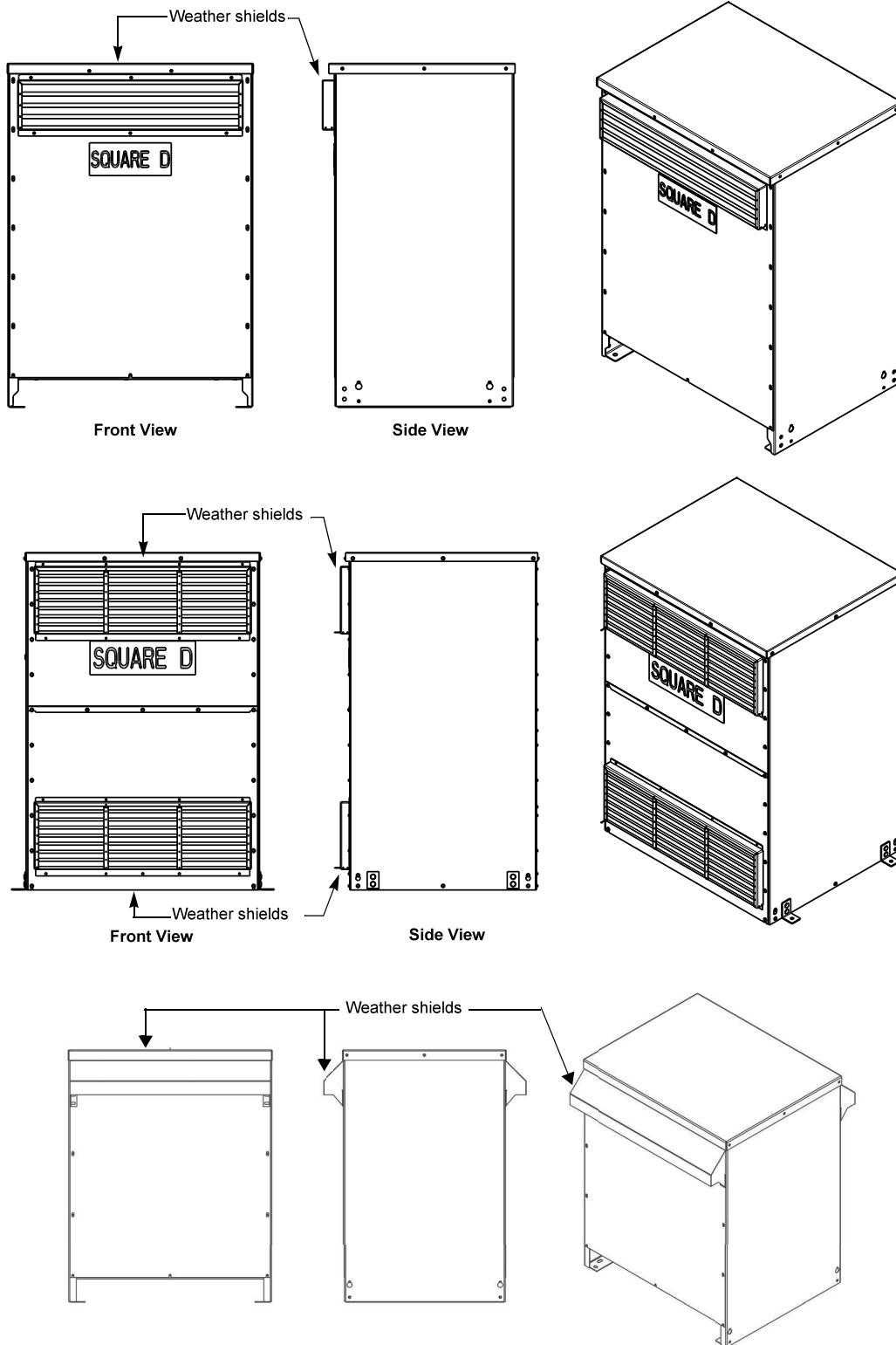

Grounding

1. Permanently and adequately ground the enclosure and core assembly of dry-type transformers in accordance with NEC requirements.
 - Windings may be grounded with consideration given to local conditions and in accordance with the NEC.
 - The ground terminal bar must be UL listed for this purpose.
 - In accordance with NEC 450.10, the terminal bar shall be bonded to the enclosure in accordance with NEC 250.12 and shall not be installed on or over any ventilated openings.
2. Connect the transformer, related accessories and components to ground in accordance with NFPA 70 (NEC).
3. Terminate all grounding and bonding conductors at a common equipment ground point on the enclosure.
4. Remove paint from around the area where the ground terminal bar is mounted to increase contact with enclosure parts.
 - Enclosure Styles D, E and H: An area is available in the transformer's base to drill and mount the ground terminal bar.
 - Enclosure Style K: Three pre-drilled holes are stamped ground to mount the ground terminal bar.
 - Enclosure Style J: Two pre-drilled holes are stamped ground to mount the ground terminal bar.

Square D brand secondary lug kits include a four-conductor ground terminal bar. The bar can also be obtained as a separate device from Schneider Electric. Refer to Table 6 on page 45 and see Figure 24.

Figure 24: Four-conductor Ground Terminal Bar

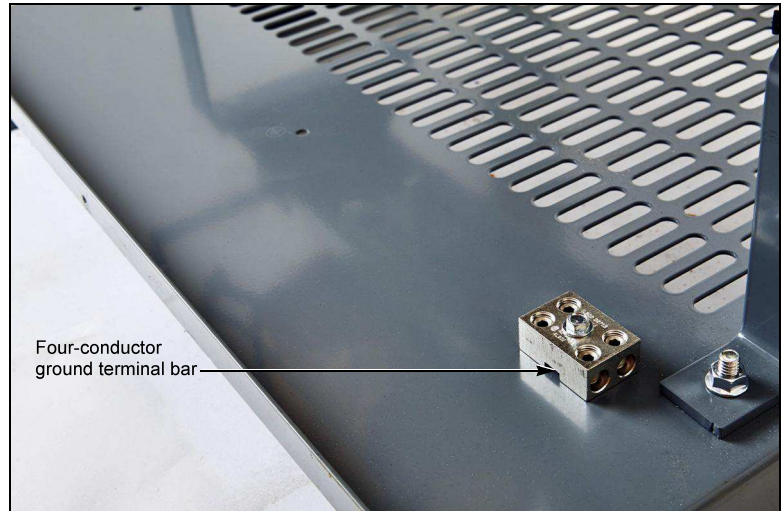

Seismic Qualifications

Seismic limits for dry-type low voltage transformers are obtained from tri-axle shake table test results that are conducted in accordance with the AC156 test protocol. Certifications are based on the location where units are installed and building codes governing the installation.

Building codes results are available for CBC 2001, CBC 2007, CBC 2010, IBC 2000, IBC 2003, IBC 2006, IBC 2009, NBC 2005, NBCC 2005, NBCC 2010, NFPA 5000, UBC 94, CBC 95, UBC97 and UFC 3-310-04.

Contact your local Schneider Electric distributor, or call 1-888-Square D (1-888-778-2733) to obtain the specific level of Sds, z/h and Ip for each enclosure style.

The levels supplied are based on the units being mounted and the notes on the approval drawings of each part number. Drawings are available that include mounting dimensions, mounting hole dimensions, overall dimensions, unit weight and approximate center of gravity location to assist in a seismic qualification. Contact your local Schneider Electric distributor, or call 1-888-Square D (1-888-778-2733) to obtain these drawings.

Other parties are responsible for detailing the equipment connection and anchorage requirements (including the lateral restraint system, if appropriate) for the given transformer installation. The installer and manufacturers of the anchorage and lateral restraint system are responsible for ensuring that the mounting requirements are met.

Sound/Vibration Control

The transformer has been designed to minimize the amount of audible sound produced. Sound isolation pads are secured between the transformer mounting bracket and the enclosure using bolts and nuts. The mounting hardware is tightened prior to shipment to prevent damage.

Loosen the nut one full turn to float the transformer on the isolation pads, thereby isolating the transformer from the enclosure. This will reduce audible sound levels even further. See Figures 25 and 26.

Figure 25: Loosening the Nut One Full Turn (Four Places) Label

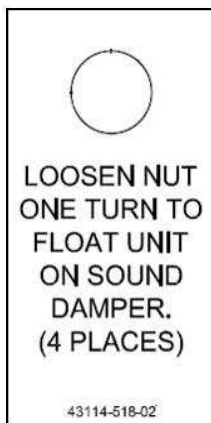
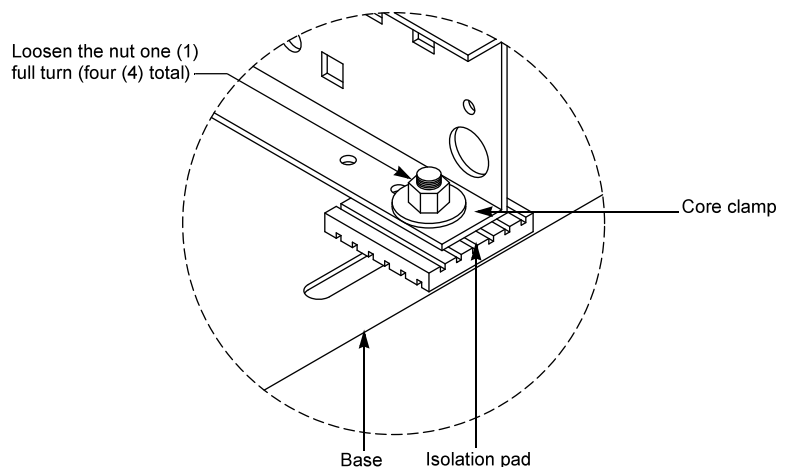

Figure 26: Floating the Transformer on the Isolation Pads/Sound Damper



In addition, the area where the transformer is located can affect the sound level:

- ❑ Try to avoid installing the transformer in a corner, narrow hall or in an area with smooth surfaces. Doing so can result in the sound being reflected and amplified.
- ❑ Securely fasten all the enclosure panels. Loose panels can result in rattling, thereby increasing the sound produced.
- ❑ Use flexible conduit, if possible.
- ❑ Ensure that the type of structure on which the transformer is mounted is strong enough to support the weight of the transformer.

Enclosure Style K

Enclosure Style K bolts are accessible from the front with an extension. See Figure 27.

Figure 27: Enclosure Style K: Bolts Accessible from the Front of the Transformer



Enclosure Styles D, E, H and J

Enclosure Styles D, E, H and J bolts are accessible from the front. See Figure 26 on page 24 for the access for these enclosures.

Making Electrical Connections

- ❑ Use flexible raceways, conduits and connectors, when possible, as attachments to transformer enclosures. This will help to reduce audible noise generation.
- ❑ Adhere to NFPA 70 (NEC) and minimum wire bending space requirements for the transformer enclosure. As an industry standard, bundle associated phase, neutral and equipment grounding conductors together within the transformer enclosure.
- ❑ Always use a calibrated torque wrench to tighten electrical connectors and terminals. For additional guidance, refer to Standard UL468A.
- ❑ Ensure that raceways, conduits and connectors enter the enclosure only in an area shown on the drawings. Access points for each enclosure style are listed below:
 - Enclosure Style D: (See Figure 28)
 - Front section of the transformer
 - Side and bottom access
 - Enclosure Style E: (See Figure 28)
 - Front section of the transformer
 - Side and bottom access
 - Enclosure Style H: (See Figure 28)
 - Front section of the transformer
 - Side and bottom access
 - Enclosure Style K: (See Figure 28)
 - Front section of the transformer
 - Side and bottom access

Figure 28: Access Point: Enclosure Styles D, E, H and K

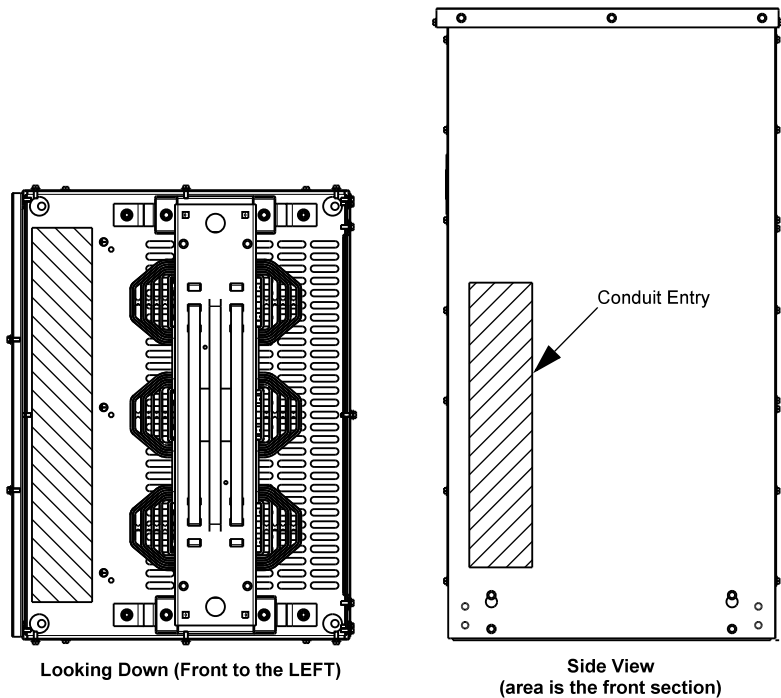

- Enclosure Style F:
 - Bottom section of the transformer
 - Air connection chambers offered if side access is needed
- Enclosure Style J: (See Figure 29)
 - Front section of the transformer
 - Side access
 - Open bottom access front to the core clamps

Figure 29: Access Point: Enclosure Style J

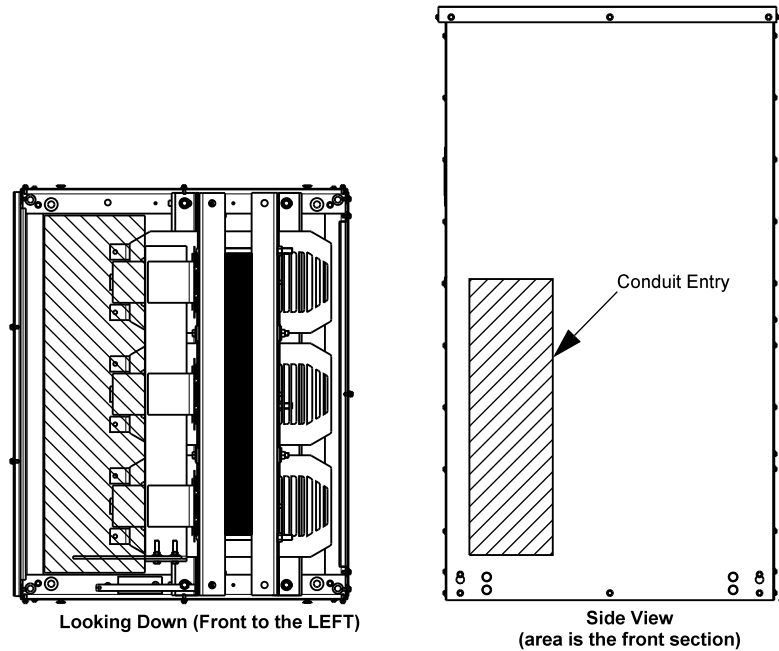

- Keep all access points below the top terminal board to prevent heat from exiting through the raceways, conduits and connectors. The sticker will show this top location on all enclosure styles (also shown on drawings). See Figure 30.

Figure 30: Label to Show Top Location on Enclosures (Access Points Below the Top Terminal Board)

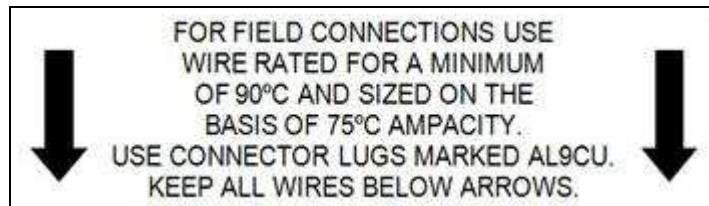

- ❑ Ensure that the side access complies with NEC 312.6 (A): Minimum Wire-Bending at Terminals. Bottom access must comply with NEC 312.6 (B): Minimum Wire-Bending Space at Terminals.
- ❑ Follow UL 1561 which requires that all lugs be suitable for 194°F (90°C). In addition, the conductors' temperature rating table must be 167°F (75°C) for the size to meet the current requirements of the overcurrent protection device and nameplate currents. Refer to Table 5 on page 44, Table 6 on page 45 and Table 7 on page 46 for a list of Square D lug kits, wire ranges by kVA and US voltage systems.
- ❑ Make sure that the contact surface is clean. This will minimize the possibility of a high resistance contact which could cause localized heating and possible premature failure. Refer to Connections and Contact Surfaces on page 38 for instructions to apply an approved electrical compound.
- ❑ Connect phases to proper terminals for proper motor-rotation. The phase diagram is shown on nameplate. The nameplate also shows the taps locations and voltage rating for each tap. See Figure 31.

Figure 31: Phase Diagram, Tap Locations and Voltage Rating Marked on Nameplate

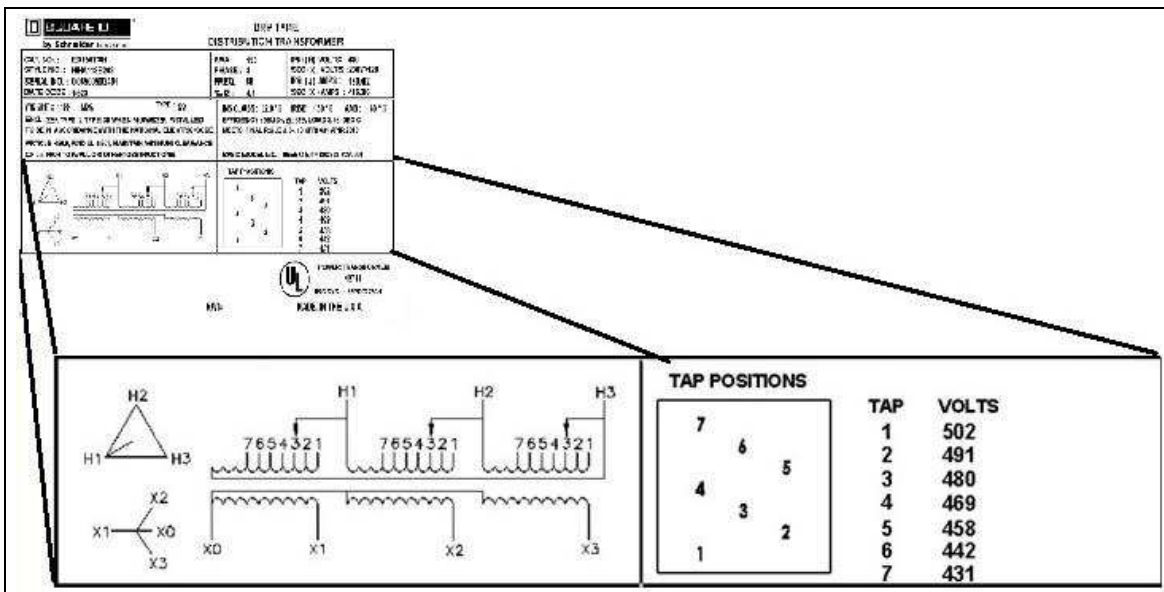

- ❑ Connecting the source of supply to the transformer secondary is permitted by NE C450.11 where the installation conforms to the manufacturer's instructions.

When the source of supply is connected to the transformer secondary, the inrush current will increase. The overcurrent device should be selected based on NEC 450.3(B) using the 250% allowance in order to reduce the potential for nuisance tripping during energization. Secondary overcurrent protection will be required.

For source of supply side connections to a WYE configured transformer winding, do not make any connections to the supply side HO or XO terminals. See Figure 32.

Figure 32: Caution Label for Delta Wye or Wye Delta Connected Transformers

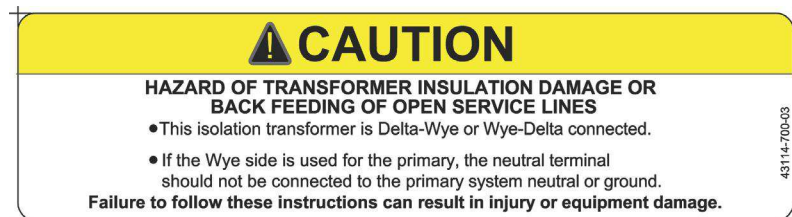

Pre-commissioning/Pre-energizing Checks and Testing

Cleaning

1. Ensure that all of the packing material, including any packing material used inside the enclosure of the transformer used to support and protect the unit during shipping, have been removed.
2. Vacuum away as much dust as possible. Dust will act as a thermal insulating material which will increase the temperature of the unit and could possibly decrease operational life. Refer to Cleaning on page 38.

Visual and Mechanical Checks

Perform the following visual and mechanical checks below. In addition, refer to Performing Visual and Mechanical Checks on page 37 for a detailed listing of instructions.

- Visually inspect the transformer for physical damage. Repair any physical damage, if possible, and provide suitable protective barriers to prevent future damage.
- Compare the transformer nameplate information with the drawings and/or specifications for the installation.
- Verify proper connection of the taps in accordance with the nameplate information.
- Check the clearance of all electrical connections. Verify all connections for tightness with a calibrated torque wrench.
- Visually check the core, frame, enclosure, conduits, raceways and conductors for proper ground bonding. In addition, refer to Grounding and Bonding on page 39.

Electrical Testing

⚠ DANGER

HAZARD OF ELECTRIC SHOCK, EXPLOSION, OR ARC FLASH

- Apply appropriate personal protective equipment (PPE) and follow safe electrical work practices. See NFPA 70E, NOM-029-STPS-2011, or CSA Z462.
- This equipment must be installed and serviced only by qualified electrical personnel.
- Perform such work only after reading and understanding all of the instructions contained in this bulletin.
- Turn off all power supplying this equipment before working on or inside equipment.
- Always use a properly rated voltage sensing device to confirm power is off.
- Always practice lock-out/tag-out procedures according to OSHA requirements.
- Carefully inspect your work area, and remove any tools and objects left inside the equipment.
- Replace all devices, doors, and covers before turning on power to this equipment.
- All instructions in this manual are written with the assumption that the customer has taken these measures before performing maintenance or testing.

Failure to follow these instructions will result in death or serious injury.

Refer to Maintenance on page 37 to perform the following pre-commissioning electrical testing:

- ❑ Measure contact resistance using a low resistance ohmmeter. Refer to Contact Resistance on page 39.
- ❑ Perform insulation resistance tests with an appropriate device. Refer to Insulation Resistance on page 39.
- ❑ Perform a turns ratio test on all taps and on the full winding voltages for each phase. Refer to Turns Ratio on page 39.
- ❑ Measure and record the winding resistances on larger transformers (>500 kVA). Refer to Winding Resistance on page 39.

Section 5—Operation

⚠ DANGER

HAZARD OF ELECTRIC SHOCK, EXPLOSION, OR ARC FLASH

- Apply appropriate personal protective equipment (PPE) and follow safe electrical work practices. See NFPA 70E, NOM-029-STPS-2011, or CSA Z462.
- This equipment must be installed and serviced only by qualified electrical personnel.
- Perform such work only after reading and understanding all of the instructions contained in this bulletin.
- Turn off all power supplying this equipment before working on or inside equipment.
- Always use a properly rated voltage sensing device to confirm power is off.
- Before performing visual inspections, tests, or maintenance on this equipment, disconnect all sources of electric power. Assume all circuits are live until they are completely de-energized, tested, and tagged. Pay particular attention to the design of the power system. Consider all sources of power, including the possibility of backfeeding.
- Always practice lock-out/tag-out procedures according to OSHA requirements.
- Carefully inspect your work area, and remove any tools and objects left inside the equipment.
- Replace all devices, doors, and covers before turning on power to this equipment.
- All instructions in this manual are written with the assumption that the customer has taken these measures before performing maintenance or testing.

Failure to follow these instructions will result in death or serious injury.

Effects of Humidity

The standard dip and baked varnish process does not support the growth of fungus. The only concern when units are stored in high humidity areas is retaining the integrity of the insulation material. If units are properly maintained and cleaned at shut down prior to long periods of de-energization there should be no issue with fungus.

Humidity conditions are unimportant as long as the transformer is energized. However, follow the precautionary steps listed below if the transformer is de-energized, is allowed to cool to ambient temperature, and will exceed a shutdown of 12 hours (especially in high humidity conditions).

1. Place small strip heaters in the bottom of the unit shortly after shutdown to maintain the temperature of the unit a few degrees above that of the outside air.
2. Inspect the unit for evidence of moisture before returning it to service.
3. Check the insulation resistance. If evidence of moisture exists, or if the insulation resistance is less than 1 megohm, dry out the transformer by placing it in an oven or by blowing heated air over it.

Enclosure Temperature

The temperature rise on the enclosure exterior for ventilated transformers should not exceed 122°F (50°C), except as indicated in UL 1561.

Prior to Energizing the Transformers

Figure 33: Removing Temporary Braces

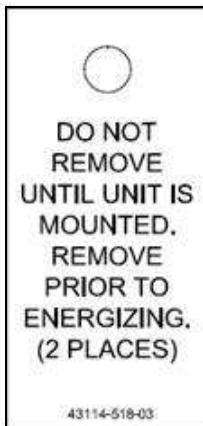

1. Remove any temporary braces. See Figure 33.
2. Check bolted electrical connections. Refer to Making Electrical Connections on page 26 for a detailed check list.
3. Remove excess dirt accumulations from the transformer windings and insulators to permit free circulation of air and to guard against the possibility of insulation breakdowns. Refer to Cleaning on page 38 for a detailed check list.
4. Perform insulation resistance tests with an appropriate device. Refer to Insulation Resistance on page 39 for a detailed instructions.
5. Perform a visual and mechanical check of the transformer and its surrounding environment. Refer to Performing Visual and Mechanical Checks on page 37 for a detailed check list.

Energizing the Transformer

1. Follow all safety precautions and requirements for PPE as outlined in NFPA 70E and any other applicable standards and/or codes.
 - a. Immediately de-energize the transformer if there is any indication of arcing (visual or audible) at any time during the initial start-up.
 - b. Investigate and correct the cause of the arcing before re-energizing the unit.
2. Investigate and correct sources of excessive noise. When energized, the transformer will make some audible noise. Excessive mechanical noise, hums or rattles may be an indication of improperly installed or tightened hardware or enclosure parts.
3. Measure and verify the primary and secondary phase-to-phase and phase-to-ground voltages for all windings.
 - a. Where applicable, measure and verify phase-to-neutral voltages, as well.
 - b. Record and save the values for future reference.

NOTE: Phase-to-phase, phase-to-ground and phase-to-neutral measurements will verify that the transformer is functioning per the nameplate voltages.

- c. Measure phase-to-ground voltages.
- d. Record and save the values for future reference.

NOTE: Phase-to-ground voltages will verify that the unit has been installed correctly.

4. Move one tap at a time, or verify that the jumper lands per the wiring diagram as shown on the nameplate. See Figure 31 on page 28.
NOTE: Do not change taps while the transformer is energized.
 - a. Adjust the transformer taps as necessary to match the actual voltage requirements.
 - b. Ensure taps are cleaned of varnish or other insulating material.
5. Perform a phase rotation check with an appropriate device for loads that are phase sensitive (e.g., certain motor or drive applications).
 - a. Follow the manufacturer's instructions for the device.
 - b. Correct phase rotation errors before energizing the transformer.

Section 6—Maintenance

Performing Visual and Mechanical Checks

⚠ DANGER

HAZARD OF ELECTRIC SHOCK, EXPLOSION, OR ARC FLASH

- Only qualified personnel should clean, inspect maintain and test transformers.
- Turn off power supplying this equipment before working on it.
- Disconnect and electrically isolate power to the transformer so that no accidental contact can be made with energized parts.
- Discharge all static charges held by coils.

Failure to follow these instructions will result in death or serious injury.

1. Perform a visual inspection of the transformer and its surrounding environment.
 - a. Inspect the enclosure for any physical damage.
 - b. Repair any damage, if possible.
 - c. Provide guards to prevent future damage.
2. Record operational data while the transformer is still energized and in service.
3. De-energize the transformer prior to performing work on the unit.
 - a. Follow all safety procedures to place the unit into an electrically safe condition.
 - b. Remove the access covers. Inspect for:
 - dirt on insulating surfaces and at areas which tend to restrict air flow.
 - loose connections.
 - the condition of tap changers or terminal boards.
 - the general condition of the transformer.
4. Inspect the enclosure, transformer, terminals, terminal boards, and insulators for signs of overheating from internal or external sources. Check for voltage creepage over insulating surfaces, evident by tracing or carbonization.
5. Check for evidence of rusting, corrosion and paint deterioration. Repair any rust and corrosion where necessary.

Frequency

The frequency at which transformers should be inspected depends on operating conditions.

For clean, dry locations, annual inspections may be sufficient. However, for other locations, such as where the air is contaminated with dust or chemical fumes, an inspection at three- or six-month intervals may be required. Usually after the first few inspection periods, a definite schedule can be set up based on the transformer's existing conditions.

Severe, Environmental or Special Events

- ❑ Perform routine inspections, maintenance, and testing after any severe electrical short circuit, ground fault, or environmental event (e.g., flooding) to determine the operational status of the transformer.
- ❑ Perform the inspections, maintenance and testing if the transformer has been out of service for an extended period of time. Place strip heaters to maintain the transformer temperature above ambient to prevent condensation from forming in the transformer during extended down time.

Cleaning

Connections and Contact Surfaces

A clean contact surface area is necessary, and terminals must be clean. Where the transformers are installed indoors or outdoors or in a harsh environment, the connections must be sealed with an approved electrical joint compound.

Apply the compound to exposed connections and the surface area before making a bolted connection.

Enclosures, Windings and Insulators

1. De-energize the transformer.
2. Follow the check list below to permit free circulation of air and to guard against insulation breakdowns and thermal performance issues:
 - ❑ Clean the transformer enclosure, windings and insulators by vacuuming or by blowing clean, dry, compressed air or nitrogen. Be sure to wear appropriate personal protective equipment (PPE) when cleaning.
NOTE: Vacuuming is the preferred first step for cleaning. Compressed air should have a dew point of -50°F (-45.5°C) or less, and a pressure at or below 25 psi.
 - ❑ Clean lead supports, tap changers, terminals boards, bushings and other major insulating surfaces with lint-free rags or soft bristle brushes.
NOTE: Do not use liquids, solvents or detergents, as they may deteriorate insulating materials.
 - ❑ Carefully inspect and thoroughly clean the ventilation openings (ducts) and winding assemblies. Remove any blockages.
 - ❑ Remove any trash and/or combustible materials from the area around the unit.

Performing Electrical Testing

⚠ DANGER

HAZARD OF ELECTRIC SHOCK, EXPLOSION, OR ARC FLASH

- Only qualified personnel should clean, inspect maintain and test transformers.
- Turn off power supplying this equipment before working on it.
- Disconnect and electrically isolate power to the transformer so that no accidental contact can be made with energized parts.
- Discharge all static charges held by coils.

Failure to follow these instructions will result in death or serious injury.

Perform the following electrical tests during maintenance:

- ❑ Check all electrical contacts with a calibrated torque wrench.
- ❑ Verify proper spacing.
- ❑ Refer to the manufacturer's specifications for torque values.
- ❑ Check all external hardware for tightness.

Contact Resistance

- ❑ Use a low resistance ohmmeter to measure contact resistance.
 - a. Compare values with similar connections looking for unusually high contact resistance points.
 - b. Investigate any connections that may deviate from common values by more than 50% of the lowest values.
- ❑ An infrared scanning device may be used to look for abnormal temperatures at transformer contacts for energized units.

NOTE: Take care to follow the manufacturer's procedures, as small errors in scanner operation can cause significant errors in detected temperatures.

Insulation Resistance

- Insulation resistance checks may create a capacitive charge on a winding.
1. Ground each winding for at least one minute between tests to drain any static charge created during the test.
 2. Perform insulation resistance tests with an appropriate device.
 3. Test from winding-to-winding and winding-to-ground.
 4. Record all test results for comparison for future readings.
 - Values are installation site dependent and not pre-set at the factory. All testing is compliant to NEMA ST-20.
 - Insulation resistance readings should be at least 1 megohm.
 - Lower readings may indicate the presence of moisture and require a drying procedure to correct.

Winding Resistance

- On larger transformers (>500 kVA):
1. Measure the winding resistances and record for future reference.
 2. Compare the results with the values obtained during the pre-commissioning checks. Readings should not vary by more than 5% with adjacent coils and the pre-commissioning checks.
 3. Record the temperature at which these initial readings were taken.
 - Values are installation site dependent and not pre-set at the factory. All testing is compliant to NEMA ST-20.
 4. Adjust the resistance values based on any differences in temperature between current readings and pre-commissioning values.

Grounding and Bonding

1. Check for proper values of resistance between the system ground lug (or point) and the transformer enclosure, core, frame and clamps.
2. Compare with pre-commissioning values, looking for trends that may indicate a compromise in the quality of the ground bond.

Turns Ratio

1. Perform a turns ratio test on all taps and on the full winding voltages for each phase. Significant changes may indicate a loss of winding continuity.
 - a. Compare these values with those obtained during the pre-commissioning checks. Voltages between phases should not deviate by more than 0.5% from adjacent coils.
 - b. Investigate abnormal readings found outside of this limit.
2. Verify input and output voltages are correct for the tap and output voltages expected. Investigate abnormal readings.

Sound Isolation Pads

Inspect the sound isolation pads for signs of physical deterioration.

Coil Cooling Ducts

1. Inspect all coil cooling ducts for any accumulation of dust, dirt or other obstructions.
2. Follow standard cleaning procedures to ensure proper air flow.

Terminals

Ensure terminals are in good working condition for the proper operation of transformers.

- ❑ Inspect terminals for alignment, tightness (see torque requirements), pressure, burns or corrosion. Investigate and correct any signs of damage.
- ❑ Repair minor pitting, as long as the plating on the terminal has not been compromised.

Section 7—Replacement Parts and Accessories

See Figures 34 and 35 for transformer covers (top, rear and front) and side panels (left and right), and Figure 21 on page 20 and Figure 22 on page 21 for mounting brackets (wall and ceiling). Refer to Table 4 on page 43 for a listing of replacement and accessory parts.

Figure 34: Exploded Assembly for EX75T3H Energy Efficient Transformer with Enclosure Style 20K Front

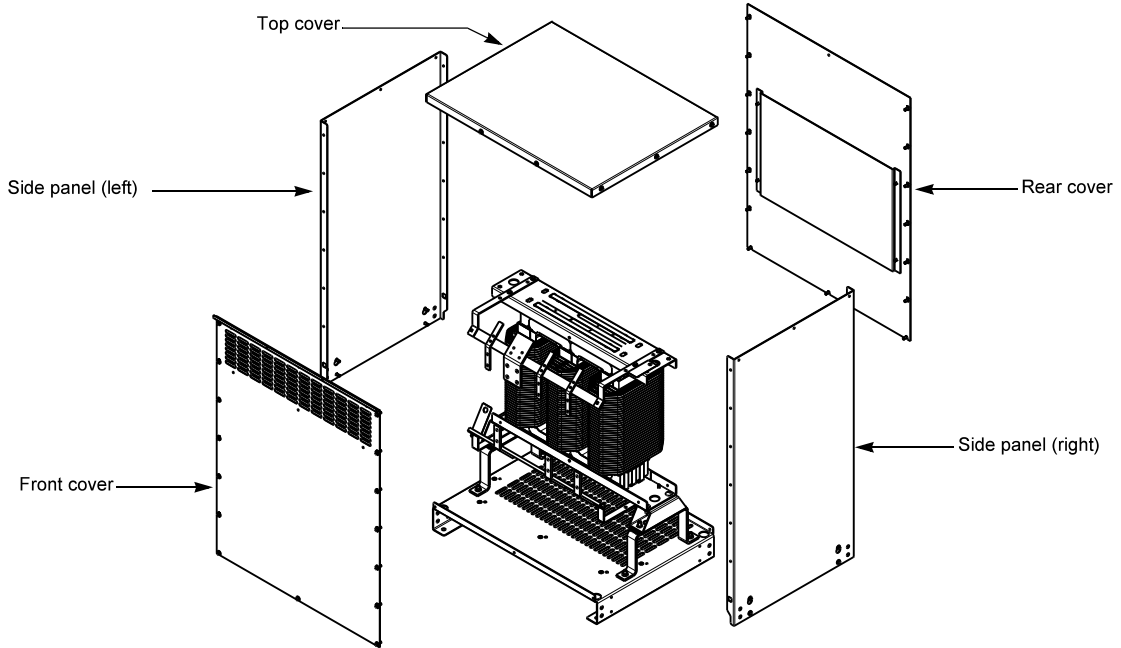
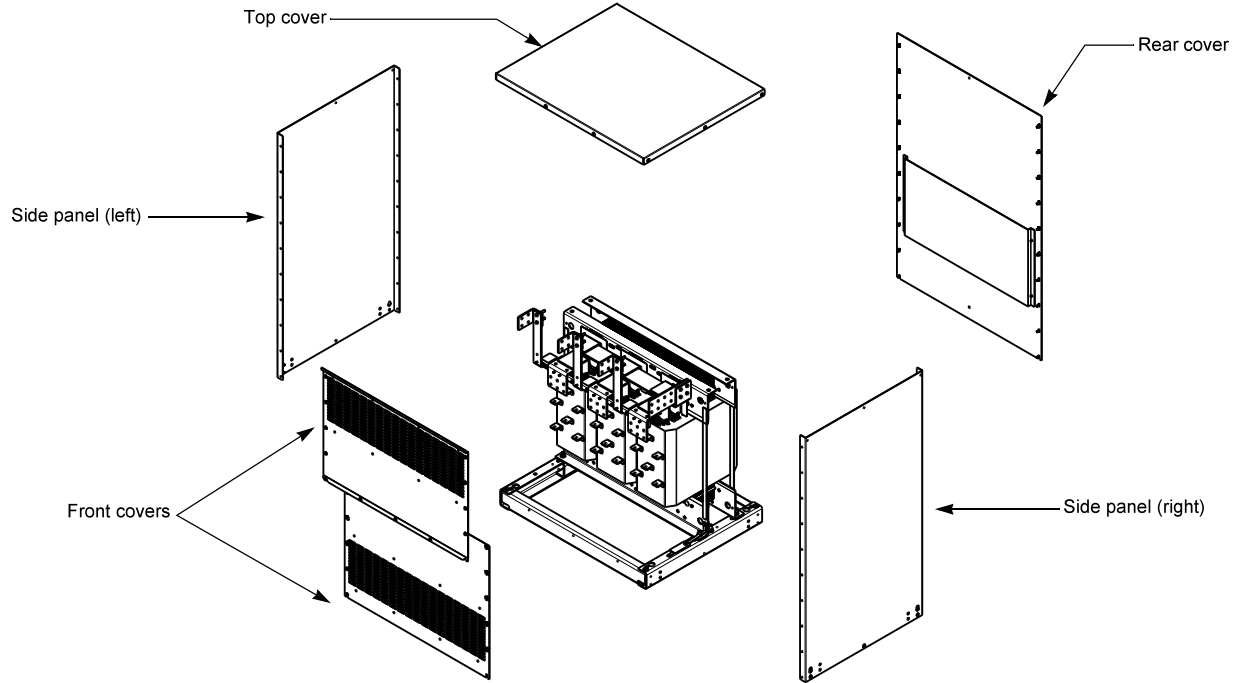

Figure 35: Exploded Assembly for EX300T3H Energy Efficient Transformer with Enclosure Style 25J Front



Refer to the Schneider Electric *Digest*, Section 14, Transformers or call 1-888-Square D (1-888-778-2733) to order replacement parts and accessories.

Refer to Table 4 for enclosure types (top, rear and front covers) side panels, weather-shields and mounting brackets (wall and ceiling).

Table 4: Covers, Side Panels, Weather Shields and Mounting Brackets

Enclosure	Top Cover	Rear Cover	Front Cover	Side Panel (Left and Right)	Weather-shield	Wall Mounting Bracket	Ceiling Mounting Bracket
	Catalog Number						
17D	4310191501	4310191601	4310191601	4310191701	WS363	WMB361362	CMB363
17E	4310191501	—	—	4310191701	—	WMB361362	CMB363
17H	4310191501	4305502003	4305502003	4310191702	WS363	WMB361362	CMB363
17K	7400TC17K	7400R17K	7400FNP17K	7400LR17K	7400WS17K	7400WMB17K	7400CMB17K
18D	4305502101	4305502001	4305502001	4305501001	WS363	WMB363364	CMB363
18E	4305502101	—	—	4305501001	—	WMB363364	CMB363
18H	4305502101	4305502003	4305502003	4310179701	WS363	WMB363364	CMB363
18K	7400TC18K	7400R18K	7400FNP18K	7400LR18K	7400WS18K	7400WMB18K	7400CMB18K
19D	4305501201	4305501101	4305501101	4305501001	WS364	WMB363364	CMB364
19E	—	—	—	—	—	—	—
19K	7400TC19K	7400R19K	7400FNP19K	7400LR19K	7400WS19K	7400WMB19K	7400CMB19K
20D	4305501201	4310192201	4310192201	4310179701	WS364	WMB363364	CMB364
20E	4305501201	—	—	4310179701	—	—	—
20K	7400TC20K	7400R20K	7400FNP20K	7400LR20K	7400WS20K	7400WMB20K	7400CMB20K
21D	4305512501	4300507404	4300507404	4305512601	WS364	—	CMB364
21E	4305512501	—	—	4305512601	—	—	CMB364
21K	7400TC21K	7400R21K	7400FNP21K	7400LR21K	7400WS21K	—	7400CMB21K
22D	4310189001	4310189102	4310189102	4310189201	WS380	—	CMB380
22E	4310189001	—	—	4310189201	—	—	CMB380
22K	7400TC22K	7400R22K	7400FNP22K	7400LR22K	7400WS22K	—	7400CMB22K
23E	—	—	—	—	—	—	—
24D	4310190701	4310190802	4310190802	4310190901	WS381	—	CMB381
24E	4310190701	—	—	4310190901	—	—	CMB381
24K	7400TC24K	7400R24K	7400FNP24K	7400LR24K	7400WS24K	—	7400CMB24K
25D	4310189901	4310190001	4310190001	4310190101	WS382	—	—
25E	4310189901	—	—	4310190101	—	—	—
25J	7400TC25J	7400R25J	7400FNP25J	7400LR25J	7400WS25J	—	—
26D	—	—	—	—	—	—	—
28D	—	—	—	—	—	—	—
28E	—	—	—	—	—	—	—
29D	—	—	—	—	—	—	—
30D	4310192601	(U)4310192901 (L)4310193001	(U)4310192901 (L)4310193001	4310192801	WS383	—	—
30E	4310192601	—	—	—	—	—	—
30J	7400TC30J	7400RU30J 7400RL30J	7400FU30J 7400FLNP30J	7400LR30J	7400WS30J	—	—
31D	—	—	—	—	—	—	—
31E	—	—	—	—	—	—	—
31J	7400TC31J	7400RU31J 7400RL31J	7400FU31J 7400FLNP31J	7400LR31J	7400WS31J	—	—

Touch-up Paint: Catalog Number PK49SP

Refer to Table 5 for available transformer lug kits. For additional information regarding terminal connectors, refer to the label on the reverse side of the transformer front panel. See Figure 36.

Table 5: VERSAtile™ Compression Lugs and Mechanical Set-Screw Types—UL Listed Lugs AL9CU

Transformer kVA Sizes	Kit Catalog Number	Terminal Lugs		Aluminum or Copper Conductor Range (AWG or kcmil)	Hardware Included	
		Qty.	Catalog Number		Qty.	Cap Screws
VERSAtile Compression Equipment Lugs						
15–37 1/2 1Ø	VCELSK1	8	VCEL02114S1	#8–1/0	8	1/4 in. x 1 in.
15–45 3Ø		5	VCEL030516H1	#4–300 kcmil	1	1/4 in. x 2 in.
50–75 1Ø	VCELSK2	13	VCEL030516H1	#4–300 kcmil	8	1/4 in. x 1 in.
75–112 1/2 3Ø					8	1/4 in. x 2 in.
100–167 1Ø	VCELSK3	3	VCEL030516H1	#4–300 kcmil	3	1/4 in. x 3/4 in.
150–300 3Ø		26	VCEL07512H1	#500–750 kcmil Al #500 kcmil Cu	16	3/8 in. x 2 in.
500 3Ø	VCELSK4	34	VCEL07512H1	#500–750 kcmil Al #500 kcmil Cu	21	3/8 in. x 2 in.

NOTE: Refer to UL 486A for torque values to be used with lug connection hardware.

Two nameplates are attached to each unit. See Figure 36. One on the front cover which is required by standards, the second nameplate is attached to the core and coil, providing installation information inside the unit. The second nameplate also carries a UR listing for the core and coil, allowing the enclosure to be removed and the device installed in the equipment.

Figure 36: Sample Nameplates

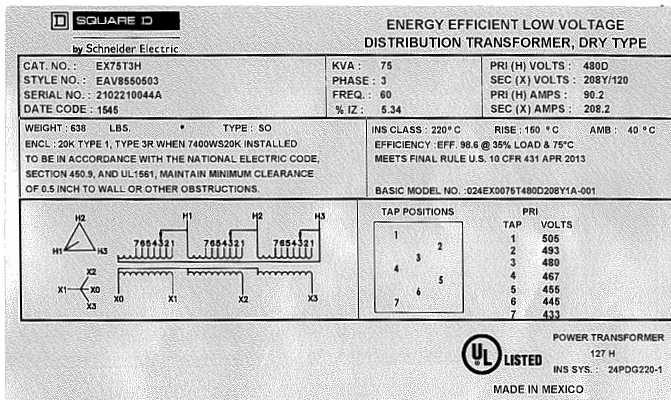

Attached to the Front Cover

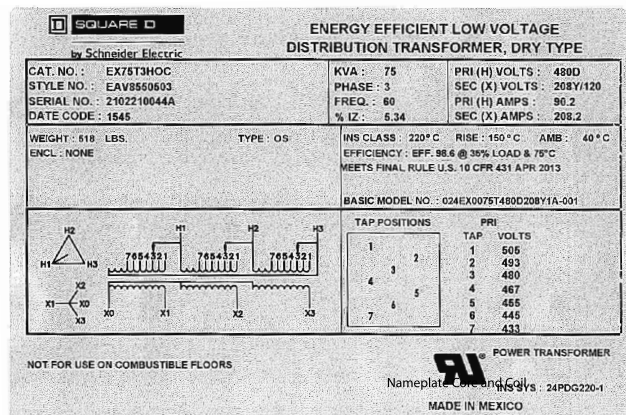

Attached to the Core and Coil

Refer to Table 6 for Square D lug kits for the following dry-type transformers:

- Single-phase primary, single-phase secondary, three-phase Delta primary, three-phase secondary
- Single-phase primary and secondary, three-phase Wye secondary, three-phase Delta with center tap

Table 6: Square D Lug Kits for Dry-type Transformers

Catalog Number	Lugs per Kit	Wire Range	Cap Screws	Current Range	Grounding Lugs per Kit	Wire Range	Bonding Lugs per Kit	Wire Range
Single-phase Primary, Single-phase Secondary, Three-phase Delta Primary, Three-phase Secondary								
DASKP100	3	1/0–14 STR.	1/4 in. x 1 in.	Up to 100 A	Not Applicable	Not Applicable	Not Applicable	Not Applicable
DASKP250	3	350 kcmil–6 STR.	3/8 in. x 2 in.	101–250 A				
DASKP400	3	600 kcmil–4 STR. (2) 250 kcmil–1/0 STR.	3/8 in. x 2 in.	201–400 A				
DASKP600	6	600 kcmil–4 STR. (2) 250 kcmil–1/0 STR.	3/8 in. x 2 in.	601–800 A				
DASKP1000	9	600 kcmil–2 STR.	3/8 in. x 2 in.	601–800 A				
DASKP1200	12	600 kcmil–2 STR.	3/8 in. x 2 in.	801–1200 A				
Single-phase Primary and Secondary, Three-phase Wye Secondary, Three-phase Delta with Center Tap								
DASKGS100	5	1/0–14 STR.	1/4 in. x 1 in.	Up to 100 A	1	(4) 2/0–14 STR.	1	2–14 STR.
DASKGS250	5	350 kcmil–6 STR.	3/8 in. x 2 in.	101–250 A	1	(4) 2/0–14 STR.	1	2–14 STR.
DASKGS400	5	600 kcmil–4 STR. (2) 250 kcmil–1/0 STR.	3/8 in. x 2 in.	201–400 A	1	(4) 2/0–14 STR.	1	1/0–14 STR.
DASKGS600	10	600 kcmil–4 STR. (2) 250 kcmil–1/0 STR.	3/8 in. x 2 in.	601–800 A	1	(4) 350 kcmil–6 STR.	1	250 kcmil–6 STR.
DASKGS1000	15	600 kcmil–2 STR.	3/8 in. x 2 in.	601–800 A	1	(4) 350 kcmil–6 STR.	1	250 kcmil–6 STR.
DASKGS1200	20	600 kcmil–2 STR.	3/8 in. x 2 in.	801–1200 A	1	(4) 350 kcmil–6 STR.	1	250 kcmil–6 STR.
DASKGS2000	25	600 kcmil–2 STR.	3/8 in. x 2 in.	1201–2000 A	1	(4) 350 kcmil–6 STR.	1	250 kcmil–6 STR.

NOTE: Lugs are not supplied with transformer units. They must be purchased separately.
Refer to UL 486A for torque values to be used with lug connection hardware.

Refer to Table 7 for terminal mechanical and compression lugs and their appropriate wire ranges for dry-type transformers.

NOTE: All terminals allow for NEMA two-hole lugs.

Table 7: Terminal Sizes, Mechanical and Compression Lugs and Wire Ranges

kVA	300 Volts and Above		Below 300 Volts	
	Terminal Mechanical Lugs	Terminal Compression Lugs	Terminal Mechanical Lugs	Terminal Compression Lugs
15	2/0–14 AWG	(1) #12–10 AWG (1) #8–#1/0 AWG	2/0–14 AWG	(1) #8–#1/0 AWG
30	2/0–14 AWG	(1) #8–#1/0 AWG	350 kcmil–6 AWG	(1) #8–#1/0 AWG (1) #4–300 kcmil (1) 250–350 kcmil
45	2/0–14 AWG 350 kcmil–6 AWG	(1) #8–#1/0 AWG (1) #4–300 kcmil	350 kcmil–6 AWG (1) 600 kcmil–4 AWG or (2) Equal 250 kcmil–1/0 AWG	(1) 250–350kcmil (1) #2/0–500 kcmil (2) #4–300 kcmil
75	2/0–14 AWG 350 kcmil–6 AWG	(1) #8–#1/0 AWG (1) #4–300 kcmil (1) 250–350 kcmil	(1) 600 kcmil–4 AWG or (2) Equal 250 kcmil–1/0 AWG	(2) #2/0–500 kcmil (1) 400–600 kcmil AI (2) #4–300 kcmil (2) 250–350 kcmil
112.5	350 kcmil–6 AWG (1) 600 kcmil–4 AWG or (2) Equal 250 kcmil–1/0 AWG	(1) 250 kcmil–350 kcmil (1) #2/0–500 kcmil (2) #4–300 kcmil	(2) 350 kcmil–6 AWG (2) 600 kcmil–2 AWG	(3) 250–350 kcmil (3) #4–300 kcmil (2) 400–600 kcmil AI
150	(1) 600 kcmil–4 AWG or (2) Equal 250 kcmil–1/0 AWG	(1) 250–350 kcmil (2) #4–300 kcmil	(3) 350 kcmil–6 AWG (2) 600 kcmil–2 AWG	(3) #2/0–500 kcmil (3) #4–300 kcmil (3) 400–600 kcmil AI (4) 250–350 kcmil
225	1) 600 kcmil–2 AWG (2) 600 kcmil–2 AWG	(2) #2/0–500 kcmil (2) 400–600 kcmil AI (2) #4–300 kcmil	(3) 600 kcmil–2 AWG	(4) #4–300 kcmil (4) #2/0–500 kcmil
300	(2) 600 kcmil–2 AWG	(3) 250–350 kcmil (3) #2/0–500 kcmil (3) 400–600 kcmil AI	(4) 600 kcmil–2 AWG	(6) #2/0–500 kcmil (6) 400–600 kcmil AI
500	(3) 600 kcmil–2 AWG	(4) #4–300 kcmil (4) #2/0–500 kcmil	(6) 600 kcmil–2 AWG	(9) #2/0–500kcmil (9) 400–600 kcmil AI
750	(4) 600 kcmil–2 AWG	(6) #2/0–500 kcmil (6) 400–600 kcmil AI	(9) 600 kcmil–2 AWG	(15) #2/0–500 kcmil (15) 400–600 kcmil AI

NOTE: All terminals allow for NEMA two-hole lugs.

Refer to Table 8 for Square D ground bar kits.

Table 8: Square D Ground Bar Kits

Catalog Number	Grounding Lugs per Kit	Wire Range
DASKGTB100400	1	(4) 2/0–14 STR.
DASKGTB6002000	1	(4) 350 KCMIL–6 STR.

**Dry-type Transformers—1000 Volts and Below
Instruction Bulletin**

ENGLISH

Schneider Electric
800 Federal Street
Andover, MA 01810 USA
1-888-778-2733
www.schneider-electric.us

Electrical equipment should be installed, operated, serviced, and maintained only by qualified personnel. No responsibility is assumed by Schneider Electric for any consequences arising out of the use of this material.

© 1992–2015 Schneider Electric All Rights Reserved
Schneider Electric and Square D are trademarks owned by Schneider Electric Industries SAS or its affiliated companies. All other trademarks are the property of their respective owners.

43006-850-01 Rev. 02, 11/2015
Replaces 43006-850-01 Rev 01, 12/1992