

# PowerPact™ H-, J-, and L-Frame Circuit Breakers

## Accessories for Micrologic™ Trip Units

### Circuit Breaker Communication Network Options

All PowerPact H-, J-, and L-frame circuit breakers devices can be equipped with the communication function using a pre-wired connection system and a Modbus™ communication interface module. The interface module can be connected directly or through the front display module (FDM121).

The PowerPact H-, J-, and L-frame circuit breakers can be integrated in a Modbus communication network. Four functional levels can be used separately or combined to adapt to all supervision requirements.

Level	Function
Communication of status indications	<p>Compatible with PowerPact H-, J- and L-frame circuit breakers and automatic switches. Use the BSCM module to access the following information:</p> <ul style="list-style-type: none"> <li>• ON/OFF position</li> <li>• trip indication</li> <li>• fault-trip indication</li> </ul>
Communication of commands	<p>Available on all circuit breakers and automatic switches with communicating motor operators, the remote control can be used to:</p> <ul style="list-style-type: none"> <li>• open</li> <li>• closed</li> <li>• reset</li> </ul>
Communication of measurements with Micrologic 5 / 6 A or E trip unit	<p>This level provides access to:</p> <ul style="list-style-type: none"> <li>• instantaneous and demand values</li> <li>• maximums/minimums</li> <li>• energy metering</li> <li>• demand current and power</li> <li>• power quality</li> </ul>
Communication of operating assistance with Micrologic 5 / 6 A or E trip unit	<p>This level also provides access to:</p> <ul style="list-style-type: none"> <li>• protection and alarm settings</li> <li>• time-stamped histories and event tables</li> <li>• maintenance indicators</li> </ul>

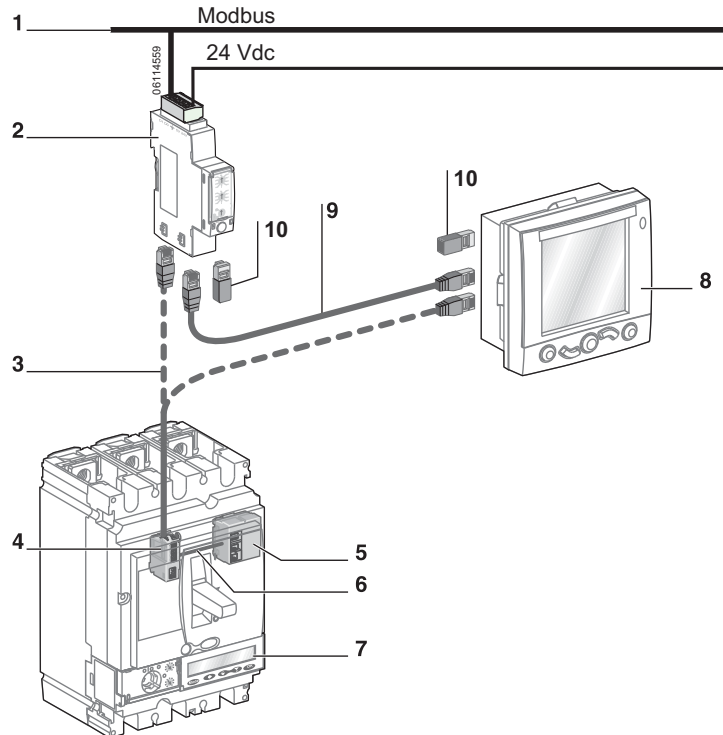

PowerPact H-, J-, or L-frame circuit breaker is connected to the Modbus communication interface module (IFM) or front display module (FDM121) through the internal terminal block for the NSX cord.

The front display module is connected to the Modbus communication interface module by a communication cable with RJ45 connectors on both ends.

1. Modbus network
2. Modbus communication interface module
3. NSX cord
4. Internal terminal block for communication using the NSX cord
5. BSCM module
6. Prefabricated wiring
7. Micrologic trip unit
8. FDM121 display
9. RJ45 cable
10. Line terminator (for unused connectors, if applicable)

## Circuit Breaker Communication Networks and Software

### Modbus™ Communication Network

Modbus is the most widely used communication protocol in industrial networks. It operates in master-slave mode. The devices (slaves) communicate one after the other with a gateway (master).

Masterpact™ and PowerPact™ circuit breakers with Micrologic trip units, PowerLogic™ and Sepam™ products all operate with this protocol. A Modbus network is generally implemented on an LV or MV system. Micrologic trip units use the Modbus communication protocol, compatible with ION-Enterprise PowerLogic supervision systems.

Depending on the data monitored and the desired refresh rate, a Modbus network connected to a gateway can serve 4 to 16 devices. For larger installations, a number of Modbus networks can be connected to an Ethernet® network (TCP/IP/Modbus protocol) through their gateways.

The downloadable RSUsoftware application facilitates implementation of communication network functions.

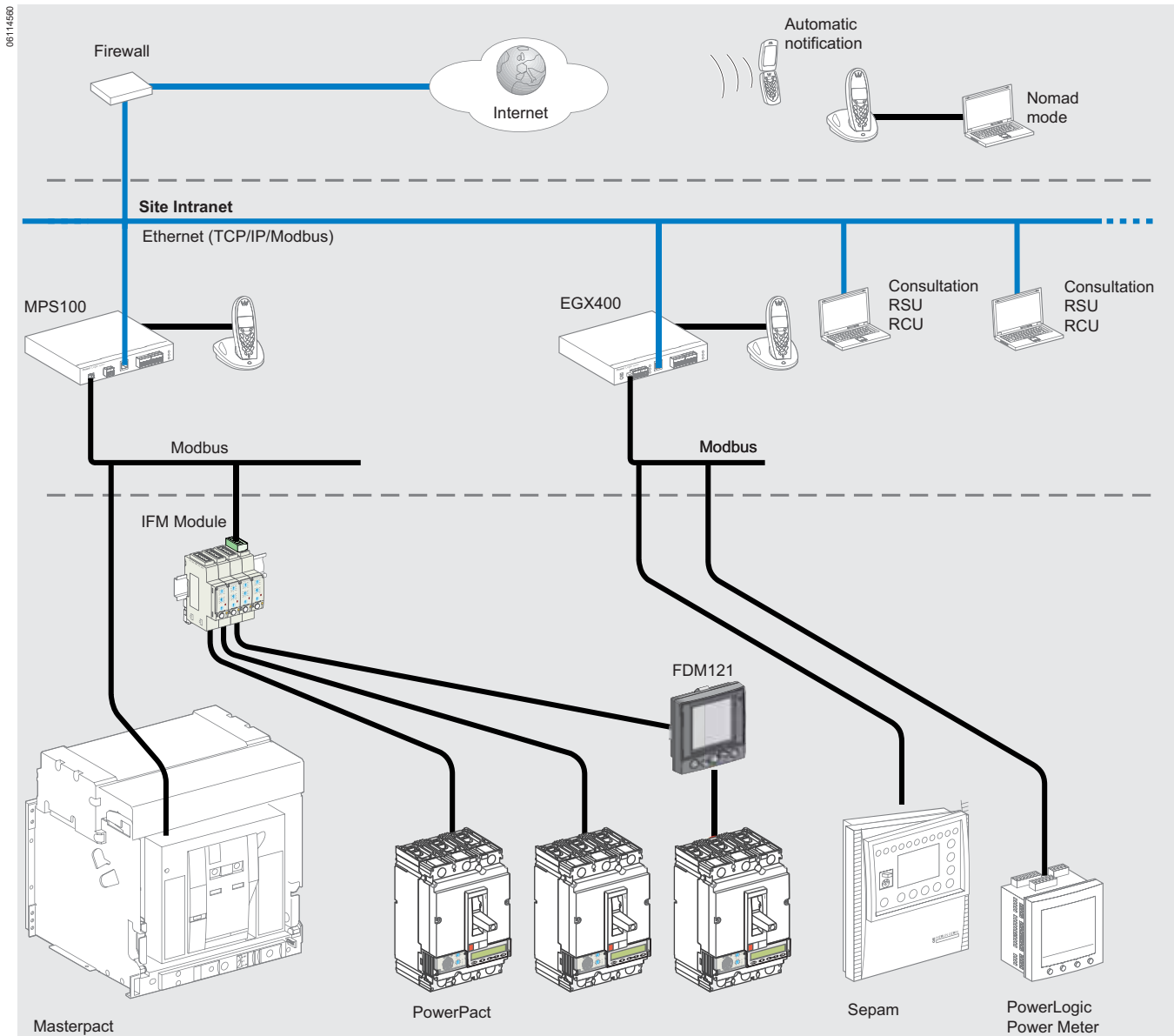

# PowerPact™ H-, J-, and L-Frame Circuit Breakers

## Installation Recommendations

### Wiring

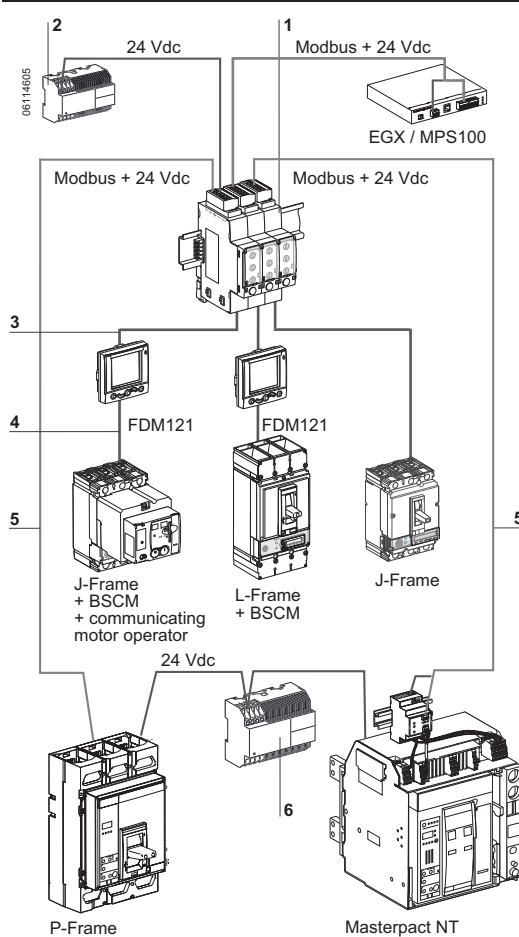

- 1 Modbus interface module with connection accessory.
- 2 24 Vdc power supply of Micrologic for Powerpact H-, J-, and L-Frame communication modules.
- 3 ULP cord.
- 4 NSX cord.
- 5 Modbus cable + 24 Vdc part no. 50965 (Schneider Electric) recommended or part no. 7895A (Belden).
- 6 24 Vdc power supply of Micrologic for PowerPact M-Frame/ Masterpact circuit breakers.

#### Micrologic 5 or 6 Without the Communication Function

The external 24 Vdc supply is connected through the circuit breaker terminal block.

Use of a 24 Vdc battery provides backup power for approximate 3 hours (100 mA) in the event of an interruption in the external supply.

#### Micrologic 5 or 6 With the Communication Function

The external 24 Vdc supply is connected through the Modbus interface using a five-pin connector, including two for the power supply. Stacking accessories (see page 81) can be used to supply a number of interfaces by fast clip-on connection.

The 24 Vdc power is distributed downstream by the ULP (Universal Logic Plug) communication cables with RJ45 connectors. This system ensures both data transfer and power distribution to the connected modules.

#### Recommendations for 24 Vdc Wiring

Do not connect the positive terminal to ground

- Do not connect the negative terminal to ground.
- The maximum length for each conductor (+/-) is 33 ft (10 m).
- For connection distances greater than ten metres, the plus and minus conductors of the 24 Vdc supply must be twisted to improve EMC.
- The 24 Vdc conductors must cross the power cables perpendicularly. If this is difficult or impossible, the plus and minus conductors must be twisted.