

PowerPact™ M-, P- and R-Frame, and Compact™ NS630b–NS3200 Circuit Breakers

Section 5—PowerPact P-Frame Molded Case Circuit Breakers

Figure 7: Accessory Control Wiring Diagrams for Manually-Operated Circuit Breakers

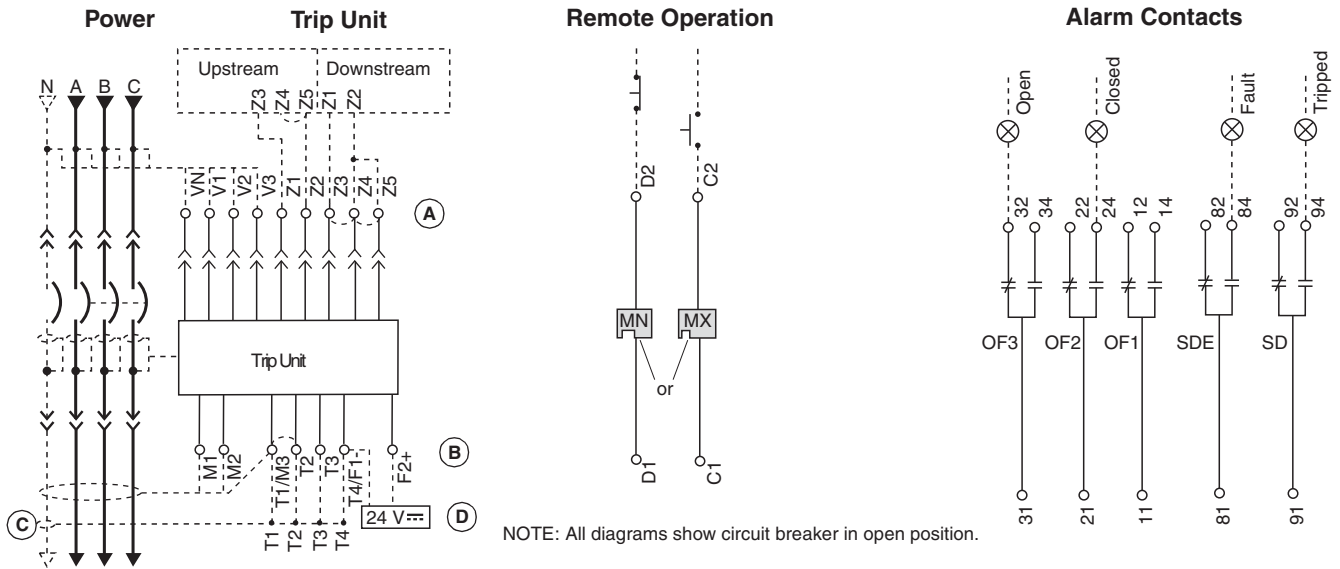

- A—Do not remove factory-installed jumpers between Z3, Z4 and Z5 unless ZSI is connected.
- B—Do not remove factory-installed jumper between T1 and T2 unless neutral CT is connected. Do not install jumper between T3 and T4.
- C—For proper wiring of neutral CT, refer to Instruction Bulletin 48041-082-01 shipped with it.
- D—24 Vdc power supply for trip unit must be separate and isolated from 24 Vdc power supply for communication modules.

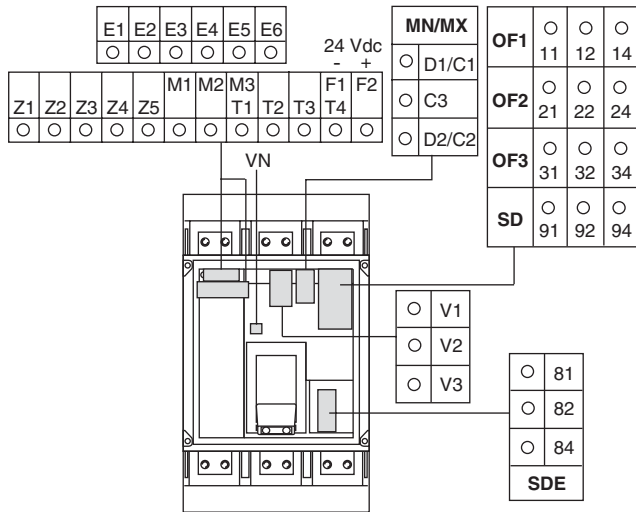

Connector	Recommended Wire Size
V1, V2, V3, Vn	22–16 AWG (0.3–1.5 mm ²)
E1–E2	22 AWG (0.3 mm ²) MIN shielded pair cable or twisted pair copper wires
T	22 AWG (0.3 mm ²) stranded shielded cable
M	Refer to MDGF instructions
E3–E6, Q1, Q2, Q3	22 AWG (0.3 mm ²) shielded twisted pairs with drain (Belden 8723 or equal) ³
OF, SD, SDE	18–16 AWG (0.8–1.5 mm ²)
MN, MX	18–14 AWG (0.8–2.5 mm ²)
F	Size per aux 24 Vdc power supply
Z1–Z5	22–18 AWG (0.3–0.8 mm ²)

Trip Unit Type	Basic				Connector	Description
	A	P	H			
—	•	•	•	Com: E1-E6	Circuit breaker communication module E1 = +24 Vdc E2 = Common E3 = A/Tx- D0 E4 = B/Tx+ D1 E5 = A/Rx- D0 E6 = B/Rx+ D1	
—	•	•	•	Z	Zone-selective interlocking (ZSI) Z1 = ZSI OUT signal Z2 = ZSI OUT Z3 = ZSI IN signal Z4 = ZSI IN short-time delay Z5 = ZSI IN ground fault	
—	•	•	•	T	External neutral sensor	
—	•	•	•	F	24 Vdc external power supply	
—	—	•	•	Vn ¹	External neutral voltage takeoff	
—	—	•	•	V1, V2, V3	External phase voltage takeoff	
—	—	•	•	M6C ² : Q1, Q2, Q3	6 programmable contacts 24 Vdc external power supply required	
Function	Connector				Description	
Auxiliary Contacts	OF				Open/Closed circuit breaker or switch position contacts	
	SD				Bell alarm	
	SDE				Electrical fault alarm contact	
Remote Operation	MN				Undervoltage trip device	
	MX				Shunt trip	

¹ Neutral voltage supplied with flying leads.
² Optional M6C programmable contacts are supplied with flying leads.

PowerPact™ M-, P- and R-Frame, and Compact™ NS630b–NS3200 Circuit Breakers

Section 5—PowerPact P-Frame Molded Case Circuit Breakers

Figure 8: Accessory Control Wiring Diagrams for Electrically-operated Circuit Breakers

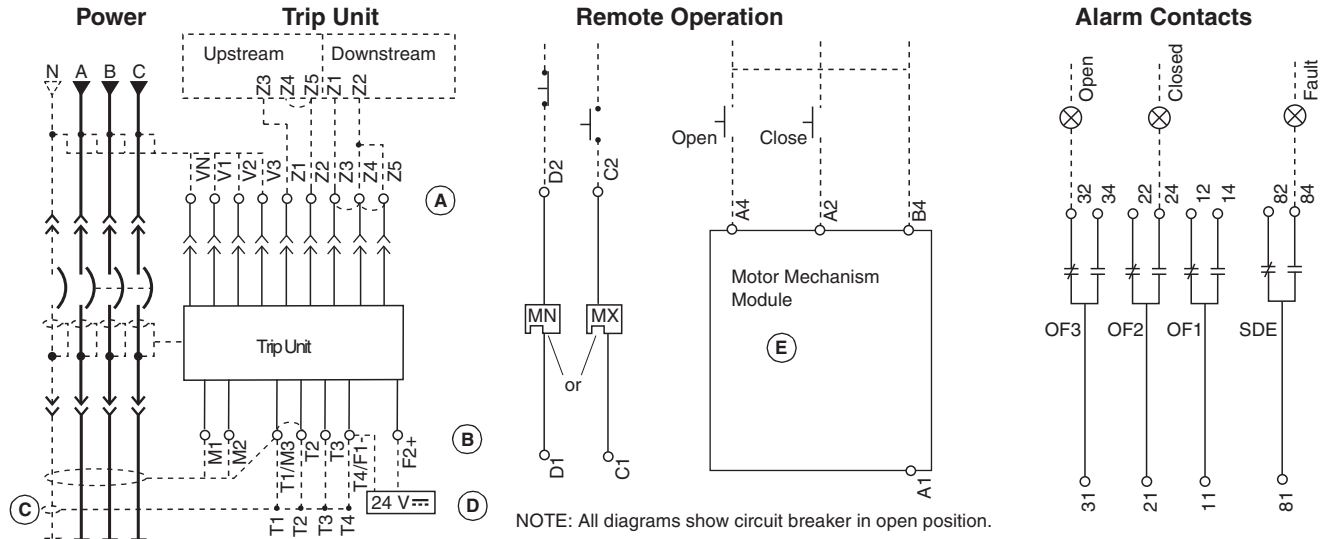

NOTE: All diagrams show circuit breaker in open position.

- A—Do not remove factory-installed jumpers between Z3, Z4 and Z5 unless ZSI is connected.
- B—Do not remove factory-installed jumper between T1 and T2 unless neutral CT is connected. Do not install jumper between T3 and T4.
- C—For proper wiring of neutral CT, refer to Instruction Bulletin 48041-082-01 shipped with it.
- D—24 Vdc power supply for trip unit must be separate and isolated from 24 Vdc power supply for communication modules.
- E—Motor mechanism includes opening and closing coils.

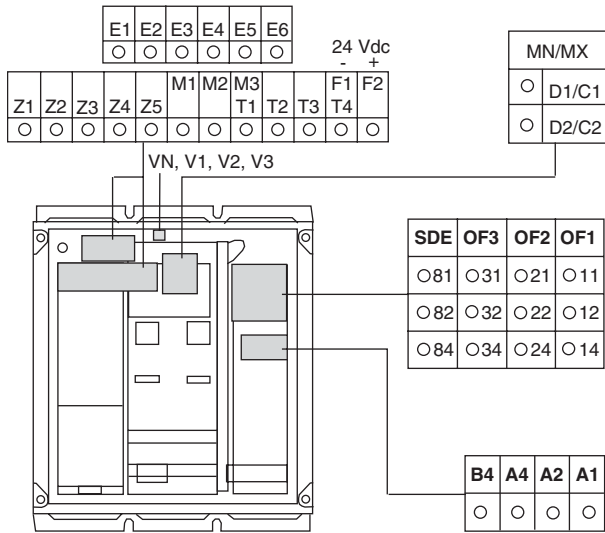

Trip Unit Type				Connector	Description
Basic	A	P	H		
—	•	•	•	Com: E1-E6	Circuit breaker communication module E1 = +24 Vdc E2 = Common E3 = A/Tx- D0 E4 = B/Tx+ D1 E5 = A/Rx- D0 E6 = B/Rx+ D1
—	•	•	•	Z	Zone-selective interlocking (ZSI) Z1 = ZSI OUT signal Z2 = ZSI OUT Z3 = ZSI IN signal Z4 = ZSI IN short-time delay Z5 = ZSI IN ground fault
—	•	•	•	T	External neutral sensor
—	•	•	•	F	24 Vdc external power supply
—	—	•	•	Vn ¹	External voltage takeoff
—	—	•	•	V1, V2, V3 ¹	External phase voltage takeoff
—	—	•	•	M6C ¹ : Q1, Q2, Q3	6 programmable contacts 24 Vdc external power supply required
Function		Connector	Description		
Auxiliary Contacts		OF	Open/Closed circuit breaker or switch position contacts		
		SDE	Electrical fault alarm contact		
Remote Operation		MN	Undervoltage trip device		
		MX	Shunt trip		
Motor Mech Module		A4	Electrical opening		
		A2	Electrical closing		
		B4, A1	Power supply for control devices and gear motor		

Connector	Recommended Wire Size
E1–E2	22 AWG (0.3 mm ²) MIN shielded pair cable or twisted pair copper wires
V1, V2, V3, Vn	22–16 AWG (0.3–1.5 mm ²)
T	22 AWG (0.3 mm ²) stranded shielded cable
E3–E6, Q1, Q2, Q3	22 AWG (0.3 mm ²) shielded twisted pairs with drain (Belden 8723 or equal) ³
M	Refer to MDGF instructions
OF, SD, SDE	18–16 AWG (0.8–1.5 mm ²)
MN, MX	18–14 AWG (0.8–2.5 mm ²)
F	Size per aux 24 Vdc power supply
Z1–Z5	22–18 AWG (0.3–0.8 mm ²)

¹ Optional M6C and external voltage takeoff are supplied with flying leads.