

Section 11—Wiring Diagrams

Unit-Mount Circuit Breakers

Power	Micrologic Trip Unit <sup>1</sup>	Remote Operation
-------	-----------------------------------	------------------

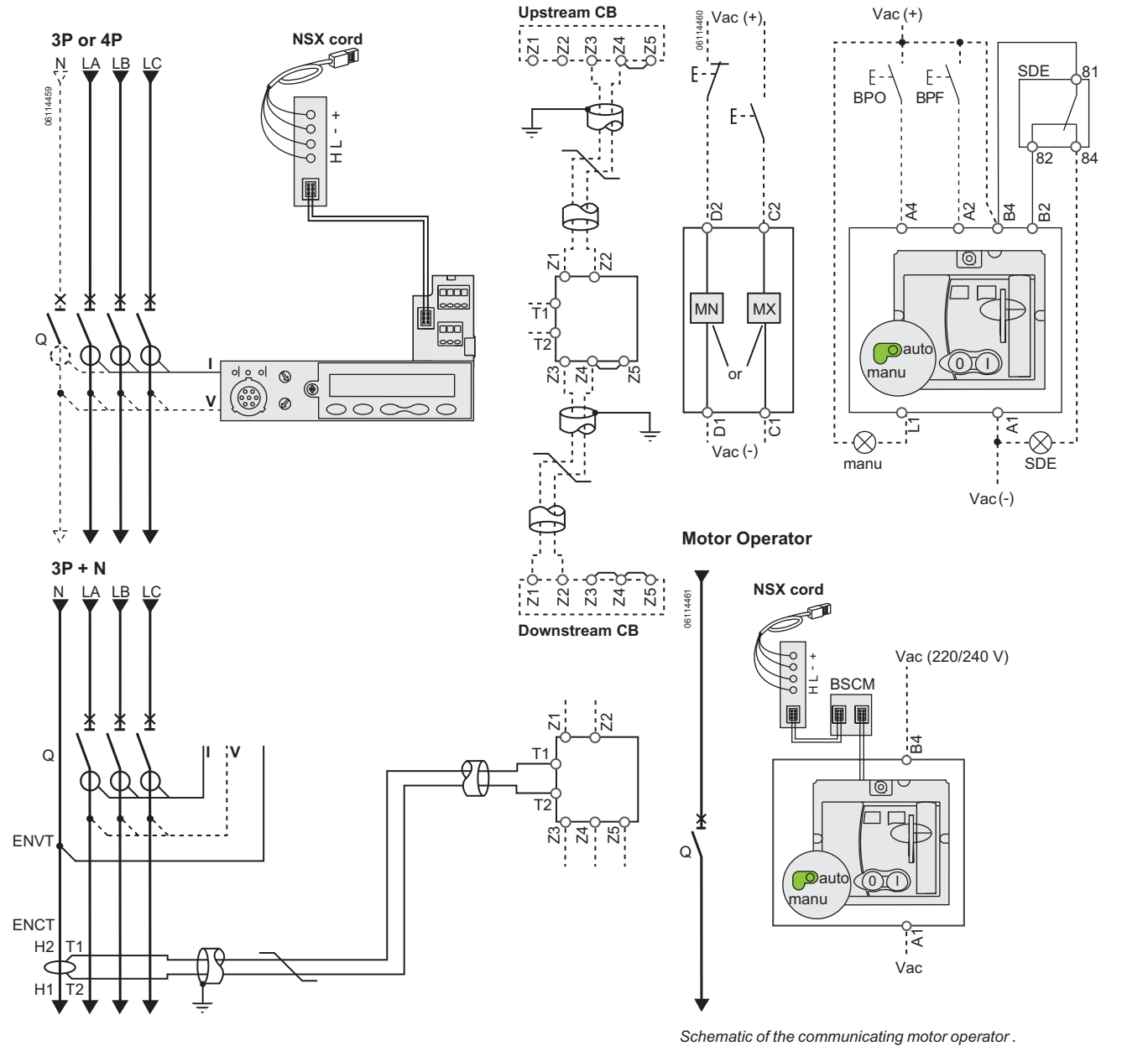

Schematic of the communicating motor operator.

Communicating Motor Operator

Continued on next page

## Unit-Mount Circuit Breakers *(continued)*

### Indication Contacts

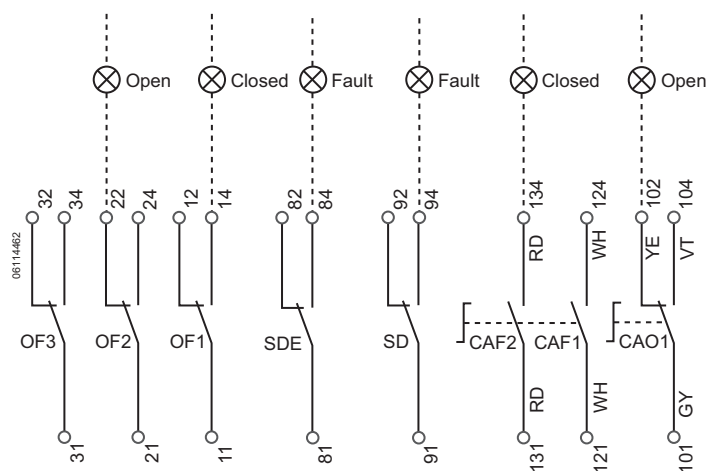

The diagram is shown with circuits de-energized, relays in normal position, and all devices open, connected, and charged. Terminal connections shown as O must be connected by the customer.

### Micrologic Trip Unit A or E

	Communication
<b>A/E</b>	H (WH), L(BL): data -(BK), +(RD): 24 Vdc power supply
<b>ZSI (Zone Selective Interlocking)</b>	
	Z1: ZSI OUT SOURCE
	Z2: ZSI OUT
<b>A/E</b>	Z3: ZSI IN SOURCE
	Z4: ZSI IN ST (short time)
	Z5: ZSI IN GF (ground fault)
	(Z3, Z4, and Z5 for L-frame circuit breaker only)
<b>A/E</b>	ENCT: External Neutral Current Transformer: -Shielded cable with 1 twisted pair (T1, T2) -Shielding earthed at CT end only Connection L = 12 in. (30 cm) max. -Maximum length of 33 ft (10 m) -Cable size of 22 AWG -Recommended cable: Belden 9451SB or equivalent
<b>E</b>	ENVT: External Neutral Voltage Tap for Connection to the Neutral using a 3P Circuit Breaker

### Color Code for Auxiliary Wiring

RD: Red	VI: Violet
WH: White	GY: Gray
YE: Yellow	OR: Orange
BK: Black	BL: Blue
GN: Green	

### Remote Operation

**MN** Undervoltage Release

or

**MX** Shunt Release

### Motor Operator

**A4** Opening Order

**A2** Closing Order

**B4, A1** Power Supply to Motor Operator

**L1** Manual Position (manu)

**B2** Overcurrent Trip Switch Interlocking (mandatory for correct operation)

**BPO** Opening Pushbutton

**BPF** Closing Pushbutton

### Communicating Motor Operator

**B4, A1** Motor Operator Power Supply

**BSCM** Breaker Status and Control Module

### Indication Contacts

**OF2/OF1** Device ON/OFF Auxiliary Switches

**OF3** Device ON/OFF Auxiliary Switches (L-Frame)

**SDE** Overcurrent Trip Switch (short-circuit, overload, ground fault, earth leakage)

**SD** Alarm Switch

**CAF2/CAF1** Early-Make Contact (rotary handle only)

**CAO1** Early-Break Contact (rotary handle only)

# PowerPact™ H-, J-, and L-Frame Circuit Breakers Wiring Diagrams

## Plug-In and Drawout Circuit Breakers

Power	Micrologic Trip Unit <sup>1</sup>	Remote Operation
-------	-----------------------------------	------------------

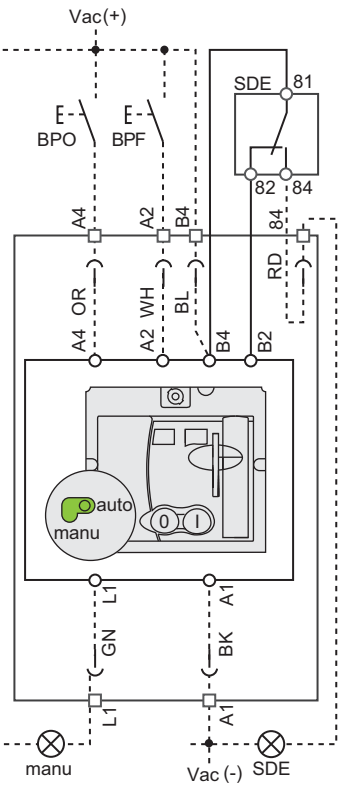
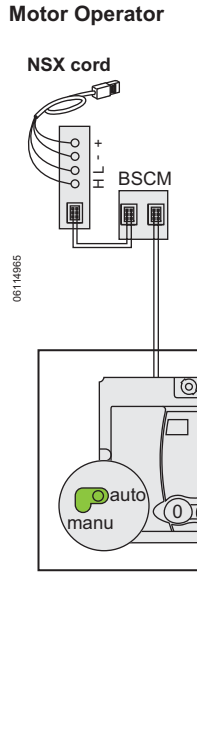
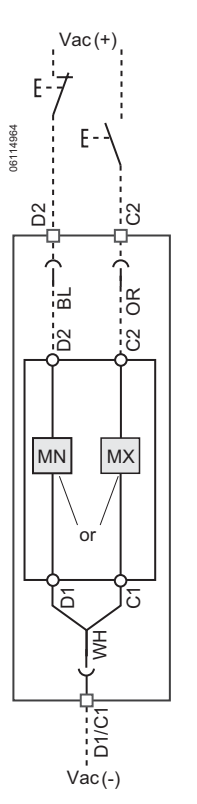
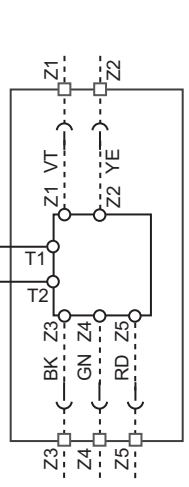
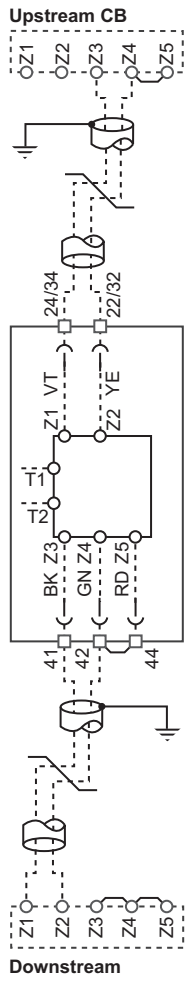
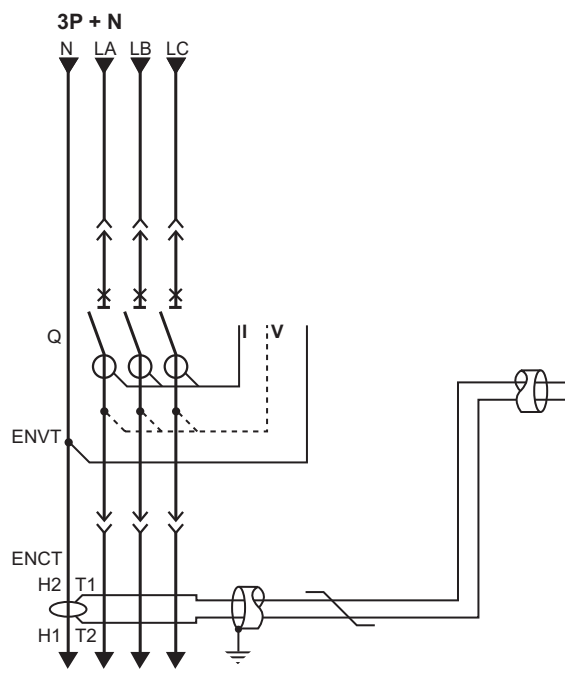
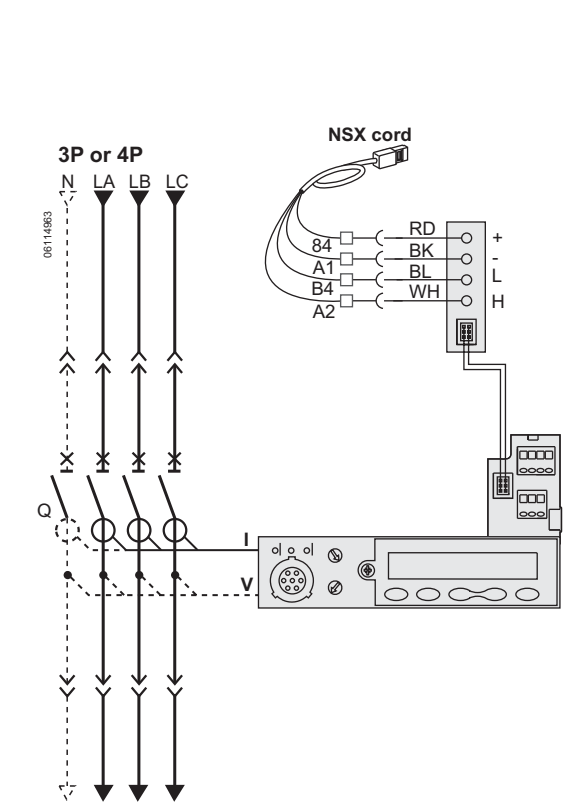

# PowerPact™ H-, J-, and L-Frame Circuit Breakers Wiring Diagrams

## Plug-In and Drawout Circuit Breakers (continued)

### Indication Contacts

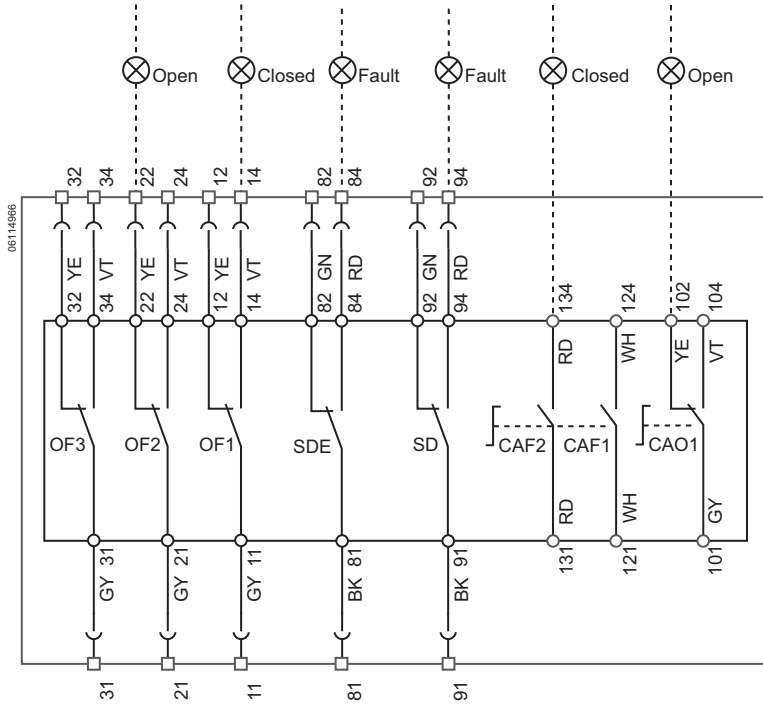

### Carriage Switches

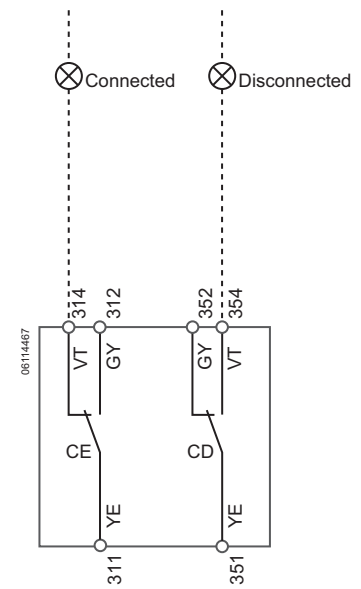

The diagram is shown with circuits de-energized, relays in normal position, and all devices open, connected, and charged.

Terminal connections shown as □ and O must be connected by the customer.

### Micrologic Trip Unit A or E

	Communication
<b>A/E</b>	H (WH), L(BL): data -(BK), +(RD): 24 Vdc power supply
	ZSI (Zone Selective Interlocking)
	Z1: ZSI OUT SOURCE Z2: ZSI OUT
<b>A/E</b>	Z3: ZSI IN SOURCE Z4: ZSI IN ST (short time) Z5: ZSI IN GF (ground fault) (Z3, Z4, and Z5 for L-frame circuit breaker only)
<b>A/E</b>	ENCT: External Neutral Current Transformer: -Shielded cable with 1 twisted pair (T1, T2) -Shielding earthed at CT end only Connection L = 12 in. (30 cm) max. -Maximum length of 33 ft (10 m) -Cable size of 22 AWG -Recommended cable: Belden 9451SB or equivalent
<b>E</b>	ENVV: External Neutral Voltage Tap for Connection to the Neutral using a 3P Circuit Breaker

### Color Code for Auxiliary Wiring

RD: Red	VI: Violet
WH: White	GY: Gray
YE: Yellow	OR: Orange
BK: Black	BL: Blue
GN: Green	

### Remote Operation

<b>MN</b>	Undervoltage Release
or	
<b>MX</b>	Shunt Release

### Motor Operator

<b>A4</b>	Opening Order
<b>A2</b>	Closing Order
<b>B4, A1</b>	Power Supply to Motor Operator
<b>L1</b>	Manual Position (manu)
<b>B2</b>	Overcurrent Trip Switch Interlocking (mandatory for correct operation)
<b>BPO</b>	Opening Pushbutton
<b>BP</b>	Closing Pushbutton

### Communicating Motor Operator

<b>B4, A1</b>	Motor Operator Power Supply
<b>BSCM</b>	Breaker Status and Control Module

### Indication Contacts

<b>OF2/OF1</b>	Device ON/OFF Auxiliary Switches
<b>OF3</b>	Device ON/OFF Auxiliary Switches (L-Frame)
<b>SDE</b>	Overcurrent Trip Switch (short-circuit, overload, ground fault, earth leakage)
<b>SD</b>	Alarm Switch
<b>CAF2/CAF1</b>	Early-Make Contact (rotary handle only)
<b>CAO1</b>	Early-Break Contact (rotary handle only)

# PowerPact™ H-, J-, and L-Frame Circuit Breakers

## Wiring Diagrams

### Motor Operator

**NOTE:** The diagram is shown with circuits de-energized, relays in normal position, and all devices open, connected, and charged.

After tripping initiated by the “Push to trip” button, the undervoltage release (MN), or the shunt release (MX), device can be reset automatically, remotely, or manually.

Following tripping due to an electrical fault, reset must be carried out manually.

**Motor Operator with Automatic Reset**

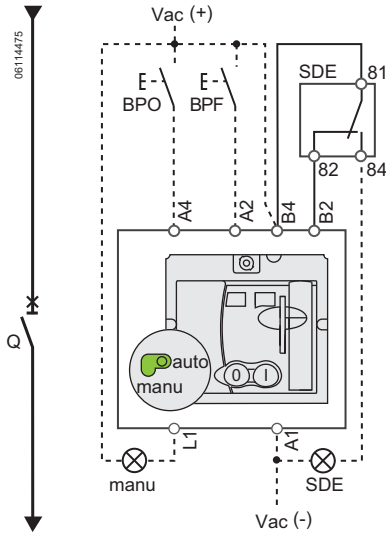

**Motor Operator with Remote Reset**

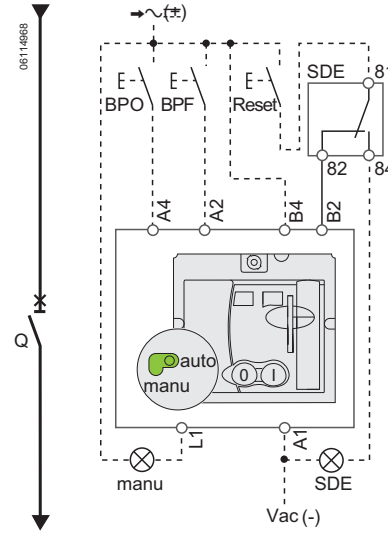

#### Symbols

- Q: Circuit Breaker
- A4: Opening Order
- A2: Closing Order
- B4, A1: Motor Operator Power Supply
- L1: Manual Position (manu)
- B2: Overcurrent Trip Switch Interlocking (mandatory for correct operation)
- BPO: Opening Pushbutton
- BPF: Closing Pushbutton
- SDE: Fault-Trip Indication Contact (short-circuit, overload, ground fault, earth leakage)

**Motor Operator with Manual Reset**

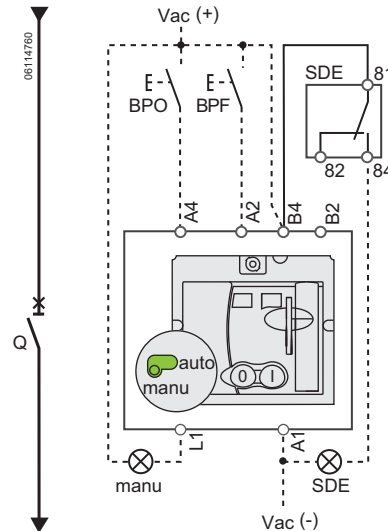

# PowerPact™ H-, J-, and L-Frame Circuit Breakers Wiring Diagrams

## Motor Operator *(continued)*

### Symbols

- Q:** Circuit Breaker
- B4, A1:** Motor Operator Power Supply
- BSCM:** Breaker Status and Control Module

### Communicating Motor Operator

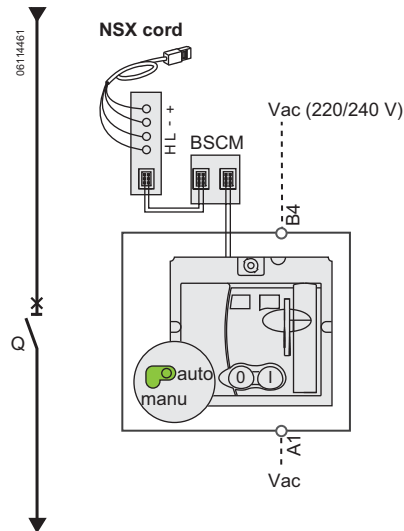

Schematic of the communicating motor operator.

### RSU Screen for Communicating Motor Operator

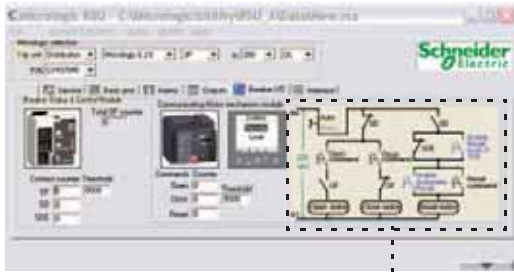

RSU utility setup screen for the communicating motor operator

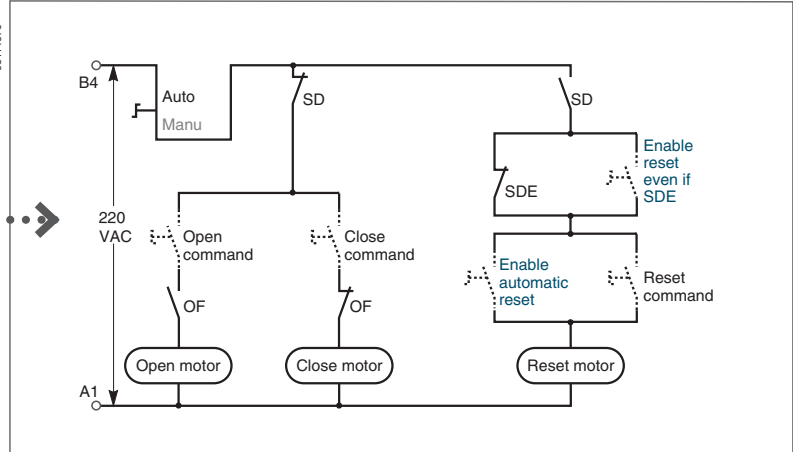

Single-line diagram of communicating motor operator

Opening, closing and reset orders are transmitted through the communication network. The "Enable automatic reset" and "Enable reset even if SDE" parameters must be set using the RSU software using the screen by clicking the blue text.

"Auto/Manu" is a switch on the front of the motor operator.

Terminal connections shown as O must be connected by the customer.

# PowerPact™ H-, J-, and L-Frame Circuit Breakers

## Wiring Diagrams

### SDx Module with Micrologic™ Trip Unit

**NOTE:** The diagram is shown with circuits de-energized, relays in normal position, and all devices open, connected, and charged.

#### Symbols

- SD1, SD3:** SDx Module Power Supply
- SD2:** Output 1 (80 mA max.)
- SD4:** Output 2 (80 mA max.)

	SD2	SD4
<b>Micrologic 3</b>	SdT	—
<b>Micrologic 5</b>	SdT or Output 1	PAL I <sub>r</sub> or Output 2
<b>Micrologic 6</b>	SdT or Output 1	SDG or Output 2

Terminal connections shown as O must be connected by the customer.

#### Connection

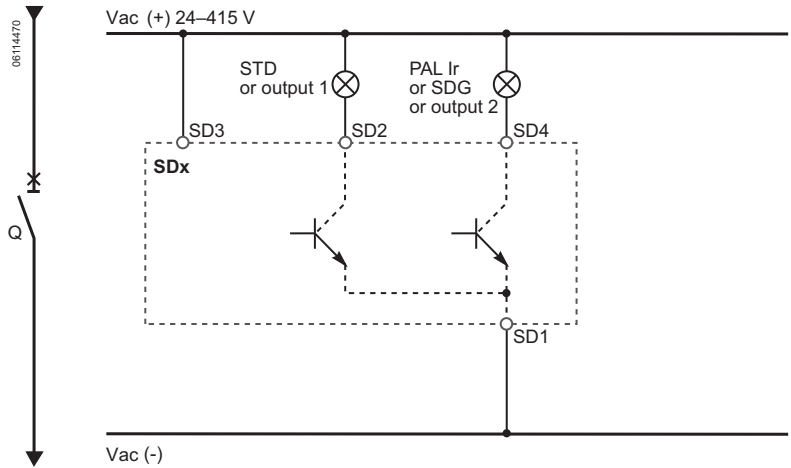

#### Operation

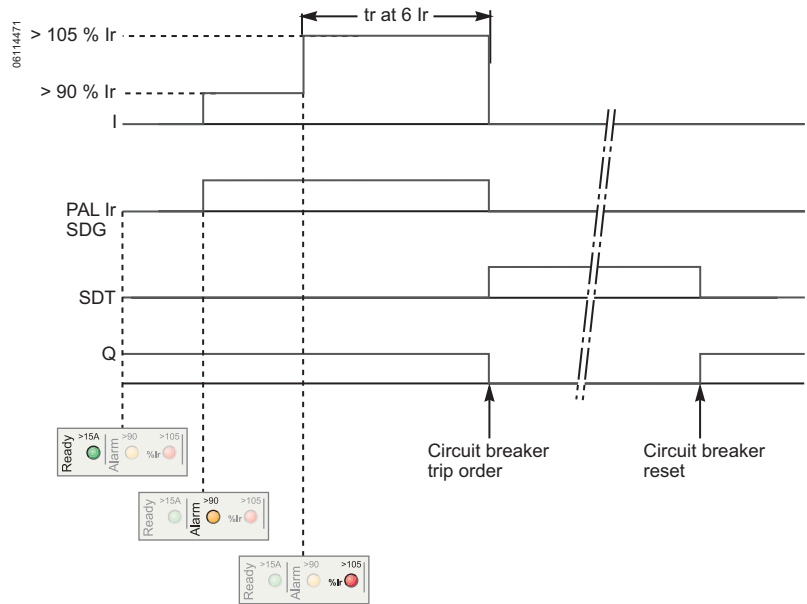

- I:** Charge Current
- PAL I<sub>r</sub>:** Thermal Overload Pre-Alarm
- SDG:** Ground-Fault Signal
- SDT:** Thermal-Fault Signal
- Q:** Circuit Breaker

# PowerPact™ H-, J-, and L-Frame Circuit Breakers Wiring Diagrams

## SDTAM Module with Micrologic M Trip Unit

**NOTE:** The diagram is shown with circuits de-energized, relays in normal position, and all devices open, connected, and charged.

### Symbols

**SD1, SD3:** SDTAM Module Power Supply  
**SD2:** Thermal Fault Signal (80 mA max.)  
**SD4:** Contactor Control Output (80 mA max.)

	SD2	SD4
<b>Micrologic 2 M</b>	SDT	KA1

Terminal connections shown as O must be connected by the customer.

### Connection

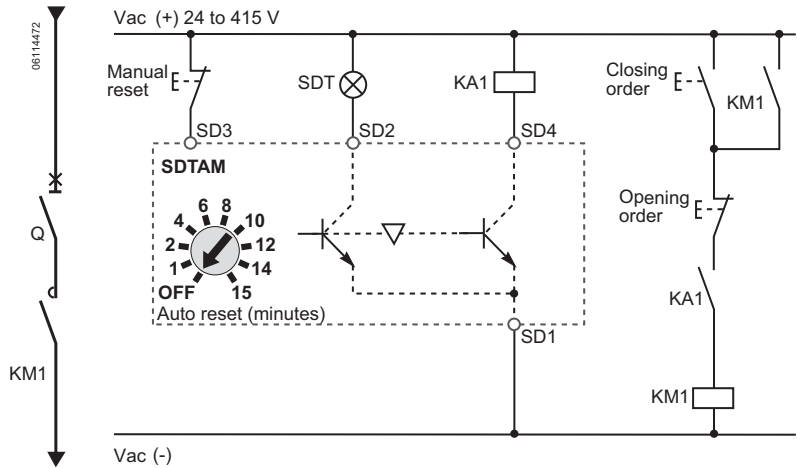

### Operation

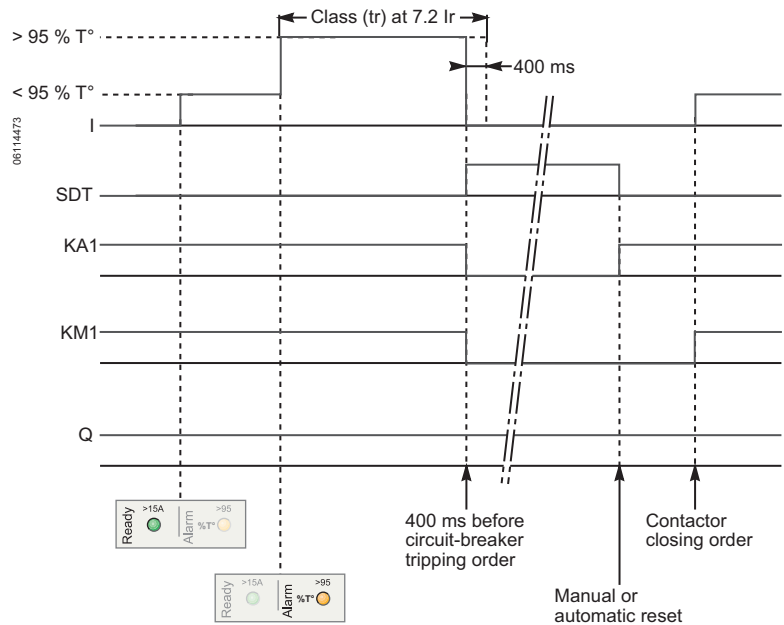

**I:** Charge Current  
**SDT:** Thermal Fault Signal  
**KA1:** Auxiliary Relay (RBN or RTBT Relay)  
**KM1:** Motor Contactor  
**Q:** Circuit Breaker

# PowerPact™ H-, J-, and L-Frame Circuit Breakers Wiring Diagrams

## Modbus™ Module

Detailed connection of the circuit breakers on communication network Modbus

### Connection

