

# Designing connections between a device and busbars

Fixed Masterpact 08-16

## Electrical characteristics

Masterpact NW 08 to 16  
Masterpact MTZ2 08 to 16  
Fixed

Vertical busbars on the left or right  
Linergy LGY, BS busbars  
Connections drawings supplied by  
Schneider Electric

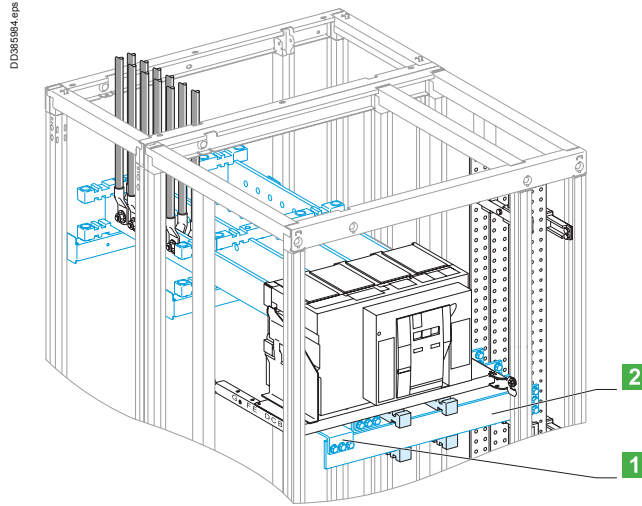

- 1 Liaison
- 2 Horizontal link.

Using the data below, it is possible to determine the size of the copper bars and the maximum permissible currents when making the connections to busbars for a vertical, fixed Masterpact NW08/16, front or rear connection, taking into account the ambient temperature around the switchboard and the IP value.

## Connection

Flat bars, 5 mm thick

Device		Permissible current (A)											
		Ambient temperature around the switchboard (1)											
		25 °C		30 °C		35 °C		40 °C		45 °C		50 °C	
		IP ≤ 31	IP > 31	IP ≤ 31	IP > 31	IP ≤ 31	IP > 31	IP ≤ 31	IP > 31	IP ≤ 31	IP > 31	IP ≤ 31	IP > 31
NW08 & MTZ2	Size per phase	1b 80 x 5	1b 80 x 5	1b 80 x 5	1b 80 x 5	1b 80 x 5	1b 80 x 5	1b 80 x 5	1b 80 x 5	1b 80 x 5	1b 80 x 5	1b 80 x 5	■
	I (A)	800	800	800	800	800	800	800	800	800	800	800	
NW10 & MTZ2	Size per phase	1b 80 x 5	1b 80 x 5	1b 80 x 5	1b 80 x 5	1b 80 x 5	1b 80 x 5	1b 80 x 5	1b 80 x 5	1b 80 x 5	1b 80 x 5	1b 80 x 5	■
	I (A)	1000	1000	1000	1000	1000	1000	1000	1000	1000	1000	1000	
NW12 & MTZ2	Size per phase	2b 80 x 5	2b 80 x 5	2b 80 x 5	2b 80 x 5	2b 80 x 5	2b 80 x 5	2b 80 x 5	2b 80 x 5	2b 80 x 5	2b 80 x 5	2b 80 x 5	■
	I (A)	1250	1250	1250	1250	1250	1250	1250	1250	1250	1250	1250	
NW16 & MTZ2	Size per phase	2b 80 x 5	2b 80 x 5	2b 80 x 5	2b 80 x 5	2b 80 x 5	2b 80 x 5	2b 80 x 5	2b 80 x 5	2b 80 x 5	2b 80 x 5	2b 80 x 5	■
	I (A)	1600	1600	1600	1570	1600	1520	1570	1470	1520	1420	1470	

## Horizontal link

Flat bars, 5 mm thick

Device		Permissible current (A)											
		Ambient temperature around the switchboard											
		25 °C		30 °C		35 °C		40 °C		45 °C		50 °C	
		IP ≤ 31	IP > 31	IP ≤ 31	IP > 31	IP ≤ 31	IP > 31	IP ≤ 31	IP > 31	IP ≤ 31	IP > 31	IP ≤ 31	IP > 31
NW08 & MTZ2	Size per phase	1b 80 x 5	1b 80 x 5	1b 80 x 5	1b 80 x 5	1b 80 x 5	1b 80 x 5	1b 80 x 5	1b 80 x 5	1b 80 x 5	1b 80 x 5	1b 80 x 5	■
	I (A)	800	800	800	800	800	800	800	800	800	800	800	
NW10 & MTZ2	Size per phase	1b 80 x 5	1b 80 x 5	1b 80 x 5	1b 80 x 5	1b 80 x 5	1b 80 x 5	1b 80 x 5	1b 80 x 5	1b 80 x 5	1b 80 x 5	1b 80 x 5	■
	I (A)	1000	1000	1000	1000	1000	1000	1000	1000	1000	1000	1000	
NW12 & MTZ2	Size per phase	2b 80 x 5	2b 80 x 5	2b 80 x 5	2b 80 x 5	2b 80 x 5	2b 80 x 5	2b 80 x 5	2b 80 x 5	2b 80 x 5	2b 80 x 5	2b 80 x 5	■
	I (A)	1250	1250	1250	1250	1250	1250	1250	1250	1250	1250	1250	
NW16 & MTZ2	Size per phase	2b 80 x 5	2b 80 x 5	2b 80 x 5	2b 80 x 5	2b 80 x 5	2b 80 x 5	2b 80 x 5	2b 80 x 5	2b 80 x 5	2b 80 x 5	2b 80 x 5	■
	I (A)	1600	1600	1600	1570	1600	1520	1570	1470	1520	1420	1470	

■ Connection impossible due to the operating-temperature limits of the devices installed in the switchboard.

(1) In the case of a door mounted at the rear of cubicle, add 10 °C.

Note: the values indicated above have been validated for Prisma P switchboards.

# Designing connections between a device and busbars

Fixed Masterpact 08-32

## Electrical characteristics

Masterpact NW 08 to 32  
Masterpact MTZ2 08 to 32  
Fixed

Vertical busbars on the left or right  
Linergy LGYE, LGY, BS busbars  
Connections drawings supplied by  
Schneider Electric

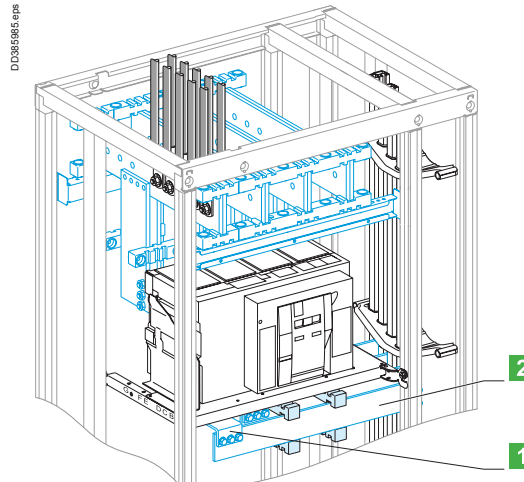

- 1 Connection.
- 2 Horizontal link.

Using the data below, it is possible to determine the size of the copper bars and the maximum permissible currents when making the connections to busbars for a vertical, fixed Masterpact NW08/32, front or rear connection, taking into account the ambient temperature around the switchboard and the IP value.

### Connection

Flat bars, 10 mm thick

Device		Permissible current (A)												
		Ambient temperature around the switchboard												
		25 °C		30 °C		35 °C		40 °C		45 °C		50 °C		
		IP ≤ 31	IP > 31	IP ≤ 31	IP > 31	IP ≤ 31	IP > 31	IP ≤ 31	IP > 31	IP ≤ 31	IP > 31	IP ≤ 31	IP > 31	
NW08 & MTZ2	Size per phase	1b 80 x 10	1b 80 x 10	1b 80 x 10	1b 80 x 10	1b 80 x 10	1b 80 x 10	1b 80 x 10	1b 80 x 10	1b 80 x 10	1b 80 x 10	1b 80 x 10	1b 80 x 10	■
	I (A)	800	800	800	800	800	800	800	800	800	800	800	800	
NW10 & MTZ2	Size per phase	1b 80 x 10	1b 80 x 10	1b 80 x 10	1b 80 x 10	1b 80 x 10	1b 80 x 10	1b 80 x 10	1b 80 x 10	1b 80 x 10	1b 80 x 10	1b 80 x 10	1b 80 x 10	■
	I (A)	1000	1000	1000	1000	1000	1000	1000	1000	1000	1000	1000	1000	
NW12 & MTZ2	Size per phase	1b 80 x 10	1b 80 x 10	1b 80 x 10	1b 80 x 10	1b 80 x 10	1b 80 x 10	1b 80 x 10	1b 80 x 10	1b 80 x 10	1b 80 x 10	1b 80 x 10	1b 80 x 10	■
	I (A)	1250	1250	1250	1250	1250	1250	1250	1250	1250	1250	1250	1250	
NW16 & MTZ2	Size per phase	1b 80 x 10	1b 80 x 10	1b 80 x 10	1b 80 x 10	1b 80 x 10	1b 80 x 10	1b 80 x 10	1b 80 x 10	1b 80 x 10	1b 80 x 10	1b 80 x 10	1b 80 x 10	■
	I (A)	1600	1600	1600	1570	1600	1520	1570	1470	1520	1420	1470	1470	
NW20 & MTZ2	Size per phase	2b 80 x 10	2b 80 x 10	2b 80 x 10	2b 80 x 10	2b 80 x 10	2b 80 x 10	2b 80 x 10	2b 80 x 10	2b 80 x 10	2b 80 x 10	2b 80 x 10	2b 80 x 10	■
	I (A)	2000	2000	2000	2000	2000	2000	2000	1950	2000	1900	1950	1950	
NW25 & MTZ2	Size per phase	2b 80 x 10	2b 80 x 10	2b 80 x 10	2b 80 x 10	2b 80 x 10	2b 80 x 10	2b 80 x 10	2b 80 x 10	2b 80 x 10	2b 80 x 10	2b 80 x 10	2b 80 x 10	■
	I (A)	2500	2500	2500	2500	2500	2460	2500	2380	2500	2300	2460	2460	
NW32 & MTZ2	Size per phase	3b 80 x 10	3b 80 x 10	3b 80 x 10	3b 80 x 10	3b 80 x 10	3b 80 x 10	3b 80 x 10	3b 80 x 10	3b 80 x 10	3b 80 x 10	3b 80 x 10	3b 80 x 10	■
	I (A)	3200	3000	3170	2910	3080	2820	3000	2730	2910	2630	2820	2820	

■ Connection impossible due to the operating-temperature limits of the devices installed in the switchboard.

### Horizontal link

Flat bars, 10 mm thick

Device		Permissible current (A)												
		Ambient temperature around the switchboard												
		25 °C		30 °C		35 °C		40 °C		45 °C		50 °C		
		IP ≤ 31	IP > 31	IP ≤ 31	IP > 31	IP ≤ 31	IP > 31	IP ≤ 31	IP > 31	IP ≤ 31	IP > 31	IP ≤ 31	IP > 31	
NW08 & MTZ2	Size per phase	1b 60 x 10	1b 60 x 10	1b 60 x 10	1b 60 x 10	1b 60 x 10	1b 60 x 10	1b 60 x 10	1b 60 x 10	1b 60 x 10	1b 60 x 10	1b 60 x 10	1b 60 x 10	■
	I (A)	800	800	800	800	800	800	800	800	800	800	800	800	
NW10 & MTZ2	Size per phase	1b 60 x 10	1b 60 x 10	1b 60 x 10	1b 60 x 10	1b 60 x 10	1b 60 x 10	1b 60 x 10	1b 60 x 10	1b 60 x 10	1b 60 x 10	1b 60 x 10	1b 60 x 10	■
	I (A)	1000	1000	1000	1000	1000	1000	1000	1000	1000	1000	1000	1000	
NW12 & MTZ2	Size per phase	1b 60 x 10	1b 60 x 10	1b 60 x 10	1b 60 x 10	1b 60 x 10	1b 60 x 10	1b 60 x 10	1b 60 x 10	1b 60 x 10	1b 60 x 10	1b 60 x 10	1b 60 x 10	■
	I (A)	1250	1250	1250	1250	1250	1250	1250	1250	1250	1250	1250	1250	
NW16 & MTZ2	Size per phase	1b 80 x 10	1b 80 x 10	1b 80 x 10	1b 80 x 10	1b 80 x 10	1b 80 x 10	1b 80 x 10	1b 80 x 10	1b 80 x 10	1b 80 x 10	1b 80 x 10	1b 80 x 10	■
	I (A)	1600	1600	1600	1570	1600	1520	1570	1470	1520	1420	1470	1470	
NW20 & MTZ2	Size per phase	2b 60 x 10	2b 60 x 10	2b 60 x 10	2b 60 x 10	2b 60 x 10	2b 60 x 10	2b 60 x 10	2b 60 x 10	2b 60 x 10	2b 60 x 10	2b 60 x 10	2b 60 x 10	■
	I (A)	2000	2000	2000	2000	2000	2000	2000	1950	2000	1900	1950	1950	
NW25 & MTZ2	Size per phase	2b 80 x 10	2b 80 x 10	2b 80 x 10	2b 80 x 10	2b 80 x 10	2b 80 x 10	2b 80 x 10	2b 80 x 10	2b 80 x 10	2b 80 x 10	2b 80 x 10	2b 80 x 10	■
	I (A)	2500	2500	2500	2500	2500	2460	2500	2380	2500	2300	2460	2460	
NW32 & MTZ2	Size per phase	2b 100x10	2b 100x10	2b 100x10	2b 100x10	2b 100x10	2b 100x10	2b 100x10	2b 100x10	2b 100x10	2b 100x10	2b 100x10	2b 100x10	■
	I (A)	3200	3000	3170	2910	3080	2820	3000	2730	2910	2630	2820	2820	

■ Connection impossible due to the operating-temperature limits of the devices installed in the switchboard.

Note: the values indicated above have been validated for Prisma P switchboards.

# Designing connections between a device and busbars

Drawout Masterpact 08-16

## Electrical characteristics

Masterpact NW 08 to 16  
Masterpact MTZ2 08 to 16  
Drawout

Vertical busbars on the left or right  
Linergy LGY, BS busbars  
Connections drawings supplied by  
Schneider Electric

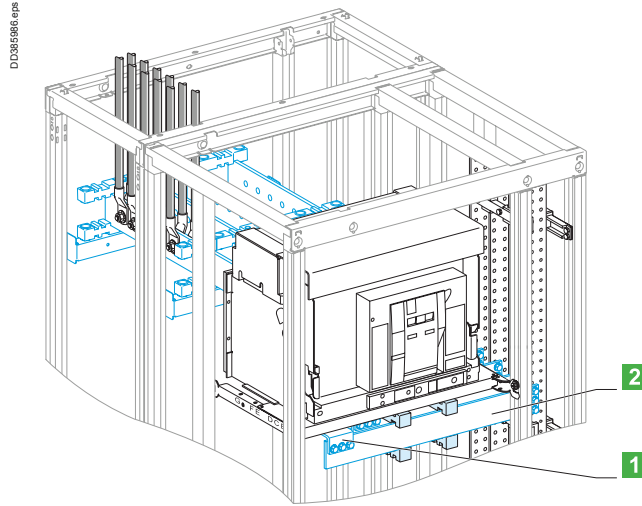

1 Connection.

2 Horizontal link.

Using the data below, it is possible to determine the size of the copper bars and the maximum permissible currents when making the connections to busbars for a vertical, drawout Masterpact NW08/16, front or rear connection, taking into account the ambient temperature around the switchboard and the IP value.

## Connection

Flat bars, 5 mm thick

Device		Permissible current (A)											
		Ambient temperature around the switchboard (1)											
		25 °C		30 °C		35 °C		40 °C		45 °C		50 °C	
		IP ≤ 31	IP > 31	IP ≤ 31	IP > 31	IP ≤ 31	IP > 31	IP ≤ 31	IP > 31	IP ≤ 31	IP > 31	IP ≤ 31	IP > 31
NW08 & MTZ2	Size per phase	1b 80 x 5	1b 80 x 5	1b 80 x 5	1b 80 x 5	1b 80 x 5	1b 80 x 5	1b 80 x 5	1b 80 x 5	1b 80 x 5	1b 80 x 5	1b 80 x 5	■
	I (A)	800	800	800	800	800	800	800	800	800	800	800	
NW10 & MTZ2	Size per phase	1b 80 x 5	1b 80 x 5	1b 80 x 5	1b 80 x 5	1b 80 x 5	1b 80 x 5	1b 80 x 5	1b 80 x 5	1b 80 x 5	1b 80 x 5	1b 80 x 5	■
	I (A)	1000	1000	1000	1000	1000	1000	1000	1000	1000	1000	1000	
NW12 & MTZ2	Size per phase	2b 80 x 5	2b 80 x 5	2b 80 x 5	2b 80 x 5	2b 80 x 5	2b 80 x 5	2b 80 x 5	2b 80 x 5	2b 80 x 5	2b 80 x 5	2b 80 x 5	■
	I (A)	1250	1250	1250	1250	1250	1230	1250	1200	1230	1160	1200	
NW16 & MTZ2	Size per phase	2b 80 x 5	2b 80 x 5	2b 80 x 5	2b 80 x 5	2b 80 x 5	2b 80 x 5	2b 80 x 5	2b 80 x 5	2b 80 x 5	2b 80 x 5	2b 80 x 5	■
	I (A)	1560	1480	1520	1430	1480	1380	1430	1330	1380	1280	1330	

■ Connection impossible due to the operating-temperature limits of the devices installed in the switchboard.

## Horizontal link

Flat bars, 5 mm thick

Device		Permissible current (A)											
		Ambient temperature around the switchboard											
		25 °C		30 °C		35 °C		40 °C		45 °C		50 °C	
		IP ≤ 31	IP > 31	IP ≤ 31	IP > 31	IP ≤ 31	IP > 31	IP ≤ 31	IP > 31	IP ≤ 31	IP > 31	IP ≤ 31	IP > 31
NW08 & MTZ2	Size per phase	1b 80 x 5	1b 80 x 5	1b 80 x 5	1b 80 x 5	1b 80 x 5	1b 80 x 5	1b 80 x 5	1b 80 x 5	1b 80 x 5	1b 80 x 5	1b 80 x 5	■
	I (A)	800	800	800	800	800	800	800	800	800	800	800	
NW10 & MTZ2	Size per phase	1b 80 x 5	1b 80 x 5	1b 80 x 5	1b 80 x 5	1b 80 x 5	1b 80 x 5	1b 80 x 5	1b 80 x 5	1b 80 x 5	1b 80 x 5	1b 80 x 5	■
	I (A)	1000	1000	1000	1000	1000	1000	1000	1000	1000	1000	1000	
NW12 & MTZ2	Size per phase	2b 80 x 5	2b 80 x 5	2b 80 x 5	2b 80 x 5	2b 80 x 5	2b 80 x 5	2b 80 x 5	2b 80 x 5	2b 80 x 5	2b 80 x 5	2b 80 x 5	■
	I (A)	1250	1250	1250	1250	1250	1230	1250	1200	1230	1160	1200	
NW16 & MTZ2	Size per phase	2b 80 x 5	2b 80 x 5	2b 80 x 5	2b 80 x 5	2b 80 x 5	2b 80 x 5	2b 80 x 5	2b 80 x 5	2b 80 x 5	2b 80 x 5	2b 80 x 5	■
	I (A)	1560	1480	1520	1430	1480	1380	1430	1330	1380	1280	1330	

■ Connection impossible due to the operating-temperature limits of the devices installed in the switchboard.

(1) In the case of a door mounted at the rear of cubicle, add 10 °C.

Note: the values indicated above have been validated for Prisma P switchboards.

# Designing connections between a device and busbars

Drawout Masterpact 08-32

## Electrical characteristics

Masterpact NW 08 to 32  
Masterpact MTZ2 08 to 32  
Drawout

Vertical busbars on the left or right  
Linergy LGYE, LGY, BS busbars  
Connections drawings supplied by  
Schneider Electric

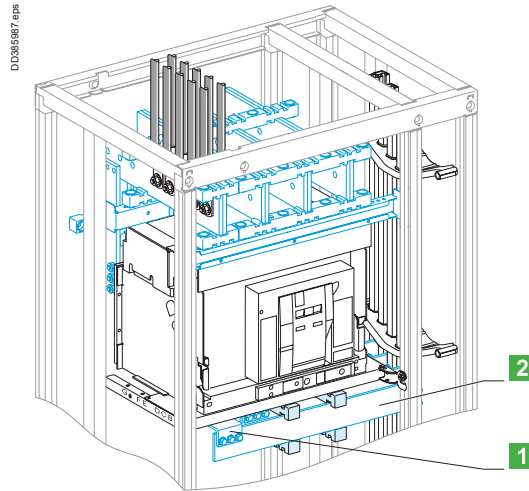

- 1 Connection.
- 2 Horizontal link.

Using the data below, it is possible to determine the size of the copper bars and the maximum permissible currents when making the connections to busbars for a vertical, drawout Masterpact NW08/32, front or rear connection, taking into account the ambient temperature around the switchboard and the IP value.

### Connection

Flat bars, 10 mm thick

Device		Permissible current (A)											
		Ambient temperature around the switchboard											
		25 °C		30 °C		35 °C		40 °C		45 °C		50 °C	
		IP ≤ 31	IP > 31	IP ≤ 31	IP > 31	IP ≤ 31	IP > 31	IP ≤ 31	IP > 31	IP ≤ 31	IP > 31	IP ≤ 31	IP > 31
NW08 & MTZ2	Size per phase	1b 80 x 10	1b 80 x 10	1b 80 x 10	1b 80 x 10	1b 80 x 10	1b 80 x 10	1b 80 x 10	1b 80 x 10	1b 80 x 10	1b 80 x 10	1b 80 x 10	1b 80 x 10
	I (A)	800	800	800	800	800	800	800	800	800	800	800	800
NW10 & MTZ2	Size per phase	1b 80 x 10	1b 80 x 10	1b 80 x 10	1b 80 x 10	1b 80 x 10	1b 80 x 10	1b 80 x 10	1b 80 x 10	1b 80 x 10	1b 80 x 10	1b 80 x 10	1b 80 x 10
	I (A)	1000	1000	1000	1000	1000	1000	1000	1000	1000	1000	1000	1000
NW12 & MTZ2	Size per phase	1b 80 x 10	1b 80 x 10	1b 80 x 10	1b 80 x 10	1b 80 x 10	1b 80 x 10	1b 80 x 10	1b 80 x 10	1b 80 x 10	1b 80 x 10	1b 80 x 10	1b 80 x 10
	I (A)	1250	1250	1250	1210	1250	1180	1210	1140	1180	1100	1140	1140
NW16 & MTZ2	Size per phase	1b 80 x 10	1b 80 x 10	1b 80 x 10	1b 80 x 10	1b 80 x 10	1b 80 x 10	1b 80 x 10	1b 80 x 10	1b 80 x 10	1b 80 x 10	1b 80 x 10	1b 80 x 10
	I (A)	1560	1480	1520	1430	1480	1380	1430	1330	1380	1280	1330	1330
NW20 & MTZ2	Size per phase	2b 80 x 10	2b 80 x 10	2b 80 x 10	2b 80 x 10	2b 80 x 10	2b 80 x 10	2b 80 x 10	2b 80 x 10	2b 80 x 10	2b 80 x 10	2b 80 x 10	2b 80 x 10
	I (A)	2000	2000	2000	1950	2000	1900	1950	1830	1900	1760	1830	1830
NW25 & MTZ2	Size per phase	2b 80 x 10	2b 80 x 10	2b 80 x 10	2b 80 x 10	2b 80 x 10	2b 80 x 10	2b 80 x 10	2b 80 x 10	2b 80 x 10	2b 80 x 10	2b 80 x 10	2b 80 x 10
	I (A)	2470	2280	2410	2210	2350	2140	2280	2070	2210	2000	2140	2140
NW32 & MTZ2	Size per phase	3b 80 x 10	3b 80 x 10	3b 80 x 10	3b 80 x 10	3b 80 x 10	3b 80 x 10	3b 80 x 10	3b 80 x 10	3b 80 x 10	3b 80 x 10	3b 80 x 10	3b 80 x 10
	I (A)	2960	2730	2890	2630	2820	2530	2730	2450	2630	2370	2530	2530

■ Connection impossible due to the operating-temperature limits of the devices installed in the switchboard.

### Horizontal link

Flat bars, 10 mm thick

Device		Permissible current (A)											
		Ambient temperature around the switchboard											
		25 °C		30 °C		35 °C		40 °C		45 °C		50 °C	
		IP ≤ 31	IP > 31	IP ≤ 31	IP > 31	IP ≤ 31	IP > 31	IP ≤ 31	IP > 31	IP ≤ 31	IP > 31	IP ≤ 31	IP > 31
NW08 & MTZ2	Size per phase	1b 60 x 10	1b 60 x 10	1b 60 x 10	1b 60 x 10	1b 60 x 10	1b 60 x 10	1b 60 x 10	1b 60 x 10	1b 60 x 10	1b 60 x 10	1b 60 x 10	1b 60 x 10
	I (A)	800	800	800	800	800	800	800	800	800	800	800	800
NW10 & MTZ2	Size per phase	1b 60 x 10	1b 60 x 10	1b 60 x 10	1b 60 x 10	1b 60 x 10	1b 60 x 10	1b 60 x 10	1b 60 x 10	1b 60 x 10	1b 60 x 10	1b 60 x 10	1b 60 x 10
	I (A)	1000	1000	1000	1000	1000	1000	1000	1000	1000	1000	1000	1000
NW12 & MTZ2	Size per phase	1b 60 x 10	1b 60 x 10	1b 60 x 10	1b 60 x 10	1b 60 x 10	1b 60 x 10	1b 60 x 10	1b 60 x 10	1b 60 x 10	1b 60 x 10	1b 60 x 10	1b 60 x 10
	I (A)	1250	1250	1250	1210	1250	1180	1210	1140	1180	1100	1140	1140
NW16 & MTZ2	Size per phase	1b 80 x 10	1b 80 x 10	1b 80 x 10	1b 80 x 10	1b 80 x 10	1b 80 x 10	1b 80 x 10	1b 80 x 10	1b 80 x 10	1b 80 x 10	1b 80 x 10	1b 80 x 10
	I (A)	1560	1480	1520	1430	1480	1380	1430	1330	1380	1280	1330	1330
NW20 & MTZ2	Size per phase	2b 60 x 10	2b 60 x 10	2b 60 x 10	2b 60 x 10	2b 60 x 10	2b 60 x 10	2b 60 x 10	2b 60 x 10	2b 60 x 10	2b 60 x 10	2b 60 x 10	2b 60 x 10
	I (A)	2000	2000	2000	1950	2000	1900	1950	1830	1900	1760	1830	1830
NW25 & MTZ2	Size per phase	2b 80 x 10	2b 80 x 10	2b 80 x 10	2b 80 x 10	2b 80 x 10	2b 80 x 10	2b 80 x 10	2b 80 x 10	2b 80 x 10	2b 80 x 10	2b 80 x 10	2b 80 x 10
	I (A)	2470	2280	2410	2210	2350	2140	2280	2070	2210	2000	2140	2140
NW32 & MTZ2	Size per phase	2b 100x10	2b 100x10	2b 100x10	2b 100x10	2b 100x10	2b 100x10	2b 100x10	2b 100x10	2b 100x10	2b 100x10	2b 100x10	2b 100x10
	I (A)	2960	2730	2890	2630	2820	2530	2730	2450	2630	2370	2530	2530

■ Connection impossible due to the operating-temperature limits of the devices installed in the switchboard.

Note: the values indicated above have been validated for Prisma P switchboards.

# Designing connections between a device and busbars

## Dedicated cubicle

Fixed Masterpact 08-32

Electrical characteristics

Masterpact NW 08 to 32  
Masterpact MTZ2 08 to 32  
Fixed

Dedicated cubicle  
Linergy LGYE, BS busbars  
Connections drawings supplied by  
Schneider Electric

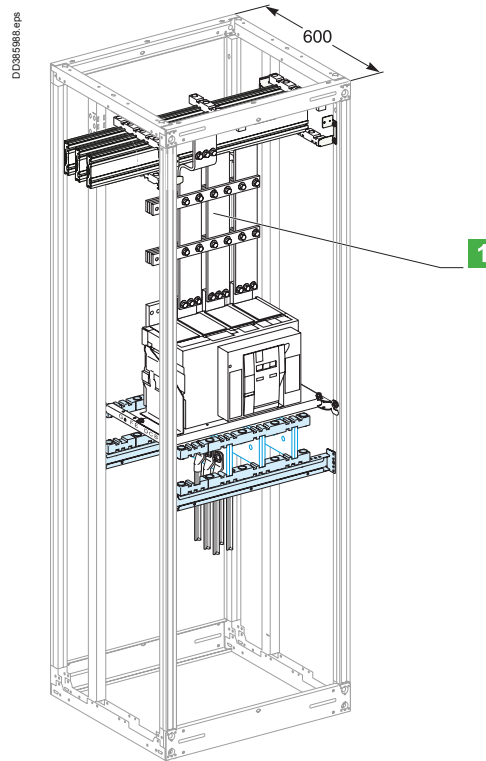

## Connection

Flat bars, 10 mm thick

Device		Permissible current (A)												
		Ambient temperature around the switchboard												
		25 °C		30 °C		35 °C		40 °C		45 °C		50 °C		
		IP ≤ 31	IP > 31	IP ≤ 31	IP > 31	IP ≤ 31	IP > 31	IP ≤ 31	IP > 31	IP ≤ 31	IP > 31	IP ≤ 31	IP > 31	
NW08 & MTZ2	Size per phase	1b 80 x 10	1b 80 x 10	1b 80 x 10	1b 80 x 10	1b 80 x 10	1b 80 x 10	1b 80 x 10	1b 80 x 10	1b 80 x 10	1b 80 x 10	1b 80 x 10	1b 80 x 10	■
	I (A)	800	800	800	800	800	800	800	800	800	800	800		
NW10 & MTZ2	Size per phase	1b 80 x 10	1b 80 x 10	1b 80 x 10	1b 80 x 10	1b 80 x 10	1b 80 x 10	1b 80 x 10	1b 80 x 10	1b 80 x 10	1b 80 x 10	1b 80 x 10	1b 80 x 10	■
	I (A)	1000	1000	1000	1000	1000	1000	1000	1000	1000	1000	1000		
NW12 & MTZ2	Size per phase	1b 80 x 10	1b 80 x 10	1b 80 x 10	1b 80 x 10	1b 80 x 10	1b 80 x 10	1b 80 x 10	1b 80 x 10	1b 80 x 10	1b 80 x 10	1b 80 x 10	1b 80 x 10	■
	I (A)	1250	1250	1250	1250	1250	1250	1250	1250	1250	1250	1250		
NW16 & MTZ2	Size per phase	1b 80 x 10	1b 80 x 10	1b 80 x 10	1b 80 x 10	1b 80 x 10	1b 80 x 10	1b 80 x 10	1b 80 x 10	1b 80 x 10	1b 80 x 10	1b 80 x 10	1b 80 x 10	■
	I (A)	1600	1600	1600	1570	1600	1520	1570	1470	1520	1420	1470		
NW20 & MTZ2	Size per phase	2b 80 x 10	2b 80 x 10	2b 80 x 10	2b 80 x 10	2b 80 x 10	2b 80 x 10	2b 80 x 10	2b 80 x 10	2b 80 x 10	2b 80 x 10	2b 80 x 10	2b 80 x 10	■
	I (A)	2000	2000	2000	2000	2000	2000	2000	1950	2000	1900	1950		
NW25 & MTZ2	Size per phase	2b 80 x 10	2b 80 x 10	2b 80 x 10	2b 80 x 10	2b 80 x 10	2b 80 x 10	2b 80 x 10	2b 80 x 10	2b 80 x 10	2b 80 x 10	2b 80 x 10	2b 80 x 10	■
	I (A)	2500	2500	2500	2500	2500	2460	2500	2380	2500	2300	2460		
NW32 & MTZ2	Size per phase	3b 80 x 10	3b 80 x 10	3b 80 x 10	3b 80 x 10	3b 80 x 10	3b 80 x 10	3b 80 x 10	3b 80 x 10	3b 80 x 10	3b 80 x 10	3b 80 x 10	3b 80 x 10	■
	I (A)	3200	3000	3170	2910	3080	2820	3000	2730	2910	2630	2820		

■ Connection impossible due to the operating-temperature limits of the devices installed in the switchboard.

Note: contact Schneider Electric for 4000 A dedicated cubicle

# Designing connections between a device and busbars

## Dedicated cubicle

Drawout Masterpact 08-32

### Electrical characteristics

Masterpact NW 08 to 32  
Masterpact MTZ2 08 to 32  
Drawout

Dedicated cubicle  
Linergy LGYE, BS busbars  
Connections drawings supplied by  
Schneider Electric

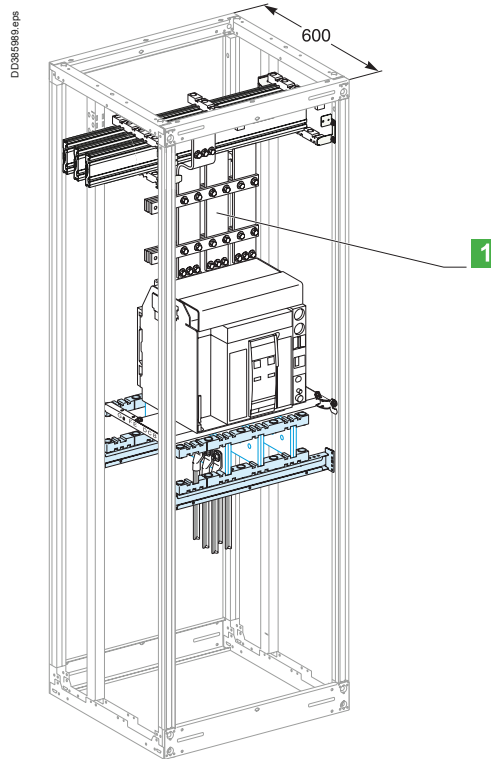

## Connection

Flat bars, 10 mm thick

Device		Permissible current (A)											
		Ambient temperature around the switchboard											
		25 °C		30 °C		35 °C		40 °C		45 °C		50 °C	
		IP ≤ 31	IP > 31	IP ≤ 31	IP > 31	IP ≤ 31	IP > 31	IP ≤ 31	IP > 31	IP ≤ 31	IP > 31	IP ≤ 31	IP > 31
NW08 & MTZ2	Size per phase	1b 80 x 10	1b 80 x 10	1b 80 x 10	1b 80 x 10	1b 80 x 10	1b 80 x 10	1b 80 x 10	1b 80 x 10	1b 80 x 10	1b 80 x 10	1b 80 x 10	1b 80 x 10
	I (A)	800	800	800	800	800	800	800	800	800	800	800	■
NW10 & MTZ2	Size per phase	1b 80 x 10	1b 80 x 10	1b 80 x 10	1b 80 x 10	1b 80 x 10	1b 80 x 10	1b 80 x 10	1b 80 x 10	1b 80 x 10	1b 80 x 10	1b 80 x 10	1b 80 x 10
	I (A)	1000	1000	1000	1000	1000	1000	1000	1000	1000	1000	1000	■
NW12 & MTZ2	Size per phase	1b 80 x 10	1b 80 x 10	1b 80 x 10	1b 80 x 10	1b 80 x 10	1b 80 x 10	1b 80 x 10	1b 80 x 10	1b 80 x 10	1b 80 x 10	1b 80 x 10	1b 80 x 10
	I (A)	1250	1250	1250	1210	1250	1180	1210	1140	1180	1100	1140	■
NW16 & MTZ2	Size per phase	1b 80 x 10	1b 80 x 10	1b 80 x 10	1b 80 x 10	1b 80 x 10	1b 80 x 10	1b 80 x 10	1b 80 x 10	1b 80 x 10	1b 80 x 10	1b 80 x 10	1b 80 x 10
	I (A)	1560	1480	1520	1430	1480	1380	1430	1330	1380	1280	1330	■
NW20 & MTZ2	Size per phase	2b 80 x 10	2b 80 x 10	2b 80 x 10	2b 80 x 10	2b 80 x 10	2b 80 x 10	2b 80 x 10	2b 80 x 10	2b 80 x 10	2b 80 x 10	2b 80 x 10	2b 80 x 10
	I (A)	2000	2000	2000	1950	2000	1900	1950	1830	1900	1760	1830	■
NW25 & MTZ2	Size per phase	2b 80 x 10	2b 80 x 10	2b 80 x 10	2b 80 x 10	2b 80 x 10	2b 80 x 10	2b 80 x 10	2b 80 x 10	2b 80 x 10	2b 80 x 10	2b 80 x 10	2b 80 x 10
	I (A)	2470	2280	2410	2210	2350	2140	2280	2070	2210	2000	2140	■
NW32 & MTZ2	Size per phase	3b 80 x 10	3b 80 x 10	3b 80 x 10	3b 80 x 10	3b 80 x 10	3b 80 x 10	3b 80 x 10	3b 80 x 10	3b 80 x 10	3b 80 x 10	3b 80 x 10	3b 80 x 10
	I (A)	2960	2730	2890	2630	2820	2530	2730	2450	2630	2370	2530	■

■ Connection impossible due to the operating-temperature limits of the devices installed in the switchboard.

Note: contact Schneider Electric for 4000 A dedicated cubicle

# Designing connections between a device and busbars

Fixed Masterpact 06-16

## Electrical characteristics

Masterpact NT 06 to 16  
Masterpact MTZ1 06 to 16  
Fixed

Vertical busbars on the left or right  
Linergy BS busbars  
Connections drawings supplied by  
Schneider Electric

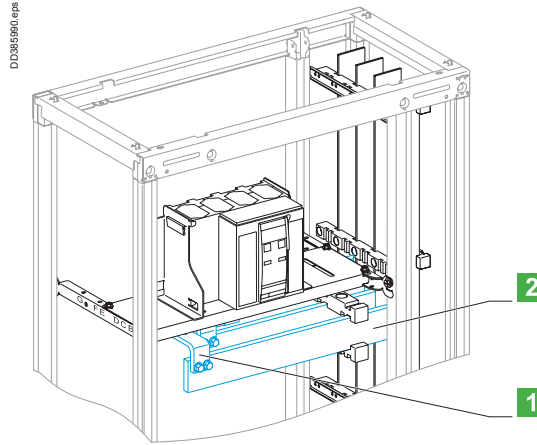

- 1 Connection.
- 2 Horizontal link.

Using the data below, it is possible to determine the size of the copper bars and the maximum permissible currents when making the connections to busbars for a vertical, fixed Masterpact NT06/NT16, taking into account the ambient temperature around the switchboard and the IP value.

### Connection

Flat bars, 5 mm thick

Device		Permissible current (A)											
		Ambient temperature around the switchboard											
		25 °C		30 °C		35 °C		40 °C		45 °C		50 °C	
		IP ≤ 31	IP > 31	IP ≤ 31	IP > 31	IP ≤ 31	IP > 31	IP ≤ 31	IP > 31	IP ≤ 31	IP > 31	IP ≤ 31	IP > 31
NT06 & MTZ1	Size per phase	1b 50 x 5	1b 50 x 5	1b 50 x 5	1b 50 x 5	1b 50 x 5	1b 50 x 5	1b 50 x 5	1b 50 x 5	1b 50 x 5	1b 50 x 5	1b 50 x 5	■
	I (A)	630	630	630	630	630	630	630	630	630	630	630	
NT08 & MTZ1	Size per phase	2b 50 x 5	2b 50 x 5	2b 50 x 5	2b 50 x 5	2b 50 x 5	2b 50 x 5	2b 50 x 5	2b 50 x 5	2b 50 x 5	2b 50 x 5	2b 50 x 5	■
	I (A)	800	800	800	800	800	800	800	800	800	800	800	
NT10 & MTZ1	Size per phase	2b 50 x 5	2b 50 x 5	2b 50 x 5	2b 50 x 5	2b 50 x 5	2b 50 x 5	2b 50 x 5	2b 50 x 5	2b 50 x 5	2b 50 x 5	2b 50 x 5	■
	I (A)	1000	1000	1000	1000	1000	1000	1000	1000	1000	1000	1000	
NT12 & MTZ1	Size per phase	3b 50 x 5	3b 50 x 5	3b 50 x 5	3b 50 x 5	3b 50 x 5	3b 50 x 5	3b 50 x 5	3b 50 x 5	3b 50 x 5	3b 50 x 5	3b 50 x 5	■
	I (A)	1250	1250	1250	1250	1250	1250	1250	1250	1250	1200	1250	
NT16 & MTZ1 (1)	Size per phase	4b 50 x 5	4b 50 x 5	4b 50 x 5	4b 50 x 5	4b 50 x 5	4b 50 x 5	4b 50 x 5	4b 50 x 5	4b 50 x 5	4b 50 x 5	4b 50 x 5	■
	I (A)	1600	1570	1600	1520	1570	1470	1520	1420	1470	1370	1420	

■ Connection impossible due to the operating-temperature limits of the devices installed in the switchboard.

### Horizontal link

Flat bars, 5 mm thick

Device		Permissible current (A)											
		Ambient temperature around the switchboard											
		25 °C		30 °C		35 °C		40 °C		45 °C		50 °C	
		IP ≤ 31	IP > 31	IP ≤ 31	IP > 31	IP ≤ 31	IP > 31	IP ≤ 31	IP > 31	IP ≤ 31	IP > 31	IP ≤ 31	IP > 31
NT06 & MTZ1	Size per phase	1b 60 x 5	1b 60 x 5	1b 60 x 5	1b 60 x 5	1b 60 x 5	1b 60 x 5	1b 60 x 5	1b 60 x 5	1b 60 x 5	1b 60 x 5	1b 60 x 5	■
	I (A)	630	630	630	630	630	630	630	630	630	630	630	
NT08 & MTZ1	Size per phase	1b 80 x 5	1b 80 x 5	1b 80 x 5	1b 80 x 5	1b 80 x 5	1b 80 x 5	1b 80 x 5	1b 80 x 5	1b 80 x 5	1b 80 x 5	1b 80 x 5	■
	I (A)	800	800	800	800	800	800	800	800	800	800	800	
NT10 & MTZ1	Size per phase	2b 50 x 5	2b 50 x 5	2b 50 x 5	2b 50 x 5	2b 50 x 5	2b 50 x 5	2b 50 x 5	2b 50 x 5	2b 50 x 5	2b 50 x 5	2b 50 x 5	■
	I (A)	1000	1000	1000	1000	1000	1000	1000	1000	1000	1000	1000	
NT12 & MTZ1	Size per phase	2b 60 x 5	2b 60 x 5	2b 60 x 5	2b 60 x 5	2b 60 x 5	2b 60 x 5	2b 60 x 5	2b 60 x 5	2b 60 x 5	2b 60 x 5	2b 60 x 5	■
	I (A)	1250	1250	1250	1250	1250	1250	1250	1250	1250	1200	1250	
NT16 & MTZ1	Size per phase	2b 80 x 5	2b 80 x 5	2b 80 x 5	2b 80 x 5	2b 80 x 5	2b 80 x 5	2b 80 x 5	2b 80 x 5	2b 80 x 5	2b 80 x 5	2b 80 x 5	■
	I (A)	1600	1570	1600	1520	1570	1470	1520	1420	1470	1370	1420	

■ Connection impossible due to the operating-temperature limits of the devices installed in the switchboard.

(1) Make the neutral connection with two bars, 50 x 5 mm.

Note: the values indicated above have been validated for Prisma P switchboards.

## Designing connections between a device and busbars

Fixed Masterpact 06-16

## Electrical characteristics

## Connection

Flat bars, 10 mm thick

Device		Permissible current (A)											
		Ambient temperature around the switchboard											
		25 °C		30 °C		35 °C		40 °C		45 °C		50 °C	
		IP ≤ 31	IP > 31	IP ≤ 31	IP > 31	IP ≤ 31	IP > 31	IP ≤ 31	IP > 31	IP ≤ 31	IP > 31	IP ≤ 31	IP > 31
NT06 & MTZ1	Size per phase	1b 50 x 10	1b 50 x 10	1b 50 x 10	1b 50 x 10	1b 50 x 10	1b 50 x 10	1b 50 x 10	1b 50 x 10	1b 50 x 10	1b 50 x 10	1b 50 x 10	1b 50 x 10
	I (A)	630	630	630	630	630	630	630	630	630	630	630	630
NT08 & MTZ1	Size per phase	1b 50 x 10	1b 50 x 10	1b 50 x 10	1b 50 x 10	1b 50 x 10	1b 50 x 10	1b 50 x 10	1b 50 x 10	1b 50 x 10	1b 50 x 10	1b 50 x 10	1b 50 x 10
	I (A)	800	800	800	800	800	800	800	800	800	800	800	800
NT10 & MTZ1	Size per phase	1b 50 x 10	1b 50 x 10	1b 50 x 10	1b 50 x 10	1b 50 x 10	1b 50 x 10	1b 50 x 10	1b 50 x 10	1b 50 x 10	1b 50 x 10	1b 50 x 10	1b 50 x 10
	I (A)	1000	1000	1000	1000	1000	1000	1000	1000	1000	1000	1000	1000
NT12 & MTZ1	Size per phase	1b 50 x 10	1b 50 x 10	1b 50 x 10	1b 50 x 10	1b 50 x 10	1b 50 x 10	1b 50 x 10	1b 50 x 10	1b 50 x 10	1b 50 x 10	1b 50 x 10	1b 50 x 10
	I (A)	1250	1250	1250	1250	1250	1250	1250	1250	1250	1180	1230	
NT16 & MTZ1 (1)	Size per phase	2b 50 x 10	2b 50 x 10	2b 50 x 10	2b 50 x 10	2b 50 x 10	2b 50 x 10	2b 50 x 10	2b 50 x 10	2b 50 x 10	2b 50 x 10	2b 50 x 10	2b 50 x 10
	I (A)	1600	1570	1600	1520	1570	1470	1520	1420	1470	1370	1420	

■ Connection impossible due to the operating-temperature limits of the devices installed in the switchboard.

## Horizontal link

Flat bars, 10 mm thick

Device		Permissible current (A)											
		Ambient temperature around the switchboard											
		25 °C		30 °C		35 °C		40 °C		45 °C		50 °C	
		IP ≤ 31	IP > 31	IP ≤ 31	IP > 31	IP ≤ 31	IP > 31	IP ≤ 31	IP > 31	IP ≤ 31	IP > 31	IP ≤ 31	IP > 31
NT06 & MTZ1	Size per phase	1b 50 x 10	1b 50 x 10	1b 50 x 10	1b 50 x 10	1b 50 x 10	1b 50 x 10	1b 50 x 10	1b 50 x 10	1b 50 x 10	1b 50 x 10	1b 50 x 10	1b 50 x 10
	I (A)	630	630	630	630	630	630	630	630	630	630	630	630
NT08 & MTZ1	Size per phase	1b 50 x 10	1b 50 x 10	1b 50 x 10	1b 50 x 10	1b 50 x 10	1b 50 x 10	1b 50 x 10	1b 50 x 10	1b 50 x 10	1b 50 x 10	1b 50 x 10	1b 50 x 10
	I (A)	800	800	800	800	800	800	800	800	800	800	800	800
NT10 & MTZ1	Size per phase	1b 50 x 10	1b 50 x 10	1b 50 x 10	1b 50 x 10	1b 50 x 10	1b 50 x 10	1b 50 x 10	1b 50 x 10	1b 50 x 10	1b 50 x 10	1b 50 x 10	1b 50 x 10
	I (A)	1000	1000	1000	1000	1000	1000	1000	1000	1000	960	1000	
NT12 & MTZ1	Size per phase	1b 50 x 10	1b 50 x 10	1b 50 x 10	1b 50 x 10	1b 50 x 10	1b 50 x 10	1b 50 x 10	1b 50 x 10	1b 50 x 10	1b 50 x 10	1b 50 x 10	1b 50 x 10
	I (A)	1250	1250	1250	1250	1250	1210	1250	1160	1210	1110	1160	
NT16 & MTZ1	Size per phase	2b 50 x 10	2b 50 x 10	2b 50 x 10	2b 50 x 10	2b 50 x 10	2b 50 x 10	2b 50 x 10	2b 50 x 10	2b 50 x 10	2b 50 x 10	2b 50 x 10	2b 50 x 10
	I (A)	1560	1430	1520	1430	1480	1380	1430	1330	1380	1280	1330	

■ Connection impossible due to the operating-temperature limits of the devices installed in the switchboard.

(1) Make the neutral connection with one bar, 50 x 10 mm.

Note: the values indicated above have been validated for Prisma P switchboards.

# Designing connections between a device and busbars

Drawout Masterpact 06-16

## Electrical characteristics

Masterpact NT 06 to 16  
Masterpact MTZ1 06 to 16  
Drawout

Vertical busbars on the left or right  
Linergy BS busbars  
Connections drawings supplied by  
Schneider Electric

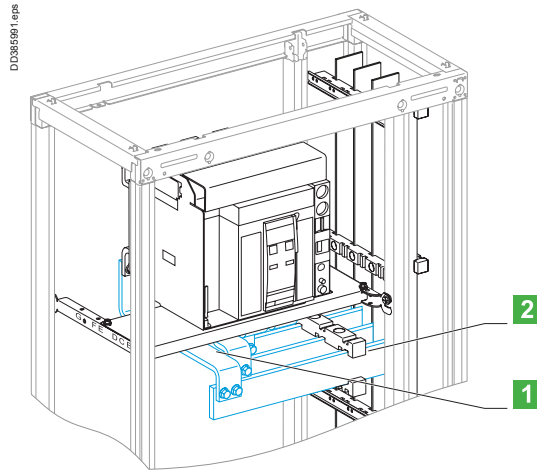

- 1** Connection.
- 2** Horizontal link.

Using the data below, it is possible to determine the size of the copper bars and the maximum permissible currents when making the connections to busbars for a vertical, drawout Masterpact NT06/NT16, taking into account the ambient temperature around the switchboard and the IP value.

### Connection

Flat bars, 5 mm thick

Device		Permissible current (A)											
		Ambient temperature around the switchboard											
		25 °C		30 °C		35 °C		40 °C		45 °C		50 °C	
		IP ≤ 31	IP > 31	IP ≤ 31	IP > 31	IP ≤ 31	IP > 31	IP ≤ 31	IP > 31	IP ≤ 31	IP > 31	IP ≤ 31	IP > 31
NT06 & MTZ1	Size per phase	1b 50 x 5	1b 50 x 5	1b 50 x 5	1b 50 x 5	1b 50 x 5	1b 50 x 5	1b 50 x 5	1b 50 x 5	1b 50 x 5	1b 50 x 5	1b 50 x 5	■
	I (A)	630	630	630	630	630	630	630	630	630	630	630	
NT08 & MTZ1	Size per phase	2b 50 x 5	2b 50 x 5	2b 50 x 5	2b 50 x 5	2b 50 x 5	2b 50 x 5	2b 50 x 5	2b 50 x 5	2b 50 x 5	2b 50 x 5	2b 50 x 5	■
	I (A)	800	800	800	800	800	800	800	800	800	800	800	
NT10 & MTZ1	Size per phase	2b 50 x 5	2b 50 x 5	2b 50 x 5	2b 50 x 5	2b 50 x 5	2b 50 x 5	2b 50 x 5	2b 50 x 5	2b 50 x 5	2b 50 x 5	2b 50 x 5	■
	I (A)	1000	1000	1000	1000	1000	1000	1000	1000	1000	960	1000	
NT12 & MTZ1	Size per phase	3b 50 x 5	3b 50 x 5	3b 50 x 5	3b 50 x 5	3b 50 x 5	3b 50 x 5	3b 50 x 5	3b 50 x 5	3b 50 x 5	3b 50 x 5	3b 50 x 5	■
	I (A)	1250	1250	1250	1250	1250	1230	1250	1180	1230	1130	1180	
NT16 & MTZ1 (1)	Size per phase	4b 50 x 5	4b 50 x 5	4b 50 x 5	4b 50 x 5	4b 50 x 5	4b 50 x 5	4b 50 x 5	4b 50 x 5	4b 50 x 5	4b 50 x 5	4b 50 x 5	■
	I (A)	1560	1430	1520	1430	1480	1380	1430	1330	1380	1280	1330	

■ Connection impossible due to the operating-temperature limits of the devices installed in the switchboard.

### Horizontal link

Flat bars, 5 mm thick

Device		Permissible current (A)											
		Ambient temperature around the switchboard											
		25 °C		30 °C		35 °C		40 °C		45 °C		50 °C	
		IP ≤ 31	IP > 31	IP ≤ 31	IP > 31	IP ≤ 31	IP > 31	IP ≤ 31	IP > 31	IP ≤ 31	IP > 31	IP ≤ 31	IP > 31
NT06 & MTZ1	Size per phase	1b 60 x 5	1b 60 x 5	1b 60 x 5	1b 60 x 5	1b 60 x 5	1b 60 x 5	1b 60 x 5	1b 60 x 5	1b 60 x 5	1b 60 x 5	1b 60 x 5	■
	I (A)	630	630	630	630	630	630	630	630	630	630	630	
NT08 & MTZ1	Size per phase	1b 80 x 5	1b 80 x 5	1b 80 x 5	1b 80 x 5	1b 80 x 5	1b 80 x 5	1b 80 x 5	1b 80 x 5	1b 80 x 5	1b 80 x 5	1b 80 x 5	■
	I (A)	800	800	800	800	800	800	800	800	800	800	800	
NT10 & MTZ1	Size per phase	2b 50 x 5	2b 50 x 5	2b 50 x 5	2b 50 x 5	2b 50 x 5	2b 50 x 5	2b 50 x 5	2b 50 x 5	2b 50 x 5	2b 50 x 5	2b 50 x 5	■
	I (A)	1000	1000	1000	1000	1000	1000	1000	1000	1000	960	1000	
NT12 & MTZ1	Size per phase	2b 60 x 5	2b 60 x 5	2b 60 x 5	2b 60 x 5	2b 60 x 5	2b 60 x 5	2b 60 x 5	2b 60 x 5	2b 60 x 5	2b 60 x 5	2b 60 x 5	■
	I (A)	1250	1250	1250	1250	1250	1230	1250	1180	1230	1130	1180	
NT16 & MTZ1	Size per phase	2b 80 x 5	2b 80 x 5	2b 80 x 5	2b 80 x 5	2b 80 x 5	2b 80 x 5	2b 80 x 5	2b 80 x 5	2b 80 x 5	2b 80 x 5	2b 80 x 5	■
	I (A)	1560	1430	1520	1430	1480	1380	1430	1330	1380	1280	1330	

■ Connection impossible due to the operating-temperature limits of the devices installed in the switchboard.

(1) Make the neutral connection with two bars, 50 x 5 mm.

Note: the values indicated above have been validated for Prisma P switchboards.