

Altivar[®] 61 / 71

User Manual
30072-452-35
Retain for future use

EtherNet/IP Card

VW3A3316

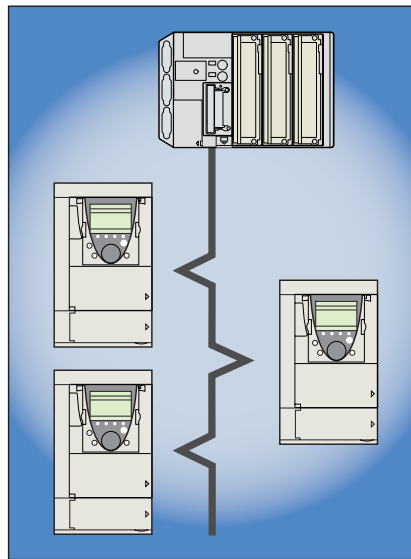

Table of Contents

1. Important Information	4
2. Before you begin	5
3. Documentation	6
4. Introduction	7
4. 1. Presentation	7
4. 2. Notation	7
5. Hardware setup	8
5. 1. Receipt	8
5. 2. Hardware description	8
5. 3. Installing the card in the drive	8
6. Connecting to the EtherNet/IP network	9
6. 1. Card RJ45 connector pinout	9
6. 2. Example of connection to an EtherNet/IP network	9
7. Using the HMI with the EtherNet/IP card	10
7. 1. Access to EtherNet/IP menu via graphic display terminal	10
7. 2. Access to EtherNet/IP menu via the integrated display terminal	10
7. 3. Ethernet/IP configuration with the HMI	11
7. 4. Detail of the configured parameters	12
7. 5. Assemblies and scanner configuration	12
8. Configuration of the assemblies	13
8. 1. Configuration of the assemblies: overview	13
8. 2. Configuration of the assembly (100,101) Telemecanique native profile	14
8. 3. Configuration of the assembly (103,104) Allen-Bradley® profile	15
8. 4. Configuring the communication scanner	16
8. 5. Configuring the control	17
9. Fault management	22
9. 1. Fault management	22
9. 2. Status of the LEDs	23
10. Configuration of monitored parameters	24
11. Web server	25
11. 1. Opening the Altivar home page	25
11. 2. Web pages structure	25
11. 3. Drive	26
11. 4. Network setup	29
11. 5. Diagnostics	32
12. Integration in RSLogix	34
12. 1. Principle	34
12. 2. Procedure	34
12. 3. Registering the EDS file in RSlogix	41
13. CIP objects	44
13. 1. Supported object classes	44
13. 2. Identity object	44
13. 3. Message router object	45
13. 4. Ethernet Link object	47
13. 5. TCP/IP Interface object	50
13. 6. Connection object manager	52
13. 7. Motor data object	53
13. 8. Control supervisor object	54
13. 9. AC/DC Drive Object	56
13. 10. Assembly object	57
13. 11. Application objects	58
14. Explicit Messaging	60
15. Device profiles	61
16. Configuring an ATV71/61 in replacement of a Powerflex® drive	70

1. Important Information

NOTICE

Read these instructions carefully, and look at the equipment to become familiar with the device before trying to install, operate, or maintain it. The following special messages may appear throughout this documentation or on the equipment to warn of potential hazards or to call attention to information that clarifies or simplifies a procedure.



The addition of this symbol to a Danger or Warning safety label indicates that an electrical hazard exists, which will result in personal injury if the instruction are not followed.



This is the safety alert symbol. It is used to alert you to potential personal injury hazards. Obey all safety messages that follow this symbol to avoid possible injury or death.

DANGER

DANGER indicates an imminently hazardous situation, which, if not avoided, **will result** in death, serious injury, or equipment damage.

WARNING

Warning indicates a potentially hazardous situation, which, if not avoided, **can result** in death, serious injury, or equipment damage.

CAUTION

CAUTION indicates a potentially hazardous situation, which, if not avoided, **can result** in injury or equipment damage.

TERMINOLOGY NOTE:

As used in this manual, the terms fault and error are defined as follows:

Fault: An abnormal condition that may cause a functional unit to lose its capability to perform a required function.

Error: A discrepancy between a computed, observed, or measured value or condition and the true, specified, or theoretically correct value or condition.

PLEASE NOTE:

Electrical equipment should be serviced only by qualified personnel. No responsibility is assumed by Schneider Electric for any consequences arising out of the use of this material. This document is not intended as an instruction manual for untrained persons.
© 2007 Schneider Electric. All Rights Reserved.

2. Before you begin

Read and understand these instructions before performing any procedure with this drive controller.

DANGER

HAZARD OF ELECTRIC SHOCK, EXPLOSION, OR ARC FLASH

- Read and understand this manual before installing or operating the Altivar 61 (ATV61) or Altivar 71 (ATV71) drive controller. Installation, adjustment, repair, and maintenance must be performed by qualified personnel.
- The user is responsible for compliance with all international and national electrical code requirements with respect to grounding of all equipment.
- Many parts of this drive controller, including the printed circuit boards, operate at the line voltage. DO NOT TOUCH. Use only electrically insulated tools.
- DO NOT touch unshielded components or terminal strip screw connections with voltage present.
- DO NOT short across terminals PA/+ and PC/- or across the DC bus capacitors.
- Before servicing the drive controller
 - Disconnect all power, including external control power that may be present.
 - Place a "DO NOT TURN ON" label on all power disconnects.
 - Lock all power disconnects in the open position.
 - WAIT 15 MINUTES to allow the DC bus capacitors to discharge. Then follow the DC bus voltage measurement procedure given in the Installation Manual to verify that the DC voltage is less than 45 V. The drive LED is not an indicator of the absence of DC bus voltage.
- Install and close all covers before applying power or starting and stopping the drive controller.

Failure to follow these instructions will result in death or serious injury.

WARNING

DAMAGED DRIVE CONTROLLER OR DRIVE ACCESSORY—UNINTENDED EQUIPMENT OPERATION

Do not install or operate any drive controller or drive accessory that appears damaged. The relays, inputs, or outputs of a damaged drive controller may not operate in a normal manner, leading to unintended equipment operation.

Failure to follow this instruction can result in death, serious injury, or equipment damage.

WARNING

LOSS OF CONTROL

- The designer of any control scheme must consider the potential failure modes of control paths and, for certain critical control functions, provide a means to achieve a safe state during and after a path failure. Examples of critical control functions are emergency stop and overtravel stop.
- Separate or redundant control paths must be provided for critical control functions.
- System control paths may include communication links. Consideration must be given to the implications of unanticipated transmission delays or failures of the link.*
- Each implementation of an Altivar 71 Modbus TCP/IP EtherNet/IP card must be individually and thoroughly tested for proper operation before being placed into service.

Failure to follow this instruction can result in death, serious injury, or equipment damage.

* For additional information, refer to NEMA ICS 1.1 (latest edition), "Safety Guidelines for the Application, Installation, and Maintenance of Solid State Control" and to NEMA ICS 7.1 (latest edition), "Safety Standards for Construction and Guide for Selection, Installation and Operation of Adjustable-Speed Drive Systems."

3. Documentation

The following Altivar 61 and Altivar 71 technical documents are available on the Web site www.us.Telemecanique.com and on the CD ROM delivered with each drive controller.

■ Installation Manual

This manual describes:

- How to assemble the drive controller
- How to connect the drive controller

■ Programming Manual

This manual describes:

- The drive controller functions
- The drive controller parameters
- How to use the drive display terminal (integrated display terminal and graphic display terminal)

Installation and Programming Manuals

Drive Family	Range (hp)	Installation Manual Module No.	Programming Manual Module No.
ATV61	0.5–100	1760643 (atv61s_installation_manual)	1760649 (atv61_programming_manual)
	75–800	1760655 (atv61e_installation_manual)	
ATV71	0.5–100	1755843 (atv71s_installation_manual)	1755855 (atv71_programming_manual)
	75–700	1755849 (atv71e_installation_manual)	

4. Introduction

4. 1. Presentation

The EtherNet/IP card (catalog number VW3A3316) is used to connect an Altivar 71 (ATV71) or an Altivar 61 (ATV61) drive controller to an Ethernet network using EtherNet/IP protocol.

IMPORTANT: This communication option card is supported by Altivar 61 firmware version V1.5 IE 13 and higher, and is only supported by Altivar 71 firmware version V1.6 IE 19 and above. Specific versions of the Altivar 71 firmware are not supported.

The VW3A3316 card is equipped with two shielded RJ45 EtherNet/IP connectors.

Accessories for connecting the drive controller to the EtherNet/IP network must be ordered separately.

The data exchanges permit the following drive controller functionality:

- Configuration
- Adjustment
- Control
- Monitoring
- Diagnostics

The standard web server (English only) provides access to the following pages:

- Altivar Viewer
- Data Viewer
- EtherNet/IP
- Security

The graphic display terminal or the integrated display terminal can be used to access numerous functions for communication diagnostics.

4. 2. Notation

The following notation is used in this manual:

Drive terminal displays

The graphic display terminal menus are shown in square brackets.

Example: [1.9 COMMUNICATION].

The integrated 7-segment display terminal menus are shown in round brackets.

Example: (L 0 0 -).

The parameter names displayed on the graphic display terminal are shown in square brackets.

Example: [Fallback speed].

The parameter codes displayed on the integrated 7-segment display terminal are shown in round brackets.

Example: (L F F).

Formats

Hexadecimal values are written as follows: 16#

Binary values are written as follows: 2#

5. Hardware setup

5. 1. Receipt

Upon receipt of the card:

- Ensure that the card catalog number marked on the label is the same as that on the packing list and the corresponding purchase order.
- Remove the option card from its packaging and check that it has not been damaged in transit.

⚠ CAUTION

STATIC SENSITIVE COMPONENTS

The EtherNet/IP card can be damaged by static electricity. Observe electrostatic precautions when handling and installing the card.

Failure to follow this instruction can result in equipment damage.

Observe the following precautions for handling static-sensitive components:

- Keep static-producing material such as plastic, upholstery, and carpeting out of the immediate work area.
- Store the EtherNet/IP card in its protective packaging when it is not installed in the drive controller.
- When handling the EtherNet/IP card, wear a conductive wrist strap connected to the card through a minimum of 1 megohm resistance.
- Avoid touching exposed conductors and component leads with skin or clothing.

5. 2. Hardware description

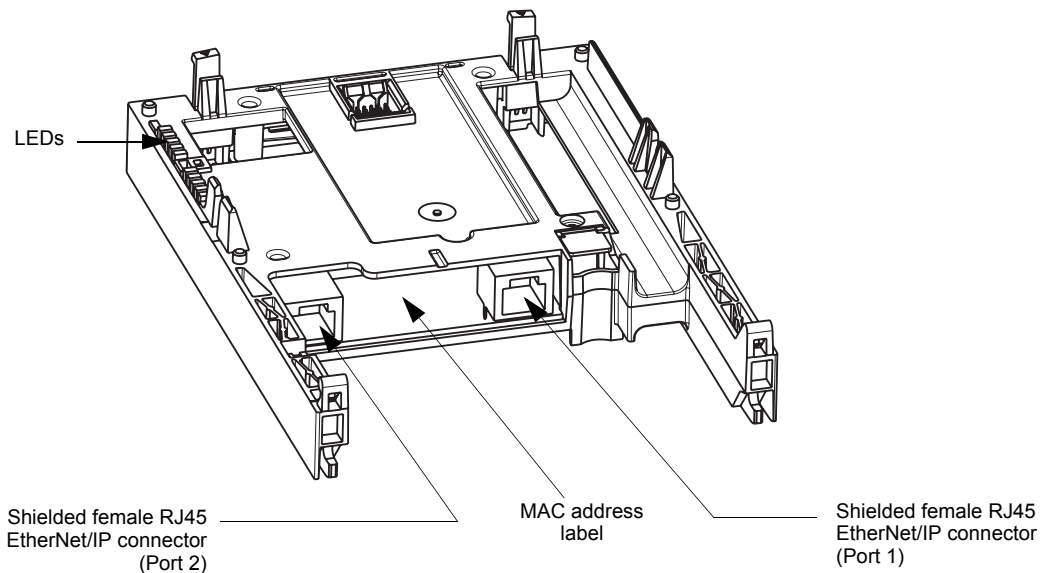

5. 3. Installing the card in the drive controller

See the Altivar 61 or Altivar 71 Installation Manual.

6. Connecting to the EtherNet/IP network

6. 1. Card RJ45 connector pinout

The EtherNet/IP card is equipped with two shielded RJ45 connectors. The shielding is connected to the drive controller ground. Use a shielded twisted pair (STP) EtherNet/IP cable.

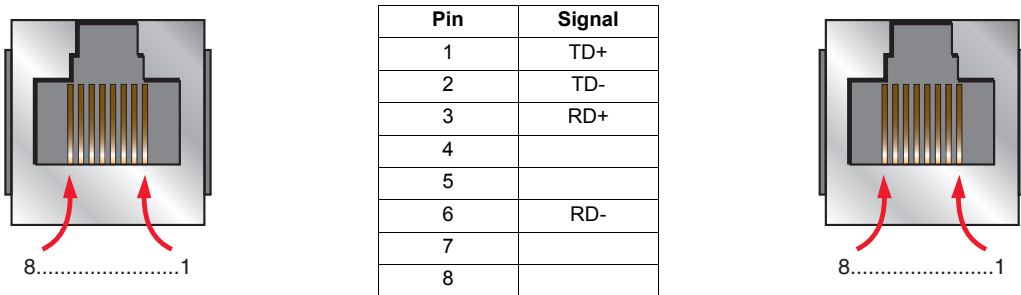

The transmission speed is detected automatically by the card (10 Mbps or 100 Mbps).

The card can operate in half duplex or full duplex mode, whether connected to a hub or a switch, and regardless of the transmission speed.

6. 2. Example of connection to an EtherNet/IP network

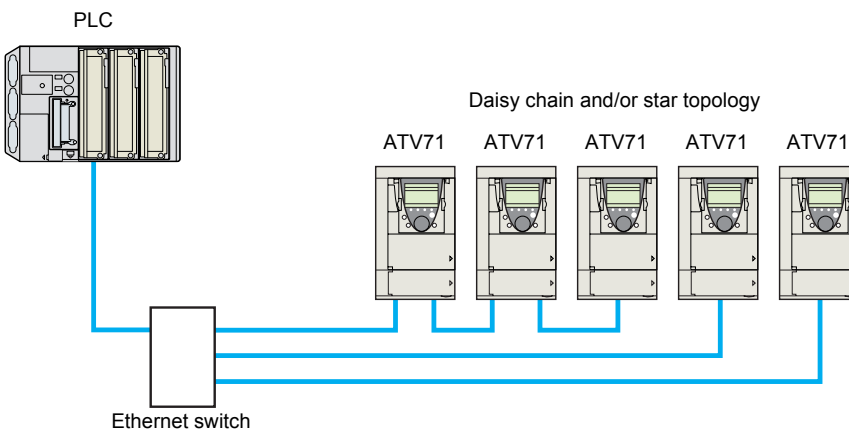

7. Using the HMI with the EtherNet/IP card

7.1. Access to EtherNet/IP menu via graphic display terminal

The [EtherNet/IP] submenu is used to configure and display the EtherNet/IP card parameters and can be accessed via the [1.9 - COMMUNICATION] menu.

This menu is only accessible in standard, advanced, and expert mode. In the [2 ACCESS LEVEL] (*LRC -*) menu, set the level to [expert] (*EP r*).

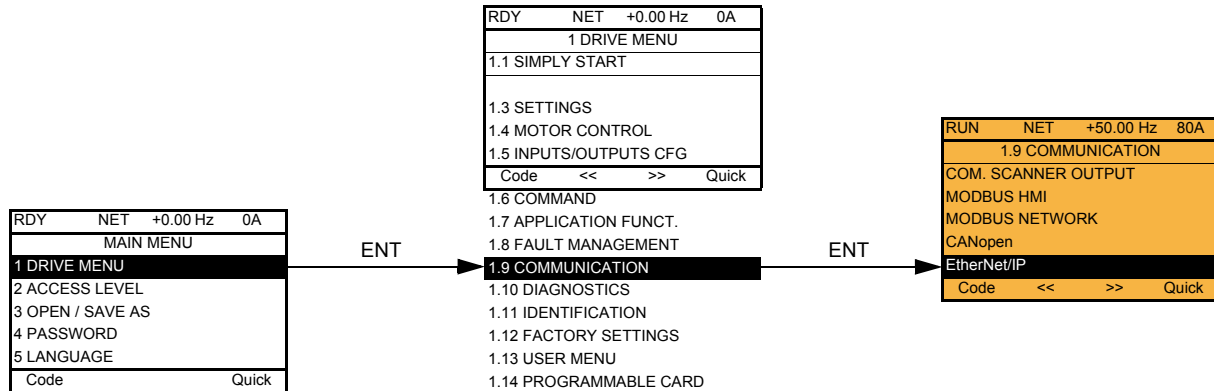

7.2. Access to EtherNet/IP menu via the integrated display terminal

The (*EEH -*) submenu is used to configure and display the EtherNet/IP card parameters. It can be accessed via the (*CON -*) menu.

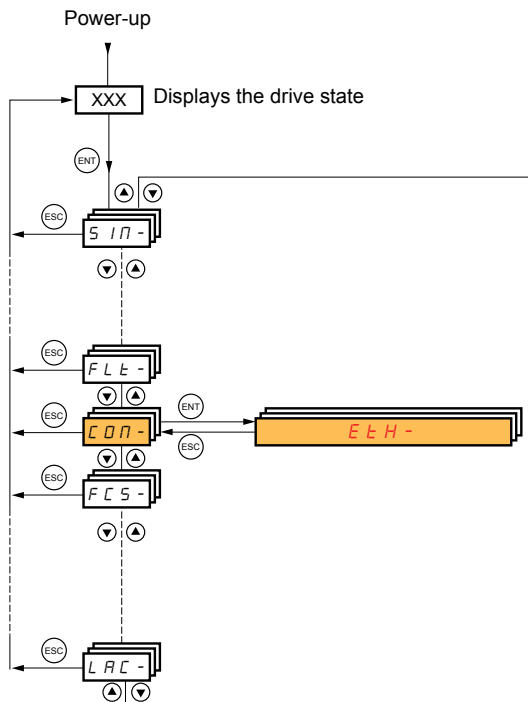

7. Using the HMI with the EtherNet/IP card

7.3. Ethernet/IP configuration with the HMI

The following table shows the parameters available on the Ethernet/IP configuration menu. These parameters can also be set from the web server or with the PowerSuite software. In the table, parameters which are not followed by their parameter code (between parenthesis) are not displayed on the 7 segment display of the drive controller.

[1.9 - COMMUNICATION] (C D N -) → menu [ETHIP] (E t h)

Parameter	Possible value	Terminal display
[DEVICE NAME] The device name is required if the card uses DHCP to obtain its IP Address.	16 characters	[ABC...]
[Rate Setting] (r d 5) Use this parameter to set the transmission speed and the transmission mode of the card.	0: Autodetect (default) 1: 10 Mbps Full 2: 10 Mbps Half 3: 100 Mbps Full 4: 100 Mbps Half (do not use)	[Auto] (A U E D) [10 Mbps full] (1 0 F) [10 Mbps half] (1 0 H) [100 Mbps full] (1 0 0 F) [100 Mbps half] (1 0 0 H)
[Actual Rate] (R r d) This field displays the baud rate and the transmission mode currently used by the communication card. (Display only)	0: Autodetect 1: 10 Mbps Full 2: 10 Mbps Half 3: 100 Mbps Full 4: 100 Mbps Half	[Auto] (A U E D) [10 Mbps full] (1 0 F) [10 Mbps half] (1 0 H) [100 Mbps full] (1 0 0 F) [100 Mbps half] (1 0 0 H)
[IP mode] (I P N) Use this parameter to select the IP address assignment method.	0: Manual 1: BOOTP 2: DHCP	[fixed] (F I X E D) [BOOTP] (b O O T P) [DHCP] (d H C P)
[IP card] (I P C -) (I P C 1) (I P C 2) (I P C 3) (I P C 4) IP address of the card	These fields can be edited when the IP mode is set to Fixed address.	[139.160.069.241] (1 3 9) (1 6 0) (0 6 9) (2 4 1)
[IP Mask] (I P N -) (I P N 1) (I P N 2) (I P N 3) (I P N 4) Subnet mask	These fields can be edited when the IP mode is set to Fixed address.	[255.255.254.0] (2 5 5) (2 5 5) (2 5 4) (0)
[IP Gate] (I P G -) (I P G 1) (I P G 2) (I P G 3) (I P G 4) Default gateway IP address	These fields can be edited when the IP mode is set to Fixed address.	[0.0.0.0] (0) (0) (0) (0)
<ul style="list-style-type: none"> • If the address has been given by a BOOTP or a DHCP server, these fields are read only. • After dynamic addressing by a BOOTP or DHCP server, the new address value is displayed. 		
[Services] (E E) Enables web server and e-mail functions. This parameter can only be configured from the web server or PowerSuite software. This parameter is significant at the bit level. Bit 0 and bit 1 are used to set the values shown in this table. The other bits are reserved.	0: Web Server and Email functions disabled 1: Web Server activated 2: Email function activated 3: Web server and Email functions activated	0 1 2 3
[MAC @] MAC address display	[00-80-F4-XX-XX-XX]	[00-80-F4-XX-XX-XX]

7. Using the HMI with the EtherNet/IP card

7. 4. Detail of the configured parameters

■ IP address

Assigning IP addresses

The drive controller needs 3 IP addresses:

- The drive IP address
- The subnet mask
- The gateway IP address (not always required)

According to the setting of the IP Mode parameter (see the table below), the IP addresses can be provided by:

- A BOOTP server (correspondence between the MAC address and the IP addresses).
- Or a DHCP server (correspondence between Device Name [DEVICE NAME] and the IP addresses).

IP Mode value	Comments
IP mode = 0	The card uses the address defined in IPC1, IPC2, IPC3, IPC4
IP mode = 1	The card receives its address from a BOOTP server
IP mode = 2	The card receives its address from a DHCP server
And Device name contains a valid name.	

IMPORTANT: The IP Mode parameter may be modified according to the **configuration control attribute** of the **TCP/IP interface object** (CIP standard). See page [50](#).

7. 5. Assemblies and scanner configuration

The assemblies are chosen at the master controller level. See chapter 12, Integration in RSlogix, beginning on page 34.

For the 4 ODVA set of assemblies (20, 21, 22, 23, 70, 71, 72, 73), no further configuration is required at the communication scanner level.

For the Telemecanique assemblies (100, 101) and Allen-Bradley® assemblies (103, 104) you must:

- Configure the size of the assembly at the drive controller level, and
- Define the mapping of the additional parameters.

8. Configuration of the assemblies

8. 1. Configuration of the assemblies: overview

VW3A3316 EtherNet/IP communication card
Features overview

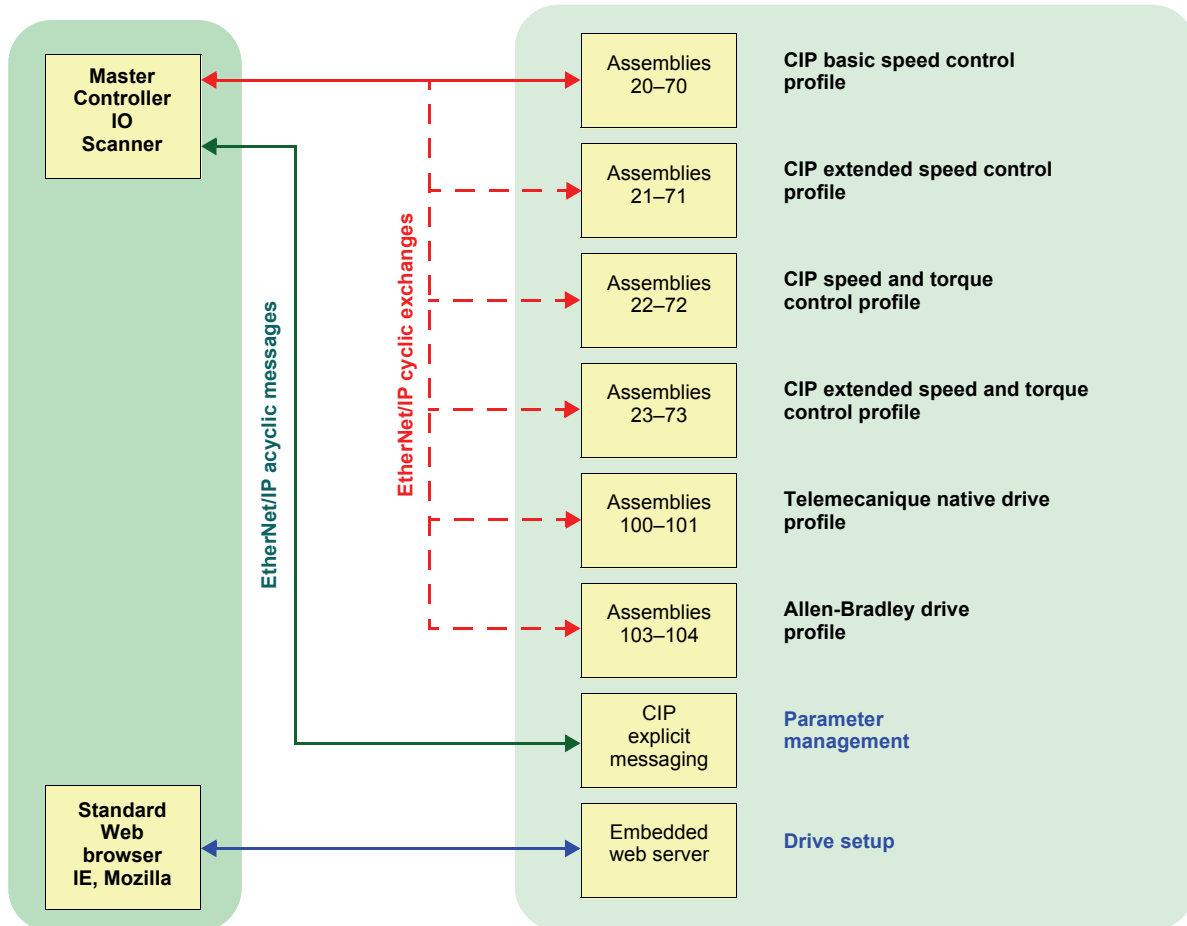

8. Configuration of the assemblies

8.2. Configuration of assemblies 100–101, Telemecanique native profile

The size of the assembly is fixed and is equal to 8 words.

The variables exchanged by assemblies 100 and 101 are mapped with the communication scanner. See page 16.

The addresses are defined with NCAx and NMAx can be configured with the graphic keypad:

For assembly 100, go to the [1.9- COMMUNICATION] (C D N -) menu, [COM.SCANNER OUTPUT] (D C S -) submenu.

For assembly 101, go to the [1.9- COMMUNICATION] (C D N -) menu, [COM.SCANNER INPUT] (I C S -) submenu.

See menu [1.2 MONITORING] > COMMUNICATION MAP for monitoring the communication scanner.

See also “Configuring the communication scanner” on page 16.

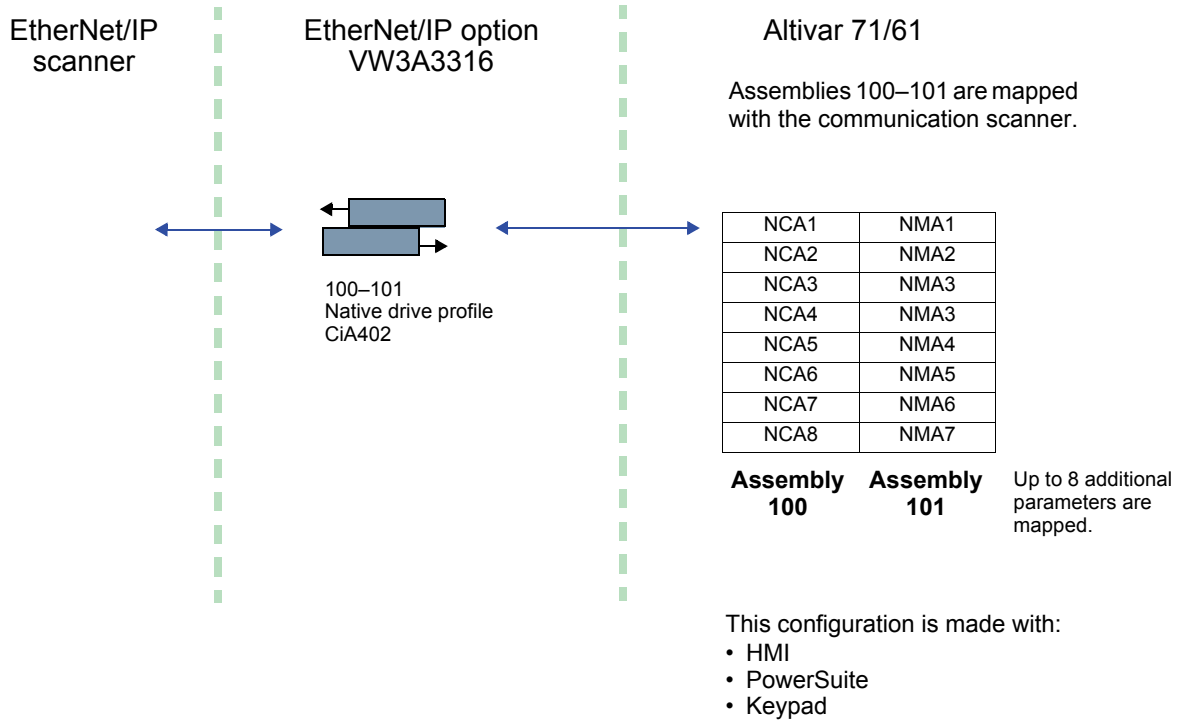

The following is an example of the configuration of assemblies 100–101 from RSLogix software:

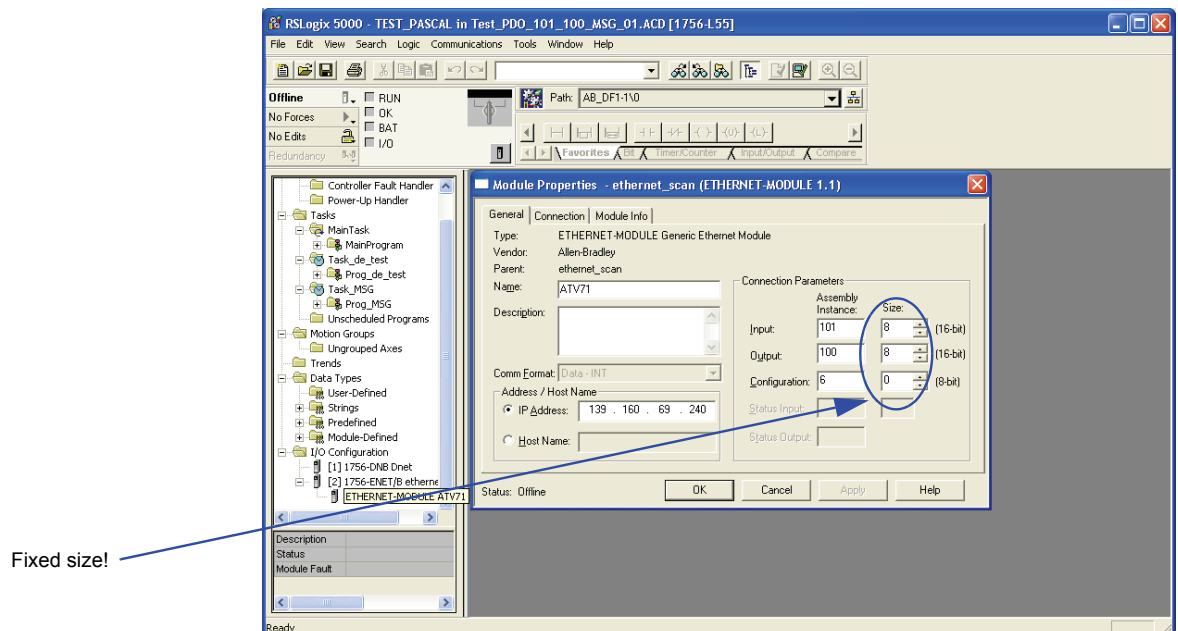

8. Configuration of the assemblies

8.3. Configuration of assemblies 103–104, Allen-Bradley® profile

The size of the assembly is selectable from 2 to 10 words.

The first two words of the input assembly are fixed as Control word and Speed setpoint.

The first four words of the output assembly are two-pad words and fixed as Status word and Actual speed.

IMPORTANT: NCA1 and NCA2 are already configured by the default settings of the drive controller. It is important when configuring this assembly to manually remove the default assignment of NCA1 and NCA2 by setting NCA1 and NCA2 to a null address or by configuring these two addresses to other required parameters of the drive controller.

This will avoid a conflict between NCA1 and the control word of the profile (located in the first word of assembly 103).

The configuration of the addresses defined with NCAx and NMAx can be made with the graphic keypad:

For assembly 103, go to the [1.9- COMMUNICATION] (C D N -) menu, [COM.SCANNER OUTPUT] (D C 5 -) submenu.

For assembly 104, go to the [1.9- COMMUNICATION] (C D N -) menu, [COM.SCANNER INPUT] (I C 5 -) submenu.

See menu [1.2 MONITORING] > COMMUNICATION MAP for monitoring the communication scanner.

See also “Configuring the communication scanner” on page 16

The mapping of the other parameters is made with the EtherNet/IP scanner:

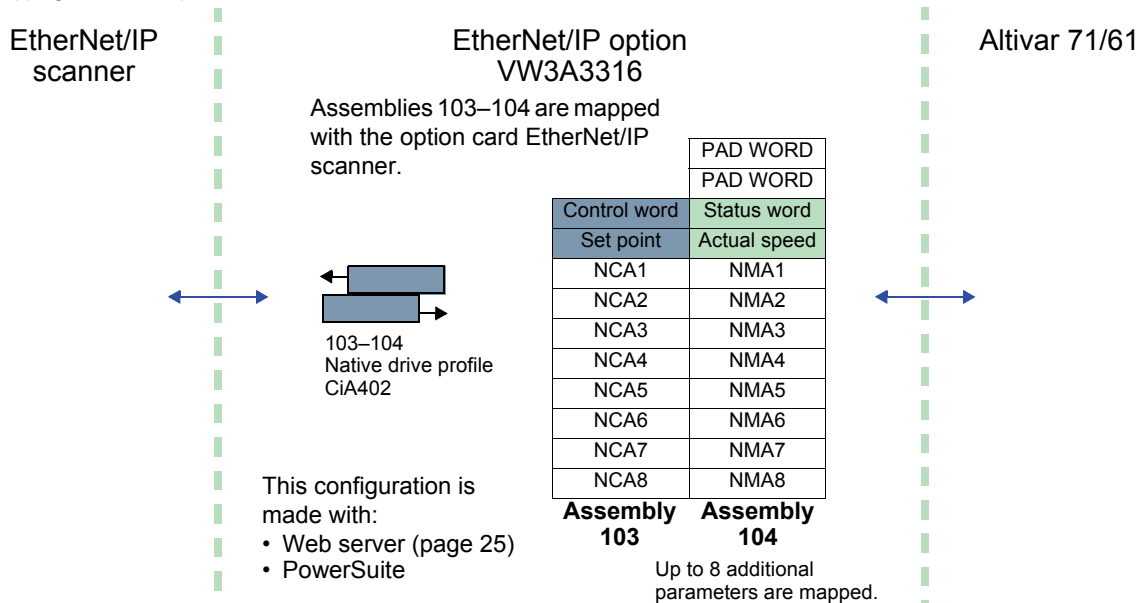

The following is an example of the configuration of assemblies 103–104 from RSLogix software:

The sizes indicated must be adjusted according to the settings defined with the EtherNet/IP scanner setup (via the web server or PowerSuite software).

Note:

- The size of the assembly cannot be modified dynamically; such a change requires cycling the power.
- Given that assembly 103–104 uses NCAx and NMAx, the configuration edited with the web server or PowerSuite software is also applied to the drive controller communication scanner of the drive controller (like assemblies 100–101).

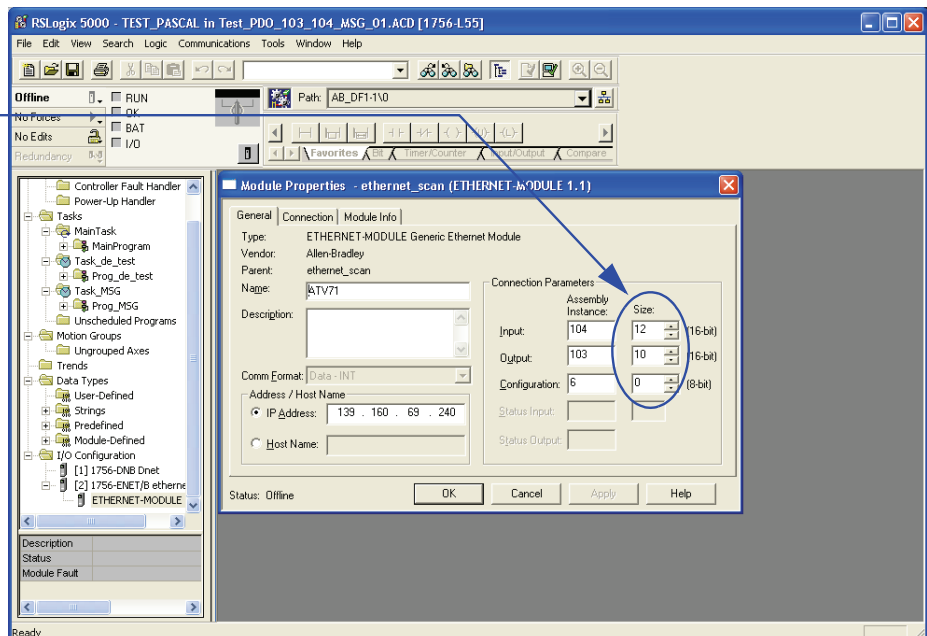

8. Configuration of the assemblies

8. 4. Configuring the communication scanner

You need to read this chapter only if you use assemblies 100 or 101.

The variables exchanged by output assembly 100 and input assembly 101 are selected by configuring the communication scanner.

The 8 output variables of assembly 100 are assigned by means of the 8 parameters at [Scan. Out address] (n C R ●). They are configured using the graphic display terminal via the [1.9 - COMMUNICATION] (L D P -) menu, [COM. SCANNER OUTPUT] (D C 5 -) submenu.

The 8 input variables of assembly 101 are assigned by means of the 8 parameters at [Scan. In address] (n P R ●). They are configured using the graphic display terminal via the [1.9 - COMMUNICATION] (L D P -) menu, [COM. SCANNER INPUT] (I C 5 -) submenu.

Enter the logic address of the parameter (see the Communication parameters manual).

If a parameter [Scan. Out address] (n C R ●) or [Scan. In address] (n P R ●) is equal to zero, the corresponding period variable is not used by the drive controller.

The 8 assignment parameters are described in the tables below:

Parameter name	Output assembly 100	Default assignment
[Scan. Out1 address] (n C R 1)		NCA1 = 8501 (Control word)
[Scan. Out2 address] (n C R 2)		NCA2 = 8602 (Speed reference in rpm)
[Scan. Out3 address] (n C R 3)		NCA3 = not used
[Scan. Out4 address] (n C R 4)		NCA4 = not used
[Scan. Out5 address] (n C R 5)		NCA5 = not used
[Scan. Out6 address] (n C R 6)		NCA6 = not used
[Scan. Out7 address] (n C R 7)		NCA7 = not used
[Scan. Out8 address] (n C R 8)		NCA8 = not used

Parameter name	Input assembly 101	Default assignment
[Scan. In1 address] (n P R 1)		NMA1 = 3201 (Status)
[Scan. In2 address] (n P R 2)		NMA2 = 8604 (Output speed in rpm)
[Scan. In3 address] (n P R 3)		NMA3 = not used
[Scan. In4 address] (n P R 4)		NMA4 = not used
[Scan. In5 address] (n P R 5)		NMA5 = not used
[Scan. In6 address] (n P R 6)		NMA6 = not used
[Scan. In7 address] (n P R 7)		NMA7 = not used
[Scan. In8 address] (n P R 8)		NMA8 = not used

The following is an example of configuration via the graphic display terminal:

RDY	NET	+0.00Hz	0A
COM. SCANNER INPUT			<input type="checkbox"/>
Scan. In1 address	:		3204
Scan. In2 address	:		3206
Scan. In3 address	:		0
Scan. In4 address	:		0
Scan. In5 address	:		0
Code		Quick	<input checked="" type="checkbox"/>
Scan. In6 address	:		0
Scan. In7 address	:		0
Scan. In8 address	:		0

RDY	NET	+0.00Hz	0A
COM. SCANNER OUTPUT			<input type="checkbox"/>
Scan. Out1 address	:		9001
Scan. Out2 address	:		9002
Scan. Out3 address	:		0
Scan. Out4 address	:		0
Scan. Out5 address	:		0
Code		Quick	<input checked="" type="checkbox"/>
Scan. Out6 address	:		0
Scan. Out7 address	:		0
Scan. Out8 address	:		0

Note:

Modifications to parameters [Scan. Out address] (n C R ●) or [Scan. In address] (n P R ●) must be made with the motor stopped. The master PLC program must be updated to take account of this modification.

8. Configuration of the assemblies

8. 5. Configuring the control

■ Principle

By configuring the control, it is possible to select the channel from which the drive controller receives its commands and setpoint, either permanently or by a switching command.

Numerous configurations are possible. For more information, refer to the Programming Manual and Communication Parameters Manual. The following are some of the possible configurations.

□ Control with communication scanner

If the default assemblies (100, 101) are selected, the modes and profiles of the Altivar 71 drive controller are unrestricted.

It is possible to use the following profiles and modes of the drive controller:

- I/O profile
- Drivecom profiles with separate or non separate modes

I/O profile allows simple operation of the drive controller. Bit 0 of cmd word is the run command. The other bits can be configured in the same way as the drive's logic inputs.

Drivecom requires that specific steps be followed to operate the drive controller. See the Communications Parameters and Programming guides for additional details.

By configuring the communication scanner, it is possible to assign any relevant parameter of the drive controller to the 4 input and 4 output variables of the assemblies.

The input / output interface with the PLC can be customized depending on the application.

Use the communication scanner to interface with a Controller Inside card.

□ Control according to ODVA AC drive profile

The ODVA AC drive profile is activated when one of the following assemblies is selected:

- 20: Basic speed control output
- 21: Extended speed control output
- 22: Speed and torque control output
- 23: Extended speed and torque control output
- 70: Basic speed control input
- 71: Extended speed control input
- 72: Speed and torque control input
- 73: Extended speed and torque control input

The advantage of using the ODVA drive profile standard is the interchangeability with other brands.

The drive controller must be configured in the Drivecom profile with separate mode.

The EtherNet/IP card translates the commands, behavior, and monitoring information from the ODVA profile (on the network) to the Drivecom profile (in the drive controller).

□ Control according to Allen-Bradley® drive profile

The Allen-Bradley drive profile is activated when one of the following assemblies is selected:

- 103: Allen-Bradley drive output
- 104: Allen-Bradley drive input

If you need to replace Allen-Bradley drive controllers in an existing application, using this profile is a good way to minimize modification.

The drive controller must be configured in the Drivecom profile with Separate mode.

The EtherNet/IP card translates the commands, behavior, and monitoring information from the Allen-Bradley drive profile (on the network) to the Drivecom profile (in the drive controller).

8. Configuration of the assemblies

■ Available configurations

□ If you use the communication scanner:

- 100: Communication scanner output
- 101: Communication scanner input. There are no restrictions in the configuration of the control.

The examples beginning on page 19 are only possible if you use the communication scanner.

□ If you use the ODVA AC drive profile or the Allen-Bradley® drive profile, the assemblies are defined as follows:

- 20: Basic speed control output
- 21: Extended speed control output
- 22: Speed and torque control output
- 23: Extended speed and torque control output
- 70: Basic speed control input
- 71: Extended speed control input
- 72: Speed and torque control input
- 73: Extended speed and torque control input
- 103: Allen-Bradley drive output
- 104: Allen-Bradley drive input

Parameter	Permitted value	Comment
Profile	Drivecom profile separate	The run commands are in Drivecom profile, the command and the reference can come from different channels.
Setpoint 1 configuration	Network card	Setpoint 1 comes from EtherNet/IP.
Setpoint 1B configuration	Terminals	Setpoint 2 comes from terminals (AI1 or AI2).
Setpoint 2 configuration	Terminals	Setpoint 2 comes from terminals (AI1 or AI2).
Command 1 configuration	Network card	Command 1 comes from EtherNet/IP.
Command 2 configuration	Terminals	Command 2 comes from terminals.
Setpoint switching	Network card bit 12	Bit 12 of the control word switches the setpoint (1 ↔ 1B or 1 ↔ 2).
Command switching	Network card bit 13	Bit 13 of the control word switches the command.

Configuration via the graphic display terminal or the integrated display terminal:

Case 1: Setpoint 1B is connected to the functions (Summing, PID, etc.) which remain active even after switching.

Menu	Parameter	Permitted value
[1.6 - COMMAND] (CLL -)	[Profile] (CHF)	[Separate] (SEP)
	[Ref.1 channel] (Fr1)	[Com. card] (NEK)
	[Ref.1B channel] (Fr1b)	[Ref. AI1] (R11) or [Ref. AI2] (R12)
	[Cmd channel 1] (Cd1)	[Com. card] (NEK)
	[Cmd channel 2] (Cd2)	[Terminals] (TER)
[1.7 APPLICATION FUNCT.] (FUN -) [REFERENCE SWITCH.]	[Cmd switching] (CES)	[C312] (E312)
	[Ref 1B switching] (rCb)	[C313] (E313)

Case 2: Setpoint 2 is directly connected to the drive controller's reference limit. If switching is performed, the functions that affect the reference (summing, PID, etc.) are inhibited.

Menu	Parameter	Permitted value
[1.6 - COMMAND] (CLL -) [1.7 APPLICATION FUNCT.] (FUN -) [REFERENCE SWITCH.]	[Profile] (CHF)	[Separate] (SEP)
	[Ref.1 channel] (Fr1)	[Com. card] (NEK)
	[Ref.2 channel] (Fr2)	[Ref. AI1] (R11) or [Ref. AI2] (R12)
	[Cmd channel 1] (Cd1)	[Com. card] (NEK)
	[Cmd channel 2] (Cd2)	[Terminals] (TER)
	[Cmd switching] (CES)	[C312] (E312)
	[Ref. 2 switching] (rFL)	[C313] (E313)

Note: It is not possible to configure the display terminal as a channel.

To switch to the display terminal, use the force local function and assign parameter [Forced local Ref.] to [HMI] (LLC).

8. Configuration of the assemblies

■ Control via EtherNet/IP in I/O profile

Note: This configuration can only be used if the communication scanner assemblies (100 and 101) are selected.

The command and the setpoint come from EtherNet/IP.
Control is from the I/O profile.

Configure the following parameters:

Parameter	Value	Comment
Profile	I/O profile	The run command comes from bit 0 of the command word.
Setpoint 1 configuration	Network card	The setpoint comes from EtherNet/IP.
Command 1 configuration	Network card	The command comes from EtherNet/IP.

Configuration via the graphic display terminal or the integrated display terminal:

Menu	Parameter	Value
[1.6 - COMMAND] (EEL -)	[Profile] (EHCF)	[I/O profile] (ID)
	[Ref.1 channel] (Frl)	[Com. card] (nEt)
	[Cmd channel 1] (Ed1)	[Com. opt card] (nEt)

■ Control via EtherNet/IP or via the terminals in I/O profile

Note: This configuration can only be used if the communication scanner assemblies (100 and 101) are selected.

The command and the setpoint both come from EtherNet/IP or the terminals. Input LI5 at the terminals is used to switch between EtherNet/IP and the terminals.
Control is from the I/O profile.

Configure the following parameters:

Parameter	Value	Comment
Profile	I/O profile	The run command comes from bit 0 of the control word.
Setpoint 1 configuration	Network card	Setpoint 1 comes from EtherNet/IP.
Setpoint 1B configuration	Analog input 1 on the terminals	Setpoint 1B comes from input AI1 on the terminals.
Setpoint switching	Input LI5	Input LI5 switches the setpoint (1 ↔ 1B).
Command 1 configuration	Network card	Command 1 comes from EtherNet/IP.
Command 2 configuration	Terminals	Command 2 comes from the terminals.
Command switching	Input LI5	Input LI5 switches the command.

Note: Setpoint 1B is connected to the functions (Summing, PID, etc.) which remain active even after switching.

Configuration via the graphic display terminal or the integrated display terminal:

Menu	Parameter	Value
[1.6 - COMMAND] (EEL -)	[Profile] (EHCF)	[I/O profile] (ID)
	[Ref.1 chan] (Frl)	[Com. card] (nEt)
	[Cmd channel 1] (Ed1)	[Com. card] (nEt)
	[Cmd channel 2] (Ed2)	[Terminals] (EEr)
	[Cmd switching] (EES)	[LI5] (LI5)
[1.7 APPLICATION FUNCT.] (FUN -) [REFERENCE SWITCH.]	[Ref.1B chan] (Frlb)	[AI1 ref.] (RII)
	[Ref 1B switching] (rEb)	[LI5] (LI5)

8. Configuration of the assemblies

■ Control via EtherNet/IP in Drivecom profile

Note: This configuration can only be used if the communication scanner assemblies (100 and 101) are selected.

The command and the setpoint come from EtherNet/IP.

Configure the following parameters:

Parameter	Value	Comment
Profile	Separate Drivecom profile	The run commands are from the Drivecom profile. The command and the setpoint can come from different channels.
Setpoint 1 configuration	Network card	The setpoint comes from EtherNet/IP.
Command 1 configuration	Network card	Command 1 comes from EtherNet/IP.

Configuration via the graphic display terminal or the integrated display terminal:

Menu	Parameter	Value
[1.6 - COMMAND] (C t L -)	[Profile] (C H C F)	[Separate] (S E P)
	[Ref.1 chan] (F r 1)	[Com. card] (n E t)
	[Cmd channel 1] (C d 1)	[Com. card] (n E t)

■ Control via EtherNet/IP or the terminals in Drivecom profile

Note: This configuration can only be used if the communication scanner assemblies (100 and 101) are selected.

The command and the setpoint both come from EtherNet/IP or the terminals. Input LI5 is used to switch between EtherNet/IP and the terminals.

Configure the following parameters:

Parameter	Value	Comment
Profile	Separate Drivecom profile	The run commands come from the Drivecom profile. The command and the setpoint can come from different channels.
Setpoint 1 configuration	Network card	Setpoint 1 comes from EtherNet/IP.
Setpoint 2 configuration	Analog input 1 on the terminals	Setpoint 2 comes from input AI1 on the terminals.
Setpoint switching	Input LI5	Input LI5 switches the setpoint (1 ↔ 2) and the command.
Command 1 configuration	Network card	Command 1 comes from EtherNet/IP.
Command 2 configuration	Terminals	Command 2 comes from the terminals.
Command switching	Input LI5	Input LI5 switches the command.

Note: Setpoint 2 is directly connected to the drive controller reference limit. If switching is performed, the functions that affect the reference (summing, PID, etc.) are inhibited.

Configuration via the graphic display terminal or the integrated display terminal:

Menu	Parameter	Value
[1.6 - COMMAND] (C t L -)	[Profile] (C H C F)	[Separate] (S E P)
	[Ref.1 chan] (F r 1)	[Com. card] (n E t)
	[Ref.2 chan] (F r 2)	[AI1 ref.] (R I I)
	[Ref. 2 switching] (r F C)	[LI5] (L I 5)
	[Cmd channel 1] (C d 1)	[Com. card] (n E t)
	[Cmd channel 2] (C d 2)	[Terminals] (t E r)
	[Cmd switching] (C C S)	[LI5] (L I 5)

8. Configuration of the assemblies

■ Control in Drivecom profile via EtherNet/IP and setpoint switching at the terminals

Note: This configuration can only be used if the communication scanner assemblies (100 and 101) are selected.

The command comes from EtherNet/IP.

The setpoint comes either from EtherNet/IP or from the terminals. Input LI5 at the terminals is used to switch the setpoint between EtherNet/IP and the terminals.

Control comes from the Drivecom profile.

Configure the following parameters:

Parameter	Value	Comment
Profile	Separate Drivecom profile	The run commands come from the Drivecom profile. The command and the setpoint can come from different channels.
Setpoint 1 configuration	Network card	Setpoint 1 comes from EtherNet/IP.
Setpoint 1B configuration	Analog input 1 on the terminals	Setpoint 1B comes from input AI1 on the terminals.
Setpoint switching	Input LI5	Input LI5 switches the setpoint (1 ↔ 1B).
Command 1 configuration	Network card	Command 1 comes from EtherNet/IP.
Command switching	Channel 1	Channel 1 is the command channel.

Note: Setpoint 1B is connected to the functions (summing, PID, etc.) which remain active even after switching.

Configuration via the graphic display terminal or the integrated display terminal:

Menu	Parameter	Value
[1.6 - COMMAND] (C E L -)	[Profile] (C H C F)	[Separate] (S E P)
	[Ref.1 chan] (F r 1)	[Com. card] (n E E)
	[Cmd channel 1] (C d 1)	[Com. card] (n E E)
	[Cmd switching] (C C S)	[ch1 active] (C d 1)
[1.7 APPLICATION FUNCT.] (F U n -) [REFERENCE SWITCH.]	[Ref.1B chan] (F r 1 b)	[AI1 ref.] (R 1 1)
	[Ref 1B switching] (r C b)	[LI5] (L 1 5)

9. Fault management

9. 1. Fault management

An EtherNet/IP time out is triggered if the card does not receive any cyclic messages within a predefined time period. This time period is managed by the EtherNet/IP controller (not by the drive controller), and is configured in the Module Properties window. The duration of the time out is defined by the RPI (request packet intervals). See the figure below.

If the card is controlled by explicit messages (without periodic exchanges), there is no control of the communication time-out.

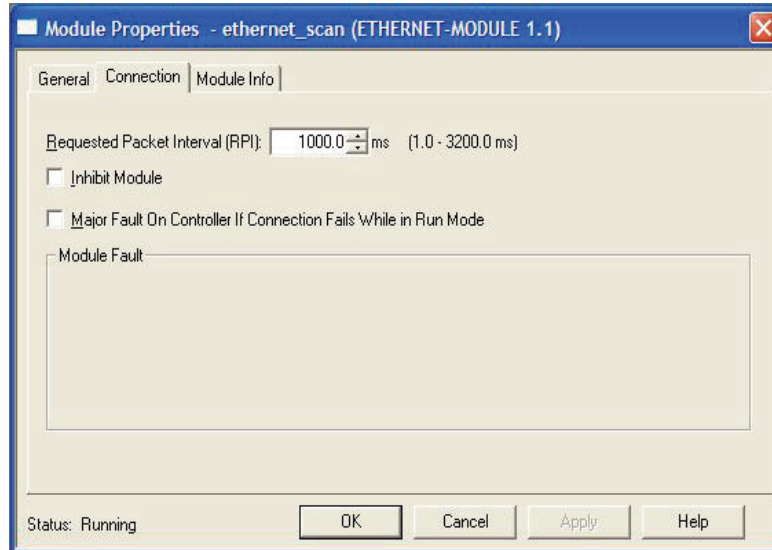

The **response** of the drive controller to a time out can be configured as shown below.

Configuration can be performed using the graphic display terminal or the integrated display terminal using the [\[Network fault mgt\] \(E L L\)](#) parameter in the [\[1.8 FAULT MANAGEMENT\] \(F L E -\)](#) menu, [\[COM. FAULT MANAGEMENT\] \(E L L -\)](#) submenu.

RDY	NET	+0.00Hz	0A
COM. FAULT MANAGEMENT			<input type="checkbox"/>
Network fault mgt	:	Freewheel	
CANopen fault mgt	:	Freewheel	
Modbus fault mgt	:	Freewheel	
	:		
	:		
Code		Quick	<input checked="" type="checkbox"/>

The values of the [\[Network fault mgt\] \(E L L\)](#) parameter which trigger a [\[COM. network\] \(E n F\)](#) fault to the drive are:

Value	Meaning
[Freewheel] (Y E S)	Freewheel stop (factory setting)
[Ramp stop] (r n P)	Stop on ramp
[Fast stop] (F S E)	Fast stop
[DC injection] (d E I)	DC injection stop

The values of the [\[Network fault mgt\] \(E L L\)](#) parameter which do not trigger a [\[COM. network\] \(E n F\)](#) fault to the drive are:

Value	Meaning
[Ignore] (n D)	Fault ignored
[Per STT] (S E E)	Stop according to configuration of [Type of stop] (S E E)
[Fallback spd] (L F F)	Switch to fallback speed, maintained as long as the fault is present and the run command is not disabled.
[Spd maint.] (r L S)	The drive controller maintains the speed at the time the fault occurred, as the fault persists and the run command has not been removed.

The fallback speed can be configured via the [\[Fallback spd\] \(L F F\)](#) parameter in the [\[1.8 FAULT MANAGEMENT\] \(F L E -\)](#) menu.

9. Fault management

9.2. Status of the LEDs

The VW3A3316 Ethernet/IP card features 5 LEDs, which are visible through the Altivar 61/71 drive controller cover.

1.1
1.2
1.3
1.4
1.5

2.1 Port 1 activity
2.2 Port 2 activity
2.3 Link status
2.4 NS "Network status"
2.5 MS "Module status"

The first two LEDs indicate the status of the two Ethernet ports.
The third LED indicates the IP link status.
The last two LEDs indicate EtherNet/IP and CIP communication status.

The following table defines the LED indications.

LED	Color/ state	Description
2.1	Off	No link
	Flashing Green/yellow	Power up testing
	Green ON	Link at 100 Mbps
	Yellow ON	Link at 10 Mbps
	Green BLINK	Activity at 100 Mbps
	Yellow BLINK	Activity at 10 Mbps
2.2	Off	No link
	Flashing Green/yellow	Power up testing
	Green ON	Link at 100 Mbps
	Yellow ON	Link at 10 Mbps
	Green BLINK	Activity at 100 Mbps
	Yellow BLINK	Activity at 10 Mbps
2.3	Off	Physical connections unplugged. No IP address obtained.
	Flashing Green/red	Power up testing
	Green On	At least one port is connected and an IP address has been obtained.
	Green flashing 3 times	Ports are unplugged, but the card has an IP address.
	Green flashing 4 times	Error: Duplicated IP address (1)
	Green flashing 5 times	The card is performing a BOOTP or DHCP sequence.
2.4 "NS"	Off	The device does not have an IP address or the power is off.
	Flashing Green/red	Power up testing
	Green On	The device has at least one established connection (even to the Message Router).
	Green flashing	The device has not established connections, but has obtained an IP address.
	Red flashing	One or more of the connections in which this device is the target has timed out. This indication stops only if the time out connections are reestablished or the device is reset.
	Red On	The device has detected that its IP address is already in use (1).
2.5 "MS"	Off	No power is supplied to the device
	Flashing Green/red	Power Up testing
	Green On	The device is operating correctly.
	Green flashing	The device has not been configured.
	Red flashing	The device has detected a recoverable minor fault.
	Red On	The device has detected a non-recoverable major fault (1).

(1) If duplicate IP addresses are detected, LED 2.3 flashes green 4 times, and LEDs 2.4 and 2.5 are on red.

10. Configuration of monitored parameters

It is possible to select up to 4 parameters for display on the [1.2 - MONITORING] menu of the graphic display terminal.

The selection is made via the [6 - MONITORING CONFIG.] menu, [6.3 - COM. MAP CONFIG.] submenu.

Each parameter in the range [Address 1 select.] to [Address 4 select.] is used to select the parameter logic address. Select an address of zero to disable the function.

In the example given here, the monitored words are:

- Parameter 1 = Motor current (LCR): logic address 3204; signed decimal format.
- Parameter 2 = Motor torque (OTR): logic address 3205; signed decimal format.
- Parameter 3 = Last fault occurred (LFT): logic address 7121; hexadecimal format.
- Disabled parameter: address 0; default format: hexadecimal format.

RDY	NET	+0.00Hz	0A
6.3 COM. MAP CONFIG.			<input type="checkbox"/>
Word 1 add. select.	:		3204
Format word 1	:		Signed
Word 2 add. select.	:		3205
Format word 2	:		Signed
Word 3 add. select.	:		7121
<input type="checkbox"/> Code		<input type="checkbox"/> Quick	<input checked="" type="checkbox"/>
Format word 33	:		Hex
Word 4 add. select.	:		0
Format word 4	:		Hex

One of the three display formats shown below can be assigned to each monitored word:

Format	Range	Terminal display
Hexadecimal	0000 to FFFF	[Hex]
Signed decimal	-32,767 to 32,767	[Signed]
Unsigned decimal	0 to 65,535	[Unsigned]

11. Web server

This chapter describes the function of the EtherNet/IP card's integrated web server. See page 11. The [SERVICES] parameter must be set to "1" to access the web server.

11. 1. Opening the Altivar home page

From your web browser, log in with the default http password. The passwords are USER for monitor and setup security level, and ADMIN for administrator level.



From the Altivar home page, you can access 4 main menus:

- Drive
- Network setup
- Network diagnostic
- Email

11. 2. Web pages structure

Each web page has the same structure. The main menus (Drive, Network setup, and Network diagnostic) have their own sub menus, which are displayed on the left side of web page.



The  toggle button shows or hides the left side menus.

11. Web server

11.3. Drive

■ Drive monitor

Device Reference	ATV71H075M3
Device Name	Not defined
Altivar State	RDY

FRH Freq. Ref.	Hz	0.0
RFR Output Freq.	Hz	0.0
OTR Output Torque	%	0.0
ULN Mains Voltage	V	218.7
UOP Motor voltage	V	0.0
LCR Motor Current	A	0.0
THD Drive Thermal	%	44.0
THRl Motor Thermal	%	0.0
OPR Output Power	%	0.0
APH Power Used	kWh	0.0
RTH Run Time	h	0.0

L11	L17	A11	0.0040	R1
L12	L18	A12	0.01	R2
L13	L19	A13	0.0	R3
L14	L10	A14	0.0	R4
L15	L11	A01	0.0	L01
L16	L12	A02	0.0	L02
	L13	A03	0.0	L03
	L14			L04

11. Web server

■ Drive parameters

The screenshot shows the web interface for an Altivar 71-61 drive. The top navigation bar includes 'Home' and 'Documentation'. Below it, there are tabs for 'Drive', 'Network setup', 'Network diagnostic', and 'Email'. The main content area is titled 'Drive parameters' and features a sidebar with a tree view of parameter categories. The 'Measurement parameters' category is selected, displaying a table of parameters.

Parameter	Address	UnitId	Description	Value	Unit
7391	0		Date	0	
7392	0		Time	0	
3207	0		Mains voltage	218.8	V
3230	0		Energy consumption	0	Wh
3209	0		Drive thermal state	44	%
9630	0		Motor thermal state	0	%
14114	0		Resistor thermal state	0	%
3231	0		Total motor operating time	0	s
3232	0		Internal motor operating time	0	s
3233	0		Total drive operating time	6	s
3235	0		IGBT alarm time	0	s
12209	0		Current bobbin time	0	min

At the bottom of the interface, there is a status bar showing 'Started, number of requests = 8' and response times of 125ms, 93ms, and 125ms. The copyright notice at the bottom reads '© 2007 Schneider Electric. All Rights Reserved.'

The left column is used to select a mod/imd group of parameters. The right side of the window displays the parameters, their Modbus addresses, and their current values.

■ Saving parameters

To avoid numerous writes to the flash memory, when drive controller parameters are modified from the web server, they are not saved into drive memory. However, it is possible to backup the parameters from the web server by writing 2 to the CMI parameter. This operation saves the drive controller parameters to flash memory.

11. Web server

■ Drive recorder

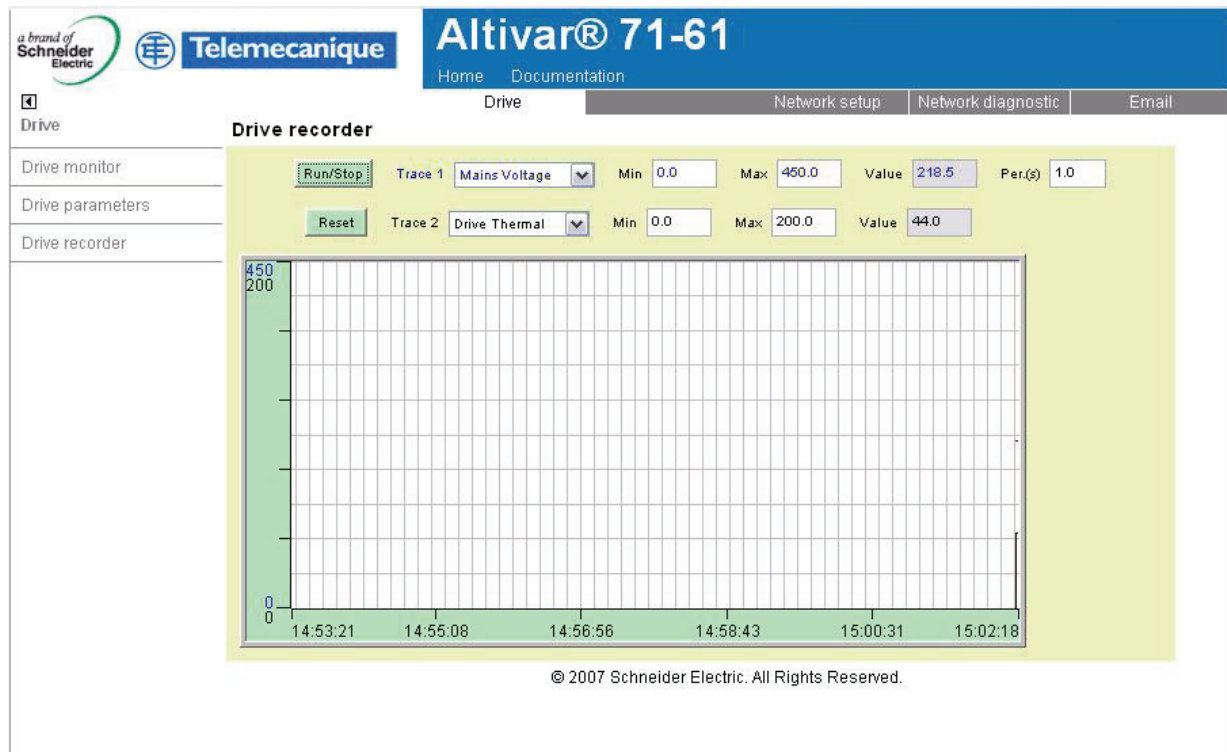

The Drive recorder plots two preselected parameters as a graph to display trends.

RUN/STOP: Starts or stops the trend recording.

Reset: Erases the recorded trend.

Min/Max: defines the lowest and highest values displayed on the Drive recorder window.

Per(s): Periodicity: Minimal value.

11. Web server

11. 4. Network setup



■ Monitor security

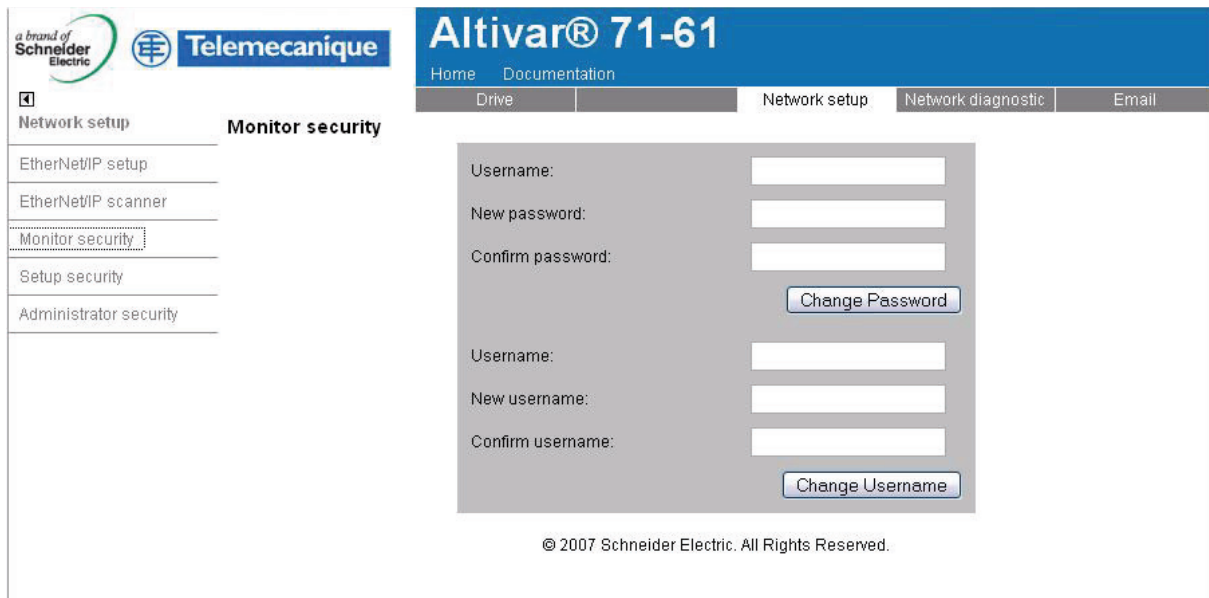

The Monitor security password provides basic level access to the drive controller through the web server. It allows access to the various web pages, but does not authorize write access. The monitor security user name and password can be changed in this window.

11. Web server

■ Setup security

The screenshot shows the web interface for the Altivar 71-61 drive. The page title is "Altivar® 71-61". The navigation menu includes "Home", "Documentation", "Drive", "Network setup", "Network diagnostic", and "Email". The "Network setup" menu is expanded, showing "EtherNet/IP setup", "EtherNet/IP scanner", "Monitor security", "Setup security" (which is selected), and "Administrator security". The main content area is titled "Setup security" and contains three password input fields: "Data Editor Write password:", "New write password:", and "Confirm write password:". A "Change Write Password" button is located below the fields. The footer text reads "© 2007 Schneider Electric. All Rights Reserved."

- HTTP: data write.
- Data write level password.

■ Administrator security

The screenshot shows the web interface for the Altivar 71-61 drive, specifically the "Administrator security" page. The navigation menu is similar to the previous page, but "Administrator security" is selected. The main content area is titled "Administrator security" and contains two sections. The first section has a "Login:" field with "Administrator" entered, a "Password:" input field, a "New password:" input field, and a "Confirm password:" input field. A "Change adm password" button is located below these fields. The second section has a "Login:" field with "Administrator" entered and a "Password:" input field. A "Reset all user right" button is located below this section. The footer text reads "© 2007 Schneider Electric. All Rights Reserved."

11. Web server

■ EtherNet/IP setup

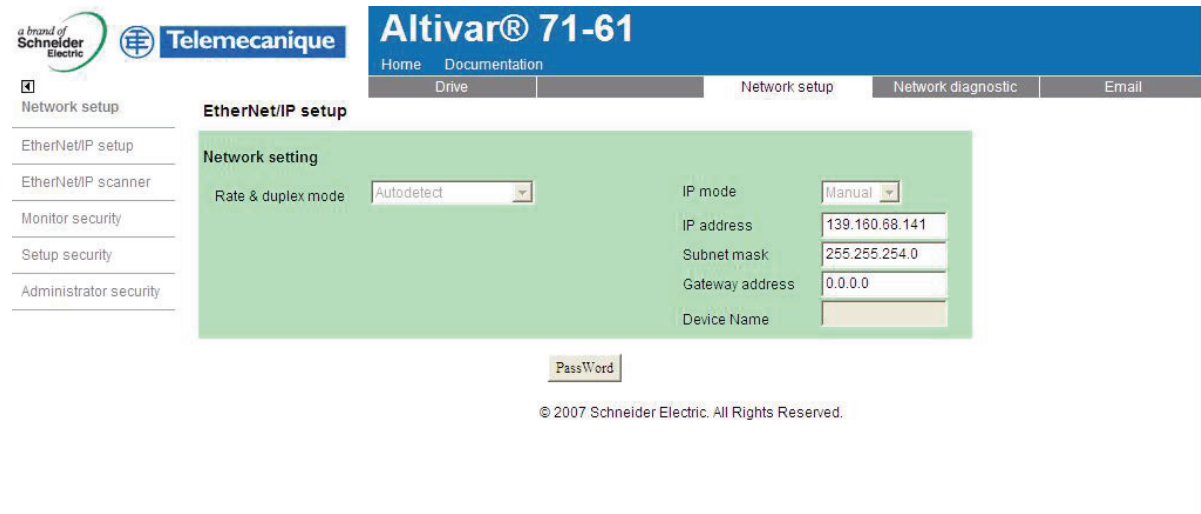

a brand of Schneider Electric | Telemecanique | **Altivar® 71-61**
 Home | Documentation
 Drive | Network setup | Network diagnostic | Email

Network setup | **EtherNet/IP setup** | EtherNet/IP scanner | Monitor security | Setup security | Administrator security

EtherNet/IP setup
Network setting
 Rate & duplex mode: Autodetect | IP mode: Manual
 IP address: 139.160.68.141
 Subnet mask: 255.255.254.0
 Gateway address: 0.0.0.0
 Device Name:
 PassWord:

© 2007 Schneider Electric. All Rights Reserved.

■ EtherNet/IP scanner setup

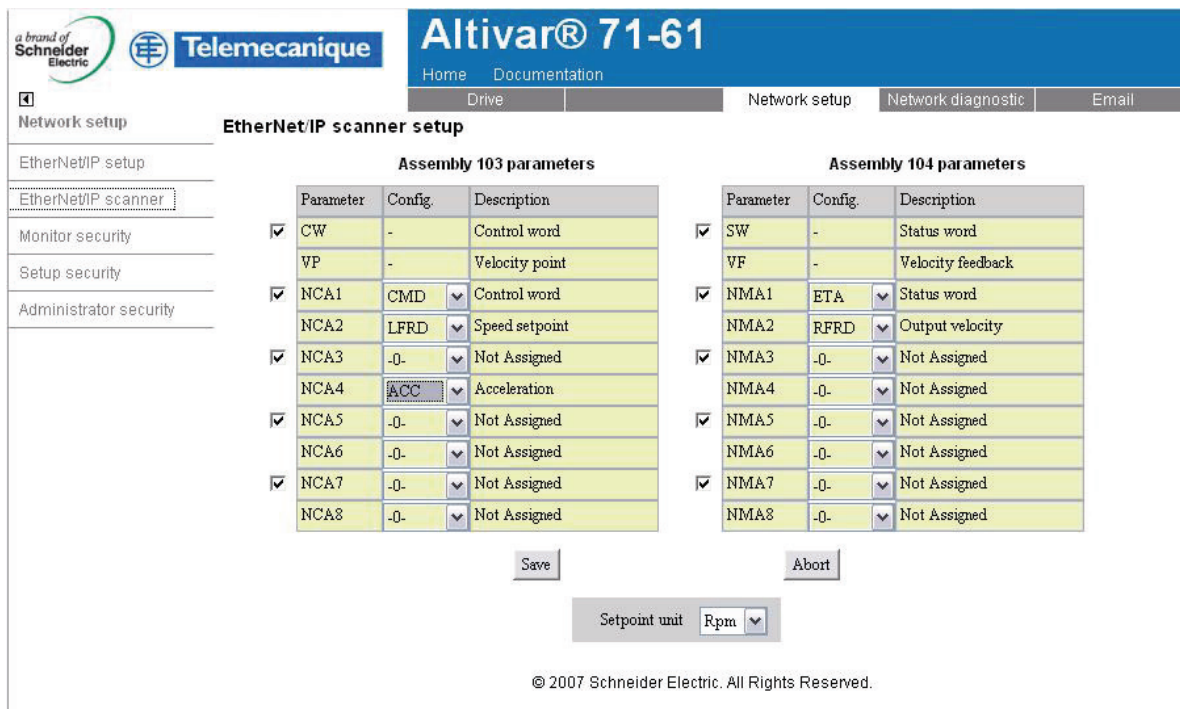

a brand of Schneider Electric | Telemecanique | **Altivar® 71-61**
 Home | Documentation
 Drive | Network setup | Network diagnostic | Email

Network setup | EtherNet/IP setup | **EtherNet/IP scanner** | Monitor security | Setup security | Administrator security

EtherNet/IP scanner setup
Assembly 103 parameters

Parameter	Config	Description
<input checked="" type="checkbox"/> CW	-	Control word
VP	-	Velocity point
<input checked="" type="checkbox"/> NCA1	CMD	Control word
NCA2	LFRD	Speed setpoint
<input checked="" type="checkbox"/> NCA3	-0-	Not Assigned
NCA4	ACC	Acceleration
<input checked="" type="checkbox"/> NCA5	-0-	Not Assigned
NCA6	-0-	Not Assigned
<input checked="" type="checkbox"/> NCA7	-0-	Not Assigned
NCA8	-0-	Not Assigned

Assembly 104 parameters

Parameter	Config	Description
<input checked="" type="checkbox"/> SW	-	Status word
VF	-	Velocity feedback
<input checked="" type="checkbox"/> NMA1	ETA	Status word
NMA2	RFRD	Output velocity
<input checked="" type="checkbox"/> NMA3	-0-	Not Assigned
NMA4	-0-	Not Assigned
<input checked="" type="checkbox"/> NMA5	-0-	Not Assigned
NMA6	-0-	Not Assigned
<input checked="" type="checkbox"/> NMA7	-0-	Not Assigned
NMA8	-0-	Not Assigned

Save | Abort
 Setpoint unit: Rpm

© 2007 Schneider Electric. All Rights Reserved.

See page 15. The default assignment of NCA1 and NCA2 must be removed when using the assembly 103 and 104 profile.

11. Web server

■ Email management

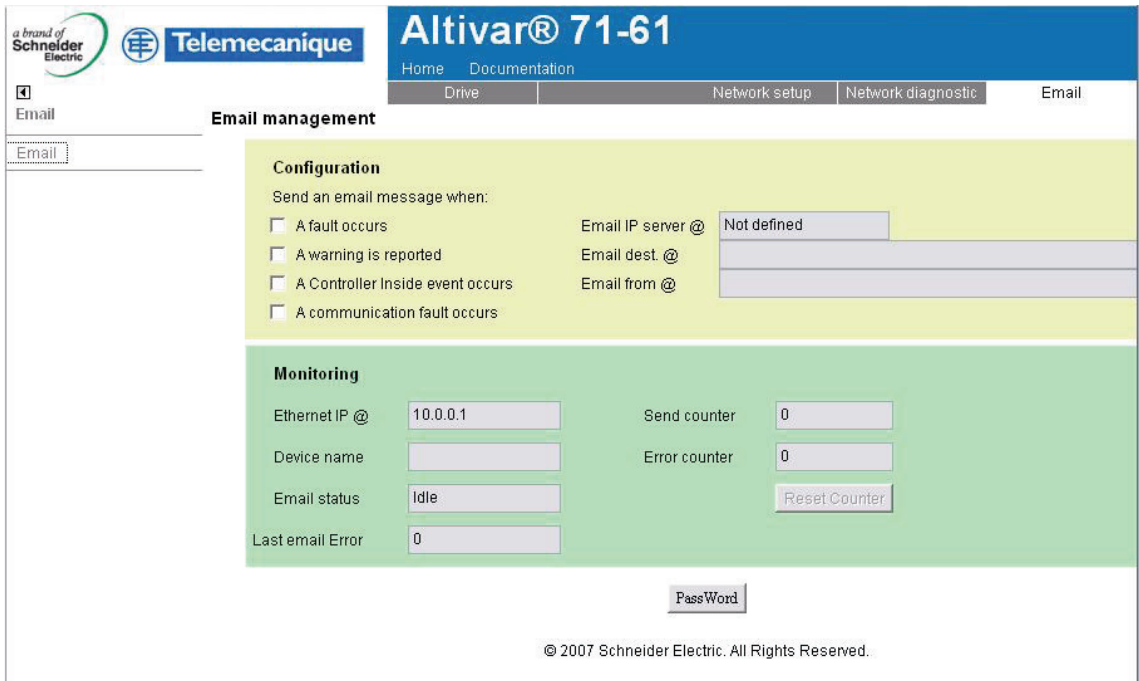

The Email management window allows you to send an email under one of four selectable conditions. You can also specify:

- The email IP server address
- The email recipient's address
- The email sender's address

11. 5. Diagnostics



11. Web server

■ Ethernet statistics

Altivar® 71-61
Home Documentation

Drive Network setup Network diagnostic Email

Ethernet statistics

Device Type	ALTIVAR 71	Data rate	100 Mbit/s	IP address	10.0.0.1
Device reference	ATV71H075M3	Duplex mode	Full Duplex	Subnet mask	255.255.255.0
Software revision	1.0ie01			Gateway address	0.0.0.0
MAC Address	00-80-f4-7d-00-03			IP mode	Manual
				Device name	Not defined

Transmit		Receive		Other errors	
Transmit counter	57818	Receive counter	67668	Collisions	0
Transmit errors	0	Receive errors	0	Multi Collisions	0
				Over Run	0
Deferred Emissions	0	CRC errors	0		
Late collisions	0	Frame errors	0		
Buffer Errors	0	Buffer Errors	0		

Reset counters

© 2007 Schneider Electric. All Rights Reserved.

■ Message statistics

Altivar® 71-61
Home Documentation

Drive Network setup Network diagnostic Email

Message statistics

TCP/UDP

Open sockets	5	CIP open connections	0
		Modbus open connections	1

CIP

Assemblies			I/O messaging		Explicit messaging	
	Instance	Size				
Input	0	0	Transmit counter	0	UCMM request	0
Output	0	0	Receive counter	0	UCMM error	0
			Error counter	0	Class3 request	0
					Class3 error	0

Modbus TCP

Transmit counter	2582
Receive counter	2593
Error counter	0

Reset counters

© 2007 Schneider Electric. All Rights Reserved.

NOTE: The EtherNet/IP option card uses internal MODBUS TCP for the web-server. The MODBUS TCP port is not accessible.

12. Integration in RSLogix

12.1. Principle

An Altivar 61/71 drive controller equipped with an EtherNet/IP card can be configured as a generic ethernet module in the same way as the EtherNet/IP adapter of the Powerflex 70 drives as show in section 12.2, or an EDS file can be used as shown in section 12.3 beginning on page 41.

12.2. Procedure

- Create a new project (project name is RSX for this example)

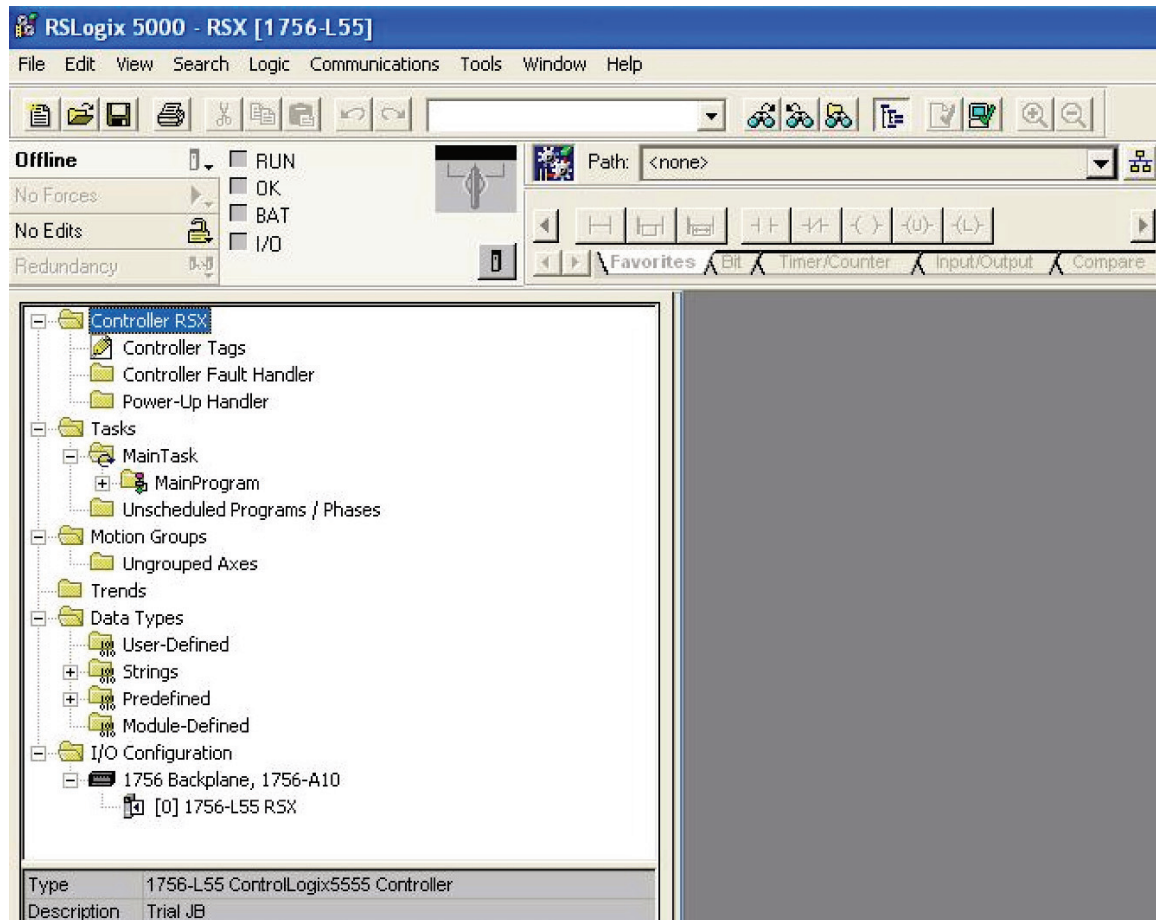

12. Integration in RSLogix

■ Add a EtherNet/IP scanner to the I/O configuration

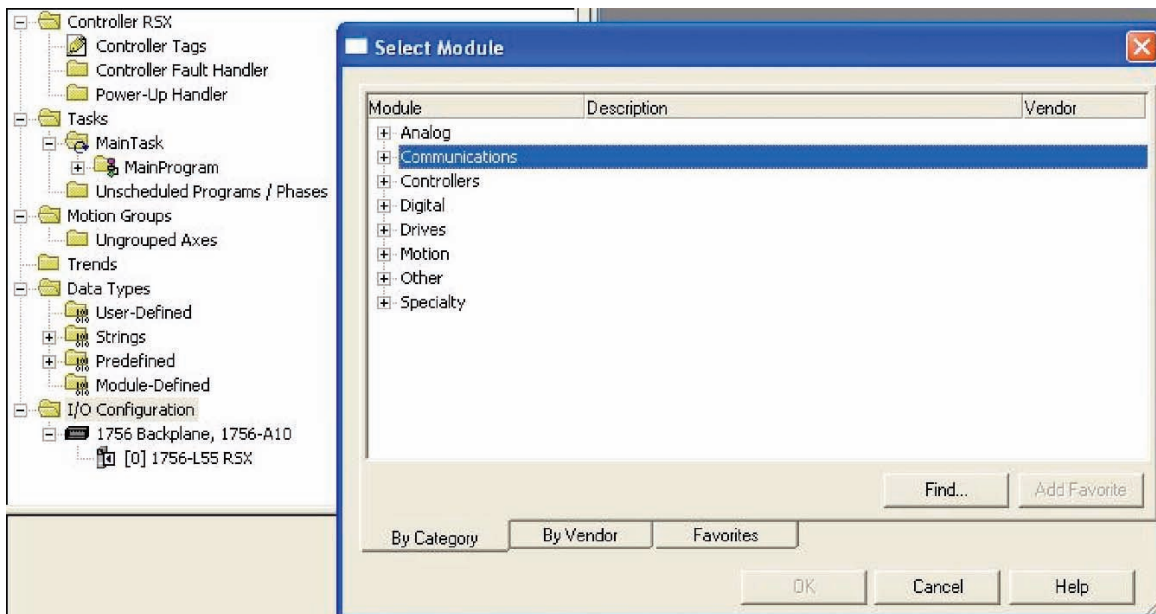
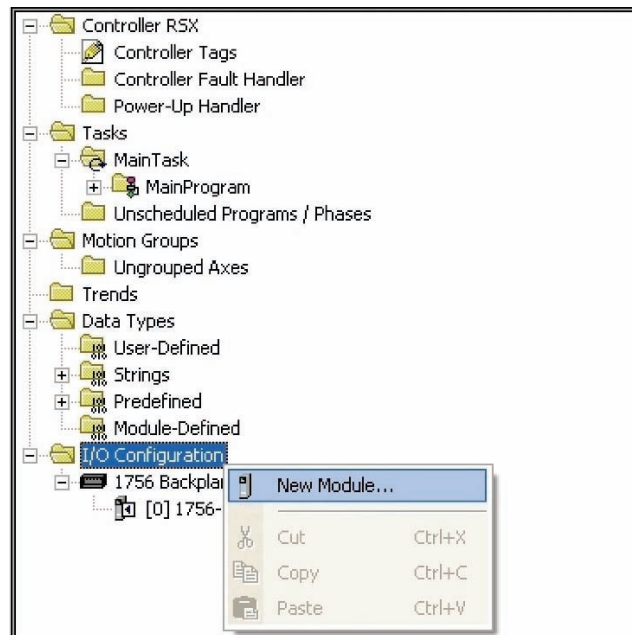

12. Integration in RSLogix

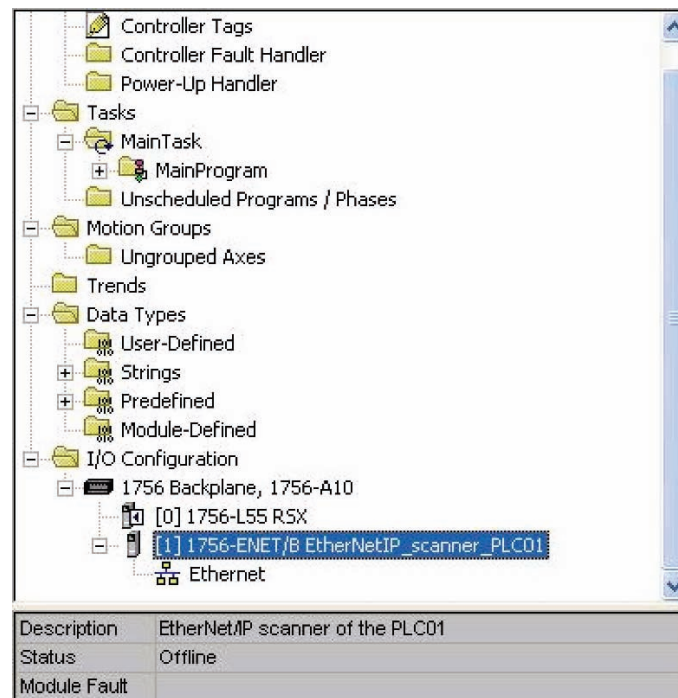
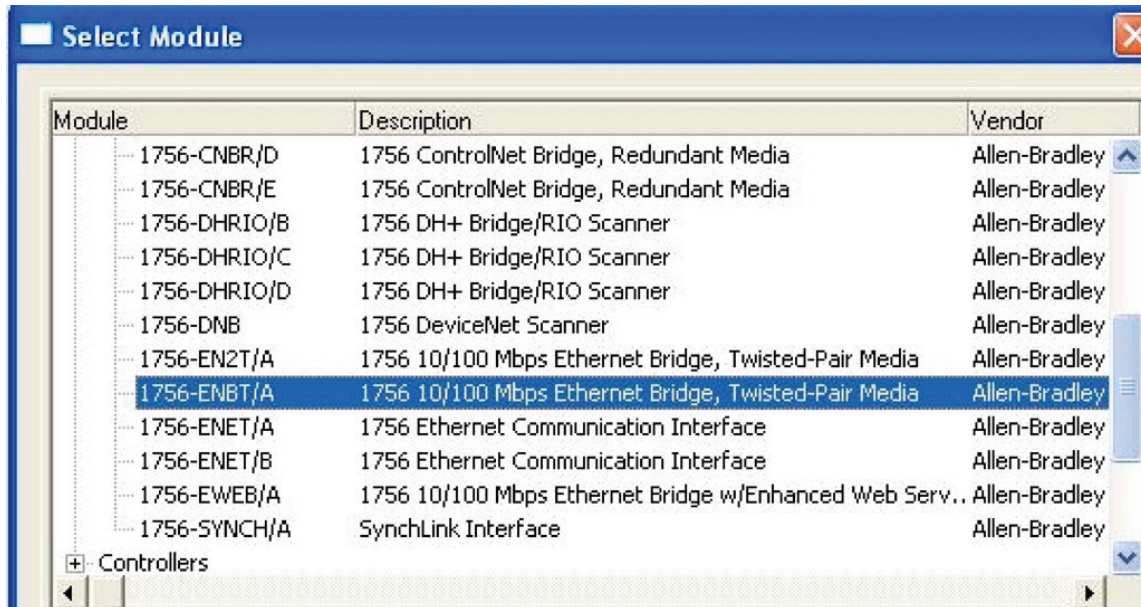

12. Integration in RSLogix

■ Configure the EtherNet/IP scanner

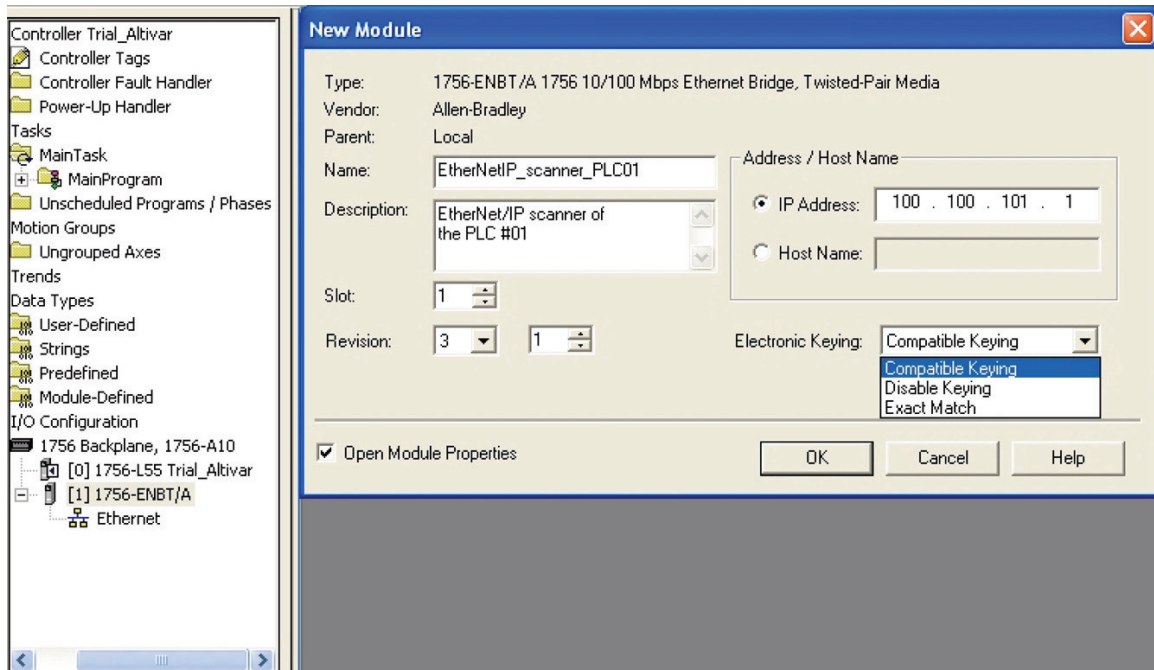

■ Add a EtherNet/IP ATV61/71 drive controller to the I/O configuration

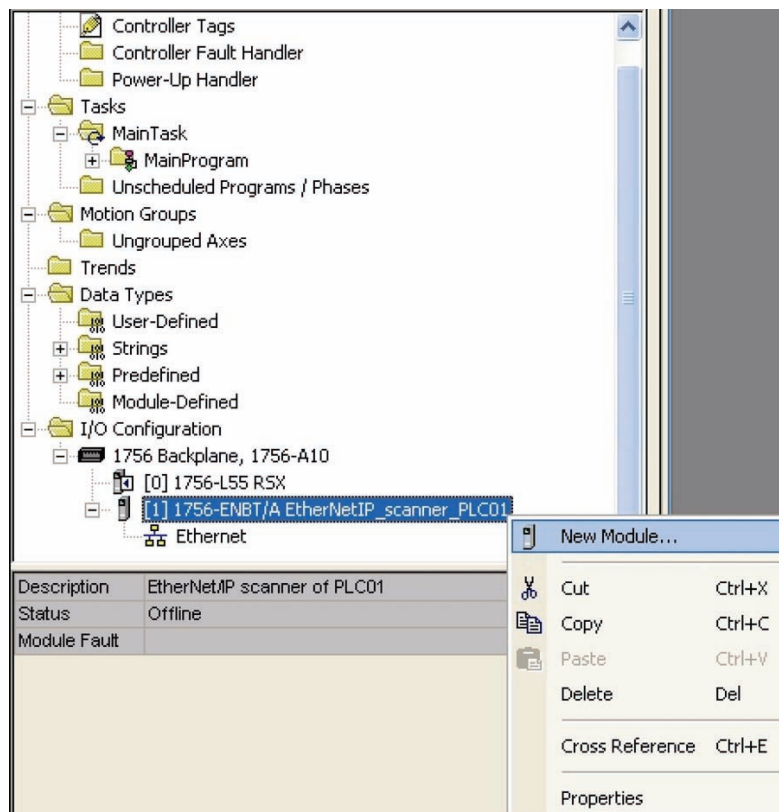

12. Integration in RSLogix

The screenshot shows the RSLogix software interface. On the left, a hardware rack configuration is visible under 'I/O Configuration'. It includes a '1756 Backplane, 1756-A10', a '1756-L55 RSX' module, and a '1756-ENBT/A EtherNet/IP_scanner_PLC01' module. Below the rack, a status table is shown:

Description	EtherNet/IP scanner of PLC01
Status	Offline
Module Fault	

On the right, the 'Select Module' dialog box is open. It displays a list of modules with columns for 'Module', 'Description', and 'Vendor'. The 'Communications' category is expanded, showing 'Drives' and 'HMI' sub-categories.

The screenshot shows the RSLogix software interface with a more detailed view of the 'Select Module' dialog. The hardware rack configuration on the left is identical to the previous screenshot. The status table is also the same:

Description	EtherNet/IP scanner of PLC01
Status	Offline
Module Fault	

The 'Select Module' dialog box is now showing a list of specific modules. The 'ETHERNET-MODULE Generic Ethernet Module' is selected. The list includes various Ethernet modules and adapters from Allen-Bradley and Parker Hannifin. At the bottom of the dialog, there are buttons for 'Find...', 'Add Favorite', and sorting options: 'By Category', 'By Vendor', and 'Favorites'. 'OK', 'Cancel', and 'Help' buttons are also present.

12. Integration in RSLogix

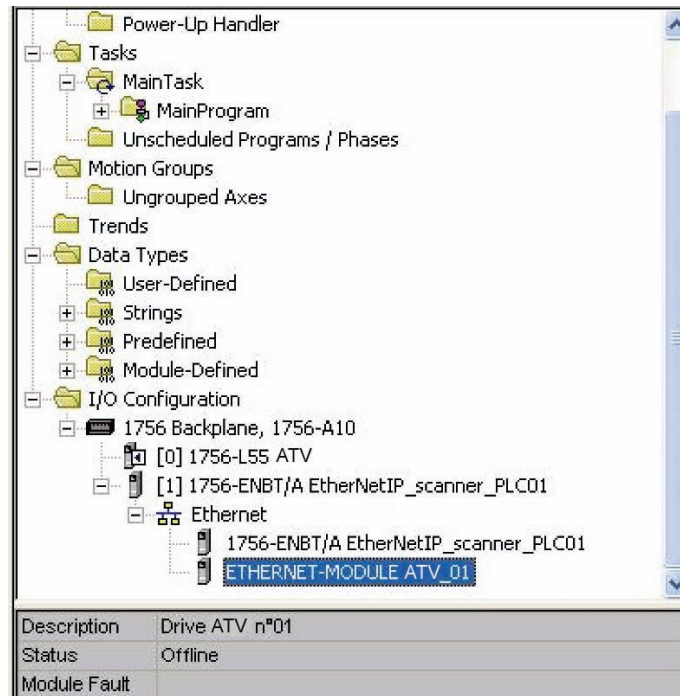

■ Configure the ATV61/71 EtherNet/IP card

In the following example, the Allen-Bradley Drive profile is selected.

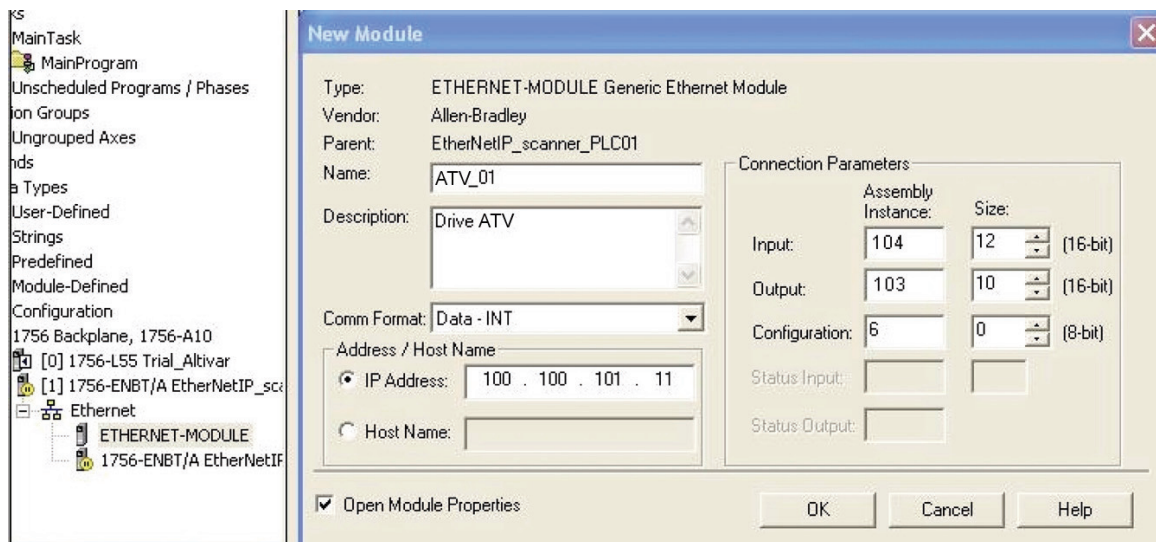

12. Integration in RSLogix

In the following example, the CIP extended speed control profile is selected.

New Module

Type: ETHERNET-MODULE Generic Ethernet Module
Vendor: Allen-Bradley
Parent: EtherNetIP_scanner_PLC01

Name:

Description:

Comm Format:

Address / Host Name
 IP Address:
 Host Name:

Connection Parameters

	Assembly Instance:	Size:	
Input:	<input type="text" value="71"/>	<input type="text" value="4"/> (16-bit)	
Output:	<input type="text" value="21"/>	<input type="text" value="2"/> (16-bit)	
Configuration:	<input type="text" value="6"/>	<input type="text" value="0"/> (8-bit)	
Status Input:	<input type="text"/>	<input type="text"/>	
Status Output:	<input type="text"/>	<input type="text"/>	

Open Module Properties

OK Cancel Help

In the following example, the CIP extended speed and torque control profile is selected.

Module Properties: EtherNetIP_scanner_PLC01 (ETHERNET-MODULE 1.1)

General | Connection | Module Info

Type: ETHERNET-MODULE Generic Ethernet Module
Vendor: Allen-Bradley
Parent: EtherNetIP_scanner_PLC01

Name:

Description:

Comm Format:

Address / Host Name
 IP Address:
 Host Name:

Connection Parameters

	Assembly Instance:	Size:	
Input:	<input type="text" value="73"/>	<input type="text" value="5"/> (16-bit)	
Output:	<input type="text" value="23"/>	<input type="text" value="3"/> (16-bit)	
Configuration:	<input type="text" value="6"/>	<input type="text" value="0"/> (8-bit)	
Status Input:	<input type="text"/>	<input type="text"/>	
Status Output:	<input type="text"/>	<input type="text"/>	

Status: Offline

OK Cancel Apply Help

12. Integration in RSLogix

In the following example, the RSX profile is selected.

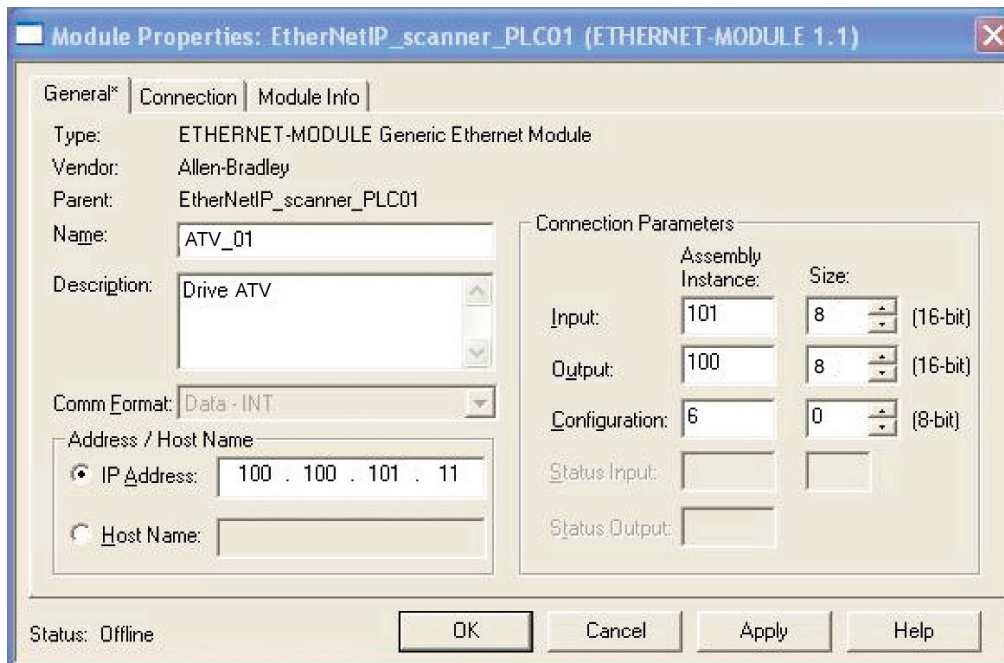

12.3. Registering the EDS file in RSLogix

An EDS file is provided on the CD that ships with the drive controller. There is 1 EDS file for the ATV71 and 1 EDS file for the ATV61. This section describes how to import these files in your project:

In RSnetWorx, start the EDS Wizard.

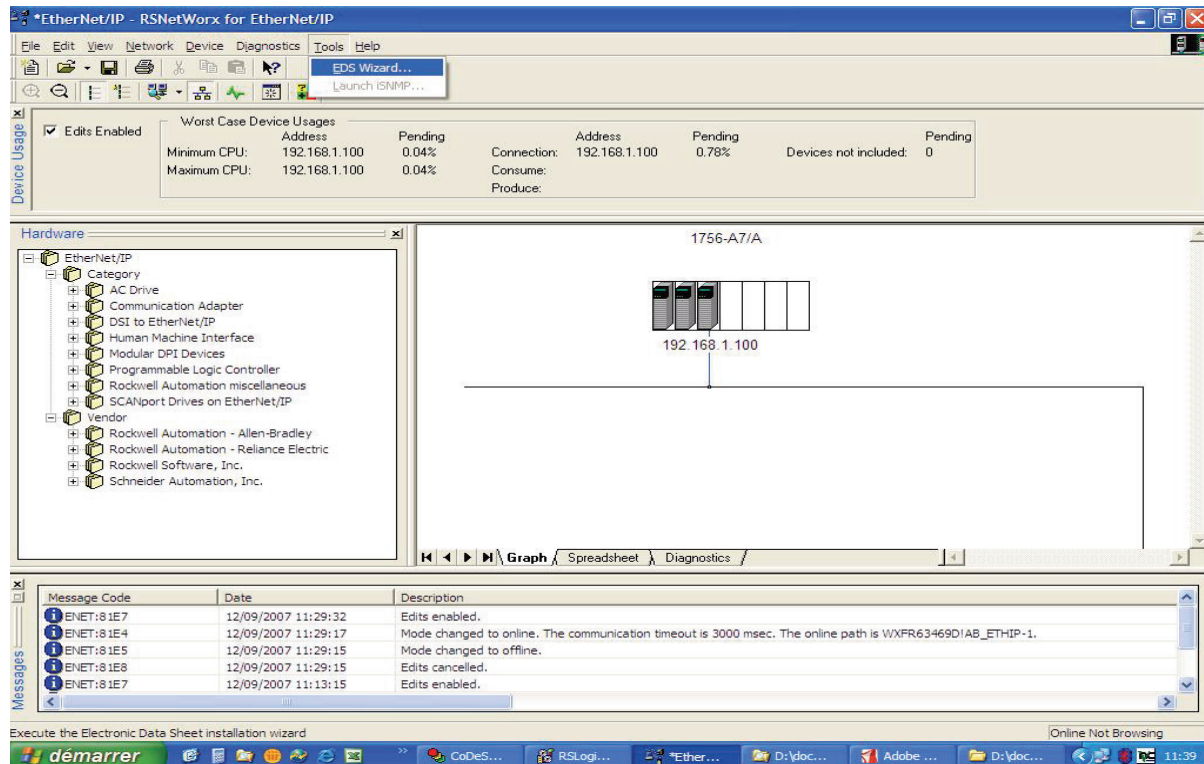

12. Integration in RSLogix

Click Next (Suivant) to continue.



Choose "Register an EDS file(s)" to import a new EDS file.
If you want to update an EDS file, you must unregister device first.



12. Integration in RSLogix

Select the required file, then click Open (Ouvrir):

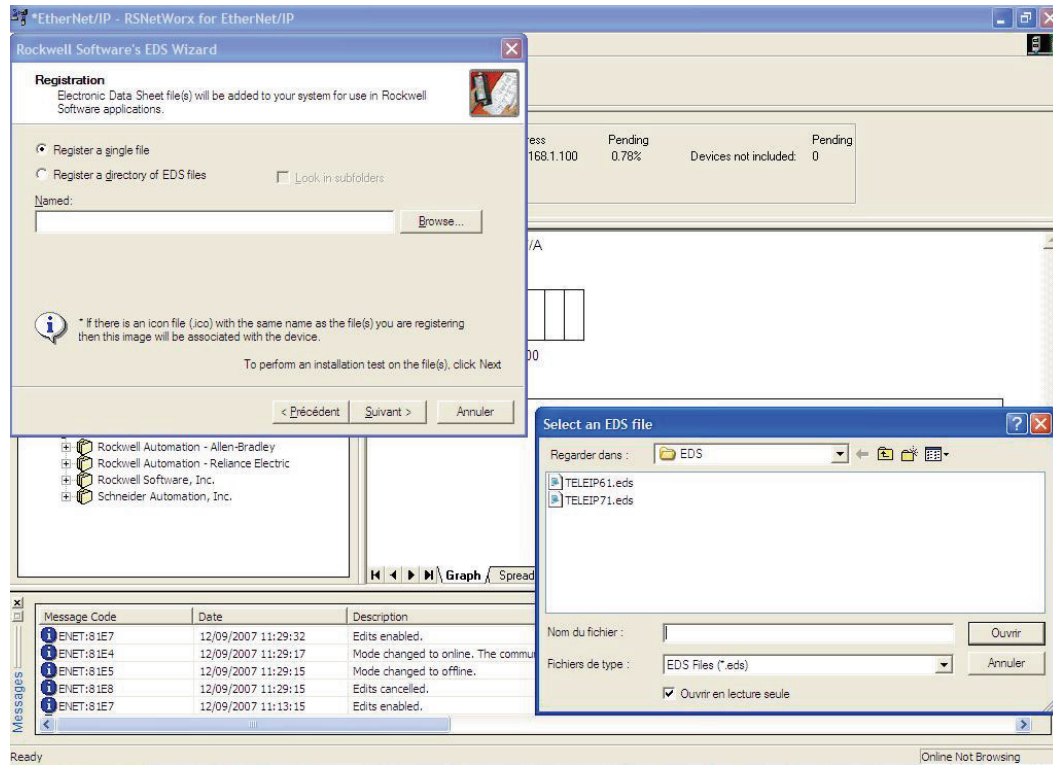

The dialog box displays the result of the import operation.



13. CIP objects

13. 1. Supported object classes

Three categories of object classes can be defined:

- 1: CIP device on EtherNet/IP
- 2: AC/DC drive controller
- 3: VSD specific

The following table describes these objects.

Object class	Class ID	Cat.	Number of instances	Effect on behavior Interface
Identity object (13. 2.) page 44	16#01	1	1	Supports the reset service
Message router object (13. 3.) page 45	16#02	1	1	Explicit message connection
Ethernet Link object (13. 4.) page 47	16#F6	1	1	Counter and status information
TCP/IP Interface object (13. 5.) page 50	16#F5	1	1	TCP/IP configuration
Connection object manager (13. 6.) page 52	16#05	1	1	
Motor data object (13. 7.) page 53	16#28	2	1	Defines data for the motor connected to the device
Control supervisor object (13. 8.) page 54	16#29	2	1	Manages drive functions, operational states and control
AC/DC Drive Object (13. 9.) page 56	16#2A	2	1	Provides drive configuration
Assembly object (13. 10.) page 57	16#04	2	12	Defines I/O data format
Application objects (13. 11.) page 58		3	1	Vendor specific - drive controller's parameters

13. 2. Identity object

The Identity object provides identification and status information about the drive controller.

Class code

Hexadecimal	Decimal
16#01	1

Class attributes

Attribute ID	Access	Name	Need	Data type	Value	Details
1	Get	Revision	Optional	UINT	1	—
2	Get	Max Instances	Optional	UINT	1	1 defined instance

13. CIP objects

Instance attributes

Attribute ID	Access	Name	Need	Data type	Value	Details
1	Get	Vendor ID	Required	UINT	243	Schneider Automation, Inc. [243]
2	Get	Device type	Required	UINT	16#02	AC/DC drive profile
3	Get	Product code	Required	UINT	5 or 7	5: ATV71 7: ATV61
4	Get	Revision	Required	Structure of: USINT USINT	—	Product revision of the drive controller (1)
5	Get	Status	Required	WORD	—	See definition in the table below
6	Get	Serial number	Required	UDINT	—	Serial number of the drive controller
7	Get	Product name	Required	Structure of: USINT STRING	—	11 (product name length) "ATV71 Drive"
8	Get	State	Optional	USINT	—	0: Non existent 1: Device self-testing 2: Standby 3: Operational 4: Major recoverable fault 5: Major unrecoverable fault
10	Get/Set	Heartbeat interval (2)	Optional	USINT	0–255	Interval in seconds between two heartbeat messages. 0: No message.

(1) Mapped in a word: MSB minor revision (second USINT), LSB major revision (first USINT).
Example: 517 = 16#0205 means revision V5.2.

(2) The heartbeat message broadcasts the current state of the device.

13.3. Message router object

The Message router object directs explicit messages to their target objects.

Class code

Hexadecimal	Decimal
16#02	2

Class attributes

Attribute ID	Access	Name	Need	Data type	Value	Details
1	Get	Revision	Optional	UINT	1	—
2	Get	Max instances	Optional	UINT	1	1 Defined instance

13. CIP objects

Instance attributes

Attribute ID	Access	Name	Need	Data type	Value	Details
1	Get	Object list: Number classes	Optional	Structure of: UINT UINT []	20 (codes)	List of supported objects; the first UINT is the number of supported classes; the remaining UINTs are the codes of these classes.
2	Get	Number available	Optional	UINT	1	Maximum number of simultaneous connections
3	Get	Number active	Optional	UINT	1	Number of active connections
4	Get	Active connections	Optional	UINT []	1	List of active connections (referred to with their respective Connection instance ID)

Class service

Service code	Service name	Need	Description
16#0E	Get_Attribute_Single	Required	Read an attribute

Instance service

Service code	Service name	Need	Description
16#0E	Get_Attribute_Single	Required	Read an attribute

13. CIP objects

13.4. Ethernet Link object

This object provides the mechanism to configure a device's TCP/IP network interface.

■ Class code

Hexadecimal	decimal
16#F5	245

■ Class attributes

Class attributes for this object are optional.

■ Instance attributes

Attribute ID	Access	Name	Need	Data type	Value	Details	
1	Get	Status	Required	DWORD	Bit level	0	The interface configuration attribute has not been configured.
						1	The interface configuration contains a valid configuration.
						2–15	Reserved for future use.
2	Get	Configuration capability	Required	DWORD	Bit level	0	BOOTP Client
						1	DNS Client
						2	DHCP Client
						3	DHCP-DNS capable
						4	Interface configuration settable
						The other bits are reserved and are set to 0.	
3	Get Set	Configuration control	Required	DWORD	Bit level	0	The interface configuration is valid.
						1	The interface configuration must be obtained with BOOTP.
						2	The interface configuration must be obtained with DHCP.
						3	Reserved
						4	DNS Enable
The other bits are reserved and are set to 0.							
NOTE: This attribute interacts with the Altivar 71 parameter [IP mode]. (see chapter 8.).							
4	Get	Physical link	Required	STRUCT { UINT path size Padded EPATH path }		Path size: The number of 16 bit words in the element path. Path: Logical segments identifying the physical link object. The path is restricted to one logical class segment and one logical instance segment. The maximum size is 12 bytes.	

13. CIP objects

Attribute ID	Access	Name	Need	Data type	Value	Details
5	Get Set	Interface configuration	Required	STRUCT { UDINT IP Address UDINT Network Mask UDINT Gateway address UDINT Primary Name server UDINT Secondary name server STRING Default Domain name }		<p>IP Address: Value of 0 indicates that no IP address has been configured. Otherwise, the IP address must be set to a valid Class A, B, or C address and must not be set to the loopback address (127.0.0.1).</p> <p>Network Mask: Value of 0 indicates that no network mask address has been configured.</p> <p>Gateway Address: Value of 0 indicates that no IP address has been configured. Otherwise, the IP address must be set to a valid Class A, B, or C address and must not be set to the loopback address (127.0.0.1).</p> <p>Primary name: Value of 0 indicates that no name server address has been configured. Otherwise, the name server address must be set to a valid Class A, B, or C address.</p> <p>Secondary Name: Value of 0 indicates that no secondary name server address has been configured. Otherwise, the name server address must be set to a valid Class A, B, or C address.</p> <p>Default domain name: ASCII characters. Maximum length is 48 characters, padded to an even number of characters (pad not included in length). A length of 0 indicates that no Domain Name is configured.</p>
6	Get Set	Host Name	Required	STRING		ASCII characters. Maximum length is 64 characters, padded to an even number of characters (pad not included in length). A length of 0 indicates that no Host Name is configured.

■ Class service

Service Code	Service Name	Need	Description
16#01	Get_Attribute_All	Optional	Returns a predefined listing of this object's attributes.
16#0E	Get_Attribute_Single	Optional	Returns the contents of the specified attribute.

■ Instance service

Service Code	Service Name	Need	Description
16#01	Get_Attribute_All	Optional	Returns a predefined listing of this objects attributes.
16#0E	Get_Attribute_Single	Required	Returns the contents of the specified attribute.
16#02	Set_Attribute_All	optional	Modifies all settable attributes.
16#10	Set_Attribute_Single	Required	Modifies a single attribute.

13. CIP objects

■ Behavior

The following diagram illustrates configuration of the TCP/IP network interface.

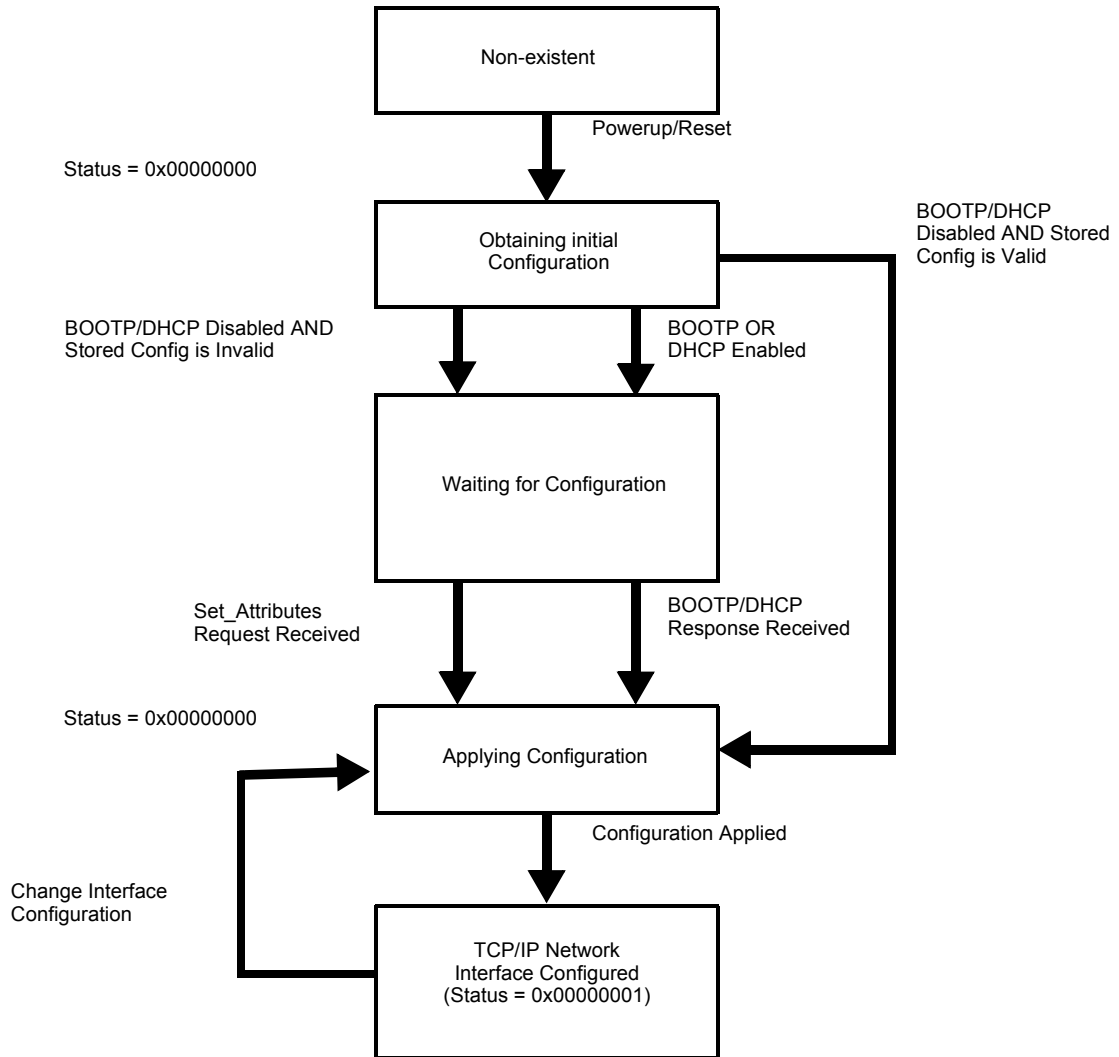

13. CIP objects

13.5. TCP/IP Interface object

This object maintains link specific counters and status information for an Ethernet 802.3 communications interface.

■ Class code

Hexadecimal	Decimal
16#F6	246

■ Class attributes

Attribute ID	Access	Name	Need	Data type	Value
1	Get	Revision	Required	UINT	2
2 through 7			Optional		

■ Instance attributes

Attribute ID	Access	Name	Need	Data type	Value	Details										
1	Get	Interface Speed	Required	UDINT	0,10,100 1000, etc.	Speed in Mbps.										
2	Get	Interface flags	Required	DWORD	Bit level	<table border="1"> <tr> <td>0</td> <td>Link status</td> </tr> <tr> <td>1</td> <td>Half/full duplex</td> </tr> <tr> <td>2-4</td> <td>Negotiation status</td> </tr> <tr> <td>5</td> <td>Manual setting / requires reset</td> </tr> <tr> <td>6</td> <td>Local hardware error</td> </tr> </table> <p>The other bits are reserved and set to 0.</p>	0	Link status	1	Half/full duplex	2-4	Negotiation status	5	Manual setting / requires reset	6	Local hardware error
0	Link status															
1	Half/full duplex															
2-4	Negotiation status															
5	Manual setting / requires reset															
6	Local hardware error															
3	Get	Physical Address	Required	ARRAY OF 6 USINTs		This array contains the MAC address of the card. Format: XX-XX-XX-XX-XX-XX										
4 ...	Get	Interface counters	Conditional	STRUCT {												
				UDINT In Octets		Octets received on the interface										
				UDINT In Ucast Packets		Unicast packets received on the interface.										
				UDINT In NUcast Packets		Non Unicast packets received on the interface.										
				UDINT In Discards		Inbound packets received on the interface, but discarded.										
				UDINT In Errors		Inbound packets contain errors. (Does not include In Discards. See entry above.)										
				UDINT In Unknown Protos		Inbound packets with unknown protocol.										
				UDINT Out Octets		Octets sent on the interface.										
				UDINT Out Ucast packets		Unicast packets sent on the interface.										
				UDINT Out NUcast Packets		Non Unicast packets sent on the interface.										
				UDINT Out Discards		Outbound packets discarded.										
				UDINT		Outbound packets contain errors.										
				}												

13. CIP objects

Attribute ID	Access	Name	Need	Data type	Value	Details
5	Get	Media Counters	Conditional	STRUCT {		
				UDINT Alignment errors		Frames received that are not an integral number of octets in length
				UDINT FCS Errors		Frames received that do not pass the FCS check
				UDINT Single collisions		Successfully transmitted frames experienced one collision
				UDINT Multiple Collisions		Successfully transmitted frames experienced more than one collision
				UDINT SQE Test Errors		Number of times SQE test error message is generated
				UDINT Deferred Transmissions		Frames for which first transmission attempt is delayed because the medium is busy
				UDINT Late Collisions		Number of times a collision is detected later than 512 bittimes into the transmission of a packet
				UDINT Excessive Collisions		Frames for which transmission is unsuccessful due to excessive collision
				UDINT MAC Transmit errors		Frames for which transmission is unsuccessful due to an internal MAC sublayer transmit error
				UDINT Carrier sense Errors		Times that the carrier sense condition was lost or never asserted when attempting to transmit a frame
				UDINT Frame too long		Frames received that exceed the maximum permitted frame size
				UDINT MAC Receive Errors		Frames for which reception on an interface is unsuccessful due to an internal MAC sublayer receive error
			}			
6	Set	Interface control	Optional	STRUCT {		
				WORD Control Bits		Interface control bits
				UINT Force interface Speed		Speed at which the interface is forced to operate.
						}

13. CIP objects

■ Class service

Service Code	Service Name	Need	Description
16#01	Get_Attribute_All	Optional	Returns a predefined listing of this object's attributes.
16#0E	Get_Attribute_Single	Optional	Returns the contents of the specified attribute.
16#10	Get_and_clear	Conditional	Modifies a single attribute

■ Instance service

Service Code	Service Name	Need	Description
16#01	Get_Attribute_All	Optional	Returns a predefined listing of this object's attributes.
16#0E	Get_Attribute_Single	Required	Returns the contents of the specified attribute.
16#10	Set_Attribute_Single	Required	Modifies a single attribute.

13. 6. Connection object manager

Class code

Hexadecimal	Decimal
16#05	5

Class attributes

Attribute ID	Access	Name	Need	Data type	Value	Details
1	Get	Revision	Optional	UINT	1	—
2	Get	Max instances	Optional	UINT	4	3 defined instances (1)

(1) Only instances 1 (explicit message), 2 (polled I/O message), and 4 (change of state/cyclic message) are supported. Instance 3 (bit strobe) is not supported.

Attributes of instance 1—Explicit message instance

Attribute ID	Access	Name	Need	Data type	Value	Details
1	Get	State	Req.	USINT	—	0: Non-existent 3: Established 5: Deferred delete
2	Get	Instance_type	Req.	USINT	0	Explicit message
3	Get	TransportClass_trigger	Req.	BYTE	16#83	Class 3 server
4	Get	Produced_connection_id	Req.	UINT	10xxxxxx011	xxxxxx = Node address
5	Get	Consumed_connection_id	Req.	UINT	10xxxxxx100	xxxxxx = Node address
6	Get	Initial_comm_characteristics	Req.	BYTE	16#21	Explicit messaging via Group 2
7	Get	Produced_connection_size	Req.	UINT	36	Produced data maximum size (in bytes)
8	Get	Consumed_connection_size	Req.	UINT	36	Consumed data maximum size (in bytes)
9	Get/Set	Expected_packet_rate	Req.	UINT	2500	2.5 sec. (Time-out)
12	Get/Set	Watchdog_timeout_action	Req.	USINT	1 or 3	1: Auto-delete 3: Deferred delete (default)
13	Get	Produced connection path length	Req.	UINT	0	Length of attribute 14 data
14	Get	Produced connection path	Req.	Array of UINT	Null	Empty
15	Get	Consumed connection path length	Req.	UINT	0	Length of attribute 16 data
16	Get	Consumed connection path	Req.	Array of UINT	Null	Empty

Refer to the EtherNet/IP specification for more information.

13. CIP objects

13. 7. Motor data object

The Motor data object acts as a motor parameter database.

Class code

Hexadecimal	Decimal
16#28	40

Object 28hex (Motor Data)

Path	CIP name	CIP configuration parameter name
16#28/01/06 = 40/1/6	RatedCurrent	Motor Rated Cur
16#28/01/07 = 40/1/7	RatedVoltage	Motor Rated Volt
16#28/01/09 = 40/1/9	RatedFreq	Motor Rated Freq
16#28/01/0F = 40/1/15	BaseSpeed	Motor Base Speed

Telemecanique adaptation:

Path	Code	Altivar name	Logic address
16#28/01/06 = 40/1/6	NCR	Rated mot. current	16#2583 = 9603
16#28/01/07 = 40/1/7	UNS	Rated motor volt.	16#2581 = 9601
16#28/01/09 = 40/1/9	FRS	Rated motor freq.	16#2582 = 9602
16#28/01/0F = 40/1/15	NSP	Rated motor speed	16#2584 = 9604

Class attributes

Attribute ID	Access	Name	Need	Data type	Value	Details
1	Get	Revision	Opt.	UINT	2	—
2	Get	Max instance	Opt.	UINT	1	—
6	Get	Max ID number of class attribute	Opt.	UINT	7	—
7	Get	Max ID number of instance attribute	Opt.	UINT	15	—

Instance attributes

Attribute ID	Access	Name	Need	Data type	Value	Details
3	Get/Set	MotorType	Req.	USINT	7	6 = Wound rotor induction motor 7 = Squirrel cage induction motor
6	Get/Set	RatedCurrent	Req.	UINT	Determined by the drive controller rating	[Rated mot. current] (<i>n C r</i>)
7	Get/Set	RatedVoltage	Req.	UINT	Determined by the drive controller rating	[Rated mot. volt.] (<i>U n S</i>)
9	Get/Set	RatedFreq	Opt.	UINT	50/60	[Rated motor freq.] (<i>F r S</i>)
15	Get/Set	BaseSpeed	Opt.	UINT	Determined by the drive controller rating	[Nom motor speed] (<i>n S P</i>)

Class service

Service code	Service name	Need	Description
16#0E	Get_Attribute_Single	Req.	Read an attribute

Instance service

Service code	Service name	Need	Description
16#0E	Get_Attribute_Single	Req.	Read an attribute
16#10	Set_Attribute_Single	Opt.	Write an attribute

13. CIP objects

13.8. Control supervisor object

The Control supervisor object models the functions for managing devices within the hierarchy of motor control devices.

Object 29hex (Control Supervisor)

Path	CIP name	CIP configuration parameter name
16#29/01/0D = 41/1/13	FaultCode	Fault Code

Telemecanique adaptation:

Path	Code	Altivar name	Logic address
16#29/01/0D = 41/1/13	ERRD	CiA402 fault code	16#219E = 8606

Class code

Hexadecimal	Decimal
16#29	41

Class attributes

Attribute ID	Access	Name	Need	Data type	Value	Details
1	Get	Revision	Optional	UINT	2	—
2	Get	Max instance	Optional	UINT	1	—
6	Get	Max ID number of class attribute	Optional	UINT	7	—
7	Get	Max ID number of instance attribute	Optional	UINT	17	—

Instance attributes

Attribute ID	Access	Name	Need	Data type	Details
3	Get/Set	Run Fwd	Required	BOOL	On an edge (0 →1)
4	Get/Set	Run Rev	Optional	BOOL	On an edge (0 →1)
5	Get/Set	NetCtrl	Optional	BOOL	0: Local Control (Channel 1) 1: Network Control (default)
6	Get	State	Optional	USINT	0 = Vendor Specific, 1 = Startup, 2 = Not_Ready, 3 = Ready, 4 = Enabled, 5 = Stopping, 6 = Fault_Stop, 7 = Drive detected fault
7	Get	Running Fwd	Required	BOOL	
8	Get	Running Rev	Optional	BOOL	
9	Get	Ready	Optional	BOOL	
10	Get	Faulted	Required	BOOL	
12	Get/Set	FaultRst	Required	BOOL	Clear detected fault (0 →1)
13	Get	FaultCode	Optional	UINT	Refer to the Communication parameters manual: DSP402 fault code (Errd)
15	Get	CtrlFromNet	Optional	BOOL	0 = Local Control; 1 = Network Control

13. CIP objects

Class service

Service Code	Service name	Need	Description
16#0E	Get_Attribute_Single	Required	Read an attribute

Instance service

Service Code	Service name	Need	Description
16#0E	Get_Attribute_Single	Required	Read an attribute
16#10	Set_Attribute_Single	Required	Write an attribute
16#05	Reset	Required	Drive reset

Control supervisor state transition diagram

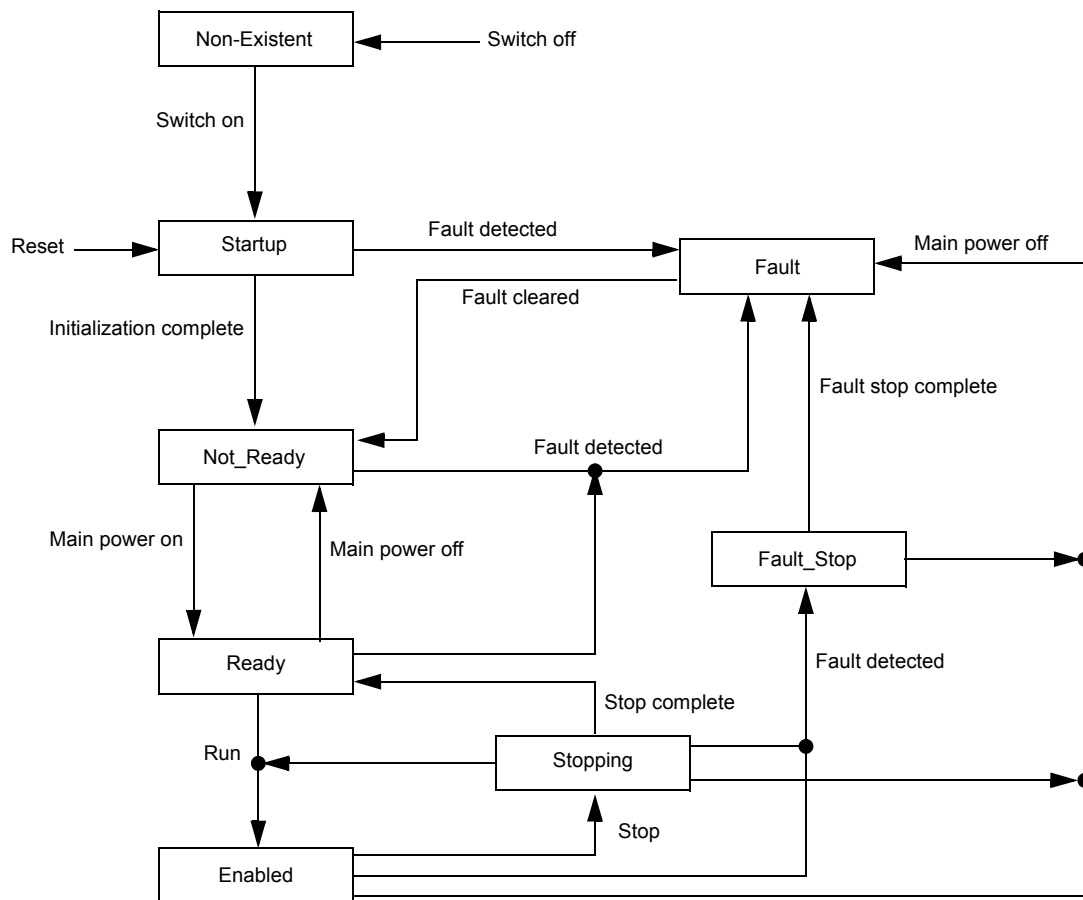

13. CIP objects

13.9. AC/DC Drive Object

The AC/DC Drive object models the drive controller functions such as torque control and speed ramp.

Class code

Hexadecimal	Decimal
16#2A	42

Class attributes

Attribute ID	Access	Name	Need	Data Type	Value	Details
1	Get	Revision	Optional	UINT	1	—
2	Get	Max instance	Optional	UINT	1	—
6	Get	Max ID number of class attribute	Optional	UINT	7	—
7	Get	Max ID number of instance attribute	Optional	UINT	21	—

Instance attributes

Attribute ID	Access	Name	Need	Data type	Details
3	Get	AtReference	Optional	BOOL	
4	Get/Set	NetRef (1)	Required	BOOL	0: Local speed setpoint (AI1 or AI2) 1: Speed setpoint via the network
5	Get/Set	NetProc	Optional	BOOL	Not handled
6	Get/Set	Drive mode	Required	USINT	1: Open loop 2: Closed loop (FVC)
7	Get	SpeedActual	Required	INT	Output speed (rFrd)
8	Get/Set	SpeedRef	Required	INT	Speed setpoint (LFrd)
9	Get	CurrentActual	Optional	INT	Motor current (LCr)
10	Get/Set	CurrentLimit	Optional	INT	[Mot. therm. current] (lth)
11	Get	TorqueActual	Optional	INT	Output torque (Otrn)
12	Get/Set	TorqueRef	Optional	INT	Torque setpoint (LtCr)
18	Get/Set	AccelTime	Optional	UINT	Acceleration time (ACCd)
19	Get/Set	DecelTime	Optional	UINT	Deceleration time (dECd)
20	Get/Set	LowSpdLimit	Optional	UINT	Parameter [Low speed] (LSP) converted in RPM
21	Get/Set	HighSpdLimit	Optional	UINT	Parameter [High speed] (HSP) converted in RPM

Class service

Service code	Service name	Need	Description
16#0E	Get_Attribute_Single	Required	Read an attribute

Instance service

Service code	Service name	Need	Description
16#0E	Get_Attribute_Single	Required	Read an attribute
16#10	Set_Attribute_Single	Optional	Write an attribute

13. CIP objects

13. 10. Assembly object

The Assembly object binds together the attributes of multiple objects so that information to or from each object can be communicated over a single connection.

Assembly objects are static.

The assemblies in use can be modified through the network configuration tool (RSNetWorx) parameter access.

Power to the drive controller must be cycled for the new assembly assignments to be effective.

Class code

Hexadecimal	Decimal
16#04	4

Class attribute

Attribute ID	Access	Name	Need	Data type	Value	Details
1	Get	Revision	Optional	UINT	2	—
2	Get	Max instance	Optional	UINT	105	13 defined instances

Instances supported

Instance	Name	Data size
20	ODVA Basic speed control output	4 bytes
21	ODVA Extended speed control output	4 bytes
22	ODVA Speed and torque control output	6 bytes
23	ODVA Extended speed and torque control output	6 bytes
100	Native drive output	16 bytes
103	Allen-Bradley [®] drive output	20 bytes
70	ODVA Basic speed control input	4 bytes
71	ODVA Extended speed control input	4 bytes
72	ODVA Speed and torque control input	6 bytes
73	ODVA Extended speed and torque control input	6 bytes
101	Native drive input	16 bytes
104	Allen-Bradley [®] drive input	20 bytes

The description of each instance is detailed in chapter [15. Device profiles](#)

Instance attributes

Attribute ID	Access	Name	Need	Data type	Value	Details
3	Get/Set (1)	Data	Required			

(1) Set access is restricted to output instances only (instances 20, 21, 22, 23, 100 and 103).

Class service

Service code	Service name	Need	Description
16#0E	Get_Attribute_Single	Required	Read an attribute

Instance service

Service code	Service name	Need	Description
16#0E	Get_Attribute_Single	Required	Read an attribute
16#10	Set_Attribute_Single	Optional	Write an attribute

13. CIP objects

13. 11. Application objects

Class code

Hexadecimal	Decimal
16#70 to 16#A8	112 to 424

Altivar parameters path

The Altivar parameters are grouped in classes.
Each application class has only 1 instance.
Each instance groups 200 parameters.
Each attribute in an instance relates to a parameter.

The first parameter registered in the first application class (class code: 16#70 = 112) has the logical address 3000.

Examples:

Logical address	Path Hexadecimal	Path decimal
3 000	16# 70 / 01 / 01	112 / 1 / 1
3 100	16# 70 / 01 / 65	112 / 1 / 101
3 200	16# 71 / 01 / 01	113 / 1 / 1
64 318	16# A2 / 1 / 77	418 / 1 / 119

Refer to the Communication parameters manual.

Class attributes

Attribute ID	Access	Name	Need	Data type	Value
1	Get	Revision	Optional	UINT	1
2	Get	Max instance	Optional	UINT	1
6	Get	Max ID number of class attribute	Optional	UINT	7
7	Get	Max ID number of instance attribute	Optional	UINT	X

Instance attributes

Attribute ID	Access	Name	Data type	Value
1	Get/Set	First parameter of the class	UINT / USINT	Value returned by the drive controller
...
X	Get/Set	Last parameter of the class	UINT / USINT	Value returned by the drive controller

Note: Certain parameters do not have write access. Refer to the Communication parameters manual for more information.

Class service

Service code	Service name	Need	Description
16#0E	Get_Attribute_Single	Required	Read an attribute

Instances service

Service code	Service name	Need	Description
16#0E	Get_Attribute_Single	Required	Read an attribute
116#0	Set_Attribute_Single	Optional	Write an attribute

13. CIP objects

■ Object 2Ahex (AC/DC Drive)

Path	CIP name	CIP configuration parameter name
16#2A/01/07 = 42/1/7	SpeedActual	Speed Actual
16#2A/01/08 = 42/1/8	SpeedRef	Speed Reference
16#2A/01/09 = 42/1/9	CurrentActual	Current Actual
16#2A/01/0A = 42/1/10	CurrentLimit	Current Limit
16#2A/01/0B = 42/1/11	TorqueActual	Torque Actual
16#2A/01/0C = 42/1/12	TorqueRef	Torque Reference
16#2A/01/12 = 42/1/18	AccelTime	Accel Time
16#2A/01/13 = 42/1/19	DecelTime	Decel Time
16#2A/01/14 = 42/1/20	LowSpdLimit	Low Speed Limit
16#2A/01/15 = 42/1/21	HighSpdLimit	High Speed Limit

Telemecanique adaptation:

Path	Code	Altivar name	Logic address	Unit Id
16#2A/01/07 = 42/1/7	RFRD	Output velocity	16#219C = 8604	
16#2A/01/08 = 42/1/8	LFRD	Speed setpoint	16#219A = 8602	
16#2A/01/09 = 42/1/9	LCR	Motor current	16#0C84 = 3204	
16#2A/01/0A = 42/1/10	ITH	Mot. therm. current	16#2596 = 9622	
16#2A/01/0B = 42/1/11	Otrn	Output torque (Nm)	16#2A0B = 10763	251
16#2A/01/0C = 42/1/12	n.a.	Torque setpoint (Nm)	16#2A0C = 10764	251
16#2A/01/12 = 42/1/18	ACCD	CIP acceleration time	16#2A12 = 10770	251
16#2A/01/13 = 42/1/19	DECD	CIP deceleration time	16#2A13 = 10771	251
16#2A/01/14 = 42/1/20	LSPD	CIP Low speed limit	16#2A14 = 10772	251
16#2A/01/15 = 42/1/21	HSPD	CIP High speed limit	16#2A15 = 10773	251

14. Explicit Messaging

The following figure shows an example of explicit messaging: The value of the ACC parameter (Modbus @ = 9001 / CIP address 16#2A:1:16#12) is modified when the variable "bit01" is toggled On.

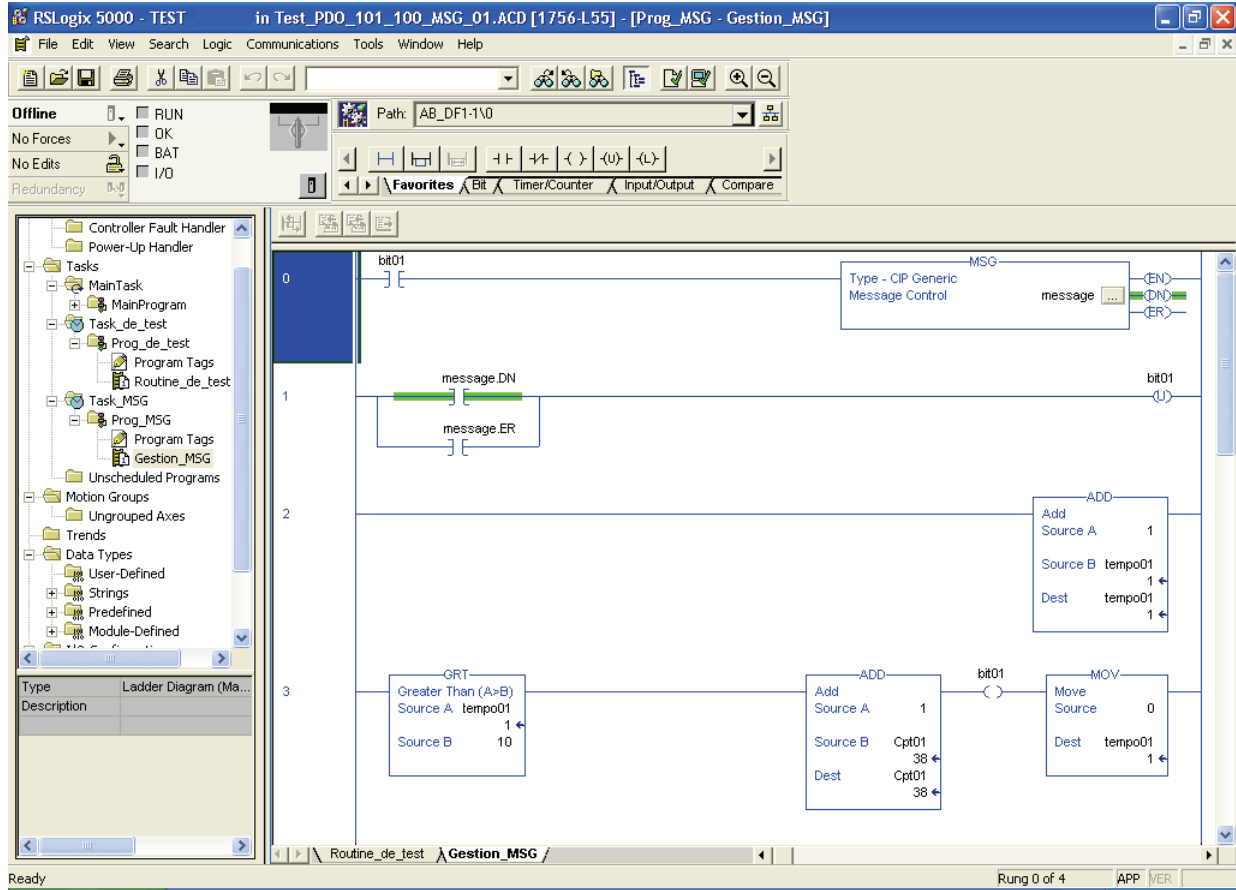

The following figure shows the Message Configuration window in detail.

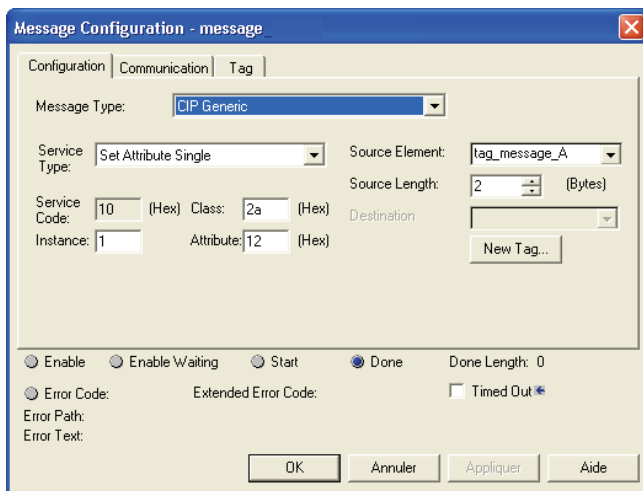

15. Device profiles

The EtherNet/IP card provides several profiles:

- CIP AC drive profile (0x02) (default setting)
- Allen-Bradley® drive profile
- Telemecanique: CiA 402 and I/O

The profile is chosen by selecting the appropriate input and output assemblies.

“Integration in RSLogix,” beginning on page 35 of this manual, describes how to select the assemblies.

■ List of assemblies

Output assemblies

Assembly name	Number	Size
CIP basic speed control output	20	2 words (4 bytes)
CIP extended speed control output	21	2 words (4 bytes)
CIP speed and torque control output	22	3 words (6 bytes)
CIP extended speed and torque control output	23	3 words (6 bytes)
Native drive output	100	2 to 10 words (4 to 20 bytes)
Allen-Bradley® drive output	103	2 to 10 words (4 to 20 bytes)

Input assemblies

Assembly name	Number	Size
CIP basic speed control input	70	2 words (4 bytes)
CIP extended speed control input	71	2 words (4 bytes)
CIP speed and torque control input	72	3 words (6 bytes)
CIP extended speed and torque control input	73	3 words (6 bytes)
Native drive input	101	2 to 10 words (4 to 20 bytes)
Allen-Bradley® drive input	104	2 to 10 words (4 to 20 bytes)

IMPORTANT REMARK:

For the assemblies 20 and 22, the default settings define that the speed setpoint comes from the terminals. To fully control the drive controller from the network, object 2A/1/4 (netref) must be changed from 0 to 1 (byte). This assignment can be accomplished:

- By a program, with an MSG() instruction block, or
- With the Class Instance Editor

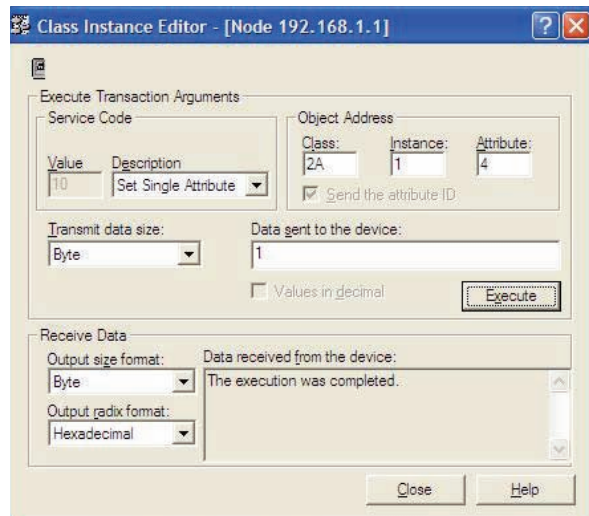

15. Device profiles

■ Assembly 20: CIP basic speed control output

Assembly mapping

Word number	Definition
0	CIP basic command word
1	Speed setpoint (rpm)

CIP basic command word

Bit 7	Bit 6	Bit 5	Bit 4	Bit 3	Bit 2	Bit 1	Bit 0
Not used	Not used	Not used	Not used	Not used	Fault clear (1) 0 = No command 1 = Fault clear	Not used	Run Forward (2) 0 = Stop 1 = Run

(1) Active on rising edge.

(2) Active on level.

Bit 15	Bit 14	Bit 13	Bit 12	Bit 11	Bit 10	Bit 9	Bit 8
Not used	Not used	Not used	Not used	Not used	Not used	Not used	Not used

■ Assembly 70: CIP basic speed control input

Assembly mapping

Word number	Definition
0	CIP basic status word
1	Actual speed (rpm)

CIP basic status word

Bit 7	Bit 6	Bit 5	Bit 4	Bit 3	Bit 2	Bit 1	Bit 0
Not used	Not used	Not used	Not used	Not used	Running 0 = Stopped 1 = Running	Not used	Fault status 0 = No fault 1 = Fault

Bit 15	Bit 14	Bit 13	Bit 12	Bit 11	Bit 10	Bit 9	Bit 8
Not used	Not used	Not used	Not used	Not used	Not used	Not used	Not used

■ Assembly 21: CIP extended speed control output

Assembly mapping

Word number	Definition
0	CIP extended command word
1	Speed setpoint (rpm)

CIP extended command word

Bit 7	Bit 6	Bit 5	Bit 4	Bit 3	Bit 2	Bit 1	Bit 0
Not used	Network setpoint 0 = Setpoint by terminals 1 = Setpoint by network	Network command 0 = Command by terminals 1 = Command by network	Not used	Not used	Fault clear (1) 0 = No command 1 = Fault clear	Run forward / reverse 00 = Quick stop 01 = Run forward 10 = Run reverse 11 = Freewheel stop	

Bit 15	Bit 14	Bit 13	Bit 12	Bit 11	Bit 10	Bit 9	Bit 8
Not used	Not used	Not used	Not used	Not used	Not used	Not used	Not used

(1) Active on rising edge.

15. Device profiles

■ Assembly 71: CIP extended speed control input

Assembly mapping

Word number	Definition
0	CIP extended status word
1	Actual speed (rpm)

CIP extended status word

Bit 7	Bit 6	Bit 5	Bit 4	Bit 3	Bit 2	Bit 1	Bit 0
At reference 0 = Reference not reached 1 = Reference reached	Setpoint from network 0 = Setpoint from terminals 1 = Setpoint from network	Command from network 0 = Command from terminals 1 = Command from network	Ready 0 = Not ready 1 = Ready	Running forward / reverse 00 = Stopped 01 = Running forward 10 = Running reverse 11 = Not used	Alert signal 0 = No alert signal 1 = Alert signal	Not used	
Bit 15	Bit 14	Bit 13	Bit 12	Bit 11	Bit 10	Bit 9	Bit 8
Not used	Not used	Not used	Not used	Not used	Bit 8 to bit 10 are used for the drive controller state 000 = Not used 001 = Startup 010 = Not ready 011 = Ready 100 = Enabled 101 = Stopping 110 = Fault stop 111 = Drive detected fault		

■ Assembly 22: CIP speed and torque control output

Assembly mapping

Word number	Definition
0	CIP basic command word (1)
1	Speed setpoint (rpm)
2	Torque setpoint (Nm)

(1) Refer to assembly 20.

■ Assembly 72: CIP speed and torque control input

Assembly mapping

Word number	Definition
0	CIP basic status word (1)
1	Actual speed (rpm)
2	Actual torque (Nm)

(1) Refer to assembly 70.

■ Assembly 23: CIP extended speed and torque control output

Assembly mapping

Word number	Definition
0	CIP extended command word (1)
1	Speed setpoint (rpm)
2	Torque setpoint (Nm)

(1) Refer to assembly 21.

15. Device profiles

■ Assembly 73: CIP extended speed and torque control input

Assembly mapping

Word number	Definition
0	CIP extended status word (1)
1	Actual speed (rpm)
2	Actual torque (Nm)

(1) Refer to assembly 71.

■ Assembly 100: Native drive output

Assembly mapping

Word number	Definition
0	Control word
1	Velocity setpoint
2	Scanner write word 1
3	Scanner write word 2
4	Scanner write word 3
5	Scanner write word 4
6	Scanner write word 5
7	Scanner write word 6

Altivar 71/61 assignment

Word number	Code	Name	Logic address
0	NC1	Communication scanner, value of write word 1 (default value: CMD, Control word)	16#31D9 = 12761
1	NC2	Communication scanner, value of write word 2 (default value: LFRD, velocity setpoint)	16#31DA = 12762
2	NC3	Communication scanner, value of write word 3	16#31DB = 12763
3	NC4	Communication scanner, value of write word 4	16#31DC = 12764
4	NC5	Communication scanner, value of write word 5	16#31DD = 12765
5	NC6	Communication scanner, value of write word 6	16#31DE = 12766
6	NC7	Communication scanner, value of write word 7	16#31DF = 12767
7	NC8	Communication scanner, value of write word 8	16#31E0 = 12768

Note: The default assignment of NC1 and NC2 must be changed to "Not assigned".

15. Device profiles

■ Assembly 101: Native drive input

Assembly mapping

Word number	Definition
0	Scanner read word 1
1	Scanner read word 2
2	Scanner read word 3
3	Scanner read word 4
4	Scanner read word 5
5	Scanner read word 6
6	Scanner read word 7
7	Scanner read word 8

Altivar 71/61 assignment

Word number	Code	Name	Logic address
0	NM1	Communication scanner, value of read word 1 (default value: Status word, ETA)	16#31C5 = 12741
1	NM2	Communication scanner, value of read word 2 (default value: Velocity actual value, RFRD)	16#31C6 = 12742
2	NM3	Communication scanner, value of read word 3	16#31C7 = 12743
3	NM4	Communication scanner, value of read word 4	16#31C8 = 12744
4	NM5	Communication scanner, value of read word 5	16#31C9 = 12745
5	NM6	Communication scanner, value of read word 6	16#31CA = 12746
6	NM7	Communication scanner, value of read word 7	16#31CB = 12747
7	NM8	Communication scanner, value of read word 8	16#31CC = 12748

15. Device profiles

■ Assembly 103: Allen-Bradley® drive output

Assembly mapping

Word number	Definition
0	Allen-Bradley® drive logic command
1	Standardized speed setpoint (reference)
2	Scanner write word 1
3	Scanner write word 2
4	Scanner write word 3
5	Scanner write word 4
6	Scanner write word 5
7	Scanner write word 6
8	Scanner write word 7
9	Scanner write word 8

Altivar 71/61 assignment

Word number	Code	Name	Logic address
0	n.a.	Allen-Bradley® drive logic command	n.a.
1	LFR	Frequency setpoint	16#2136 = 8502
2	NC1	Communication scanner, value of write word 1	16#31D9 = 12761
3	NC2	Communication scanner, value of write word 2	16#31DA = 12762
4	NC3	Communication scanner, value of write word 3	16#31DB = 12763
5	NC4	Communication scanner, value of write word 4	16#31DC = 12764
6	NC5	Communication scanner, value of write word 5	16#31DD = 12765
7	NC6	Communication scanner, value of write word 6	16#31DE = 12766
8	NC7	Communication scanner, value of write word 7	16#31DF = 12767
9	NC8	Communication scanner, value of write word 8	16#31E0 = 12768

Note: The default assignment of NC1 and NC2 must be changed to another value or to not assigned.

15. Device profiles

■ Allen-Bradley® drive logic command

The logic command is a 16-bit control word produced by the scanner and consumed by the EtherNet/IP card.

If enabled, the logic command word is word 0 in the output image.

Bit 7	Bit 6	Bit 5 Bit 4	Bit 3	Bit 2	Bit 1	Bit 0
MOP Increment 0 = Not Increment 1 = Increment	Local control 0 = No local control 1 = Local control	Direction 00 = No command (4) 01 = Forward command 10 = Reverse command 11 = Hold direction control	Clear faults (3) 0 = Not clear faults 1 = Clear faults	Jog 0 = Not jog 1 = Jog	Start (2) 0 = Not start 1 = Start	Stop (1) 0 = Not stop 1 = Stop

Bit 15	Bit 14	Bit 13	Bit 12	Bit 11 Bit 10	Bit 9 Bit 8
MOP Decrement 0 = Not decrement 1 = Decrement	Reference select 000 = No command (7) 001 = Setpoint 1 channel (Fr1) 010 = Setpoint 2 channel (Fr2) 011 = Ref. 3 (Preset 3) 100 = Ref. 4 (Preset 4) 101 = Ref. 5 (Preset 5) 110 = Ref. 6 (Preset 6) 111 = Ref. 7 (Preset 7)			Decel rate 00 = No command (6) 01 = Decel rate 1 command 10 = Decel rate 2 command 11 = Hold decel rate	Accel rate 00 = No command (5) 01 = Accel rate 1 command 10 = Accel rate 2 command 11 = Hold accel rate

- (1) Stop: Active at level.
- (2) Start: Active on rising edge. A Not Stop condition (logic 0 = 0) must first be present before a Start condition (logic 1 = 1) will start the drive controller.
- (3) Clear faults: Active on rising edge. To perform this command, the value must switch from "0" to "1."
- (4) Direction \ No command: If a direction is selected, acts like Hold direction control.
- (5) Accel rate \ No command: If a rate is selected, acts like Hold accel rate.
- (6) Decel rate \ No command: If a rate is selected, acts like Hold decel rate.
- (7) Reference select \ No command: If a rate is selected, acts like Hold command.

■ Altivar 71/61 assignment

Bit 7	Bit 6	Bit 5 Bit 4	Bit 3	Bit 2	Bit 1	Bit 0
Not used	Not used	Direction 00 = No command (4) 01 = Forward command 10 = Reverse command 11 = Hold direction control	Clear faults (3) 0 = Not clear faults 1 = Clear faults	Not used	Start (2) 0 = Not start 1 = Start	Stop (1) 0 = Not stop 1 = Stop

Bit 15	Bit 14	Bit 13	Bit 12	Bit 11	Bit 10	Bit 9	Bit 8
Not used	Setpoint select 000 = No command 001 = Terminals 010 = Control by network 011 = Preset 3 100 = Preset 4 101 = Preset 5 110 = Preset 6 111 = Preset 7			Not used	Not used	Not used	Not used

- (1) Stop: Active at level.
- (2) Start: Active on rising edge. A Not Stop condition (logic 0 = 0) must first be present before a Start condition (logic 1 = 1) will start the drive controller.
- (3) Clear faults: Active on rising edge. To perform this command, the value must switch from "0" to "1."
- (4) Direction \ No command: If a direction is selected, acts like Hold direction control.

15. Device profiles

■ Standardized setpoint

The setpoint (16 bits only) is produced by the controller and consumed by the EtherNet/IP card.

If enabled, the setpoint is word 1 in the output image.

The setpoint value is a standardized (scaled) value; it is not an engineering value.

Telemecanique adaptation

[Frequency setpoint] (*L F r*) is configured in high resolution: standardized value on 16 signed bits at maximum frequency. The value 32767 corresponds to the parameter [Max frequency] (*LFr*). The default value of the parameter [Max frequency] (*LFr*) is 60 Hz, and the resolution is approximately 0.0018 Hz.

Note:

The commanded maximum speed can never exceed the value of parameter [High speed] (HSP).

The table below shows example setpoints and their results on an Altivar drive controller that has its parameter [Max frequency] (*LFr*) set to 130 Hz and its parameter [High speed] (*HSP*) set to 60 Hz.

Setpoint value	Scale		Output speed	Feedback value
	Percent	Value		
32767 (1)	100%	130 Hz	60 Hz (2)	15123 (3)
16384	50%	65 Hz	60 Hz (2)	15123 (3)
8192	25%	32.5 Hz	32.5 Hz	8192
0	0%	0 Hz	0 Hz	0

(1) A value of 32767 is equivalent to the parameter [Max frequency] (*LFr*) frequency value. Values greater than 32767 reverse speed.

(2) The drive controller runs at 60 Hz instead of 130 Hz or 65 Hz because the parameter [High speed] (*HSP*) sets 60 Hz as the maximum speed.

(3) The feedback value is also scaled based on the value of the parameter [Max frequency] (*LFr*), for example, $60/130 = 0.46$ so $32767 \times 0.46 = 15123$.

■ Assembly 104: Allen-Bradley® drive input

Assembly mapping

Word number	Definition
0	Allen-Bradley® drive logic status
1	Speed feedback (actual value)
2	Scanner read word 1
3	Scanner read word 2
4	Scanner read word 3
5	Scanner read word 4
6	Scanner read word 5
7	Scanner read word 6
8	Scanner read word 7
9	Scanner read word 8

Word number	Code	Name	Logic address
0	n.a.	Allen-Bradley® drive logic status	n.a.
1	RFR	Output frequency	16#0C82 = 3202
2	NM1	Communication scanner, value of read word 1	16#31C5 = 12741
3	NM2	Communication scanner, value of read word 2	16#31C6 = 12742
4	NM3	Communication scanner, value of read word 3	16#31C7 = 12743
5	NM4	Communication scanner, value of read word 4	16#31C8 = 12744
6	NM5	Communication scanner, value of read word 5	16#31C9 = 12745
7	NM6	Communication scanner, value of read word 6	16#31CA = 12746
8	NM7	Communication scanner, value of read word 7	16#31CB = 12747
9	NM8	Communication scanner, value of read word 8	16#31CC = 12748

Note: The default assignment of NM1 and NM2 must be changed to "Not assigned."

15. Device profiles

■ Allen-Bradley® drive logic status

Logic Status is a 16-bit status word produced by the EtherNet/IP card and consumed by the scanner.
If enabled, Logic Status is word 2 in the input image.

Bit 7	Bit 6	Bit 5	Bit 4	Bit 3	Bit 2	Bit 1	Bit 0
Fault	Alarm	Decelerating	Accelerating	Actual direction	Command direction	Active	Ready
0 = No fault 1 = Fault	0 = No alarm 1 = Alarm	0 = Not decelerating 1 = Decelerating	0 = Not accelerating 1 = Accelerating	0 = Reverse 1 = Forward	0 = Reverse 1 = Forward	0 = Not active 1 = Active	0 = Not ready 1 = Ready

Bit 15	Bit 14	Bit 13	Bit 12	Bit 11	Bit 10	Bit 9	Bit 8
Reference				Local control		At speed	
0000 = Ref A auto 0001 = Ref B auto 0010 = Preset 2 auto 0011 = Preset 3 auto 0100 = Preset 4 auto 0101 = Preset 5 auto 0110 = Preset 6 auto 0111 = Preset 7 auto 1000 = Term blk manual 1001 = DPI 1 manual 1010 = DPI 2 manual 1011 = DPI 3 manual 1100 = DPI 4 manual 1101 = DPI 5 manual 1110 = DPI 6 manual 1111 = Jog reference				000 = Port 0 (TB) 001 = Port 1 010 = Port 2 011 = Port 3 100 = Port 4 101 = Port 5 110 = Port 6 111 = No local		0 = Not at reference 1 = At reference	

Telemecanique adaptation

Bit 7	Bit 6	Bit 5	Bit 4	Bit 3	Bit 2	Bit 1	Bit 0
Detected Fault	Alarm	Decelerating	Accelerating	Actual direction	Command direction	Running	Ready
0 = No detected fault 1 = Detected fault	0 = No alarm 1 = Alarm	0 = Not decelerating 1 = Decelerating	0 = Not accelerating 1 = Accelerating	0 = Reverse 1 = Forward	0 = Reverse 1 = Forward	0 = Not active 1 = Active	0 = Not ready 1 = Read

Bit 15	Bit 14	Bit 13	Bit 12	Bit 11	Bit 10	Bit 9	Bit 8
Setpoint source				Control source		At speed	
0000 = Terminals 0001 = not used 0010 = Preset 2 0011 = Preset 3 0100 = Preset 4 0101 = Preset 5 0110 = Preset 6 0111 = Preset 7 1000 = not used 1001 = Graphic display terminal 1010 = Modbus 1011 = CANopen 1100 = PowerSuite 1101 = EtherNet/IP card 1110 = Controller inside 1111 = not used				000 = Terminals 001 = Graphic display terminal 010 = Modbus 011 = CANopen 100 = PowerSuite 101 = EtherNet/IP card 110 = Controller inside 111 = not used		0 = Not at reference 1 = At reference	

Note: When the value of Setpoint source (bits 12, 13, 14, and 15) is Preset speed x, it means that the corresponding command is given by assembly 103 via Setpoint select (bits 12, 13, and 14) and not by the terminals.

16. Configuring an ATV71/61 drive to replace a Powerflex® drive

This chapter illustrates how to exchange a Powerflex® drive with an ATV71 drive controller. There are three ways to configure a drive controller equipped with an EtherNet/IP card. This example uses RSLogix® software.

IMPORTANT NOTE:

The ATV71/61 drive controller provides several assembly sets. Assemblies 103 and 104 emulate Powerflex drive assemblies 1 and 2. For compatibility, these assemblies are interchangeable. This means that in the ATV71/61:

- output assemblies 103 and 2 are identical and
- input assemblies 104 and 1 are identical.

In the following example assumes a network consisting of a single Powerflex drive. It describe how to replace the Powerflex drive with an ATV71 drive controller.

The screenshot shows the RSLogix 5000 software interface. The main window displays a table of tags for the controller. The table has columns for Tag Name, Value, and Description. The tags are organized into sections: Powerflex:I.Data, Powerflex:O, and Powerflex:O.Data. The status window at the bottom shows a message: "Going online with controller... Complete - 0 error(s), 0 warning(s)".

Tag Name	Value	Description
Powerflex:I.Data[0]	0	
Powerflex:I.Data[1]	0	
Powerflex:I.Data[2]	3596	Allen Bradley drive logic status
Powerflex:I.Data[3]	0	actual speed
Powerflex:I.Data[4]	2	IO scanning word 1
Powerflex:I.Data[5]	15	IO scanning word 2
Powerflex:I.Data[6]	880	IO scanning word 3
Powerflex:I.Data[7]	100	IO scanning word 4
Powerflex:I.Data[8]	2	IO scanning word 5
Powerflex:I.Data[9]	15	IO scanning word 6
Powerflex:I.Data[10]	880	IO scanning word 7
Powerflex:I.Data[11]	100	IO scanning word 8
Powerflex:O	{...}	
Powerflex:O.Data	{...}	
Powerflex:O.Data[0]	8192	Allen Bradley drive logic command
Powerflex:O.Data[1]	2000	Speed reference
Powerflex:O.Data[2]	2	Io Scanning Word 1
Powerflex:O.Data[3]	0	Io Scanning Word 2
Powerflex:O.Data[4]	0	Io Scanning Word 3
Powerflex:O.Data[5]	0	Io Scanning Word 4
Powerflex:O.Data[6]	0	Io Scanning Word 5
Powerflex:O.Data[7]	0	Io Scanning Word 6
Powerflex:O.Data[8]	0	Io Scanning Word 7
Powerflex:O.Data[9]	0	Io Scanning Word 8

16. Configuring an ATV71/61 drive to replace a Powerflex® drive

Place the RSLogix environment Offline as shown below.

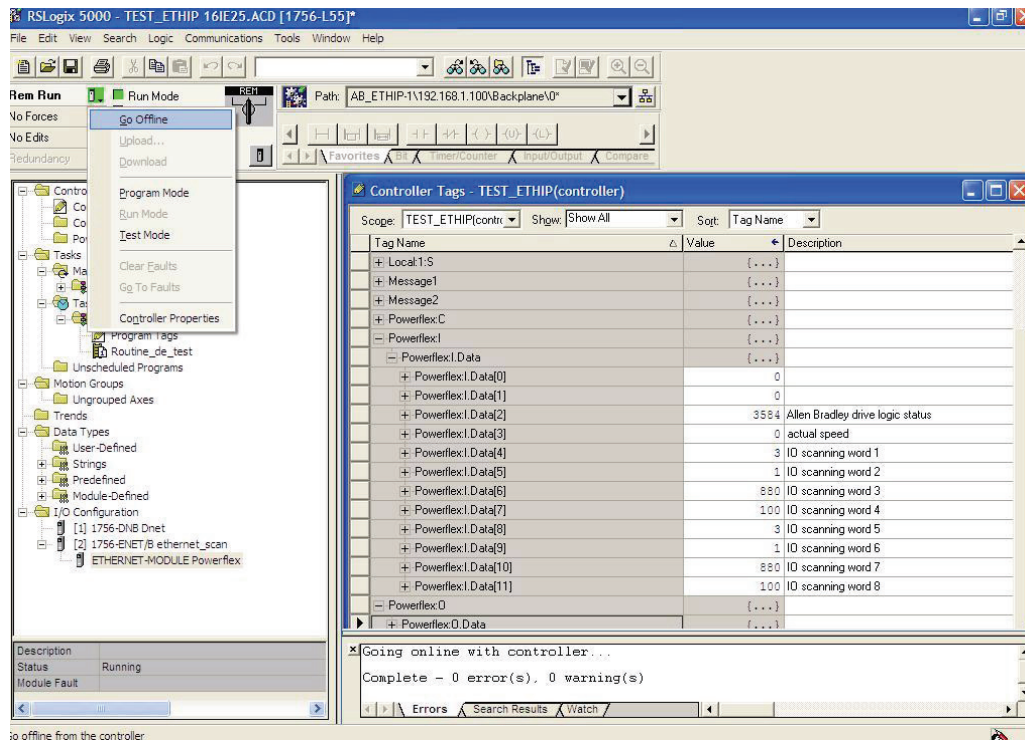

Then edit the module properties of the ethernet module Powerflex by double-clicking in the navigation tree.

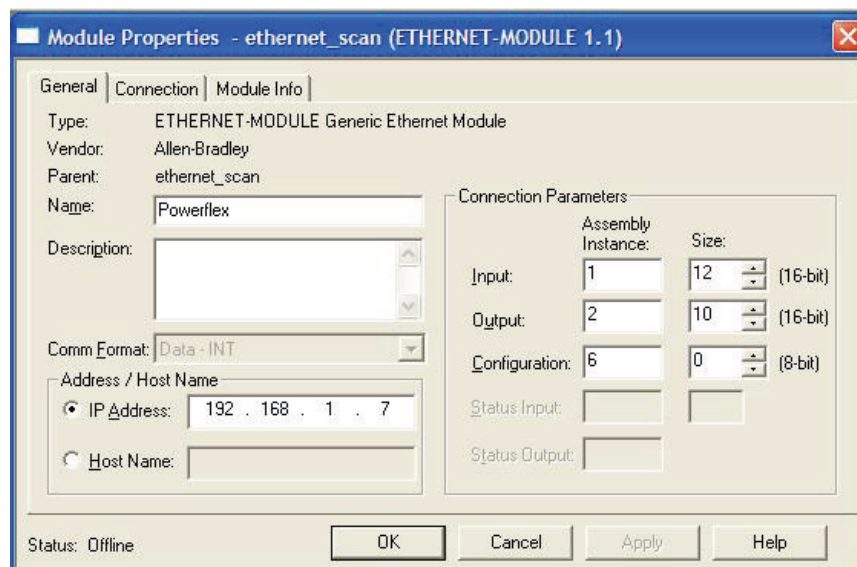

16. Configuring an ATV71/61 drive to replace a Powerflex® drive

Notice that only the Module Name is changed.

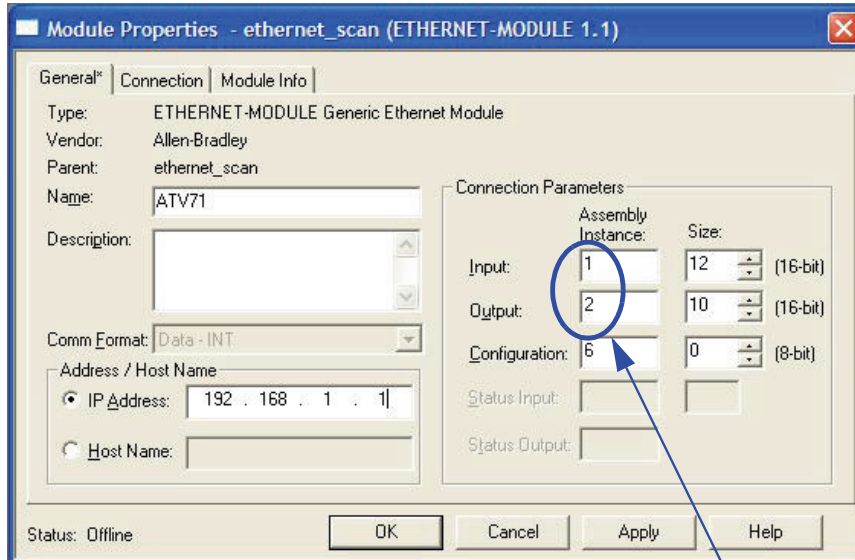

Assemblies 1 and 2 are used for the Powerflex drive.

But Assemblies 103 and 104 could also be used, as shown below.

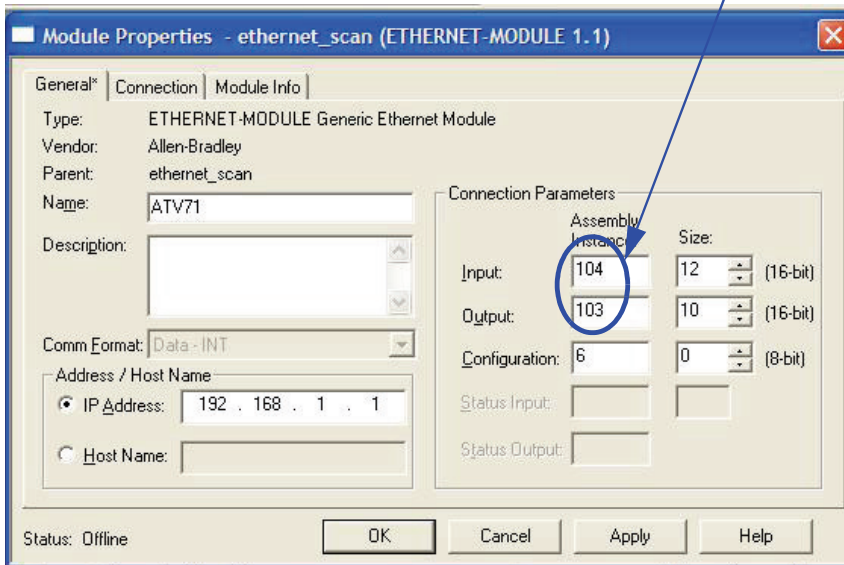

Confirm the modification by clicking OK, save the project, and download it to the PLC.

16. Configuring an ATV71/61 drive to replace a Powerflex® drive

Now, switch to RSnetworx, The old configuration is displayed:

The screenshot shows the RSNetWorx for EtherNet/IP interface. The 'Device Usage' section is active, displaying a table of device statistics:

Worst Case Device Usages	Address	Pending	Connection:	Address	Pending	Devices not included:	Pending
Minimum CPU:	192.168.1.100	0.04%	192.168.1.100	192.168.1.100	0.78%	1	
Maximum CPU:	192.168.1.100	0.04%	Consume:				
			Produce:				

The 'Hardware' section shows a tree view of the network configuration. The 'PowerFlex 70' drive is highlighted, with its IP address 192.168.1.100. The 'Messages' section shows a log of events:

Message Code	Date	Description
ENET:81E7	12/09/2007 11:13:15	Edits enabled.
ENET:81E4	12/09/2007 10:45:46	Mode changed to online. The communication timeout is 3000 msec. The online path is W\XFR63469D\AB_ETH-IP-1.
ENET:81E5	12/09/2007 10:45:45	Mode changed to offline.
ENET:81E4	12/09/2007 10:24:32	Mode changed to online. The communication timeout is 3000 msec. The online path is W\XFR63469D\AB_ETH-IP-1.

Browse the whole network:

The screenshot shows the RSNetWorx for EtherNet/IP interface with the 'Browse network...' dialog box open. The dialog box contains the following text:

Browsing network...

Waiting for response from first device...

Offlink browse not active.

Cancel

The 'Hardware' section shows the 'PowerFlex 70' drive selected, with its IP address 192.168.1.100. The 'Messages' section shows the same log of events as in the previous screenshot.

16. Configuring an ATV71/61 drive to replace a Powerflex® drive

Once the network has been scanned, you should obtain this:

The screenshot shows the RSLogix 5000 software interface. The top window displays 'Worst Case Device Usages' with a table:

Edits Enabled	Minimum CPU:	Maximum CPU:	Address	Pending	Connection:	Pending	Devices not included:	Pending
	192.168.1.100	192.168.1.100	192.168.1.1	0.04%	192.168.1.1	33.33%	0	0

The 'Hardware' window shows a tree view of the network scan results, including 'AC Drive', 'Communication Adapter', 'DSI to EtherNet/IP', 'Human Machine Interface', 'Modular DPI Devices', 'Programmable Logic Controller', 'Rockwell Automation miscellaneous', and 'SCA/Port Drives on EtherNet/IP'. The 'Vendor' list includes 'Rockwell Automation - Allen-Bradley', 'Rockwell Automation - Reliance Electric', 'Rockwell Software, Inc.', and 'Schneider Automation, Inc.'.

The 'Messages' window shows a list of messages:

Message Code	Date	Description
ENET:81E7	12/09/2007 11:29:32	Edits enabled.
ENET:81E4	12/09/2007 11:29:17	Mode changed to online. The communication timeout is 3000 msec. The online path is WXFR63469D1A8_ETHIP-1.
ENET:81E5	12/09/2007 11:29:15	Mode changed to offline.
ENET:81E8	12/09/2007 11:29:15	Edits cancelled.
ENET:81E7	12/09/2007 11:13:15	Edits enabled.

This last screen is the ATV71 drive controller data screen.

The screenshot shows the RSLogix 5000 software interface displaying the ATV71 drive controller data screen. The 'Scope' is set to 'TEST_ETHIP(contr)'. The 'Tag Name' column lists various data points, including 'ATV71-I.Data[7]' through 'ATV71-I.Data[11]', 'ATV71-O.Data[0]' through 'ATV71-O.Data[9]', and 'SVCI'. The 'Value' column shows the current values for these tags, and the 'Description' column provides details for each tag.

Tag Name	Value	Description
+ ATV71-I.Data[7]	0	IO scanning word 4
+ ATV71-I.Data[8]	0	IO scanning word 5
+ ATV71-I.Data[9]	0	IO scanning word 6
+ ATV71-I.Data[10]	0	IO scanning word 7
+ ATV71-I.Data[11]	0	IO scanning word 8
- ATV71-O	{...}	
- ATV71-O.Data	{...}	
+ ATV71-O.Data[0]	821.0	Allen Bradley drive logic command
+ ATV71-O.Data[1]	2000	Speed reference
+ ATV71-O.Data[2]	1.7	Io Scanning Word 1
+ ATV71-O.Data[3]	1.5	Io Scanning Word 2
+ ATV71-O.Data[4]	0	Io Scanning Word 3
+ ATV71-O.Data[5]	0	Io Scanning Word 4
+ ATV71-O.Data[6]	0	Io Scanning Word 5
+ ATV71-O.Data[7]	0	Io Scanning Word 6
+ ATV71-O.Data[8]	0	Io Scanning Word 7
+ ATV71-O.Data[9]	0	Io Scanning Word 8
+ SVCI	1	
U cycle	0	

The 'Status' window shows the controller is 'Running' and 'Complete - 0 error(s), 0 warning(s)'. The 'Errors' window is empty.

