



TeSys

TeSys Control - Giga Contactors
TeSys Protect - Giga Electronic Overload Relays
Catalogue 2022



se.com/tesys

Life Is On

Schneider
Electric



Start smart. Run smart. With TeSys™ motor controls.

Stay smart with the world's best-selling motor control solutions from the inventor of the world's first contactor – Schneider Electric™.

For almost a century, TeSys™ motor controls have driven the industry with innovations in motor protection, monitoring, and control.

It started with the introduction of the industry's first BAR contactor in 1924, and today, the legacy of innovation is built into every TeSys motor control device.

Best-in-class safety and reliability, plug-and-play architecture, and flexible functionality mean TeSys motor control solutions can meet your requirements across a wide range of applications, from the most common to the most advanced.

Wherever you are and anywhere your projects come together, you can trust Schneider Electric and TeSys contactors, circuit breakers, relays, and switches for unmatched reliability, complete compatibility with international standards, and the robust support of the Schneider Electric global supply network.

Start smart, run smart and stay smart with TeSys motor controls.

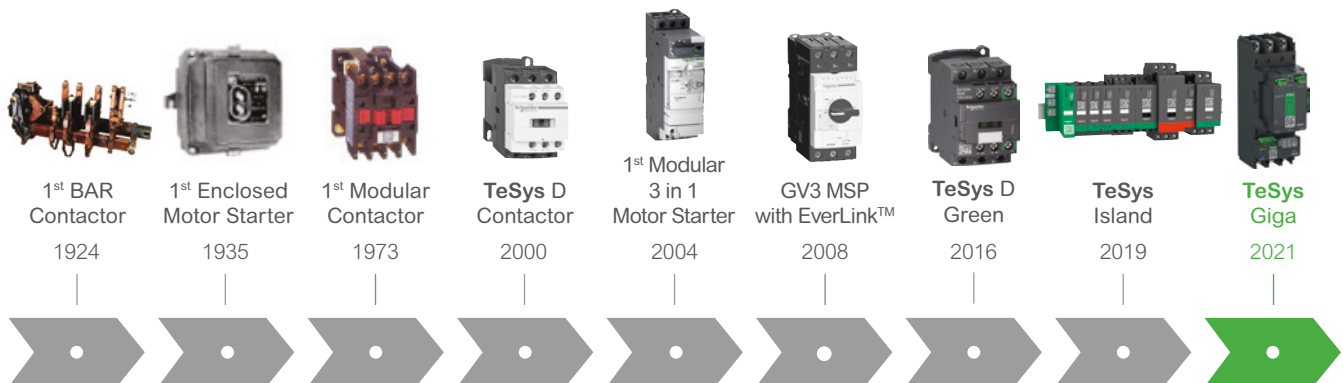

> Designed for evolution

TeSys Control

Giga Contactors

- Used for **TeSys** Control function
- New generation of high power contactors 115-800 A (AC-3)
- Less product references for easier selection and reduced inventory
- Designed to meet needs of demanding applications
- Width and depth alignment with overload relays and breakers for easier connection
- Compact design for less installation space consumption
- Coil designed for less energy consumption and wider voltage band-width
- Advanced contact wear diagnostic for predictive maintenance
- Modularity design for easy maintenance and short down times



TeSys Protect

Giga Electronic Overload Relays

- Used for **TeSys** Protect function
- New generation of electronic overload relays 28-630 A
- Less product references for easier selection and less inventory
- Compatible with **TeSys** Giga Contactors
- Wide setting range with advanced protections
- Full set of features for more flexibility
- Continuous monitoring with health and alarm indicators



On-line tools to configure your motor starters

EcoStruxure™ Motor Control Configurator



Scan or click
on the QR code

Build your starter configuration

- Build your motor starter configuration with different solutions
- Complete offer base suited for different countries.

Enhanced customer's journey

- Easy selection, replacing complex paper catalogs
- Covert into Bill of Materials (BoM) by adding the products to the cart.

Answers to customer needs

- Option to save and re-work your configurations
- Direct access to products documentation in one place
- Possibility with unique configurations ID and share.

Product Selector for TeSys Giga



Scan or click
on the QR code

Offer selection

- Easy selection of **TeSys** Giga Contactor or Overload Relays
- Intuitive tool to configure the devices to suit your needs
- Helps to select the right devices for your application.

Configure your motor starter components

- Options to select auxiliaries and accessories
- Configure reversers and changeover contactors with ease
- Get the extensive bill of material, export it in standard format (PDF, XLS), or drop it into the product cart
- Access to technical information and documentations for every item.

EcoStruxure Motor Management Design

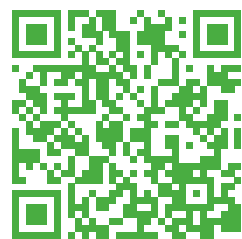

Scan or click
on the QR code

Electrical design calculations for high-power motors

Easily perform basic calculations related to transformer size, short-circuit current and voltage drop, comparing direct-on-line, star-delta, soft-starter, and variable speed drive. Verify starting feasibility from mechanical standpoint and ensure power quality objectives are met, for power factor or harmonic levels. Check energy saving potential of using a variable speed drive for centrifugal pumps and fans.

Offer selection and report

Select among latest compatible offers to build a complete motor management solution: circuit breakers, contactors, MCC panels, drives, protection relays, power factor capacitors, active filters, power quality monitoring and services.

Get a summary report with calculations and recommended offers.

TeSys Control

TeSys Protect

General contents

TeSys Control – Giga Contactors	5
Introduction.....	6
Description	9
Product references	12
Technical data for designers.....	25
TeSys Protect – Giga Electronic Overload Relays.....	37
Introduction.....	38
Description	39
Product references	40
Technical data for designers.....	43
TeSys Giga series - Device selection	49
Coordination tables	
TeSys Giga Contactors for various applications	

Product references – coding principle

> TeSys Giga Contactors

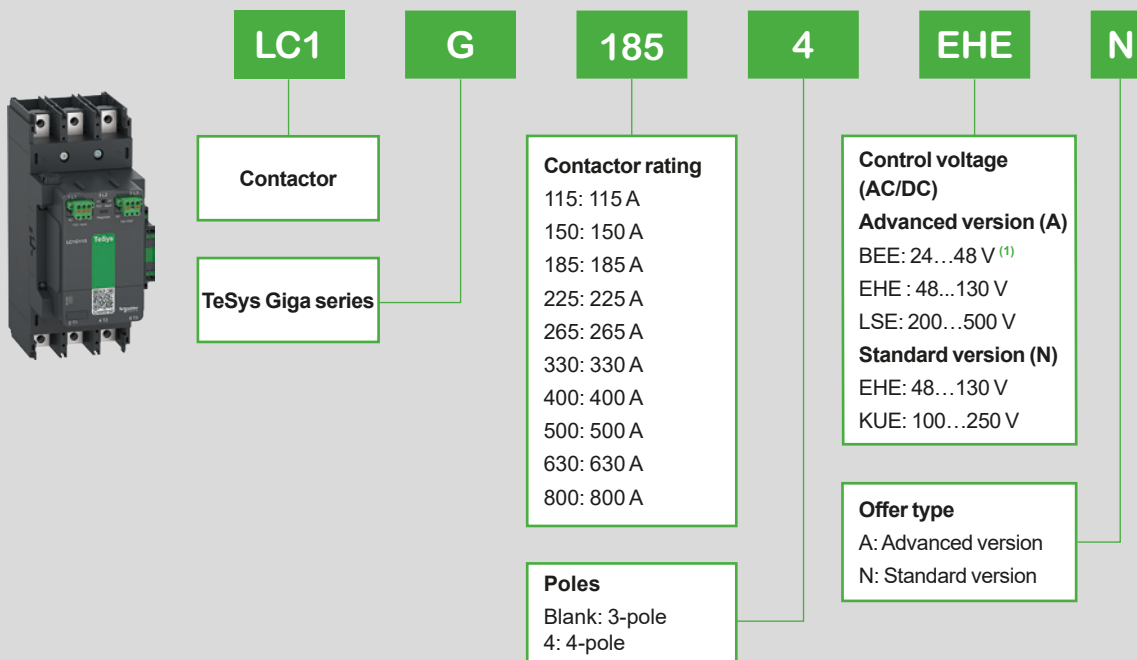

Example:



LC1G400LSEA TeSys Giga Contactor Advanced version 400 A, 3-pole, 200...500 V AC/DC coil, with PLC control.
 LC1G1854EHEN TeSys Giga Contactor Standard version 185 A, 4-pole, 48...130 V AC/DC coil, without PLC control.

⁽¹⁾ 24...48 V AC/DC control voltage option is available for LC1G115...LC1G500 ratings.

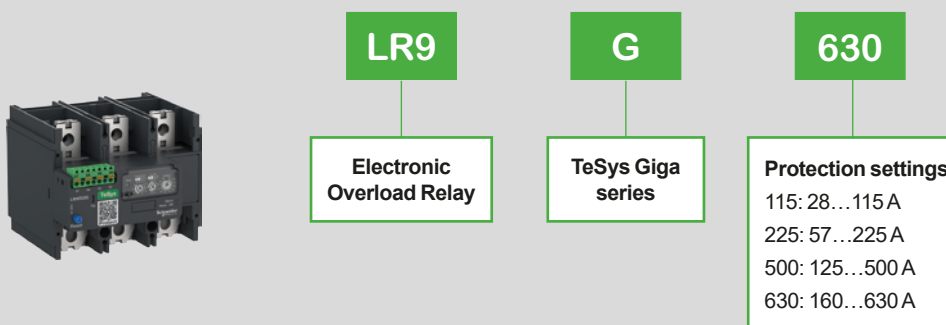
> TeSys Giga Electronic Overload Relays



TeSys Control Giga Contactors

TeSys Giga Contactors		
Type of product	Range	Pages
Introduction		6
TeSys Giga Contactors Advanced version - 3 and 4-poles	3-pole from 115 to 800 A – AC-3 3-pole and 4-pole from 250 to 1050 A – AC-1	 12
TeSys Giga Contactors Standard version - 3 and 4-poles	3-pole from 115 to 800 A – AC-3 3-pole and 4-pole from 250 to 1050 A – AC-1	 14
Auxiliary modules, Accessories, Retrofit kits for TeSys Giga Contactors		16
Spare parts for TeSys Giga Contactors		22
Technical Data for Designers		25

> Quality and Performance as high priority

TeSys Giga A new Generation series with digital innovation

Over more than 4 decades, the TeSys F range of contactors has built a high reputation for performance, reliability, and quality. The TeSys F range set the industrial standard for high power contactors with an installed base of millions of products. TeSys F contactors were the first choice of many OEMs, control panel builders and industrial users.

But industry requirements have evolved to demand process performance monitoring through data networks and online expert services.

TeSys Giga is Schneider Electric's new range of contactors that answer these evolving needs. TeSys Giga Contactors support the evolution of processes and offer new services to reduce non-production time to a minimum. Replacing TeSys F Contactors, TeSys Giga Contactors address a wide range of demanding applications with built-in advanced features and functionalities.



Futuristic ready...

TeSys Giga Contactors are designed to work with components and accessories with advanced performance. The characteristics of robustness and longevity are maintained, both in the connectors and in the switching.

Continuous local and remote monitoring of contact wear optimizes predictive maintenance by allowing you to replace contacts only when necessary, facilitated by diagnostic visual indicator.

Every customer will benefit from the innovative design and feature, including the compact size, wideband electronic coils, embedded auxiliary contact blocks, ergonomic design, or flexibility in connections.

> Applications



AC-3/AC-3e utilization category



AC-1 utilization category

- TeSys Giga Contactors provide robust control solutions for AC-3/AC-3e applications up to 800 A and AC-1 applications up to 1050 A.
- TeSys Giga Contactors can be part of a direct-on-line motor starter, reversing motor starter or a star-delta motor starter and power switching application.
- TeSys Giga Contactors provide contact wear diagnostic and wideband AC/DC control.
- Suitable for type 2 coordination as per IEC60947-4-1.

> Right choice for a wide range of demanding applications



TeSys Giga Contactors' unique design meets the common requirements of demanding high power applications:

- Conform to multi standards to suit global needs
- Long life expectancy in harsh environments
- Suitable for high efficiency motors
- Very good resistance to vibrations
- High uptime thanks to predictive maintenance
- Optimized installation and maintainability.

> Intelligent design for greater advantages



- Interlock location, with knock-out cover
- On/Off switch for PLC input
- Push-in type control terminals enabling quick wiring and assembly
- Diagnosis LED for contact wear & voltage abnormality
- Built-in 1 NO + 1 NC auxiliary contact block
- Unique QR code providing quick access to complete product data
- Mechanical indicator for contactor open and closed status



Higher flexibility

TeSys Giga Contactors can be mounted in different orientation without derating, providing high flexibility of your panel design.

Control wiring, auxiliary contacts and control module are accessible from the front.



Contact wear diagnostic and predictive maintenance

Contact wear is monitored by a dedicated module and shown in the front panel through LED, therefore the, predictive maintenance can be planned for replacing the complete set of switching modules, thus avoiding break-down maintenance. Switching modules ⁽¹⁾ can be replaced quickly and easily thanks to their Plug and Play design.

⁽¹⁾ Refer to page 23 for details on switching modules.

> Key features

Advanced contactor control

- The electronic control module provides wideband AC/DC coil control voltage, from 24 V to 500 V, allowing quick adaptation of existing industrial processes as well as new projects.
- The low power consumption of the coils could lead to significant savings on automation equipment. It's now possible to use interface relays with a lower rating, resulting in lower heat emission in the panel.
- The low power consumption of the coils also takes up less space in the panel and simplifies the diagrams by connecting these coils directly to the output cards of the PLCs.

Simplified wiring

- The pole pitch of the power terminals allows direct mounting and connection to TeSys Giga Electronic Overload Relays. Standardization of panel mounting and assembly reduces costs and assembly time.
- Push-in connection for control terminals provides flexibility, ease of connections, and reduced assembly and installation time.

Enhanced durability

- Durability is a top priority. TeSys Giga Contactors are designed to offer uncompromising robustness and maintenance accessibility to site technicians. The duration of production down-time is reduced, resulting in improved profitability on your investment.

Advanced diagnostic features

- On-board diagnostics is a new feature in our latest generation of high power contactors. Counting the number of operations as well as monitoring duration of use and pole condition provides numerous benefits for the customer and improves reliability and maintenance planning.

Compact size

- Compact size provides easy access to power connections for connecting cables and busbars.

Easy maintenance

- The poles are designed as replaceable switching modules, so the performance of a used contactor can be fully restored. The modular design allows a quick and long-lasting replacement.
- Coils are accessible from the front and maintained with very low down times.

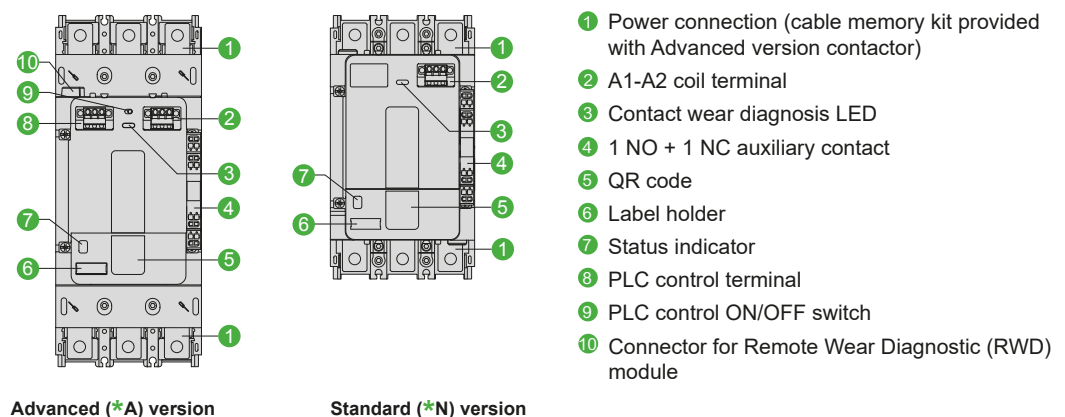

*: contactor references finishing by A or by N.

TeSys Control Giga Contactors

Introduction

A comprehensive range of TeSys Giga Contactors that are available in 'Advanced' and 'Standard' versions, in 3 sizes, covering several ratings.

A common range of auxiliary contacts and accessories, enabling high flexibility and simplicity.

> TeSys Giga Contactors – Advanced version



115...225 A



265...500 A



630...800 A

Power & control

- 3 or 4 power poles
- 115 to 800 A (AC-3)
- 250 to 1050 A (AC-1)
- Embedded 1 NO + 1 NC auxiliary contacts
- Push-in type terminals for coils & control

Remote control

- 24-48 V, 48-130 V, 200-500 V AC/DC coils
- Low consumption coils
- Wide voltage range coils (direct coil control)
- Digital control input (PLC output digital coil control)
- Embedded surge suppressor

Diagnostic

- Embedded wear diagnostic
- Embedded control voltages diagnostic
- Self diagnosis function
- Local alarm signaling (LED)
- Remote wear diagnostic signaling kit (accessory)

Mounting

- 'Cable memory' adapter enables maintenance without removing power cables and busbar connections.

Standards and Certifications

- Multiple standards
- International certifications

> TeSys Giga Contactors – Standard version



115...225 A



265...500 A



630...800 A

Power & control

- 3 or 4 power poles
- 115 to 800 A (AC-3)
- 250 to 1050 A (AC-1)
- Embedded 1 NO + 1 NC auxiliary contacts
- Push-in type terminals for coils & control

Remote control

- 48-130 V, 100-250 V AC/DC coils
- Wide voltage range coils (direct coil control)
- Embedded surge-suppressor

Diagnostic

- Embedded wear diagnostic
- Embedded control voltages diagnostic
- Self diagnosis function
- Local alarm signaling (LED)

Certifications

- Multiple standards
- International certifications

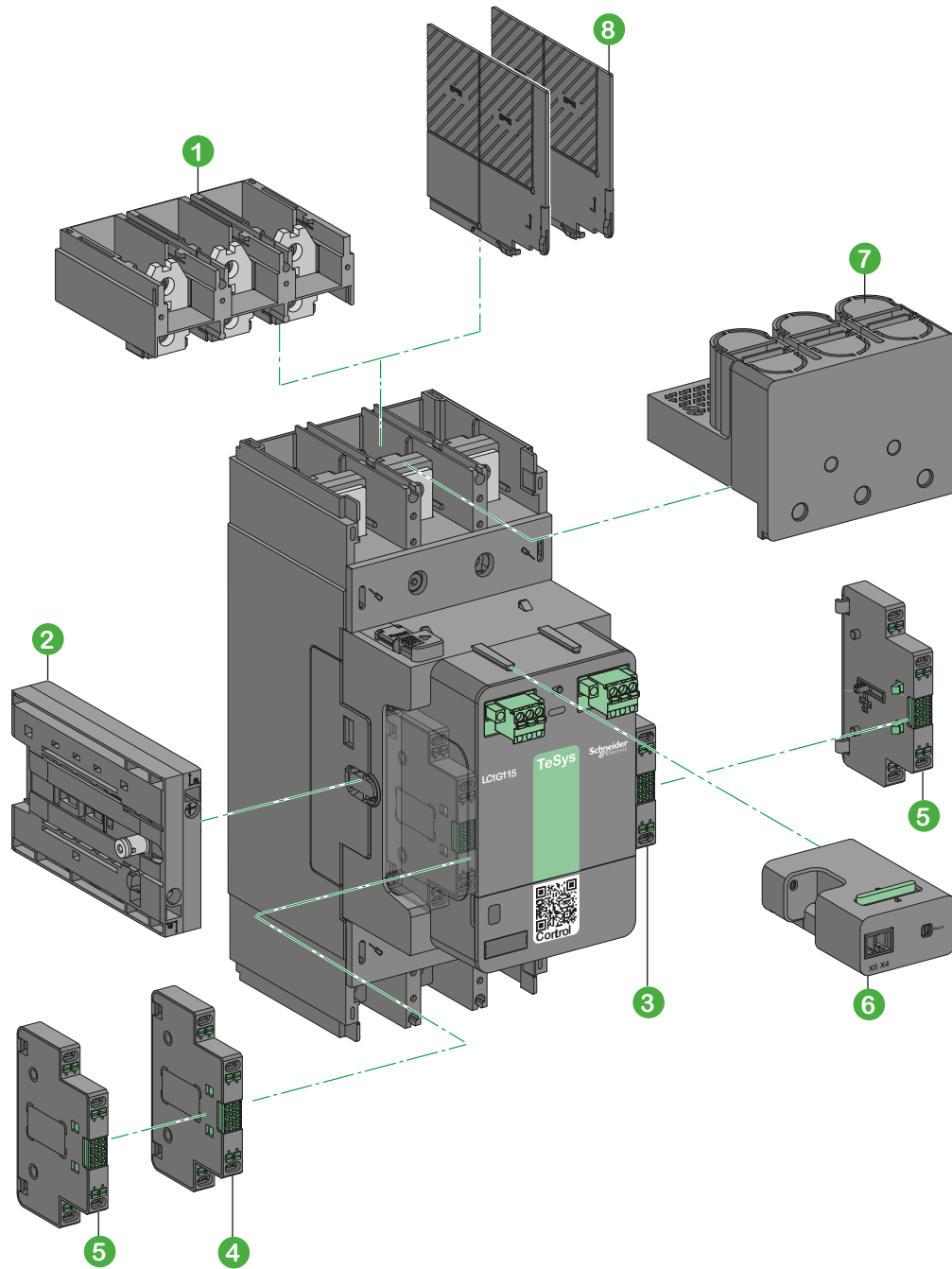

- ① Cable memory kit **LA9G3102**, is always supplied along with Advanced version, and it's an optional accessory for Standard version.
- ② Mechanical interlock **LA9G970**, can be installed on either side of the contactor.
- ③ Auxiliary contact module **LAG8N113P** (1 NO + 1 NC) supplied with LC1G contactor.
- ④ Auxiliary contact modules **LAG8N113P / LAG8N203P**, can be installed on the contactor lateral faces ⁽¹⁾
- ⑤ Auxiliary contact modules **LAG8N113 / LAG8N203**, can be installed on either side as 2nd set of contacts.
- ⑥ Remote Wear Diagnostic (RWD) Module **LA9GRD01 / LA9GRD10**, can be installed and used only in Advanced version.
- ⑦ IP 20 terminal shroud **LA9G3701**.
- ⑧ Phase separators **LA9G3801**, please refer to pages 16 to 20 for complete details of available accessories.

Note: a maximum of 2 auxiliary contact modules can be mounted on each side of the contactor.
 (1) Does not increase the contactor dimensions when fitted on both sides.

TeSys Control

Giga Contactors – Advanced – 3-pole and 4-pole

Product references

TeSys Giga 3-pole Advanced contactors – For motor control (115 to 800 A)



Motor ratings (kW) $\theta \leq 60^\circ\text{C}$

AC-3							AC-3e ⁽¹⁾							AC-4						
230 V	400 V	415 V	440 V	500 V	690 V	1000 V	230 V	400 V	415 V	440 V	500 V	690 V	1000 V	230 V	400 V	415 V	440 V	500 V	690 V	1000 V
kW	kW	kW	kW	kW	kW	kW	kW	kW	kW	kW	kW	kW	kW	kW	kW	kW	kW	kW	kW	kW
30	55	55	75	75	75	-	30	55	55	75	75	75	-	30	55	55	65	65	75	-
37	75	75	90	90	90	75	37	75	75	90	90	90	75	37	75	75	80	90	90	75
55	90	90	110	110	110	75	55	90	90	110	110	110	75	55	90	90	100	110	110	75
55	110	110	132	132	160	132	55	110	110	132	132	160	132	55	110	110	129	132	132	110
75	132	132	160	160	200	160	75	132	132	160	160	200	160	75	132	132	150	160	160	160
90	160	160	200	200	220	185	90	160	160	185	200	220	185	90	160	160	185	200	220	185
110	200	200	250	250	315	220	110	200	200	250	250	315	220	110	200	200	220	250	315	220
160	250	250	315	355	355	335	147	250	250	280	315	355	335	150	250	250	295	295	355	280
200	335	375	400	400	500	450	180	315	335	355	375	500	450	180	315	335	355	375	450	355
250	450	450	450	500	560	450	200	335	355	375	425	560	450	200	375	355	375	400	475	400

TeSys Giga 3-pole and 4-pole Advanced contactors for load control only (non motor) – (250 to 1050 A)

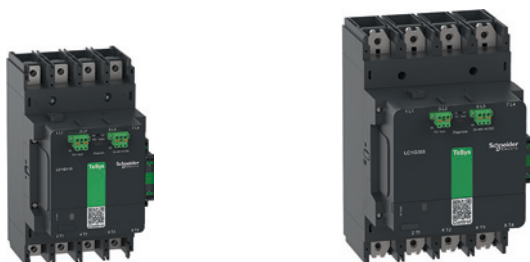

Maximum current (A) ($\theta \leq 40^\circ\text{C}$)	General purpose continuous current (A)	Reference					
		Advanced version contactors					
		AC/DC coil voltage					
IEC	UL	3-pole			4-pole		
AC-1		24...48 V	48...130 V	200...500 V	24...48 V	48...130 V	200...500 V
250	210	LC1G115BEEA	LC1G115EHEA	LC1G115LSEA	LC1G1154BEEA	LC1G1154EHEA	LC1G1154LSEA
275	230	LC1G150BEEA	LC1G150EHEA	LC1G150LSEA	LC1G1504BEEA	LC1G1504EHEA	LC1G1504LSEA
305	250	LC1G185BEEA	LC1G185EHEA	LC1G185LSEA	LC1G1854BEEA	LC1G1854EHEA	LC1G1854LSEA
330	290	LC1G225BEEA	LC1G225EHEA	LC1G225LSEA	LC1G2254BEEA	LC1G2254EHEA	LC1G2254LSEA
385	340	LC1G265BEEA	LC1G265EHEA	LC1G265LSEA	LC1G2654BEEA	LC1G2654EHEA	LC1G2654LSEA
440	390	LC1G330BEEA	LC1G330EHEA	LC1G330LSEA	LC1G3304BEEA	LC1G3304EHEA	LC1G3304LSEA
550	490	LC1G400BEEA	LC1G400EHEA	LC1G400LSEA	LC1G4004BEEA	LC1G4004EHEA	LC1G4004LSEA
700	630	LC1G500BEEA	LC1G500EHEA	LC1G500LSEA	LC1G5004BEEA	LC1G5004EHEA	LC1G5004LSEA
1050	850	-	LC1G630EHEA	LC1G630LSEA	-	LC1G6304EHEA	LC1G6304LSEA
1050	900	-	LC1G800EHEA	LC1G800LSEA	-	LC1G8004EHEA	LC1G8004LSEA

(1) Switching of IE3/IE4 high efficiency squirrel-cage motors.

TeSys Control

Giga Contactors – Advanced – 3-pole and 4-pole

Product references

Motor ratings (HP) UL- 3phase				Reference Advanced version contactors AC/DC coil voltage 3-pole		
200/208 V	230/240 V	460/480 V	575/600 V	24-48 V	48-130 V	200-500 V
30	40	75	100	LC1G115BEEA	LC1G115EHEA	LC1G115LSEA
40	50	100	125	LC1G150BEEA	LC1G150EHEA	LC1G150LSEA
50	60	125	150	LC1G185BEEA	LC1G185EHEA	LC1G185LSEA
60	75	150	150	LC1G225BEEA	LC1G225EHEA	LC1G225LSEA
75	100	200	200	LC1G265BEEA	LC1G265EHEA	LC1G265LSEA
100	125	250	300	LC1G330BEEA	LC1G330EHEA	LC1G330LSEA
125	150	300	400	LC1G400BEEA	LC1G400EHEA	LC1G400LSEA
150	200	400	450	LC1G500BEEA	LC1G500EHEA	LC1G500LSEA
250	300	600	700	-	LC1G630EHEA	LC1G630LSEA
300	350	700	800	-	LC1G800EHEA	LC1G800LSEA

TeSys Control

Giga Contactors – Standard – 3-pole and 4-pole

Product references

TeSys Giga 3-pole Standard contactors – For motor control – (115 to 800 A)



Motor ratings (kW) $\theta \leq 60^\circ\text{C}$

IEC AC-3							AC-3e ⁽¹⁾							AC-4							
230 V	400 V	415 V	440 V	500 V	690 V	1000 V	230 V	400 V	415 V	440 V	500 V	690 V	1000 V	230 V	400 V	415 V	440 V	500 V	690 V	1000 V	
kW	kW	kW	kW	kW	kW	kW	kW	kW	kW	kW	kW	kW	kW	kW	kW	kW	kW	kW	kW	kW	kW
30	55	55	75	75	75	-	30	55	55	75	75	75	-	30	55	55	65	65	75	-	
37	75	75	90	90	90	75	37	75	75	90	90	90	75	37	75	75	80	90	90	75	
55	90	90	110	110	110	75	55	90	90	110	110	110	75	55	90	90	100	110	110	75	
55	110	110	132	132	160	132	55	110	110	132	132	160	132	55	110	110	129	132	132	110	
75	132	132	160	160	200	160	75	132	132	160	160	200	160	75	132	132	150	160	160	160	
90	160	160	200	200	220	185	90	160	160	185	200	220	185	90	160	160	185	200	220	185	
110	200	200	250	250	315	220	110	200	200	250	250	315	220	110	200	200	220	250	315	220	
160	250	250	315	355	355	335	147	250	250	280	315	355	335	150	250	250	295	295	355	280	
200	335	375	400	400	500	450	180	315	335	355	375	500	450	180	315	335	355	375	450	355	
250	450	450	450	500	560	450	200	335	355	375	425	560	450	200	375	355	375	400	475	400	

TeSys Giga 3-pole and 4-pole Standard contactors for load control only (non motor) – (250 to 1050 A)



Maximum current (A) ($\theta \leq 40^\circ\text{C}$)	General purpose continuous current (A)	Reference Standard version contactors			
		AC/DC coil voltage		4-pole	
		3-pole		4-pole	
IEC AC-1	UL	48...130 V	100...250 V	48...130 V	100...250 V
250	210	LC1G115EHEN	LC1G115KUEN	LC1G1154EHEN	LC1G1154KUEN
275	230	LC1G150EHEN	LC1G150KUEN	LC1G1504EHEN	LC1G1504KUEN
305	250	LC1G185EHEN	LC1G185KUEN	LC1G1854EHEN	LC1G1854KUEN
330	290	LC1G225EHEN	LC1G225KUEN	LC1G2254EHEN	LC1G2254KUEN
385	340	LC1G265EHEN	LC1G265KUEN	LC1G2654EHEN	LC1G2654KUEN
440	390	LC1G330EHEN	LC1G330KUEN	LC1G3304EHEN	LC1G3304KUEN
550	490	LC1G400EHEN	LC1G400KUEN	LC1G4004EHEN	LC1G4004KUEN
700	630	LC1G500EHEN	LC1G500KUEN	LC1G5004EHEN	LC1G5004KUEN
1050	850	LC1G630EHEN	LC1G630KUEN	LC1G6304EHEN	LC1G6304KUEN
1050	900	LC1G800EHEN	LC1G800KUEN	LC1G8004EHEN	LC1G8004KUEN

(1) Switching of IE3/IE4 high efficiency squirrel-cage motors.

TeSys Control

Giga Contactors – Standard – 3-pole and 4-pole

Product references

Motor ratings (HP) UL- 3phase				Reference Standard version contactors AC/DC coil voltage 3-pole	
200/208 V	230/240 V	460/480 V	575/600 V	48-130 V	100-250 V
30	40	75	100	LC1G115EHEN	LC1G115KUEN
40	50	100	125	LC1G150EHEN	LC1G150KUEN
50	60	125	150	LC1G185EHEN	LC1G185KUEN
60	75	150	150	LC1G225EHEN	LC1G225KUEN
75	100	200	200	LC1G265EHEN	LC1G265KUEN
100	125	250	300	LC1G330EHEN	LC1G330KUEN
125	150	300	400	LC1G400EHEN	LC1G400KUEN
150	200	400	450	LC1G500EHEN	LC1G500KUEN
250	300	600	700	LC1G630EHEN	LC1G630KUEN
300	350	700	800	LC1G800EHEN	LC1G800KUEN

TeSys Control

Giga Contactors – Auxiliary contact modules

Product references

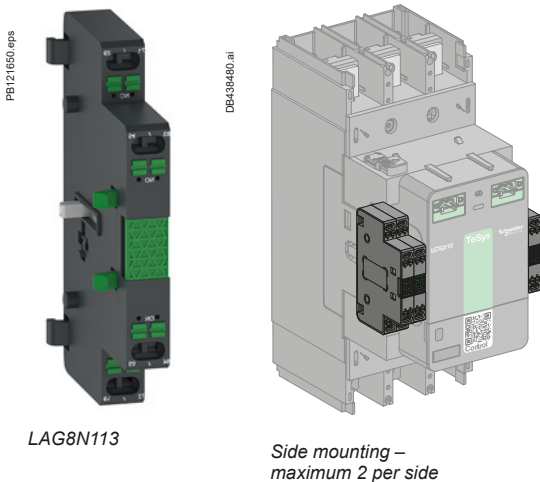

LAG8N113

Side mounting – maximum 2 per side

Auxiliary contact modules

Auxiliary contacts give an indication of the contactor status. They can be used for remote visual signaling, alarming, electrical locking, relay activation, etc...

Each contactor is equipped with 1 NO + 1 NC auxiliary contact block as standard.

■ Mechanically linked mirror contacts

The NC contact of the auxiliary contact block is mirror contact in conformity to IEC 60947-5-1 and it is mechanically linked to reliably represent the state of the main power contacts and wherever auxiliary contact state reliability is essential. The NC of the auxiliary contact can't be closed at the same time as a normally open power contact.

Types of connections:

■ Push-in type.

Wide contactor compatibility

TeSys Giga auxiliary contact module is compatible with the whole range of TeSys Giga Contactors.

Each TeSys Giga Contactor can be equipped with up to 4 auxiliary contact modules.

Electrical characteristics

Characteristics	
Rated thermal current (A)	10
Minimum load	1 mA at 17 V DC
Contact reliability	Failure rate <10 ⁻⁸

Operational power of contacts conforming to IEC 60947-5-1 - Electrical durability

category AC-15

Operating cycles	V	24	48	115	230	400	500
1 million	VA	60	120	280	560	800	500
2 million	VA	24	48	115	230	400	250
3 million	VA	16	32	80	160	280	150

category DC-13

Operating cycles	V	Same current strategy		Same power strategy		
		24	48	125	250	440
0.5 million	W	100	100	105	110	88
1 million	W	48	72	54	54	55
2 million	W	24	36	38	38	39
3 million	W	16	24	25	25	33

Connector characteristics

Push-in connection - Dual input			Min/max c.s.a.
Flexible cable per input	1 conductor with cable end	mm ²	0.75...2.5
	2 conductors with Dual Sleeve	mm ²	0.75...2.5
Stripping length		mm	10
Solid cable per input	1 conductor	mm ²	0.75...2.5
	Stripping length	mm	12

Auxiliary contact modules

Description	Terminal type	Position	Type of contacts	Sold in lots of	Reference
Auxiliary contact module	Push-in	1 st left or right	1 NO + 1 NC	1	LAG8N113P ⁽¹⁾
			2 NO	1	LAG8N203P
		2 nd left or right	1 NO + 1 NC	1	LAG8N113
			2 NO	1	LAG8N203

⁽¹⁾ Always supplied with TeSys Giga LC1G contactors, fitted to the right side lateral face.

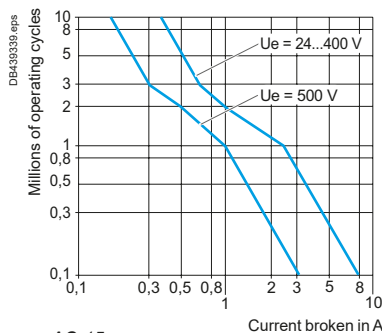

AC-15

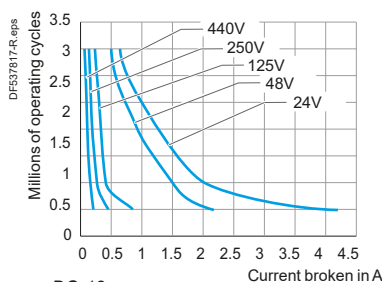

DC-13

Power terminals

‘Cable Memory’ connection blocks

Cables or busbars can be connected to the contactor by means of the optional cable memory connection blocks. When the contactor is removed for maintenance, the cables or busbars remain connected to these connection blocks, making reinstallation faster and easier.



LA9G3101

Cable memory ⁽¹⁾				
Description	Compatible with contactors	Quantity Set of	Reference	
‘Cable memory’ for 3-pole contactors – for holding cables in place	LC1G115...LC1G225	2	LA9G3101	
	LC1G265...LC1G500	2	LA9G3102	
	LC1G630...LC1G800	2	LA9G3103	
‘Cable memory’ for 4-pole contactors – for holding cables in place	LC1G115...LC1G225	2	LA9G4101	
	LC1G265...LC1G500	2	LA9G4102	
	LC1G630...LC1G800	2	LA9G4103	

(1) ‘Cable memory’ connection blocks are always supplied with Advanced contactor version.

Flexible terminal extensions

Flexible connecting bars to connect TeSys Giga contactors with MCCBs mounted in the same plane and orientation. These bars can be used along with Advanced or Standard version contactors. They help to get a quick and easy connection between contactor and MCCB with saving in installation time.

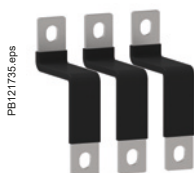

LA9G3111

‘Flexible terminal extensions’ for MCCBs				
Description	Compatible with contactors	To connect with NSX/NS MCCBs	Quantity Set of	Reference
Flexible terminal extensions 3-pole	LC1G115...LC1G225	NSX100...NSX250	3	LA9G3111
	LC1G265...LC1G500	NSX400...NSX630	3	LA9G3112
	LC1G630...LC1G800	NS800...NS1250	3	LA9G3113
Flexible terminal extensions 4-pole	LC1G115...LC1G225	NSX100...NSX250	4	LA9G4111
	LC1G265...LC1G500	NSX400...NSX630	4	LA9G4112
	LC1G630...LC1G800	NS800...NS1250	4	LA9G4113

Straight terminal extensions



LA9G3601

Description	Suitable for	Compatible with contactors	Quantity Set of	Reference
Straight terminal extension	3P	LC1G115...LC1G225	3	LA9G3601
		LC1G265...LC1G500	3	LA9G3602
		LC1G630...LC1G800	3	LA9G3603
	4P	LC1G115...LC1G225	4	LA9G4601
		LC1G265...LC1G500	4	LA9G4602
		LC1G630...LC1G800	4	LA9G4603

Right angled terminal extensions



LA9G3682

Description	Suitable for	Compatible with contactors	Quantity Set of	Reference
Right angled side terminal extension	3P	LC1G115...LC1G225	3	LA9G3661
		LC1G265...LC1G500	3	LA9G3662
		LC1G630...LC1G800	3	LA9G3663
Right angled large terminal extension	3P	LC1G115...LC1G225	3	LA9G3671
		LC1G265...LC1G500	3	LA9G3672
		LC1G630...LC1G800	3	LA9G3673
Right angled rear terminal extension	3P	LC1G115...LC1G225	3	LA9G3681
		LC1G265...LC1G500	3	LA9G3682
		LC1G630...LC1G800	3	LA9G3683

Edgewise terminal extensions



LA9G3631

Description	Suitable for	Compatible with contactors	Quantity Set of	Reference
Edgewise terminal extension	3P	LC1G115...LC1G225	3	LA9G3631
		LC1G265...LC1G500	3	LA9G3632
		LC1G630...LC1G800	3	LA9G3633
	4P	LC1G115...LC1G225	4	LA9G4631
		LC1G265...LC1G500	4	LA9G4632
		LC1G630...LC1G800	4	LA9G4633



LA9G3611

Power terminals

Spreader kits

Description	Suitable for	Compatible with contactors	Increase of Pole pitch	Quantity Set of	Reference
Spreader kits	3P	LC1G115...LC1G225	35 to 45 mm	3	LA9G3611
		LC1G265...LC1G500	45 to 70 mm	3	LA9G3612
	4P	LC1G115...LC1G225	35 to 45 mm	4	LA9G4611
		LC1G265...LC1G500	45 to 70 mm	4	LA9G4612



LA9G3613

Terminal extensions for larger power connections

Description	Suitable for	Compatible with contactors	Power connection size	Quantity Set of	Reference
Terminal connections	3P	LC1G400...LC1G500	50 mm width	3	LA9G3613
		LC1G630...LC1G800	80 mm width	3	LA9G3614
	4P	LC1G400...LC1G500	50 mm width	4	LA9G4613
		LC1G630...LC1G800	80 mm width	4	LA9G4614



LA9G4711

Spreader kits suitable for box type connectors

Description	Suitable for	Compatible with contactors	Increase of Pole pitch	Suitable for box connectors	Quantity Set of	Reference
Spreader kits for box connectors	3P	LC1G115...LC1G225	35 to 45 mm	DZ2 FJ1/FH1 & AL400	3	LA9G3711
		LC1G265...LC1G500	45 to 70 mm	DZ2 FJ1/FK1 & AL400/AL600	3	LA9G3712
		LC1G630...LC1G800	70 to 80 mm	DZ2 FL1/FK1 & Type S/AL600	3	LA9G3714
	4P	LC1G115...LC1G225	35 to 45 mm	DZ2 FJ1/FH1 & AL400	4	LA9G4711
		LC1G265...LC1G500	45 to 70 mm	DZ2 FJ1/FK1 & AL400/AL600	4	LA9G4712
		LC1G630...LC1G800	70 to 80 mm	DZ2 FL1/FK1 & Type S/AL600	4	LA9G4714

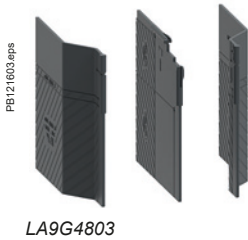

Power terminal accessories

Phase separators

Description	Suitable for	Compatible with contactors	Quantity Set of	Reference
Phase separators ⁽¹⁾	3P	LC1G115...LC1G800	2	LA9G3801
	4P	LC1G115...LC1G800	3	LA9G4801
	3P – with 50/80 mm spreaders	LC1G400...LC1G800	2	LA9G3803 ⁽²⁾
	4P – with 50/80 mm spreaders	LC1G400...LC1G800	2	LA9G4803 ⁽³⁾



Terminal shrouds

Description	Compatible with contactors	Quantity Set of	Reference	
			3P	4P
IP 20 Terminal shrouds ⁽¹⁾	LC1G115...LC1G225	2	LA9G3701	LA9G4701
	LC1G265...LC1G500	2	LA9G3702	LA9G4702
	LC1G630...LC1G800	2	LA9G3703	LA9G4703



IP20 Lug cover for connection kits ⁽⁴⁾

Lug covers are used along with IP 20 terminal shrouds and star-delta, reverser and changeover connection kit assemblies to improve insulation of the coupling bars and achieve IP 20 for the complete assembly.

IP20 Lug cover for connection kits

Description	Suitable for	Compatible with contactors	Quantity Set of	Reference
IP 20 Lug cover	3P	LC1G115...LC1G800 ⁽⁴⁾	6	LA9G3707
	4P	LC1G115...LC1G800 ⁽⁴⁾	8	LA9G4707



Lugs for cable set

Description	Compatible with contactors	Cable section	Reference	
			Set of 3 for 3P	Set of 4 for 4P
Lugs for cable	LC1G115...LC1G225	120 mm ²	LV429252	LV429256
	LC1G115...LC1G225	150 mm ²	LV429253	LV429257
	LC1G115...LC1G225	185 mm ²	LV429254	LV429258
	LC1G265...LC1G500	240 mm ²	LV432500	LV432501
	LC1G265...LC1G500	300 mm ²	LV432502	LV432503



Star-Delta (Wye-Delta) connection kits ⁽⁵⁾

Description	Suitable for	Compatible for Line (KM2) and Delta (KM3) contactor	+ Star contactor (KM1)	Reference
Connection kit: bars for Line-Delta-Star contactor assembly	3P	LC1G115...LC1G225	LC1G115...LC1G225	LA9GQQ330
		LC1G265...LC1G500	LC1G115...LC1G225	LA9GSQ330
		LC1G265...LC1G500	LC1G265...LC1G500	LA9GSS330
		LC1G630...LC1G800	LC1G265...LC1G500	LA9GTS330
	with cable memory kit	3P	LC1G630...LC1G800	LC1G630...LC1G800
LC1G265...LC1G500			LC1G115...LC1G225	LA9GSQ331
		LC1G630...LC1G800	LC1G265...LC1G500	LA9GTS331

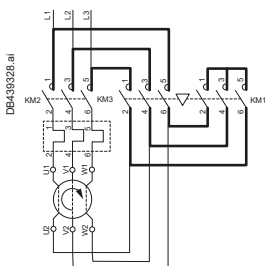

Mechanical interlock

Description	Suitable for	Compatible with contactors		Reference
		Contactor 1	Contactor 2	
Mechanical interlock between contactors ⁽⁶⁾	3P and 4P	LC1G115...225	LC1G115...225	LA9G970
		LC1G265...500	LC1G265...500	LA9G970
		LC1G265...500	LC1G115...225	LA9G971
	3P	LC1G630...800	LC1G265...500	LA9G972
		LC1G630...800	LC1G630...800	LA9G973

Note: RE17RMMWS timer to be used for Star-Delta starter application.

⁽¹⁾ Either phase separators or terminal shrouds can only be mounted. Phase separators or terminal shrouds are mandatory for operational voltage, $U_e \geq 690$ V.

⁽²⁾ To be used with LA9G3613 and LA9G3614.

⁽³⁾ To be used with LA9G4613 and LA9G4614.

⁽⁴⁾ 2 sets of IP20 lug covers are needed for assemblies with LC1G630 and LC1G800 contactors.

⁽⁵⁾ UL listed.

⁽⁶⁾ Maximum 3 auxiliary contacts can be installed between 2 contactors with mechanical interlock kit.

TeSys Control

Giga Contactors – Power wiring accessories

Product references

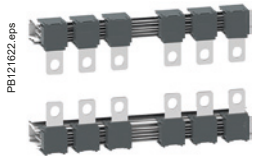

LA9G3760

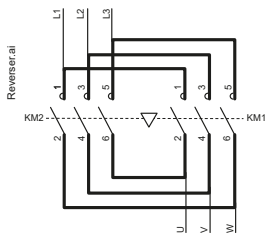

Reverser connection kits

Description	Suitable for	Compatible with contactors	Reference
Connection kit: bars for reverser contactor assembly	3P	LC1G115...LC1G225	LA9G3760
		LC1G265...LC1G500	LA9G3761
		LC1G630...LC1G800	LA9G3762



LA9G3750

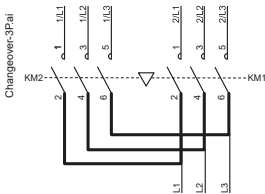

Changeover connection kits

Description	Suitable for	Compatible with contactors	Reference
Connection kit: bars for changeover contactor assembly	3P	LC1G115...LC1G225	LA9G3750
		LC1G265...LC1G500	LA9G3751
		LC1G630...LC1G800	LA9G3752
	4P	LC1G115...LC1G225	LA9G4750
		LC1G265...LC1G500	LA9G4751
		LC1G630...LC1G800	LA9G4752

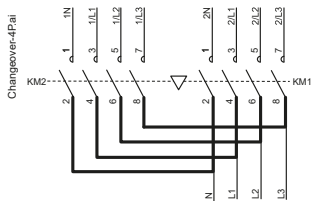

TeSys Control

Giga Contactors – Mounting accessories

Product references

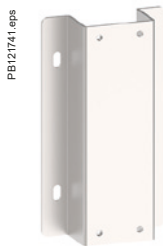

PB121741.eps

LA9GRFB1

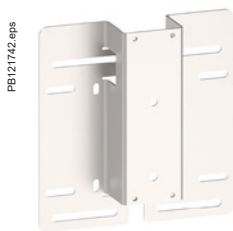

PB121742.eps

LA9GRFB2

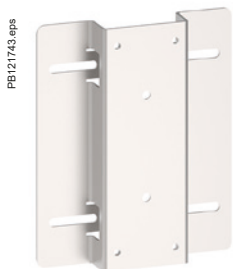

PB121743.eps

LA9GRFB3

Retrofit bases

- Suitable for 3 pole contactors
- Retrofit bases to replace similar ratings of TeSys F contactors with TeSys Giga Contactors
- Enables quick and simple replacement in the existing installation
- 3 references to cover ranges from LC1F115 to F800

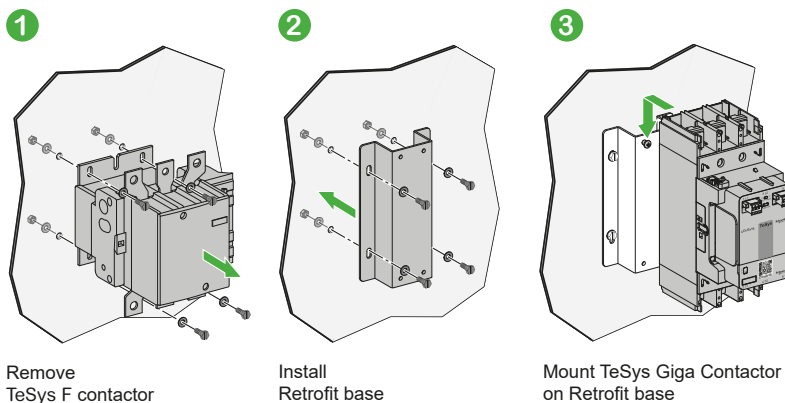

TeSys Giga retrofit bases are designed for integrating new TeSys Giga Contactors into installations using TeSys F contactors. The retrofit bases help reduce replacement and reinstallation time when you upgrade your system with the new range of contactors. The bases come in two frame sizes.

Retrofit bases

Description		Reference
Accessory used to replace TeSys F contactors	LC1F115-225 replaced by LC1G115-225	LA9GRFB1
	LC1F265-500 replaced by LC1G265-500	LA9GRFB2
	LC1F630-800 replaced by LC1G630-800	LA9GRFB3



LX1G3QLSEA



Control module replacement on a 3-pole contactor



LA9G81



LA9GRD10

Control module

Wide band electronic control
24 V...500 V 50/60 Hz or DC control input
Advanced and standard versions
Accessible from the front for easy and quick replacement

The control module is needed for the operation of the contactor. It performs the following functions:

- proper functioning of contactor based on the input control voltage
- monitoring and diagnostics of the pole condition
- generation of signaling commands.

The range of control modules is organized:

- per contactor size and for each rating,
- per control voltage range.

Each module has connectors for connecting:

- the coil control A1, A2 circuit & PLC output control (advanced version)
- pole status and diagnostic signaling circuits.

Control modules						
Description	For contactors	References per voltage range (V AC/DC)	References per voltage range			
			24 - 48	48 - 130	200 - 500	
Control modules for Advanced contactors	3-pole	LC1G115...LC1G225	LX1G3QBEEA	LX1G3QEHEA	LX1G3QLSEA	
		LC1G265...LC1G330	LX1G3RBEEA	LX1G3REHEA	LX1G3RLSEA	
		LC1G400...LC1G500	LX1G3SBEEA	LX1G3SEHEA	LX1G3SLSEA	
		LC1G630...LC1G800	-	LX1G3TEHEA	LX1G3TLSEA	
	4-pole	LC1G115...LC1G225	LX1G4QBEEA	LX1G4QEHEA	LX1G4QLSEA	
LC1G265...LC1G330		LX1G4RBEEA	LX1G4REHEA	LX1G4RLSEA		
LC1G400...LC1G500		LX1G4SBEEA	LX1G4SEHEA	LX1G4SLSEA		
LC1G630...LC1G800		-	LX1G4TEHEA	LX1G4TLSEA		
Control modules for Standard contactors	3-pole	LC1G115...LC1G225	LX1G3QEHEN	LX1G3QKUEN		
		LC1G265...LC1G330	LX1G3REHEN	LX1G3RKUEN		
		LC1G400...LC1G500	LX1G3SEHEN	LX1G3SKUEN		
		LC1G630...LC1G800	LX1G3TEHEN	LX1G3TKUEN		
	4-pole	LC1G115...LC1G225	LX1G4QEHEN	LX1G4QKUEN		
		LC1G265...LC1G330	LX1G4REHEN	LX1G4RKUEN		
		LC1G400...LC1G500	LX1G4SEHEN	LX1G4SKUEN		
		LC1G630...LC1G800	LX1G4TEHEN	LX1G4TKUEN		
				48 - 130	100 - 250	

Connector for control module		
Description		Reference
Push-in terminal connector for control module		LA9G81

Remote wear diagnostic (RWD) module		
Description		Reference
Remote wear diagnostic module for TeSys Giga Contactor - 1 NO		LA9GRD10 ⁽¹⁾
Remote wear diagnostic module for TeSys Giga Contactor - 1 NC		LA9GRD01 ⁽¹⁾

⁽¹⁾ Remote Wear Diagnostic (RWD) Module, can be installed and used only in Advanced version.

PB121588.eps



Switching module kits

Replaceable switching modules

- Innovative contact switching modules for TeSys Giga Contactors
- Replace worn-out poles with a new switching module in minutes, without having to disassemble the whole product
- No special tools are needed for the replacement.

TeSys Giga - Switching modules for TeSys Giga Contactors, Advanced and Standard versions

Description	For contactors	Quantity Set of	Reference
3 or 4 switching module kits	3-pole	LC1G115...LC1G225	3 LA9G3QA
		LC1G265...LC1G330	3 LA9G3RA
		LC1G400...LC1G500	3 LA9G3SA
		LC1G630...LC1G800	3 LA9G3TA
	4-pole	LC1G115...LC1G225	4 LA9G4QA
		LC1G265...LC1G330	4 LA9G4RA
		LC1G400...LC1G500	4 LA9G4SA
		LC1G630...LC1G800	4 LA9G4TA

Note: In the event of replacement, replace all switching modules. After replacement, change the position of RESET button on the control module from A to B or B to A.

Technical Data for Designers

Contents

TeSys Giga Contactors:

- > Characteristics 27 to 31
- > Dimensions 32 to 35
- > Diagrams 36

TeSys Control

Giga Contactors

Characteristics

Environment						
Contactor type			LC1G115... 225	LC1G265... 500	LC1G630... 800	
Rated insulation voltage (Ui)	Conforming to IEC 60947-4-1. Over-voltage category III, degree of pollution: 3		V	1000	1000	1000
Rated impulse withstand voltage (Uimp)	Coil not connected to the power circuit		kV	8	8	8
Conforming to standards				IEC/EN 60947-4-1, UL 60947-4-1, CSA C22.2 n° 60947-4-1, JIS C 8201-4-1, GB 14048.4, IEC 60721-3-3 3C3		
Product certifications				CB scheme, CCC, cULus, UKCA, EAC, EU-RO-MR by DNV-GL		
Electromagnetic compatibility				IEC 60947-4-1		
Immunity				Following IEC 60947-4-1 Table 14		
Emission				Environment A according to IEC 60947-4-1		
Immunity to radiated electromagnetic interference				20V/m according to IEC/EN 61000-4-3		
Voltage sag immunity (in complete product as well)				Conforming to SEMI-F47		
Degree of protection	Conforming to IEC 60529 / VDE 0106			IP2x with terminal shrouds LA9G37●●/ LA9G47●●		
Climatic withstand				According to IACS E10		
Ambient air temperature around the device	Storage		°C	-60...+80		
	Operation		°C	-25...+60		
	Permissible at Uc		°C	-40...+70		
Net weight	Standard	3P	kg	3.6	7.5	14.2
		4P	kg	4.4	8.2	18
	Advanced	3P	kg	4.1	8.2	17.3
		4P	kg	5.1	8.7	22
Maximum operating altitude	Without derating		m	3000		
Operating positions	Without derating					
	With derating					
Shock resistance 1/2 sine wave = 11 ms Conforming to IEC 60068-2-7	Contactor open			10 gn	10 gn	10 gn
	Contactor closed			15 gn	15 gn	15 gn
Vibration resistance 5...300 Hz Conforming to IEC 60068-2-6	Contactor open			2 gn	2 gn	2 gn
	Contactor closed			4 gn	4 gn	4 gn

TeSys Control

Giga Contactors

Characteristics

Pole characteristics						
Contactor type			LC1G115	LC1G150	LC1G185	LC1G225
Number of poles			3 or 4	3 or 4	3 or 4	3 or 4
Rated operational current (Ie)	In AC-3 / AC-3e ≤ 60 °C	A	115 / 115	150 / 145	185 / 177	225 / 209
	In AC-1, θ ≤ 40 °C	A	250	275	305	330
Rated operational voltage (Ue) ⁽¹⁾	Up to	V	1000	1000	1000	1000
Rated frequency (f) ⁽²⁾		Hz	50 / 60	50 / 60	50 / 60	50 / 60
Frequency operating limits	With derating	Hz	16 ^{2/3} ...400	16 ^{2/3} ...400	16 ^{2/3} ...400	16 ^{2/3} ...400
Conventional thermal current	θ ≤ 40 °C	A	250	275	305	330
Rated making capacity	I rms conforming to IEC 60947-4-1	A	Making current: 10 x I in AC-3 or 12 x I in AC-4 Making current: 13 x I in AC-3e			
Rated breaking capacity	I rms conforming to IEC 60947-4-1	A	Making and breaking current: 8 x I in AC-3 or 10 x I in AC-4 Making and breaking current: 8.5 x I in AC-3e			
Maximum permissible current No current flowing for previous 60 minutes, at θ ≤ 40 °C	For 10 s	A	1100	1200	1500	1800
	For 30 s	A	640	700	920	1000
	For 1 min	A	520	600	740	850
	For 3 min	A	400	450	500	560
	For 10 min	A	320	350	400	440
Short-circuit protection by fuses	Fuses for motor: type aM - Ue ≤ 440 V	A	125	160	200	250
	Fuses for motor: type aM - Ue ≤ 690 V	A	125	160	160	200
	Fuses for general application: type gL - Ue ≤ 690 V	A	315	315	315	400
Average impedance per pole	At Ith and 50 Hz	mΩ	0.18	0.18	0.17	0.15
Power dissipation per pole for the above operational currents	AC-3 / AC-3e	W	3	5	6	8
	AC-1	W	10	10	20	20
Connection	Bar		Maximum c.s.a.			
	Number of bars		2	2	2	2
	Bar	mm	25 x 6	25 x 6	25 x 6	25 x 6
	Cable with lug	mm²	185	185	185	185
	Cable with connector	mm²	185	185	185	185
Bolt diameter	mm	Ø8.5	Ø8.5	Ø8.5	Ø8.5	
Tightening torque	Power circuit connections	N.m	18	18	18	18

(1) Ue = 1000 V Simple Insulation / Ue = 690 V SELV.

(2) Please consult your technical support team for application with frequencies other than 50/60 Hz.

TeSys Control

Giga Contactors





Characteristics

Pole characteristics					
LC1G265	LC1G330	LC1G400	LC1G500	LC1G630	LC1G800
3 or 4	3 or 4	3 or 4	3 or 4	3 or 4	3 or 4
265 / 255	330 / 294	400 / 391	500 / 437	630 / 555	800 / 587
385	440	550	700	1050	1050
1000	1000	1000	1000	1000	1000
50 / 60	50 / 60	50 / 60	50 / 60	50 / 60	50 / 60
16 ^{2/3} ...400	16 ^{2/3} ...400	16 ^{2/3} ...400	16 ^{2/3} ...400	16 ^{2/3} ...400	16 ^{2/3} ...400
385	440	550	700	1050	1050
Making current: 10 x I in AC-3 or 12 x I in AC-4					
Making current: 13 x I in AC-3e					
Making and breaking current: 8 x I in AC-3 or 10 x I in AC-4					
Making and breaking current: 8.5 x I in AC-3e					
2200	2650	3600	4000	5050	5500
1230	1800	2400	2800	4400	4600
950	1300	1700	2200	3400	3600
620	900	1200	1500	2200	2600
480	750	1000	1200	1600	1700
315	400	500	500	630	800
250	250	315	400	500	630
400	500	630	800	1250	1250
0.144	0.144	0.1	0.08	0.065	0.065
11	16	16	20	26	42
20	30	30	40	70	70
Maximum c.s.a.					
2	2	2	2	2	2
32 x 10	32 x 10	32 x 10	32 x 10	52 x 20	52 x 20
240	2 x 150	2 x 185	2 x 240	-	-
240	-	-	-	-	-
Ø10.6	Ø10.6	Ø10.6	Ø10.6	Ø13	Ø13
35	35	35	35	58	58

TeSys Control

Giga Contactors

Characteristics





TeSys Giga contactors - Advanced version - Control circuit characteristics with AC/DC coils								
Contactor type				LC1G115...225	LC1G265...330	LC1G400...500	LC1G630...800	
Rated control circuit voltage (Uc)				V	24...48 AC/DC, 48...130 AC/DC, 200...500 AC/DC ⁽¹⁾			
Control voltage limits (θ ≤ 60 °C)	AC input (50/60 Hz) /DC input	Operation			0.8 Uc Min...1.1 Uc Max			
		Drop-out			0.1 Uc Max...0.45 Uc Min			
Inputs compatibility PLC digital output 24 V DC Type 3 IEC61131-2	Off-state		V DC	0...5				
	On-state		V DC	11...30				
Average consumption at 20 °C and at Uc (3 and 4-pole contactors)	24...48 V AC/DC coil (BEE)	Inrush	50/60 Hz coil	VA	290	540	490	-
			DC	W	220	380	350	-
		Sealed	50/60 Hz coil	VA	10	17.9	17.9	-
			DC	W	5.7	6.4	6	-
	48...130 V AC/DC coil (EHE)	Inrush	50/60 Hz coil	VA	260	430	450	560
			DC	W	190	360	360	440
		Sealed	50/60 Hz coil	VA	8.9	11.7	11.7	12
			DC	W	5	9	8.3	8.8
	200...500 V AC/DC coil (LSE)	Inrush	50/60 Hz coil	VA	295	530	535	670
			DC	W	215	300	300	390
		Sealed	50/60 Hz coil	VA	13	16.1	15.4	17
			DC	W	8	9	8.6	11
Heat dissipation				W	4...5	5...6	5...6	5...6
Operating time	Closing "C"		ms	40...70	40...70	40...70	40...70	
	Opening "O"		ms	15...50	15...50	15...50	15...50	
Mechanical durability at Uc		In millions of operating cycles (max)			8	8	8	5
Maximum operating rate at ambient temperature ≤ 60 °C	In operating cycles per hour	AC-1			300	300	300	300
		AC-3			500	500	500	500
		AC-4			150	150	60	60
Coil control and PLC input connection (Push-in type)					Min/max c.s.a.			
Flexible cable	1 conductor with cable end		mm² 	0.25...2.5	0.25...2.5	0.25...2.5	0.25...2.5	
	2 conductors with Dual Sleeve		mm² 	0.5...1	0.5...1	0.5...1	0.5...1	
Solid cable	1 conductor		mm² 	0.2...2.5	0.2...2.5	0.2...2.5	0.2...2.5	
	Stripping length		mm 	12	12	12	12	

(1) 24...48 V AC/DC control voltage option is available for LC1G115...LC1G500 ratings.

TeSys Control

Giga Contactors

Characteristics

TeSys Giga Contactors - Standard version control circuit characteristics with AC/DC coils					LC1G115...225	LC1G265...330	LC1G400...500	LC1G630...800
Rated control circuit voltage (Uc)				V	48...130 AC/DC, 100...250 AC/DC			
Control voltage limits ($\theta \leq 60^\circ\text{C}$)	AC input (50/60 Hz) /DC input	Operation			0.8 Uc Min...1.1 Uc Max ⁽¹⁾			
		Drop-out			0.1 Uc Max...0.45 Uc Min			
Average consumption at 20 °C and at Uc (3 and 4-pole contactors)	48...130 V AC/DC coil (EHE)	Inrush	50/60 Hz coil	VA	640	780	965	990
			DC	W	445	695	760	790
		Sealed	50/60 Hz coil	VA	18.7	17.6	17.6	18.7
			DC	W	7.8	7.8	7.8	9.5
	100...250 V AC/DC coil (KUE)	Inrush	50/60 Hz coil	VA	540	700	750	800
			DC	W	380	645	660	680
		Sealed	50/60 Hz coil	VA	12.4	15	15.5	15
			DC	W	7.8	9.1	9.3	9.5
Heat dissipation				W	5...6	6...7	6...7	6...7
Operating time	Closing "C"			ms	40...70	40...70	40...70	40...70
	Opening "O"			ms	15...50	15...50	15...50	15...50
Mechanical durability at Uc	In millions of operating cycles (max)				8	8	8	5
Maximum operating rate at ambient temperature $\leq 60^\circ\text{C}$	In operating cycles per hour	AC-1			300	300	300	300
		AC-3			500	500	500	500
		AC-4			150	150	60	60
Coil control connection (Push-in type)					Min/max c.s.a.			
Flexible cable	1 conductor with cable end		mm²		0.25...2.5	0.25...2.5	0.25...2.5	0.25...2.5
	2 conductors with Dual Sleeve		mm²		0.5...1	0.5...1	0.5...1	0.5...1
Solid cable	1 conductor		mm²		0.2...2.5	0.2...2.5	0.2...2.5	0.2...2.5
	Stripping length		mm		12	12	12	12

(1) 0.7 Uc Min for 110 V DC input (with KUE coil).

TeSys Control

Giga Contactors

Dimensions

Advanced LC1G115...225 TeSys Giga Contactors

3-pole

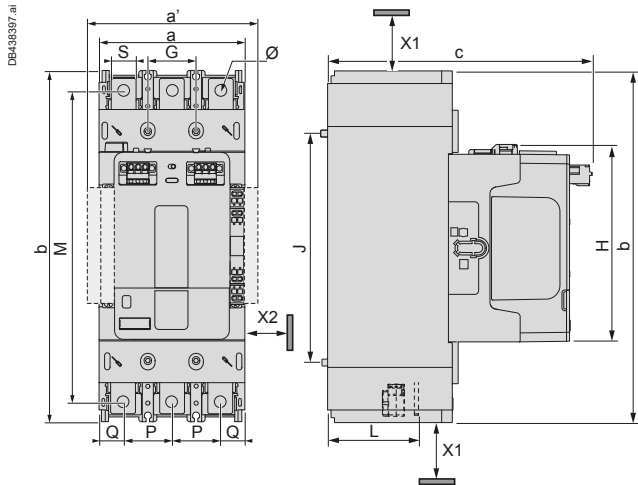

All dimensions are in mm.

a	b	c	G	J	M	H	L	P	Q	S	Ø
108	255	193	35	166	226	145	67	35	19	18	8.5

X1 (mm) = Minimum electrical clearance.

LC1G115...800, up to 1000 V: 40 mm

X2 (mm) = Minimum electrical clearance according to operating voltage inside metallic cabinets / adjacent installation of contactors.

LC1G115...800, up to 600 V: 5 mm

a' = a + 20 mm with additional auxiliary contact blocks on both sides (externally).

4-pole

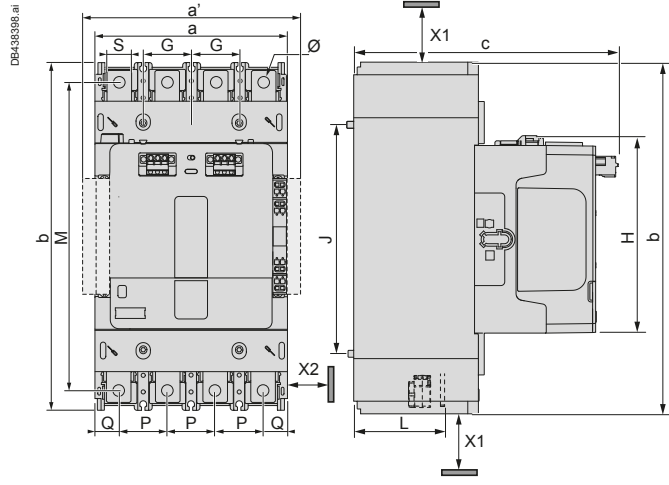

All dimensions are in mm.

a	b	c	G	J	M	H	L	P	Q	S	Ø
143	255	193	70	166	226	145	67	35	19	18	8.5

Standard LC1G115...225 TeSys Giga Contactors

3-pole

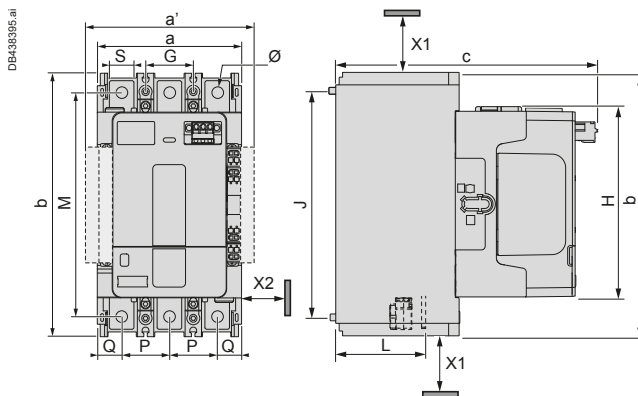

All dimensions are in mm.

a	b	c	G	J	M	H	L	P	Q	S	Ø
108	193	193	35	166	164	145	70	35	19	18	8.5

X1 (mm) = Minimum electrical clearance.

LC1G115...800, up to 1000 V: 40 mm

X2 (mm) = Minimum electrical clearance according to operating voltage inside metallic cabinets / adjacent installation of contactors.

LC1G115...800, up to 600 V: 5 mm

a' = a + 20 mm with additional auxiliary contact blocks on both sides (externally).

4-pole

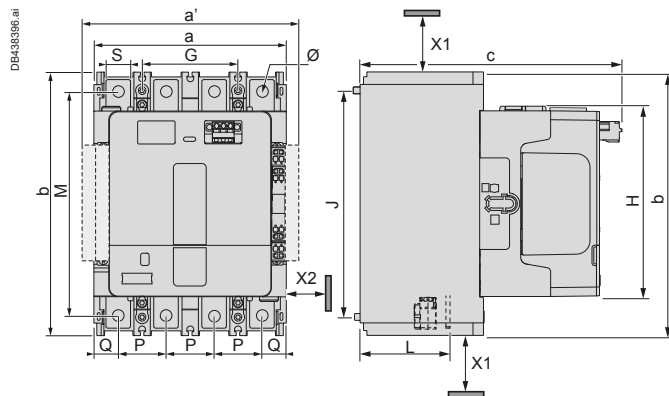

All dimensions are in mm.

a	b	c	G	J	M	H	L	P	Q	S	Ø
143	193	193	70	166	164	145	70	35	19	18	8.5

TeSys Control Giga Contactors

Dimensions

Advanced LC1G265...500 TeSys Giga Contactors

3-pole

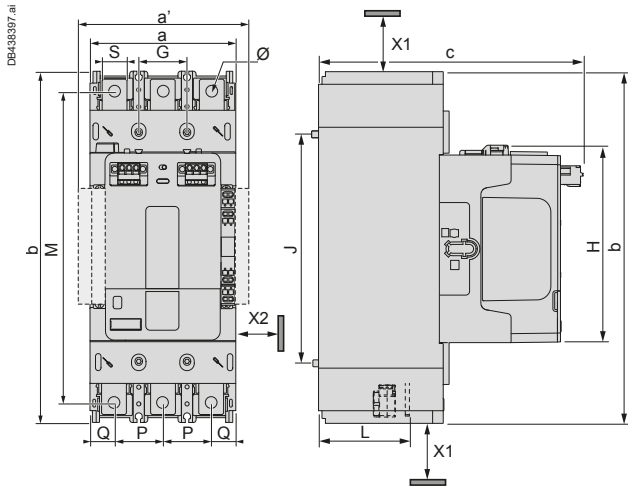

4-pole

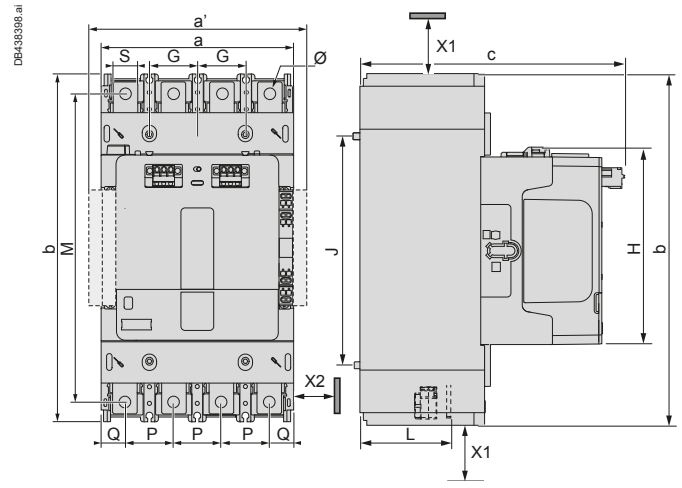

All dimensions are in mm.

a	b	c	G	J	M	H	L	P	Q	S	Ø
140	290	225	45	187	262	167	79	45	25	30	10.6

All dimensions are in mm.

a	b	c	G	J	M	H	L	P	Q	S	Ø
185	290	225	90	187	262	167	82	45	25	30	10.6

X1 (mm) = Minimum electrical clearance.

LC1G115...800, up to 1000 V: 40 mm.

X2 (mm) = Minimum electrical clearance according to operating voltage inside metallic cabinets / adjacent installation of contactors.

LC1G115...800, up to 600 V: 5 mm

a' = a + 20 mm with additional auxiliary contact blocks on both sides (externally).

Standard LC1G265...500 TeSys Giga Contactors

3-pole

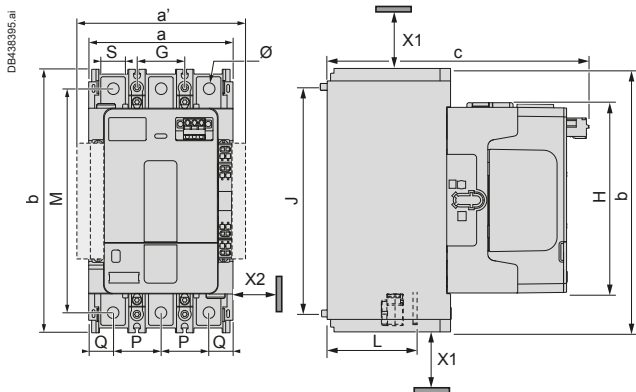

4-pole

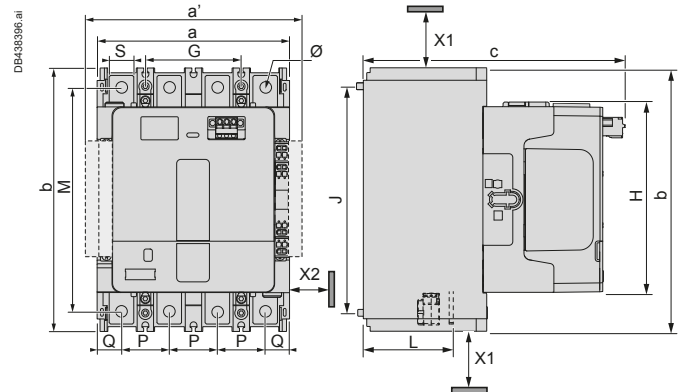

All dimensions are in mm.

a	b	c	G	J	M	H	L	P	Q	S	Ø
140	225	225	45	187	197	167	82	45	25	30	10.6

All dimensions are in mm.

a	b	c	G	J	M	H	L	P	Q	S	Ø
185	225	225	90	187	197	167	82	45	25	30	10.6

X1 (mm) = Minimum electrical clearance.

LC1G115...800, up to 1000 V: 40 mm.

X2 (mm) = Minimum electrical clearance according to operating voltage inside metallic cabinets / adjacent installation of contactors.

LC1G115...800, up to 600 V: 5 mm

a' = a + 20 mm with additional auxiliary contact blocks on both sides (externally).

TeSys Control

Giga Contactors

Dimensions

Advanced LC1G630...800 TeSys Giga Contactors

3-pole

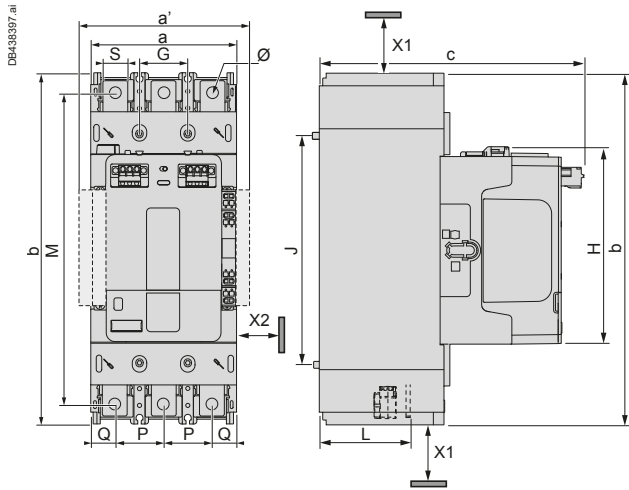

All dimensions are in mm.

a	b	c	G	J	M	H	L	P	Q	S	Ø
210	388.5	265	70	242	346.5	192	107	70	35.3	48	13

X1 (mm) = Minimum electrical clearance.

LC1G115...800, up to 1000 V: 40 mm.

X2 (mm) = Minimum electrical clearance according to operating voltage inside metallic cabinets / adjacent installation of contactors.

LC1G115...800, up to 600 V: 5 mm

a' = a with additional auxiliary contact blocks on both sides (externally).

4-pole

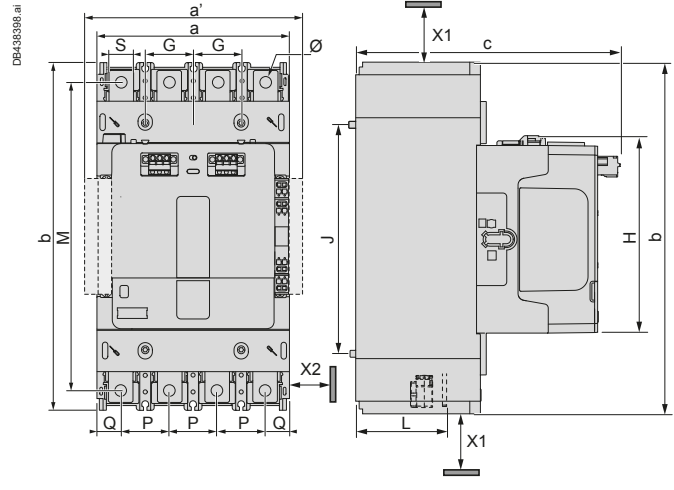

All dimensions are in mm.

a	b	c	G	J	M	H	L	P	Q	S	Ø
280	388.5	265	140	242	346.5	192	107	70	35.3	48	13

Standard LC1G630...800 TeSys Giga Contactors

3-pole

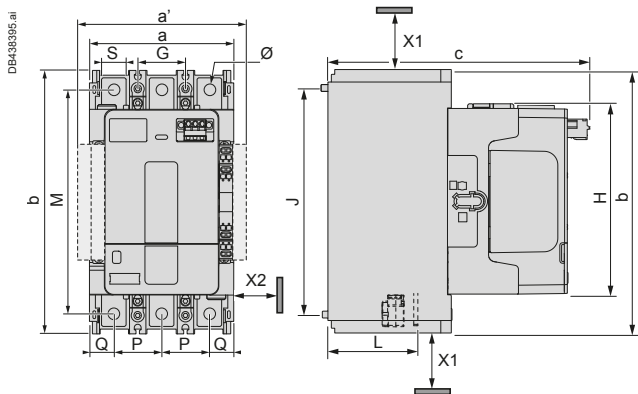

All dimensions are in mm.

a	b	c	G	J	M	H	L	P	Q	S	Ø
210	284	265	70	242	244	192	107	70	35.3	48	13

X1 (mm) = Minimum electrical clearance.

LC1G115...800, up to 1000 V: 40 mm.

X2 (mm) = Minimum electrical clearance according to operating voltage inside metallic cabinets / adjacent installation of contactors.

LC1G115...800, up to 600 V: 5 mm

a' = a with additional auxiliary contact blocks on both sides (externally).

4-pole

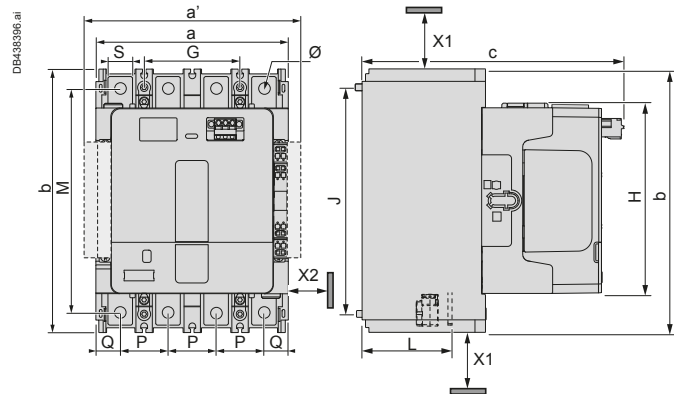

All dimensions are in mm.

a	b	c	G	J	M	H	L	P	Q	S	Ø
280	284	265	140	242	244	192	107	70	35.3	48	13

TeSys Control

Retrofit base plates to replace TeSys F contactors

Dimensions/mounting

Dimensions

LA9GRBF1

For replacement of F115-225

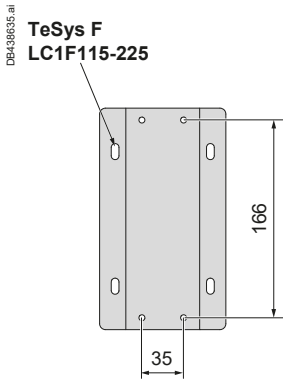

LA9GRBF2

For replacement of F265-500

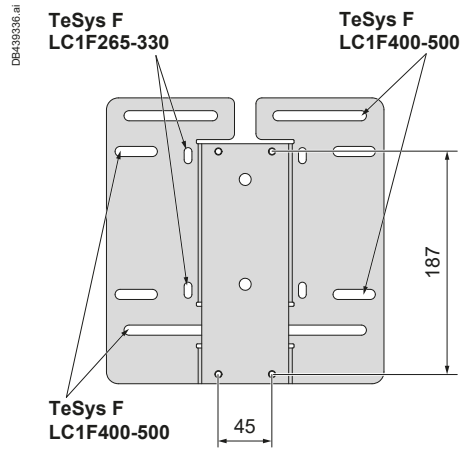

LA9GRBF3

For replacement of F630 and F800

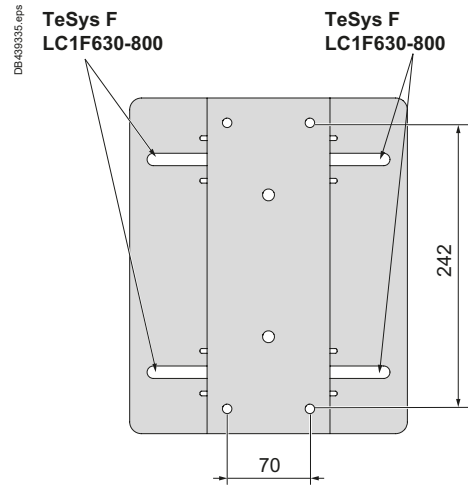

Note: All dimensions are in mm.

TeSys Control

Giga Contactors

Diagrams

TeSys Giga Contactors

Advanced version - ON/OFF control by PLC

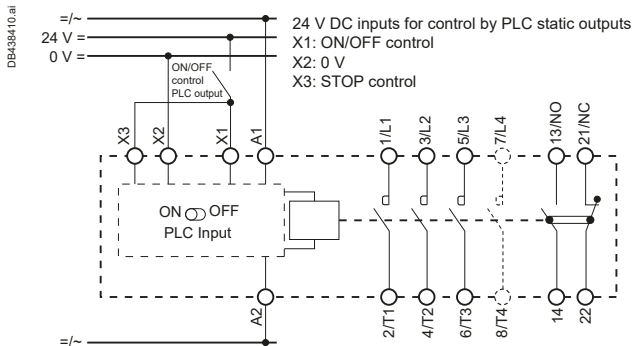

Advanced version - ON/OFF control by PLC in safety application

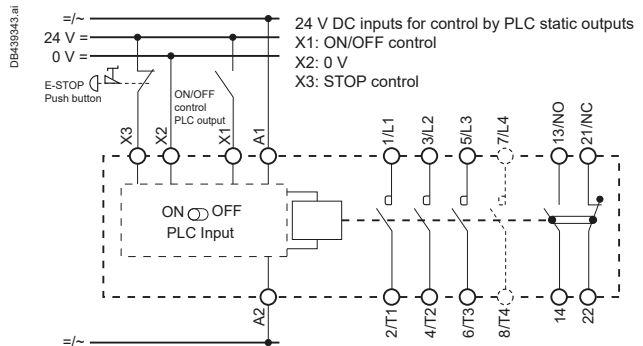

Advanced version - Control by switch

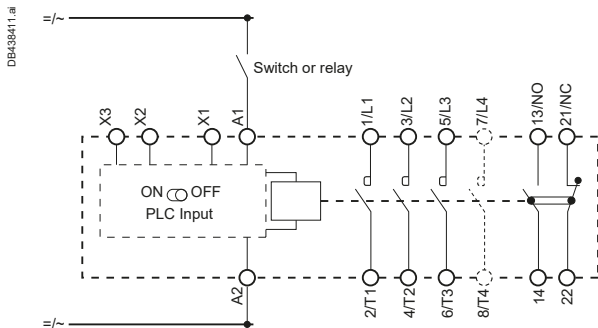

Standard version

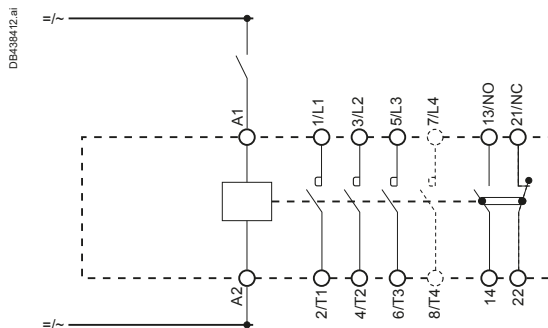

Add-on blocks

Instantaneous auxiliary contacts

1 N/O + 1 N/C

LAG8N113P
mirror contacts

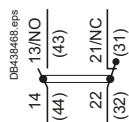

2 N/O

LAG8N203P

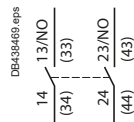

1 N/O + 1 N/C

LAG8N113
mirror contacts

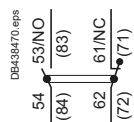

2 N/O

LAG8N203

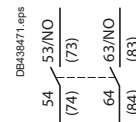

(1) Terminal numbers in brackets refer to blocks when mounted upside down, on left-hand side of contactor.

TeSys Protect

Giga Electronic Overload Relays

TeSys Giga Electronic Overload Relays		
Type of product	Range	Pages
Introduction		38
Overload relays for TeSys Giga Contactors TeSys Giga Electronic Overload Relays	From 28 to 630 A	40
Accessories TeSys Giga Electronic Overload Relays		40
Technical Data for Designers		43



TeSys Protect

Giga Electronic Overload Relays

Introduction

> Intelligent design for greater advantages

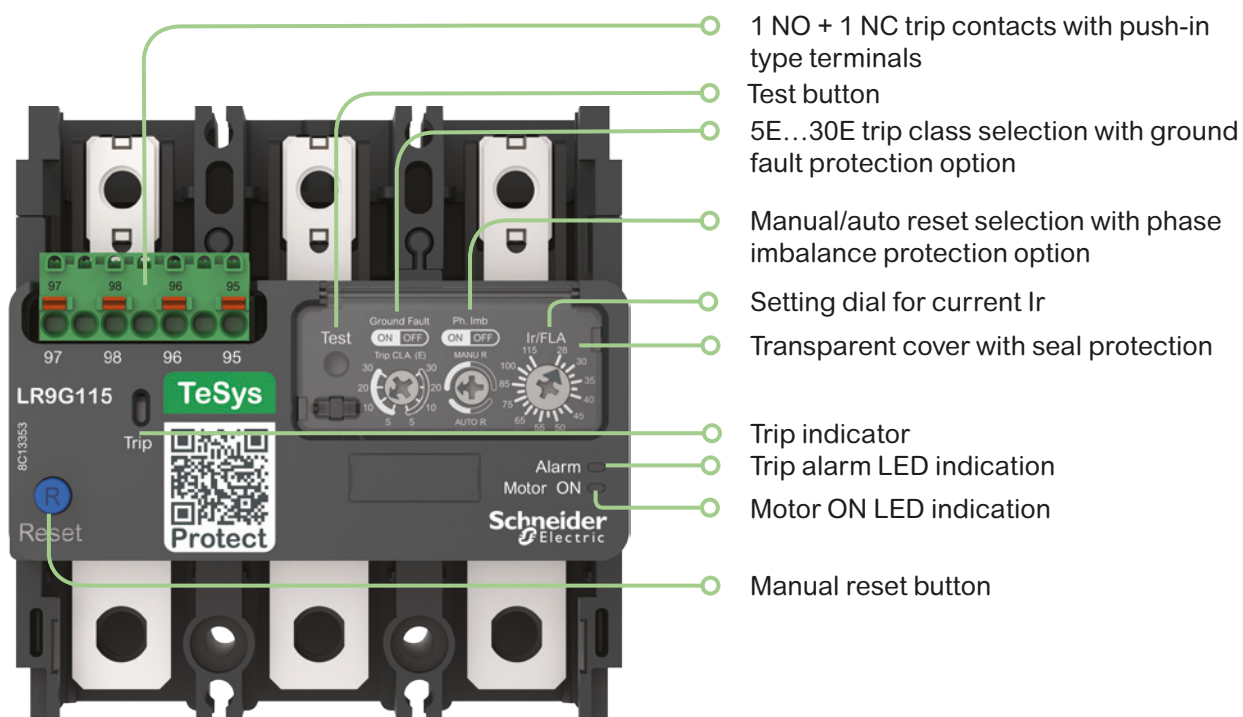
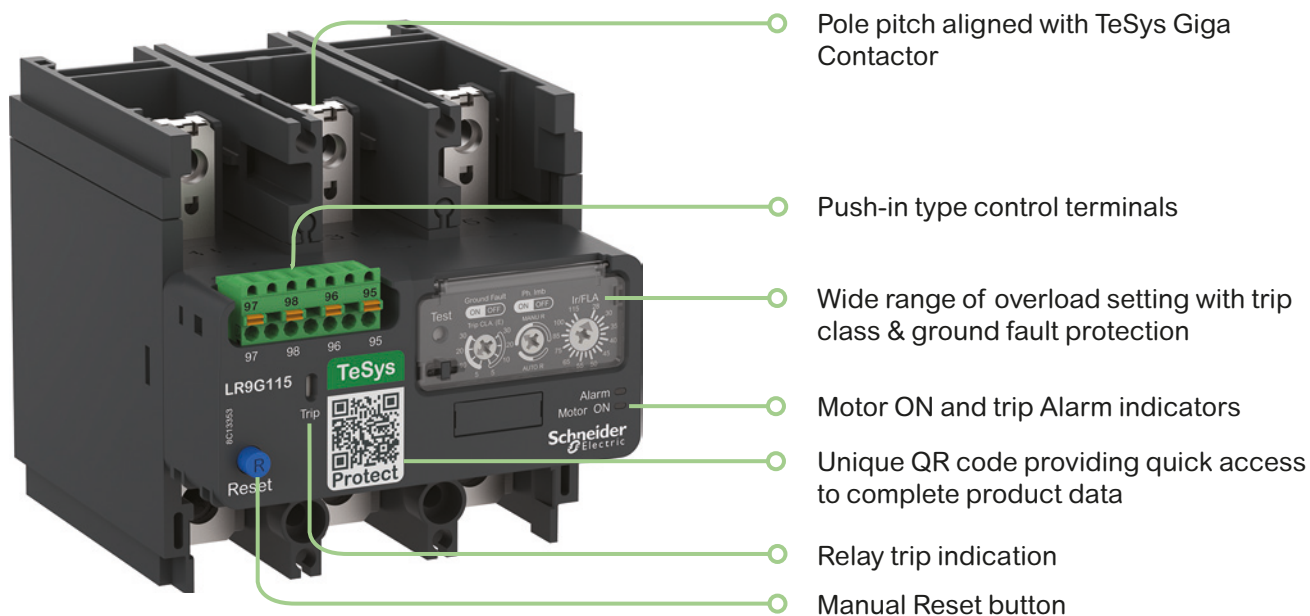

TeSys Protect

Giga Electronic Overload Relays

Description

> Perfect selection for your motor protection

Range

- A comprehensive range of TeSys Giga Electronic Overload Relays in 3 sizes
- Direct mounting of relay with contactors saving in panel space and installation time



28...115 A and 57...225 A



125...500 A



160...630 A

Overload relays

- Advanced electronic monitoring with high accuracy
- Thermal compensation for ambient temperatures up to 60 °C
- Wide range of current settings, 0.25...1 I_r setting
- Direct and separately mountable to manage panel design
- Pole pitch alignment with contactors, enabling direct mounting
- Push-in terminals for quick and easy control wiring options
- 4 references covering the complete range means less inventory
- Manual and auto reset to suit your needs
- Multiple reset options: Manual, Automatic & Remote
- Protection against phase loss
- Selectable protection against imbalanced load
- Selectable protection against ground fault
- ON status and overload alarm signaling by LED
- TRIP indicator

Certifications

- Multiple standards
- International certifications

Trip class

- Selectable, from class 5E to class 30E to suit different application needs

TeSys Protect

Giga Electronic Overload Relays

Product references



LR9G225



Direct mounting
with TeSys Giga Contactor



LA9G3650



LA9G82



LA9G3704

TeSys Giga Electronic Overload Relays

- Electronic overload relay
- Suitable for independent mounting or direct mounting with TeSys Giga contactors
- Ergonomic rotary switches for thermal and protection settings
- Trip class selection: 5E/10E/20E/30E
- Overload, phase imbalance, phase loss and ground fault protections
- Manual and auto reset options
- LED indicator for Motor ON and pre-trip alarm
- Thermal memory and compensation
- Push-in terminals for control connections

Relay setting range	Fuses to be used with selected relay		For direct mounting beneath contactor LC1G	Reference
	aM /gG/aR	kA		
A	A			
Class 5E...30E				
28...115	125 aM	100	LC1G115...225	LR9G115
57...225	250 aM	100	LC1G115...225	LR9G225
125...500	630 aM	100	LC1G265...500	LR9G500
	630 gG	80		
	630 aR	25		
160...630	800 aR	100	LC1G630	LR9G630
	800 aR	80		
	800 aR	25		

Overload Relay accessories

Mounting and wiring accessories

Description	Reference
Mounting base for alignment of LR9G115-225 with LC1G115-225 ⁽²⁾	LA9G3650
Mounting base for alignment of LR9G500 with LC1G265-330 ⁽²⁾	LA9G3651
Mounting base for alignment of LR9G500 with LC1G400-500 ⁽²⁾	LA9G3652
Mounting base for alignment of LR9G630 with LC1G630-800 ⁽²⁾	LA9G3653
Push-in connection adapter	LA9G82

Front protection cover

Description	Compatible with contactors	Quantity	Reference
Front protection cover ⁽³⁾	LR9G115 / LR9G225	1	LA9G3704
	LR9G500	1	LA9G3705
	LR9G630	1	LA9G3706

⁽²⁾ Used for independent mounting of Overload Relay beneath contactor to align main power pole connections.
⁽³⁾ Used to cover main power connection terminals between contactor and overload with direct mounting option.

TeSys Protect

Giga Electronic Overload Relays

Product references



LAD703●

Remote Reset control device

Description	Quantity	Reference
Remote electrical reset device ⁽¹⁾	1	LAD703● ⁽²⁾
Remote Reset function control by flexible cable (length = 0.5 m)	1	LAD7305

⁽¹⁾ The time for which the coil of remote electrical reset device LAD703● can remain energised depends on its rest time: 1 s pulse duration with 9 s rest time; 5 s pulse duration with 30 s rest time; 10 s pulse duration with 90 s rest time. Maximum pulse duration of 20 s with rest time of 300 s. Minimum pulse time: 200 ms.

⁽²⁾ Reference to be completed by adding the coil voltage code.



LAD7305

Standard control circuit voltages

Volts	24	110	220/230
~ 50/60 Hz	B	F	M
Consumption, inrush and sealed: < 100 VA			
---	B	F	M
Consumption, inrush and sealed: < 100 W.			

TeSys Protect - Giga

Technical Data for Designers

Contents

TeSys Giga Electronic Overload Relays:

- > Characteristics..... 44 to 46
- > Dimensions, diagram 47

TeSys Protect

Giga Electronic Overload Relays

Characteristics





Environment					
Contactor type		LR9G115	LR9G225	LR9G500	LR9G630
Conforming to standards		IEC/EN 60947-4-1, IEC/EN 60947-5-1, UL 60947-4-1, CSA C22.2 n° 60947-4-1, UL 60947-5-1, CSA C22.2 n° 60947-5-1, GB/T 14048.4			
Product certifications		CB Scheme, CCC, cULus, UKCA, ATEX, EU-RO-MR by DNV-GL			
Degree of protection	Conforming to IEC 60529 / VDE 0106	IP 20 on front of relay with accessories LA9G37●●			
Climatic withstand		according to IACS E10			
Ambient air temperature around the device (conforming to IEC 60255-8)	Storage	°C	-55...+80		
	Normal operation	°C	-25...+60		
Maximum operating altitude	Without derating	m	3000		
Net weight		kg	1.2	1.7	2.8
Operating positions without derating	In relation to normal vertical mounting plane	Any position			
Shock resistance 11 ms	Permissible acceleration conforming to IEC 60068-2-7	15 gn			
Vibration resistance 5 to 300 Hz	Permissible acceleration conforming to IEC 60068-2-6	6 gn			
Rated impulse withstand voltage (Uimp)	Conforming to IEC 60947-4-1	kV	8		
Surge withstand	Conforming to IEC 61000-4-5	kV	4		
Resistance to electrostatic discharge	Conforming to IEC 61000-4-2	kV	8 (in air) 6 (in direct mode)		
Resistance to radiated radio-frequency disturbance	Conforming to IEC 61000-4-3	V/m	20		
Resistance to fast transient currents	Conforming to IEC 61000-4-4	kV	4		
Electromagnetic compatibility		EN 50081-1 and 2, EN 50082-2			

TeSys Protect

Giga Electronic Overload Relays

Characteristics

Power circuit - Electrical characteristics				LR9G115	LR9G225	LR9G500	LR9G630
Relay type							
Rated insulation voltage (Ui)	Conforming to IEC 60947-4-1 Over-voltage category III, degree of pollution: 3	V	1000				
Rated impulse withstand voltage (Uimp)	Conforming to IEC 60947-1	kV	8				
Rated operational current (Ie)		A	28 to 630				
Short-circuit protection and coordination			See pages 54 to 57 and 62 to 64				
Frequency limits of the operating current		Hz	50 / 60				
Power circuit connections	Width of terminal lug	mm	18	18	30	48	
	Clamping screw		M8	M8	M10	M12	
	Tightening torque	N.m	18	18	35	58	

Auxiliary contact electrical characteristics									
Conventional thermal current		A	5						
Short-circuit protection	By gG fuses	A	6						
Connection (Push-in type)			Min.	Max.					
Flexible cable	1 conductor with cable end	mm ² 	0.25	2.5					
	2 conductors with Dual Sleeve	mm ² 	0.5	1					
Solid cable	1 conductor	mm ² 	0.2	2.5					
	Stripping length	mm 	10	10					
Rated operational contact power	a.c. supply AC-15	V	24	48	120	240	380	480	500
		A	4	4	3	1.5	0.95	0.75	0.72
		VA	96	192	360	360	361	360	360
	d.c. supply DC-13	V	24	48	125	250	–	–	–
		A	2	0.7	0.22	0.11	–	–	–
		W	48	33.6	27.5	27.5	–	–	–
Maximum operational voltage	a.c., category AC-15	V	500	500	500	500	500	500	
	d.c., category DC-13	V	250	250	250	250	250	250	

TeSys Protect

Giga Electronic Overload Relays

Characteristics

Operating characteristics

Tripping class	Conforming to IEC 60947-4-1		5E/10E/20E/30E
Operating temperature		°C	-40...+60 ⁽¹⁾
Reset			auto and manual
Trip alarm and fault indication			On front of relay
Test function			On front of relay
Tripping thresholds	Conforming to IEC 60947-4-1	Alarm Tripping	≥ 90% of permissible thermal state 1.2 ± 0.05 I _r
Sensitivity to phase loss	Conforming to IEC 60947-4-1		Tripping in 4 s ± 20 % in the event of phase loss
Phase imbalance	Conforming to IEC 60947-1		Tripping in 5 s ± 20 % if imbalance ratio ≥ 40 % according to Annex T5.5
Ground fault	Conforming to IEC 60947-4-1		I _g = 0.75 I _r Tripping 1 s ± 20 % if I ≥ 1.1 I _g
Adjustment (nominal motor current)			Setting dial on front of relay (64 settings)
Security sealing			Yes

(1) Adjustment of dial setting(s): -25...+60 °C.

LR9G tripping curves

Average operating times depending on multiples of the setting current

Class 5E

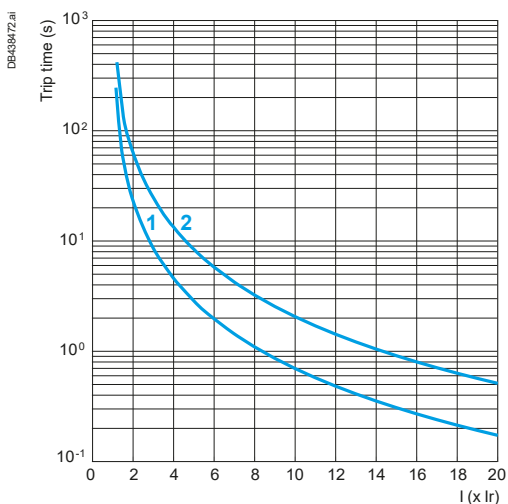

- 1 Hot state
- 2 Cold state

Class 10E

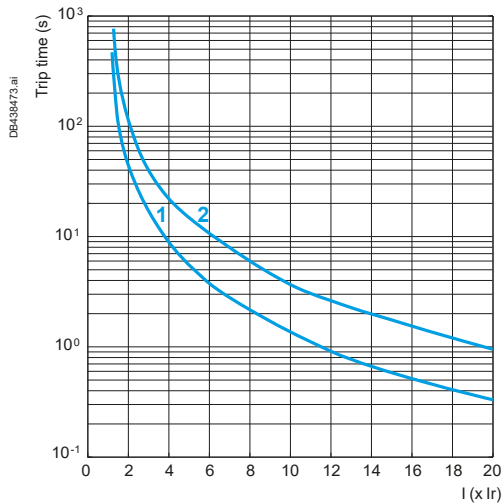

- 1 Hot state
- 2 Cold state

Class 20E

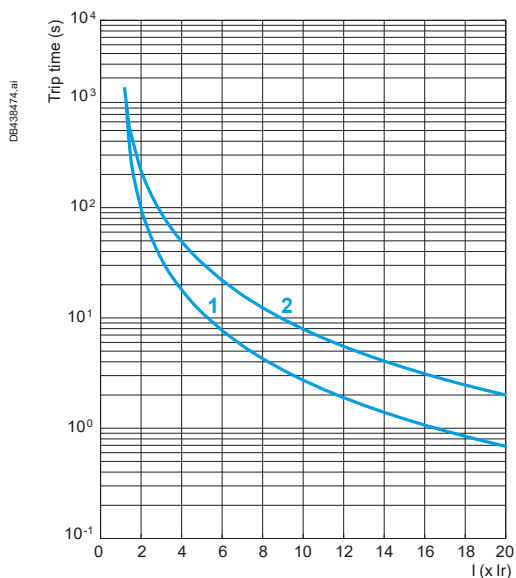

- 1 Hot state
- 2 Cold state

Class 30E

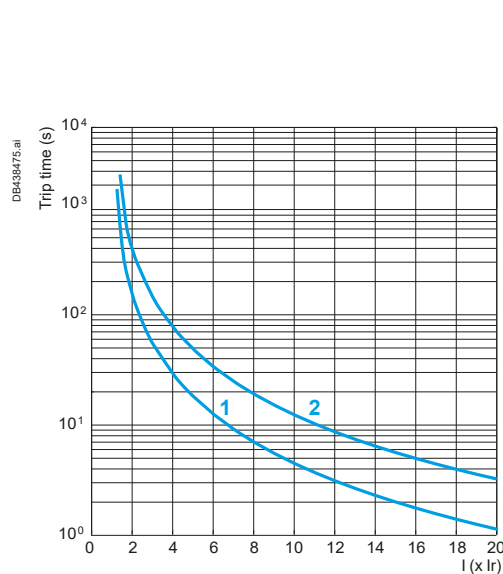

- 1 Hot state
- 2 Cold state

TeSys Protect

Giga Electronic Overload Relays

Dimensions and diagram

Dimensions

LR9G115...630

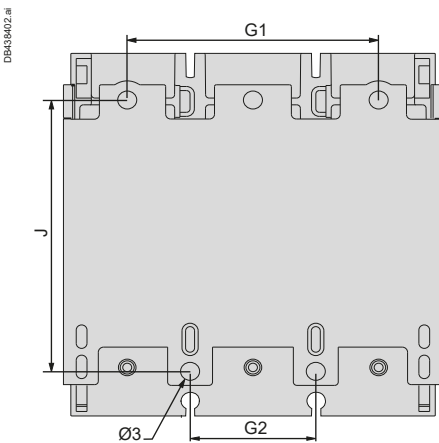
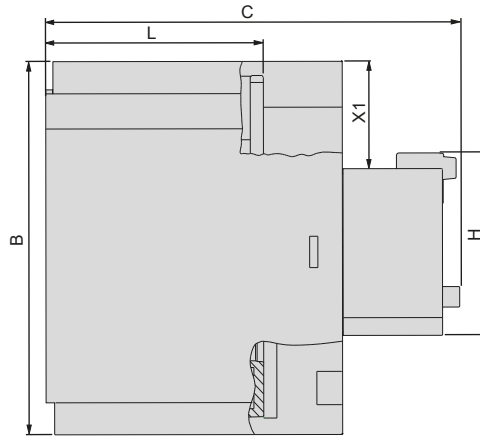
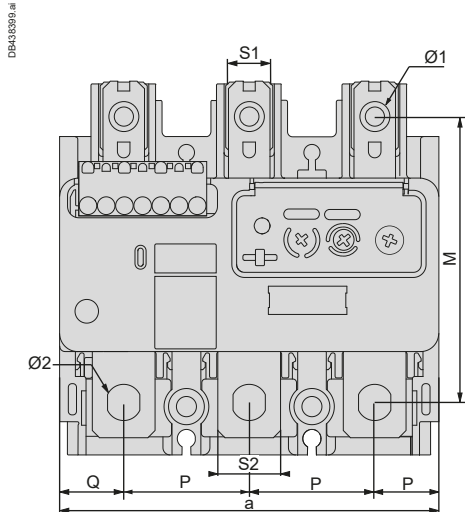

LR9G	115-225	500	630
a	105.7	140	210
b	109.55	115.65	149.45
c	126.2	139.2	185.9
G1	70	119.3	186.2
G2	35	45	70
J	80.1	68.25	86
M	78	83	100
H	52	52	52
L	66	79	107
P	35	45	70
Q	18	25	35
S1	11.5	22.5	22.5
S2	17.5	30.5	50
Ø1	8.3	10.6	13
Ø2	9	10.6	13
Ø3	5.3	5.3	8.5
X1	30	33	50

Diagram

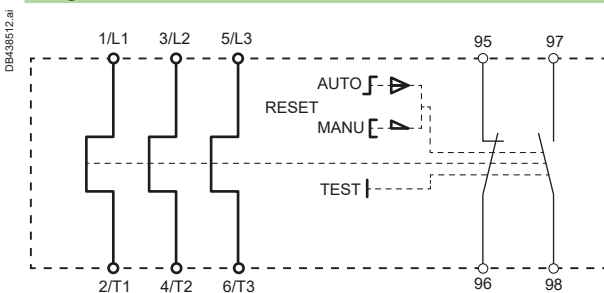

Coordination tables

Content	Pages
Coordination for D.O.L. / Reverser motor starters	50
Optimized solutions for Star-Delta motor starters	59
Star-Delta motor starter - Common circuit diagrams	65
Resistive load protection and control	66

TeSys Giga Contactors for various applications

Utilisation category AC-3	68
Utilisation category AC-1	70
Utilisation category AC-2 or AC-4	71
Utilisation category DC-1 to DC-5	73
Heating	74
Power factor correction	76

TeSys Giga series – Device selection

Coordination tables

Coordination for D.O.L. / Reverser motor starters

Thermal magnetic circuit breakers + Contactors

45 to 250 kW at 400 V: type 2 coordination (with TeSys GV4/GV5/GV6 circuit breakers)						
Standard power ratings of 3-phase motors 50/60 Hz in category AC-3e			Circuit breaker			Contactor
400 V			Product type ⁽¹⁾	Ir setting ⁽²⁾	Irm ⁽²⁾	Product type
P	Ie	Iq (max)				
kW	A	kA		A	A	
45	80	100	GV4P/GV4PE/GV4PEM115●	86	1118	LC1G115
55	97	100	GV4P/GV4PE/GV4PEM115●	100	1300	LC1G115
55	97	70	GV5P150●	100	1300	LC1G115
75	132	70	GV5P150●	140	1820	LC1G150
90	160	70	GV5P220●	170	2210	LC1G185
110	195	70	GV5P220●	200	2600	LC1G225
110	195	70	GV6P320●	200	2600	LC1G265
132	230	70	GV6P320●	240	3120	LC1G265
160	280	70	GV6P320●	300	3900	LC1G330
200	350	70	GV6P500●	380	4940	LC1G400
220	380	70	GV6P500●	400	5200	LC1G500
250	430	70	GV6P500●	440	5720	LC1G500

⁽¹⁾ Product type to be completed by replacing the ● with the breaking performance code:

Rated conditional short-circuit (kA)	GV4P/GV4PE/GV4PEM115●			GV5P150●/ 220● GV6P320●/ 500●	
Breaking performance code	B	N	S	F	H
400 V	25	50	100	36	70

45 to 450 kW at 400 V: type 2 coordination (with ComPact NSX/NS circuit breakers)						
Standard power ratings of 3-phase motors 50/60 Hz in category AC-3e			Circuit breaker			Contactor
400 V			Product type ⁽¹⁾	Ir setting ⁽²⁾	Irm ⁽²⁾	Product type
P	Ie	Iq (max)				
kW	A	kA		A	A	
45	80	130	NSX100● + MicroLogic 2.2 M	86	1105	LC1G115
55	97	130	NSX160● + MicroLogic 2.2 M ⁽³⁾	100	1300	LC1G115
75	132	130	NSX160● + MicroLogic 2.2 M ⁽³⁾	140	1820	LC1G150
90	160	130	NSX250● + MicroLogic 2.2 M ⁽³⁾	170	2210	LC1G185
110	195	130	NSX250● + MicroLogic 2.2 M ⁽³⁾	200	2600	LC1G225
110	195	130	NSX400● + MicroLogic 2.3 M ⁽³⁾	200	2600	LC1G265
132	230	130	NSX400● + MicroLogic 2.3 M ⁽³⁾	240	3120	LC1G265
160	280	130	NSX400● + MicroLogic 2.3 M ⁽³⁾	300	3900	LC1G330
200	350	130	NSX630● + MicroLogic 2.3 M ⁽³⁾	380	4940	LC1G400
220	380	130	NSX630● + MicroLogic 2.3 M ⁽³⁾	400	5200	LC1G500
250	430	130	NSX630● + MicroLogic 2.3 M ⁽³⁾	440	5720	LC1G500
300	460	130	NS800● + MicroLogic 5.0	470	6110	LC1G630
335	575	130	NS800● + MicroLogic 5.0	640	8320	LC1G630
355	610	130	NS800● + MicroLogic 5.0	640	8320	LC1G800
400	690	130	NS800● + MicroLogic 5.0	720	9360	LC1G800
450	770	130	NS1000● + MicroLogic 5.0	784	10192	LC1G800

⁽¹⁾ Product type to be completed by replacing the ● with the breaking performance code:

Rated conditional short-circuit (kA)	NSX100●/ NSX160●/ NSX250●/ NSX400●/ NSX630●					NS800●/ NS1000●
Breaking performance code	F	N	H	S	L	L
400 V	36	50	70	100	130	150

⁽²⁾ This setting is a general guidance, Ir and Irm should be adjusted according to motor characteristics and conditions of use.

⁽³⁾ Applicable also with MicroLogic 6.2 E-M and 6.3 E-M trip units.

TeSys Giga series – Device selection

Coordination tables

Coordination for D.O.L. / Reverser motor starters

Thermal magnetic circuit breakers + Contactors

55 to 300 kW at 440 V: type 2 coordination (with TeSys GV4/GV5/GV6 circuit breakers)

Standard power ratings of 3-phase motors 50/60 Hz in category AC-3e			Circuit breaker			Contactor
440 V			Product type ⁽¹⁾	Ir setting ⁽²⁾	Irm ⁽²⁾	Product type
P	Ie	Iq (max)				
kW	A	kA		A	A	
55	88	70	GV4P/GV4PE/GV4PEM115●	93	1209	LC1G115
55	88	65	GV5P150●	90	1170	LC1G115
75	120	65	GV5P150●	130	1690	LC1G150
90	145	65	GV5P150●	150	1950	LC1G150
110	177	65	GV5P220●	185	2405	LC1G185
132	209	65	GV5P220●	210	2730	LC1G225
160	255	65	GV6P320●	260	3380	LC1G265
200	318	65	GV6P320●	320	4160	LC1G330
220	343	65	GV6P500●	350	4550	LC1G400
250	390	65	GV6P500●	400	5200	LC1G400
300	466	65	GV6P500●	470	6580	LC1G500

(1) Product type to be completed by replacing the ● with the breaking performance code:

Rated conditional short-circuit (kA)	GV4P/GV4PE/GV4PEM115●					GV5P150●/ 220●		GV6P320●/ 500●	
Breaking performance code	B	N	S	F	H	F	H	F	H
440 V	20	50	70	35	65	30	65		

55 to 450 kW at 440 V: type 2 coordination (with ComPact NSX/NS circuit breakers)

Standard power ratings of 3-phase motors 50/60 Hz in category AC-3e			Circuit breaker			Contactor
440 V			Product type ⁽¹⁾	Ir setting ⁽²⁾	Irm ⁽²⁾	Product type
P	Ie	Iq (max)				
kW	A	kA		A	A	
55	88	130	NSX100● + MicroLogic 2.2 M	90	1170	LC1G115
75	120	130	NSX160● + MicroLogic 2.2 M ⁽³⁾	130	1690	LC1G150
90	145	130	NSX160● + MicroLogic 2.2 M ⁽³⁾	150	1950	LC1G150
110	177	130	NSX250● + MicroLogic 2.2 M ⁽³⁾	185	2405	LC1G185
132	209	130	NSX250● + MicroLogic 2.2 M ⁽³⁾	210	2730	LC1G225
160	255	130	NSX400● + MicroLogic 2.3 M ⁽³⁾	260	3380	LC1G265
200	318	130	NSX400● + MicroLogic 2.3 M ⁽³⁾	320	4160	LC1G330
220	343	130	NSX630● + MicroLogic 2.3 M ⁽³⁾	350	4550	LC1G400
250	390	130	NSX630● + MicroLogic 2.3 M ⁽³⁾	400	5200	LC1G400
300	466	130	NSX630● + MicroLogic 2.3 M ⁽³⁾	470	6110	LC1G500
335	521	130	NS800● + MicroLogic 5.0	560	7280	LC1G630
355	554	130	NS800● + MicroLogic 5.0	560	7280	LC1G630
400	627	130	NS800● + MicroLogic 5.0	640	8320	LC1G800
450	695	130	NS800● + MicroLogic 5.0	720	9360	LC1G800

(1) Product type to be completed by replacing the ● with the breaking performance code:

Rated conditional short-circuit (kA)	NSX100●/ NSX160●/ NSX250●					NSX400●/ NSX630●				NS800●	
Breaking performance code	F	N	H	S	L	F	N	H	S	L	L
440 V	35	50	65	90	130	30	42	65	90	130	130

(2) This setting is a general guidance, Ir and Irm should be adjusted according to motor characteristics and conditions of use.

(3) Applicable also with MicroLogic 6.2 M and 6.3 M trip units.

TeSys Giga series – Device selection

Coordination tables

Coordination for D.O.L. / Reverser motor starters

Thermal magnetic circuit breakers + Contactors

65 to 295 kW at 500 V: type 2 coordination (with TeSys GV4/GV5/GV6 circuit breakers)

Standard power ratings of 3-phase motors 50/60 Hz in category AC-3e			Circuit breaker			Contactor
500 V			Product type ⁽¹⁾	I _r setting ⁽²⁾	I _{rm} ⁽²⁾	Product type
P	I _e	I _q (max)				
kW	A	kA		A	A	
65	92	30	GV4P/GV4PE/GV4PEM115●	93	1209	LC1G115
65	92	50	GV5P150●	100	1300	LC1G115
90	128	50	GV5P150●	130	1690	LC1G150
110	156	50	GV5P220●	170	2210	LC1G185
132	184	50	GV5P220●	185	2405	LC1G225
160	224	50	GV6P320●	240	3120	LC1G265
200	280	50	GV6P320●	300	3900	LC1G330
250	344	50	GV6P500●	350	4550	LC1G400
295	405	50	GV6P500●	440	5720	LC1G500

(1) Product type to be completed by replacing the ● with the breaking performance code:

Rated conditional short-circuit (kA)	GV4P/GV4PE/GV4PEM115●			GV5P150●/ 220●		GV6P320●/ 500●	
	B	N	S	F	H	F	H
500 V	10	25	30	30	50	25	50

65 to 425 kW at 500 V: type 2 coordination (with ComPacT NSX/NS circuit breakers)

Standard power ratings of 3-phase motors 50/60 Hz in category AC-3e			Circuit breaker			Contactor
500 V			Product type ⁽¹⁾	I _r setting ⁽²⁾	I _{rm} ⁽²⁾	Product type
P	I _e	I _q (max)				
kW	A	kA		A	A	
65	92	70	NSX100● + MicroLogic 2.2 M	95	1235	LC1G115
65	92	70	NSX160● + MicroLogic 2.2 M ⁽³⁾	95	1235	LC1G115
90	128	70	NSX160● + MicroLogic 2.2 M ⁽³⁾	130	1690	LC1G150
110	156	70	NSX250● + MicroLogic 2.2 M ⁽³⁾	170	2210	LC1G185
132	184	70	NSX250● + MicroLogic 2.2 M ⁽³⁾	185	2405	LC1G225
160	224	70	NSX400● + MicroLogic 2.3 M ⁽³⁾	240	3120	LC1G265
200	280	70	NSX400● + MicroLogic 2.3 M ⁽³⁾	300	3900	LC1G330
250	344	70	NSX630● + MicroLogic 2.3 M ⁽³⁾	350	4550	LC1G400
295	405	70	NSX630● + MicroLogic 2.3 M ⁽³⁾	440	5720	LC1G500
375	516	70	NS800● + MicroLogic 5.0	560	7280	LC1G630
425	584	70	NS800● + MicroLogic 5.0	640	8320	LC1G800

(1) Product type to be completed by replacing the ● with the breaking performance code:

Rated conditional short-circuit (kA)	NSX100●					NSX160●/ NSX250●					NSX400●/ NSX630●					NS800●
	F	N	H	S	L	F	N	H	S	L	F	N	H	S	L	L
500 V	25	36	50	65	70	30	36	50	65	70	25	30	50	65	70	100

(2) This setting is a general guidance, I_r and I_{rm} should be adjusted according to motor characteristics and conditions of use.

(3) Applicable also with MicroLogic 6.2 M and 6.3 M trip units.

TeSys Giga series – Device selection

Coordination tables

Coordination for D.O.L. / Reverser motor starters

Thermal magnetic circuit breakers + Contactors

30 to 560 kW at 690 V: type 2 coordination (with ComPacT NSX/NS circuit breakers)						
Standard power ratings of 3-phase motors 50/60 Hz in category AC-3e			Circuit breaker			Contactor
690 V			Product type ⁽¹⁾	Ir Setting ⁽²⁾	Irm ⁽²⁾	Product type
P	Ie	Iq (max)		A	A	
kW	A	kA				
30	32	100	NSX100● + MicroLogic 2.2 M	36	468	LC1G115
37	39	100	NSX100● + MicroLogic 2.2 M	40	520	LC1G115
45	47	100	NSX100● + MicroLogic 2.2 M	50	650	LC1G115
55	57	100	NSX100● + MicroLogic 2.2 M	60	780	LC1G115
75	77	100	NSX100● + MicroLogic 2.2 M	80	1040	LC1G115
90	93	100	NSX250● + MicroLogic 2.2 M ⁽³⁾	95	1235	LC1G150
110	113	100	NSX250● + MicroLogic 2.2 M ⁽³⁾	115	1495	LC1G185
132	134	100	NSX250● + MicroLogic 2.2 M ⁽³⁾	140	1820	LC1G225
160	162	100	NSX250● + MicroLogic 2.2 M ⁽³⁾	170	2210	LC1G225
200	203	100	NSX250● + MicroLogic 2.2 M ⁽³⁾	210	2730	LC1G265
220	223	100	NSX400● + MicroLogic 2.3 M ⁽³⁾	240	3120	LC1G330
250	250	100	NSX400● + MicroLogic 2.3 M ⁽³⁾	260	3380	LC1G400
315	313	100	NSX630● + MicroLogic 2.3 M ⁽³⁾	320	4160	LC1G400
335	335	100	NSX630● + MicroLogic 2.3 M ⁽³⁾	350	4550	LC1G500
355	354	100	NSX630● + MicroLogic 2.3 M ⁽³⁾	380	4940	LC1G500
375	374	100	NSX630● + MicroLogic 2.3 M ⁽³⁾	380	4940	LC1G630
400	400	100	NSX630● + MicroLogic 2.3 M ⁽³⁾	440	5720	LC1G630
450	455	100	NSX630● + MicroLogic 2.3 M ⁽³⁾	470	6110	LC1G630
475	475	100	NSX630● + MicroLogic 2.3 M ⁽³⁾	500	6500	LC1G630
500	493	100	NSX630● + MicroLogic 2.3 M ⁽³⁾	500	6500	LC1G630
560	551	75	NS800● + MicroLogic 5.0	560	7280	LC1G800

⁽¹⁾ Product type to be completed by replacing the ● with the breaking performance code:

Rated conditional short-circuit (kA)	NSX100●/ NSX250●/ NSX400●/ NSX630●		NS800●
Breaking performance code	HB1	HB2	LB
690 V	75	100	75

⁽²⁾ This setting is a general guidance, Ir and Irm should be adjusted according to motor characteristics and conditions of use.

⁽³⁾ Applicable also with MicroLogic 6.2 E-M and 6.3 E-M trip units.

TeSys Giga series – Device selection

Coordination tables

Coordination for D.O.L. / Reverser motor starters

Fuses (NFC, DIN type aM) + Contactors + Overload relay

55 to 335 kW at 400 V: type 2 coordination								
Standard power ratings of 3-phase motors 50/60 Hz in category AC-3e			Switch-disconnector Product type	aM fuses		Contactor Product type	Thermal overload relay	
400 V				Size	Rating		Product type	Product type
P	I _e	I _q (max)						
kW	A	kA			A			A
55	97	80	GS _o L	0	125	LC1G115	LR9G115	97
75	132	80	GS _o L	0	160	LC1G150	LR9G225	132
90	160	80	GS _o N	1	200	LC1G185	LR9G225	160
110	195	80	GS _o N	1	250	LC1G225	LR9G225	195
132	230	80	GS _o QQ	2	315	LC1G265	LR9G500	230
160	280	80	GS _o QQ	2	400	LC1G330	LR9G500	280
200	350	80	GS2S	3	500	LC1G400	LR9G500	350
220	380	80	GS2S	3	500	LC1G500	LR9G500	380
250	430	80	GS2S	3	500	LC1G500	LR9G500	430
315	540	80	GS2S	3	630	LC1G630 ⁽²⁾	LR9G630	540
335	575	80	GS2V	4	800	LC1G630 ⁽²⁾	LR9G630	575

75 to 400 kW at 440 V: type 2 coordination								
Standard power ratings of 3-phase motors 50/60 Hz in category AC-3e			Switch-disconnector Product type	aM fuses		Contactor Product type	Thermal overload relay	
440 V				Size	Rating		Product type	Product type
P	I _e	I _q (max)						
kW	A	kA			A			A
75	115	80	GS _o L	0	125	LC1G115	LR9G115	115
90	145	80	GS _o L	0	160	LC1G150	LR9G225	145
110	177	80	GS _o N	1	200	LC1G185	LR9G225	177
132	209	80	GS _o N	1	250	LC1G225	LR9G225	209
160	255	80	GS _o QQ	2	315	LC1G265	LR9G500	255
200	318	80	GS _o QQ	2	400	LC1G330	LR9G500	318
220	343	80	GS2S	3	500	LC1G400	LR9G500	343
250	390	80	GS2S	3	500	LC1G500	LR9G500	390
315	505	80	GS2S	3	500	LC1G500	LR9G500	505
355	554	80	GS2S	3	630	LC1G630 ⁽²⁾	LR9G630	554
400	627	80	GS2V	4	800	LC1G630 ⁽²⁾	LR9G630	627

65 to 375 kW at 500 V: type 2 coordination								
Standard power ratings of 3-phase motors 50/60 Hz in category AC-3e			Switch-disconnector Product type	aM fuses		Contactor Product type	Thermal overload relay	
500 V				Size	Rating		Product type	Product type
P	I _e	I _q (max)						
kW	A	kA			A			A
65	92	80	GS _o L	0	125	LC1G115	LR9G115	92
90	128	80	GS _o L	0	160	LC1G150	LR9G225	128
110	156	80	GS _o N	1	200	LC1G185	LR9G225	156
132	184	80	GS _o N	1	250	LC1G225	LR9G225	184
160	224	80	GS _o QQ	2	315	LC1G265	LR9G500	224
200	280	80	GS _o QQ	2	400	LC1G330	LR9G500	280
250	344	80	GS2S	3	500	LC1G400	LR9G500	344
295	405	80	GS2S	3	500	LC1G500	LR9G500	405
375	516	80	GS2S	3	630	LC1G630	LR9G630	516

⁽¹⁾ This setting is a general guidance, Ir should be adjusted according to motor characteristics and conditions of use.

⁽²⁾ Available mid-2022.

TeSys Giga series – Device selection

Coordination tables

Coordination for D.O.L. / Reverser motor starters

Fuses (NFC, DIN type aM) + Contactors + Overload relay

55 to 500 kW at 690 V: type 2 coordination								
Standard power ratings of 3-phase motors 50/60 Hz in category AC-3e			Switch- disconnecter	aM fuses		Contactor	Thermal overload relay	
690 V			Product type	Size	Rating	Product type	Product type	Ir setting ⁽¹⁾
P	I _e	I _q (max)						
kW	A	kA			A			A
55	57	80	GS●J	22 x 58	80	LC1G115	LR9G225	57
75	77	80	GS●KK	0	100	LC1G115	LR9G225	77
90	93	80	GS●KK	0	125	LC1G150	LR9G225	93
110	113	80	GS●KK	0	160	LC1G185	LR9G225	113
132	134	80	GS●L	0	160	LC1G225	LR9G225	134
160	162	80	GS●N	1	200	LC1G225	LR9G225	162
200	203	80	GS●N	1	250	LC1G265	LR9G500	203
220	223	80	GS●QQ	2	250	LC1G330	LR9G500	223
250	250	80	GS●QQ	2	315	LC1G330	LR9G500	250
315	313	80	GS●QQ	2	400	LC1G400	LR9G500	313
355	354	80	GS●QQ	3	500	LC1G500	LR9G500	354
500	493	80	GS●S	3	630	LC1G630	LR9G630	493

Fuses (NFC, DIN type aM) + Contactors + TeSys T + current transformers

90 to 355 kW at 400 V: type 2 coordination									
Standard power ratings of 3-phase motors 50/60 Hz in category AC-3e			Switch- disconnecter	aM fuses		Contactor	TeSys T Motor management controller		Current transformers
400 V			Product type	Size	Rating	Product type	Product type ⁽²⁾	Ir setting ⁽¹⁾	Reference
P	I _e	I _q (max)							
kW	A	kA			A			A	
90	160	80	GS●●N	1	200	LC1G185	LTMR08●●●	160	LUTC2001
110	195	80	GS●●N	1	250	LC1G225	LTMR08●●●	195	LUTC4001
132	230	80	GS●●QQ	2	315	LC1G265	LTMR08●●●	230	LUTC4001
160	280	80	GS●●QQ	2	400	LC1G330	LTMR08●●●	280	LUTC4001
200	350	80	GS2S	3	500	LC1G400	LTMR08●●●	350	LUTC8001
250	430	80	GS2S	3	500	LC1G500	LTMR08●●●	430	LUTC8001
315	540	80	GS2S	3	630	LC1G630	LTMR08●●●	540	LUTC8001
355	610	80	GS2V	4	800	LC1G630	LTMR08●●●	610	LUTC8001

(1) This setting is a general guidance, Ir should be adjusted according to motor characteristics and conditions of use.

(2) Please refer to TeSys Catalogue to select the complete reference for TeSys T motor management controller.

TeSys Giga series – Device selection

Coordination tables

Coordination for D.O.L. / Reverser motor starters

Magnetic circuit breaker + Contactor + Overload relay

45 to 335 kW at 400 V: type 2 coordination (with TeSys GV4 or ComPact NSX circuit breakers and LR9G overload relays)

Standard power ratings of 3-phase motors 50/60 Hz in category AC-3e			Circuit breaker		Contactor	Thermal overload relay	
400 V			Product type ⁽¹⁾	I _{rm} ⁽²⁾	Product type	Product type	I _r setting ⁽²⁾
P	I _e	I _q (max)					
kW	A	kA		A			A
45	80	100	GV4L/GV4LE115●	1265	LC1G115	LR9G115	80
55	97	100	GV4L/GV4LE115●	1100	LC1G115	LR9G225	80
45	80	130	NSX100● + MA	1265	LC1G115	LR9G115	97
55	97	130	NSX160● + MA	1500	LC1G115	LR9G225	97
75	132	130	NSX160● + MA	1800	LC1G150	LR9G225	132
90	160	130	NSX250● + MA	2640	LC1G185	LR9G225	160
110	195	130	NSX250● + MA	2640	LC1G225	LR9G225	195
110	195	130	NSX400● + MicroLogic 1.3 M	3520	LC1G265	LR9G500	195
132	230	130	NSX400● + MicroLogic 1.3 M	3520	LC1G265	LR9G500	230
160	280	130	NSX400● + MicroLogic 1.3 M	3840	LC1G330	LR9G500	280
200	350	130	NSX630● + MicroLogic 1.3 M	5500	LC1G400	LR9G500	350
220	380	130	NSX630● + MicroLogic 1.3 M	5500	LC1G500	LR9G500	380
250	430	130	NSX630● + MicroLogic 1.3 M	6000	LC1G500	LR9G500	430
300	460	130	NS800● + MicroLogic 5.0 LR OFF	8800	LC1G630	LR9G630	460
335	575	130	NS800● + MicroLogic 5.0 LR OFF	9600	LC1G630	LR9G630	575

(1) Product type to be completed by replacing the ● with the breaking performance code:

Rated conditional short-circuit (kA)	GV4L115●/ GV4LE115●			NSX100●/ NSX160●/ NSX250●/ NSX400●/ NSX630●					NS800●
	B	N	S	F	N	H	S	L	L
400 V	25	50	100	36	50	70	100	130	150

55 to 355 kW at 440 V: type 2 coordination (with TeSys GV4 or ComPact NSX/NS circuit breakers and LR9G overload relays)

Standard power ratings of 3-phase motors 50/60 Hz in category AC-3e			Circuit breaker		Contactor	Thermal overload relay	
440 V			Product type ⁽¹⁾	I _{rm} ⁽²⁾	Product type	Product type	I _r setting ⁽²⁾
P	I _e	I _q (max)					
kW	A	kA		A			A
55	88	70	GV4L/GV4LE115●	1150	LC1G115	LR9G115	88
55	88	130	NSX100● + MA	1500	LC1G115	LR9G115	88
75	120	130	NSX160● + MA	1800	LC1G150	LR9G225	120
90	145	130	NSX160● + MA	2640	LC1G150	LR9G225	145
110	177	130	NSX250● + MA	2640	LC1G185	LR9G225	177
132	209	130	NSX250● + MA	2860	LC1G225	LR9G225	209
160	255	130	NSX400● + MicroLogic 1.3 M	3520	LC1G265	LR9G500	255
200	318	130	NSX400● + MicroLogic 1.3 M	4160	LC1G330	LR9G500	318
220	343	130	NSX630● + MicroLogic 1.3 M	5500	LC1G400	LR9G500	343
250	390	130	NSX630● + MicroLogic 1.3 M	5500	LC1G400	LR9G500	390
300	466	130	NSX630● + MicroLogic 1.3 M	6500	LC1G500	LR9G500	466
335	521	130	NS800● + MicroLogic 5.0 LR OFF	8800	LC1G630	LR9G630	521
355	554	130	NS800● + MicroLogic 5.0 LR OFF	9600	LC1G630	LR9G630	554

(1) Product type to be completed by replacing the ● with the breaking performance code:

Rated conditional short-circuit (kA)	GV4L115●/ GV4LE115●			NSX100●/ NSX160●/ NSX250●					NSX400●/ NSX630●					NS800●
	B	N	S	F	N	H	S	L	F	N	H	S	L	L
440 V	20	50	70	35	50	65	100	130	30	42	65	100	130	150

(2) This setting is a general guidance, I_r and I_{rm} should be adjusted according to motor characteristics and conditions of use.

TeSys Giga series - Device selection

Coordination tables

Coordination for D.O.L. / Reverser motor starters

Magnetic circuit breaker + Contactor + Overload relay

65 to 425 kW at 500 V: type 2 coordination (with TeSys GV4 or ComPacT NSX/NS circuit breakers and LR9G overload relays)							
Standard power ratings of 3-phase motors 50/60 Hz in category AC-3e			Circuit breaker	Contactor	Thermal overload relay		
500 V			Product type ⁽¹⁾	I _{rm} ⁽²⁾	Product type	Product type	I _r setting ⁽²⁾
P	I _e	I _q (max)					
kW	A	kA					
65	92	30	GV4L/GV4LE115●	1380	LC1G115	LR9G115	92
65	92	70	NSX100● + MA100	1300	LC1G115	LR9G115	92
90	128	70	NSX160● + MA150	1950	LC1G150	LR9G225	128
110	156	70	NSX250● + MA220	2200	LC1G185	LR9G225	156
132	184	70	NSX400● + MicroLogic 1.3 M	2560	LC1G225	LR9G225	184
160	224	70	NSX400● + MicroLogic 1.3 M	3200	LC1G265	LR9G500	224
200	280	70	NSX400● + MicroLogic 1.3 M	3840	LC1G330	LR9G500	280
250	344	70	NSX630● + MicroLogic 1.3 M	5500	LC1G400	LR9G500	344
295	405	70	NSX630● + MicroLogic 1.3 M	6500	LC1G500	LR9G500	405
375	516	70	NS800● + MicroLogic 5.0 LR OFF	8800	LC1G630	LR9G630	516
425	584	70	NS800● + MicroLogic 5.0 LR OFF	9600	LC1G800	LR9G630	584

(1) Product type to be completed by replacing the ● with the breaking performance code:

Rated conditional short-circuit (kA)	GV4L115●/GV4LE115●			NSX100●					NSX160●/NSX250●					NSX400●/NSX630●					NS800●
	B	N	S	F	N	H	S	L	F	N	H	S	L	F	N	H	S	L	L
500 V	10	25	30	25	36	50	65	70	30	36	50	65	70	25	30	50	65	70	100

30 to 500 kW at 690 V: type 2 coordination (with ComPacT NSX/NS circuit breakers and LR9G overload relays)							
Standard power ratings of 3-phase motors 50/60 Hz in category AC-3e			Circuit breaker	Contactor	Thermal overload relay		
690 V			Product type ⁽¹⁾	I _{rm} ⁽²⁾	Product type	Product type	I _r setting ⁽²⁾
P	I _e	I _q (max)					
kW	A	kA					
30	32	100	NSX100● + MA	550	LC1G115	LR9G115	32
37	39	100	NSX100● + MA	550	LC1G115	LR9G115	39
45	47	100	NSX100● + MA	650	LC1G115	LR9G115	47
55	57	100	NSX100● + MA	1100	LC1G150	LR9G115	57
75	77	100	NSX100● + MA	1100	LC1G185	LR9G225	77
90	93	100	NSX250● + MA	1650	LC1G225	LR9G225	93
110	113	100	NSX250● + MA	1650	LC1G225	LR9G225	113
132	134	100	NSX250● + MA	1800	LC1G265	LR9G500	134
160	162	100	NSX250● + MA	2420	LC1G330	LR9G500	162
200	203	100	NSX250● + MA	2640	LC1G400	LR9G500	203
220	223	100	NSX400● + MicroLogic 1.3 M	3520	LC1G400	LR9G500	223
250	250	100	NSX400● + MicroLogic 1.3 M	3520	LC1G500	LR9G500	250
315	313	100	NSX630● + MicroLogic 1.3 M	5500	LC1G500	LR9G500	313
335	335	100	NSX630● + MicroLogic 1.3 M	5500	LC1G630	LR9G630	335
355	354	100	NSX630● + MicroLogic 1.3 M	5500	LC1G630	LR9G630	354
375	374	100	NSX630● + MicroLogic 1.3 M	5500	LC1G630	LR9G630	374
400	400	100	NSX630● + MicroLogic 1.3 M	5500	LC1G630	LR9G630	400
450	455	100	NSX630● + MicroLogic 1.3 M	6000	LC1G630	LR9G630	455
475	475	100	NSX630● + MicroLogic 1.3 M	6500	LC1G630	LR9G630	475
500	493	100	NSX630● + MicroLogic 1.3 M	6500	LC1G630	LR9G630	493

(1) Product type to be completed by replacing the ● with the breaking performance code:

Rated conditional short-circuit (kA)	NSX100●/NSX250●/NSX400●/NSX630●	
Breaking performance code	HB1	HB2
690 V	75	100

(2) This setting is a general guidance, I_r and I_{rm} should be adjusted according to motor characteristics and conditions of use.

TeSys Giga series - Device selection

Coordination tables

Coordination for D.O.L. / Reverser motor starters

Magnetic circuit breakers + Contactor + TeSys T + current transformers

90 to 250 kW at 400 V: type 2 coordination								
Standard power ratings of 3-phase motors 50/60 Hz in category AC-3e			Circuit breaker		Contactor	TeSys T Motor management controller		Current transformers
400 V			Product type ⁽¹⁾	I _{rm} ⁽²⁾	Product type	Product type ⁽³⁾	I _r setting ⁽²⁾	Reference
P	I _e	I _q (max)		A			A	
kW	A	kA						
90	160	130	NSX250● + MA	2200	LC1G185	LTMR08●●	160	LUTC2001
110	195	130	NSX250● + MA	2640	LC1G225	LTMR08●●	195	LUTC2001
132	230	130	NSX400● + MicroLogic 1.3 M	3200	LC1G265	LTMR08●●	230	LUTC4001
150	280	130	NSX400● + MicroLogic 1.3 M	3840	LC1G330	LTMR08●●	280	LUTC4001
200	350	130	NSX630● + MicroLogic 1.3 M	5000	LC1G400	LTMR08●●	350	LUTC4001
220	388	130	NSX630● + MicroLogic 1.3 M	5500	LC1G500	LTMR08●●	388	LUTC4001
250	430	130	NSX630● + MicroLogic 1.3 M	6000	LC1G500	LTMR08●●	430	LUTC8001
300	460	130	NS800L + MicroLogic 5.0 LR OFF	8800	LC1G630	LTMR08●●	460	LUTC8001
335	575	130	NS800L + MicroLogic 5.0 LR OFF	9600	LC1G630	LTMR08●●	575	LUTC8001

(1) Product type to be completed by replacing the ● with the breaking performance code:

Rated conditional short-circuit (kA)	NSX250●/ NSX400●/ NSX630●					NS800●
Breaking performance code	F	N	H	S	L	L
400 V	36	50	70	100	130	150

110 to 400 kW at 690 V: type 2 coordination									
Standard power ratings of 3-phase motors 50/60 Hz in category AC-3e			Switch-disconnector	aM fuses		Contactor	TeSys T Motor management controller	Current transformers	
690 V			Product type	Size	Rating	Product type	Product type ⁽³⁾	I _r setting ⁽²⁾	Reference
P	I _e	I _q (max)			A			A	
kW	A	kA							
110	113	80	GS●●KK	0	125	LC1G185	LTMR08●●●	113	LUTC2001
132	134	80	GS●●L	0	160	LC1G265	LTMR08●●●	134	LUTC2001
160	162	80	GS●●N	1	160	LC1G265	LTMR08●●●	162	LUTC2001
200	203	80	GS●●N	1	200	LC1G330	LTMR08●●●	203	LUTC2001
220	224	80	GS●●QQ	2	250	LC1G400	LTMR08●●●	224	LUTC4001
250	250	80	GS●●QQ	2	250	LC1G400	LTMR08●●●	250	LUTC4001
290	292	80	GS●●QQ	2	315	LC1G500	LTMR08●●●	292	LUTC4001
315	313	80	GS●●QQ	2	400	LC1G500	LTMR08●●●	313	LUTC4001
355	354	80	GS2S	3	500	LC1G630	LTMR08●●●	354	LUTC4001
400	400	80	GS2S	3	630	LC1G630	LTMR08●●●	400	LUTC8001

(2) This setting is a general guidance, I_r and I_{rm} should be adjusted according to motor characteristics and conditions of use.

(3) Please refer to TeSys Catalogue to select the complete reference for TeSys T motor management controller.

TeSys Giga series – Device selection

Coordination tables

Optimized solutions for Star-Delta motor starters

Thermal magnetic circuit breakers + Contactors

Contactors: **Maximum operating rate:** 30 starts/hour - **Maximum starting time:** 30 seconds.

The coordination table is for normal starting conditions (Class 10e/ 20e). For other heavy starting applications with long start times, please contact technical support.

RE17RMMWS timer to be used for Star-Delta starter application.

90 to 250 kW at 400 V: type 2 coordination (with TeSys GV5/GV6 circuit breakers)							
Standard power ratings of 3-phase motors 50/60 Hz in category AC-3			Circuit breaker			Contactor Line (KM2) / Delta (KM3) ⁽³⁾	Contactor Star (KM1) ⁽³⁾
400 V			Product type ⁽¹⁾	I _r setting ⁽²⁾	I _{rm} ⁽²⁾	Product type	
P	I _e	I _q (max)					
kW	A	kA		A	A		
90	160	70	GV5P220●	170	1360	LC1G115	LC1D65
110	195	70	GV5P220●	200	1600	LC1G150	LC1D80
110	195	70	GV6P320●	200	1600	LC1G150	LC1D80
132	230	70	GV6P320●	240	1920	LC1G150	LC1D95
160	280	70	GV6P320●	300	2400	LC1G185	LC1G115
200	350	70	GV6P500●	380	3040	LC1G225	LC1G115
220	380	70	GV6P500●	400	3200	LC1G265	LC1G150
250	430	70	GV6P500●	440	3520	LC1G265	LC1G150

⁽¹⁾ Product type to be completed by replacing the ● with the breaking performance code:

Rated conditional short-circuit (kA)	GV5P220● GV6P320●/GV6P500●		
Breaking performance code	F	H	
400 V	36	70	

90 to 450 kW at 400 V: type 2 coordination (with ComPact NSX/NS circuit breakers)							
Standard power ratings of 3-phase motors 50/60 Hz in category AC-3			Circuit breaker			Contactor Line (KM2) / Delta (KM3) ⁽³⁾	Contactor Star (KM1) ⁽³⁾
400 V			Product type ⁽¹⁾	I _r setting ⁽²⁾	I _{rm} ⁽²⁾	Product type	
P	I _e	I _q (max)					
kW	A	kA		A	A		
90	160	130	NSX250● + MicroLogic 2.2 M	170	1360	LC1G115	LC1D65
110	195	130	NSX250● + MicroLogic 2.2 M	200	1600	LC1G150	LC1D80
110	195	130	NSX400● + MicroLogic 2.3 M	200	1600	LC1G150	LC1D80
132	230	130	NSX400● + MicroLogic 2.3 M	240	1920	LC1G150	LC1D95
160	280	130	NSX400● + MicroLogic 2.3 M	300	2400	LC1G185	LC1G115
200	350	130	NSX630● + MicroLogic 2.3 M	380	3040	LC1G225	LC1G115
220	380	130	NSX630● + MicroLogic 2.3 M	400	3200	LC1G265	LC1G150
250	430	130	NSX630● + MicroLogic 2.3 M	440	3520	LC1G265	LC1G150
300	460	130	NS800● + MicroLogic 5.0	480	3840	LC1G330	LC1G185
335	575	130	NS800● + MicroLogic 5.0	640	5120	LC1G400	LC1G225
355	610	130	NS800● + MicroLogic 5.0	640	5120	LC1G400	LC1G225
400	690	130	NS800● + MicroLogic 5.0	720	5760	LC1G500	LC1G265
450	770	130	NS1000● + MicroLogic 5.0	784	6272	LC1G500	LC1G330

⁽¹⁾ Product type to be completed by replacing the ● with the breaking performance code:

Rated conditional short-circuit (kA)	NSX250● / NSX400● / NSX630●					NS800● / NS1000●
Breaking performance code	F	N	H	S	L	L
400 V	36	50	70	100	150	150

⁽²⁾ This setting is a general guidance, I_r and I_{rm} should be adjusted according to motor characteristics and conditions of use.

⁽³⁾ Refer to diagram in page 65.

TeSys Giga series – Device selection

Coordination tables

Optimized solutions for Star-Delta motor starters

Thermal magnetic circuit breakers + Contactors

Contactors: **Maximum operating rate:** 30 starts/hour - **Maximum starting time:** 30 seconds.

The coordination table is for normal starting conditions (Class 10e/ 20e). For other heavy starting applications with long start times, please contact technical support.

RE17RMMWS timer to be used for Star-Delta starter application.

110 to 300 kW at 440 V: type 2 coordination (with TeSys GV5/GV6 circuit breakers)							
Standard power ratings of 3-phase motors 50/60 Hz in category AC-3			Circuit breaker			Contactor Line (KM2) / Delta (KM3) ⁽³⁾	Contactor Star (KM1) ⁽³⁾
440 V			Product type ⁽¹⁾	Ir setting ⁽²⁾	Irm ⁽²⁾	Product type	
P	Ie	Iq (max)		A	A		
kW	A	kA					
110	177	65	GV5P220●	185	1480	LC1G115	LC1D65
132	209	65	GV5P220●	210	1680	LC1G150	LC1D80
160	255	65	GV6P320●	260	2080	LC1G185	LC1G115
200	318	65	GV6P320●	320	2560	LC1G225	LC1G115
220	343	65	GV6P500●	350	2800	LC1G225	LC1G150
250	390	65	GV6P500●	400	3200	LC1G265	LC1G150
300	466	65	GV6P500●	470	3760	LC1G330	LC1G185

(1) Product type to be completed by replacing the ● with the breaking performance code:

Rated conditional short-circuit (kA)	GV5P220●			GV6P320●/GV6P500●		
Breaking performance code	F	H		F	H	
440 V	35	65		30	65	

110 to 450 kW at 440 V: type 2 coordination (with ComPacT NSX/NS circuit breakers)							
Standard power ratings of 3-phase motors 50/60 Hz in category AC-3			Circuit breaker			Contactor Line (KM2) / Delta (KM3) ⁽³⁾	Contactor Star (KM1) ⁽³⁾
440 V			Product type ⁽¹⁾	Ir setting ⁽²⁾	Irm ⁽²⁾	Product type	
P	Ie	Iq (max)		A	A		
kW	A	kA					
110	177	130	NSX250● + MicroLogic 2.2 M	185	1480	LC1G115	LC1D65
132	209	130	NSX250● + MicroLogic 2.2 M	210	1680	LC1G150	LC1D80
160	255	130	NSX400● + MicroLogic 2.3 M	260	2080	LC1G185	LC1G115
200	318	130	NSX400● + MicroLogic 2.3 M	320	2560	LC1G225	LC1G115
220	343	130	NSX630● + MicroLogic 2.3 M	350	2800	LC1G225	LC1G150
250	390	130	NSX630● + MicroLogic 2.3 M	400	3200	LC1G265	LC1G150
300	466	130	NSX630● + MicroLogic 2.3 M	470	3760	LC1G330	LC1G185
335	521	130	NS800● + MicroLogic 5.0	560	4480	LC1G330	LC1G185
355	554	130	NS800● + MicroLogic 5.0	560	4480	LC1G400	LC1G225
400	627	130	NS800● + MicroLogic 5.0	640	5120	LC1G400	LC1G225
450	695	130	NS800● + MicroLogic 5.0	720	5760	LC1G500	LC1G265

(1) Product type to be completed by replacing the ● with the breaking performance code:

Rated conditional short-circuit (kA)	NSX250●					NSX400●/ NSX630●					NS800●
Breaking performance code	F	N	H	S	L	F	N	H	S	L	L
440 V	35	50	65	100	130	30	42	65	100	130	130

(2) This setting is a general guidance. Ir and Irm should be adjusted according to motor characteristics and conditions of use.

(3) Refer to diagram in page 65.

TeSys Giga series – Device selection

Coordination tables

Optimized solutions for Star-Delta motor starters

Thermal magnetic circuit breakers + Contactors

Contactors: **Maximum operating rate:** 30 starts/hour - **Maximum starting time:** 30 seconds.

The coordination table is for normal starting conditions (Class 10e/ 20e). For other heavy starting applications with long start times, please contact technical support.

RE17RMMWS timer to be used for Star-Delta starter application.

132 to 295 kW at 500 V: type 2 coordination (with TeSys GV5/GV6 circuit breakers)							
Standard power ratings of 3-phase motors 50/60 Hz in category AC-3			Circuit breaker			Contactor Line (KM2) / Delta (KM3) ⁽³⁾	Contactor Star (KM1) ⁽³⁾
500 V			Product type ⁽¹⁾	Ir setting ⁽²⁾	Irm ⁽²⁾	Product type	
P	Ie	Iq (max)		A	A		
kW	A	kA					
132	184	50	GV5P220●	185	1480	LC1G115	LC1D65
160	224	50	GV6P320●	240	1920	LC1G150	LC1D80
200	280	50	GV6P320●	300	2400	LC1G185	LC1G115
250	344	50	GV6P500●	350	2800	LC1G225	LC1G115
295	405	50	GV6P500●	440	3520	LC1G265	LC1G150

⁽¹⁾ Product type to be completed by replacing the ● with the breaking performance code:

Rated conditional short-circuit (kA)	GV5P220●		GV6P320●/ 500●	
Breaking performance code	F	H	F	H
500 V	30	50	25	50

132 to 425 kW at 500 V: type 2 coordination (with ComPact NSX/NS circuit breakers)							
Standard power ratings of 3-phase motors 50/60 Hz in category AC-3			Circuit breaker			Contactor Line (KM2) / Delta (KM3) ⁽³⁾	Contactor Star (KM1) ⁽³⁾
500 V			Product type ⁽¹⁾	Ir setting ⁽²⁾	Irm ⁽²⁾	Product type	
P	Ie	Iq (max)		A	A		
kW	A	kA					
132	184	70	NSX250● + MicroLogic 2.2 M ⁽⁴⁾	185	1480	LC1G115	LC1D65
160	224	70	NSX400● + MicroLogic 2.3 M ⁽⁴⁾	240	1920	LC1G150	LC1D80
200	280	70	NSX400● + MicroLogic 2.3 M ⁽⁴⁾	300	2400	LC1G185	LC1G115
250	344	70	NSX630● + MicroLogic 2.3 M ⁽⁴⁾	350	2800	LC1G225	LC1G115
295	405	70	NSX630● + MicroLogic 2.3 M ⁽⁴⁾	440	3520	LC1G265	LC1G150
375	516	70	NS800● + MicroLogic 5.0	560	4480	LC1G330	LC1G185
425	584	70	NS800● + MicroLogic 5.0	640	5120	LC1G400	LC1G225

⁽¹⁾ Product type to be completed by replacing the ● with the breaking performance code:

Rated conditional short-circuit (kA)	NSX250●					NSX400●/ NSX630●					NS800●
Breaking performance code	F	N	H	S	L	F	N	H	S	L	L
500 V	30	36	50	65	70	25	30	50	65	70	100

⁽²⁾ This setting is a general guidance, Ir and Irm should be adjusted according to motor characteristics and conditions of use.

⁽³⁾ Refer to diagram in page 65.

⁽⁴⁾ Applicable also with MicroLogic 6.2 M and 6.3 M trip units.

TeSys Giga series – Device selection

Coordination tables

Optimized solutions for Star-Delta motor starters

Fuses (DIN type aM) + Contactors + Overload relay

Contactor: **Maximum operating rate:** 30 starts/hour - **Maximum starting time:** 30 seconds.

The coordination table is for normal starting conditions (Class 10e/ 20e). For other heavy starting applications with long start times, please contact technical support.

RE17RMMWS timer to be used for Star-Delta starter application.

90 to 335 kW at 400 V: type 2 coordination									
Standard power ratings of 3-phase motors 50/60 Hz in category AC-3			Switch-disconnector	aM fuses		Contactor Line (KM2) / Delta (KM3) ⁽¹⁾	Contactor Star (KM1) ⁽¹⁾	Thermal overload relay	
400 V			Product type	Size	Rating	Product type		Product type	Ir setting ⁽²⁾
P	I _e	I _q (max)							
kW	A	kA			A				A
90	160	80	GS●N	1	200	LC1G115	LC1D65	LR9G115	92
110	195	80	GS●N	1	250	LC1G150	LC1D80	LR9G225	113
132	230	80	GS●QQ	2	315	LC1G185	LC1G115	LR9G225	133
160	280	80	GS●QQ	2	400	LC1G225	LC1G115	LR9G225	162
200	350	80	GS2●S	3	500	LC1G265	LC1G115	LR9G225	202
220	380	80	GS2●S	3	500	LC1G330	LC1G150	LR9G500	219
250	430	80	GS2●S	3	500	LC1G400	LC1G150	LR9G500	248
315	540	80	GS2●S	3	630	LC1G500	LC1G225	LR9G500	312
335	575	80	GS2●V	4	800	LC1G500	LC1G225	LR9G500	332

110 to 400 kW at 440 V: type 2 coordination									
Standard power ratings of 3-phase motors 50/60 Hz in category AC-3			Switch-disconnector	aM fuses		Contactor Line (KM2) / Delta (KM3) ⁽¹⁾	Contactor Star (KM1) ⁽¹⁾	Thermal overload relay	
440 V			Product type	Size	Rating	Product type		Product type	Ir setting ⁽²⁾
P	I _e	I _q max							
kW	A	kA			A				A
110	177	80	GS●N	1	200	LC1G115	LC1D65	LR9G115	102
132	209	80	GS●N	1	250	LC1G150	LC1D80	LR9G225	121
160	255	80	GS●QQ	2	315	LC1G150	LC1G115	LR9G225	147
200	318	80	GS●QQ	2	400	LC1G185	LC1G115	LR9G225	184
220	343	80	GS2●S	3	500	LC1G225	LC1G115	LR9G225	198
250	390	80	GS2●S	3	500	LC1G265	LC1G150	LR9G500	225
315	505	80	GS2●S	3	500	LC1G265	LC1G150	LR9G500	292
355	554	80	GS2●S	3	630	LC1G330	LC1G225	LR9G500	320
400	627	80	GS2●V	4	800	LC1G400	LC1G225	LR9G500	362

90 to 315 kW at 500 V: type 2 coordination									
Standard power ratings of 3-phase motors 50/60 Hz in category AC-3			Switch-disconnector	aM fuses		Contactor Line (KM2) / Delta (KM3) ⁽¹⁾	Contactor Star (KM1) ⁽¹⁾	Thermal overload relay	
500 V			Product type	Size	Rating	Product type		Product type	Ir setting ⁽²⁾
P	I _e	I _q max							
kW	A	kA			A				A
90	156	80	GS●N	1	200	LC1G115	LC1D65	LR9G115	90
110	184	80	GS●N	1	250	LC1G150	LC1D80	LR9G115	106
132	224	80	GS●QQ	2	315	LC1G150	LC1G115	LR9G225	129
160	280	80	GS●QQ	2	400	LC1G185	LC1G115	LR9G225	162
200	344	80	GS2●S	3	500	LC1G225	LC1G115	LR9G225	199
220	405	80	GS2●S	3	500	LC1G265	LC1G150	LR9G500	234
250	405	80	GS2●S	3	500	LC1G265	LC1G150	LR9G500	234
315	516	80	GS2●S	3	630	LC1G330	LC1G225	LR9G630	298

(1) Refer to diagram in page 65.

(2) This setting is a general guidance, Ir should be adjusted according to motor characteristics and conditions of use.

TeSys Giga series – Device selection

Coordination tables

Optimized solutions for Star-Delta motor starters

Magnetic circuit breaker + Contactors + Overload relay

Contactors: **Maximum operating rate:** 30 starts/hour - **Maximum starting time:** 30 seconds.

The coordination table is for normal starting conditions (Class 10e/ 20e). For other heavy starting applications with long start times, please contact technical support.

RE17RMMWS timer to be used for Star-Delta starter application.

90 to 450 kW at 400 V: type 2 coordination (with ComPacT NSX/NS circuit breakers and LR9G overload relays)

Standard power ratings of 3-phase motors 50/60 Hz in category AC-3			Circuit breaker	Contactor Line (KM2) / Delta (KM3) ⁽³⁾	Contactor Star (KM1) ⁽³⁾	Thermal overload relay		
400 V			Product type ⁽¹⁾	I _{rm} ⁽²⁾	Product type	Product type	I _r setting ⁽²⁾	
P	I _e	I _q (max)		A			A	
kW	A	kA						
90	160	130	NSX250● + MA	1980	LC1G115	LC1D65	LR9G115	92
110	195	130	NSX250● + MA	1980	LC1G150	LC1D80	LR9G225	113
110	195	130	NSX400● + MicroLogic 1.3 M	1920	LC1G150	LC1D80	LR9G225	113
132	230	130	NSX400● + MicroLogic 1.3 M	1920	LC1G150	LC1D80	LR9G225	133
160	280	130	NSX400● + MicroLogic 1.3 M	2560	LC1G185	LC1G115	LR9G225	162
200	350	130	NSX630● + MicroLogic 1.3 M	3000	LC1G225	LC1G150	LR9G225	202
220	380	130	NSX630● + MicroLogic 1.3 M	3500	LC1G265	LC1G150	LR9G500	219
250	430	130	NSX630● + MicroLogic 1.3 M	3500	LC1G265	LC1G150	LR9G500	248
300	460	130	NS800● + MicroLogic 5.0 LR OFF	4000	LC1G330	LC1G185	LR9G500	266
335	575	130	NS800● + MicroLogic 5.0 LR OFF	4800	LC1G400	LC1G225	LR9G500	332
355	610	130	NS800● + MicroLogic 5.0 LR OFF	5600	LC1G400	LC1G225	LR9G500	352
400	627	130	NS800● + MicroLogic 5.0 LR OFF	5600	LC1G400	LC1G225	LR9G500	362
450	695	130	NS800● + MicroLogic 5.0 LR OFF	6400	LC1G500	LC1G265	LR9G500	401

⁽¹⁾ Product type to be completed by replacing the ● with the breaking performance code:

Rated conditional short-circuit (kA)	NSX250●/ NSX400●/ NSX630●					NS800●
Breaking performance code	F	N	H	S	L	L
400 V	36	50	70	100	130	150

110 to 355 kW at 440 V: type 2 coordination (with ComPacT NSX/NS circuit breakers and LR9G overload relays)

Standard power ratings of 3-phase motors 50/60 Hz in category AC-3			Circuit breaker	Contactor Line (KM2) / Delta (KM3) ⁽³⁾	Contactor Star (KM1) ⁽³⁾	Thermal overload relay		
440 V			Product type ⁽¹⁾	I _{rm} ⁽²⁾	Product type	Product type	I _r setting ⁽²⁾	
P	I _e	I _q (max)		A			A	
kW	A	kA						
110	177	130	NSX250● + MA	1980	LC1G115	LC1D65	LR9G115	102
132	209	130	NSX250● + MA	1980	LC1G150	LC1D80	LR9G225	121
160	255	130	NSX400● + MicroLogic 1.3 M	2240	LC1G185	LC1D95	LR9G225	147
200	318	130	NSX400● + MicroLogic 1.3 M	2560	LC1G225	LC1G115	LR9G225	184
220	343	130	NSX630● + MicroLogic 1.3 M	3000	LC1G225	LC1G150	LR9G225	198
250	390	130	NSX630● + MicroLogic 1.3 M	3500	LC1G265	LC1G150	LR9G500	225
300	466	130	NSX630● + MicroLogic 1.3 M	4000	LC1G330	LC1G185	LR9G500	269
335	521	130	NS800● + MicroLogic 5.0 LR OFF	4800	LC1G330	LC1G185	LR9G500	301
355	554	130	NS800● + MicroLogic 5.0 LR OFF	4800	LC1G400	LC1G225	LR9G500	320

⁽¹⁾ Product type to be completed by replacing the ● with the breaking performance code:

Rated conditional short-circuit (kA)	NSX250●					NSX400●/ NSX630●				NS800L
	F	N	H	S	L	F	N	S	L	L
440 V	35	50	65	100	130	30	42	100	130	130

⁽²⁾ This setting is a general guidance, I_r and I_{rm} should be adjusted according to motor characteristics and conditions of use.

⁽³⁾ Refer to diagram in page 65.

TeSys Giga series – Device selection

Coordination tables

Optimized solutions for Star-Delta motor starters

Magnetic circuit breaker + Contactors + Overload relay

Contactor: **Maximum operating rate:** 30 starts/hour - **Maximum starting time:** 30 seconds.

The coordination table is for normal starting conditions (Class 10e/ 20e). For other heavy starting applications with long start times, please contact technical support.

RE17RMMWS timer to be used for Star-Delta starter application.

132 to 425 kW at 500 V: type 2 coordination (with ComPacT NSX/NS circuit breakers and LR9G overload relays)

Standard power ratings of 3-phase motors 50/60 Hz in category AC-3			Circuit breaker		Contactor Line (KM2) / Delta (KM3) ⁽³⁾	Contactor Star (KM1) ⁽³⁾	Thermal overload relay	
500 V			Product type ⁽¹⁾	I _{rm} ⁽²⁾	Product type		Product type	I _r setting ⁽²⁾
P	I _e	I _q (max)						
kW	A	kA		A				A
132	184	70	NSX400● + MicroLogic 1.3 M	1600	LC1G115	LC1D65	LR9G225	106
160	224	70	NSX400● + MicroLogic 1.3 M	1920	LC1G150	LC1D80	LR9G225	129
200	280	70	NSX400● + MicroLogic 1.3 M	2560	LC1G185	LC1G115	LR9G225	162
250	344	70	NSX630● + MicroLogic 1.3 M	3000	LC1G225	LC1G150	LR9G225	199
295	405	70	NSX630● + MicroLogic 1.3 M	3500	LC1G265	LC1G150	LR9G500	234
375	516	70	NS800● + MicroLogic 5.0	4800	LC1G330	LC1G185	LR9G500	298
425	584	70	NS800● + MicroLogic 5.0	4800	LC1G400	LC1G185	LR9G500	337

⁽¹⁾ Product type to be completed by replacing the ● with the breaking performance code:

Rated conditional short-circuit (kA)	NSX400●/ NSX630●					NS800●
Breaking performance code	F	N	H	S	L	L
500 V	25	30	50	65	70	100

⁽²⁾ This setting is a general guidance, I_r and I_{rm} should be adjusted according to motor characteristics and conditions of use.

⁽³⁾ Refer to diagram in page 65.

TeSys Giga series - Device selection

Coordination tables

Star-Delta motor starter - Common circuit diagrams

Star-Delta motor 'Power' circuit diagram

Thermal magnetic circuit breaker + contactors

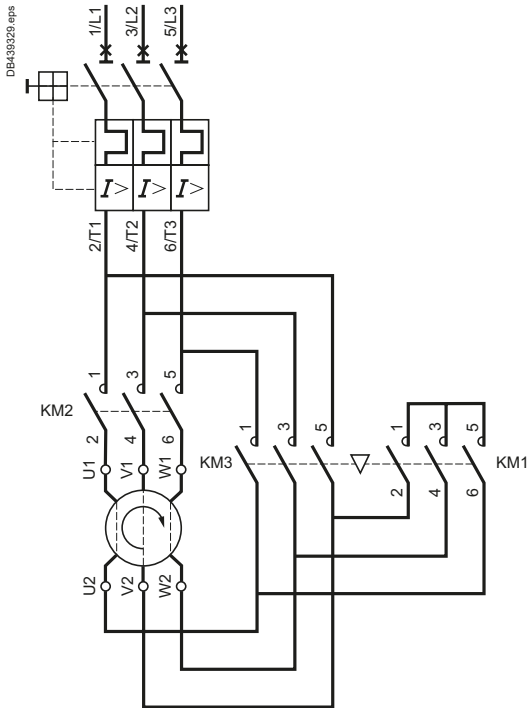

Magnetic circuit breaker + contactors + overload relay

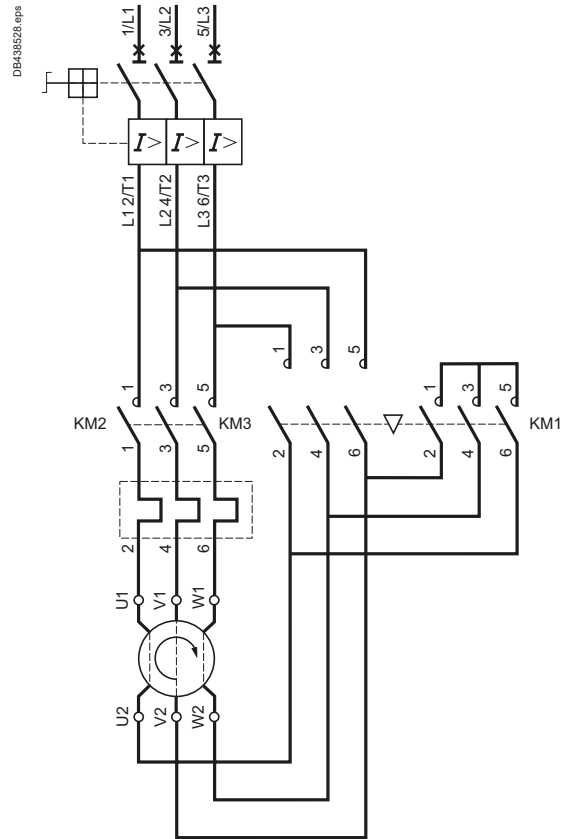

Star-Delta Motor 'Control' circuit diagram

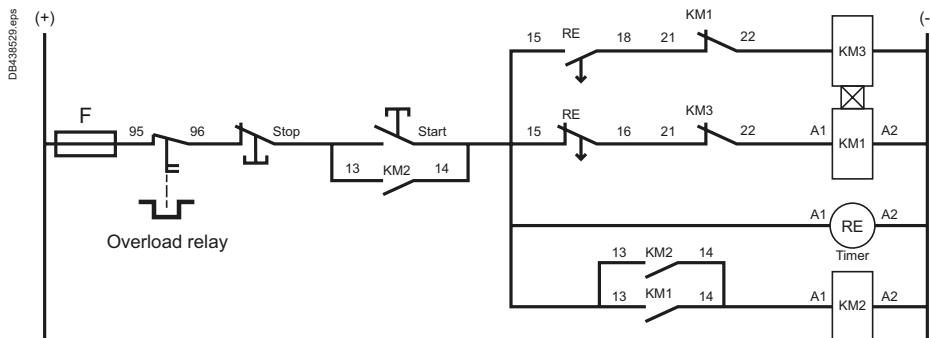

Recommended timing relay (RE): Zelio Timer ref. **RE17RMMWS** (12...240 V AC/DC 50/60 Hz – 8 AAC/DC contacts)

TeSys Giga series – Device selection

Coordination tables

Resistive load protection and control

Thermal magnetic circuit breakers + Contactors

275 to 1000 A up to 690 V: type 2 coordination (with ComPacT NSX or NS circuit breakers)				
Current ratings of 3-phase loads 50/60 Hz in category AC-1		Circuit breaker		Contactor
Up to 690 V, temperature ≤ 40 °C		Product type ⁽¹⁾	In	Product type
Ie	Iq (max)		A	
A	kA		A	
275	100	NSX400● + MicroLogic 2.3	400	LC1G150
305	100	NSX400● + MicroLogic 2.3	400	LC1G185
330	100	NSX400● + MicroLogic 2.3	400	LC1G225
385	100	NSX400● + MicroLogic 2.3	400	LC1G265
440	100	NSX630● + MicroLogic 2.3	630	LC1G330
550	100	NSX630● + MicroLogic 2.3	630	LC1G400
700	75	NS800● + MicroLogic 5.0	800	LC1G500
1000	100 ⁽²⁾	NS1000● + MicroLogic 5.0	1000	LC1G630

(1) Product type to be completed by replacing the ● with the breaking performance code:

Rated conditional short-circuit (kA)	NSX400●/ NSX630●								NS800●/NS1000●	
	F	N	H	S	L	R	HB1	HB2	L	LB
400 V	36	50	70	100	150	200	-	-	150	200
440 V	30	42	65	90	130	200	-	-	130	200
500 V	25	30	50	65	70	80	85	100	100	100
690 V	10	10	20	25	35	45	75	100	-	75

(2) Up to 500 V AC.

TeSys Giga series – Device selection

Coordination tables

Resistive load protection and control

Fuses (NFC, DIN type gG) + Contactors

275 to 1050 A up to 690 V: type 2 coordination (with NFC, DIN, type gG fuses)					
Current ratings of 3-phase loads 50/60 Hz in category AC-1		Switch-disconnector	gG fuse		Contactor
Up to 690 V, temperature ≤ 40 °C		Product type	Size	Rating	Product type
I _e	I _q (max)				
A	kA			A	
275	80	GS●QQ	2	315	LC1G150
305	80	GS●QQ	2	315	LC1G185
330	80	GS●QQ	2	400	LC1G225
385	80	GS●QQ	2	400	LC1G265
440	80	GS●S	3	500	LC1G330
550	80	GS●S	3	630	LC1G400
700	80	GS●V	4	800	LC1G500
1000	80	GS●V	4	1000	LC1G630
1050	80	GS●V	4	1250	LC1G800

TeSys Giga series - Device selection

Giga Contactors for various applications

Utilisation category AC-3

Operational current and power conforming to IEC ($\theta \leq 60^\circ\text{C}$)												
Contactor size			LC1 G115	LC1 G150	LC1 G185	LC1 G225	LC1 G265	LC1 G330	LC1 G400	LC1 G500	LC1 G630	LC1 G800
Maximum operational current in AC-3	$\leq 440\text{ V}$	A	115	150	185	225	265	330	400	500	630	800
Rated operational power P (standard motor power ratings)	230 V	kW	30	37	55	55	75	90	110	150	180	200
	400 V	kW	55	75	90	110	132	160	200	250	335	450
	415 V	kW	55	75	90	110	132	160	200	250	335	355
	440 V	kW	65	80	100	129	150	185	220	295	355	375
	500 V	kW	65	90	110	132	160	200	250	295	375	400
	690 V	kW	75	90	110	160	200	220	315	355	500	560
	1000 V	kW	–	75	75	132	160	185	220	335	450	450

Operational current and power conforming to UL, CSA ($\theta \leq 60^\circ\text{C}$)												
Contactor size			LC1 G115	LC1 G150	LC1 G185	LC1 G225	LC1 G265	LC1 G330	LC1 G400	LC1 G500	LC1 G630	LC1 G800
Maximum operational current in AC-3	$\leq 440\text{ V}$	A	115	150	185	225	265	330	400	500	630	800
Rated operational power P (standard motor power ratings 60 Hz)	200/208 V	HP	30	40	50	60	75	100	125	150	250	300
	230/240 V	HP	40	50	60	75	100	125	150	200	300	350
	460/480 V	HP	75	100	125	150	200	250	300	400	600	700
	575/600 V	HP	100	125	150	150	200	300	400	450	700	800

TeSys Giga series - Device selection

Giga Contactors for various applications

Utilisation category AC-3

Selection according to required electrical durability, in category AC-3e ($U_e \leq 440\text{ V}$)

Control of 3-phase asynchronous squirrel cage motors with breaking whilst running.

The current broken (I_c) in category AC-3e is equal to the rated operational current (I_e) of the motor.

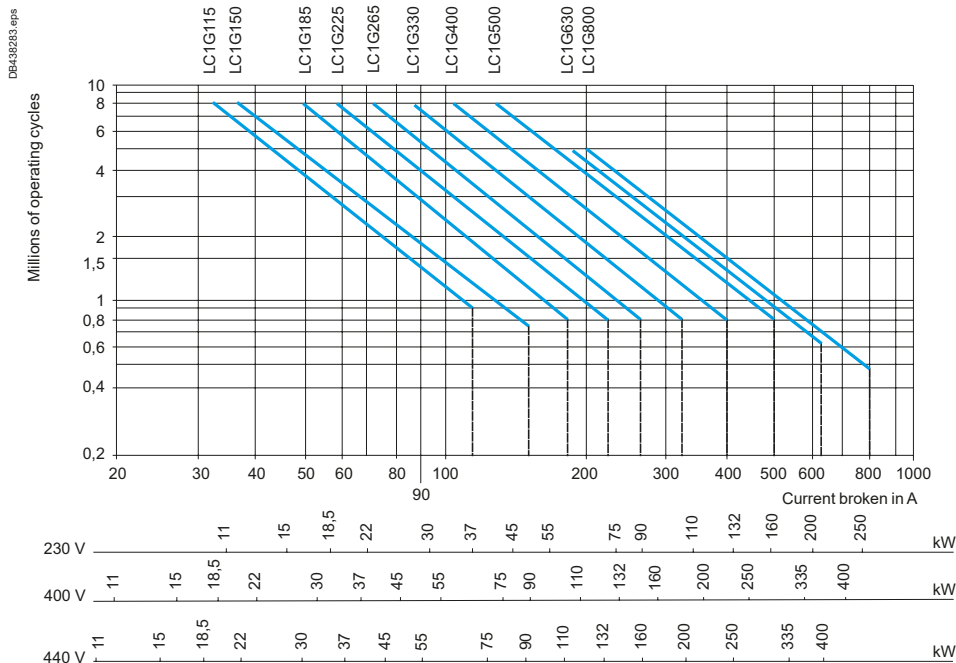

Operational power in kW - 50 Hz.

Example:

Asynchronous motor with $P = 132\text{ kW}$ - $U_e = 400\text{ V}$ - $I_e = 230\text{ A}$ - $I_c = I_e = 230\text{ A}$

1.8 million operating cycles required.

The above selection curves show the contactor rating needed: LC1G400.

Selection according to required electrical durability, in category AC-3 ($U_e = 660/690\text{ V}$)

Control of 3-phase asynchronous squirrel cage motors with breaking whilst running.

The current broken (I_c) in category AC-3 is equal to the rated operational current (I_e) of the motor.

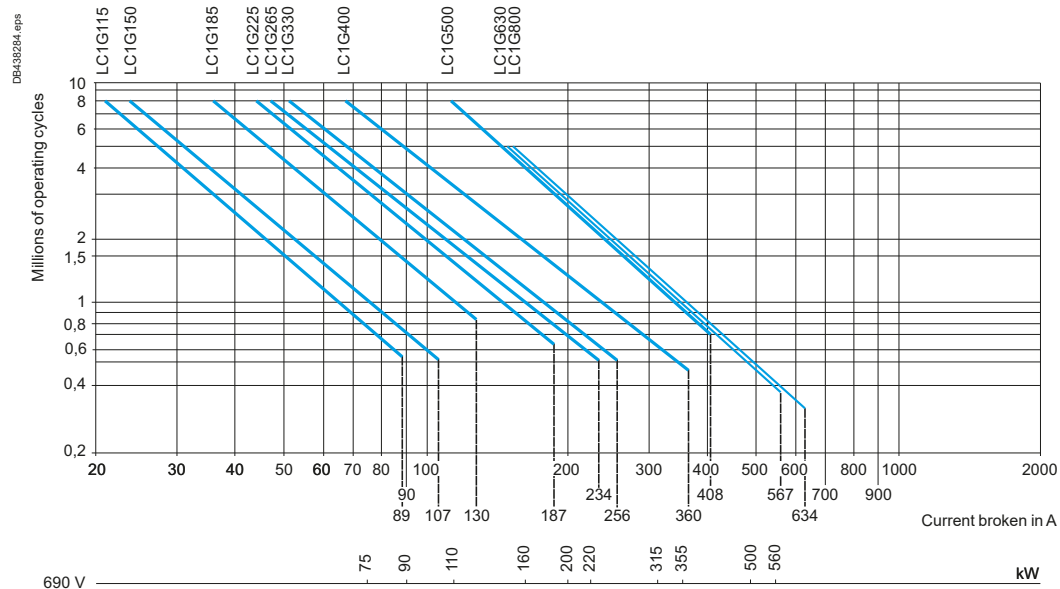

Example:

Asynchronous motor with $P = 200\text{ kW}$ - $U_e = 690\text{ V}$ - $I_e = 203\text{ A}$ - $I_c = I_e = 203\text{ A}$

1 million operating cycles required.

The above selection curves show the contactor rating needed: LC1G400.

TeSys Giga series - Device selection

Giga Contactors for various applications

Utilisation category AC-1

Maximum operational current (open-mounted device)

Contactor size			LC1 G115	LC1 G150	LC1 G185	LC1 G225	LC1 G265	LC1 G330	LC1 G400	LC1 G500	LC1 G630	LC1 G800
Maximum operating rate in operating cycles/hour			300	300	300	300	300	300	300	300	300	300
Operational current in AC-1 in A, according to the ambient temperature conforming to IEC 60947-1	≤ 40 °C	A	250	275	305	330	385	440	550	700	1050	1050
	≤ 60 °C	A⁽¹⁾	225	250	275	300	350	400	500	600	800	800
	≤ 70 °C	A⁽¹⁾	210	235	255	280	330	380	470	540	640	640
Maximum operational power ≤ 60 °C	230 V	kW	90	100	110	120	140	160	200	240	320	320
	240 V	kW	90	100	110	120	150	170	210	250	330	330
	400 V	kW	160	170	190	210	240	280	350	420	550	550
	415 V	kW	160	180	200	220	250	290	360	430	580	580
	440 V	kW	170	190	210	230	270	300	380	460	610	610
	500 V	kW	190	220	240	260	300	350	430	520	690	690
	690 V	kW	270	300	330	360	420	480	600	720	960	960
	1000 V	kW	390	430	480	520	610	690	870	1040	1390	1390

(1) LC1G115 to LC1G800: for temperature ≤ 60 °C... ≤ 70 °C max. coil control voltage = rated Uc.

Increase in operational current by parallel connection of poles

Apply the following coefficients to the currents or power values given above; these coefficients take into account an often unbalanced current distribution between the poles:

- 2-poles in parallel: K = 1.6
- 3-poles in parallel: K = 2.25
- 4-poles in parallel: K = 2.8

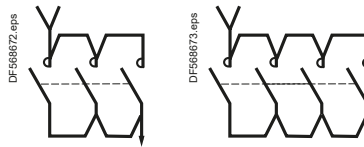

Selection according to required electrical durability, in category AC-1 (Ue ≤ 690 V, θ ≤ 40 °C)

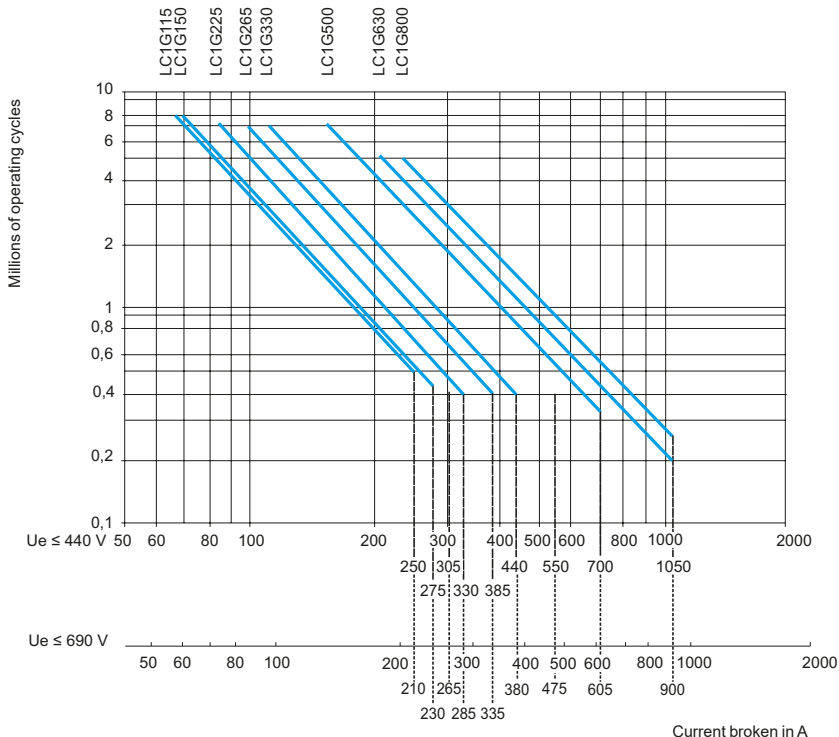

Example:

- Ue = 440 V - Ie = 500 A - θ ≤ 40 °C - Ic = Ie = 500 A
- 0.8 million operating cycles required
- the above selection curves show the contactor rating needed: LC1G630.

TeSys Giga series - Device selection

Giga Contactors for various applications

Utilisation category AC-2 or AC-4

Maximum breaking current

Category AC-2: slip ring motors - breaking the starting current.

Category AC-4: squirrel cage motors - breaking the starting current.

Contactor size			LC1 G115	LC1 G150	LC1 G185	LC1 G225	LC1 G265	LC1 G330	LC1 G400	LC1 G500	LC1 G630	LC1 G800
In category AC-4 (I _e max)	U _e ≤ 440 V I _e max broken = 6 x I motor	A	690	900	1110	1350	1590	1980	2400	3000	3780	4050
	440 V < U _e ≤ 690 V I _e max broken = 6 x I motor	A	530	640	780	1120	1400	1530	2160	2450	3400	3800

Depending on the maximum operating rate ⁽¹⁾ and the on-load factor, θ ≤ 60 °C ⁽²⁾

Duty Cycle [Cycle/h]	Load Factor [%]		LC1 G115	LC1 G150	LC1 G185	LC1 G225	LC1 G265	LC1 G330	LC1 G400	LC1 G500	LC1 G630	LC1 G800
150	15	A	319	400	478	562	641	758	869	1001	1124	1204
300	10	A	250	314	375	441	502	593	679	779	870	923
150	20	A	304	383	457	538	613	726	834	962	1083	1165
600	10	A	183	230	275	324	369	437	502	579	653	703
150	30	A	280	352	421	495	565	668	766	883	993	1065
1200 ⁽³⁾	10	A	131	164	196	230	262	309	353	404	449	473
150	55	A	239	300	358	421	480	568	652	750	842	902
2400 ⁽³⁾	10	A	120	151	181	212	242	287	329	379	426	457
150	85	A	208	261	312	368	420	498	572	661	748	809
3600 ⁽³⁾	10	A	120	151	181	212	242	287	329	379	426	457

⁽¹⁾ Do not exceed the maximum number of operating cycles.

⁽²⁾ For temperatures higher than 60 °C, use a maximum operating rate value equal to 80 % of the actual value when selecting from the tables.

⁽³⁾ Control Module can operate with higher duty cycle during limited time followed by proposed cooling time.

Operating cycles/hour	Cool time
1200	10 min
2400	30 min
3600	60 min

Counter current braking (plugging)

The current varies from the maximum plug-braking current to the rated motor current.

Making current: in the limits of the rated making and breaking capacities of the contactor.

As breaking normally takes place at a current value at or near the locked rotor current, the contactor can be selected using the criteria for categories AC-2 and AC-4.

Permissible AC-4 power rating for 200 000 operating cycles

Operational voltage		LC1 G115	LC1 G150	LC1 G185	LC1 G225	LC1 G265	LC1 G330	LC1 G400	LC1 G500	LC1 G630	LC1 G800
230 V	kW	11	11	15	18.5	22	22	30	37	37	37
400 V	kW	22	22	30	30	37	45	55	55	55	75
415 V	kW	22	22	30	30	37	45	55	55	55	75
440 V	kW	22	22	30	37	45	55	55	55	75	75
500 V	kW	11	11	18.5	22	22	30	45	45	55	55
690 V	kW	18.5	22	22	30	37	45	55	55	75	90

TeSys Giga series - Device selection

Giga Contactors for various applications

Utilisation category AC-2 or AC-4

Selection according to required electrical durability, in categories AC-2 or AC-4 ($U_e \leq 440\text{ V}$)

Control of 3-phase asynchronous squirrel cage motors (AC-4) or slip ring motors (AC-2) with breaking whilst motor stalled.

The current broken (I_c) in AC-4 is equal to $6 \times I_e$.

(I_e = rated operational current of the motor).

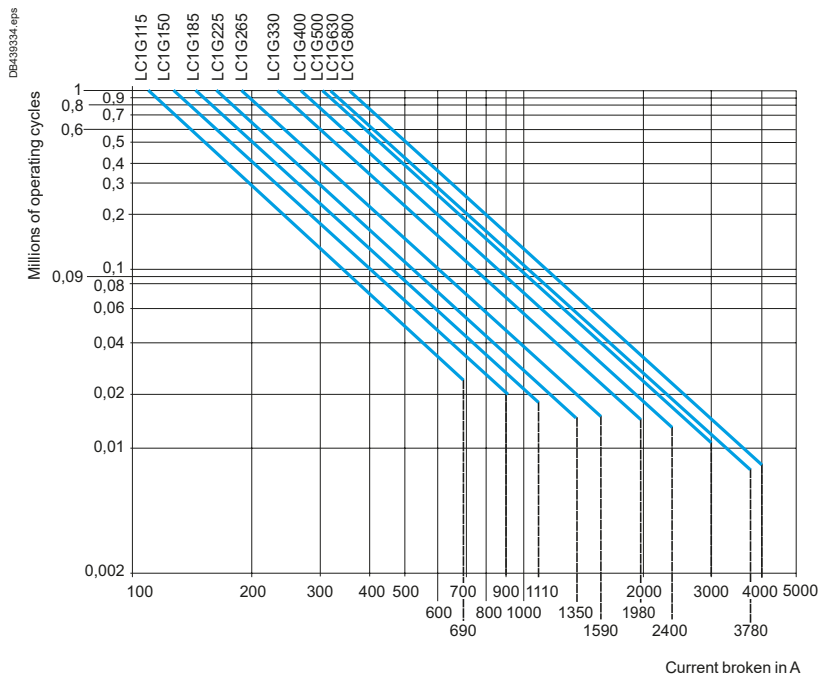

Example:

- asynchronous motor with $P = 132\text{ kW}$ - $U_e = 400\text{ V}$ - $I_e = 230\text{ A}$. $I_c = 6 \times I_e = 1380\text{ A}$. 30 000 operating cycles required.
- the above selection curves show the contactor rating needed: LC1G330.

Selection according to required electrical durability, use in category AC-4 ($440\text{ V} < U_e \leq 690\text{ V}$)

Control of 3-phase asynchronous squirrel cage motors with breaking whilst motor stalled.

The current broken (I_c) in AC-4 is equal to $6 \times I_e$ (I_e = rated operational current of the motor).

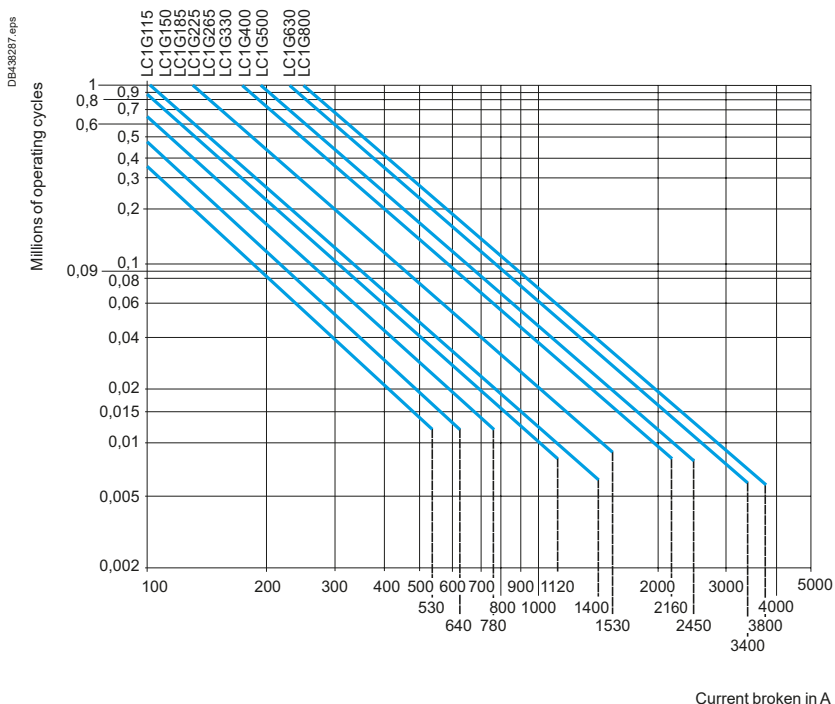

TeSys Giga series - Device selection

Giga Contactors for various applications

Utilisation category DC-1 to DC-5

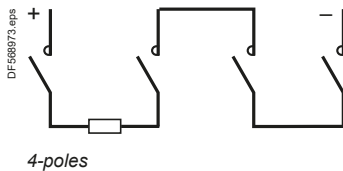
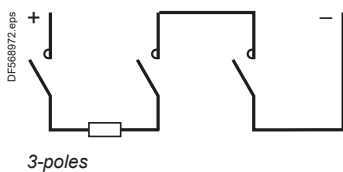
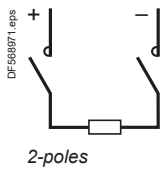
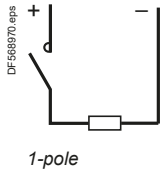

Rated operational current (Ie) in Amperes, in utilisation category DC-1, resistive loads: time constant $\frac{L}{R} \leq 1$ ms, ambient temperature ≤ 60 °C

Rated operational voltage Ue V	No. of poles connected in series	Contactor rating ⁽¹⁾									
		LC1 G115	LC1 G150	LC1 G185	LC1 G225	LC1 G265	LC1 G330	LC1 G400	LC1 G500	LC1 G630	LC1 G800
24	1	225	250	275	300	350	400	500	600	950	950
	2	225	250	275	300	350	400	500	600	950	950
	3	225	250	275	300	350	400	500	600	950	950
	4	225	250	275	300	350	400	500	600	950	950
48/75	1	225	250	275	300	350	400	500	600	950	950
	2	225	250	275	300	350	400	500	600	950	950
	3	225	250	275	300	350	400	500	600	950	950
	4	225	250	275	300	350	400	500	600	950	950
125	1	205	225	250	270	315	360	450	540	855	855
	2	205	225	250	270	315	360	450	540	855	855
	3	225	250	275	300	355	405	505	605	960	960
	4	225	250	275	300	355	405	505	605	960	960
250	1	-	-	-	-	-	-	-	-	-	-
	2	180	205	225	245	285	325	405	485	770	770
	3	225	250	275	300	350	400	500	600	950	950
	4	225	250	275	300	350	400	500	600	945	945
300	1	-	-	-	-	-	-	-	-	-	-
	2	-	-	-	-	-	-	-	-	-	-
	3	185	205	225	250	290	330	415	495	785	785
	4	225	250	275	300	350	400	500	600	950	950
460	1	-	-	-	-	-	-	-	-	-	-
	2	-	-	-	-	-	-	-	-	-	-
	3	-	-	-	-	-	-	-	-	-	-
	4	185	205	225	245	285	325	410	490	775	775

Rated operational current (Ie) in Amperes, in utilisation category DC-2 to DC-5, inductive loads: time constant $\frac{L}{R} \leq 15$ ms, ambient temperature ≤ 60 °C

Rated operational voltage Ue V	No. of poles connected in series	Contactor rating ⁽¹⁾									
		LC1 G115	LC1 G150	LC1 G185	LC1 G225	LC1 G265	LC1 G330	LC1 G400	LC1 G500	LC1 G630	LC1 G800
24	1	225	250	275	300	350	400	500	600	950	950
	2	225	250	275	300	350	400	500	600	950	950
	3	225	250	275	300	350	400	500	600	950	950
	4	225	250	275	300	350	400	500	600	950	950
48/75	1	225	250	275	300	350	400	500	600	950	950
	2	225	250	275	300	350	400	500	600	950	950
	3	225	250	275	300	350	400	500	600	950	950
	4	225	250	275	300	350	400	500	600	950	950
125	1	-	-	-	-	-	-	-	-	-	-
	2	190	210	230	250	290	335	420	500	795	795
	3	205	230	255	275	325	370	460	555	875	875
	4	205	230	255	275	325	370	460	555	875	875
250	1	-	-	-	-	-	-	-	-	-	-
	2	175	190	210	230	270	305	385	460	730	730
	3	185	210	230	250	290	335	415	500	790	790
	4	225	250	275	300	355	405	505	605	960	960
300	1	-	-	-	-	-	-	-	-	-	-
	2	-	-	-	-	-	-	-	-	-	-
	3	175	195	210	230	270	310	385	465	730	730
	4	225	250	275	300	350	400	500	600	950	950
460	1	-	-	-	-	-	-	-	-	-	-
	2	-	-	-	-	-	-	-	-	-	-
	3	-	-	-	-	-	-	-	-	-	-
	4	175	190	210	230	270	310	385	460	730	730

(1) Deca Green contactors are not validated for DC-1 to DC-5 applications.

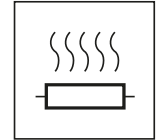

Selection

General

A heating circuit is a power switching circuit supplying one or more resistive heating elements switched by a contactor. The same general rules apply as for motor circuits, except that heating circuits are not normally subjected to overload currents. It is therefore only necessary to provide short-circuit protection.

Characteristics of heating elements

The examples below are based on resistive heating elements used for industrial furnaces or for the heating of buildings (infra-red or resistive radiant type, convactor heaters, closed loop heating circuits, etc.). The variation in resistance values between hot and cold states causes a current peak at switch-on which never exceeds 2 to 3 times the rated operational current (I_n). This initial peak does not recur during normal operation where subsequent switching is thermostatically controlled. The rated power and current of a heater are given for the normal operating temperature.

Protection

The steady state current drawn by a heating circuit is constant when the voltage is stable. In fact:

- it is unlikely that the number of loads in an existing circuit will be modified
- this type of circuit cannot create overloads. It is therefore only necessary to provide short-circuit protection.

This can be provided by:

- gG type fuses, or
- circuit breakers.

Nevertheless, it is always possible and sometimes more economical (smaller cable size) to protect the circuit by a thermal overload relay and associated aM type fuses.

Switching, control, protection

A heating element or group of heating elements of a given power may be either single-phase or 3-phase and may be supplied from a 230 V, 400 V, 690 V, 1000 V distribution system. The following 3 types of circuit arrangement are possible:

- single-phase, 2-pole switching
- single-phase, 4-pole switching
- 3-phase switching

Component selection according to the power switched

The combinations suggested below are based on an ambient temperature of 60 °C and for powers at the nominal voltage, but they also ensure switching in the event of prolonged overloads up to 1.05 U_e .

Single-phase, 2-pole switching				
Maximum power (kW)				Contactor rating
230 V	400 V	690 V	1000 V	
40	75	125	185	LC1G115
45	80	140	205	LC1G150
50	90	155	225	LC1G185
55	100	170	250	LC1G225
65	115	200	290	LC1G265
75	130	230	330	LC1G330
95	165	285	415	LC1G400
115	200	345	500	LC1G500
150	265	460	665	LC1G630
150	265	460	665	LC1G800

TeSys Giga series - Device selection

Giga Contactors for various applications

Heating

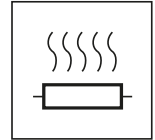

Component selection according to the power switched				
Single-phase, 4-pole switching				
Maximum power (kW)				Contactor rating
230 V	400 V	690 V	1000 V	
65	120	205	300	LC1G1154
75	130	230	330	LC1G1504
80	145	250	365	LC1G1854
90	160	275	400	LC1G2254
105	185	320	465	LC1G2654
120	210	365	530	LC1G3304
150	265	460	665	LC1G4004
180	320	550	800	LC1G5004
245	425	735	1065	LC1G6304
245	425	735	1065	LC1G8004
3-phase switching				
Maximum power (kW)				Contactor rating
230 V	400 V	690 V	1000 V	
70	125	220	320	LC1G115
80	140	245	360	LC1G150
90	155	270	395	LC1G185
95	170	295	430	LC1G225
115	200	345	505	LC1G265
130	230	395	575	LC1G330
165	285	495	720	LC1G400
195	345	595	865	LC1G500
265	460	795	1150	LC1G630
265	460	795	1150	LC1G800

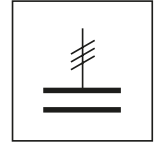

Capacitors, together with the circuits to which they are connected, form oscillatory circuits which can, at the moment of switch-on, give rise to high transient currents (> 180 In) at high frequencies (1 to 15 kHz).

As a general rule, the peak current on energisation is lower when:

- the mains inductances are high
- the line transformer ratings are low
- the transformer short-circuit voltage is high
- the ratio between the sum of the ratings of the capacitors already switched into the circuit and that of the capacitor to be switched in is small (for multiple step capacitor banks).

In accordance with standards IEC 60831-1, the switching contactor must be able to withstand a continuous current of 1.5 times the rated current of the capacitor bank step being switched.

The rated operational powers given in the tables below take this overload into account. Short-circuit protection is normally provided by gI type HPC fuses rated at 1.7 to 2 In.

Contactor applications

Operating conditions

Capacitors are directly switched. **The values below indicate the maximum peak current at switch-on.**

An inductor may be inserted in each of the three phases supplying the capacitors to reduce the peak current, if necessary.

Inductance values are determined according to the selected operating temperature.

Power factor correction by a single-step capacitor bank

The use of a choke inductor is unnecessary: the inductance of the mains supply is adequate to limit the peak to a value compatible with the contactor characteristics.

Power factor correction by a multiple-step capacitor bank

If a standard contactor is used, insert a choke inductor in each of the three phases of each step.

Maximum operational power of contactors

Standard contactors

Maximum operating rate: 120 operating cycles/hour.

Electrical durability at maximum load: 100 000 operating cycles.

With choke inductors connected, where necessary.

Operational power at 50/60 Hz						Max. peak current	Contactor rating
$\theta \leq 40\text{ °C}^{(1)}$			$\theta \leq 60\text{ °C}^{(1)}$				
220/240 V	400/440 V	600/690 V	220/240 V	400/440 V	600/690 V	A	
kvAR	kvAR	kvAR	kvAR	kvAR	kvAR		
50	90	150	45	80	135	1900	LC1G115
55	100	165	50	90	150	2480	LC1G150
60	110	185	55	100	165	3050	LC1G185
65	120	200	60	110	180	3710	LC1G225
75	140	235	70	125	210	4370	LC1G265
85	160	265	80	145	240	5450	LC1G330
110	200	335	100	185	305	6600	LC1G400
140	255	425	120	220	365	8250	LC1G500
210	385	640	160	295	485	10400	LC1G630
210	385	640	160	295	485	13200	LC1G800

(1) Upper limit of temperature category conforming to IEC 60831-1.



Green Premium™

An industry leading portfolio of offers delivering sustainable value



More than 75% of our product sales offer superior transparency on the material content, regulatory information and environmental impact of our products:

- RoHS compliance
- REACH substance information
- Industry leading # of PEP's*
- Circularity instructions



Discover what we mean by green
Check your products!

The Green Premium program stands for our commitment to deliver customer valued sustainable performance. It has been upgraded with recognized environmental claims and extended to cover all offers including Products, Services and Solutions.

CO₂ and P&L impact through... Resource Performance

Green Premium brings improved resource efficiency throughout an asset's life-cycle. This includes efficient use of energy and natural resources, along with the minimization of CO₂ emissions.

Cost of ownership optimization through... Circular Performance

We're helping our customers optimize the total cost of ownership of their assets. To do this, we provide IoT-enabled solutions, as well as upgrade, repair, retrofit, and re-manufacture services.

Peace of mind through... Well-being Performance

Green Premium products are RoHS and REACH compliant. We're going beyond regulatory compliance with step-by-step substitution of certain materials and substances from our products.

Improved sales through... Differentiation

Green Premium delivers strong value propositions through third-party labels and services. By collaborating with third-party organizations we can support our customers in meeting their sustainability goals such as green building certifications.

*PEP: Product Environmental Profile (i.e. Environmental Product Declaration)

Life Is On | **Schneider**
Electric

Schneider Electric Industries SAS

35, rue Joseph Monier
CS 30323
92506 Rueil Malmaison Cedex
France

RCS Nanterre 954 503 439
Capital social 928 298 512 €
www.se.com

12 - 2021

© 2022 - Schneider Electric. All Rights Reserved.
All trademarks are owned by Schneider Electric Industries SAS or its affiliated companies.
Document reference: LVCATESGEN

This document has been
printed on recycled paper

