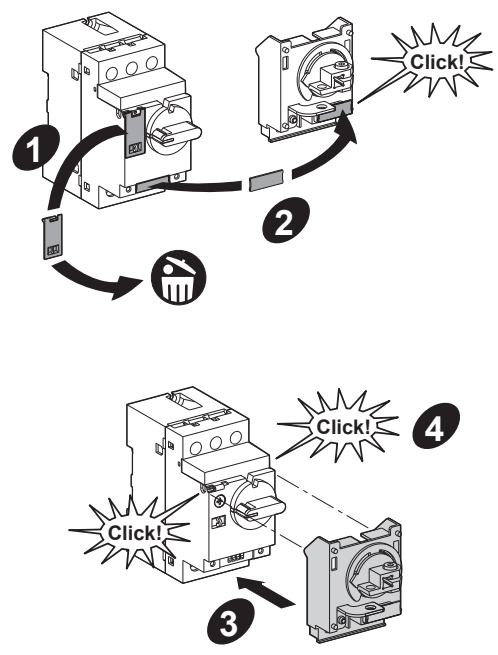
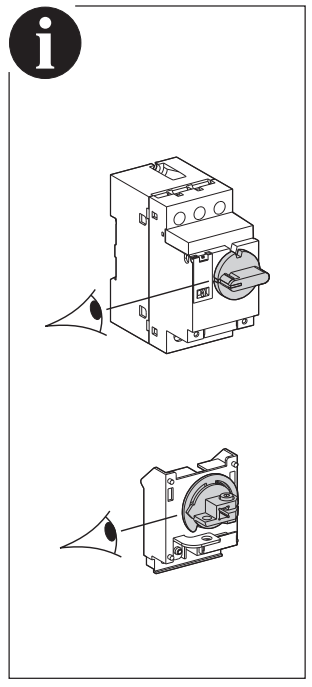
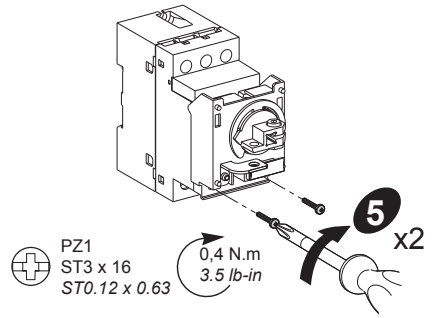
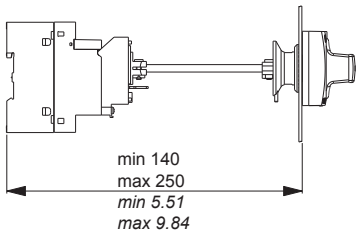
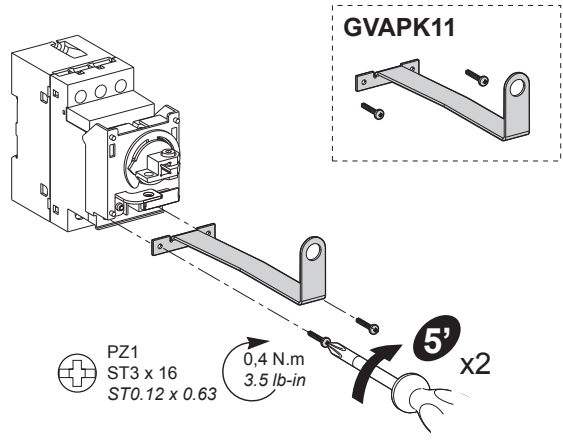
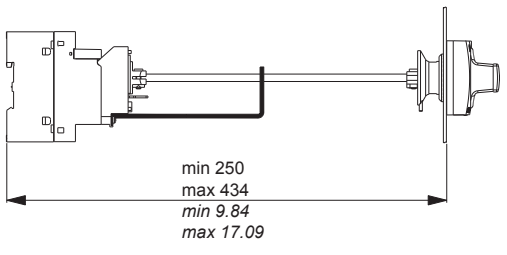
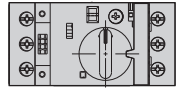
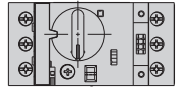
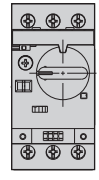
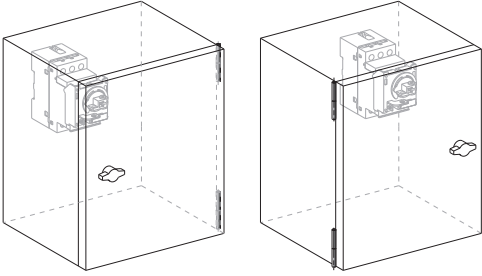

<p><b>PLEASE NOTE</b> Electrical equipment should be installed, operated, serviced, and maintained only by qualified personnel. No responsibility is assumed by Schneider Electric for any consequences arising out of the use of this material.</p>	<p><b>REMARQUE IMPORTANTE</b> Les équipements électriques doivent être installés, exploités et entretenus par un personnel d'entretien qualifié. Schneider Electric n'assume aucune responsabilité des conséquences éventuelles découlant de l'utilisation de cette documentation.</p>	<p><b>TENGA EN CUENTA</b> Sólo el personal de servicio cualificado podrá instalar, utilizar, reparar y mantener el equipo eléctrico. Schneider Electric no asume las responsabilidades que pudieran surgir como consecuencia de la utilización de este material.</p>	<p><b>BITTE BEACHTEN</b> Elektrische Geräte dürfen nur von Fachpersonal installiert, betrieben, gewartet und instand gesetzt werden. Schneider Electric haftet nicht für Schäden, die aufgrund der Verwendung dieses Materials entstehen.</p>
<p><b>NOTA IMPORTANTE</b> Le apparecchiature elettriche devono essere installate, usate e riparate solo da personale qualificato. Schneider Electric non assume nessuna responsabilità per qualunque conseguenza derivante dall'uso di questo materiale.</p>	<p><b>NOTA</b> A instalação, utilização e manutenção do equipamento eléctrico devem ser efectuadas exclusivamente por pessoal qualificado. A Schneider Electric não assume qualquer responsabilidade pelas consequências resultantes da utilização deste material.</p>	<p><b>请注意</b> 电气设备的安装、操作、维修和维护工作仅限于合格人员 执行。Schneider Electric 不承担由于使用本资料所引起的任何后果。</p>	<p><b>ВАЖНО</b> Электрическое оборудование должно обслуживаться квалифицированным персоналом. Компания Schneider Electric не несет ответственности за последствия, связанные с использованием данной документации. Данная документация не предназначена для использования в качестве руководства людьми, не прошедшими какого-либо обучения.</p>

© 2016 Schneider Electric - All rights reserved.

<p><b>▲▲ DANGER / DANGER / PELIGRO / GEFAHR / PERICOLO / PERIGO / 危險 / ОПАСНО</b></p>			
<p><b>HAZARD OF ELECTRIC SHOCK, EXPLOSION, OR ARC FLASH</b> ● Apply appropriate personal protective equipment (PPE) and follow safe electrical work practices. For use in the USA, refer to NFPA 70E. ● This equipment must be installed and serviced only by qualified electrical personnel. ● Turn off all power supplying this equipment before working on or inside equipment. ● Always use a properly rated voltage sensing device to confirm power is off. <b>Failure to follow these instructions will result in death or serious injury.</b></p>	<p><b>RISQUE D'ÉLECTROCUTION, D'EXPLOSION OU D'ÉCLAIR D'ARC ÉLECTRIQUE</b> ● Portez un équipement de protection personnel (EPP) approprié et observez les méthodes de travail électrique sécuritaire. Aux USA, voir NFPA 70E. ● L'installation et l'entretien de cet appareil ne doivent être effectués que par du personnel qualifié. ● Coupez l'alimentation de l'appareil avant d'y travailler. ● Utilisez toujours un dispositif de détection de tension à valeur nominale appropriée pour s'assurer que toute l'alimentation est coupée. <b>Le non-respect de ces instructions provoquera la mort ou des blessures graves.</b></p>	<p><b>PELIGRO DE DESCARGA ELÉCTRICA, EXPLOSIÓN O ARCO ELÉCTRICO</b> ● Utilice equipo de protección personal (EPP) apropiado y siga las prácticas de seguridad eléctrica establecidas por su compañía. Para su utilización en EE.UU., véase NFPA 70E. ● Solamente el personal de mantenimiento eléctrico especializado deberá instalar y prestar servicio de mantenimiento a este equipo. ● Desenergice el equipo antes de realizar cualquier trabajo en él. ● Siempre utilice un dispositivo detector de tensión adecuado para confirmar la desenergización del equipo. <b>Si no se siguen estas instrucciones provocará lesiones graves o incluso la muerte.</b></p>	<p><b>GEFAHR VON ELEKTRISCHEM SCHLAG, EXPLOSION ODER LICHTBOGEN</b> ● Tragen Sie persönliche Schutzausrüstung (PSA) und befolgen Sie sichere Verfahren im Umgang mit Elektrogeräten. Für die Verwendung in den USA siehe NFPA 70E. ● Dieses Gerät darf nur von qualifizierten Elektrikern installiert und gewartet werden. ● Schalten Sie vor Arbeiten am bzw. im Innern des Geräts die gesamte Spannungsversorgung ab. ● Verwenden Sie stets ein Spannungsprüfgerät mit der korrekten Bemessungsspannung, um festzustellen, ob die Spannungsversorgung wirklich abgeschaltet ist. <b>Die Nichtbeachtung dieser Anweisungen führt zu Tod oder schwereren Verletzungen.</b></p>
<p><b>RISCHIO DI SCARICA ELETTRICA, ESPLOSIONE O ARCO ELETTRICO</b> ● Utilizzare dispositivi di protezione individuale (DPI) adeguati e adottare le pratiche di sicurezza per lavori elettrici. Per l'utilizzo negli USA, fare riferimento a NFPA 70E. ● Installazione e manutenzione di questa apparecchiatura devono essere affidate solo ad elettricisti qualificati. ● Scollegare l'alimentazione elettrica prima di eseguire lavori sull'apparecchiatura o al suo interno. ● Per verificare che l'alimentazione sia isolata usare sempre un rilevatore di tensione correttamente tarato. <b>Il mancato rispetto di queste istruzioni provocherà morte o gravi infortuni.</b></p>	<p><b>RISCO DE ELECTROCUSÃO, DE EXPLOSAÇÃO, OU DE ARCO ELÉCTRICO</b> ● Utilize equipamento de protecção pessoal (PPE) e siga os métodos de segurança eléctrica. Para utilização nos EUA, consulte NFPA 70E. ● A instalação e manutenção deste equipamento só devem ser efectuadas por pessoal qualificado. ● Desligue todas as fontes de alimentação deste equipamento antes de trabalhar no equipamento ou no seu interior. ● Utilize sempre um dispositivo de detecção da tensão nominal adequada para confirmar se a alimentação está desligada. <b>A não observância destas instruções resultará em morte, ou ferimentos graves.</b></p>	<p>可能有触电、爆炸或者电弧灼伤的危险 ● 采用适当的个人防护设备 (PPE) 并遵循电气作业安全守则。如果要在美国使用, 请参阅 NFPA 70E。 ● 只有具备相应资质的电气人员才能安装和维修该设备。 ● 在该设备表面或内部工作之前, 请关闭设备的全部电源。 ● 确保使用合适的额定电压传感器确认电源已关闭。不遵循上述说明将导致人员伤亡。</p>	<p><b>Опасность поражением электрическим током, опасность взрыва или вспышки дуги.</b> ● Используйте подходящие средства индивидуальной защиты (СИЗ) и соблюдайте технику безопасности при электротехнических работах. В случае использования в США см. NFPA 70E. ● Это оборудование могут устанавливать и обслуживать только квалифицированные электрики. ● Отключите питание до начала работы снаружи или внутри данного оборудования. ● Всегда пользуйтесь надлежащим датчиком номинального напряжения для определения отсутствия питания. <b>Несоблюдение этих инструкций приведет к смерти или серьезной травме</b></p>

**A****GV2APN●●****GV2APN●● + GVAPK11**

**B****i**

OK

OK

OK

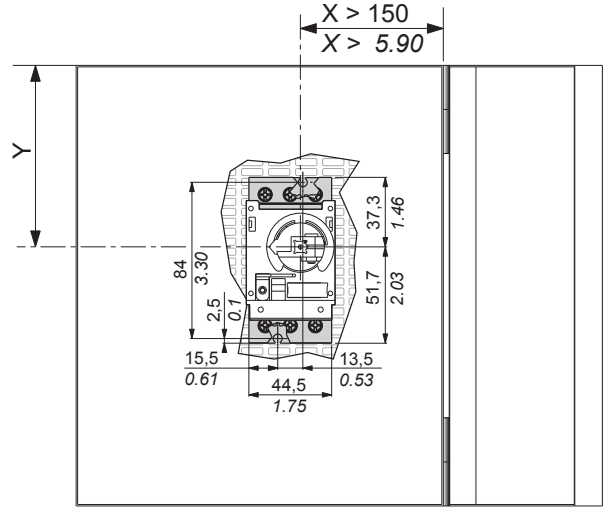
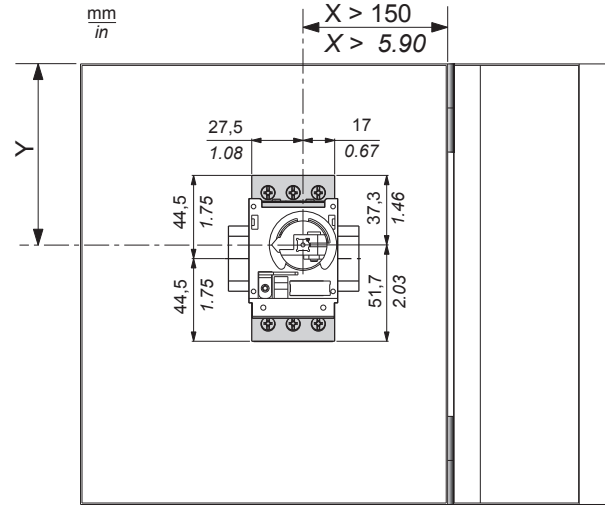
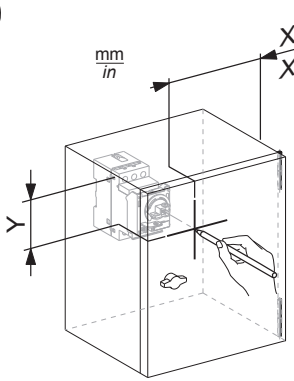
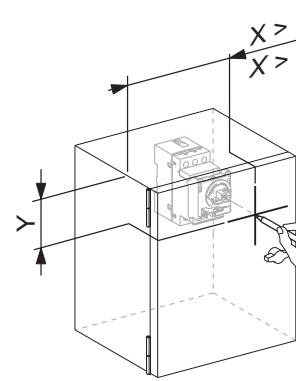
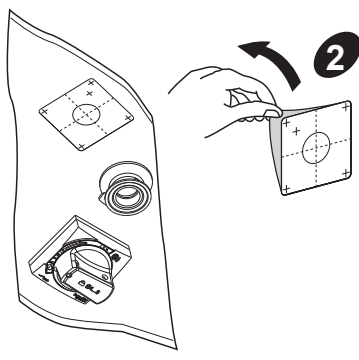
**C****1****1'****2****i**

$$0.5 < e < 4$$

$$0.02 < t < 0.16$$

OK

GV2APN01  
GV2APN02

GV2APN04

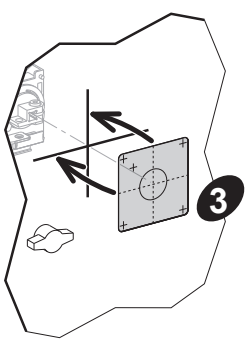
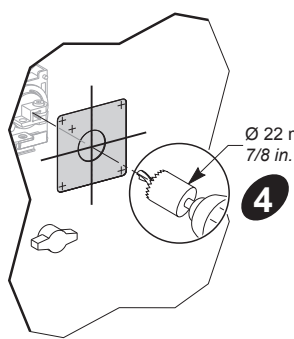
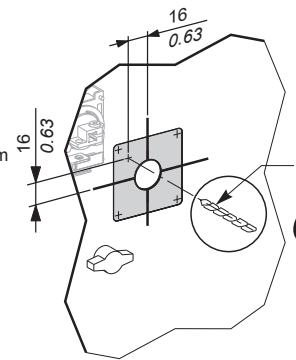
**3****4****5**

x1

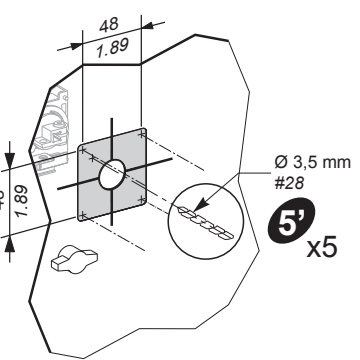
**5'**

x5

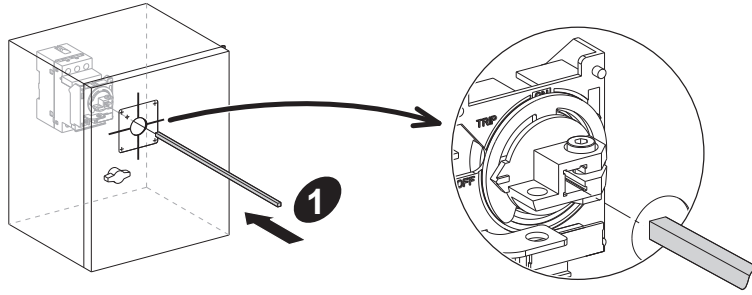
**D**

GV2APN●●

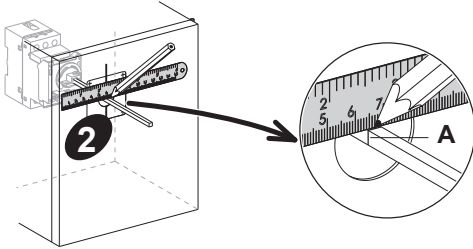

GV2APN●● + GVAPP1

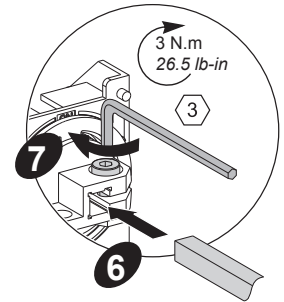
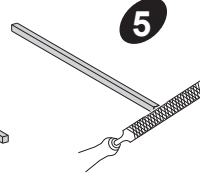
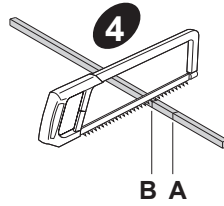
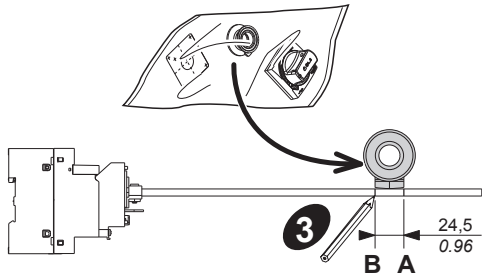
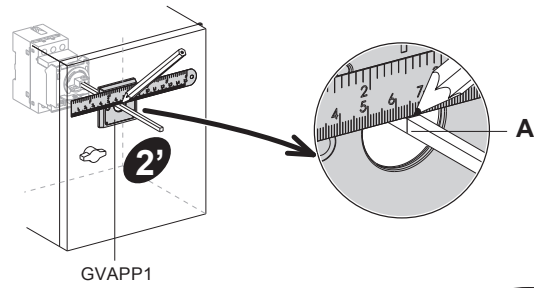
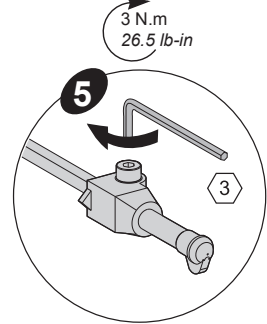
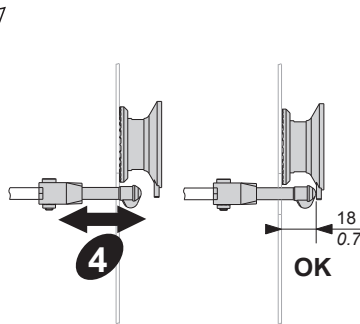
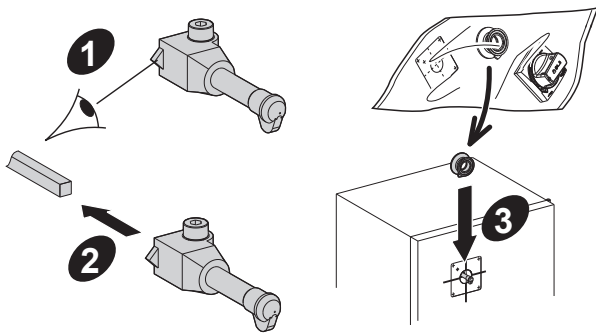
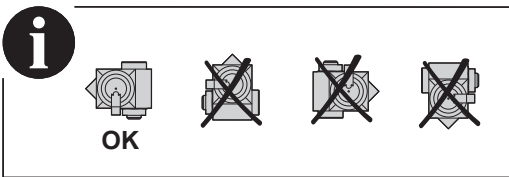
**E****i**

x1 max. Ø4 mm  
x1 max. Ø0.16 in.

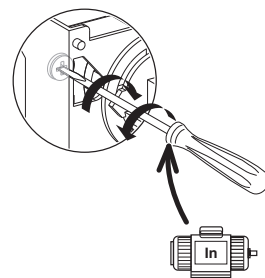
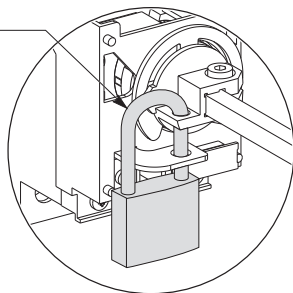

**i**



**F** GV2APN01, GV2APN02

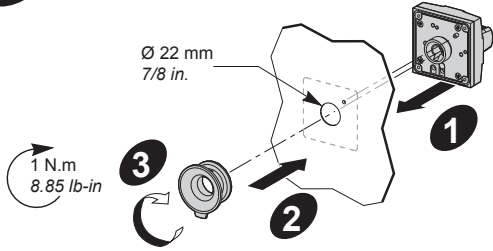

**F'** GV2APN04

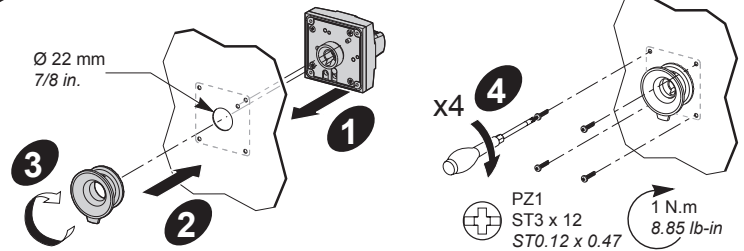

**F''** GV2APN01, GV2APN02 + GVAPP1

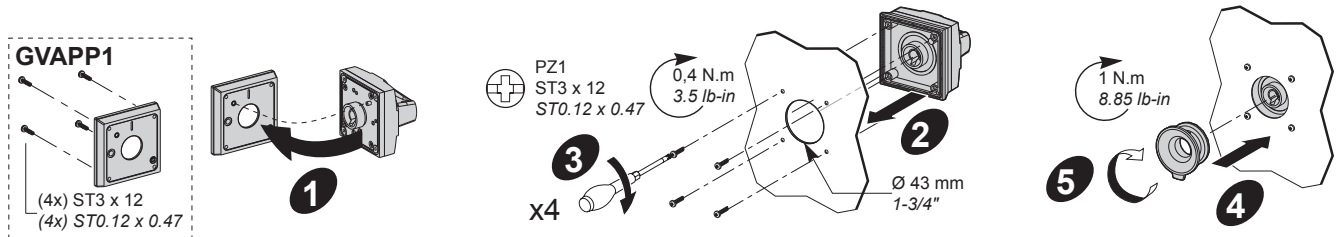

**G**

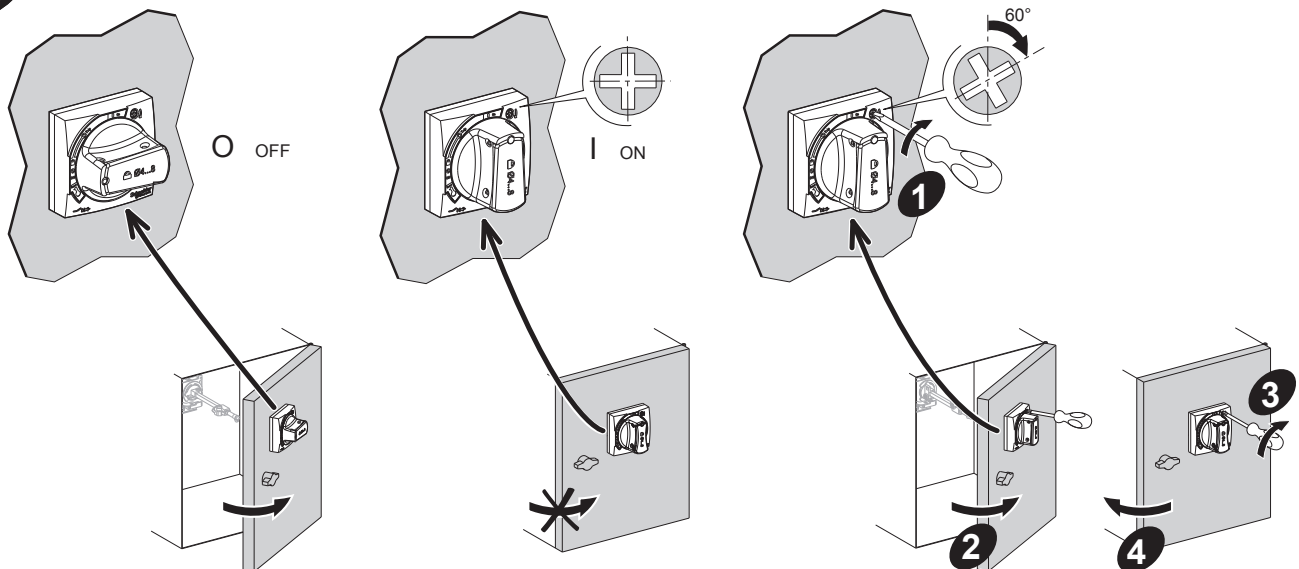

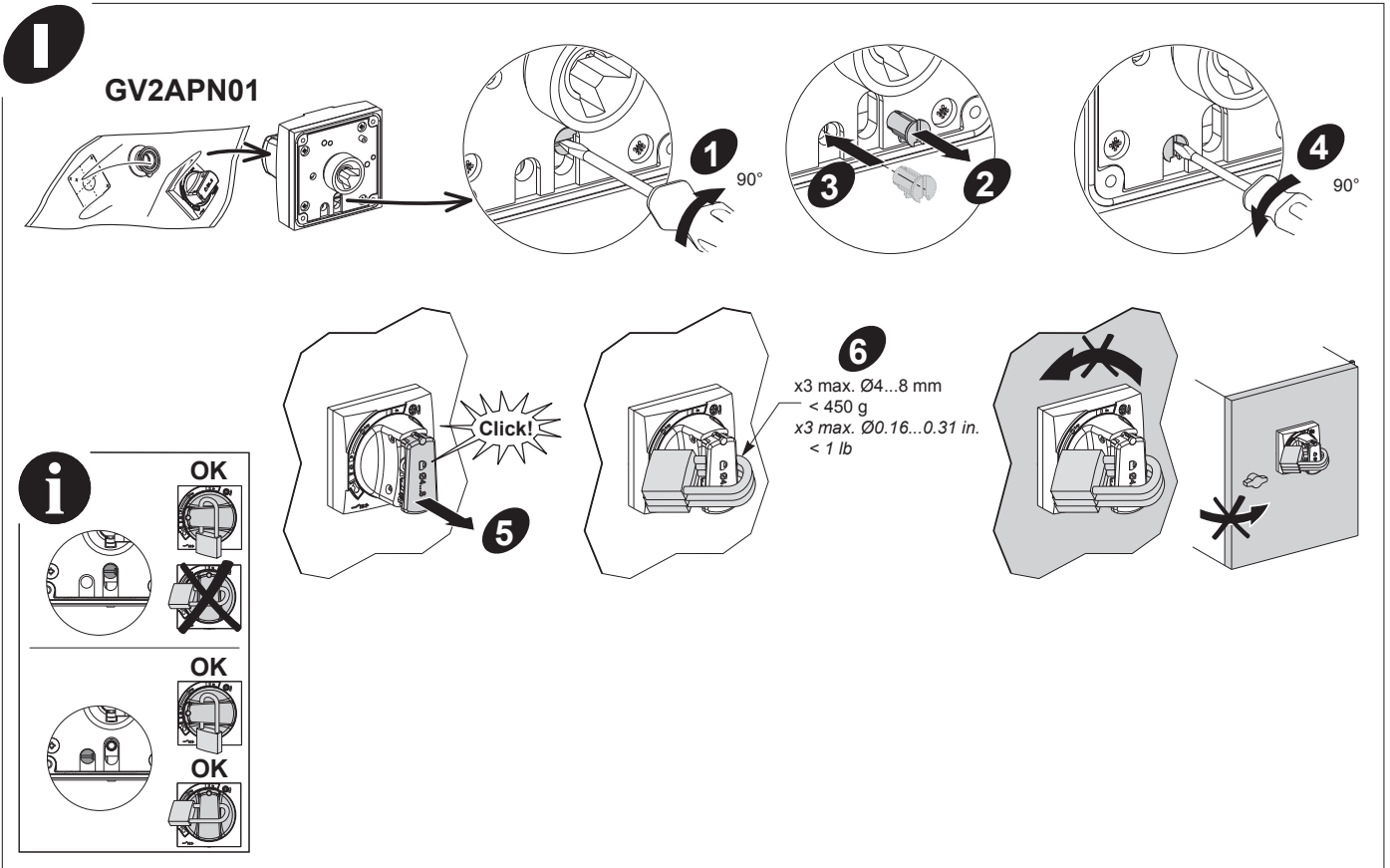
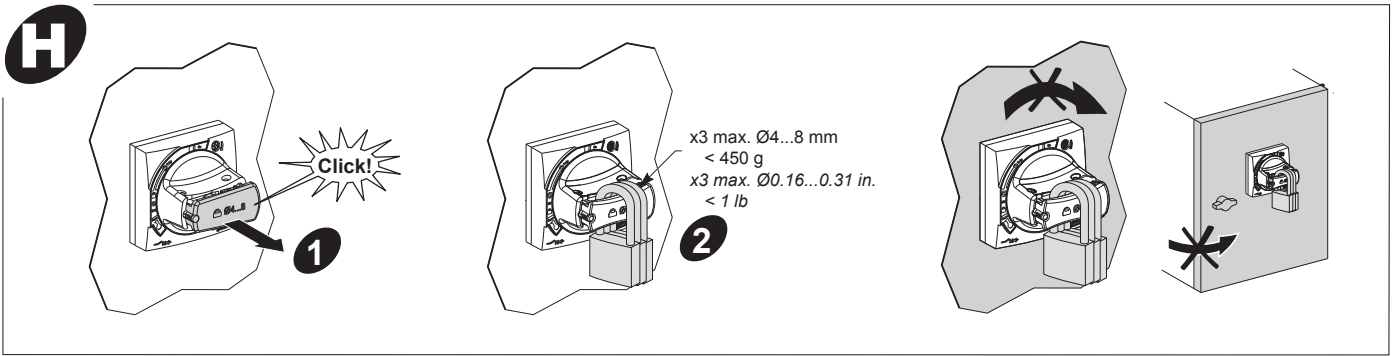

<p><b>⚠ DANGER / DANGER / PELIGRO / GEFAHR / PERICOLO / PERIGO / 危險 / ОПАСНО</b></p>			
<p><b>HAZARD OF ELECTRIC SHOCK, EXPLOSION, OR ARC FLASH</b> After installation:</p> <ul style="list-style-type: none"> <li>● Replace all devices, doors, and covers before turning on power to this equipment.</li> <li>● Always check that the handle is positioned correctly in relation to the circuit breaker.</li> <li>● Check that the door cannot be opened when the door interlock mechanism and the circuit breaker are set to ON.</li> </ul> <p><b>Failure to follow these instructions will result in death or serious injury.</b></p>	<p><b>RISQUE D'ÉLECTROCUTION, D'EXPLOSION OU D'ÉCLAIR D'ARC ÉLECTRIQUE</b> Après installation :</p> <ul style="list-style-type: none"> <li>● Remplacez tous les dispositifs, les portes et les couvercles avant de mettre l'appareil sous tension.</li> <li>● Vérifiez toujours la cohérence de la position de la poignée par rapport à celle du disjoncteur.</li> <li>● Vérifiez que la porte ne peut pas être ouverte lorsque la commande sur porte et le disjoncteur sont en position ON.</li> </ul> <p><b>Le non-respect de ces instructions provoquera la mort ou des blessures graves.</b></p>	<p><b>PELIGRO DE DESCARGA ELÉCTRICA, EXPLOSIÓN O ARCO ELÉCTRICO ELECTRIQUE</b> Después de la instalación:</p> <ul style="list-style-type: none"> <li>● Antes de energizar el equipo, vuelva a colocar todos los dispositivos, las puertas y los frentes.</li> <li>● Compruebe siempre que la posición de la manilla sea correcta respecto a la del disyuntor.</li> <li>● Compruebe que la puerta no se pueda abrir cuando el control sobre la puerta y el disyuntor estén en la posición ON.</li> </ul> <p><b>Si no se siguen estas instrucciones provocará lesiones graves o incluso la muerte.</b></p>	<p><b>GEFAHR VON ELEKTRISCHEM SCHLAG, EXPLOSION ODER LICHTBOGEN</b> Nach der Installation:</p> <ul style="list-style-type: none"> <li>● Bringen Sie alle Vorrichtungen, Türen und Abdeckungen wieder an, bevor Sie das Gerät einschalten.</li> <li>● Prüfen Sie stets, ob sich der Griff in Bezug auf den Leistungsschalter in der korrekten Stellung befindet.</li> <li>● Vergewissern Sie sich, dass die Tür nicht geöffnet werden kann, wenn der Türverriegelungsmechanismus und der Leistungsschalter auf „ON“ (EIN) gesetzt sind.</li> </ul> <p><b>Die Nichtbeachtung dieser Anweisungen führt zu Tod oder schwereren Verletzungen.</b></p>
<p><b>RISCHIO DI SCARICA ELETTRICA, ESPLOSIONE O ARCO ELETTRICO</b> Dopo l'installazione:</p> <ul style="list-style-type: none"> <li>● Prima di collegare l'apparecchiatura all'alimentazione elettrica rimontare tutti i dispositivi, gli sportelli e i copercchi.</li> <li>● Verificare sempre che la manopola sia posizionata correttamente rispetto all'interruttore.</li> <li>● Controllare che lo sportello non possa essere aperto quando il meccanismo di interblocco sportello e l'interruttore sono posizionati su ON.</li> </ul> <p><b>Il mancato rispetto di queste istruzioni provocherà morte o gravi infortuni.</b></p>	<p><b>RISCO DE ELECTROCUSSÃO, DE EXPLOSIÃO, OU DE ARCO ELÉCTRICO</b> Após a instalação:</p> <ul style="list-style-type: none"> <li>● Substitua todos os dispositivos, portas e tampas antes de ligar a alimentação deste equipamento.</li> <li>● Verifique sempre se o manipulador se encontra correctamente posicionado em relação ao disjuntor.</li> <li>● Verifique se não é possível abrir a porta quando o mecanismo de interbloqueio da porta e o disjuntor se encontrarem ON.</li> </ul> <p><b>A não observância destas instruções resultará em morte, ou ferimentos graves.</b></p>	<p>可能有触电、爆炸或者电弧灼伤的危險 安裝之后:</p> <ul style="list-style-type: none"> <li>● 更換所有設備、門和蓋，然後再打開該設備的電源。</li> <li>● 確保手柄放置在正確位置，應以斷路器為參照。</li> <li>● 檢查當門鎖裝置和斷路器設置為 ON 時，門是否無法打開。</li> </ul> <p><b>不遵循上述說明將導致人員傷亡。</b></p>	<p><b>Опасность поражением электрическим током, опасность взрыва или вспышки дуги.</b> После установки:</p> <ul style="list-style-type: none"> <li>● Перед включением питания этого оборудования установите обратно все устройства, дверцы и крышки.</li> <li>● Обязательно проверяйте, что рукоятка правильно расположена относительно автомата защиты.</li> <li>● проверьте, что дверь невозможно открыть при включенном механизме блокировки двери и автомате защиты цепи (положение ON).</li> </ul> <p><b>Несоблюдение этих инструкций приведет к смерти или серьезной травме.</b></p>