

PowerLogic™ Branch Circuit Power Meter (BCPM) Panel Board Monitoring System Z205396-0H

Installation Guide

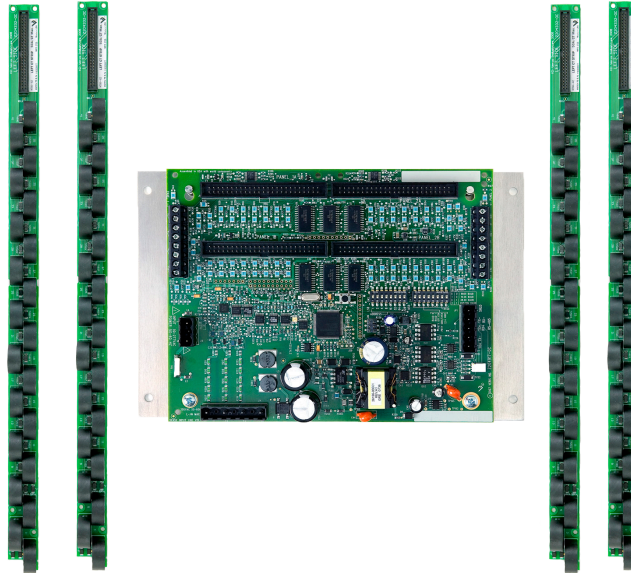

Other current sensor strip sizes available.

HAZARD CATEGORIES AND SPECIAL SYMBOLS

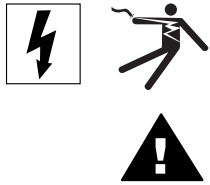

Read these instructions carefully and look at the equipment to become familiar with the device before trying to install, operate, service or maintain it. The following special messages may appear throughout this bulletin or on the equipment to warn of potential hazards or to call attention to information that clarifies or simplifies a procedure.

The addition of either symbol to a “Danger” or “Warning” safety label indicates that an electrical hazard exists which will result in personal injury if the instructions are not followed.

This is the safety alert symbol. It is used to alert you to potential personal injury hazards. Obey all safety messages that follow this symbol to avoid possible injury or death.

⚠ DANGER

DANGER indicates an imminently hazardous situation which, if not avoided, **will result in** death or serious injury.

⚠ WARNING

WARNING indicates a potentially hazardous situation which, if not avoided, **can result in** death or serious injury.

⚠ CAUTION

CAUTION indicates a potentially hazardous situation which, if not avoided, **can result in** minor or moderate injury.

CAUTION

CAUTION, used without the safety alert symbol, indicates a potentially hazardous situation which, if not avoided, **can result in** property damage.

NOTE: Provides additional information to clarify or simplify a procedure.

PLEASE NOTE

Electrical equipment should be installed, operated, serviced, and maintained only by qualified personnel. No responsibility is assumed by Schneider Electric for any consequences arising out of the use of this material.

FCC NOTICE

This equipment has been tested and found to comply with the limits for a Class A digital device, pursuant to part 15 of the FCC Rules. These limits are designed to provide reasonable protection against harmful interference when the equipment is operated in a commercial environment. This equipment generates, uses, and can radiate radio frequency energy and, if not installed and used in accordance with the instruction manual, may cause harmful interference to radio communications. Operation of this equipment in a residential area is likely to cause harmful interference in which case the user will be required to correct the interference at his own expense. This Class A digital apparatus complies with Canadian ICES-003.

Contents

Safety Precautions.....	1
Installation Overview.....	1
Specifications.....	2
Introduction.....	3
Part Number Information.....	4
Parts of the BCPM.....	5
Dimensions.....	6
Data Output.....	8
Blink Codes.....	8
Solid-Core Current Sensor Accuracy.....	9
Installation.....	9
Wiring.....	14
Configuration.....	17
Default DIP Switch Settings.....	18
Communications Setup.....	19
Commissioning.....	20
Recommended Accessories.....	21
Troubleshooting.....	21
China RoHS Compliance Information (EFUP Table).....	22

Safety Precautions

⚠ DANGER

HAZARD OF ELECTRIC SHOCK, EXPLOSION, OR ARC FLASH

- Follow safe electrical work practices. See NFPA 70E in the USA or applicable local codes.
- This equipment must only be installed and serviced by qualified electrical personnel.
- Read, understand, and follow the instructions before installing this product.
- Turn off all power supplying equipment before working on or inside the equipment.
- Always use a properly rated voltage sensing device to confirm power is off.
- **DO NOT DEPEND ON THIS PRODUCT FOR VOLTAGE INDICATION.**
- Only install this product on insulated conductors.
- Install device in an appropriate electrical and fire enclosure per local regulations.
- ESD sensitive equipment. Ground yourself and discharge any static charge before handling this device.

Failure to follow these instructions will result in death or serious injury.

Installation Overview

NOTE: This product is not intended for life or safety applications.

1. Disconnect and lock out power. Use a properly rated voltage sensing device to confirm power is off.
2. Mount the current sensor strips adjacent to breaker terminations.
3. **Verify that the serial numbers on the current sensor strips match the serial numbers on the data acquisition board.**
4. Configure communication and addressing parameters using DIP switches.
5. Mount the data acquisition board in the electrical enclosure.
6. Connect current sensor strip cables to the data acquisition board, observing the 2-strip or 4-strip setup and their orientation (A or B) within the panel
7. Wire RS-485 communications.
8. Connect mains monitoring CTs to the auxiliary inputs on the data acquisition board and connect the CTs onto the mains conductors in the enclosure (optional).
9. Wire control power.
10. Wire voltage taps, if applicable (models BCPMA and BCPMB only).
11. Commission the device for operation. See the "Commissioning" section later in this guide for detailed instructions.

NOTE: For detailed instructions, please see the "Installation" section later in this guide.

Specifications

Table 1: Specifications

Type	Description
Inputs	
Input Voltage	90-277 Vac
Frequency	50/60 Hz
Accuracy	
Power/Energy	IEC 62053-21 Class 1, ANSI C12.1-2008
Voltage	±0.5% of reading 90-277V line-to-neutral
Operation	
Sampling Frequency	2560 Hz
Update Rate	1.8 seconds (both panels)
Outputs	
Type	Modbus™ RTU
Connection	DIP switch-selectable 2-wire or 4-wire, RS-485
Address	DIP switch-selectable address 1 to 247 (in pairs of 2)*
Baud Rate	DIP switch-selectable 9600, 19200, 38400
Parity	DIP switch-selectable NONE, ODD, EVEN
Communication Format	8 data-bits, 1 start-bit, 1 stop-bit
Termination	5-position depluggable connector (TX+ TX- SHIELD TX+/RX+ TX-/RX-)
Mechanical	
Ribbon Cable Support	4 ft. (1.2 m) round cable ships standard; up to 20 ft. (6 m) ribbon cables are available
Environmental	
Operating Temperature Range	0° to 60°C (32° to 122°F) (<95% RH, non-condensing)
Storage Temperature Range	-40° to 70°C (-40° to 158°F)
Altitude of Operation	3000 m
Agency Approvals	UL508, EN61010

* See Configuration section for details

UL listed under standard 508 as an “open type device.”

The BCPM Series must be installed in an appropriate electrical and fire enclosure per local regulations.

Installation category: CAT III

For use in a Pollution Degree 2 or better environment only.

A Pollution Degree 2 environment must control conductive pollution and the possibility of condensation or high humidity. Consideration must be given to the enclosure, the correct use of ventilation, thermal properties of the equipment and the relationship with the environment.

IEC/EN: EN 61010 CE

Always use this product in the manner specified or the protection provided by the product may be impaired.



Introduction

The PowerLogic™ Branch Circuit Power Meter (BCPM) is a device designed to measure the current, voltage, and energy consumption of up to 92 circuits (84 branch circuits, 2 3-phase mains, 2 neutrals) on a single board. It increases the board's current monitoring capability by combining the functions of two boards into one device.

The BCPM consists of a data acquisition board and up to four 21-unit current sensor strips and eight auxiliary inputs. The strips are mounted on each side of the panel board along the termination points of each breaker. The conductor passes through the strip appropriate current sensor before terminating at the breaker. Each strip transmits the current data to the data acquisition board.

Data is transmitted over an RS-485 Modbus protocol. Each data acquisition board requires two addresses, one for each set of two current sensor strips and four auxiliary inputs. Data is updated roughly every two seconds. As a circuit approaches the user-defined threshold, the BCPM activates the alarm indicators.

The BCPM is available in three model types. The BCPMA measures both current and power in the mains and branch circuits. The BCPMB measures power in the mains and current only in the branch circuits. The BCPMC measures current in the mains and branch circuits only.

Figure 1 Branch Circuit Power Meter (BCPM)

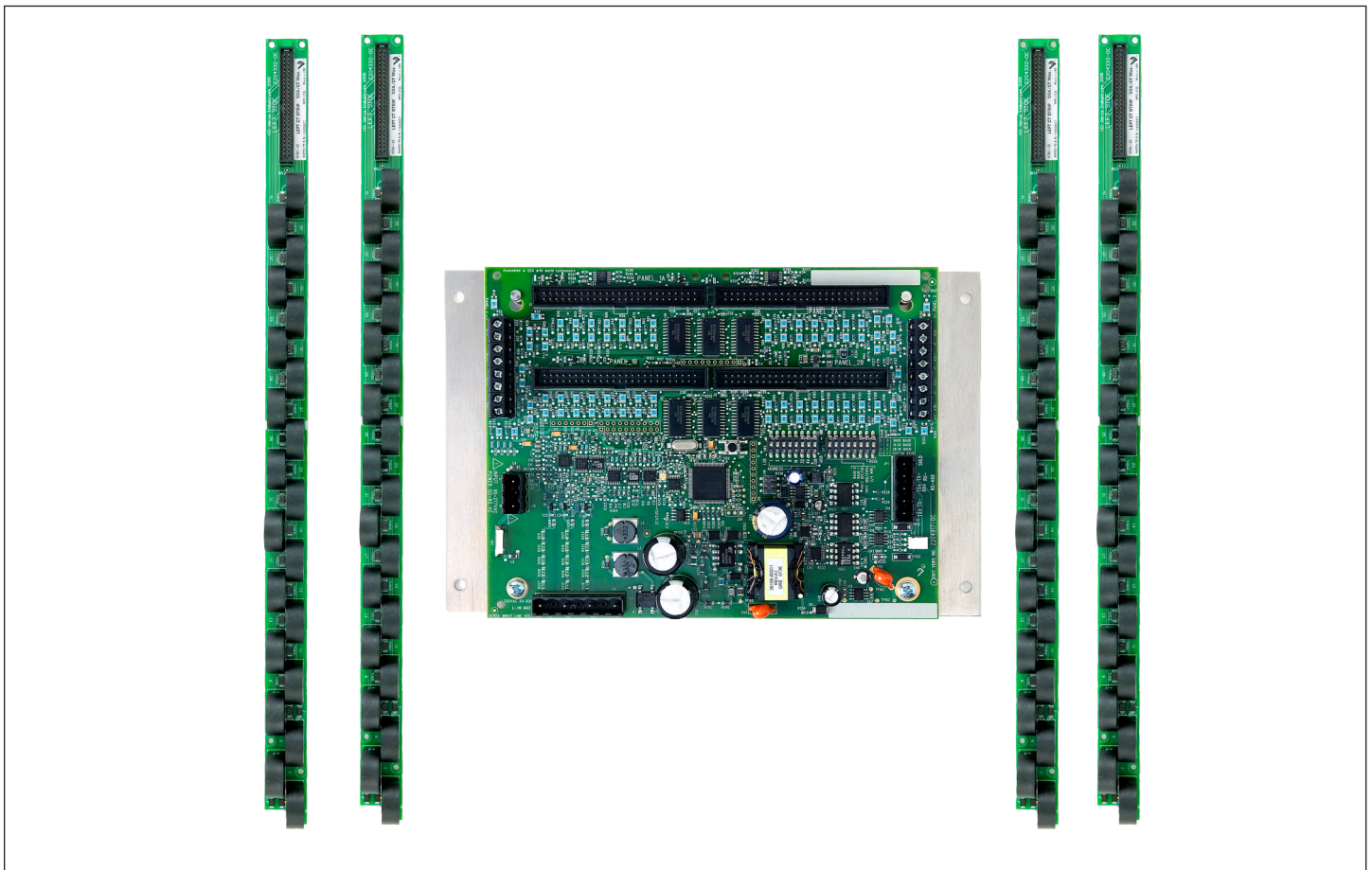

Part Number Information

Part Number	Description
BCPMA084S	BCPM Advanced feature set, 84 solid core 100 A CTs, 19 mm CT spacing
BCPMA184S	BCPM Advanced feature set, 84 solid core 100 A CTs, 26 mm CT spacing
BCPMA042S	BCPM Advanced feature set, 42 solid core 100 A CTs, 19 mm CT spacing
BCPMA142S	BCPM Advanced feature set, 42 solid core 100 A CTs, 26 mm CT spacing
BCPMB084S	BCPM Intermediate feature set, 84 solid core 100 A CTs, 19 mm CT spacing
BCPMA224S	BCPM Advanced feature set, 24 solid core 100 A CTs (2 strips), 18 mm CT spacing
BCPMA236S	BCPM Advanced feature set, 36 solid core 100 A CTs (2 strips), 18 mm CT spacing
BCPMA242S	BCPM Advanced feature set, 42 solid core 100 A CTs (2 strips), 18 mm CT spacing
BCPMA248S	BCPM Advanced feature set, 48 solid core 100 A CTs (4 strips), 18 mm CT spacing
BCPMA272S	BCPM Advanced feature set, 72 solid core 100 A CTs (4 strips), 18 mm CT spacing
BCPMA284S	BCPM Advanced feature set, 84 solid core 100 A CTs (4 strips), 18 mm CT spacing
BCPMB184S	BCPM Intermediate feature set, 84 solid core 100 A CTs, 26 mm CT spacing
BCPMB042S	BCPM Intermediate feature set, 42 solid core 100 A CTs, 19 mm CT spacing
BCPMB142S	BCPM Intermediate feature set, 42 solid core 100 A CTs, 26 mm CT spacing
BCPMC084S	BCPM Basic feature set, 84 solid core 100 A CTs, 19 mm CT spacing
BCPMB224S	BCPM Intermediate feature set, 24 solid core 100 A CTs (2 strips), 18 mm CT spacing
BCPMB236S	BCPM Intermediate feature set, 36 solid core 100 A CTs (2 strips), 18 mm CT spacing
BCPMB242S	BCPM Intermediate feature set, 42 solid core 100 A CTs (2 strips), 18 mm CT spacing
BCPMB248S	BCPM Intermediate feature set, 48 solid core 100 A CTs (4 strips), 18 mm CT spacing
BCPMB272S	BCPM Intermediate feature set, 72 solid core 100 A CTs (4 strips), 18 mm CT spacing
BCPMB284S	BCPM Intermediate feature set, 84 solid core 100 A CTs (4 strips), 18 mm CT spacing
BCPMC184S	BCPM Basic feature set, 84 solid core 100 A CTs, 26 mm CT spacing
BCPMC042S	BCPM Basic feature set, 42 solid core 100 A CTs, 19 mm CT spacing
BCPMC142S	BCPM Basic feature set, 42 solid core 100 A CTs, 26 mm CT spacing
BCPMC224S	BCPM Basic feature set, 24 solid core 100 A CTs (2 strips), 18 mm CT spacing
BCPMC236S	BCPM Basic feature set, 36 solid core 100 A CTs (2 strips), 18 mm CT spacing
BCPMC242S	BCPM Basic feature set, 42 solid core 100 A CTs (2 strips), 18 mm CT spacing
BCPMC248S	BCPM Basic feature set, 48 solid core 100 A CTs (4 strips), 18 mm CT spacing
BCPMC272S	BCPM Basic feature set, 72 solid core 100 A CTs (4 strips), 18 mm CT spacing
BCPMC284S	BCPM Basic feature set, 84 solid core 100 A CTs (4 strips), 18 mm CT spacing

Parts of the BCPM

Figure 2 shows the parts of the BCPM, while Table 2 describes these parts.

Figure 2 BCPM Panel Board Monitoring System

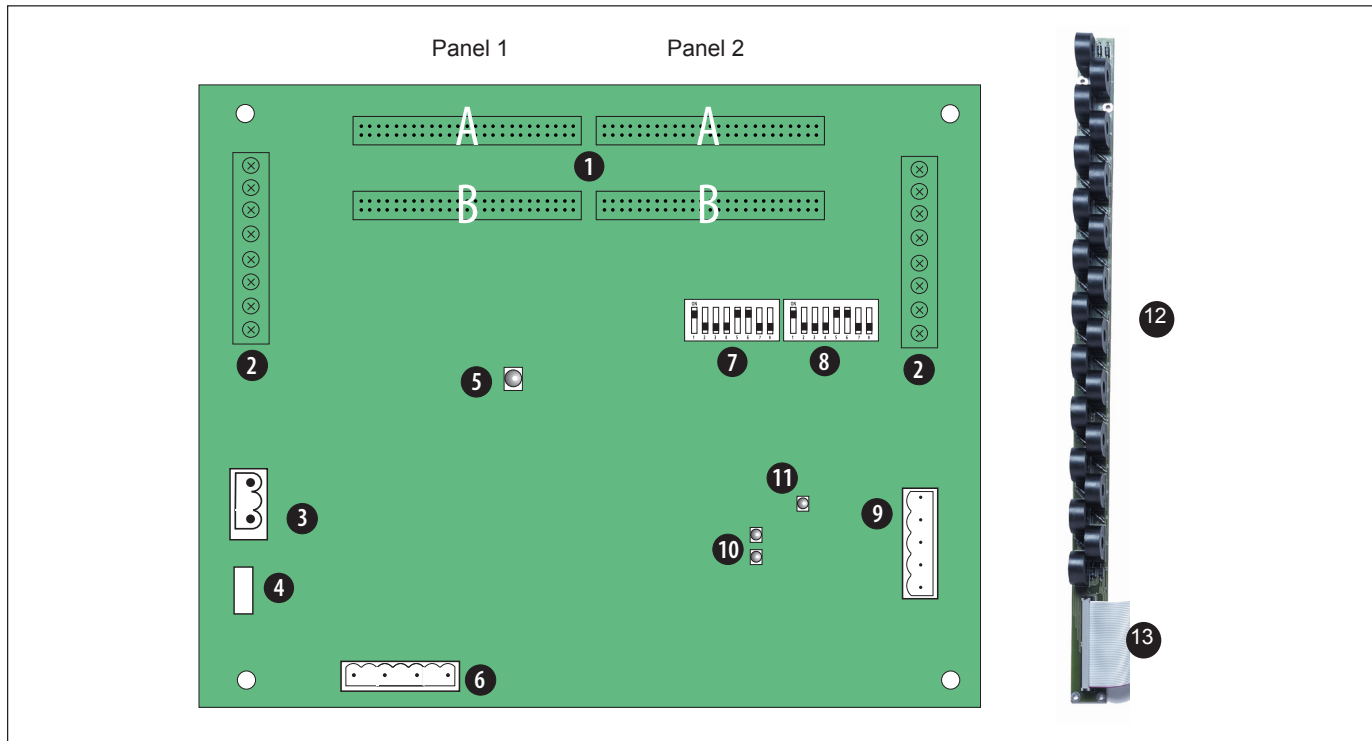

Table 2: Parts Description of the BCPM

Part	Description
1	50-Pin Ribbon Cable Connectors (Data Acquisition Board) 48-inch (1220 mm) ribbon cables are provided for easy snap connection of current sensor strips to this point of the data acquisition board. The two connectors on the left are for Panelboard 1; the two on the right are for Panelboard 2. Note: Connect current sensor strips to the correct ribbon cable connectors for each panel. The top connector is for Strip A, and the bottom connector is for Strip B. Note: Verify that the serial numbers on the current sensor strips match the serial number on the data acquisition board.
2	Auxiliary Inputs These 0.333 Vac inputs are used for monitoring the main breaker or other high amperage source. Inputs on the left are for Panelboard 1; inputs on the right are for Panelboard 2.
3	Control (Mains) Power Connection Easy 2-wire 90-277 Vac 50/60 Hz connection.
4	Control Power Fuse 600 Vac, 500 mA time lag, factory-replaceable.
5	Alive LED Red/green/amber LEDs. See Table 4 for LED blink codes.
6	Voltage Taps 1, 2, or 3 phase plus neutral connections. For voltage sensing and power calculations. Voltage connectors on models BCPMA and BCPMB only.
7	Communications Address DIP Switches Each Modbus® device must have a unique address. Switches are binary weighted. Left-most switch has a value of 1; right-most switch has a value of 128. The 4-strip model uses two addresses.
8	Communications Settings DIP Switch Configures baud rate, parity, 2- or 4-wire communications.
9	RS-485 Connection Used for Modbus® serial communications. The Universal plug accommodates 2- or 4-wire connections.
10	RS-485 LEDs The RX LED (closest to DIP switches) indicates the RS-485 is receiving information; the TX LED indicates transmission of information.
11	Power LED Indicates power to main board
12	Current Sensors Each current sensor is capable of monitoring conductors rated up to a maximum of 100 amps.
13	50 Pin Ribbon Cable Connectors (CT Strips) Connects current signal from the current sensor strip to the main board via the ribbon connectors.

Dimensions

Figure 3 Data Acquisition Board and Mounting Bracket

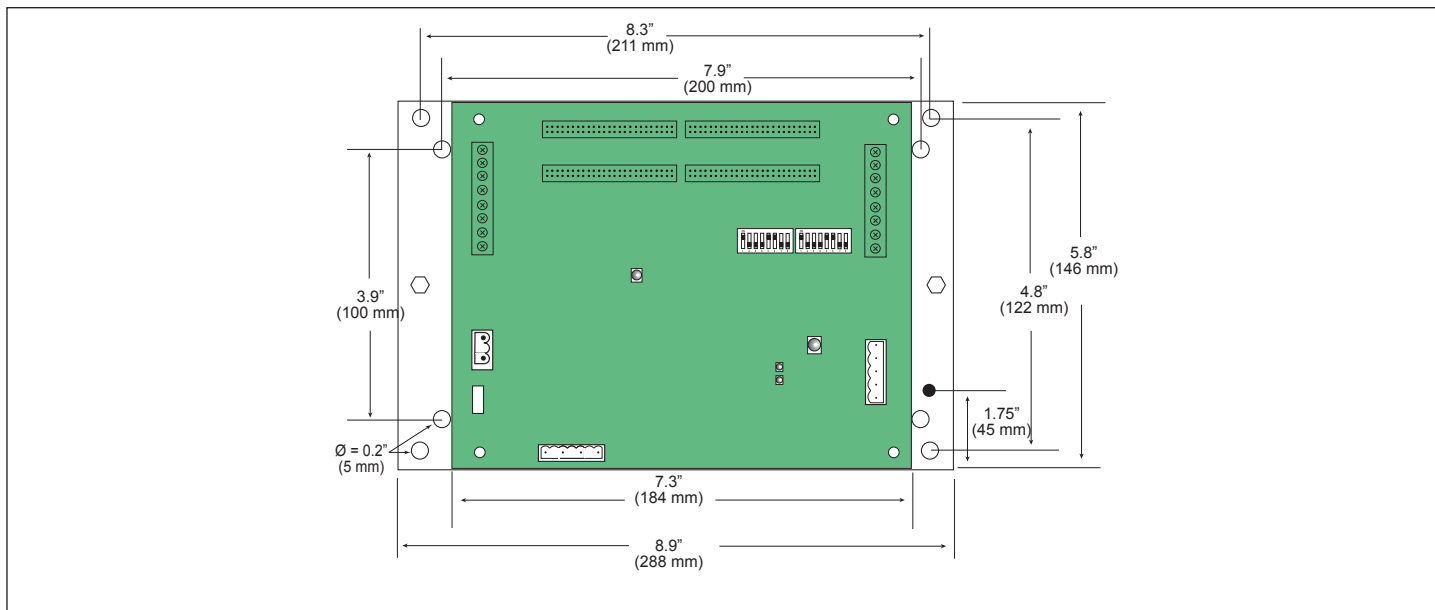
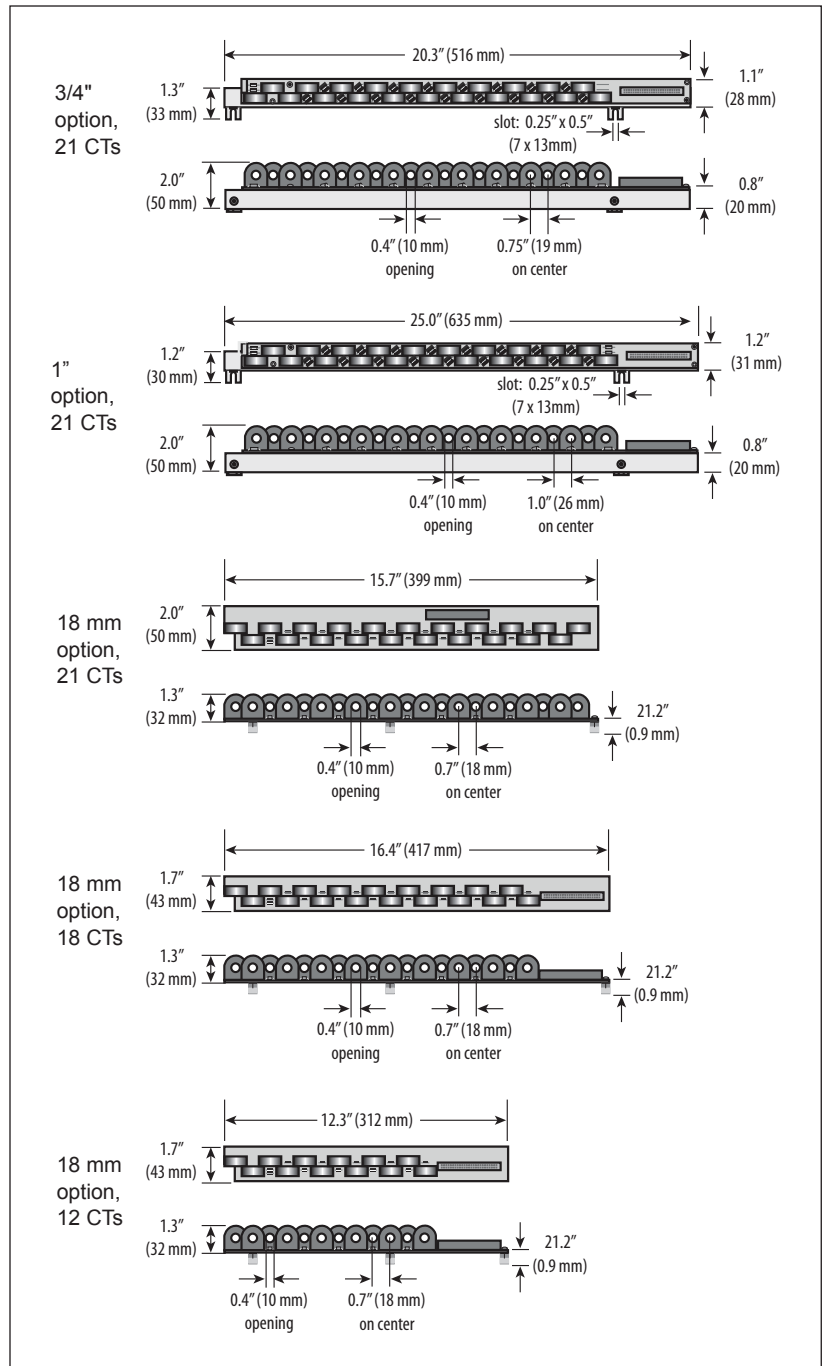

Figure 4 Current Sensor Strips



Data Output

Table 3: Data Output

	BCPMA	BCPMB	BCPMC
Monitoring at Mains			
Current per phase	•	•	•
Max. current per phase	•	•	•
Current demand per phase	•	•	•
Max. current demand per phase	•	•	•
Energy (kWh) per phase	•	•	
kW, Real power per phase	•	•	
Apparent power (kVA)	•	•	
Power Factor, total*	•	•	
Power Factor, per phase	•	•	
Voltage, L-L; avg. of 3 phases	•	•	
Voltage, L-N; avg. of 3 phases	•	•	
Voltage, L-N; per phase	•	•	
Frequency (Phase A)	•	•	
Monitoring at Branch Circuit			
Current	•	•	•
Max. current	•	•	•
Current demand	•	•	•
Max. current demand	•	•	•
Real power (kW)	•		
Real power (kW) demand	•		
Real power (kW) demand max.	•		
Energy (kWh) per circuit	•		
Power factor	•		
Apparent power (kVA)	•		
Modbus Alarms			
Voltage over/under	•	•	
Current over/under	•	•	•

*Based on a 3-phase breaker rotation

Blink Codes

Table 4: LED Blink Codes

Color and Pattern	Status Description
Green, once per second	Normal operation
Amber, once per second	Volts or Amps clipping
Amber, twice per second	Invalid firmware image
Amber, three per second	Incorrect strips or strip order
Red, solid or blink	Diagnostic event detected

Solid Core Current Sensor Accuracy

Table 5: Accuracy

	100A Solid-Core CT
Voltage Rating	300 VAC
Accuracy	±0.5%
Temperature	0° to 60°C
Agency	UL508 recognized, EN61010

Installation

1. Turn off all power to the electrical panel and lock it out. Use a properly rated voltage sensing device to confirm power is off.
2. Install the current sensor strips in the panel. The panel board screws are 16.50" (420 mm) apart. Line up current sensors directly with the breaker terminations (Figure 5).

NOTE: The current sensors accept maximum #2 AWG (0.384" O.D.) wire with THHN insulation. Use this gauge wire or smaller for each circuit.

Figure 5 Installing the current sensor strips in the panel

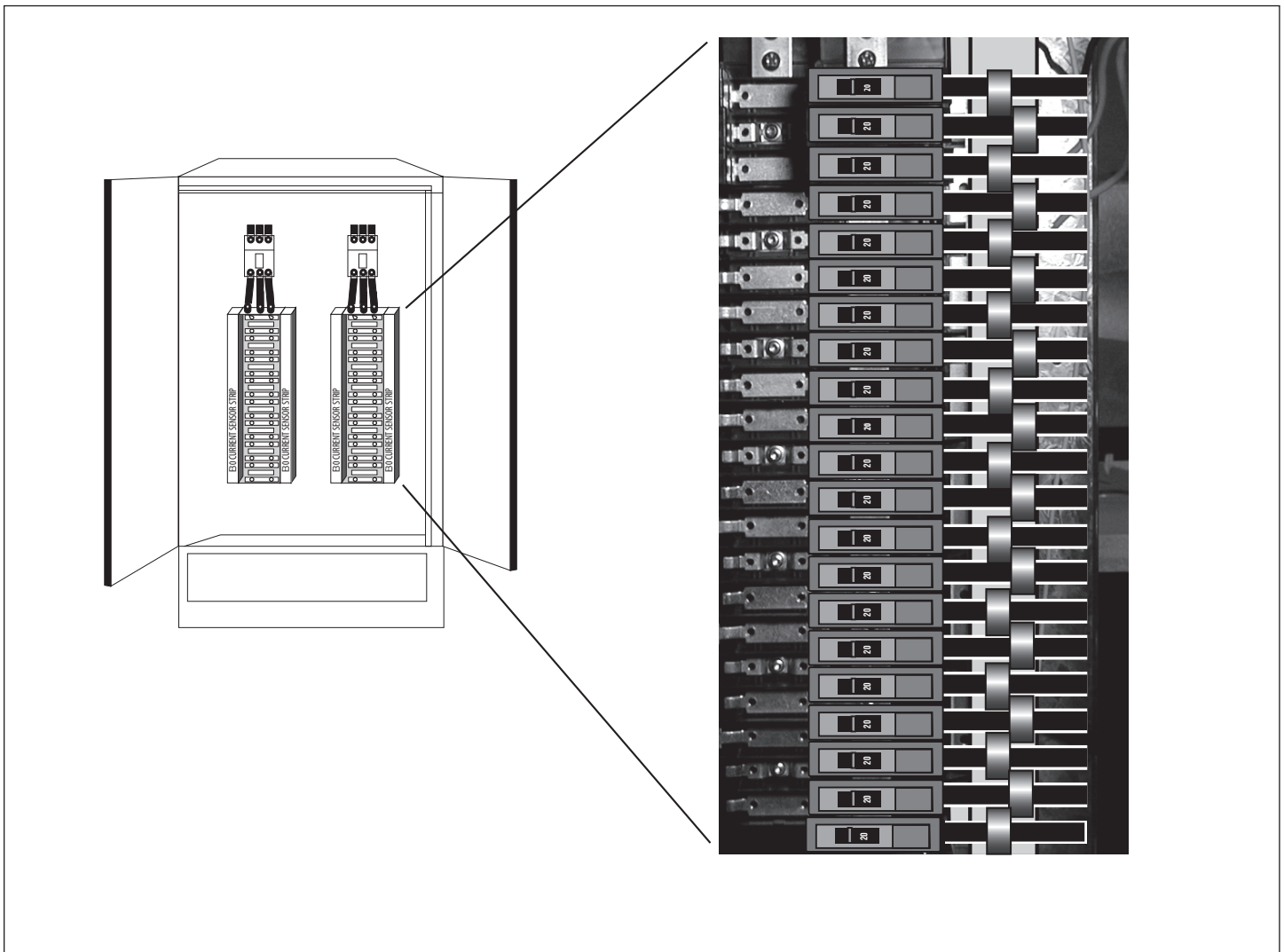

3. Arrange the current sensor strips in one of the four configurations shown in Figure 6. Adjust orientation of the circuit numbers in the field during commissioning by writing to Modbus® Register 6.

Figure 6 Circuit Number Orientation

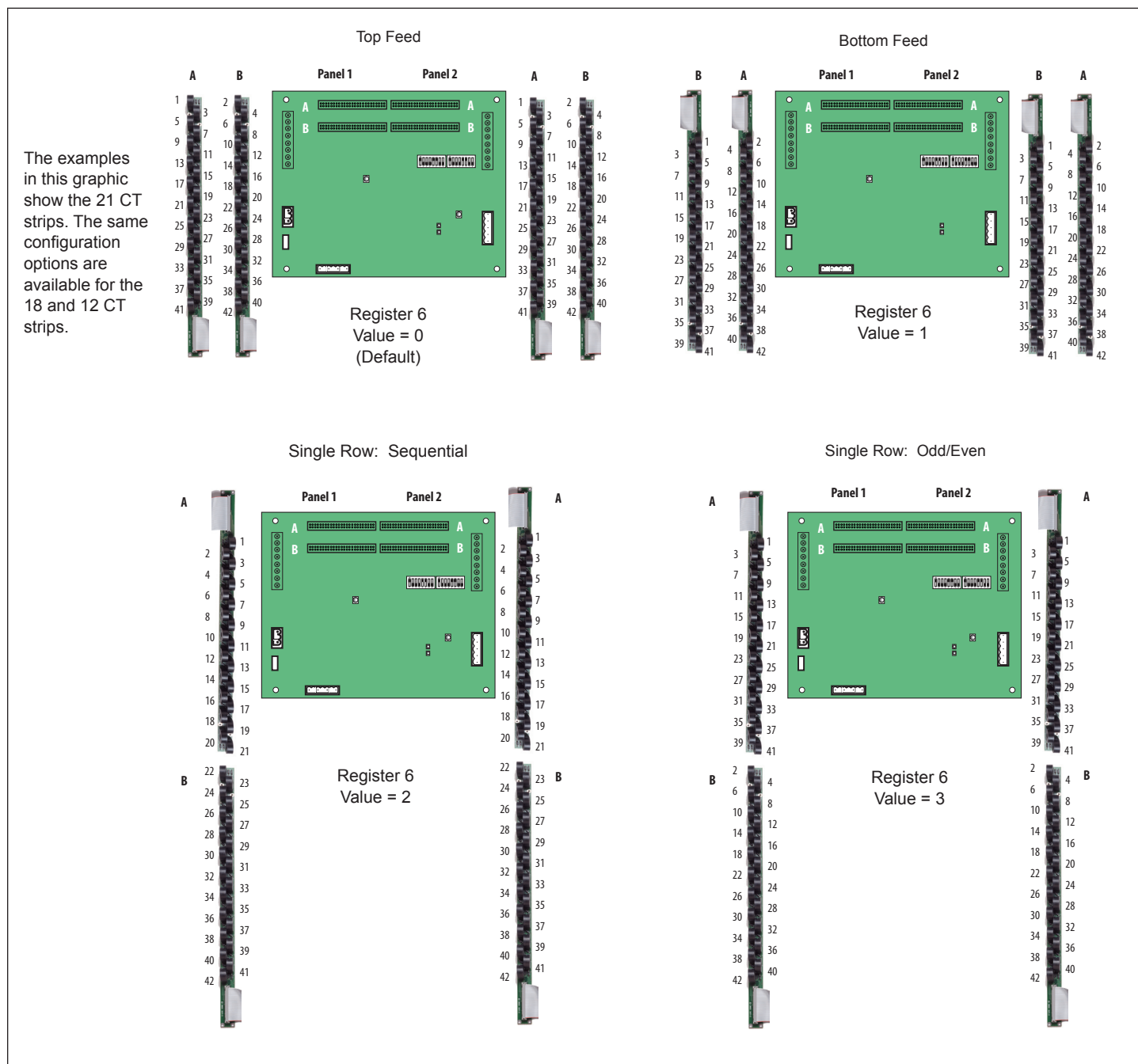

4. Check that the serial numbers printed on the current sensor strip and on the data acquisition board match. **The board and the strip are sold as a calibrated set.**
5. Configure communication and addressing parameters using DIP switches. The BCPM requires two addresses, one for each set of two current sensor strips and four auxiliary inputs. See the “Configuration” section for more information.

6. Install the BCPM data acquisition board mounting bracket in the panel using screws and bolts provided (Figure 7). A grounding connection is located on the mounting bracket, near the lower right corner. Use this stud to ground the bracket when it is mounted on a nonconductive surface.

Figure 7 BCPM Data Acquisition Board

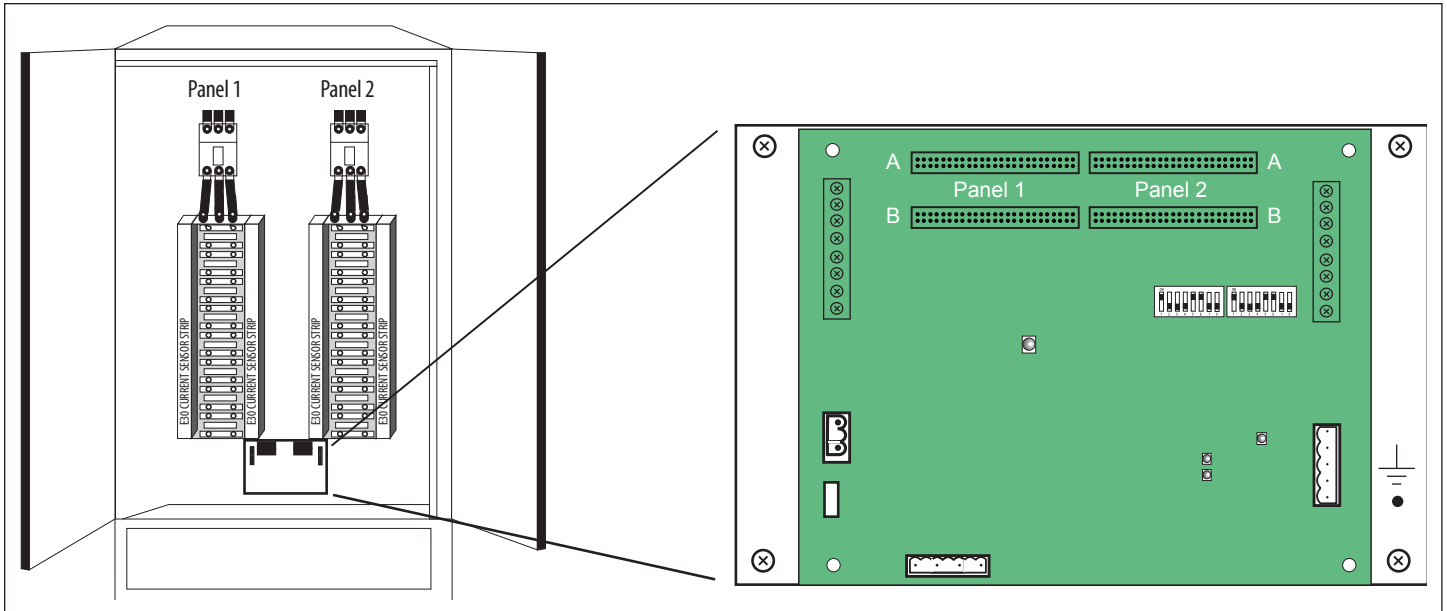

7. Check the labels on the current sensor strip and on the data acquisition board to make sure the serial numbers match. Additionally, the label indicates which connector to use on the data acquisition board (e.g. connect the strip labeled "Panel 1A" to the top left connector on the board; see Figure 8).

NOTE: When the device is powered, if the current sensor strips are installed incorrectly, the Alive LED blinks amber, three times per second. Check the labels and correct the connections.

Figure 8 Check labels to match serial numbers

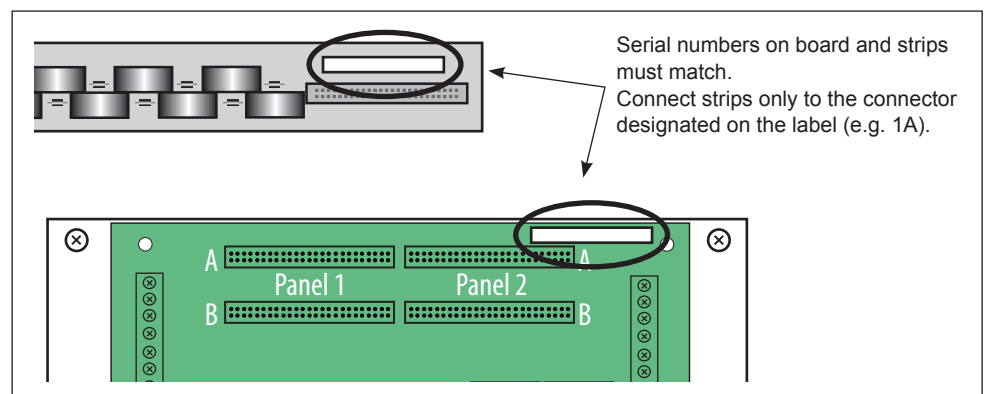

- Connect the current sensor cables to the 50-pin connectors on the main board. Orient the cables so that the red stripe is on the left (Figure 9).

Figure 9 Connectors

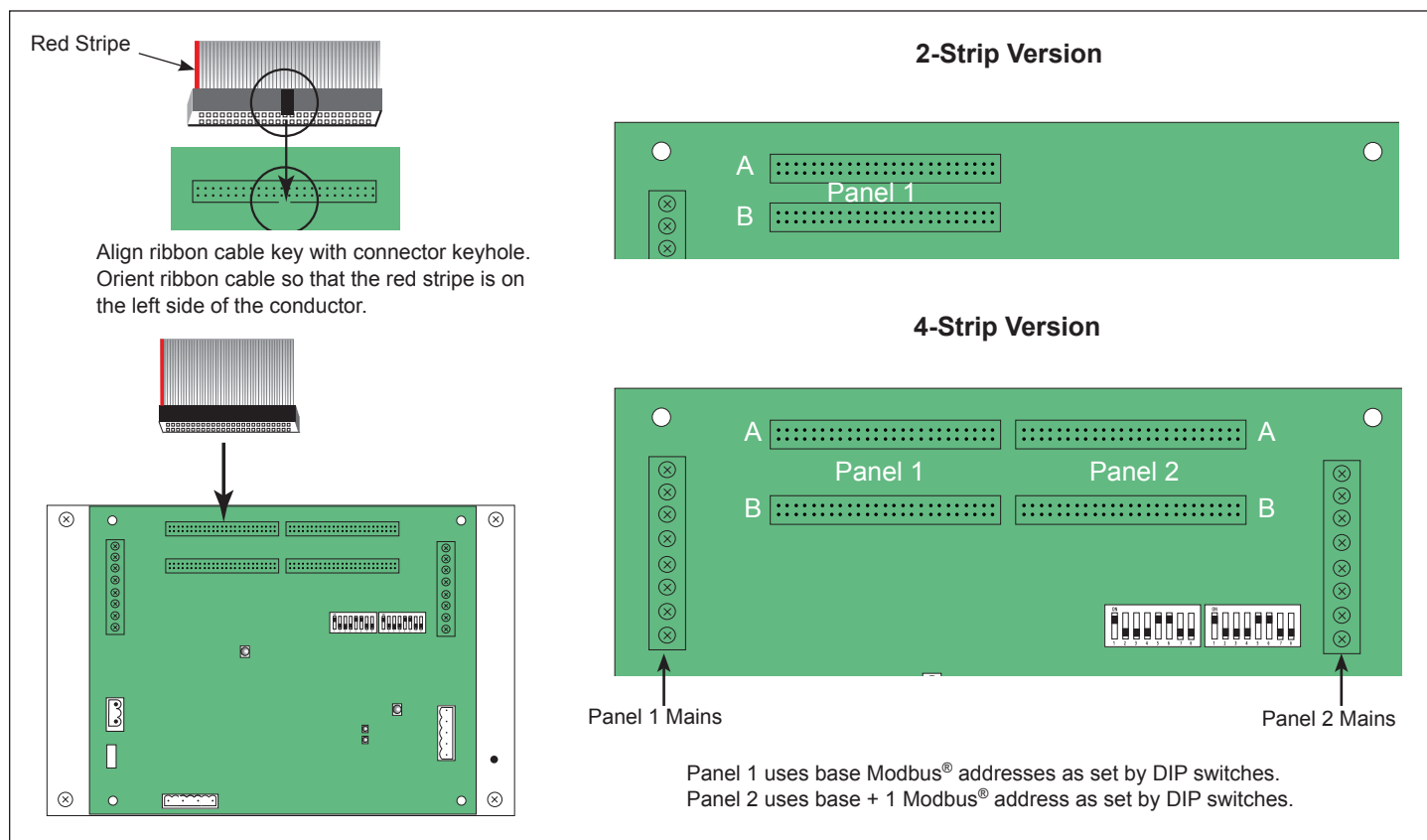

- Wire RS-485 communications. See the diagrams in the “Wiring” section.
- Connect the CTs to the main conductors by snapping CTs around lines, observing local codes regarding bending radius (optional; Figure 10).

Figure 10 Connect CTs to main conductors

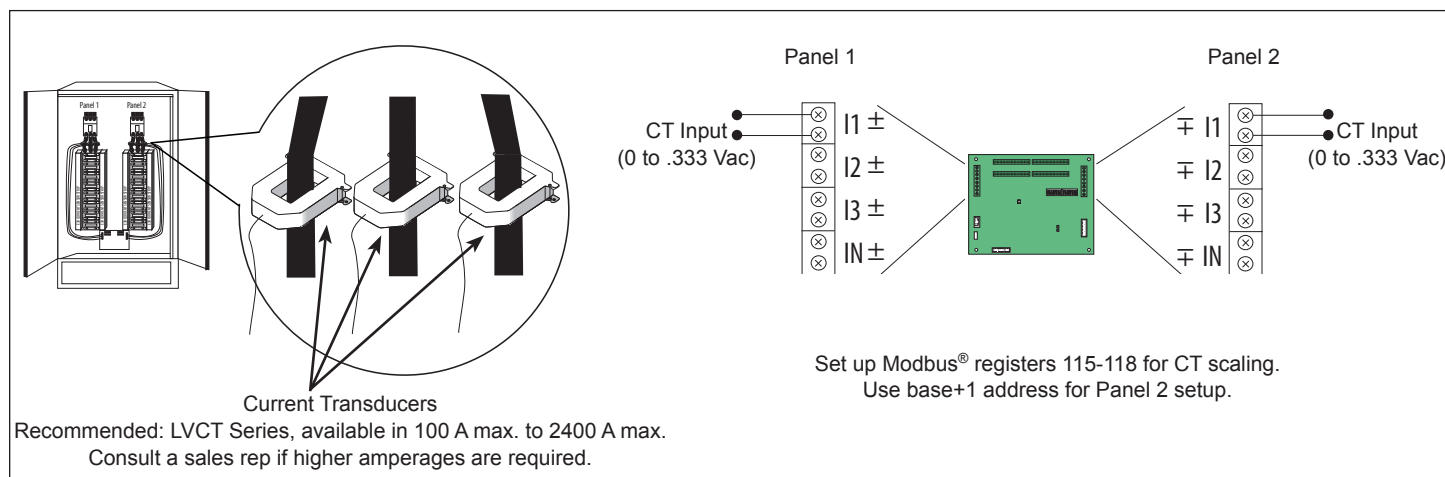

- Connect 2-wire 90-277 Vac power to main power terminals. Observe polarity. For the BCPMA and BCPMB, connect voltage lines to the voltage taps (Figure 11). Voltage lines must be equipped with fuses.

Figure 11 Connecting power to power terminals

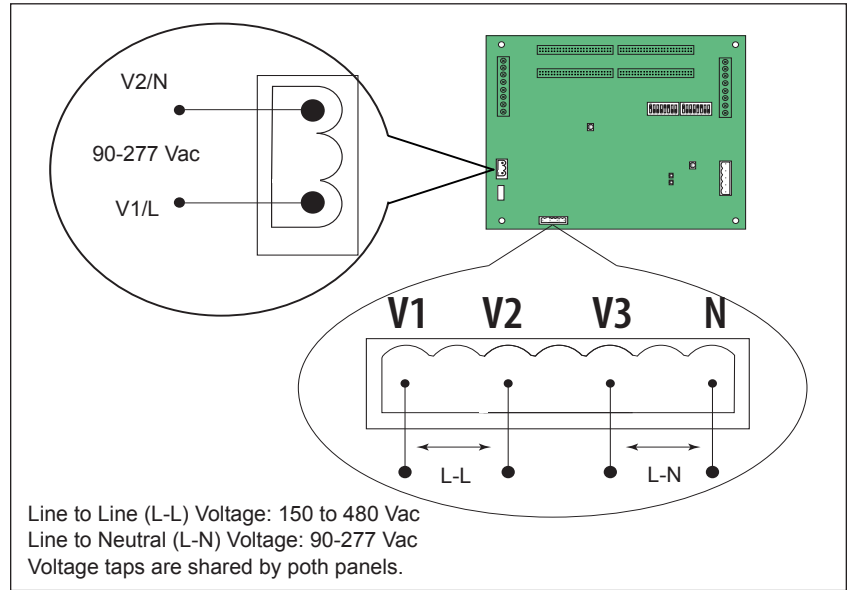

Wiring

⚠ DANGER

HAZARD OF ELECTRIC SHOCK, EXPLOSION, OR ARC FLASH

- Apply appropriate personal protective equipment (PPE) and follow safe electrical work practices. See NFPA 70E in the USA or applicable local codes.
- This equipment must only be installed and serviced by qualified electrical personnel.
- Turn off all power supplying equipment before working on or inside the equipment.
- Always use a properly rated voltage sensing device to confirm power is off.
- Read, understand, and follow the instructions before installing this product.

Failure to follow these instructions will result in death or serious injury.

NOTE: If BCPM products are installed in circuits with higher voltage ratings, keep the circuits segregated per UL508A Sec. 17.5.

NOTE: 480Y/277 Vac connected (center grounded) power systems operate within the 300 Vac line-to-neutral voltage rating of the BCPM Series, and the operational voltage limit (single-phase connection) as the line-to-neutral voltage is 277 Vac in such power systems. Corner-grounded delta 480 Vac systems would not qualify, as the actual line-to-earth voltage is 480 Vac on each leg, exceeding the BCPM ratings.

NOTE: BCPM internal circuitry (cables and CTs) are not circuits as defined by UL508A, as they do not extend beyond the BCPM itself without further fire isolation.

1. Turn off all power to this equipment and the equipment it is installed in before installing wires. Use a properly rated voltage sensing device to confirm power is off.
2. Connect 2-wire or 4-wire Modbus® RS-485 daisy chain network. See Figures 12 and 13.

Figure 12 Communications Connector

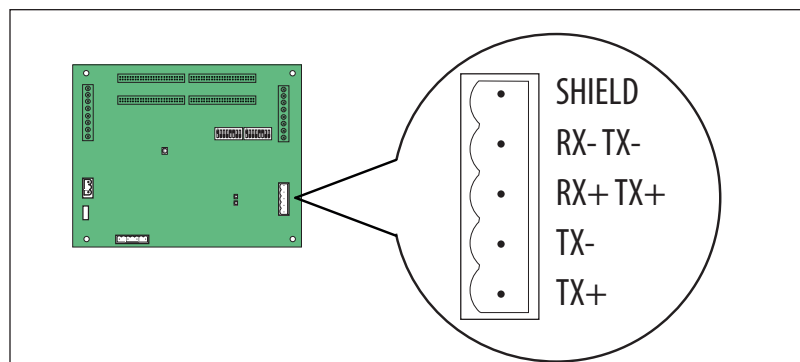
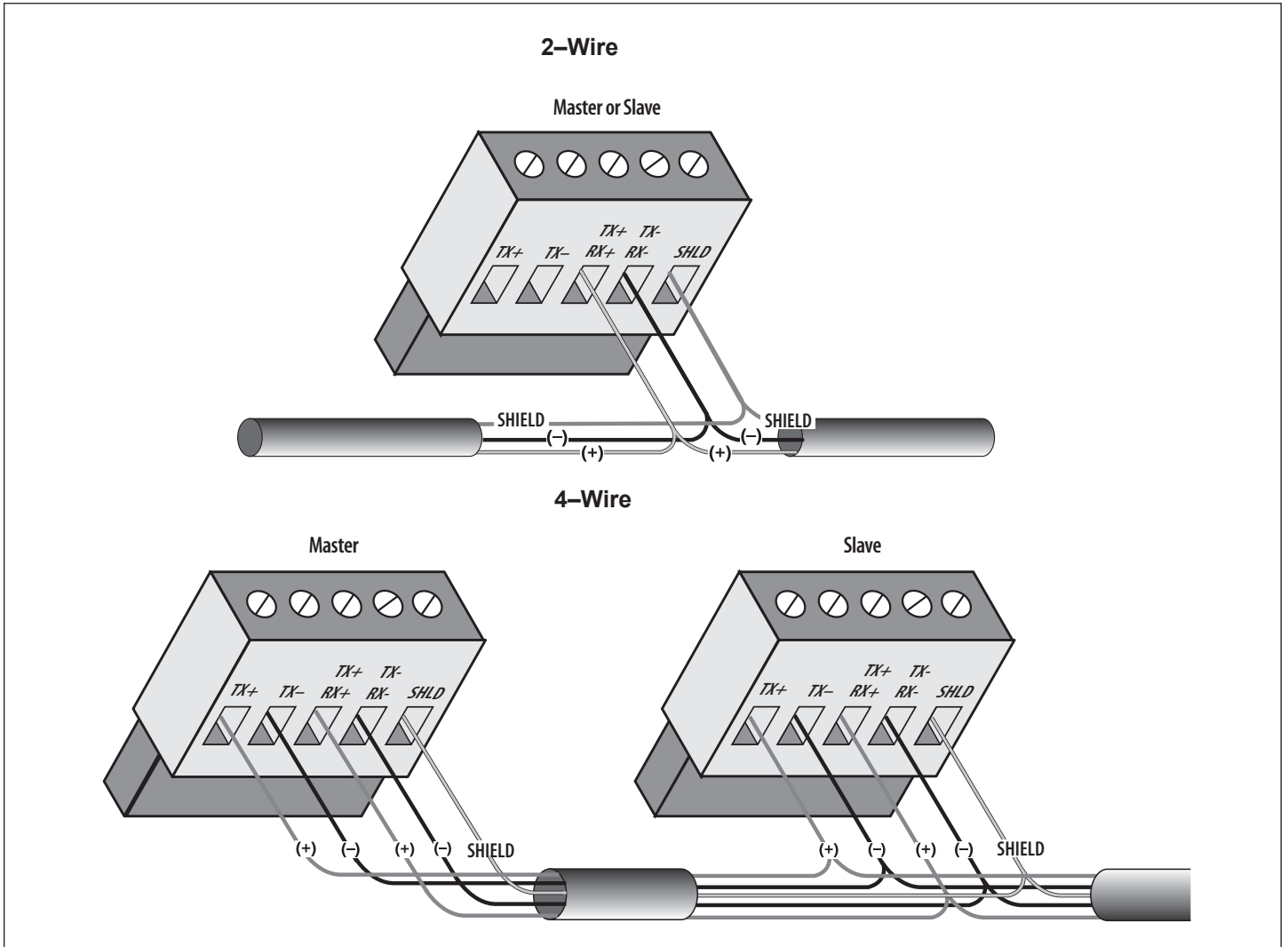
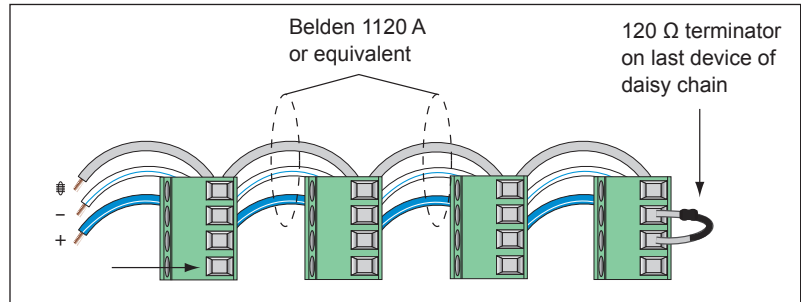

Figure 13 2-wire and 4-wire communications wiring



3. Mechanically secure the RS-485 cable where it enters the electrical panel.
4. Connect all RS-485 devices together in a daisy-chain fashion, and properly terminate the chain (Figure 14).

Figure 14 Properly terminated daisy chain network



5. Shield the RS-485 cable using twisted pair wire such as Belden 1120A. Use cable that is voltage rated for the installation.
6. When tightening terminals, apply the correct torque: 0.5 to 0.6 N·m (0.37 to 0.44 ft·lb) for connectors on the data acquisition board, 0.22 to 0.26 N·m (0.16 to 0.19 ft·lb) for the connectors on the adapter boards (Figure 15).

Figure 15 Torque requirements

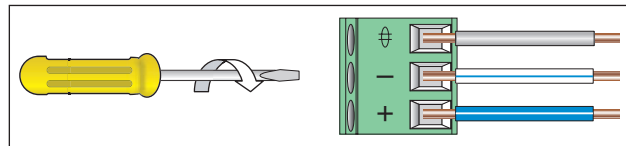

NOTE: After wiring the RS-485 cable, remove all scraps of wire or foil shield from the electrical panel before closing the enclosure.

7. Use ION Setup to set up breaker size, demand interval, and alarm levels. See Appendix A later in this document for more information. ION Setup is available online at <http://www.powerlogic.com>.

Configuration

1. Communications Configuration: Communications parameters for the BCPM are field selectable for your convenience. Please see the Product Diagram section for selector location. The following parameters are configurable:

- Baud Rate: 9600, 19200, 38400
- Parity On or Off
- Parity: Odd or Even
- Wiring: 2 or 4

Figure 16 Switch settings

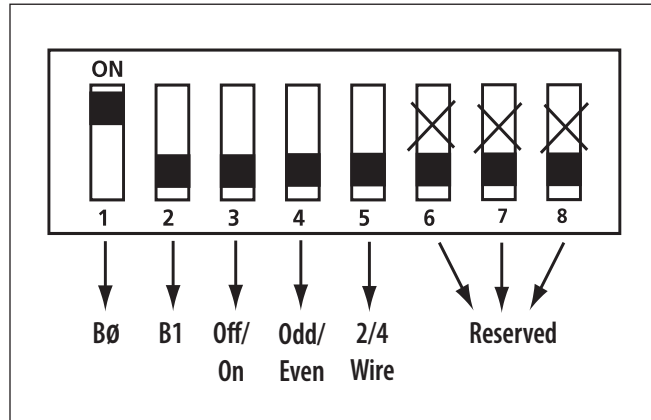
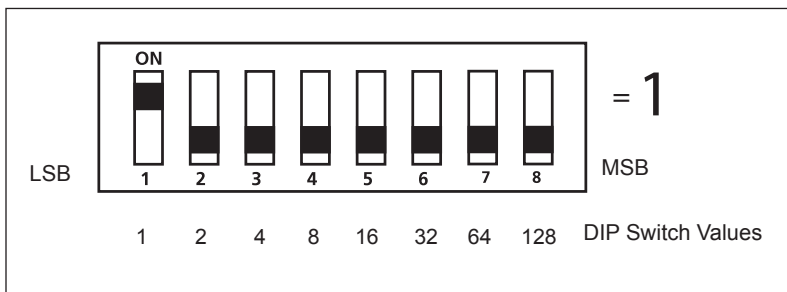

Table 6: 2-wire 19200 Baud No Parity (Default Only)

1	2	3	4	5	6	7	8	
off	off				X	X	X	9600
on	off				X	X	X	19200
off	on				X	X	X	38400
on	on				X	X	X	Custom
		off	off		X	X	X	No Parity
		on	off		X	X	X	Odd Parity
		off	on		X	X	X	No Parity
		on	on		X	X	X	Even Parity
				on	X	X	X	4-wire RS-485
				off	X	X	X	2-wire RS-485

- Each Modbus® device on a single network must have a unique address. Set the switch block to assign a unique address before the device is connected to the Modbus® RS-485 network. If an address is selected that conflicts with another device, neither device will be able to communicate.
- The BCPM uses two logical addresses. Panel 1 uses the base address as set on the DIP switches, and Panel 2 uses this base address + 1. The BCPM can be addressed as any whole number between and including 1-247. Each unit is equipped with a set of eight DIP switches for addressing (Figure 17).

Figure 17 Default switch settings



- To determine an address, add the values of any switch that is on (Figure 18).

Figure 18 Modbus® address DIP switch values



- Switch number 4 has an ON Value of 8 and switch number 6 has an ON Value of 32. (8 + 32 = 40). Therefore, the address for Panel 1 is 40, and the address for Panel 2 is 41.
- See the Communications Setup section for a pictorial listing of the first 63 switch positions.

Default DIP Switch Settings

The BCPM includes two DIP switches, as shown below. Switches are shown in their default positions.

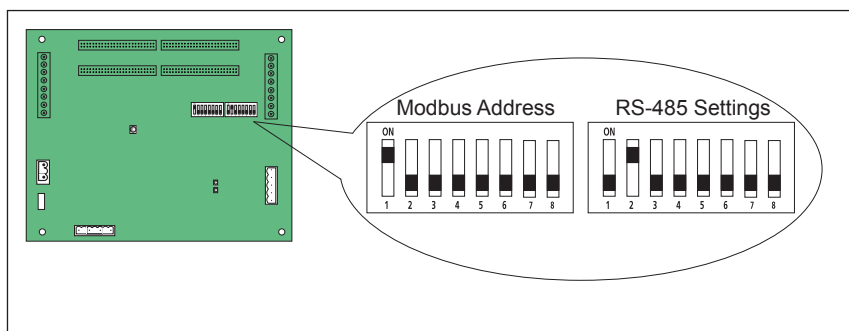

Communications Setup

Figure 19 Address selection switches from 1 to 63

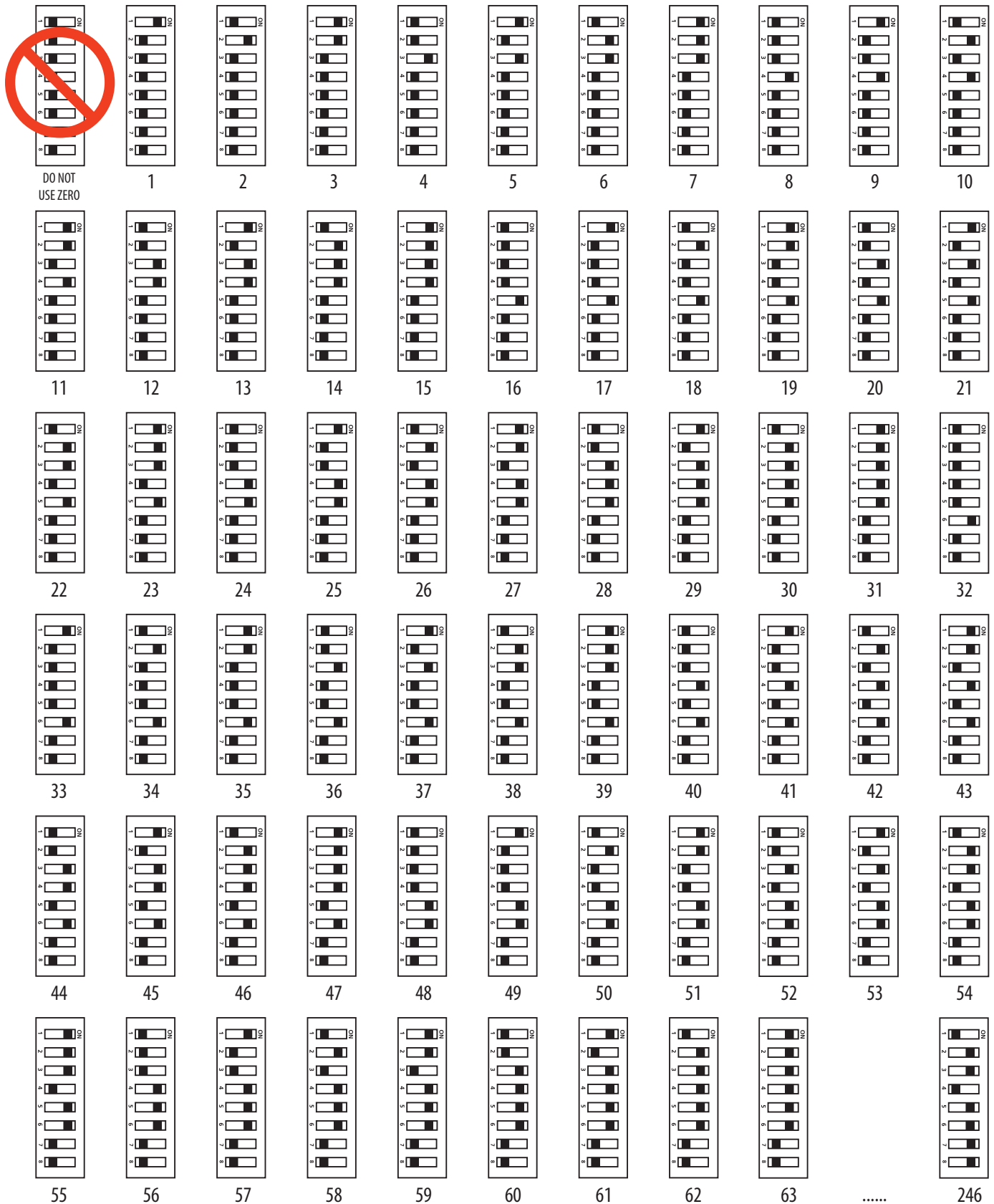

Commissioning

Use ION Setup to configure the BCPMSC. ION Setup is a meter configuration software you can download from www.powerlogic.com

NOTE: Install the latest build in order to get the most up-to-date information, feature and device support for ION Setup.

To learn how to add and configure sites and meters, refer to the ION Setup online help by clicking the Help button or pressing F1 on your keyboard.

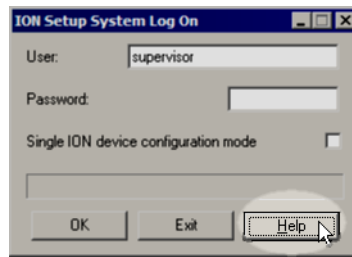

Click the Branch Circuit Power Meter topic for details on configuring the device.

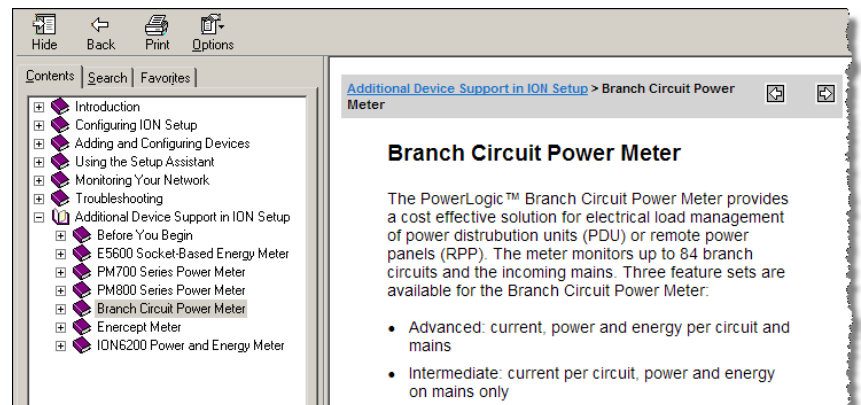

Recommended Accessories

Table 7: Recommended Accessories

Part Number	Description
CBL008	Flat ribbon cable, 50 x 28 AWG, 1.5 ft. (0.45 m)
CBL016	Flat ribbon cable, 50 x 28 AWG, 4 ft. (1.2 m)
CBL017	Flat ribbon cable, 50 x 28 AWG, 5 ft. (1.5 m)
CBL018	Flat ribbon cable, 50 x 28 AWG, 6 ft. (1.8 m)
CBL019	Flat ribbon cable, 50 x 28 AWG, 8 ft. (2.4 m)
CBL020	Flat ribbon cable, 50 x 28 AWG, 10 ft. (3.0 m)
CBL021	Flat ribbon cable, 50 x 28 AWG, 20 ft. (6.1 m)
CBL022	Round ribbon cable, 50 x 28 AWG, 4 ft. (1.2 m)
CBL023	Round ribbon cable, 50 x 28 AWG, 10 ft. (3.0 m)
CBL024	Round ribbon cable, 50 x 28 AWG, 20 ft. (6.1 m)
CBL025	Flat ribbon cable, 50 x 28 AWG, 2 m
CBL026	Flat ribbon cable, 50 x 28 AWG, 4 m
CBL027	Flat ribbon cable, 50 x 28 AWG, 6 m
CBL031	Round ribbon cable, 50 x 28 AWG, 1.5 ft. (0.45 m)
CBL032	Round ribbon cable, 50 x 28 AWG, 2.5 ft. (0.76 m)
BCPMCOVERS	Main circuit board cover, clear, Schneider brand
BCPMREPAIR	CT repair kit
SMD/SMDOPN	Net Display

Troubleshooting

Table 8: Troubleshooting guide

Problem	Solution
Product is not communicating over Modbus daisy chain	<ul style="list-style-type: none"> • Check the unit Modbus address to ensure that each device on the daisy chain has a unique address. • Check Parity. • Check the communications wiring. • Check that the daisy chain is properly terminated.
RX LED is solid	<ul style="list-style-type: none"> • Check for reversed polarity on Modbus comms. • Check for sufficient biasing on the Modbus bus. Modbus physical specification calls for 450-650 Ω biasing. This is usually provided by the master.
The main board has a fast flashing amber light	<ul style="list-style-type: none"> • Check that the 1A and 1B CT strips are connected to the left top and left bottom ribbon cable connections; 2A and 2B must be connected to the right top and right bottom ribbon cable connections (see illustrations in the product installation guide). • Verify ribbon cable connectors are inserted in the correct orientation. • If cables are correct, reset main board to re-initialize product. • Verify serial number on strips matches serial number on main board.
The main board has a slow flashing amber light	<ul style="list-style-type: none"> • One or more channels is clipping. This can be caused by a signal greater than 100 A or 277 V L-N, or by a signal with high THD near the gain stage switching points (1.5 A and 10 A).
The main board has a flashing green light	<ul style="list-style-type: none"> • Everything is wired properly and the main board has power.
The main board is a flashing or solid red light	<ul style="list-style-type: none"> • Light may be red briefly while device powers up. • If light is red for more the 60 sec. device has encountered a diagnostic event. Contact technical support.
Power factor reading is not as expected	<ul style="list-style-type: none"> • Verify voltage taps are connected in appropriate phase rotation. • Verify strip configuration register matches actual strip installation. • Verify phase rotation of breakers (firmware rev. 1.012 or higher allows for custom rotation if needed).
Current reading is not as expected, or reading is on different CT number than expected	<ul style="list-style-type: none"> • Verify strip configuration register matches actual strip installation. • Verify ribbon cable is fully seated and in the correct orientation.
Current is reading zero, even when small currents are still flowing through circuit	<ul style="list-style-type: none"> • The product cuts off at 50 mA, and will set the reporting register to 0 mA for currents near or below this range.

China RoHS Compliance Information

Table 9: EFUP Table

部件名称	产品中有毒有害物质或元素的名称及含量Substances					
	铅 (Pb)	汞 (Hg)	镉 (Cd)	六价铬 (Cr(VI))	多溴联苯 (PBB)	多溴二苯醚 (PBDE)
电子线路板	X	0	0	0	0	0
0 = 表示该有毒有害物质在该部件所有均质材料中的含量均在 SJ/T11363-2006 标准规定的限量要求以下。 X = 表示该有毒有害物质至少在该部件的某一均质材料中的含量超出SJ/T11363-2006标准规定的限量要求。						
Z000057-0A						

Schneider Electric
Power Monitoring and Control
295 Tech Park Dr. Suite 100
La Vergne TN, 37086
1-888-778-2733
www.powerlogic.com

Getting technical support:
Contact your local Schneider Electric
sales representative for assistance or go
to the www.powerlogic.com website.

PowerLogic is a trademark or registered trademark of Schneider Electric in the USA, France and other countries.

Electrical equipment should be installed, operated, serviced, and maintained only by qualified personnel. No responsibility is assumed by Schneider Electric for any consequences arising out of the use of this material.

Z205396-0H © 2013 Schneider Electric All Rights Reserved.