

<p>PLEASE NOTE Electrical equipment should be installed, operated, serviced, and maintained only by qualified personnel. No responsibility is assumed by Schneider Electric for any consequences arising out of the use of this material.</p>	<p>REMARQUE IMPORTANTE L'installation, l'utilisation, la réparation et la maintenance des équipements électriques doivent être assurés uniquement par du personnel qualifié. Schneider Electric décline toute responsabilité quant aux conséquences de l'utilisation de ce matériel.</p>	<p>TENGA EN CUENTA La instalación, manejo, puesta en servicio y mantenimiento de equipos eléctricos deberán ser realizados sólo por personal cualificado. Schneider Electric no se hace responsable de ninguna de las consecuencias del uso de este material.</p>	<p>BITTE BEACHTEN Elektrische Geräte dürfen nur von Fachpersonal installiert, betrieben, bedient und gewartet werden. Schneider Electric haftet nicht für Schäden, die durch die Verwendung dieses Materials entstehen.</p>
<p>NOTA Manutenzione, riparazione, installazione e uso delle apparecchiature elettriche si devono affidare solo a personale qualificato. Schneider Electric non si assume alcuna responsabilità per qualsiasi conseguenza derivante dall'uso di questo materiale.</p>	<p>NOTA A instalação, utilização e manutenção do equipamento eléctrico devem ser efectuadas exclusivamente por pessoal qualificado. A Schneider Electric não assume qualquer responsabilidade pelas consequências resultantes da utilização deste material.</p>	<p>请注意 电气设备的安装、操作、维修和维护工作仅限于合格人员执行。 Schneider Electric 不承担由于使用本资料所引起的任何后果。</p>	<p>ОБРАТИТЕ ВНИМАНИЕ Установка, эксплуатация, ремонт и обслуживание электрического оборудования может выполняться только квалифицированными электриками. Компания Schneider Electric не несет никакой ответственности за любые возможные последствия использования данной документации.</p>

⚠ ⚠ DANGER / DANGER / PELIGRO / GEFAHR / PERICOLO / PERIGO / 危險 / ОПАСНО

<p>HAZARD OF ELECTRIC SHOCK, EXPLOSION, OR ARC FLASH <ul style="list-style-type: none"> Disconnect all power before servicing equipment. Close securely the enclosure before reapplying power. Failure to follow these instructions will result in death or serious injury.</p>	<p>RISQUE D'ÉLECTROCUTION, D'EXPLOSION OU D'ECLAIR D'ARC ELECTRIQU <ul style="list-style-type: none"> Coupez toutes les alimentations avant de travailler sur cet appareil. Fermez correctement le coffret avant de remettre l'appareil sous tension. Le non-respect de ces instructions provoquera la mort ou des blessures graves.</p>	<p>PELIGRO DE DESCARGA ELÉCTRICA, EXPLOSIÓN O ARCO ELECTRICO <ul style="list-style-type: none"> Desconecte todas las alimentaciones antes de manipular el producto. Cierre la carcasa correctamente antes de volver a suministrar corriente. Si no se siguen estas instrucciones provocará lesiones graves o incluso la muerte.</p>	<p>GEFAHR VON ELEKTRISCHEM SCHLAG, EXPLOSION ODER LICHTBOGEN <ul style="list-style-type: none"> Vor dem Arbeiten am Gerät alle Spannungsversorgungen abschalten. Vor dem Wiedereinschalten der Spannungsversorgung das Gehäuse sicher verschließen. Die Nichtbeachtung dieser Anweisungen führt zu Tod oder schwerer Körperverletzung.</p>
<p>RISCHIO DI SCARICA ELETTRICA , ESPLOSIONE O ARCO ELETTRICO <ul style="list-style-type: none"> Scollegare l'apparecchio da tutti i circuiti di alimentazione prima di qualsiasi intervento. Prima di rimettere l'apparecchio sotto tensione chiudere correttamente la scatola. Il mancato rispetto di queste istruzioni provocherà morte o gravi infortuni.</p>	<p>RISCO DE ELECTROCUSSÃO, DE EXPLOÇÃO, OU DE ARCO ELÉCTRICO <ul style="list-style-type: none"> Desconecte todas as alimentações antes de manipular o produto. Feche correctamente o invólucro antes de voltar a aplicar potência. A não observância destas instruções resultará em morte, ou ferimentos graves.</p>	<p>电击、爆炸或电弧闪光危险 <ul style="list-style-type: none"> 在此电力设备上工作时,请先切断所有电源 请先关严外盖,再加电。 不遵循上述说明将导致人员伤亡。</p>	<p>Опасность поражением электрическим током, опасность взрыва или вспышки дуги. <ul style="list-style-type: none"> Перед обслуживанием или ремонтом убедитесь, что питание отключено. Перед подачей питания надежно закройте корпус. Несоблюдение этих инструкций приведет к смерти или серьезной травме.</p>

<p>The product's manufacture date is coded as PP-YY-WW, where: <ul style="list-style-type: none"> PP: plant code YY: year of manufacture WW: week of manufacture Eg: 2F1429 means the product manufactured at plant 2F on week 29 2014.</p>	<p>La date de fabrication du produit est codée sous la forme PP-YY-WW, où: <ul style="list-style-type: none"> PP: code de l'usine YY: année de fabrication WW: semaine de fabrication Ex: 2F1429 signifie que le produit a été fabriqué à l'usine 2F la semaine 29 de 2014.</p>	<p>La fecha fabricación del producto está codificada como PP-YY-WW, donde: <ul style="list-style-type: none"> PP: código de planta YY: año de fabricación WW: semana de fabricación Por Ej: 2F1429 significa que el producto ha sido fabricado en la planta 2F, la semana 29 del año 2014.</p>	<p>Das Herstellungsdatum des Produkts weist folgendes Format auf: PP-YY-WW. Hierbei gilt Folgendes: <ul style="list-style-type: none"> PP: Code der Produktionsstätte YY: Herstellungsjahr WW: Herstellungswoche Z. B.: 2F1429 kennzeichnet ein Produkt, das in der Produktionsanlage 2F in der Woche 29 des Jahres 2014 hergestellt wurde.</p>
<p>La data di costruzione del prodotto è codificata come segue PP-YY-WW, dove: <ul style="list-style-type: none"> PP: codice stabilimento YY: anno di costruzione WW: settimana di fabbricazione Ad es.: Il codice 2F1429 indica che il prodotto è stato fabbricato presso lo stabilimento 2F nella settimana 29 del 2014.</p>	<p>A data de fabrico do produto está codificada como PP-YY-WW, sendo que: <ul style="list-style-type: none"> PP: código de fábrica YY: ano do fabrico WW: semana de fabrico Ex: 2F1429 significa que o produto foi criado na fábrica 2F na semana 29 de 2014.</p>	<p>产品制造日期编码为 PP-YY-WW, 其中: <ul style="list-style-type: none"> PP: 工厂代码 YY: 制造年份 WW: 第几周制造 例如: 2F1429 表示该产品于 2014 年第 29 周在工厂 2F 制造。</p>	<p>Дата производства продукта указана в виде кода PP-YY-WW, где: <ul style="list-style-type: none"> PP: код завода; YY: год производства; WW: неделя производства Пример: 2F1429 означает, что продукт произведен на заводе 2F на 29-й неделе 2014 года.</p>

	mm ²	mm	in	AWG (60/75°C)	N.m	lb-in.
V0. V1 V2 VZ0. VZ1 VZ2 VZ11 VZ14	1x2,5...6 2x2,5...4	1x2,5...10 2x2,5...4	10,5 0,41	14...8	2,1	18,3
VN. VZN. VZN11 VZN14	1x4 2x1...2,5		7 0,28	14...12	0,73	6,4
VZ7 VZ20	2x1...2,5		8 0,31	14...12	0,73	6,4
VZN05 VZN06	1x4 2x1...2,5		7 0,28	14...12	0,73	6,4

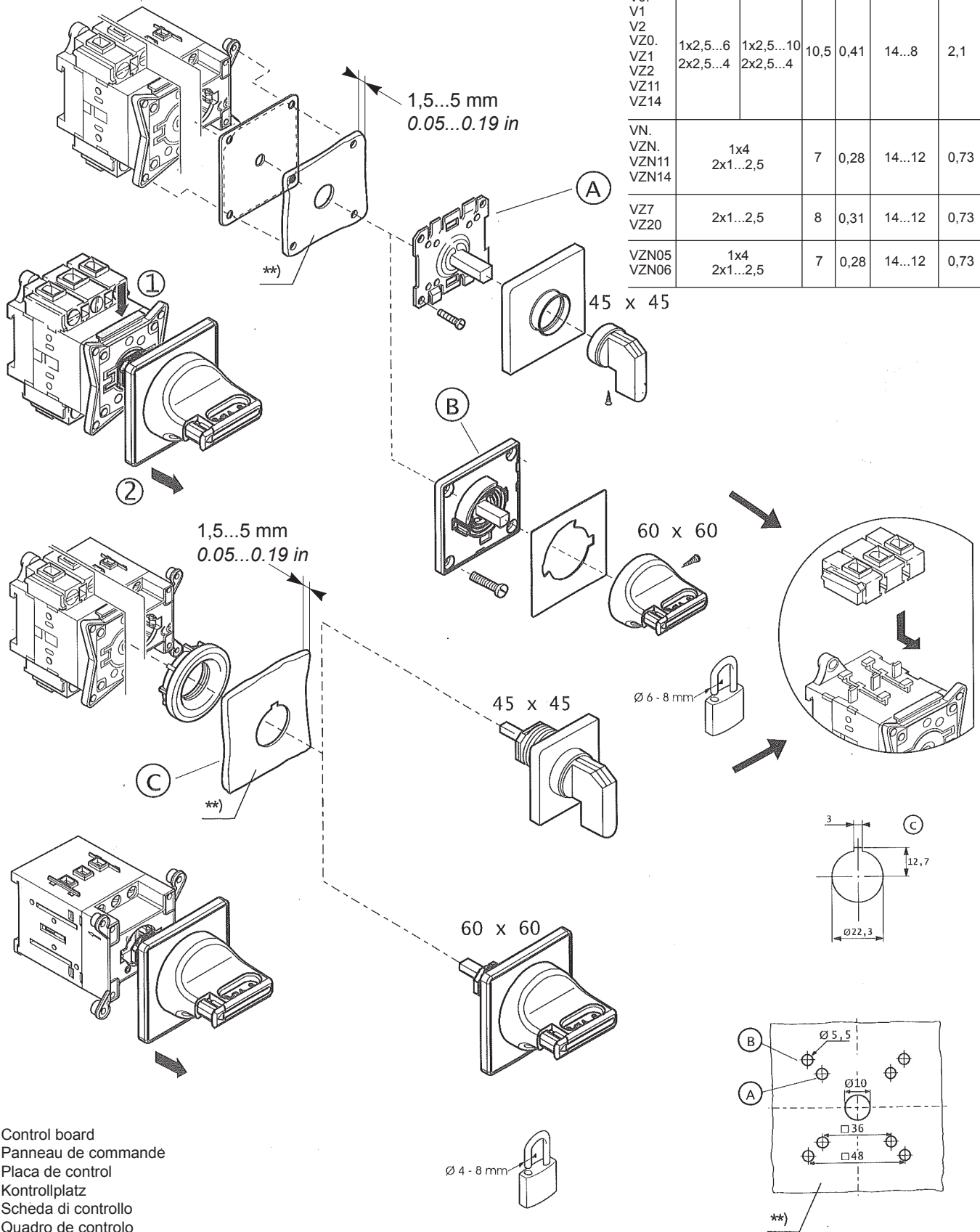

** Control board
 Panneau de commande
 Placa de control
 Kontrollplatz
 Scheda di controllo
 Quadro de controle
 控制板
 Приборный щит

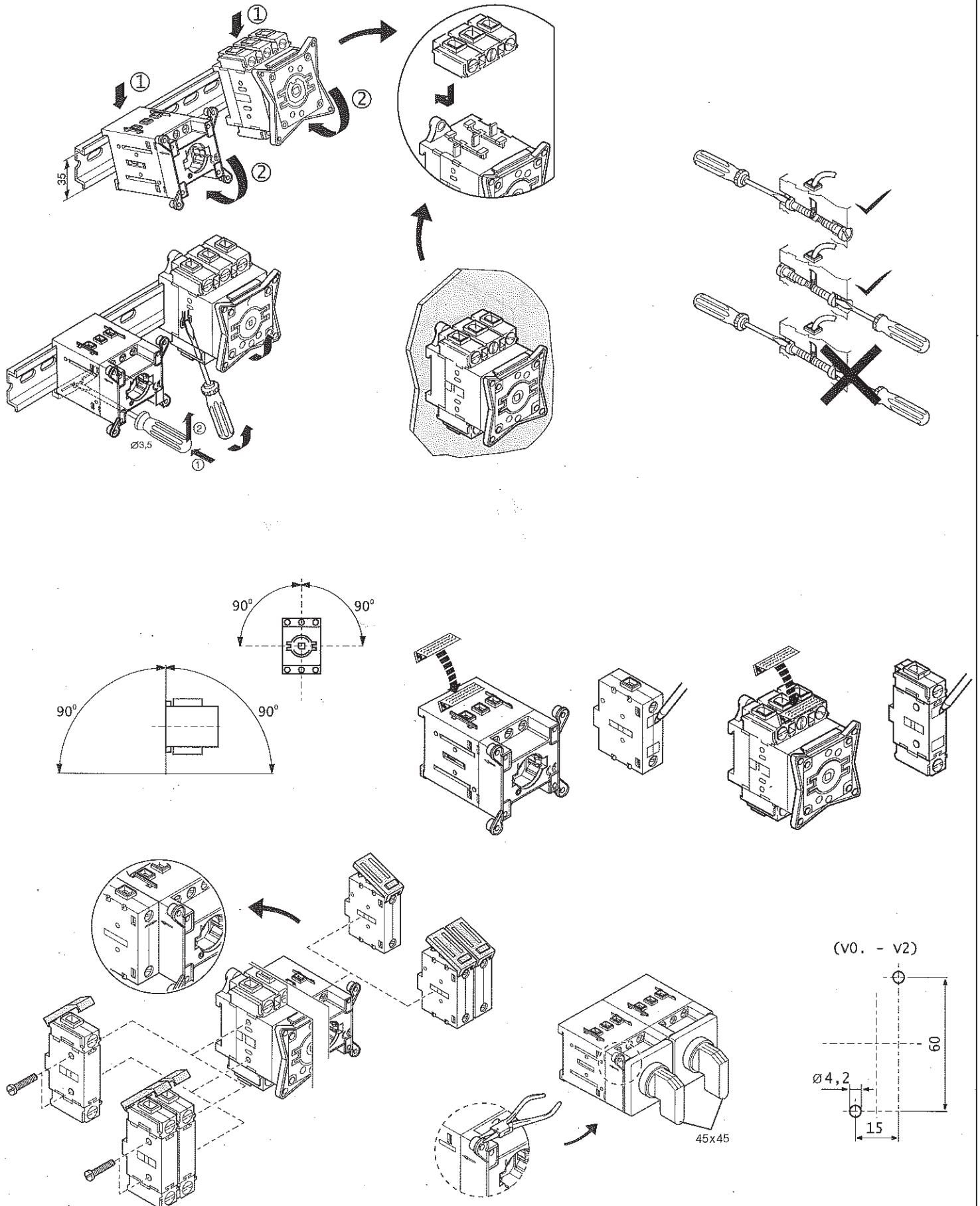

	mm ²		mm	in	AWG (60/75°C)	N.m	lb-in.
V3 V4					10*	4	35
VZ3 VZ4	1x4...16 2x4...10	1x4...25 2x4...10	15,5	0,61	8	4,5	40
VZ12 VZ15					2	5,6	50
VZ7 VZ20	2x1...2,5		8,0	0,31	14...12	0,8	7

* Use solid wire only / Utilisez uniquement du câble rigide
 Utilice cable sencillo solamente / Nur solidee Leiter verwenden
 Usare solo fili rigidi / Utilizar apenas o fio sólido
 仅限使用实芯电线 / Используйте только одножильный провод большого сечения

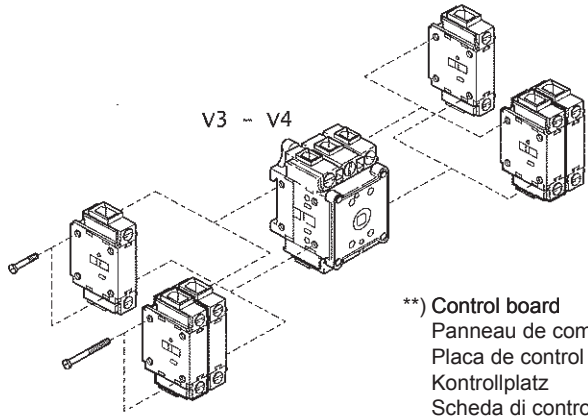
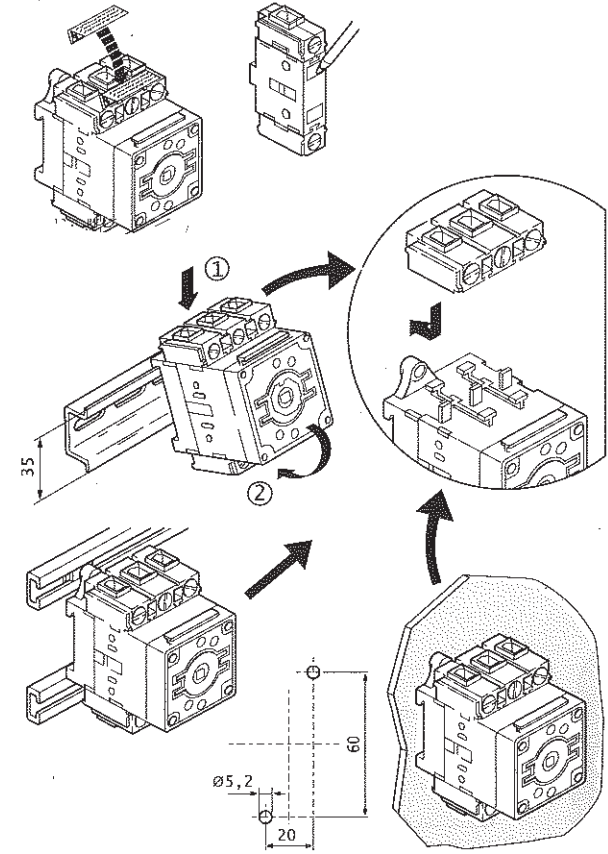
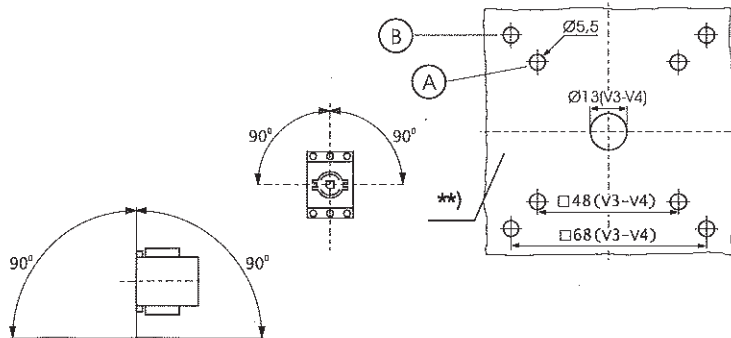
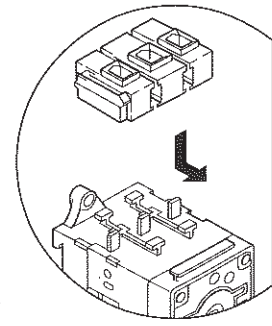
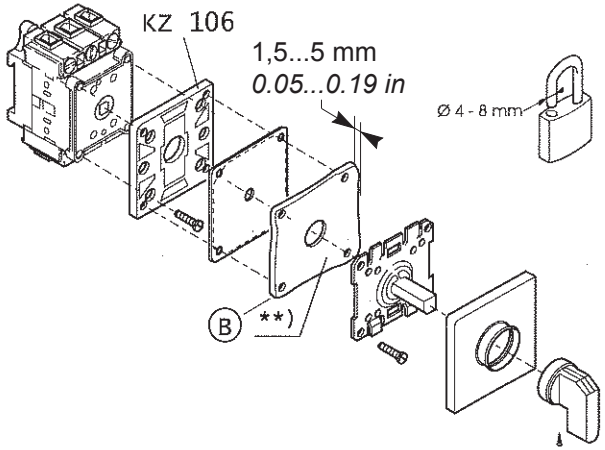
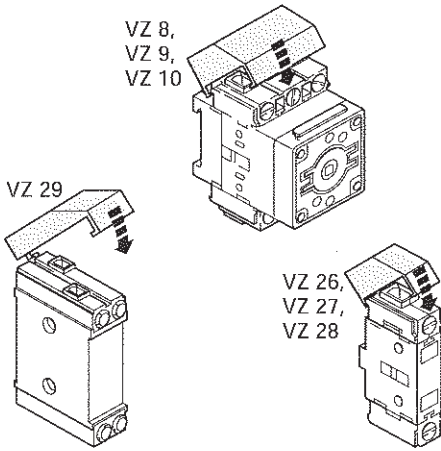
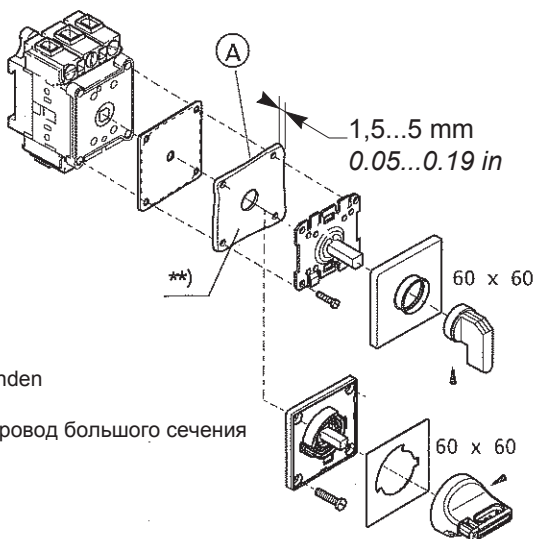

** Control board
 Panneau de commande
 Placa de control
 Kontrollplatz
 Scheda di controllo
 Quadro de controlo
 控制板
 Приборный щит

	mm ²		mm		in	AWG (60/75°C)	N.m	lb-in.
V5	1x10...70,	1x10...95,	21	0,83	8...2	22,6	200	
V6	2x10...35,	2x10...35,						
VZ13	1x25+1x50	1x25+1x50						
VZ16			15,5	0,61				
VZ15								
VZ7	2x1...2,5		8	0,31	14...12	0,8	7	
VZ20								

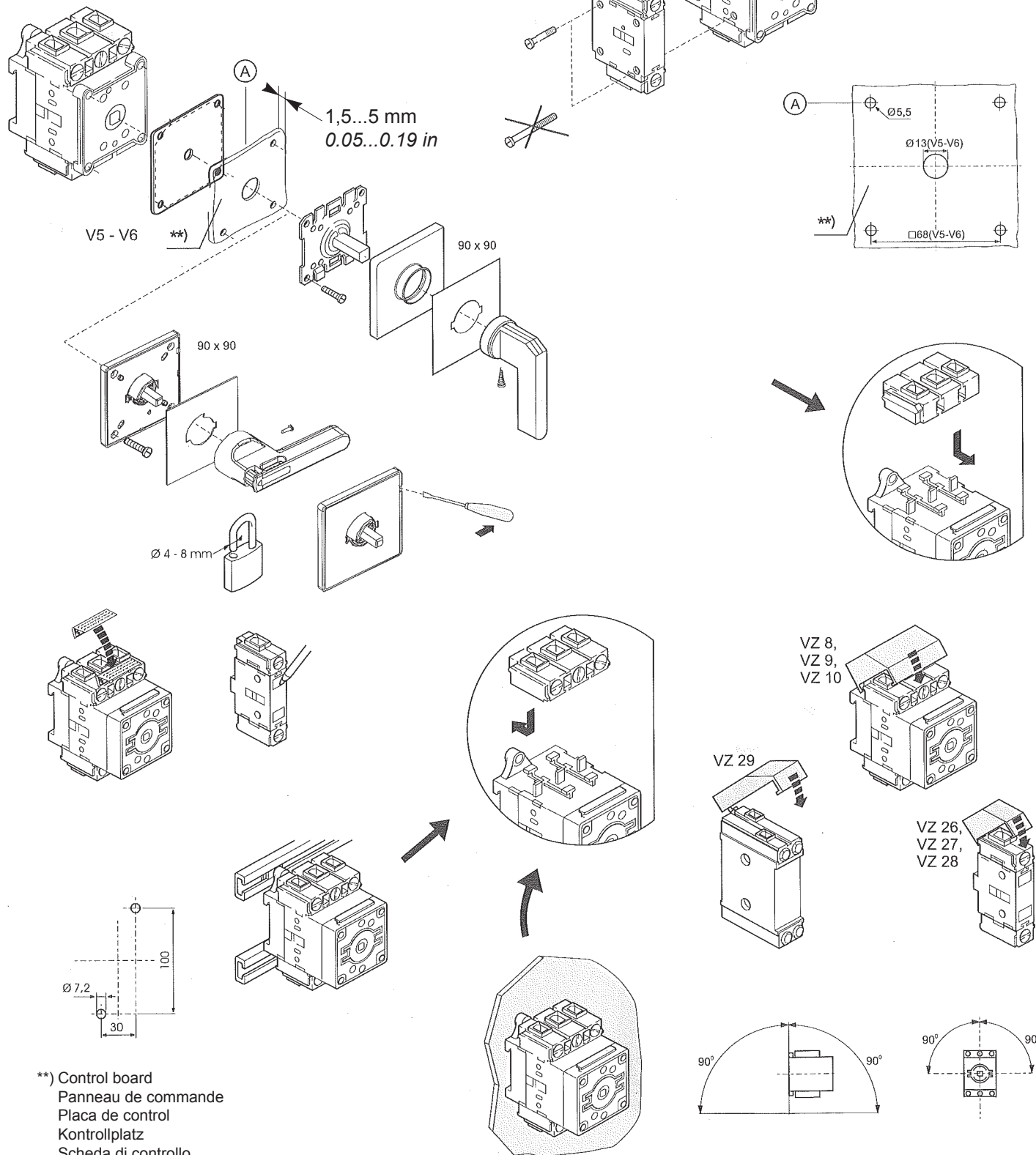

**) Control board
 Panneau de commande
 Placa de control
 Kontrollplatz
 Scheda di controllo
 Quadro de controle
 控制板
 Приборный щит

Schneider Electric Industries SAS

35, rue Joseph Monier
CS30323
92500 Rueil-Malmaison
France

<http://www.schneider-electric.com>

W9 1646005 0111 A06



Printed on recycled paper.

Уполномоченный поставщик в РФ:
АО «Шнейдер Электрик»
Адрес: 127018, г. Москва, ул.
Двинцев, д.12, корп.1,
тел. +7 (495)777 99 88,
факс: +7 (495)777 99 94, 8-800-200-6446
www.schneider-electric.ru

